

SWISHER

ZT2766KZ
27 HP - 66" CUT

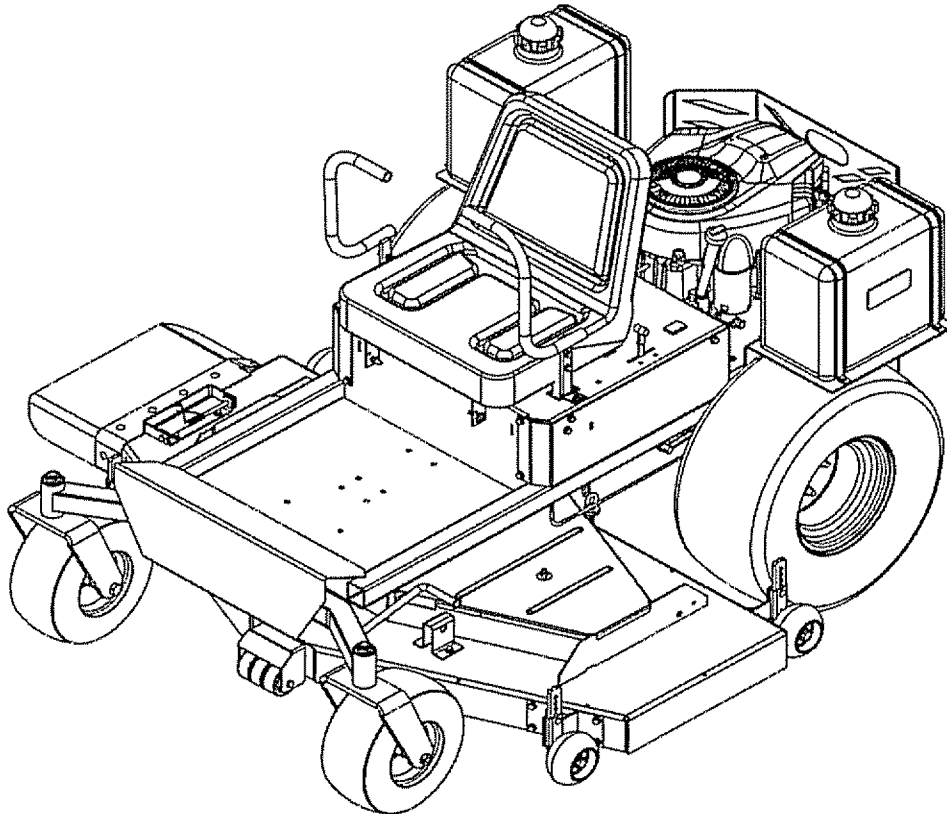

CELEBRATING OVER 60 YEARS OF INNOVATION

1945 - 2008

1602 CORPORATE DRIVE, P.O. BOX 67, WARRENSBURG, MISSOURI 64093
PHONE 660-747-8183 FAX 660-747-8650

Manufacturing quality lawn care equipment since 1945

Made In The

USA

14689
Rev. 08 - 221

OWNER'S MANUAL
STARTING SERIAL # L108-193001

LIMITED WARRANTY

The manufacturer's warranty to the original consumer purchaser is: This product is free from defects in materials and workmanship for a period of two (2) years from the date of purchase by the original consumer purchaser. We will repair or replace, at our discretion, parts found to be defective due to materials or workmanship. This warranty is subject to the following limitations and exclusions:

- 1) Engine Warranty All engines utilized on our products have a separate warranty extended to them by the individual engine manufacturer. Any engine service difficulty is the responsibility of the engine manufacturer and in no way is Swisher Mower Co., Inc. or its agents responsible for the engine warranty. The Briggs & Stratton Engine Service Hot-Line is 1-800-233-3723. The Tecumseh Engine Service Hot-Line is 1-800-558-5402.

- 2) Commercial Use **This product is not intended for commercial use and carries no commercial warranty.**

- 3) Limitation This warranty applies only to products which have been properly assembled, adjusted, and operated in accordance with the instructions contained within this manual. This warranty does not apply to any product of Swisher Mower Co., Inc., that has been subject to alteration, misuse, abuse, improper assembly or installation, shipping damage, or to normal wear of the product.

- 4) Exclusions Excluded from this warranty are normal wear, normal adjustments, normal maintenance, and battery*(see battery section.)

In the event you have a claim under this warranty, you must return the product to an authorized service dealer. All transportation charges, damage, or loss incurred during transportation of parts submitted for replacement or repair under this warranty shall be borne by the purchaser. Should you have any questions concerning this warranty, please contact us toll-free at 1-800-222-8183. The model number, serial number, date of purchase, and the name of the authorized Swisher dealer from whom you purchased the mower will be needed before any warranty claim can be processed.

THIS WARRANTY DOES NOT APPLY TO ANY INCIDENTAL OR CONSEQUENTIAL DAMAGES AND ANY IMPLIED WARRANTIES ARE LIMITED TO THE SAME TIME PERIODS STATED HEREIN FOR ALL EXPRESSED WARRANTIES. Some states do not allow the limitation of consequential damages or limitations on how long an implied warranty may last, so the above limitations or exclusions may not apply to you. This warranty gives you specific legal rights and you may have other rights, which vary from state-to-state. This is a limited warranty as defined by the Magnuson-Moss Act of 1975.

CONTENTS

LIMITED WARRANTY.....	2	OPERATION.....	13
INTRODUCTION.....	4	Features.....	13
General.....	4	Starting.....	16
Before Operating.....	4	Grass Height of Cut.....	16
Uncrating & Assembly.....	5	Controls.....	17
SYMBOLS & DECALS.....	6	SERVICE & ADJUSTMENTS	18
SAFETY INSTRUCTIONS.....	7	Adjusting Deck Height.....	18
General use and safety rules..	7	Deck Level.....	18
Children Safety.....	8	Parking Brakes.....	18
Slope Operation.....	8	Deck Belt Replacement.....	19
CUSTOMER		Hydro Belt Replacement.....	20
RESPONSIBILITY.....	10	Seat Adjustment.....	21
Operator Presence.....	10	WIRING SCHEMATIC.....	22
Tires.....	10	PARTS BREAKDOWN.....	23
Blade Maintenance.....	10	TROUBLESHOOTING.....	34
Battery.....	10	MOWER IDENTIFICATION... 	36
V-belts.....	11	REPLACEMENT PARTS.....	37
Engine.....	11	Warranty Rights.....	38
Overall Unit Care.....	11	SWISHER HISTORY.....	39
Transporting Safety.....	11		
SPECIFICATIONS.....	11		
Maintenance.....	12		

INTRODUCTION

Congratulations

Thank you for purchasing a Swisher Zero Turn mower. This machine is built for the greatest efficiency and rapid mowing of large areas. Conveniently located controls and dual commercial grade hydrostatic transmissions regulated by steering levers, contribute to the machine's performance.

This manual is a valuable document. Following the instructions for use, service, maintenance, etc. can greatly increase the life-span of your machine .

General

In this operator's manual, left and right, backward and forward are used in relation to the normal operators position.

Read Before Operating

NOTE:

If you have never used a Zero Turn mower before, refer to the Operation Controls section of this manual before attempting to operate one for the first time.

This machine is constructed only for mowing grass on lawns and other free and even ground without obstacles. This machine is not intended for commercial use. The manufacturer's directions concerning operation, maintenance, and repairs must be carefully followed.

This machine must only be operated, maintained, and repaired by persons that are familiar with the machine's special characteristics and who are well versed in safety instructions.

Accident prevention regulations, other general safety regulations, occupational safety rules, and traffic regulations must be followed without fail.

Unauthorized modifications to the design of the machine may absolve the manufacturer from liability for any resulting personal injury or property damage.

- Read engine manufacturer's operating and maintenance instructions.
- Read and observe all safety instructions on your mower and in the manual.
- Check engine oil.
- Check fuel caps to sure that they are in place.
- Know how to set the parking brake.
- Be sure mower blades are turned off – PTO switch pushed down.
- Know how to stop the engine – Turn key to off
- Know how to stop the unit – Return control handles to neutral

INTRODUCTION

Uncrating & Assembly

TOOLS REQUIRED:

- ✓ 2 - ½" Wrenches or ½" Socket with drive ratchet
- ✓ Tire pressure gauge
- ✓ Nail bar or claw hammer
- ✓ Wire snips

To Remove The Mower From The Crate:

- Dispose of top and side panels of the crate.
- Remove loose parts and packing material.
- Cut any banding or strapping that may be holding the mower to the crate.
- Disengage spark plug wire and place where it cannot make a connection.
- Raise the mower deck to its highest position.
- Install steering levers. Remove the bolts from the control arms on the mower. Align the holes in the lever with the holes in the control arms and attach with the bolts provided. **Make sure both bolts on both handles are tight.**
- Disengage the parking brake by pushing the handles to their fully extended position.
- Open the transmission valves at the rear of the unit by pulling the release rods and locking them in place. **SEE INSTRUCTION DECAL AT THE REAR OF THE UNIT.**
- Carefully push the mower off the crate to a safe and level area.
- Check engine oil. All engines are filled with oil and tested at the factory. Verify oil level and add if necessary before starting engine. **SEE ENGINE OWNER'S MANUAL**
- Check the battery. If the battery is put into service after the "month & year" of the date on the battery, then it may need to be charged with a 12 volt charger for a minimum of 1 hour, but no more than 2 hours at a rate of 6 to 10 amps.
- Attach battery cables to battery. **Always attach the positive terminal first.**
- Close the transmission valves at the rear of the unit. **SEE INSTRUCTION DECAL AT THE REAR OF THE UNIT.**
- Reconnect spark plug wire.
- Check tire pressure on all four wheels. **REFER TO UNIT SPECIFICATIONS TABLE**

SYMBOLS & DECALS

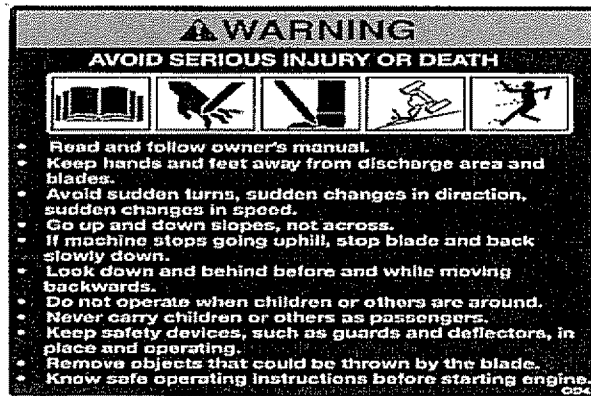

OD45- Warning Decal



Swisher Flag U.S.A. – OD39



Notice Do Not Alter Wiring Decal– OD74

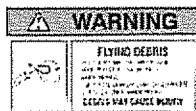

Flying Debris Decal – OD43



Operator Must Be Seated Decal– OD73



Triangle Danger Decal – OD55



No Step Decal – OD11

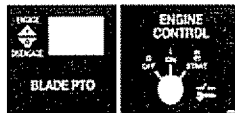

Key/PTO Decal - 10273

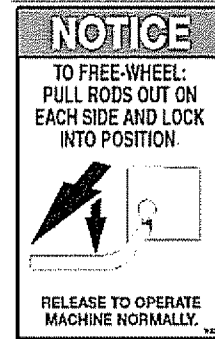

Hydro Release - 10280

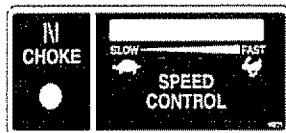

Throttle/Choke Decal - 10271



Danger/Warning Decal - 10276

SAFETY INSTRUCTIONS

These instructions are for your safety. Read them carefully.



This Safety Alert Symbol indicates important messages in this manual. When you see this symbol, carefully read the message that follows and be alert to the possibility of personal injury.

General Use

- Read all instructions in this operator's manual and on the machine before starting it. Ensure that you understand them and then abide by them.
- Learn how to use the machine and its controls safely and learn how to stop quickly. Also learn to recognize the safety decals.
- Only allow the machine to be used by adults who are familiar with its use.
- Make sure nobody else is in the area of the machine when you start the engine, engage the drive, or run the machine.
- Stop the machine if someone enters the work area.
- Clear the area of objects such as stones, toys, steel wire, etc. that may become caught in the blades and thrown out.
- **Do Not Use this machine without the Discharge Chute in place.**
- Stop the engine and disconnect the spark plug before cleaning the discharge deck.
- Never take passengers. The machine is only intended for use by one person.
- Always look around before and during reversing maneuvers.
- Slow down before turning.
- Shut down the mower deck when not mowing.
- Be careful when rounding fixed objects, so that the blades do not hit them.
- Only operate the machine in daylight or other well-lit conditions.
- Keep the machine a safe distance from holes or other irregularities in the ground.
- Never use the machine if you are tired, if you have consumed alcohol, or if you are taking other drugs or medications that can affect your vision, judgment, or coordination.
- Beware of traffic when working near or crossing a road.
- Never leave the machine unsupervised with the engine running. Always shut down the blades, engage the parking brake, stop the engine, and remove the ignition key before leaving the machine.
- Never allow children or other persons not trained in the use of the machine to use or service it. Local laws may regulate the age of the user.
- Make sure that you have first aid equipment close at hand when using the machine.
- Never use the machine when barefoot. Always wear protective shoes or boots.

NOTE:

If you have never used a Zero Turn mower before, refer to the Operation Controls section of this manual before attempting to operate one for the first time.

SAFETY INSTRUCTIONS

General Use Continued...

- Always wear approved protective glasses or a full visor when assembling or driving.
- Ear Protection is recommended
- Never wear loose clothing that can get caught in moving parts.

Children

- Serious accidents may occur if you fail to be on guard for children in the area of the machine. Children are often attracted to the machine and mowing work. Never assume that children will stay put where you last saw them.
- Keep children away from the mowing area and under close supervision by another adult.
- Shut off the machine if children enter the work area.
- Never allow a child to ride with you.
- Never allow children to operate the machine.
- Be extra cautious near corners, bushes, trees, or other objects that block your view.

Slope Operation

- Remove obstacles such as stones, tree branches, etc.
- Mow up and down, not side to side. Never drive the rider on terrain that slopes more than 10 degrees.
- Avoid starting or stopping on a slope. If the tires begin to slip, shut down the blades and drive slowly down the slope.
- Always drive evenly and slowly on slopes.
- Make no sudden changes in speed or direction.
- Avoid unnecessary turns on slopes, and if it proves necessary, turn slowly and gradually downward, if possible.
- Watch for holes, ruts, or bumps. On uneven terrain, the machine can tip more easily. Long grass can hide obstacles.
- Drive slowly and use small movements of the steering controls.
- Do not mow wet grass. It is slippery, and the tires can lose their grip, so that the machine slides.
- Do not try to stabilize the machine by putting a foot on the ground.

Remember

The operator is responsible for avoiding dangers or accidents.



WARNING

When using the machine, approved personal protective equipment shall be used. Personal protective equipment cannot eliminate the risk of injury, but it will reduce the degree of injury if an accident does occur. Ask your retailer for help in choosing the right equipment.



Remember

The operator is responsible for avoiding dangers or accidents.

MOWING SAFETY

- **WARNING** – Petrol is highly flammable.
 - store fuel in containers specifically designed for this purpose;
 - refuel outdoors only and do not smoke while refueling;
 - add fuel before starting the engine. Never remove the cap of the fuel tank or add petrol while the engine is running or when the engine is hot.
 - if petrol is spilled, do not attempt to start the engine but move the machine away from the area of spillage and avoid creating any source of ignition until petrol vapors have dissipated;
 - replace all fuel tanks and container caps securely.
- Replace faulty silencers;
- before using, always visually inspect to see that the blades, blade bolts and cutter assembly are not worn or damaged. Replace worn or damaged blades and bolts in sets to preserve balance;
- on multi-bladed machines, take care as rotating one blade can cause other blades to rotate.

MAINTENANCE AND STORAGE

- Keep all nuts, bolts and screws tight to be sure the equipment is in safe working condition;
- never store the equipment with petrol in the tank inside a building where fumes can reach an open flame or spark;
- allow the engine to cool before storing in any enclosure;
- to reduce the fire hazard, keep the engine, silencer, battery compartment and petrol storage area free of grass, leaves, or excessive grease;
- check the grass catcher frequently for wear or deterioration;
- replace worn or damaged parts for safety;
- if the fuel tank has to be drained, this should be done outdoors.
- when machine is to be parked, stored or left unattended, lower the cutting means unless a positive mechanical lock is used.

TRAINING

All drivers should seek and obtain professional and practical instruction. Such instruction should emphasize:

- the need for care and concentration when working with ride-on machines;
- control of a ride-on machine sliding on a slope will not be regained by the application of the brake. The main reason for loss of control are:
 - i) insufficient wheel grip;
 - ii) being driven too fast;
 - iii) inadequate braking;
 - iv) the type of machine is unsuitable for its task;
 - v) lack of awareness of the effect of ground conditions, especially slopes;
 - vi) incorrect hitching and load distribution.

OPERATION

- Do not operate the engine in a confined space where dangerous carbon monoxide fumes can collect;
- when using any attachments, never direct discharge of material toward bystanders nor allow anyone near the machine while in operation;
- never operate the machine with defective guards, or without safety protective devices in place;
- do not change the engine governor settings or over speed the engine. Operating the engine at excessive speed can increase the hazard of personal injury;
- disengage drive to attachments, stop the engine, and disconnect the spark plug wire(s) or remove the ignition key:
 - before clearing blockages or unclogging chute;
 - before checking, clearing or working on the machine;
 - after striking a foreign object. Inspect the machine for damage and make repairs before restarting and operating the equipment;
 - if the machine starts to vibrate abnormally (check immediately);
- stop the engine and disengage drive to attachment:
 - before refueling;
 - before removing the grass catcher;
 - before making height adjustment unless adjustment can be made from the operator's position

CUSTOMER RESPONSIBILITIES

Operator Presence System

Be sure the operator presence and interlock systems are working properly. If your mower does not function as described, repair the problem immediately.

- The engine should not start unless the parking brake is engaged and the PTO (Blade Engagement – See OPERATION FEATURES section of this manual) switch is disengaged (pressed down).
- When the engine is running, the operator should never leave the seat without first setting the parking brake and shutting off the engine.
- When the engine is running and the PTO switch is engaged, any attempt by the operator to leave the seat without first disengaging the PTO switch, should shut off the engine.
- When the engine is running and the control levers are rotated in, the operator should never attempt to leave the seat without rotating the control levers out, shutting off the engine and engaging the parking brake.
- The PTO switch should never engage without the operator on the seat.

Tires

- Maintain proper air pressure in all tires (SEE SPECIFICATIONS section)
- Keep tires free of gasoline, oil, or insect control chemicals which can harm rubber.
- Avoid stumps, stones, deep ruts, sharp objects and other hazards that may cause tire damage.

Blade Maintenance



CAUTION

Stop engine and remove ignition key for safety. Disconnect spark plug wire. Wear heavy, thick gloves when holding onto blade. Avoid the sharp edge of the blade.

For best results, mower blades must be kept sharp. Replace bent or damage blades.

- Safely raise front of mower. SEE WARNING
- Hold or block blade from turning.
- Loosen blade nut and remove blade.
- Replace blade, (SEE SPECIFICATIONS).



WARNING

When it is necessary to raise the mower for any repair or service, use jackstands to provide adequate support. DO NOT rely on hydraulic or mechanical jacks

Battery

To clean battery and terminals

- Remove terminal guard.
- Disconnect the BLACK battery cable first, then the RED battery cable and remove the battery.
- Rinse the battery with plain water and dry.
- Clean terminals and battery cable ends with wire brush until shiny.
- Coat terminals with grease or petroleum jelly
- Reinstall battery
- Reconnect the battery cables



WARNING

The battery contains sulfuric acid and electrolytes which are poisonous and corrosive.

CHARGING TIPS

- To avoid a battery explosion, never attempt to charge a frozen battery.
- Warning:** Gel and AGM (Absorbed Glass Mat) batteries require a voltage-limited charger. Charging a Gel or AGM battery on a typical shop charger, even one time, may greatly shorten its life.
- Important:** Never overcharge batteries. Excessive charging will shorten battery life.
- Prior to charging, read the manufacturer's instructions for proper charger hook-up and use.
- Turn off charger prior to hook-up to avoid dangerous sparks. **PROTECT YOUR EYES!**
- Warning:** If the electrolyte is accessible, verify that plates are covered before beginning to charge. At the end of charge, add distilled water as needed to bring levels to the proper height. If water is added, charge for an additional 30 minutes to mix. If electrolyte levels are low but battery is not accessible, remove battery from service.

•The maximum charge rate in amperes should be no more than 1/3 of the battery's reserve capacity minute rating. If the terminal voltage exceeds 16.0 volts while charging, reduce the charge rate.

•Continue charging and reduce the rate as needed until a 2 hour period results in no increase in voltage or decrease in current.

If violent gassing or spewing of electrolyte occurs, or the battery case feels hot to the touch, temporarily reduce or halt charging.

VOLTAGE		STATE OF CHARGE	APPROX. BATTERY CHARGING TIME * TO FULL CHARGE AT 80°F/27°C			
STANDARD BATTERY			MAXIMUM RATE AT			
6 V	12 V		50 AMPS	30 AMPS	20 AMPS	10 AMPS
6.3	12.6	100%	FULL CHARGE			
6.2	12.4	75%	20 MIN.	35 MIN.	48 MIN.	90 MIN.
6.1	12.2	50%	45 MIN.	75 MIN.	95 MIN.	180 MIN.
6	12	25%	65 MIN.	115 MIN.	145 MIN.	280 MIN.
5.9	11.8	0%	85 MIN.	150 MIN.	195 MIN.	370 MIN.

* Test wet batteries every 4-6 months and recharge if necessary. Always test and charge if necessary before installation.

CUSTOMER RESPONSIBILITIES/SPECIFICATIONS

V-Belts

Check V-belts for deterioration and wear after 100 hours of operation and replace if necessary. Replace belts if they begin to slip from wear. SEE SPECIFICATION for belt part numbers and SERVICE section of this manual for instructions on how to replace the belt.

Engine

REFER TO YOUR ENGINE OWNERS MANUAL

Overall Unit Care

➤ Reduce the risk of fire by removing grass, leaves, and other debris that may have accumulated on the machine. Allow the machine time to cool before cleaning or putting it in storage.

➤ Wash mower periodically. Clean above and below deck.

➤ Keep all electrical connections clean and tight.

Driving and Transport on Public Roads

➤ Check applicable road traffic regulations before driving and transporting on public roads.

➤ If the machine is transported, you should always use approved fastening equipment and ensure that the machine is well anchored.

➤ The cutting deck should also be lowered to the lowest position and the parking brake engaged.

SPECIFICATIONS

GASOLINE CAPACITY AND TYPE	DUAL 5.0 GAL TANKS UNLEADED REGULAR
OIL TYPE (SPI-SF-SJ):	SEE ENGINE MANUAL
SPARK PLUG	SEE ENGINE MANUAL
GROUND SPEED	0 – 8 mph
TIRE SIZE	FRONT: 13 x 6.5 x 6 REAR: 23 x 10.5 x 12
TIRE PRESSURE	FRONT: 28 psi Max REAR: 20 psi Max
BATTERY	12V / Heavy Duty 275 CCA Type U1L
HYDRO Bolt Torque	27 + - 3 ft. lbs
BLADE BOLT TORQUE	35 ft. lbs
CUTTING HEIGHT	1.5" – 5"
CUTTING WIDTH	66" – 3 Mulching Blade System
PARKING BRAKE	Spring Assisted
FRONT AXLE	Pivoting
SEAT	15" Back w/ Arm Rest 6" Adjustable Slide Air Ride Suspension With Lumbar Support.
TRANSMISSION	Commercial Grade Eaton Hydrostatic
DECK LIFT	Electric Actuator
UNIT MEASUREMENTS	LENGTH: 70" WIDTH: 66 1/4 " Including Deck WEIGHT: 950 lbs

CUSTOMER RESPONSIBILITIES

MAINTENANCE SCHEDULE

	Before Each Use	8 Hours	25 Hours	50 Hours	100 Hours	Season	Before Storage
Check Brake Operation	X	X					
Check Tire Pressure	X	X					
Check Operator Presence	X						
Parking Brake	X						
Check for Loose Fasteners	X				X		X
Sharpen/Replace Mower Blades			X3				
Check Battery			X				X
Clean Battery & Terminals			X				X
Check Belts					X		
Check Engine Oil	X	X					
Change Engine Oil w/ filter				X1,2			
Change Engine Oil w/o filter			X1,2				
Replace Oil Filter					X1,2		
Clean Air Filter			X2				
Inspect Muffler				X			
Clean Engine Cooling Fins					X2		
Replace Spark Plug					X	X	
Replace Fuel Filter						X	

1 – Change more often when operating under a heavy load or in high ambient temperatures

2 – Service more often when operating in dirty or dusty conditions

3 – Replace blades more often when mowing in sandy soil

OPERATION

FEATURES

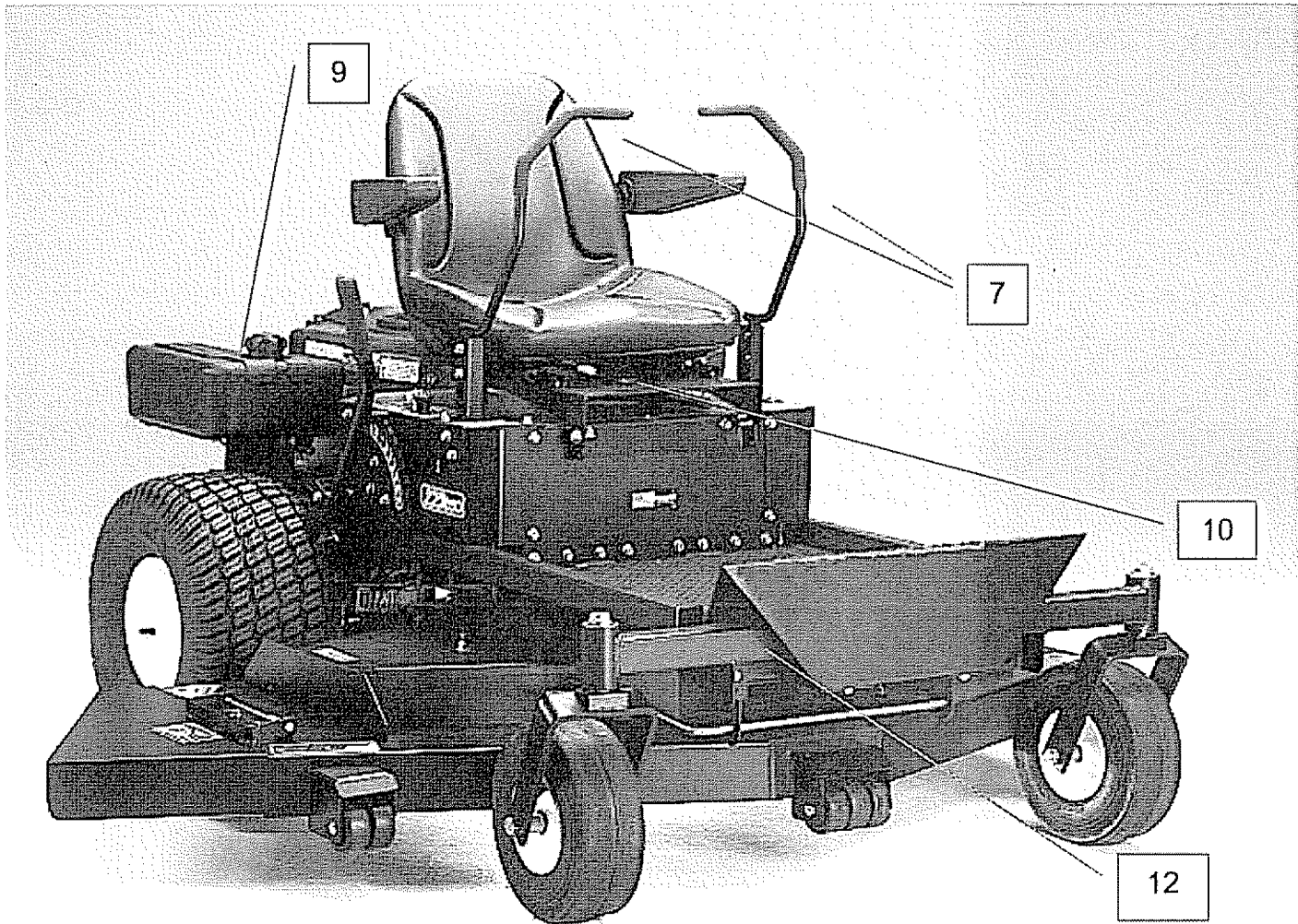

1. Throttle Control – Used to control Engine Speed
2. Hour Meter – Indicates hours of operation
3. Choke Control – Used when starting a cold engine
4. PTO Switch – Used to engage or disengage the deck blades
5. Ignition Switch – Used to start or stop the engine
7. Control Lever – Sets the speed of the mower in both the forward and reverse directions and also turns the mower.
8. Hydro Bypass – Engages transmissions for normal operation and disengages transmissions for pushing or pulling the unit
9. Fuel Tanks – Dual 5.0 gal fuel tanks
10. Seat Slide
11. Battery
12. Pivoting Front Axle
13. Discharge Chute

SEE DETAILS PAGE

OPERATION

FEATURES

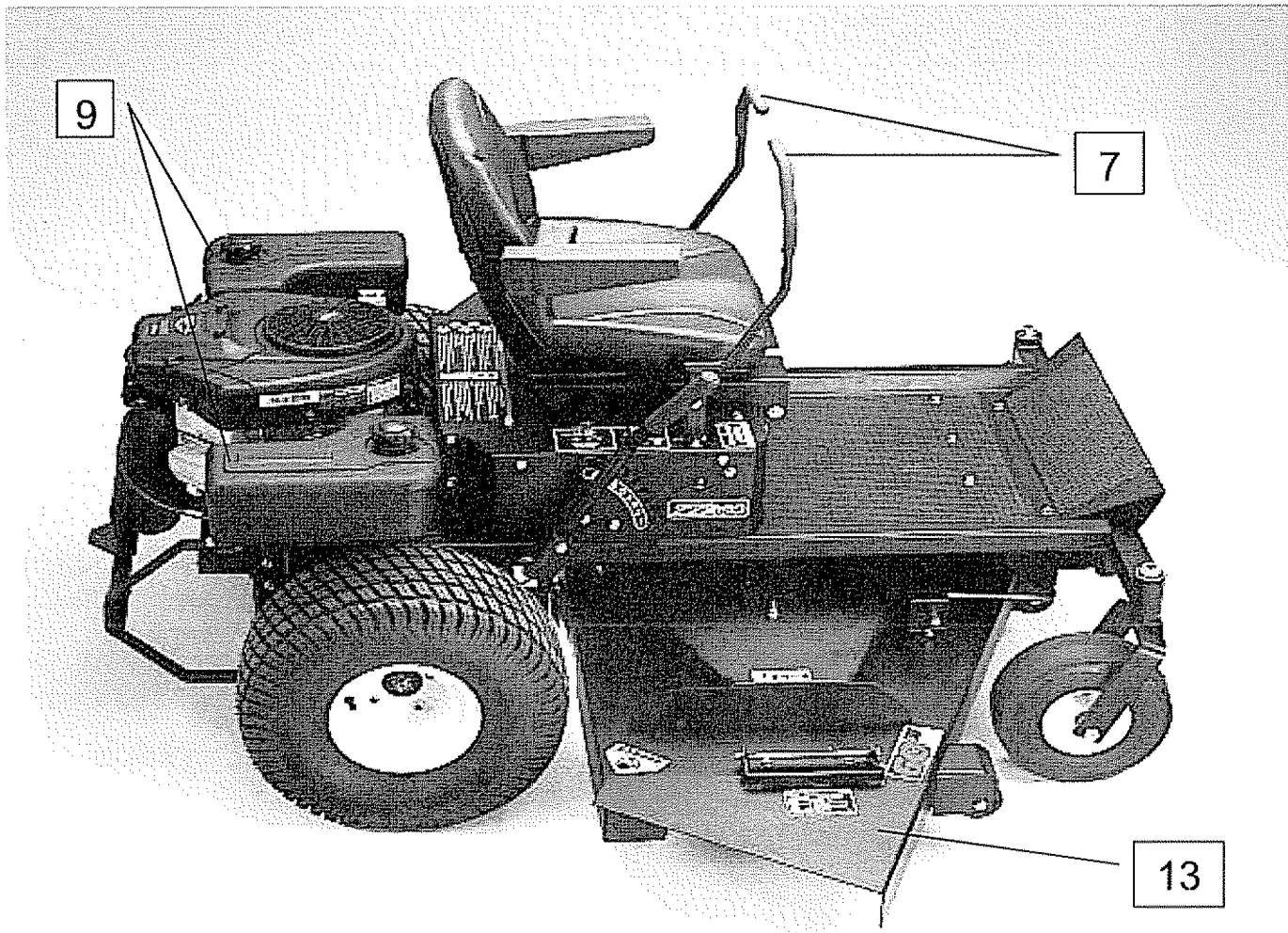

1. Throttle Control – Used to control Engine Speed
2. Hour Meter – Indicates hours of operation
3. Choke Control – Used when starting a cold engine
4. PTO Switch – Used to engage or disengage the deck blades
5. Ignition Switch – Used to start or stop the engine
7. Control Levers – Sets the speed of the mower in both the forward and reverse directions and also turns the mower .
8. Hydro Bypass – Engages transmissions for normal operation and disengages transmissions for pushing or pulling the unit
9. Fuel Tanks – Dual 5.0 gal fuel tanks
10. Seat Slide
11. Battery
12. Pivoting Front Axle
13. Discharge Chute

SEE DETAILS PAGE

OPERATION

FEATURES

Left Control Panel

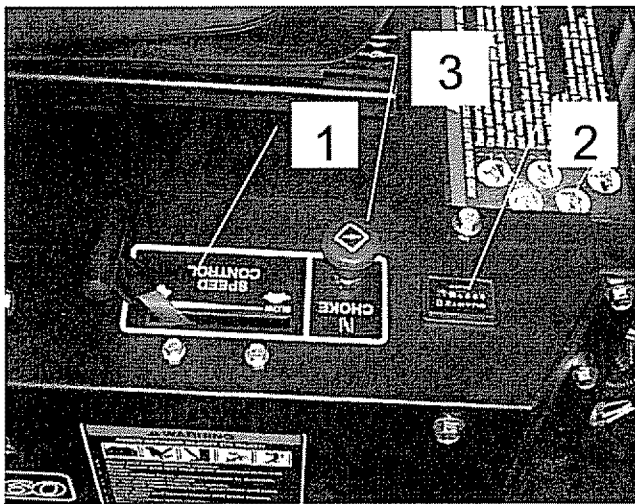

Right Control Panel

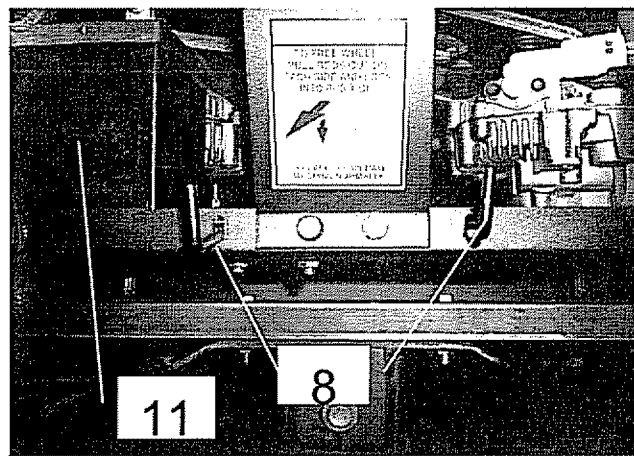
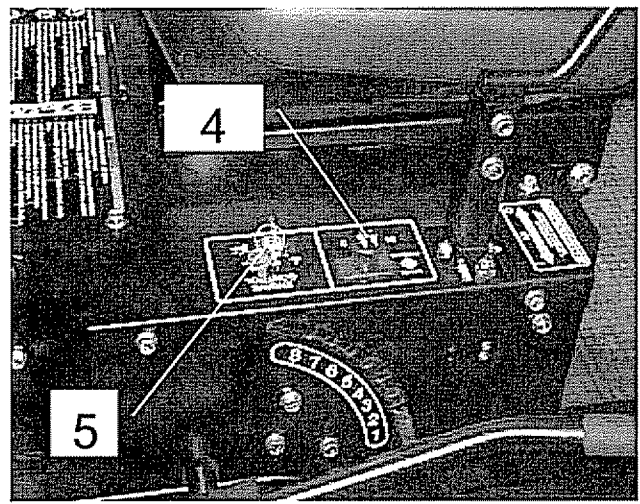

Rear of Unit

1. Throttle Control – Used to control Engine Speed
2. Hour Meter – Indicates hours of operation
3. Choke Control – Used when starting a cold engine
4. PTO Switch – Used to engage or disengage the deck blades
5. Ignition Switch – Used to start or stop the engine
6. Fuel Tanks – Dual 5.0 gal fuel tanks
7. Control Levers – Sets the speed of the mower in both the forward and reverse directions and also turns the mower.
8. Hydro Bypass – Engages transmissions for normal operation and disengages transmissions for pushing or pulling the unit
9. Fuel Tanks – Dual 5.0 gal fuel tanks
10. Seat Slide
11. Battery
12. Pivoting Front Axle
13. Discharge Chute

OPERATION

Starting

- Operator must be sitting in the seat. Control handles must be in the neutral (outward) position. PTO must be in the disengage position (pushed down).
- Set choke (if needed), turn key and release as soon as engine starts. Adjust throttle to half and shut choke off.
- Be sure all people are clear of the area. Set engine RPM to maximum and then engage blades.

NOTE:

If you have never used a Zero Turn mower before, refer to the Operation Controls section of this manual before attempting to operate one for the first time.

Grass Height & Cutting Suggestions

- Do not attempt to cut wet grass
- The average lawn should be cut to 2 ½" during the cool season and to over 3" during the hot months. For healthier and better looking lawns, mow often and after moderate growth.
- As a rule , never cut more than 1/3 of the total grass blade length. Correct mowing height can reduce weeds and lawn disease.
- For best performance, grass over 6 inches in height should be mowed twice. The first cut should be set relatively high and the second set to the desired height.

OPERATION

Controls

➤ Be familiar with all controls, their functions and how to operate them before starting the machine.

➤ Motion control levers on each side of the console control the direction of movement. SEE FIGURE BELOW

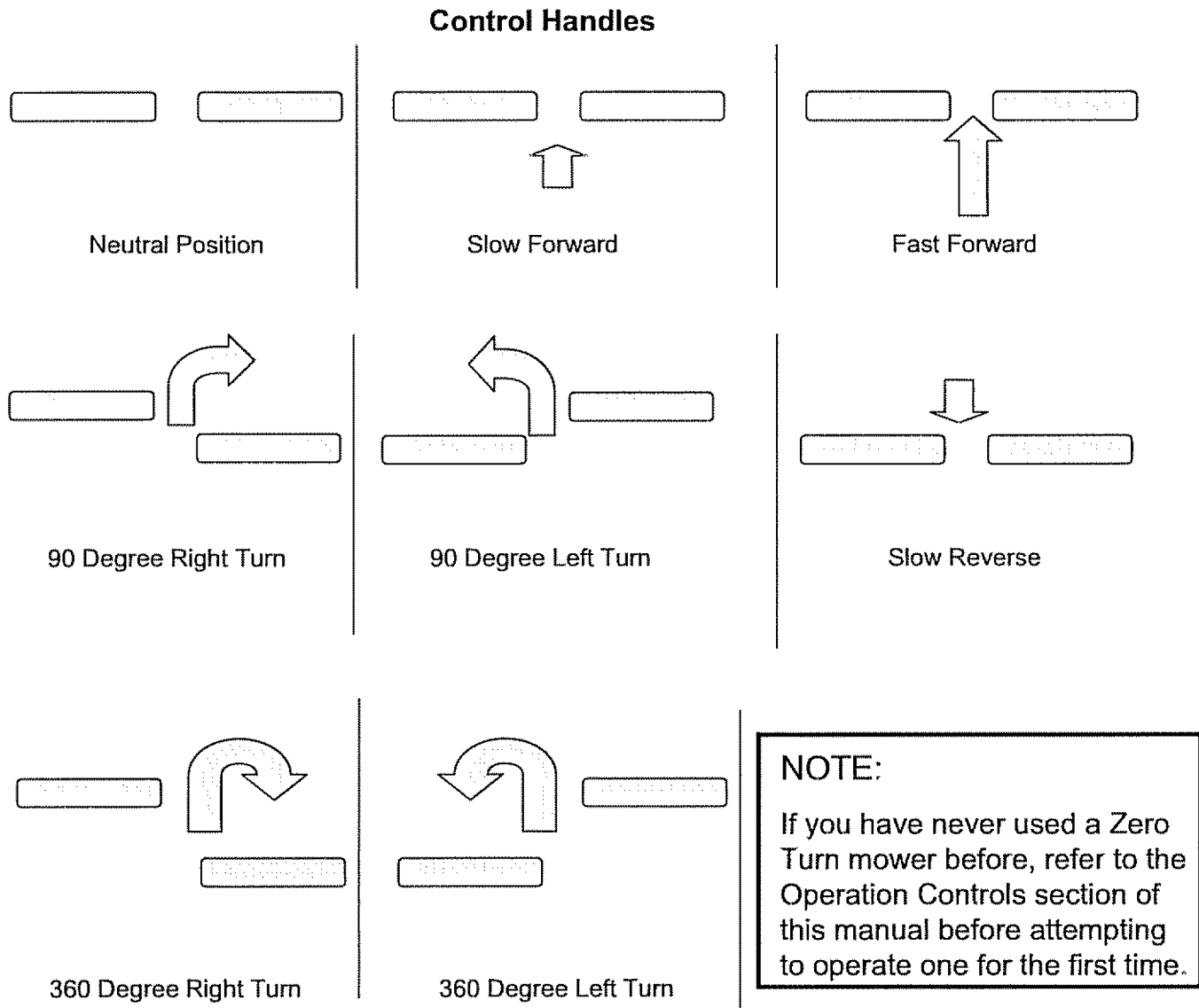

Note: The pressure required to operate the mower is very slight

SERVICE & ADJUSTMENTS

Adjusting The Cutting Height

- Use the actuator switch to raise or lower the deck to the desired position.
- Position 1 is the lowest setting and Position 8 is the highest position
- The cutting range is from approximately 1 ½" to approximately 5"

Deck Leveling

TOOLS REQUIRED:

- ✓ 2 - ½" Wrenches or ½" Socket with drive ratchet
- Lower the cutting deck down to the lowest position (position 1)
- Loosen the nuts on the top side of the deck hanger brackets (3 places) where the lift chains attach to.
- With all three loose on top of the brackets the deck should now set on the ground resting on the roller wheels.
- Tighten the nuts on the top of the lift brackets making sure that all three lift chains are pulled tight.
- Lift deck using the deck lift handle to the desired position

Parking Brakes

- ✓The Swisher ZT2766KZ is equipped with An Automatic Parking Brake system on each control handle.
- ✓When the control handles are in the out most position the parking brakes are on.
- ✓Adjustment for the system is located on the ends of the brake cable at the hydro pan & frame.
- ✓Raise the rear wheel off the ground
- ✓Disengage the hydro to be adjusted with the hydro release handle at the rear of the unit.
- ✓Adjust so that the brake is not on when the handles are in the operator position. The wheel should turn freely.
- ✓The wheel should not turn when the handle is moved to the engaged or outward position.
- ✓To tighten the brake, turn the adjustment nuts towards the end of the cable
- ✓Recheck adjustment with control handle
- ✓Lower unit back to the ground
- ✓Reengage the hydro at the rear of the unit



WARNING

When it is necessary to raise the mower for any repair or service, use jackstands to provide adequate support. DO NOT rely on hydraulic or mechanical jacks

SERVICE & ADJUSTMENTS

Deck Belt Routing & Replacement

Removal

- ✓ Disconnect spark plug wire
- ✓ Apply parking brake
- ✓ Lower the deck to its lowest position
- ✓ Remove the belt covers
- ✓ Disconnect tension idler
- ✓ Roll the belt over the top of the deck pulleys
- ✓ Remove belt

Replacement

- ✓ Install new belt by placing it around the deck pulleys. Refer to routing diagram below.
- ✓ The belt will be loose at this time
- ✓ Tightly secure the belt tension back to its original position
- ✓ Reinstall the belt covers
- ✓ Reconnect spark plug wire

Front of Unit

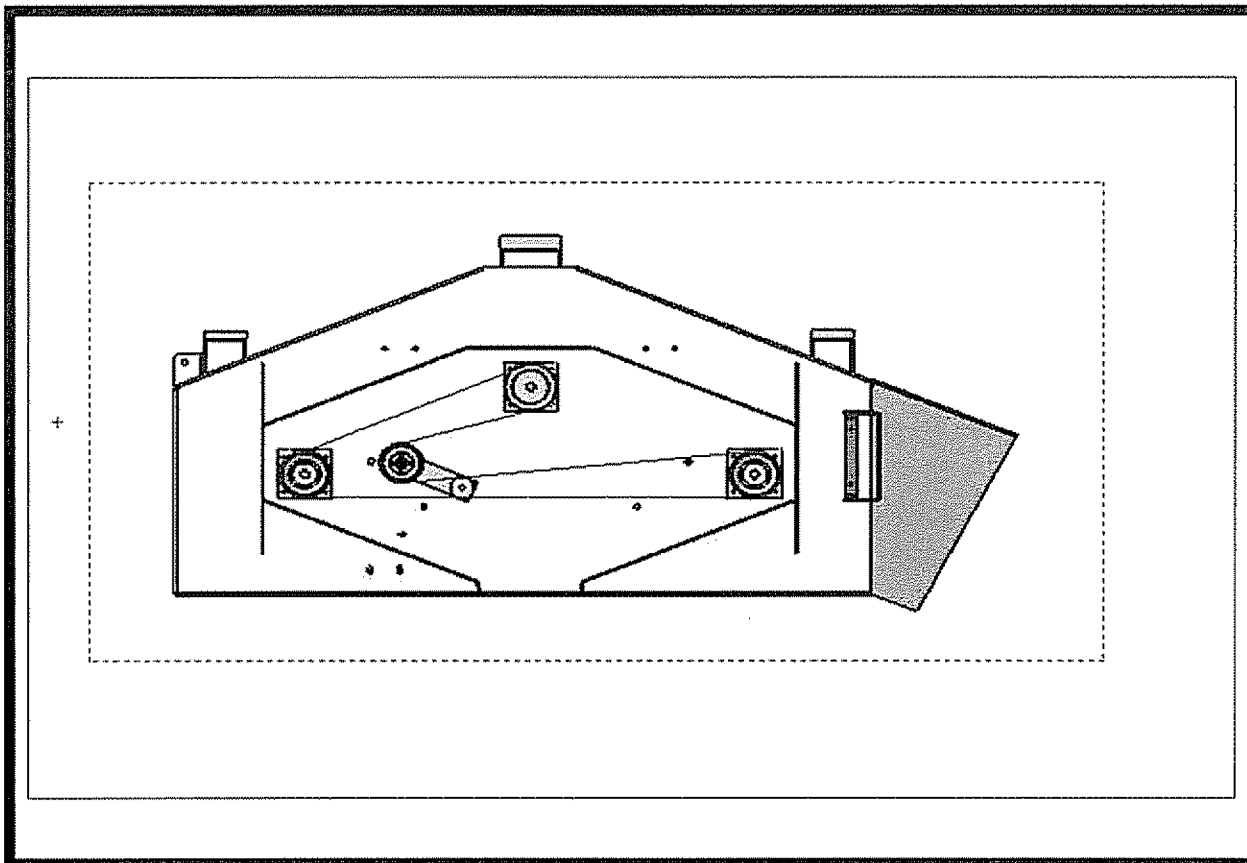

For replacement belt part number refer to Replacement Parts Quick Reference Chart in this manual

SERVICE & ADJUSTMENTS

Hydro Belt Routing & Replacement

Removal

- ✓ Disconnect spark plug wire
- ✓ Apply parking brake
- ✓ Disconnect wiring from electric clutch
- ✓ Remove clutch stop weldment (9973TK)
- ✓ Remove the engine to deck belt
- ✓ Disconnect idler spring
- ✓ Disconnect tension idler
- ✓ Remove belt from the engine pulley and from the Hydro pulleys

Replacement

- ✓ Install new belt by placing it around the engine pulley and the hydro pulleys. Refer to routing diagram below.
- ✓ The belt will be loose at this time
- ✓ Tightly secure the belt tension back to its original position
- ✓ Reinstall the belt from the engine to the deck
- ✓ Reconnect wiring to the electric clutch

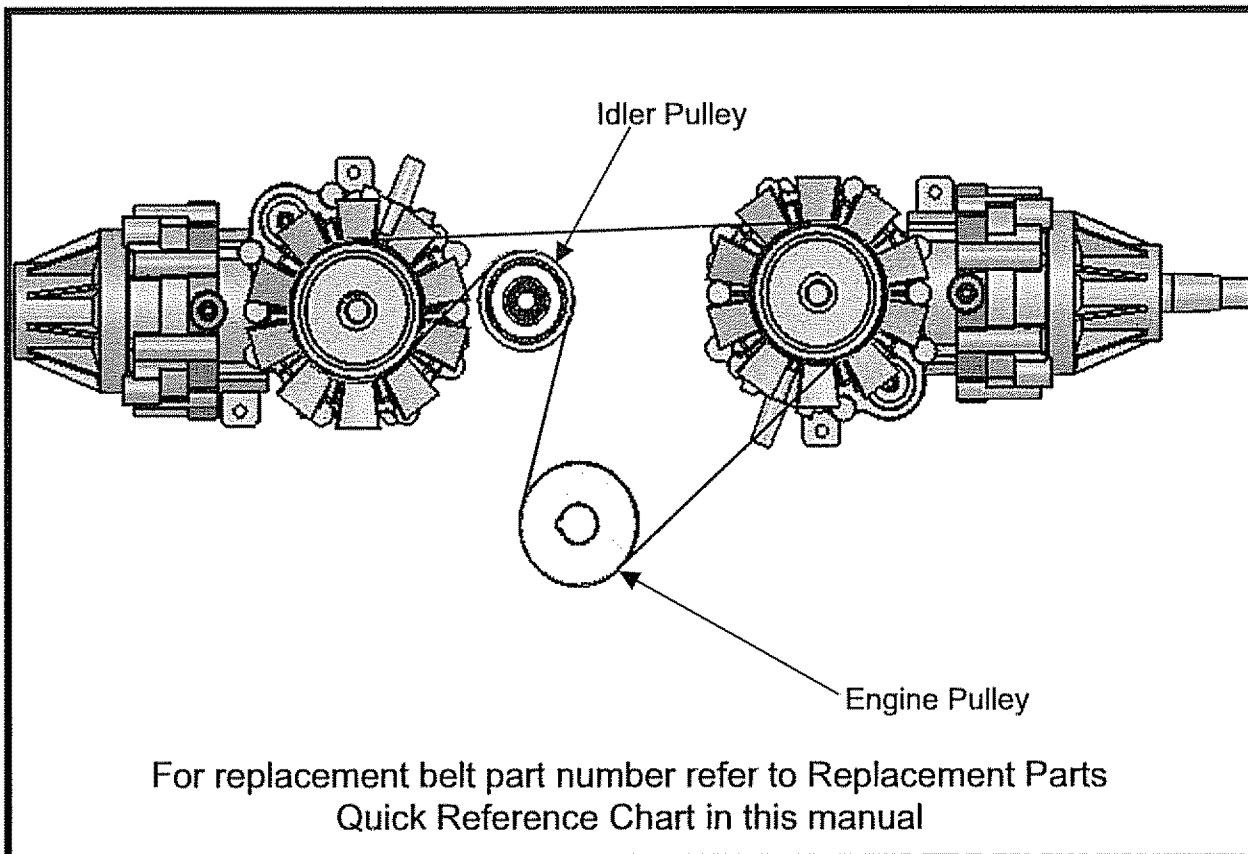

SERVICE & ADJUSTMENTS

Engine to Deck Belt

Removal

- ✓ Apply parking brake
- ✓ Lower the deck to its lowest position
- ✓ Disconnect tension idler
- ✓ Remove belt from the mower deck and the electric clutch

Replacement

- ✓ Install new belt by placing it around the electric clutch and route it through the idler and around the deck pulley. Refer to routing diagram below.
- ✓ The belt will be loose at this time
- ✓ Tightly secure the belt tension back to its original position

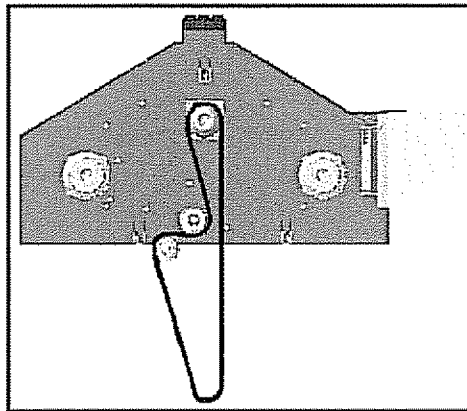

Seat Adjustment

- ✓ The Swisher ZT2766KZ is equipped with a 6" range sliding seat.
- ✓ Release the tension on the seat adjustment lever by pushing the yellow tip lever to the left. See features section in this manual
- ✓ Using your own weight, slide the seat to the desired position
- ✓ Release the lever
- ✓ Adjust knob on front of seat to desired position, for air suspension adjust lumbar support as desired.

Travel Reduction Adjustment

- ✓ To improve the tracking of the Swisher ZT2766KZ the speed of one of the rear wheels needs to be decreased. If the ZT2766KZ pulls to the right the left wheel will need to decrease speed and if pulling to the left the right wheel will need to decrease speed.
- ✓ To decrease the speed in one of the rear wheels turn the bolt counter clockwise. This will limit travel of the handle. Ensure after the bolt has been moved that the nuts holding the bolt in place are securely tightened.

ZT2766KP

WIRING HARNESS

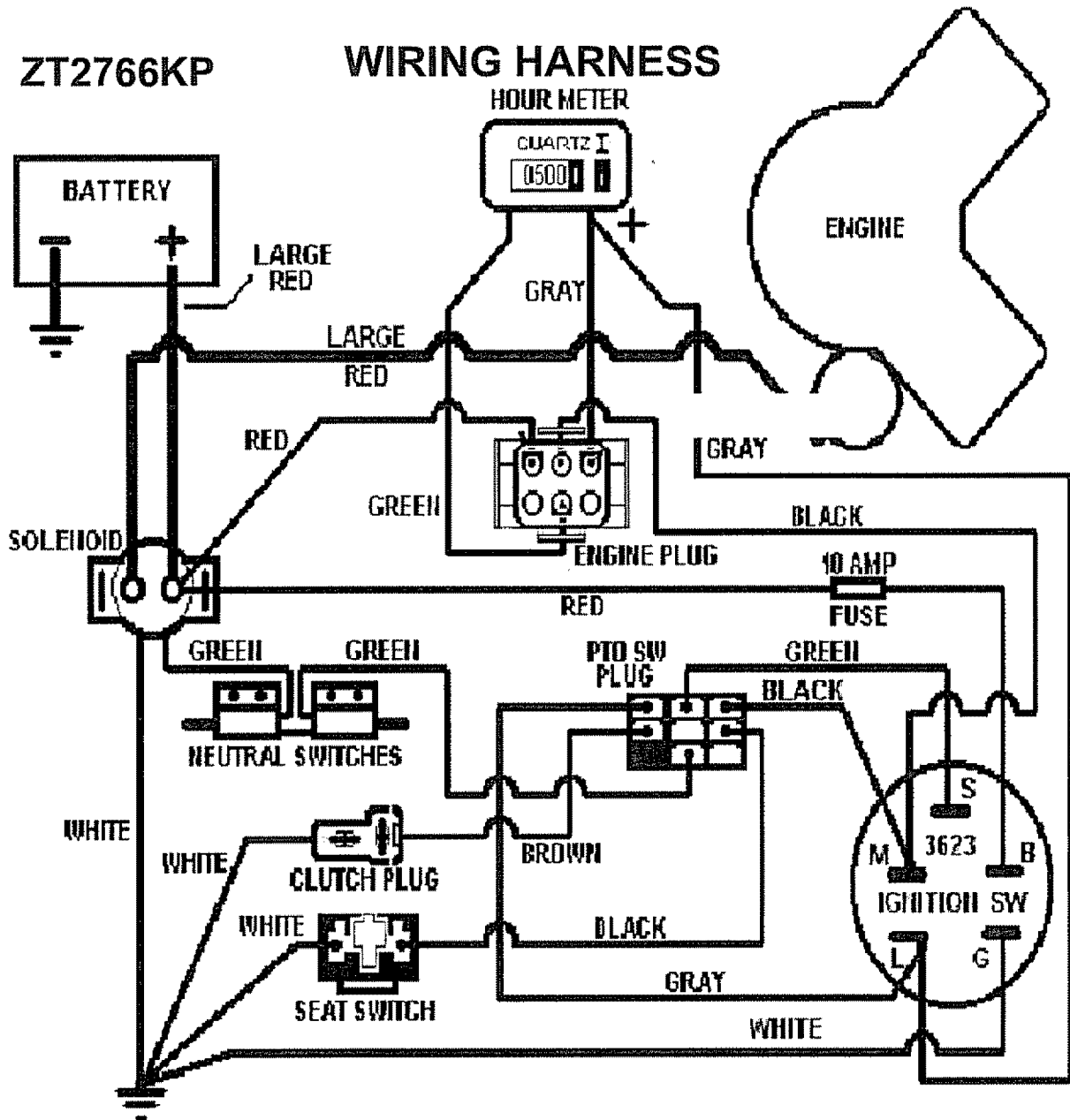

WARNING

When it is necessary to raise the mower for any repair or service, use jackstands to provide adequate support. DO NOT rely on hydraulic or mechanical jacks

PARTS BREAKDOWN

Item #	Description	Part #
1	Actuator - ZT Mow-zilla	14293
2	Height Indicator Bracket	11770
3	Indicator - Electric Lift; Mowzilla/Pro	14697
4	Bolt - 1/2-13 X 2 1/2 HCC GR5 ZY	NB510
5	1/2-13 Nyloc Nut	NB281
6	1/4-20 X 1 1/2 HCCGR2ZP	NB104Z
7	5/16-18 X 3/4 Serr Flng Bolt	NB596
8	5/16-18 Serrated Flng Nut ZY	NB170
9	Tilt Spring	2335
10	3/8-16 X 5 Turned Eyebolt ZY	10546
11	3/8-16 HNC GR2 ZP	NB212

Item #	Description	Part #
12	Lock Plate A/Turret	9922
13	Deck Lift Weldment	14682
14	Bolt - 5/16-18 X 1 1/2 HCC GR5 ZY	NB505
15	5/16 SAE Washer ZY	NB275
16	Latch Pin Bushing	7839Z
17	Chain - 9 Links, 3/16 Proof Coil Chain	14435
18	Nut, Nyloc 5/16-18 ZY	NB181

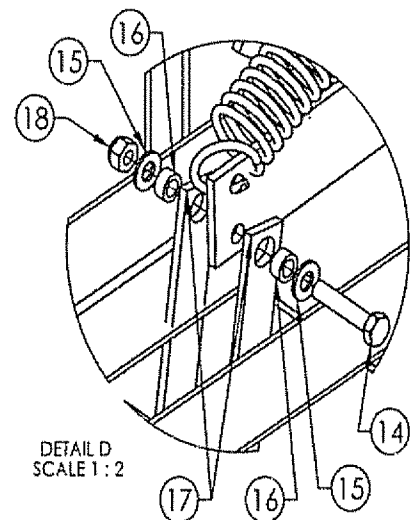
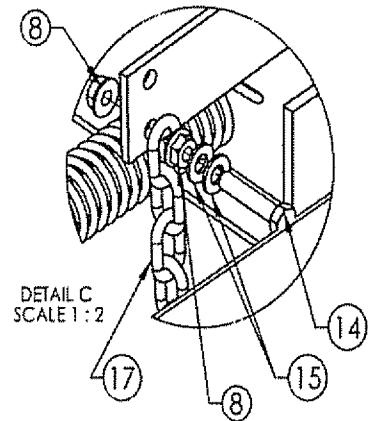
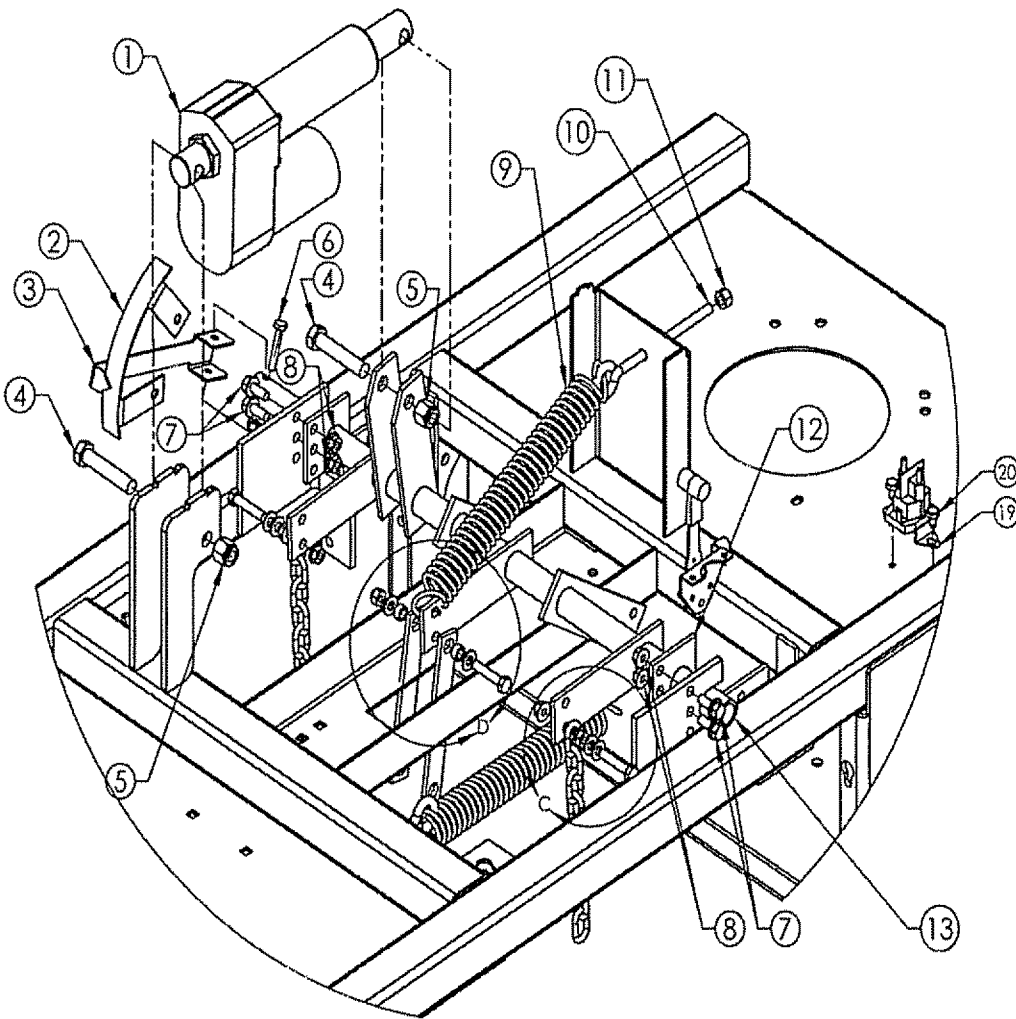

PARTS BREAKDOWN

Item #	Description	Part #
1	27 HP Engine	
2	5/16-18 Serrated Flange Nut	NB170
3	Spacer Engine Pulley	BB105SL
4	Pulley - Engine, 4.25"OD,1 1/4 ID	BB105
5	1/4 X 1/2 Key Stock	4258
6	Engine Pulley Spacer Short .687	689S
7	Electric Clutch	3813
8	Washer Belleville Engine Pulley	699
9	7/16-20 X 3.25 HCF GR5 ZP	NB705
10	5/16-18 X 1 1/4 Serrated Flange Bolt	NB253
11	Oil Drain Valve	AS122
12	Oil Drain Valve Cap	AS123

Not Shown

Description	Part #
Solenoid - 3 Pole	1002004
Wiring Harness	10264

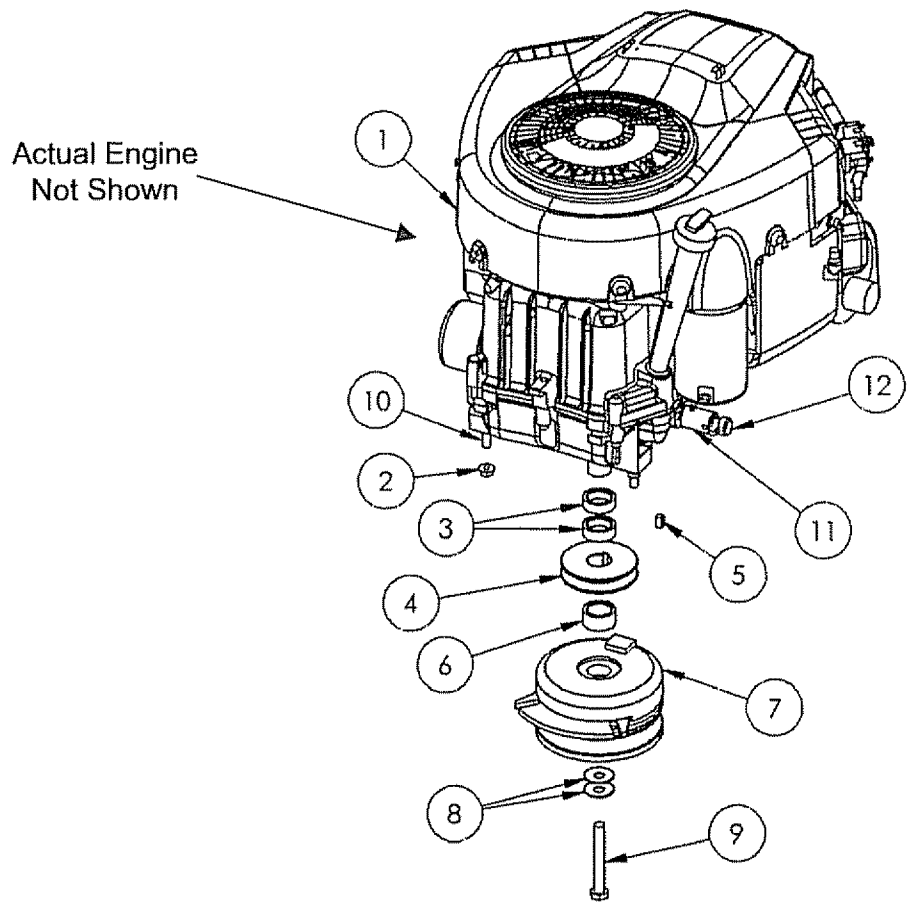

PARTS BREAKDOWN

ITEM#	DESCRIPTION	PART NO.
1	Shackle, Anchor 1/4 w/Round Pin	12957
2	Chain - Deck Hanger Two Links	12825
3	Nut, Nyloc 5/16-18 ZY	NB181
4	Bolt - Carriage 5/16-18 X 5	NB660
5	Bolt, Shoulder Cap Socket 5/16 X 1 3/4	12955
6	Deck - Lift Linkage Bar	12780
7	5/16 X 1 1/4 OD Fender Washer ZY	NB579
8	5/16-18 X 3 Eye Bolt w/Gap ZY	NB315
9	Clutch Rod Spring	682S
10	Bolt - 5/16-18 X 1 1/4 HCC GR5 ZY	NB504
11	5/16-18 X 3/4 Serr Flng Bolt	NB596
12	Lower Belt Idler Weldment	3691
13	Idler Pulley OD-2.75", ID-3/8"	7509
14	Nut, Lock 3/8-16 2-Way ZY	NB280
15	1/2-13 X 3 HCC GR5 Bolt ZY	NB131
16	Washer, 3/8 SAE ZY	NB272
17	Idler Pulley V OD-3.54", ID-3/8"	3622
18	3/8-16 HNC GR2 ZP	NB212
19	3/8-16 X 2 HTC GR5 ZY	NB231
20	Bracket - Deck Belt Idler, Swisher Pro	14683

ITEM#	DESCRIPTION	PART NO.
21	1/2-13 Nyloc Nut	NB281
22	Bolt - 3/8-16 X 1 3/4 HCC GR5 ZY	NB302
23	Idler Bushing	6040
24	Idler - Sliding Weldment	14696
25	Idler Bushing	6037
26	Deck - Lift Linkage Mount Plate	12779
27	Pin, Cotter 3/32 X 3/4 ZY	NB597
28	NUT .31-18 CENTERLOCK ZINC	015X88
29	Washer, 3/8 SAE ZY	NB272
30	Deck - Lift Linkage Mount Plate	12778
31	Nut, Nyloc 3/8-16 ZY	NB182

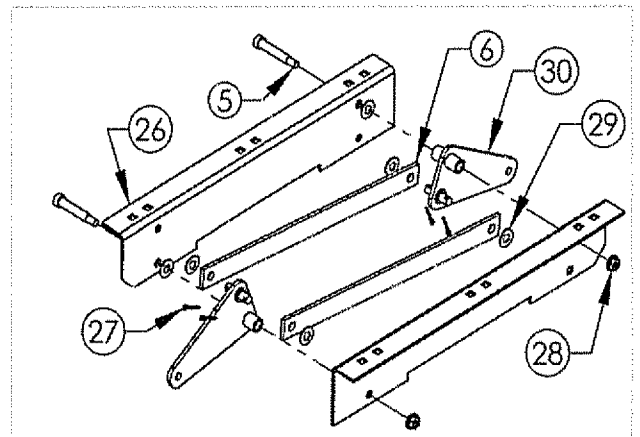
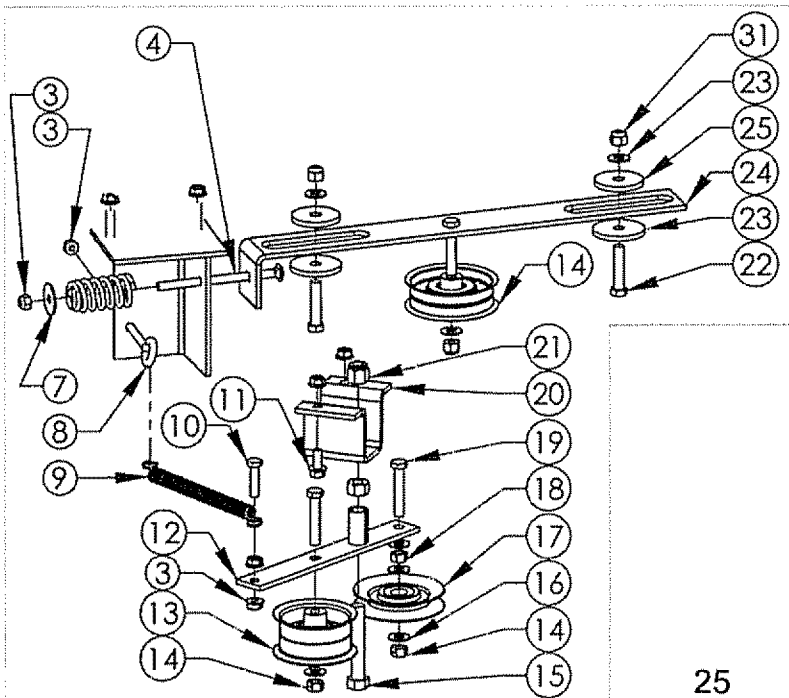
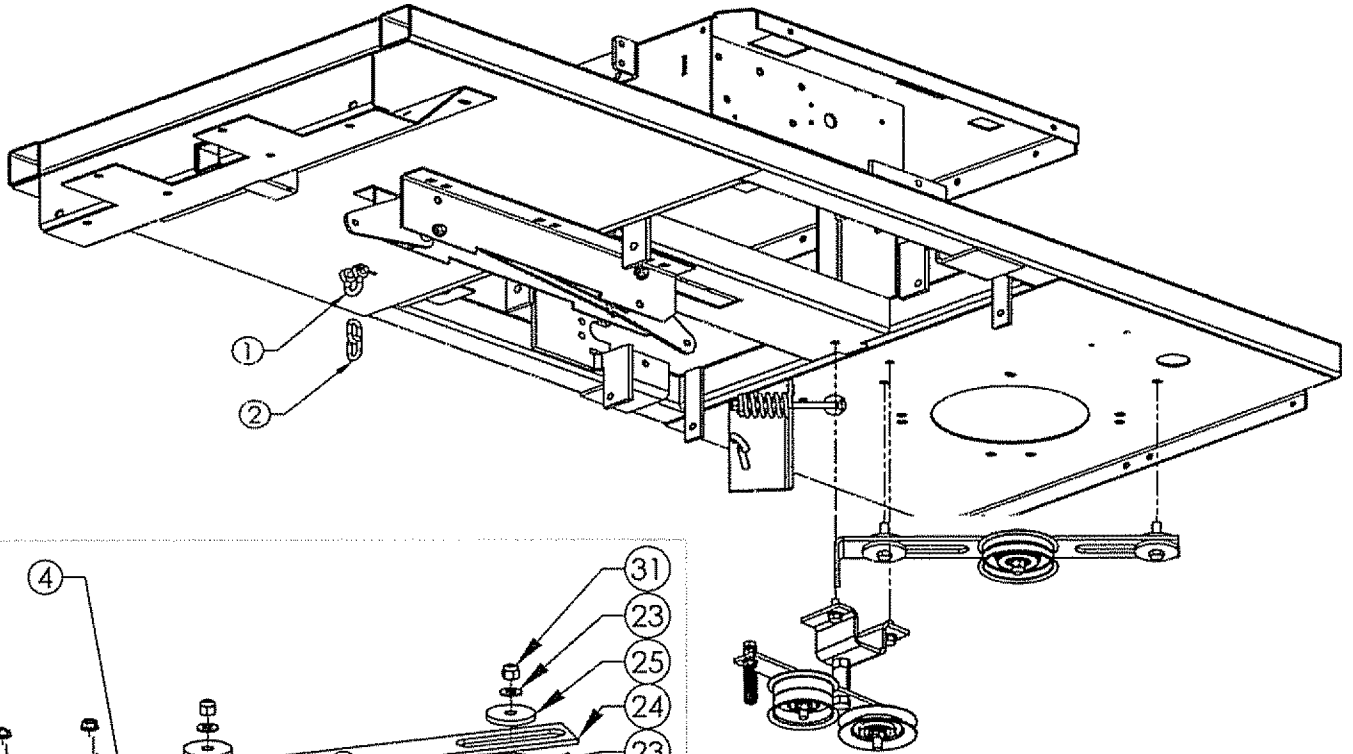

PARTS BREAKDOWN

Item #	Description	Part #
1	Shackel, Anchor 1/4 w/Round Pin	12957
2	Chain - Deck Hanger Two Links	12825
3	3/8-16 HNC GR2 ZP	NB212
4	3/8-16 X 5 Turned Eyebolt ZY	10546
5	Tilt Spring	2335
6	5/16-18 Serrated Flng Nut ZY	NB170
7	5/16-18 X 1 1/2 Flge Serr. Bolt	NB254
8	Deck Lift Weldment	14682
9	Bolt - 5/16-18 X 1 1/2 HCC GR5 ZY	NB505
10	5/16 SAE Washer ZY	NB275
11	Latch Pin Bushing	7839Z
12	Strap - Linkage	12878
13	Nut, Nyloc 5/16-18 ZY	NB181

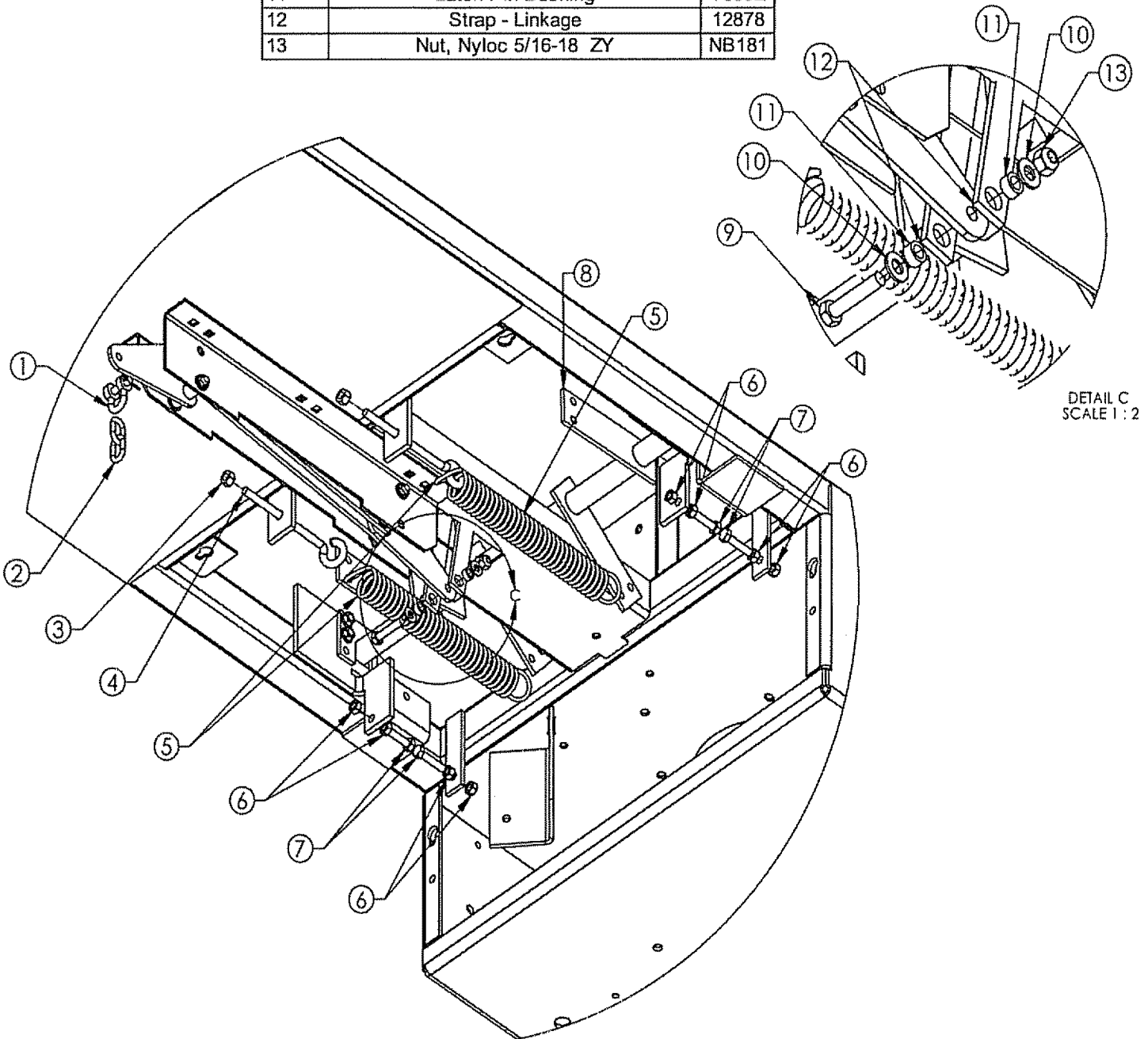

DETAIL C
SCALE 1 : 2

PARTS BREAKDOWN

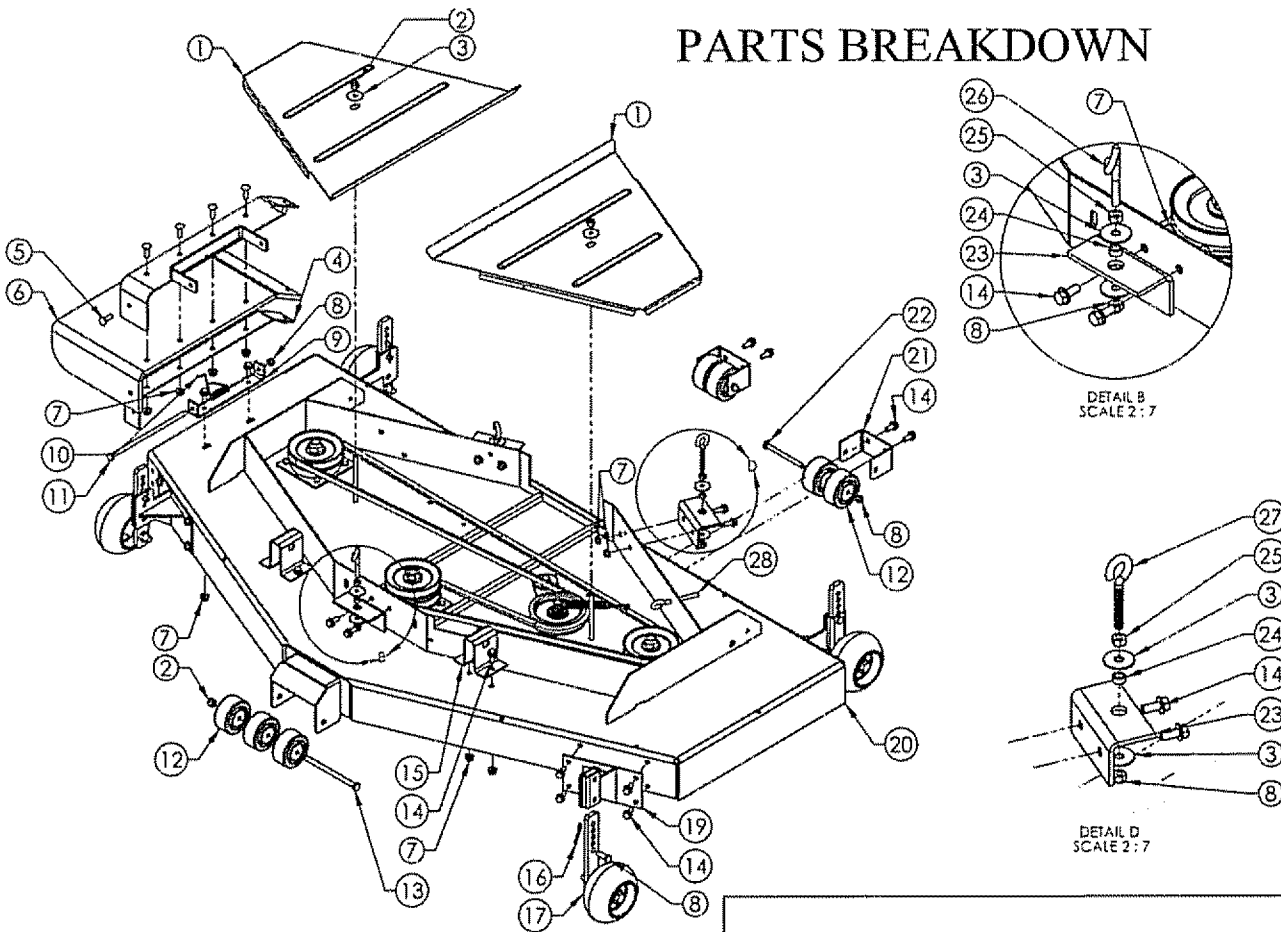

Item #	Description	Part #
1	Belt Cover	6025
2	Nut, Nyloc 3/8-16 ZY	NB182
3	5/16 X 1 1/4 OD Fender Washer ZY	NB579
4	Bracket - Grass Chute, Bottom	14256
5	5/16-18 X 1 Carriage Bolt GR5	10197
6	Rubber - Material, Grass Chute	14258
7	5/16-18 Serrated Fing Nut ZY	NB170
8	Nut, Nyloc 5/16-18 ZY	NB181
9	Grass Chute Mount - Deck	6030
10	SPRING, TORSION	166X34
11	5/16-18 X 8 1/2 HCC GR2 ZP	NB136
12	Anti-Scalp Roller 3/8 ID	AS001
13	3/8-16 X 5 1/2 GR5 ZY	NB575
14	5/16-18 X 3/4 Serr Fing Bolt	NB596
15	Deck Stabilizing Bracket	9977
16	Pin - Hair, #39 (A155H) ZY Std	NB127
17	Wheel - Roller, Sub-Assembly	3563
18	Wire Link For Idler Arm	BRS6H
19	Gauge - Wheel Weldment Left Front	12598
20	Deck - 66" Weldment, 7 GA; Mow-zilla	14269
21	Rear Roller Bracket	10775
22	Bolt, Carriage 5/16-18 X 4 ZY	NB101
23	Deck Hanger	9938
24	Latch Pin Bushing	7839Z
25	Nut - 5/16-18 HNC GR2 ZY	NB210Z
26	Eyebolt - Pigtail; 5/16-18 x 2 3/4" ZY	2046
27	Eyebolt - 5/16-18 X 2 , 1/2 Eye ZY STD	10198
28	5/16-18 X 3 Eye Bolt w/Gap ZY	NB315
29	Bolt - 3/8-16 X 1 1/4 GR5 ZY	NB618
30	Two Speed Spring	TZ2S
31	3/8-16 Jam Nut ZY	NB174

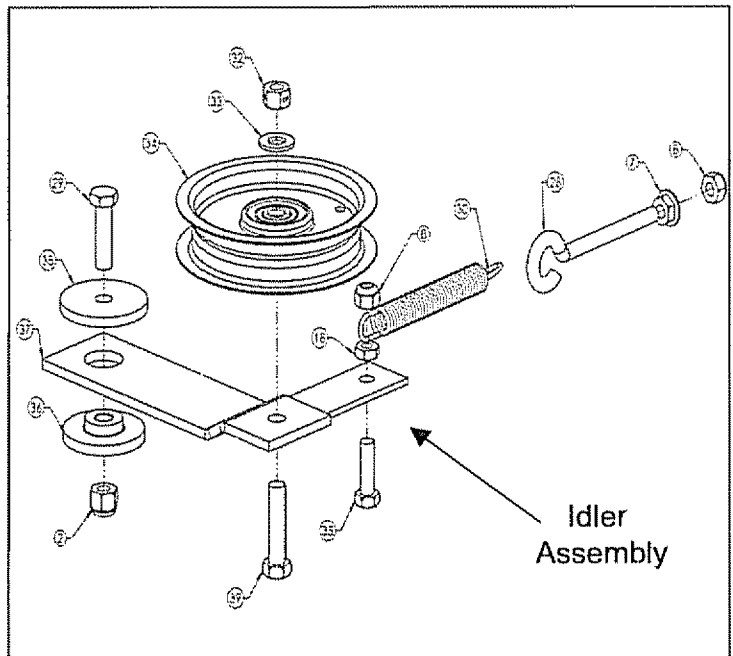

Item #	Description	Part #
32	Nut, Lock 3/8-16 2-Way ZY	NB280
33	Washer, 3/8 SAE ZY	NB272
34	Pulley - Backside Idler, ZT 08	14424
35	5/16-18 X 1 HCC GR5 ZY	NB501
36	Idler Bushing	6037
37	Idler - Bottom Weldment	6054
38	Idler Bushing	6040
39	3/8-16 X 1 1/2 HCC GR5 ZY	NB107

PARTS BREAKDOWN

1	3/4-16 Nut	NB175
2	Belleville Washer	AS155
3	Pulley 5 1/2"	6114TK
4	Spacer	12823
5	3/4 ID X 1 1/4 OD 18 GA Washer	NB179
6	Center Blade Driver	10541
7	Outer Blade Driver	10540
8	3/4 ID X 1 3/4 OD Flat Washer	B98W
9	Blade Mount Plate	9008
10	3/8-24 Two Way Lock Nut	NB216
11	Blade	12509
12	3/8-24 X 1 Bolt	NB238
13	Belleville Washer	NB607
14	Blade Bearing	B98
15	Shaft - Blade 6", Long Shoulder	9078
16	5" Blade Driver Shaft	9077
17	Blade Driver Housing	10539
18	3/8-24 X 1 Engine Bolt Locktite	NB238N

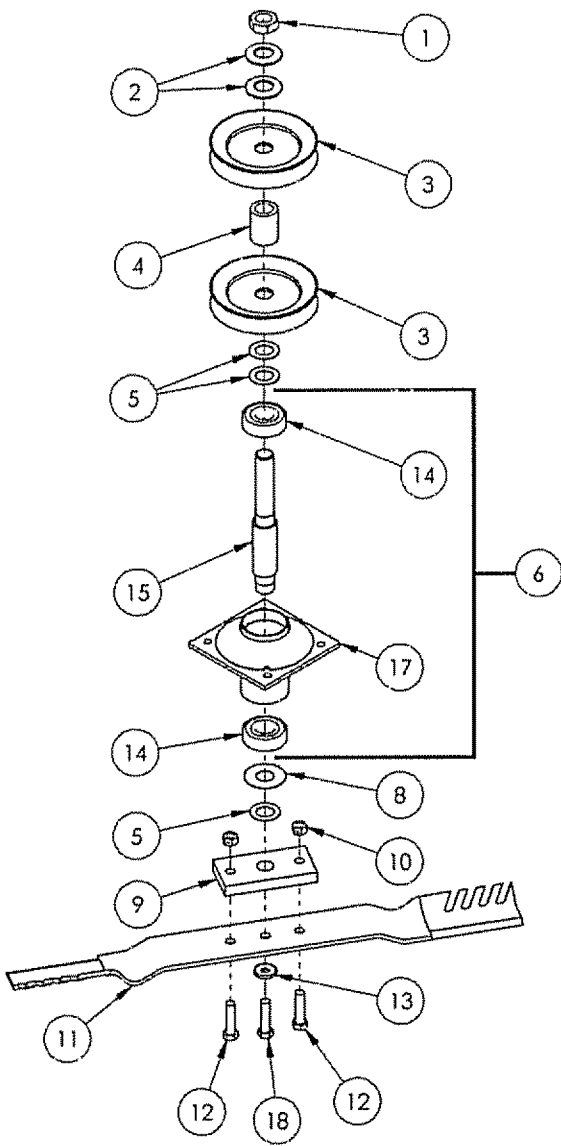

Center Driver

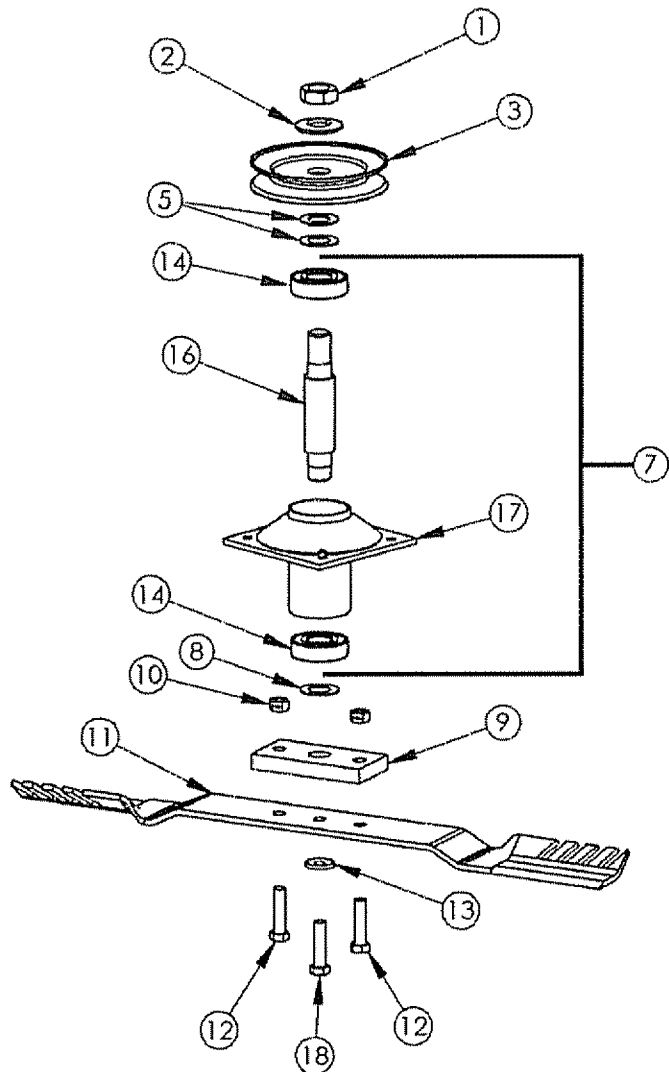

Outside Driver

PARTS BREAKDOWN

Item #	Description	Part #
1	Seat - Deluxe Suspension	14133
2	Strap - Gas Tank	14827
3	Bolt - 5/16-18 X 3/4 GR5 ZY	NB578
4	Gas Tank - Plastic, 6 Gallon NON-CARB	14762
5	Elbow For P-6102T	AS120
6	Bracket - Seat Mount; Mowzilla/ProSeries	14695
7	PTO Switch	3605
8	Key Switch	3623
9	1/4-20 X 1 1/2 HCCGR2ZP	NB104Z
10	Washer, 1/4 SAE	NB274
11	Seat Bushing	9931
12	Hour Meter	3803
13	SCREW- .312-18X.75	26X249
14	SCREW .31-18X0.75 WAHH	25X021
15	Washer - 3/8 lock, External Tooth; ZT	13045
16	Screw - 3/8-16 Rolok, Unslot HWH Z/Wax	13044
17	Wheel Hub - Asy	9920
18	8-32 X 1/2 Phil Truss ZY	NB197

Item #	Description	Part #
19	5/16-18 X 1 1/4 Serr. Flng Bolt ZY	NB253
20	1.5x.761x.098x.134 Belleville Washer	AS155
21	Nut - Castle, Wheel Hub; WT7002A	2203CN
22	Wheel Hub Lug Nut 1/2-20 ZY	2203LN
23	Gusset - Wrap Weldment	14686
24	Plate - Left Side, Super Duty ZTR	14177
25	Panel - Seat Base, Right; Super Duty ZTR	14178
26	Tire - Rear, 23 X 10.5 - 12	14138
27	Cable - Throttle (Not Shown)	3788

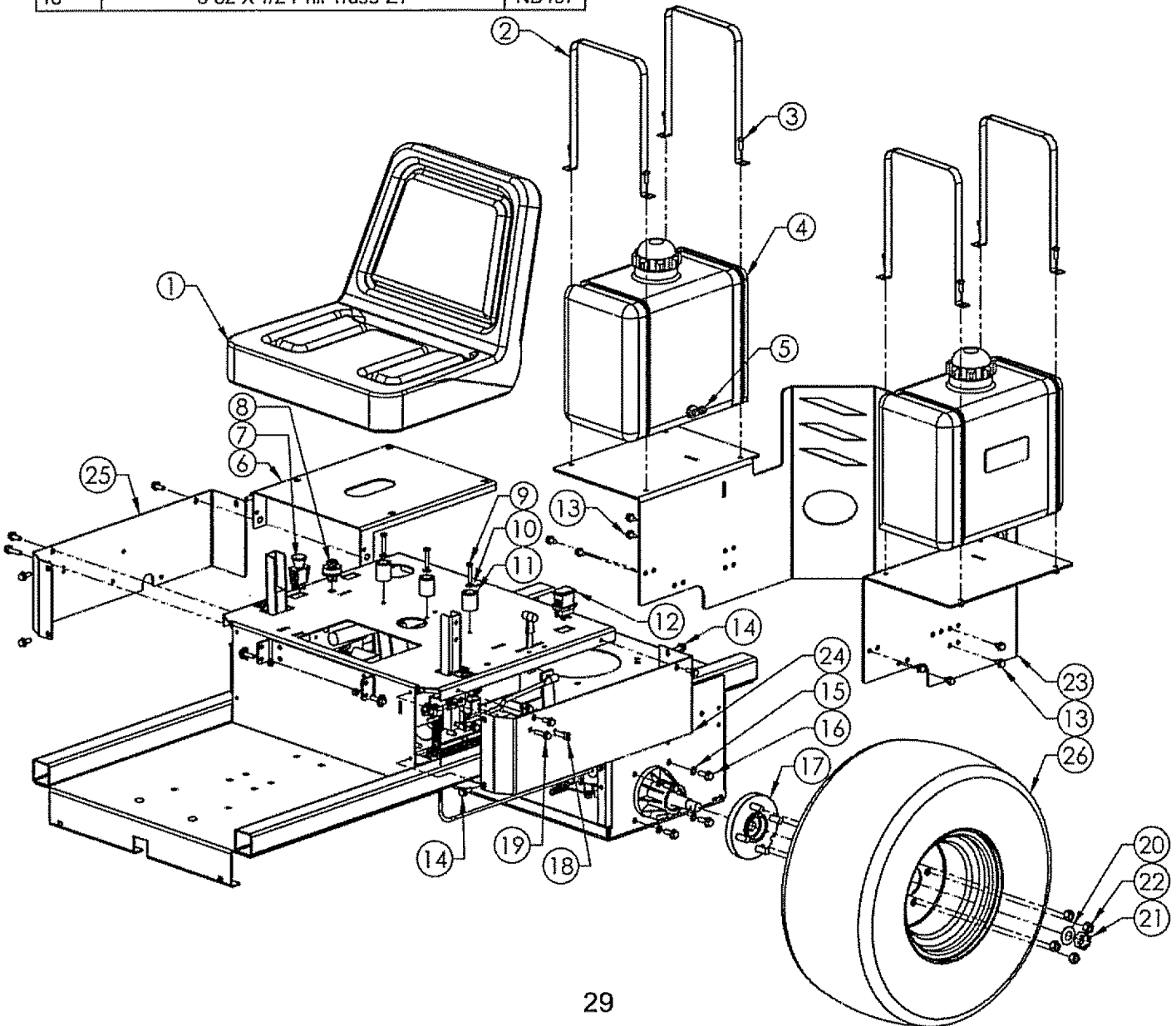

PARTS BREAKDOWN

Item #	Description	Part #
1	Bracket - Foot Rest	14163
2	Bolt - Carriage 5/16-18 X 3/4 GR5 ZY	10216
3	5/16-18 X 1 Serrated Flange GR5 2P	10548
4	Axle Washer	9915
5	Spacer	B99S
6	Pivot - Axle Weldment	12510
7	Bolt - HCC 5/8-11 X 8" GR 5, ZY	14430
8	Spacer - Wheel, 1.250"	14431
9	5/8 ID X 1 OD 10 GA Washer	NB178
10	Tire - Front; 13 X 650 - 6, Smooth	14137
11	5/8-11 2 Way Lock Jam Nut	NB595
12	5/16-18 X 3/4 Serr Flng Bolt	NB596
13	Deck Stabilizing Bar-YZ Plated	9949
14	Stabilizer Bracket - Left; 66" Pro	15314
15	Stabilizer Bracket - Right; 66" Pro	15313
16	Caster - Weldment; Mow-zilla	14259
17	13/16 X 1 1/4 X 1/8 Washer ZY	NB195
18	Blade Bearing	B98
19	Nut - Nylock Jam 3/4-10	NB313

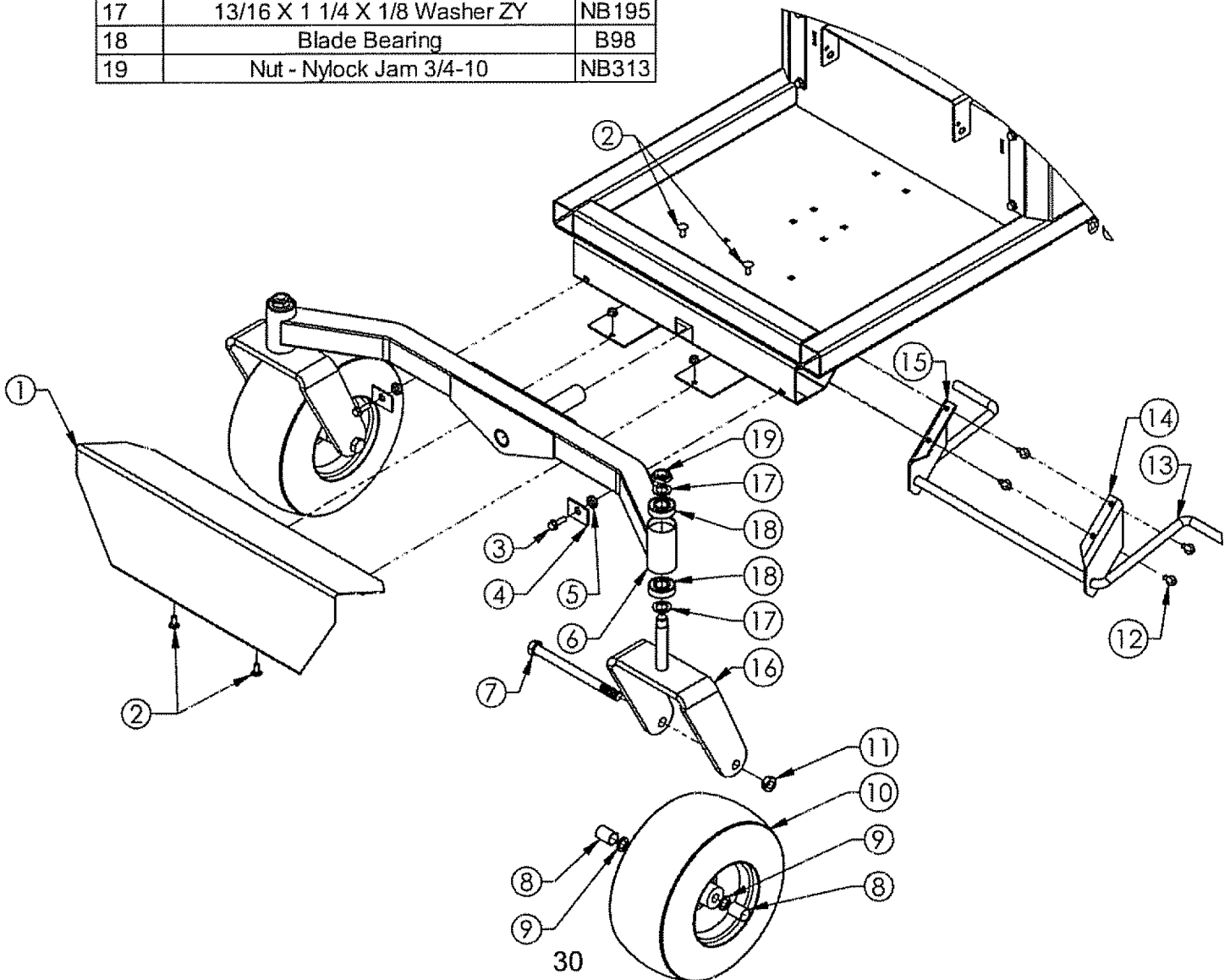

PARTS BREAKDOWN

Refer to pg. 32-33
for exploded views

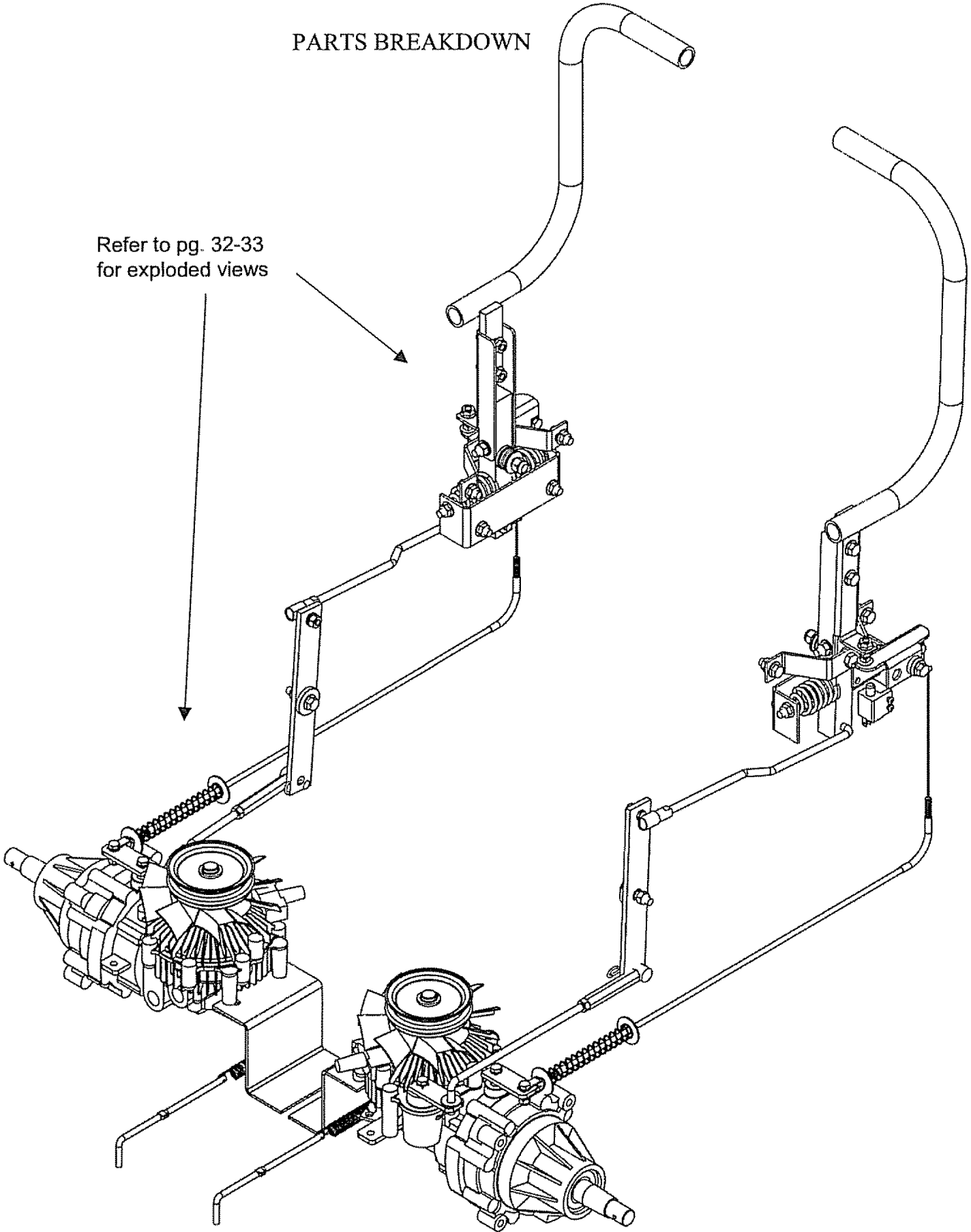

PARTS BREAKDOWN

Item #	Description	Part #
1	Nut, Nyloc 3/8-16 ZY	NB182
2	WASHER 39-1 14G FLT	17X104
3	SP Washer Bellm. PLN .413 X .945 X .118	NB607
4	WASHER, FLAT-DELTRIN	17X217
5	5/16-18 Serrated Flng Nut ZY	NB170
6	1" Directional Handle Weldment, Left	11769
7	Handle Pivot	9985
8	5/16-18 X 1 Serrated Flange GR5 2P	10548
9	5/16 SAE Washer ZY	NB275
10	Nut, Nyloc 5/16-18 ZY	NB181
11	5/16-18 X 3/4 Serr Flng Bolt	NB596
12	5/16-18 X 1 Carriage Bolt GR5	10197
13	Safety Switch Rocker Arm	9925
14	Spacer	B99S

Item #	Description	Part #
15	5/16-18 X 1 1/4 Serr. Flng Bolt ZY	NB253
16	5/16 SAE Washer ZY	NB275
17	1/4-20 Nylok Nut	NB180
18	Nut, Nyloc 5/16-18 ZY	NB181
19	Clutch Cable Clevis T44CH	9023
20	1/4-20 X 3/4 GR5 ZY	NB250
21	Control Arm	9986
22	Tapered Spring	3609
23	Bracket, 5.5" Neutral	10899
24	1" Directional Handle Weldment, Right	11768

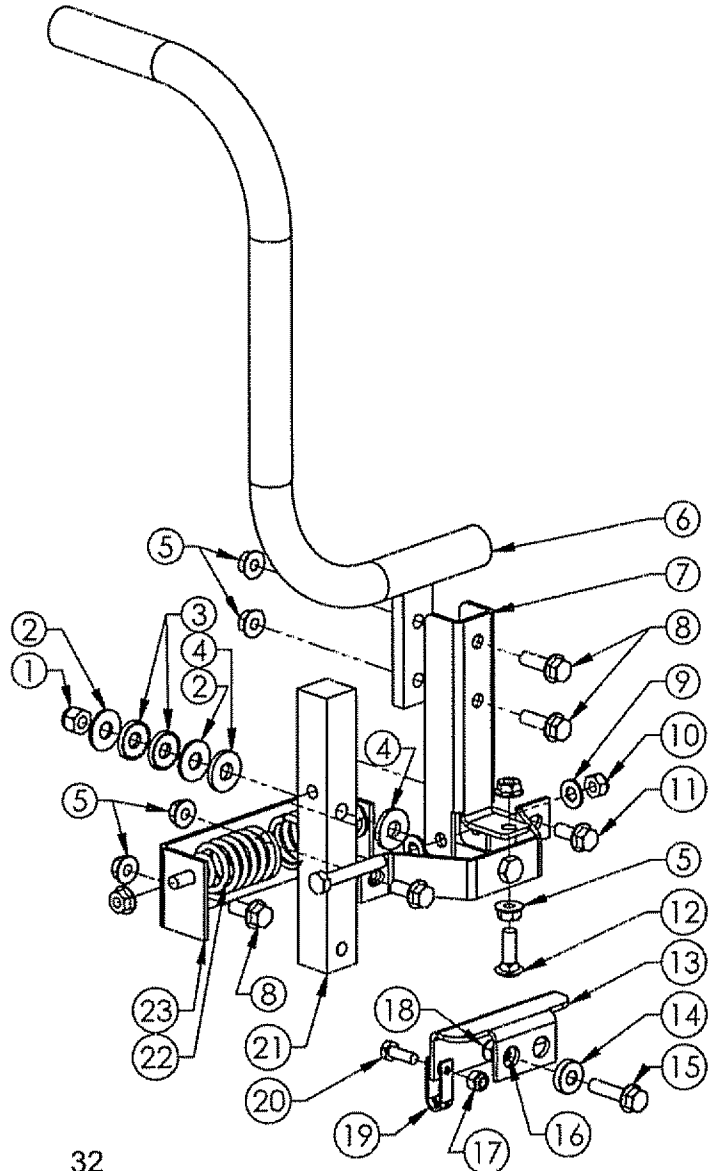
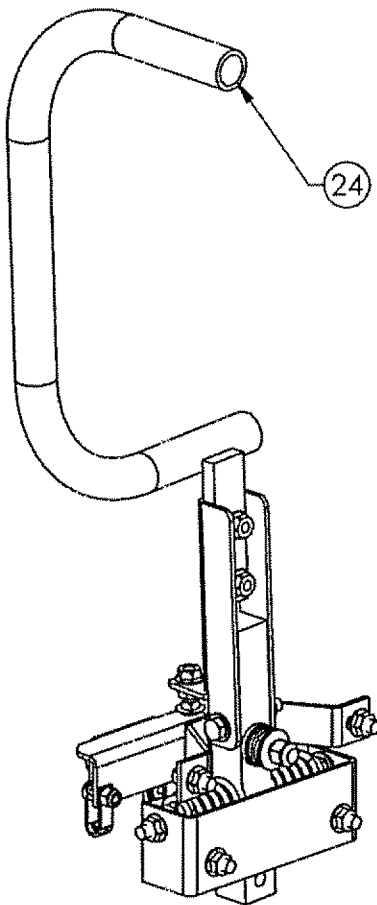

PARTS BREAKDOWN

Item #	Description	Part #
1	Linkage - Steering' 9" X 1.25"	14032
2	Connector	14028
3	Hydro Linkage Right Weldment	14058
4	Hydro Linkage Left Weldment	14060
5	Bolt - 1/4-28 X 3/4 GR5 ZY	NB620
6	Washer - 1/4" Belleville	14399
7	Pin - Hair, #39 (A155H) ZY Std	NB127
8	Cable - Parking Brake, Assy	9976
9	Linkage - Shift	9919
10	Bushing - Latch Pin	7839Z
11	Washer - SAE Flat 5/16 ZY	NB275
12	Pin - Cotter, 1/8 X 3/4 ZY Std	NB125
13	Washer - Fender, 5/16 X 1 1/4 OD ZY GR2	NB579
14	Spring - Parking Brake	10536

Item #	Description	Part #
15	Clevis - Clutch Cable; T44CH	9023
16	Nut - Nylock 1/4-20	NB180
17	Hydro - Eaton RH W Reservoir	14134
18	Plate - Hydro Release	9924
19	Washer - SP Wave 5/16 X 7/10 X .006 GR	10544
20	Screw - Thread Forming	26X216
21	Screw - .312-18X.75	26X249
22	Spring - For Idler Arm	BRS6
23	Support - Hydro	13082
24	Handle - Hydro Release	9923
25	Washer - SAE Flat 5/16 ZY	nb275
26	Hydro - Eaton LH W/Reservoir	14135

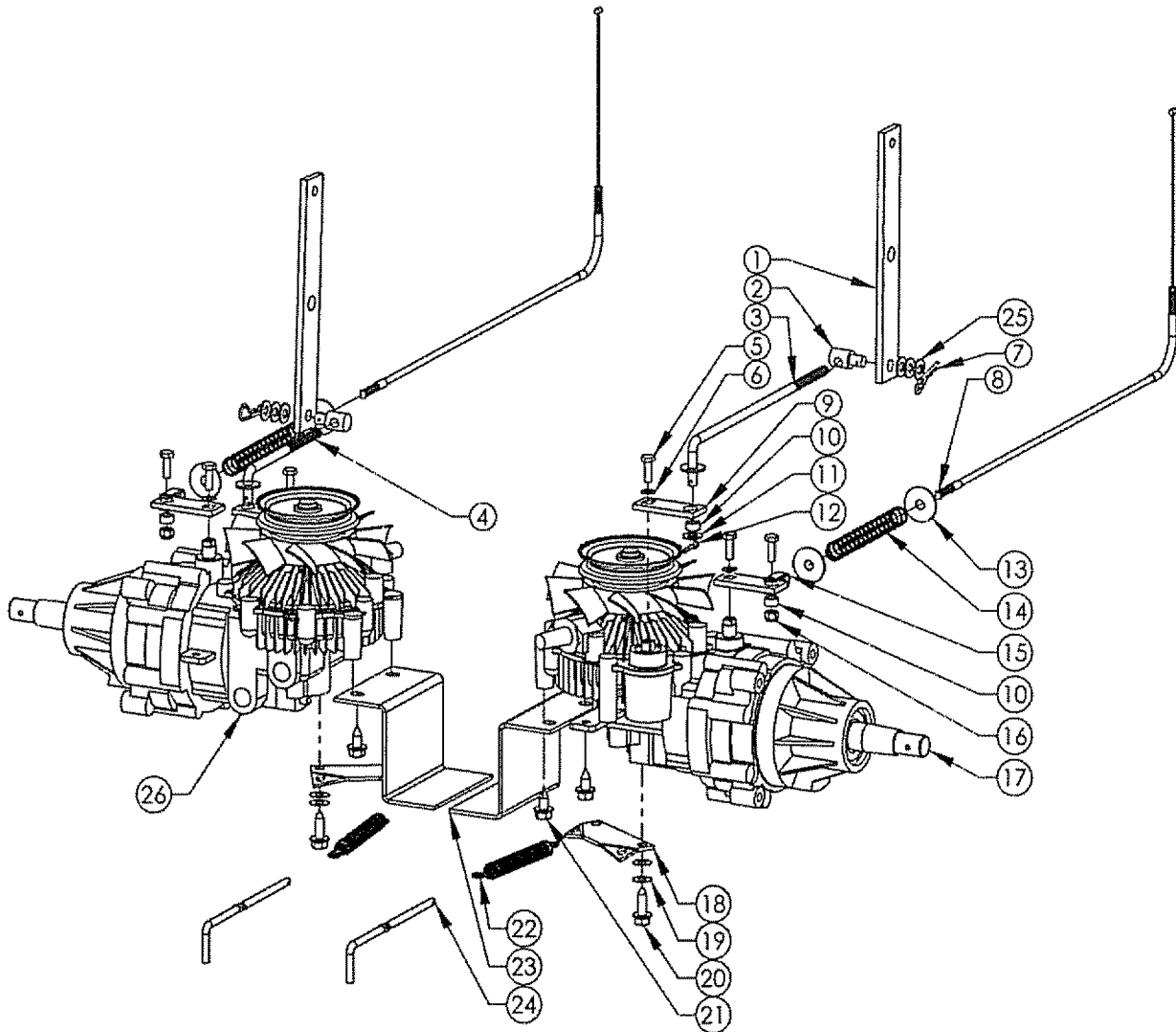

TROUBLESHOOTING

PROBLEM	CAUSE	CORRECTION
Engine Will Not Start	<ol style="list-style-type: none"> 1. Out of fuel 2. Engine not "choked" properly 3. Engine flooded 4. Bad spark plug 5. Dirty air filter 6. Dirty fuel filter 7. Water in fuel 8. Loose or damaged wiring 9. Carburetor out of adjustment 10. Engine valves out of adjustment 11. Extreme cold conditions 12. Fuel shut off valves closed 	<ol style="list-style-type: none"> 1. Fill fuel tank 2. Choked engine and attempt to restart 3. Wait several minutes before attempting to restart. 4. Replace spark plug 5. Clean or replace air filter 6. Replace fuel filter 7. Drain fuel tank & carburetor, refill tank with fresh gas and replace fuel filter 8. Check all wiring 9. See Engine Manual 10. Contact an authorized service center 11. See Engine Manual 12. Open
Engine Hard To Start	<ol style="list-style-type: none"> 1. Bad spark plug 2. Dirty air filter 3. Dirty fuel filter 4. Weak or dead battery 5. Carburetor out of adjustment 6. Engine valves out of adjustment 7. Loose or damaged wiring 8. Stale or dirty fuel 	<ol style="list-style-type: none"> 1. Replace spark plug 2. Clean or replace air filter 3. Replace fuel filter 4. Recharge or replace battery 5. See Engine Manual 6. Contact an authorized service center 7. Check all wiring 8. Drain fuel tank & refill with fresh gasoline
Engine Will Not Turn Over	<ol style="list-style-type: none"> 1. Directional handles not in correct position 2. PTO engaged 3. Weak or dead battery 4. Blown fuse 5. Corroded battery terminals 6. Loose or damaged wiring 7. Faulty ignition switch 8. Faulty solenoid 9. Faulty operator presence switch/switches 	<ol style="list-style-type: none"> 1. Place handles in the out most position 2. Push PTO switch down 3. Recharge or replace battery 4. Replace fuse! 5. Clean battery terminals – See battery section of this manual 6. Check all wiring 7. Check/replace ignition switch 8. Check/replace solenoid 9. Contact an authorized service center
Engine Clicks but Will Not Start	<ol style="list-style-type: none"> 1. Weak or dead battery 2. Corroded battery terminals 3. Loose or damaged wiring 4. Faulty solenoid 	<ol style="list-style-type: none"> 1. Recharge or replace battery 2. Clean battery terminals – See battery section of this manual 3. Check all wiring 4. Check/replace solenoid
Unit Does not Travel in a straight line	<ol style="list-style-type: none"> 1. Incorrect tire pressure 2. Rear wheels rotating at different speeds 	<ol style="list-style-type: none"> 1. Check tire pressure (See Specifications) 2. Adjust travel reduction weldment
Excessive Vibration	<ol style="list-style-type: none"> 1. Worn, bent or loose blade 2. Bent blade driver 3. Loose/damage part or parts 4. Faulty blade driver assembly 	<ol style="list-style-type: none"> 1. Replace blade. Tighten blade bolt. 2. Replace blade driver 3. Tighten loose part or parts. Replace damaged parts. 4. Replace blade driver assembly

TROUBLESHOOTING Continued

PROBLEM	CAUSE	CORRECTION
Loss of Power	<ol style="list-style-type: none"> 1. Cutting too much grass/ too fast 2. "Choke" position 3. Buildup of grass, leaves and trash under deck. 4. Dirty air filter 5. Low oil level/dirty oil 6. Faulty spark plug 7. Dirty fuel filter 8. Stale or dirty fuel 9. Water in fuel 10. Spark plug wire loose 11. Dirty engine air screen/fins 12. Dirty/clogged muffler 13. Loose or damaged wiring 14. Carburetor out of adjustment 15. Engine valves out of adjustment 16. Loose drive belt 	<ol style="list-style-type: none"> 1. Set in High Cut (position 8)/reduce speed 2. Push choke control in 3. Clean underside of mower deck 4. Clean or replace air filter 5. Check oil level/change oil 6. Clean and re-gap or change plug 7. Replace fuel filter 8. Drain fuel tank & refill tank with fresh gas 9. Drain fuel tank & carburetor, refill tank with fresh gas and replace fuel filter 10. Connect and tighten spark plug wire 11. Clean engine air screen/fins 12. Clean/replace muffler 13. Check all wiring 14. See Engine Manual 15. Contact an authorized service center 16. Adjust idler/replace belt
Engine backfires when turning engine OFF	<ol style="list-style-type: none"> 1. Engine throttle control not set at "SLOW" position for 30 seconds before stopping engine. 	<ol style="list-style-type: none"> 1. Move throttle control to "SLOW" position and allow to idle for 30 seconds before stopping engine
Poor cut - uneven	<ol style="list-style-type: none"> 1. Worn, bent or loose blade 2. Mower deck not level 3. Buildup of debris under deck. 4. Bent deck 5. Faulty Blade driver assembly 	<ol style="list-style-type: none"> 1. Replace blade. Tighten blade bolt 2. Level deck. See section in this manual 3. Clean underside of mower deck 4. Replace deck 5. Replace blade driver assembly
Poor cut - uneven	<ol style="list-style-type: none"> 1. Worn, bent or loose blade 2. Mower deck not level 3. Buildup of grass, leaves and trash under deck. 4. Bent deck 5. Faulty Blade driver assembly 	<ol style="list-style-type: none"> 1. Replace blade. Tighten blade bolt 2. Level deck. See section in this manual 3. Clean underside of mower deck 4. Replace deck 5. Replace blade driver assembly
Battery will not charge	<ol style="list-style-type: none"> 1. Bad battery 2. Poor cable connections 3. Faulty solenoid 	<ol style="list-style-type: none"> 1. Replace battery 2. Check/clean all connections. See section in this manual 3. Replace solenoid
Loss of drive	<ol style="list-style-type: none"> 1. Bypass linkages in the bypass position 2. Hydro belt worn, damaged, or broken 3. Idler spring loose or broken 	<ol style="list-style-type: none"> 1. Make sure that the bypass linkages are in the drive or engaged position. Located at the rear of the machine. Refer to decal on the rear of the unit. 2. Replace Hydro belt 3. Replace Idler spring

Mower Identification

Each mower has its own model number. Each engine has its own model number. The model number for the mower will be found under the seat. The model number for the engine will be found on the top of the blower fan housing. All mower parts listed herein may be ordered directly from Swisher Mower & Machine Co. Inc. or your nearest Swisher dealer. All engine parts may be ordered from the nearest dealer of the engine supplied with your mower.

Unauthorized Replacement Parts

Use only Swisher replacement parts. The replacement of any part on this unit with anything other than Swisher authorized replacement part may adversely affect the performance, durability and safety of this unit and may void the warranty. Swisher disclaims liability for any claims or damages, whether warranty, property damage, personal injury or death arising out of the use of unauthorized replacement parts.

WHEN ORDERING PARTS, PLEASE HAVE THE FOLLOWING INFORMATION AVAILABLE:

- Date Purchased _____
- Purchased From _____
- PRODUCT – ZT2766KP
- SERIAL NUMBER - _____
- MODEL NUMBER - _____
- ENGINE MODEL NUMBER - _____
- TYPE - _____
- PART NUMBER WITH PAINT CODE _____
- *PART DESCRIPTION _____

SWISHER MOWER & MACHINE CO. INC.
1602 CORPORATE DRIVE
P.O. BOX 67
WARRENSBURG, MO 64093

Swisherinc.com
TELEPHONE - 1-800-222-8183
FAX - 1-660-747-8650

Cust.serv@swisherinc.com

Replacement Parts

Quick Reference

Swisher Part #	Part Description
AS069	Fuse 10 Amp
037X66	Belt Transmission
14138	Tire - Rear; 23 X 10.5 - 12
12527	137" Deck Belt
12509	22.5 Mulching Blade
14454	Belt – Engine to Deck
10540	Blade Driver Assembly (outside)
10541	Blade Driver Assembly (center)



CAUTION

Use extreme care when working on machinery.

Before performing any maintenance, turn off engine, allow the unit to cool & remove the key. Disconnect spark plug wire.

Set Parking Brake by placing the control handles in the neutral or outward position.

Do not wear watch or jewelry. Do not wear loose fitting clothes. Observe all common safety practices with tools.

WARRANTY RIGHTS AND OBLIGATIONS

YOUR WARRANTY RIGHTS AND OBLIGATIONS: The California Air Resources Board and Swisher Mower, is pleased to explain the evaporative emission control system (EECS) on your model year 2006 and later Swisher Product. In California, new Outdoor Power Equipment, must be designed, built and equipped to meet the State's stringent anti-smog standards. Swisher Mower must warrant the EECS on your Power Equipment, for the period of time listed below provided there has been no abuse, neglect, or improper maintenance. For model year 2006 the EECS on your mower includes the liquid fuel lines, fuel line connectors, and fuel line clamps. Where a warrantable condition exists, Swisher Mower will repair at no cost to you. Expenses covered under warranty include diagnosis, parts, and labor.

MANUFACTURER'S WARRANTY COVERAGE: For a period of two years, any evaporative emission-related part included in the list of EECS parts for your mower is defective, the part will be repaired or replaced by Swisher Mower.

OWNER'S WARRANTY RESPONSIBILITIES: As the owner of this Power Equipment, you are responsible for performance of the required maintenance listed in your owner's manual. Swisher Mower recommends that you retain all receipts covering maintenance on your Power Equipment, but Swisher Mower cannot deny warranty solely for the lack of receipts. As the Power Equipment owner, you should be aware that Swisher Mower, may deny you warranty coverage if your Power Equipment, or a covered part has failed due to abuse, neglect, or improper maintenance, unapproved modifications, or the use of parts not made or approved by the equipment manufacturer. You are responsible for presenting your Power Equipment to an authorized Swisher Service center as soon as the problem exists. Warranty repairs should be completed in a reasonable amount of time, not to exceed 30 days. If you have a question regarding your warranty rights and responsibilities, you should contact the Swisher Mower Service representative at 1-800-222-8183.

WARRANTY COMMENCEMENT DATE: The warranty period begins on the date the Power Equipment is purchased.

LENGTH OF COVERAGE: This warranty shall be for a period of two (2) years from the initial date of purchase.

WHAT IS COVERED: Warranted parts include the Liquid fuel line, fuel line connectors, and fuel line clamps.

REPAIR OR REPLACEMENT OF PARTS: Repair or replacement of any evaporative warranted part will be performed at no charge to the owner at an authorized Swisher Mower Service Center. If you have a question regarding your warranty rights and responsibilities, you should contact your nearest authorized service center or call the Swisher Mower Service representative at 1-800-222-8183.

WARRANTY PERIOD: Any warranted part is not scheduled for replacement as required maintenance, or which is scheduled only for regular inspection to the effect of "repair or replace as necessary" shall be warranted for two (2) years. Any warranted part that is scheduled for replacement as required maintenance shall be warranted for the period of time up to the first scheduled replacement point for that part.

DIAGNOSIS: The owner shall not be charged for diagnostic labor that leads to the determination that a warranted part is defective if the diagnostic work is performed at an authorized Swisher Service Center.

CONSEQUENTIAL DAMAGE: Swisher Mower, may be liable for damages to other engine or equipment components caused by the failure of a warranted part still under warranty.

WHAT IS NOT COVERED: All failures caused by abuse, neglect, or improper maintenance is not covered.

ADD-ON OR MODIFIED PARTS: The use of add-on or modified parts may be grounds for disallowing a warranty claim. Swisher Mower is not liable to cover failures of warranted parts caused by the use of an add-on or modified part.

HOW TO FILE A CLAIM: If you have a question regarding your warranty rights and responsibilities, you should contact your nearest authorized service center or call Swisher Mower Service representative at 1-800-222-8183.

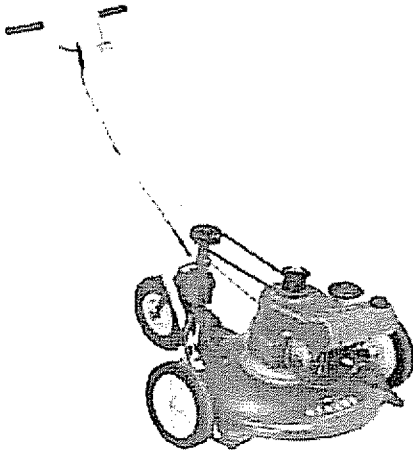

SWISHER HISTORY

Back before electricity came to rural Missouri Max Swisher was producing lawn mowers from his mother's chicken house. Max never liked to mow grass. He installed a gearbox on his family's lawn mower creating a self-propelled unit. By tying one end of a rope to the mower and the other end to a tree in the center of the yard the mower circled the tree, shortening the rope and guiding the mower in concentric circles. Max enjoyed relaxing under a shade tree while his invention did all the work.

Max had designed his first self-propelled rotary lawn mower to do his dirty work for him. Neighbors noticed his new invention and began asking him to make more. Today, over 60 years later, Swisher Mower and Machine Company, Inc. is still producing innovative lawn and garden and ATV/UTV equipment designed to give us all more "relaxing in the shade" time.

Swisher products have been featured nationally on television programs such as Regis and Kathie Lee and seen in publications like ATV Magazine, Country Journal, Popular Mechanics Magazine and others. In January 2000 Popular Mechanics Magazine named Max's zero turning radius riding mower one of the 20th century's top household inventions.

Swisher offers value and function in its products to meet your grounds maintenance needs.

CELEBRATING OVER 60 YEARS OF INNOVATION

1945 - 2008



Get it fixed, at your home or ours!

Your Home

For expert troubleshooting and home solutions advice:

manage  home

www.managemyhome.com

For repair – **in your home** – of **all** major brand appliances, lawn and garden equipment, or heating and cooling systems, **no matter who made it, no matter who sold it!**

For the replacement parts, accessories and owner's manuals that you need to do-it-yourself.

For Sears professional installation of home appliances and items like garage door openers and water heaters.

1-800-4-MY-HOME[®] (1-800-469-4663)

Call anytime, day or night (U.S.A. and Canada)

www.sears.com www.sears.ca

Our Home

For repair of carry-in items like vacuums, lawn equipment, and electronics, call anytime for the location of your nearest

Sears Parts & Repair Service Center

1-800-488-1222 (U.S.A.) **1-800-469-4663** (Canada)

www.sears.com www.sears.ca

To purchase a protection agreement on a product serviced by Sears:

1-800-827-6655 (U.S.A.)

1-800-361-6665 (Canada)

Para pedir servicio de reparación a domicilio, y para ordenar piezas:

1-888-SU-HOGAR[®]

(1-888-784-6427)

Au Canada pour service en français:

1-800-LE-FOYER^{MC}

(1-800-533-6937)

www.sears.ca



® Registered Trademark / TM Trademark / SM Service Mark of Sears Brands. LLC

® Marca Registrada / TM Marca de Fábrica / SM Marca de Servicio de Sears Brands. LLC

^{MC} Marque de commerce / ^{MD} Marque déposée de Sears Brands. LLC

© Sears Brands, LLC