

SEARS Kenmore

CONTENTS

SAFETY

..... 1-3

USE AND CARE

Features of Your Counter Unit 4
To Start Things Cooking 4
Cleaning Tips 5
Removable Parts 6

BEFORE CALLING FOR SERVICE

What to Do Before Calling for Service 7
Customer Service Numbers 8

WARRANTY

MODELS 43420, 43421
43427, 43455
43456, 43459

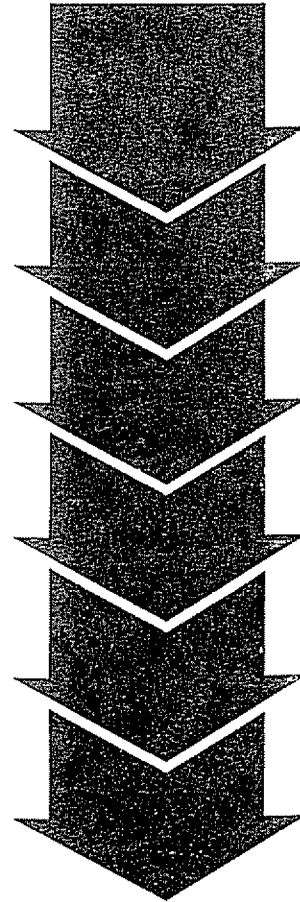

USE • CARE • SAFETY MANUAL



MNM240-3 SR10080

IMPORTANT IMPORTANT IMPORTANT IMPORTANT IMPORTANT IMPORTANT IMPORTANT IMPORTANT IMPORTANT

IMPORTANT INSTRUCTIONS FOR YOUR SAFETY

SAVE THESE INSTRUCTIONS

Read all instructions before using this appliance. When using electrical/gas appliances, basic safety precautions should be followed, including the following:

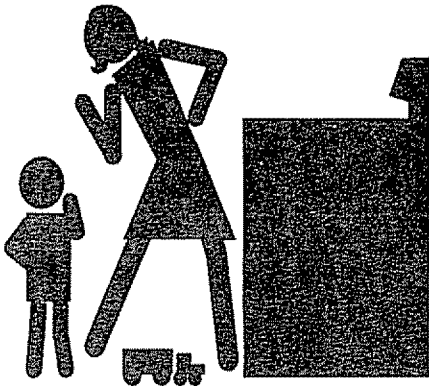

Teach children not to play with control knobs or any other part of the counter unit.

Never leave children alone or unattended where a counter unit is in use.

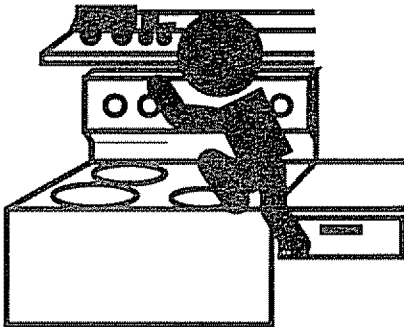
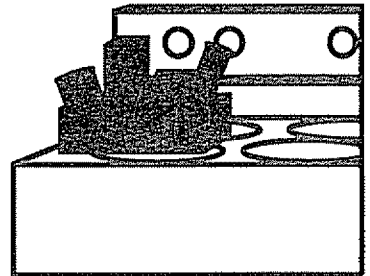

Caution:

Never store things children might want above a counter unit.

Never let anyone climb, sit or stand on the counter unit. They might be injured on a hot surface.

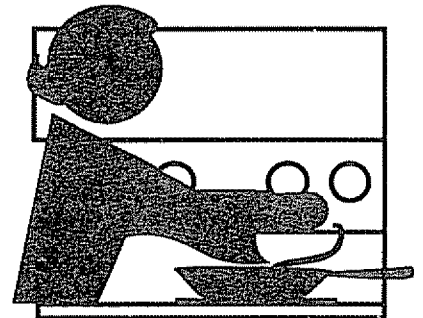

Never let pot handles stick out over the front of the counter unit. Turn handles in so that they cannot be bumped. Keep the handles away from other hot surface elements/burners.



IMPORTANT IMPORTANT IMPORTANT IMPORTANT IMPORTANT IMPORTANT IMPORTANT IMPORTANT IMPORTANT

To insure safety for yourself and your home, please read your Owner's Manual carefully. Keep it handy for quick easy reference. Pay close attention to the safety sections of your manual. You can recognize the safety sections by looking for the  symbol or the word "Safety".

Always keep the counter unit area clear and free from things that will burn.

CAUTION:

Never store things near cooktop elements/burners. These things may catch fire and plastic items could melt.

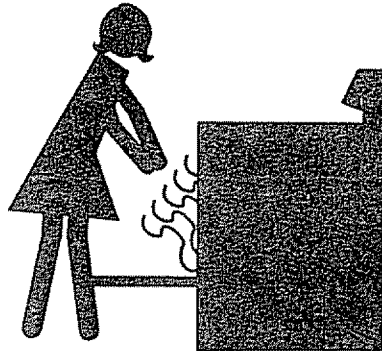

Never use your counter unit for warming or heating a room. You could be burned or seriously injured. Such misuse could also cause damage to the unit.

Never wear loose clothing when using your counter unit. Such clothing could catch fire.



Never use a towel or other bulky cloth as a potholder. Such cloths could catch fire on a hot element/burner.

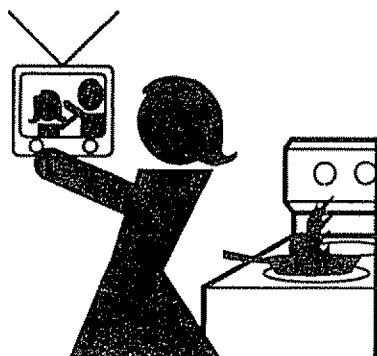

Never leave cooktop elements/burners unwatched at high heat settings. Boilovers cause smoking and greasy spillovers could catch fire.

IMPORTANT SAFETY INSTRUCTIONS

Keep this book for later use.

Be sure your counter unit is installed and grounded properly by a qualified technician.

Choose pots and pans with flat bottoms, large enough to cover the entire cooktop element. This will cut down the risk of setting potholders or clothing on fire with an uncovered element and waste less energy.

Always use care when touching the cooktop. The glass surface of the counter unit will retain heat after controls have been turned off. Be careful not to get burned.

Only some kinds of glass or ceramic pans can be used for cooktop cooking. Be sure that the pan you use will not break when heated on the cooktop elements.

Always use dry potholders when removing pans from the elements. Moist or damp potholders can cause steam burns.

Always follow cleaning instructions in this book.

Always keep the cooktop area clear and free from things that will burn, gasoline and other flammable vapors and liquids.

Always keep the counter unit clean. Food and grease are easy to ignite. Clean counter unit and vent hoods regularly.

Always keep combustible wall coverings, curtains or drapes a safe distance away from your counter unit.

Always keep dish towels, dish cloths, potholders and other linens a safe distance away from your counter unit. Never store such items on your counter unit.

Always keep wooden and plastic utensils or canned food a safe distance away from your counter unit.

Never put removable heating elements in water. Don't put them in a dishwasher.

Never try to repair or replace any part of the Counter Unit unless instructions are given in this book. All other work should be done by a skilled technician.

Never heat unopened food containers. Pressure buildup may make container burst and cause injury.

Never leave jars or cans of fat or drippings on or near the Cooktop. Never let grease build up on your Counter Unit. You can keep grease fires from starting if you clean up grease and spills after each use.

Never try to move a pan of hot fat, especially a deep fat fryer. Wait until the fat has cooled.

Never clean cooktop surface when it is hot. Some cleaners produce noxious fumes and wet cloths could cause steam burns if used on a hot surface.

Never touch surface units; they may be hot even though they appear dark in color.

Never use the open coil elements without reflector pans or drip bowls in place. If these pans or bowls are not there during cooking, wiring or other range parts may be damaged.

Never use aluminum foil to line drip bowls. Improper use of foil could start a fire or cause electrical shock.

FIRE!

Read and understand this information NOW! Should you ever need it, you will not have time for reading.

Never use water on a grease fire - it will only spread the flames.

COOKTOP GREASE FIRE

Never pick up a flaming pan . . . Instead

- 1. Turn off the element.**
- 2. Smother the fire with a tightly fitting pan lid, baking soda or an extinguisher.**

YOUR COUNTER UNIT

IMPORTANT: The model and serial number of your cooktop can be found on a tag under the lift-up cooktop.

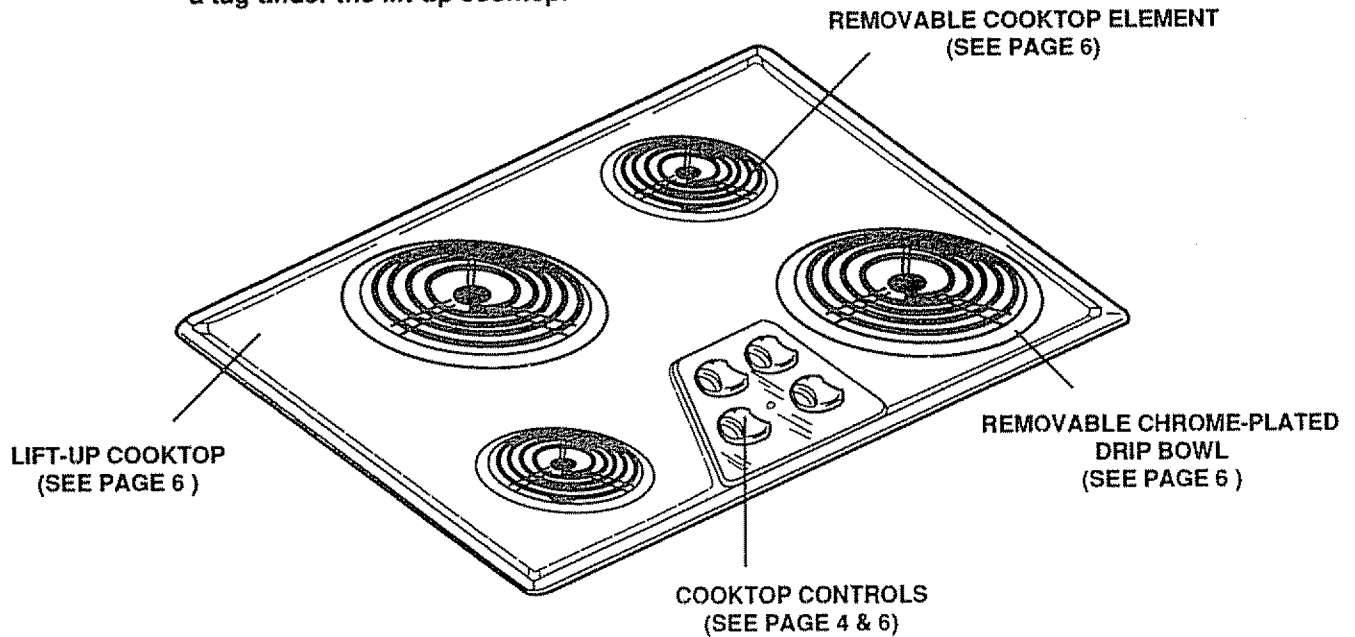

TO START THINGS COOKING Cooktop Cooking

The sign near each cooktop control knob shows which element is turned on by that knob.

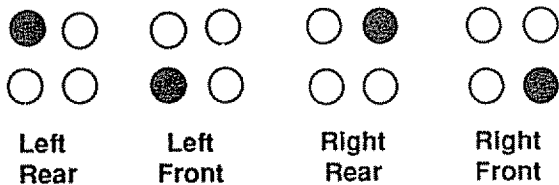

To operate cooktop controls:

1. Push to turn.
2. Set on or between marks for desired heat.

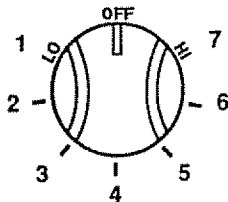

For best cooktop results and energy efficient operation, you should use pans that:

- A. Have flat bottoms and straight sides.
- B. Have light handles that do not tilt pans.
- C. Are about the same size as the element.

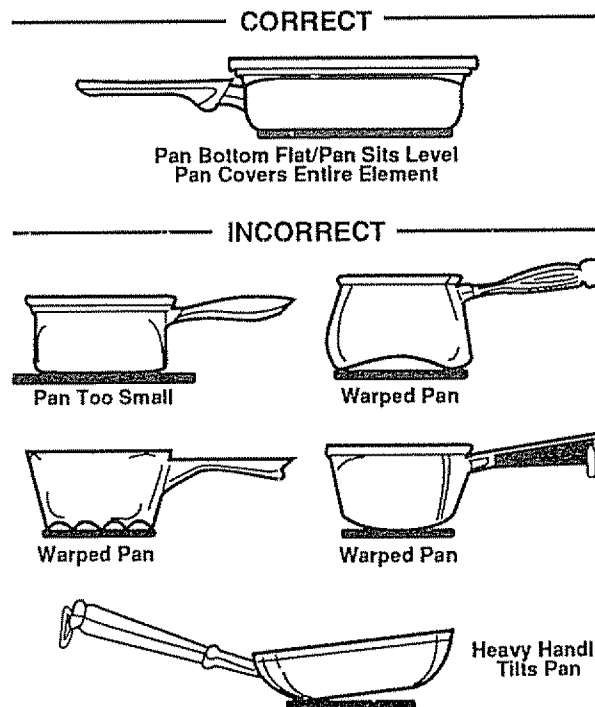

Never line the bowls below cooktop elements with aluminum foil. Foil can prevent normal heat flow and damage the unit.

CLEANING CHART

Warm water, a mild detergent, and a soft cloth are safe to use on all cleanable parts of your counter unit. Do not use metal scouring pads except where recommended.

PART	CLEANING MATERIALS	REMARKS
Control knobs	Mild soap and water	Pull off knobs. Wash gently but do not soak. Dry and return controls to unit.
Porcelain enameled cooktop	Cleansing powder, steel wool pad	If acids (such as tomatoes, lemon, etc.) should spill on the cooktop, use a dry paper towel or cloth to wipe up right away. When the surface has cooled, wash and rinse. For other spills, such as fat splatterings, wash with soap and water and then rinse. Polish with a dry cloth.
Chrome drip bowls Brown food stains Blue/gold heat stains	Detergent and water, plastic scouring pads, mild abrasive cleaners, soap-filled scouring pads, ammonia Metal polish	After each use, wash, rinse and dry to prevent difficult soils. If heavily soiled, place an ammonia-soaked paper towel on stains to loosen soil, then gently scrub with plastic scouring pad. These stains are caused by overheating, normally occur over a period of time, and usually are permanent. To minimize: <ol style="list-style-type: none"> 1. Avoid excessive use of the high heat setting. Use it to start cooking, then lower the heat setting to finish cooking. 2. Use flat bottom pans that do not extend more than two inches from the surface element. If large pans or canners are used, alternate the elements that are used.
Brushed chrome cooktop	Soap and water, Bon Ami® cleanser, chrome protectant	Wash and dry chrome cooktop after each use. For stubborn stains, use Bon Ami® and water. Rinse well. A chrome protectant helps to reduce spotting and fingerprinting.
Glass	Glass cleaner and paper towel. DO NOT use abrasive cleaners. If you need additional cleaning for spotting, wash with equal parts white vinegar and warm water; rinse well and dry.	If knobs are removed from a control panel, do not allow water to run down inside openings in the glass while cleaning. Remove stubborn soil with paste of baking soda and water.

REMOVABLE KNOBS

All control knobs may be removed for easy cleaning by pulling the knob straight off the stem. Be sure that the knob is in the OFF position before removal.

Hint: Slip a thin cloth (such as a handkerchief) or a piece of string under and around the knob edge and pull up.

Caution: Read these instructions carefully before replacing the knobs. Replacing the knobs improperly will damage the knobs and the spring clip on the stems. If this happens, the knobs will fit loosely.

To replace the knob:

1. Match the flat side of the "D" Shaft on the knob to the flat side of the stem and replace knob.

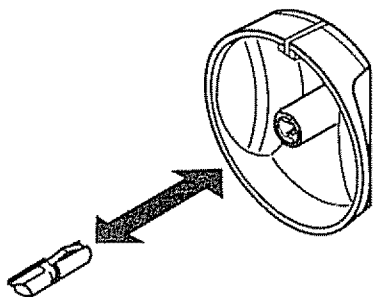

REMOVABLE COOKTOP UNITS

The cooktop elements can be unplugged and the bowls removed for cleaning.

Be sure all cooktop unit control knobs are turned off and elements are cool before you remove or replace a cooktop unit.

To remove:

1. Grasp element, tilt it upward slightly to clear the bowl, then pull away from the receptacle. The element will not sit level when replaced if it is forced too far upward when removed.
2. For models with porcelain enameled reflector bowls, remove the chrome trim ring.
3. Lift out the bowl.

Do not put the element into water. It cleans itself when heated during normal use.

To replace:

1. Replace the bowl. Be sure the receptacle is showing in the bowl opening.
2. For models with porcelain enameled reflector bowls, replace chrome trim ring.
3. Slide the plug of the element firmly into the receptacle and lower the element into place.

IMPORTANT: Never operate a cooktop element without the bowl in place. This can cause scorching of the cooktop, burning of wiring insulation and loss of energy.

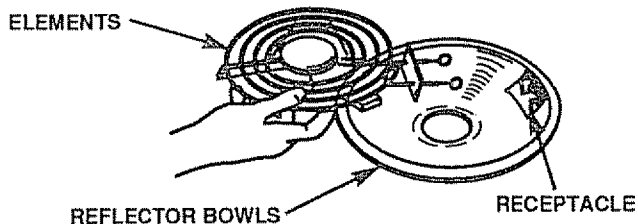

CAUTION: Do not pull element up more than 1/2" or damage to the receptacle will occur.

LIFT-UP COOKTOP

The cooktop lifts up so the cooktop and the area underneath (burner box bottom) can be cleaned.

Remove four surface units as described above.

To raise the cooktop:

1. Remove knobs.
2. Grasp at the front and lift up.
3. Raise the support rod into place to hold the cooktop while cleaning.

To lower the cooktop:

1. Carefully replace the support rod and lower the cooktop. Press into place. Make sure the strikes fit in the catches to fasten the cooktop.
2. Replace four surface units.
3. Replace knobs.

Be sure to secure cooktop support rod in the maintop strike bracket.

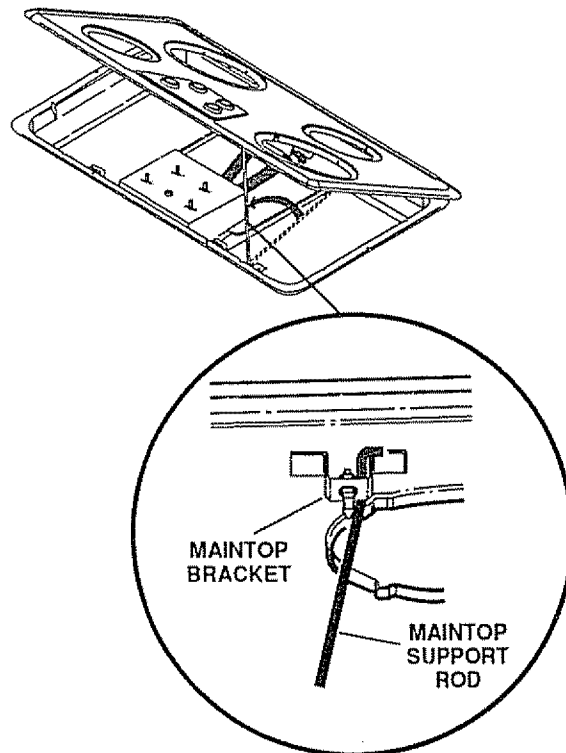

BEFORE CALLING FOR SERVICE

Save time and money - Check this list before you call for service.

To eliminate unnecessary service calls, first, read all the instructions in this manual carefully. Then, if you have a problem, always check this list of common problems and possible solutions before you call for service.

If you do have a problem you cannot fix yourself, call your nearest Sears Store or Service Center for help. When calling, have this manual and your Repair Parts List handy with the model, serial number and purchase date.

Customer 1-800 numbers are on page 8.

PROBLEM	POSSIBLE CAUSE	DON'T CALL FOR SERVICE UNTIL YOU CHECK
<ul style="list-style-type: none"> • Cooktop elements do not work 	<ul style="list-style-type: none"> • No power to unit • Improper operation of control • Surface unit not replaced correctly • Surface element needs replacing 	<ul style="list-style-type: none"> • Check household fuse or circuit breaker. • Be sure knob is pushed in while turning. • When surface unit is cool, check to see if drip pans are set securely in countertop and unit is plugged in correctly. • Unplug the element which will not heat. Plug in another element of the same size in its place. If the second element heats, replace the first element. If the second element does not heat, call for service.
<ul style="list-style-type: none"> • Heavily soiled or stained chrome cooktop cannot be satisfactorily cleaned 	<ul style="list-style-type: none"> • Spills were not wiped up promptly 	<ul style="list-style-type: none"> • See the Cleaning Tips for cleaning instructions.

For the repair or replacement parts you need

Call 7 am - 7 pm, 7 days a week

1-800-366-PART

(1-800-366-7278)

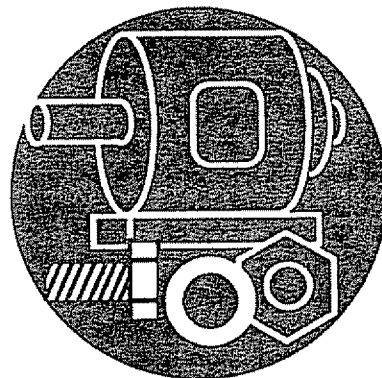

For in-home major brand repair service

Call 24 hours a day, 7 days a week

1-800-4-REPAIR

(1-800-473-7247)

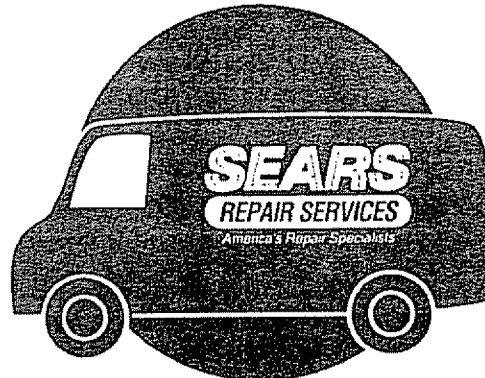

For the location of a
Sears Repair Service Center in your area

Call 24 hours a day, 7 days a week

1-800-488-1222

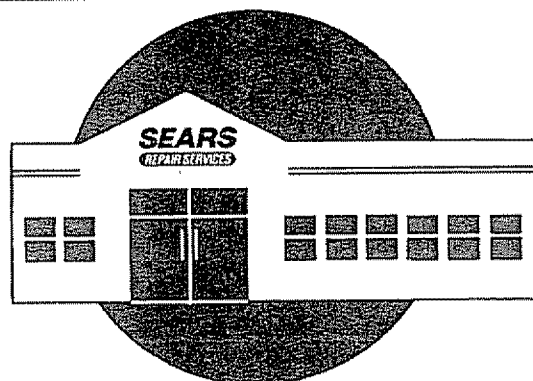

For information on purchasing a Sears
Maintenance Agreement or to inquire
about an existing Agreement

call 9 am - 5 pm, Monday-Saturday

1-800-827-6655

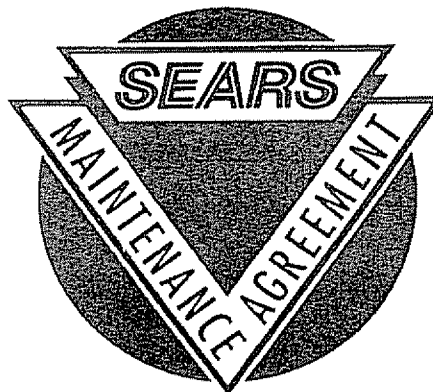

SEARS
REPAIR SERVICES

America's Repair Specialists

NOTES

KENMORE ELECTRIC COUNTER UNIT WARRANTY

Dear Customer:

Our constant efforts are directed toward making sure your new Kenmore Counter Unit will arrive at your home in perfect condition and will give you proper performance. As part of these efforts, we feel it is our responsibility to provide you with this warranty for your range.



FULL ONE YEAR WARRANTY ON THE FUNCTIONING OF ALL PARTS EXCEPT GLASS PARTS

If, within one year from the date of installation, any part, other than a glass part, fails to function properly due to a defect in material or workmanship, Sears will repair or replace it, free of charge.

FULL 30-DAY WARRANTY ON GLASS PARTS AND FINISH OF PORCELAIN ENAMEL, PAINTED OR BRIGHT METAL FINISHED PARTS

If, within 30 days from the date of installation, any glass part or the finish on any porcelain enamel, painted or bright metal part is defective in material or workmanship, Sears will replace the part, free of charge.

FULL 90-DAY WARRANTY ON MECHANICAL ADJUSTMENTS

For 90 days from the date of installation, Sears will provide, free of charge, any mechanical adjustments necessary for proper operation of the range, except for normal maintenance.

If the unit is subjected to other than private family use, the above warranty coverage is effective for only 90 days.

WARRANTY SERVICE IS AVAILABLE BY CONTACTING THE NEAREST SEARS SERVICE CENTER/DEPARTMENT IN THE UNITED STATES

This warranty applies only while this product is in use in the United States. This warranty gives you specific legal rights, and you may also have other rights which vary from state to state.

SEARS, ROEBUCK and CO.
 Dept. 720PSO
 3333 Beverly Road
 Hoffman Estates, IL 60179

WE SERVICE WHAT WE SELL

"We Service What We Sell" is our assurance to you that you can depend on Sears for service because Sears service is nationwide.

Your Kenmore Counter Unit has added value when you consider that Sears has a service unit near you staffed by Sears trained technicians. . . professional technicians specifically trained on Sears appliances, having the parts, tools and equipment to ensure that we meet our pledge to you — "We Service What We Sell!"

TO FURTHER ADD TO THE VALUE OF YOUR RANGE, BUY A SEARS MAINTENANCE AGREEMENT.

Kenmore Counter Units are designed, manufactured and tested for years of dependable operation. Yet, any modern appliance may require service from time to time. The Sears Warranty plus the Sears Maintenance Agreement provides protection from unexpected repair bills and assures you of enjoying maximum range efficiency. Here's a comparative warranty and Maintenance Agreement chart showing you the benefits of a Sears Range Maintenance Agreement.

Years of Ownership Coverage		1st Year	2nd Year	3rd Year
1	Replacement of Defective Parts other than Porcelain or Glass	W	MA	MA
2	Mechanical Adjustment	90 DAYS W	MA	MA
3	Porcelain and Glass Parts	30 DAYS W	MA	MA
4	Annual Preventive Maintenance Check at your request	MA	MA	MA

W - Warranty MA - Maintenance Agreement

CONTACT YOUR SEARS SALESPERSON OR LOCAL SEARS SERVICE CENTER TODAY AND PURCHASE A SEARS MAINTENANCE AGREEMENT.

Kenmore® America's Best Selling Appliance Brand
 Sold by SEARS, ROEBUCK AND CO., Hoffman Estates, IL 60179