

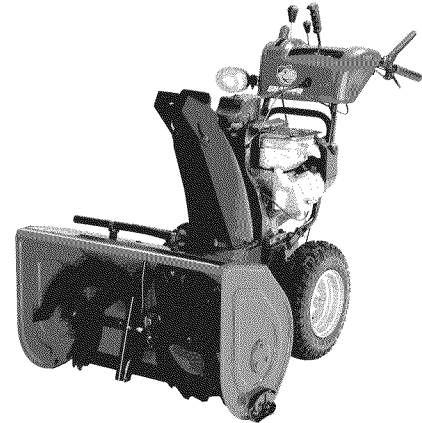

OPERATOR'S MANUAL

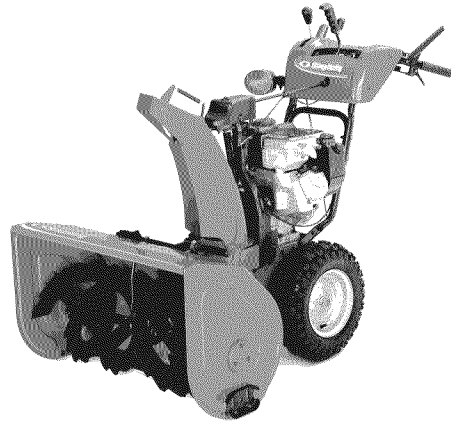

Large Frame Snowthrowers

8526 Models

| Mfg. No. | Description |
|----------|---------------------------------|
| 1694984 | L8526E, 8.5HP Snowthrower |
| 1695082 | L8526EX, 8.5HP Snowthrower (CE) |
| 1694993 | 85268E, 8.5HP Snowthrower |
| 1695093 | E85268E, 8.5HP Snowthrower (CE) |

9528 Models

| Mfg. No. | Description |
|----------|---------------------------------|
| 1694985 | L9528E, 9.5HP Snowthrower |
| 1695083 | L9528EX, 9.5HP Snowthrower (CE) |
| 1694994 | 95288E, 9.5HP Snowthrower |
| 1695094 | E95288E, 9.5HP Snowthrower (CE) |

10530 Models

| Mfg. No. | Description |
|----------|-----------------------------------|
| 1694986 | L10530E, 10.5HP Snowthrower |
| 1695084 | L10530EX, 10.5HP Snowthrower (CE) |
| 1694995 | 105308E, 10.5HP Snowthrower |
| 1695095 | E105308E, 10.5HP Snowthrower (CE) |

11532 Models

| Mfg. No. | Description |
|----------|-----------------------------------|
| 1694987 | L11532E, 11.5HP Snowthrower |
| 1694996 | 115328E, 11.5HP Snowthrower |
| 1695096 | E115328E, 11.5HP Snowthrower (CE) |

Table of Contents

CONTENTS:

Safety Rules & Information

| | |
|--|---|
| General | 2 |
| Training | 4 |
| Preparation | 4 |
| Operation | 4 |
| Children | 5 |
| Clearing a Clogged Discharge Chute | 5 |
| Service, Maintenance and Storage | 5 |
| Emissions | 3 |
| Decals | 6 |
| Safety Icons | 8 |

Identification Numbers.....9

Features, Controls, & Operation

| | |
|------------------------|----|
| Control Locations..... | 10 |
|------------------------|----|

General Operation

| | |
|--|----|
| Checks Before Each Start-Up | 12 |
| Starting Controls..... | 13 |
| Starting the Engine..... | 14 |
| Operating The Snowthrower..... | 14 |
| Clearing a Clogged Discharge Chute | 14 |
| Ground Speed Selector..... | 15 |
| Engine Speed..... | 15 |
| Deflector | 15 |
| Scraper Bar & Skid Shoes..... | 15 |
| Easy-Turn and Traction Drive Lock..... | 16 |
| After Each Use | 17 |
| Storage | 17 |

Regular Maintenance

| | |
|--|----|
| Schedule..... | 18 |
| Checking Tire Pressure | 18 |
| Auger Gear Case Lubrication | 18 |
| Lubrication | 19 |
| Check / Lubricate Free-Hand Linkage | 20 |
| Lubricate the Auger Shaft & Assembly | 20 |

Troubleshooting, Adjustments, & Service

| | |
|------------------------------------|----|
| Troubleshooting | 22 |
| Speed Selector Adjustment | 24 |
| Auger Drive Cable Adjustment | 24 |
| Traction Drive Adjustment..... | 25 |
| Easy Turn Cable Adjustment | 26 |
| Belt Adjustment | 26 |
| Shear Pin Replacement..... | 27 |
| Belt Guide Adjustment..... | 27 |
| Belt Replacement | 28 |

Specifications.....31

Replacement Parts & Accessories 32

WARNING

You must read, understand and comply with all safety and operating instructions in this manual before attempting to set-up and operate your snowthrower.

Failure to comply with all safety and operating instructions can result in loss of machine control, serious personal injury to you and /or bystanders, and risk of equipment and property damage. The triangle in the text signifies important cautions or warnings which must be followed.

WARNING

Engine exhaust from this product contains chemicals known, in certain quantities, to cause cancer, birth defects, or other reproductive harm.



Operating Safety

Congratulations on purchasing a superior-quality piece of lawn and garden equipment. Our products are designed and manufactured to meet or exceed all industry standards for safety.

Power equipment is only as safe as the operator. If it is misused, or not properly maintained, it can be dangerous! Remember, you are responsible for your safety and that of those around you.

Use common sense, and think through what you are doing. If you are not sure that the task you are about to perform can be safely done with the equipment you have chosen, ask a professional: contact your local authorized dealer.

Read the Manual

The operator's manual contains important safety information you need to be aware of BEFORE you operate your unit as well as DURING operation.

Safe operating techniques, an explanation of the product's features and controls, and maintenance information is included to help you get the most out of your equipment investment.

Be sure to completely read the Safety Rules and Information found on the following pages. Also completely read the Operation section.

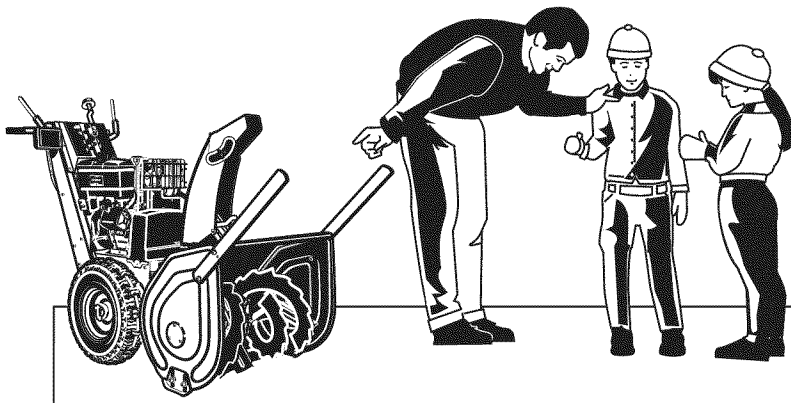

Children

Tragic accidents can occur with children. Do not allow them anywhere near the area of operation. Children are often attracted to the unit and snowthrowing activity. Never assume that children will remain where you last saw them. If there is a risk that children may enter the area where you are operating the unit, have another responsible adult watch them.

DO NOT ALLOW CHILDREN TO OPERATE THIS UNIT! This encourages them to come near the unit in the future while it is running, and they could be seriously hurt. They may then approach the unit when you are not expecting it, and you may run over them.

Moving Parts

This equipment has many moving parts that can injure you or someone else. However, if you are standing in the operator's position, and follow all the rules in this book, the unit is safe to operate.

The auger and impeller have spinning parts that can amputate hands and feet. Do not allow anyone near the equipment while it is running! DO NOT clear the discharge chute by hand. If the chute becomes plugged, stop the engine, wait for all moving parts to stop, and clear the blockage with a clean-out tool or piece of wood.

To help you, the operator, use this equipment safely, it is equipped with an operator-present safety system. Do NOT attempt to alter or bypass the system. See your dealer immediately if the system does not pass all the safety interlock system tests found in this manual.

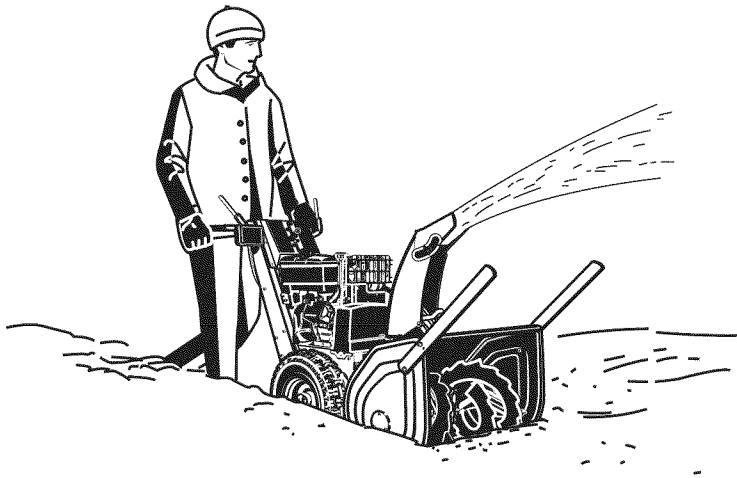

Thrown Objects

This unit has a spinning auger and impeller. They pick up and throw snow and ice. Thrown debris could seriously injure a bystander. ALWAYS direct the discharge chute away from bystanders and property that could be damaged by flying debris. Be sure to clean up the area to be cleared BEFORE you start.

Do not allow anyone in the area while the unit is running! If someone does enter the area, shut the unit off immediately until they leave.

Fuel and Maintenance

Gasoline is extremely flammable. Its vapors are also extremely flammable and can travel to distant ignition sources. Gasoline must only be used as a fuel, not as a solvent or cleaner. It should never be stored any place where its vapors can build up or travel to an ignition source like a pilot light. Fuel belongs in an approved, plastic, sealed gas can, or in the snowthrower fuel tank with the cap securely closed. Spilled fuel needs to be cleaned up immediately.

Proper maintenance is critical to the safety and performance of your unit. Be sure to perform the maintenance procedures listed in this manual, especially periodically testing the safety system.

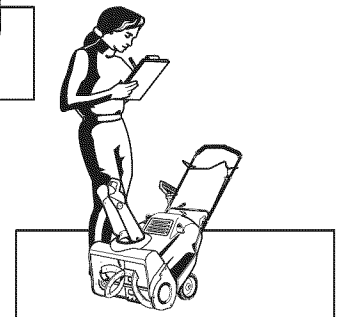
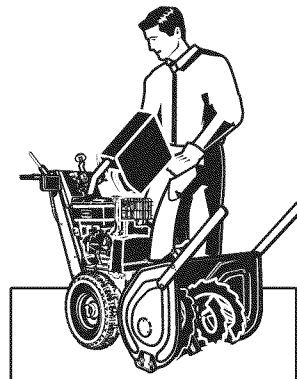

Safety Rules & Information



This machine is capable to amputating hands and feet and throwing objects. Read these safety rules and follow them closely. Failure to obey these rules could result in loss of control of unit, severe personal injury or death to you, or bystanders, or damage to property or equipment. The triangle  in text signifies important cautions or warnings which must be followed.

TRAINING

1. Read, understand, and follow all instructions on the machine and in the manuals before operating this unit. Be thoroughly familiar with the controls and the proper use of the equipment. Know how to stop the unit and disengage the controls quickly.
2. Never allow children to operate the equipment. Never allow adults to operate the equipment without proper instruction.
3. Keep the area of operation clear of all persons, particularly small children and pets.
4. Exercise caution to avoid slipping or falling especially when operating in reverse.

PREPARATION

1. Thoroughly inspect the area where the equipment is to be used and remove all doormat, sleds, boards, wires, and other foreign objects.
2. Disengage all clutches and shift into neutral before starting engine (motor).
3. Do not operate the equipment without wearing adequate winter outer garments. Wear footwear that will improve footing on slippery surfaces. Avoid loose fitting clothing that can get caught in moving parts.
4. Handle fuel with care; it is highly flammable.
 - (a) Use an approved fuel container.
 - (b) Never add fuel to a running engine or hot engine.
 - (c) Fill fuel tank outdoors with extreme care. Never fill fuel tank indoors. Replace fuel cap securely and wipe up spilled fuel.
 - (d) Never fill containers inside a vehicle or on a truck or trailer bed with a plastic liner. Always place containers on the ground, away from your vehicle, before filling.
 - (e) When practical, remove gas-powered equipment from the truck or trailer and refuel it on the ground. If this is not possible, then refuel such on a trailer with a portable container, rather than from a gasoline dispenser nozzle.
 - (f) Keep nozzle in contact with the rim of the fuel tank or container opening at all times, until refueling is complete. Do not use a nozzle lock-open device.
 - (g) Replace gasoline cap securely and wipe up spilled fuel.
 - (h) If fuel is spilled on clothing, change clothing immediately.
5. Use extension cords and receptacles as specified by the manufacturer for all units with electric drive motors or electric starting motors.
6. Adjust the collector housing height to clear gravel or crushed rock surfaces.
7. Never attempt to make any adjustments while the engine (motor) is running (except when specifically recommended by the manufacturer).
8. Let engine (motor) and machine adjust to outdoor temperatures before starting to clear snow.
9. Always wear safety glasses or eye shields during operation or while performing an adjustment or repair to protect eye from foreign objects that may be thrown from the machine.

OPERATION

1. Do not put hands or feet near or under rotating parts. Keep clear of the discharge opening at all times.
2. Exercise extreme caution when operating on or crossing gravel drives, walks, or roads. Stay alert for hidden hazards or traffic.
3. After striking a foreign object, stop the engine (motor), remove the wire from the spark plug, disconnect the cord on electric motors, thoroughly inspect the snowthrower for any damage, and repair the damage before restarting and operating the snowthrower.
4. If the unit should start to vibrate abnormally, stop the engine (motor) and check immediately for the cause. Vibration is generally a warning of trouble.
5. Stop the engine (motor) whenever you leave the operating position, before unclogging the collector/impeller housing or discharge guide, and when making any repairs, adjustments, or inspections.
6. When cleaning, repairing, or inspecting make certain the collector/impeller and all moving parts have stopped. Disconnect the spark plug wire and keep the wire away from the plug to prevent accidental starting.
7. Do not run the engine indoors except for starting the engine or for transporting the snowthrower in or out of the building. Open the outside doors; exhaust fumes are dangerous.
8. Exercise extreme caution when operating on slopes. Do not attempt to clear steep slopes.
9. Never operate the snowthrower without proper guards plates, or other safety protective devices in place and working.
10. Never direct the discharge toward people or areas where property damage can occur. Keep children and others away.
11. Do not overload the machine capacity by attempting to clear snow at too fast a rate.
12. Never operate the machine at high transport speeds on slippery surfaces. Look behind and use care when operating in reverse.
13. Disengage power to the collector/impeller when snowthrower is transported or not in use.
14. Use only attachments and accessories approved by the manufacturer of the snowthrower (such as wheel weights, counterweights, or cabs).
15. Never operate the snowthrower without good visibility or light. Always be sure of your footing, and keep a firm hold on the handles. Walk, never run.
16. Never touch a hot engine or muffler.
17. Never operate the snowthrower near glass enclosures, automobiles, window wells, drop-offs, and the like without proper adjustment of the discharge angle.
18. Never direct discharge at bystanders or allow anyone in front of the unit.
19. Never leave a running unit unattended. Always disengage the auger and traction controls, stop engine, and remove keys.
20. Do not operate the unit while under the influence of alcohol or drugs.

21. Keep in mind the operator is responsible for accidents occurring to other people or property.
22. Data indicates that operators, age 60 years and above, are involved in a large percentage of power equipment-related injuries. These operators should evaluate their ability to operate the unit safely enough to protect themselves and others from injury.
23. DO NOT wear long scarves or loose clothing that could become entangled in moving parts.
24. Snow can hide obstacles. Make sure to remove all obstacles from the area to be cleared.
8. Always follow the engine manual instructions for storage preparations before storing the unit for both short and long term periods.
9. Always follow the engine manual instructions for proper start-up procedures when returning the unit to service.
10. Maintain or replace safety and instruction labels as necessary.
11. Keep nuts and bolts tight and keep equipment in good condition.
12. Never tamper with safety devices. Check their proper operation regularly and make necessary repairs if they are not functioning properly.
13. Components are subject to wear, damage, and deterioration. Frequently check components and replace with manufacturer's recommended parts, when necessary.
14. Check control operation frequently. Adjust and service as required.
15. Use only factory authorized replacement parts when making repairs.
16. Always comply with factory specifications on all settings and adjustments.
17. Only authorized service locations should be utilized for major service and repair requirements.
18. Never attempt to make major repairs on this unit unless you have been properly trained. Improper service procedures can result in hazardous operation, equipment damage and voiding of manufacturer's warranty.
19. Check shear bolts and other bolts at frequent intervals for proper tightness to be sure the equipment is in safe working condition.

CHILDREN

Tragic accidents can occur if the operator is not alert to the presence of children. Children are often attracted to the unit and the operating activity. Never assume that children will remain where you last saw them.

1. Keep children out of the area and under the watchful care of another responsible adult.
2. Be alert and turn unit off if children enter the area.
3. Never allow children to operate the unit.
4. Use extra care when approaching blind corners, shrubs, trees, or other objects that may obscure vision.

CLEARING A CLOGGED DISCHARGE CHUTE

Hand contact with the rotating impeller inside the discharge chute is the most common cause of injury associated with snowthrowers. Never use your hand to clean out the discharge chute.

To clear the chute:

1. SHUT OFF THE ENGINE.
2. Wait 10 seconds to be sure the impeller blades have stopped rotating.
3. Always use a clean out tool, not your hands.

SERVICE, MAINTENANCE, AND STORAGE

1. Check shear bolts and other bolts at frequent intervals for proper tightness to be sure the equipment is in safe working condition.
2. Never store the machine with fuel in the fuel tank inside a building where ignition sources are present such as hot water and space heaters, or clothes dryers. Allow the engine to cool before storing in any enclosure.
3. Always refer to the operator's manual for important details if the snowthrower is to be stored for an extended period.
4. Maintain or replace safety and instruction labels as necessary.
5. Run the machine a few minutes after throwing snow to prevent freeze-up of the collector/impeller.
6. If fuel is spilled, do not attempt to start the engine but move the machine away from the area of spillage and avoid creating any source of ignition until fuel vapors have dissipated.
7. Always observe safe refueling and fuel handling practices when refueling the unit after transportation or storage.

EMISSIONS

1. Engine exhaust from this product contains chemicals known, in certain quantities, to cause cancer, birth defects, or other reproductive harm.
2. If available, look for the relevant Emissions Durability Period and Air Index information on the engine emissions label.

IGNITION SYSTEM

1. This spark ignition system complies with Canadian ICES-002.

Decals

DECALS

This unit has been designed and manufactured to provide you with the safety and reliability you would expect from an industry leader in outdoor power equipment.

Although reading this manual and safety instructions it contains will provide you with the necessary basic knowledge to operate this equipment safely and effectively, we have placed several safety labels on the unit to remind you of this important information while you are operating your unit.

All WARNING, CAUTION, and instructional messages on your unit should be carefully read and obeyed. Personal bodily injury can result when these instructions are not followed. The information is for your safety and it is important.

The safety decals below are on your unit.

If any of these decals are lost or damaged, replace them at once. See your local dealer for replacements.

These labels are easily applied and will act as a constant visual reminder to you, and others who may use the equipment, to follow the safety instructions necessary for safe, effective, operation.

NOTE: Engine operation and safety decals are supplied by the engine manufacturer.

NORTH AMERICAN MODEL DECALS

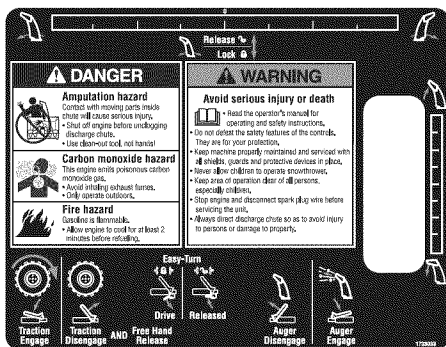

Part No. 1733033 - DANGER / WARNING Main Dash Decal, North American, w/ Easy Turn

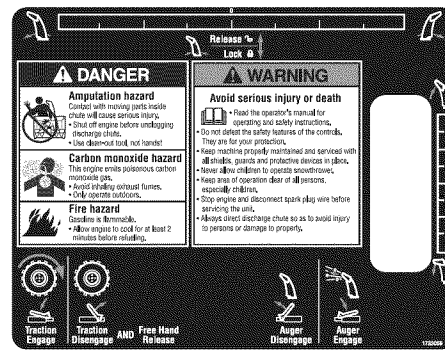

Part No. 1733056 - DANGER / WARNING Main Dash Decal, North American, w/o Easy Turn

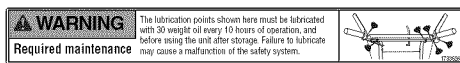

Part No. 1733526 Lubrication Decal



Part No. 1716532 Auger Danger Decal



Part No. 1733057 Discharge Chute Danger Decal



Part No. 728183 Important Over Adjustment

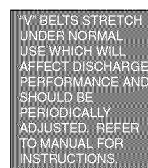

Part No. 725432 Belt Stretch & Adjust

ALL MODEL DECALS



**Part No. 1732618
Shift Decal**



**Part No. 1733443
Chute Release**

CE MODEL DECALS

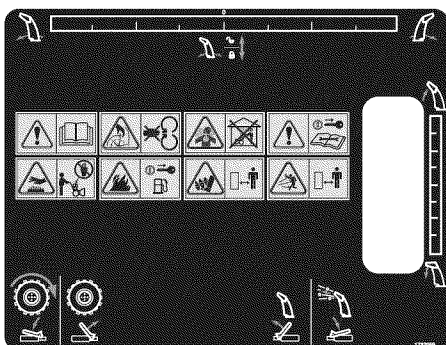

**Part No. 1733059 - DANGER / WARNING
Main Dash Decal, CE, w/o Easy Turn**



**Part No. 1733060 - DANGER / WARNING
Main Dash Decal, CE, w/ Easy Turn**



**Part No. 1727207
Discharge Chute
Danger Decal**



**Part No. 1727208
Auger Danger Decal**

Safety Icons

SAFETY ICONS

WARNING: READ OPERATOR'S MANUAL.

Read and understand the Operator's Manual before using this machine.

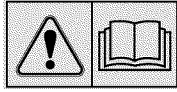

WARNING: DISMEMBERMENT.

This machine can amputate limbs. Keep bystanders and children away when engine is running.



DANGER: THROWN OBJECTS.

This machine is capable of throwing objects and debris. Keep bystanders away.

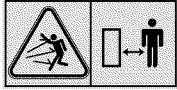

DANGER: DISMEMBERMENT.

The auger can amputate limbs. Keep hands and feet away from auger and rotating parts.

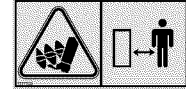

WARNING: REMOVE KEY BEFORE SERVICING.

Remove the key, disconnect spark plug wire, and consult technical literature before performing repairs or maintenance.

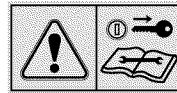

DANGER: DISMEMBERMENT.

The impeller can amputate limbs. Stop the engine, remove the key, and disconnect spark plug wire before clearing the discharge chute or performing service work. Keep hands and feet away from impeller and rotating parts.

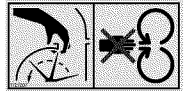



**North American /
CE Models**

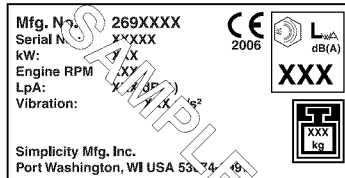

**CE Models
(Only)**

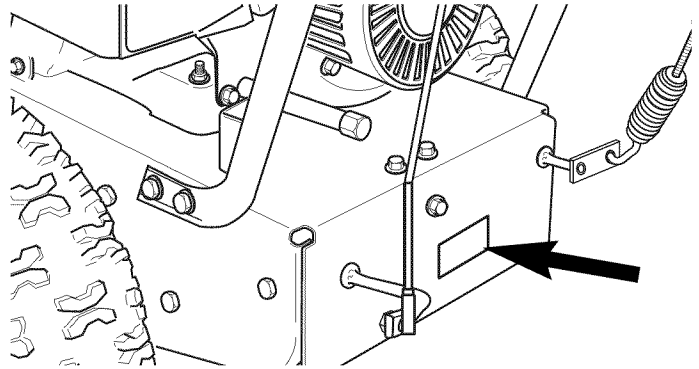

Identification Numbers

When contacting your authorized dealer for replacement parts, service, or information you **MUST** have these numbers.

Record your model name/number, manufacturer's identification numbers, and engine serial numbers in the space provided for easy access. These numbers can be found in the locations shown.

NOTE: For location of engine identification numbers, refer to the engine owner's manual.

CE Models: Place the extra copy of the identification tag in the manual

| PRODUCT REFERENCE DATA | |
|-------------------------------|---------------------------|
| Model Description Name/Number | |
| Unit MFG Number | Unit SERIAL Number |
| | |
| Dealer Name | Date Purchased |
| ENGINE REFERENCE DATA | |
| Engine Make | Engine Model |
| Engine Type/Spec | Engine Code/Serial Number |

CE IDENTIFICATION TAG MARKINGS

- A. Manufacturer's Identification Number
- B. Manufacturer's Serial Number
- C. Power Rating in Kilowatts
- D. Maximum Engine Speed in Rotations per Minute
- E. Manufacturer's Address
- F. Year of Manufacture
- G. CE Compliance Logo
- H. Mass of Unit in Kilograms
- I. Sound Power in Decibels
- J. Sound Pressure at Operator's Position in Decibels
- K. Vibration

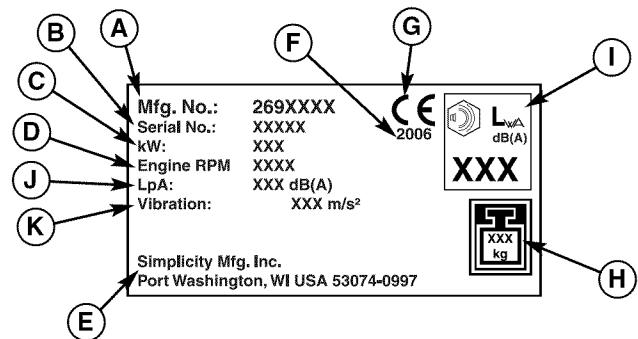

This unit complies with ISO 8437, European Machinery Directive 98/37/EC, and European EMC Directive 89/336/EC.

*CE Models:
Place copy of
Identification Tag here.*

Features, Controls, & Operation

Please take a moment and familiarize yourself with the name, location, and function of these controls so that you will better understand the safety and operating instructions provided in this manual.

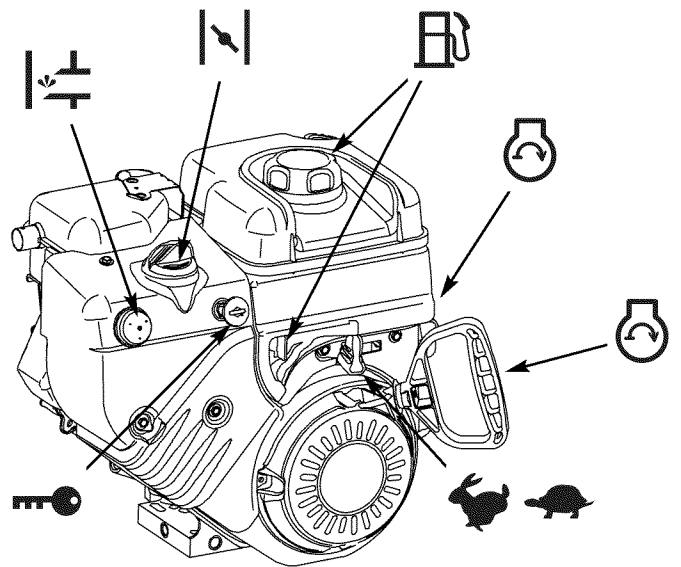
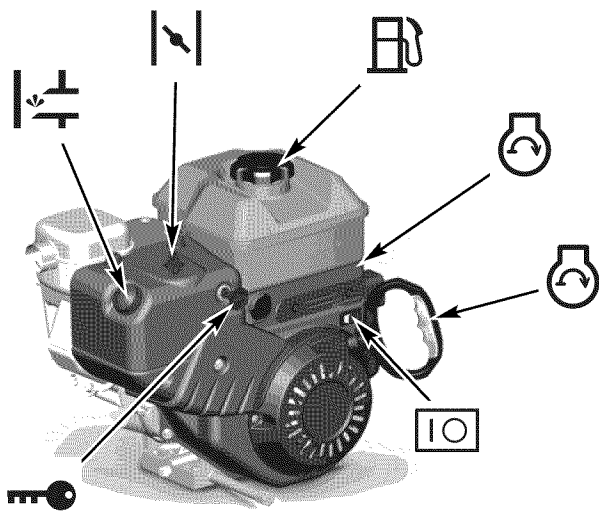
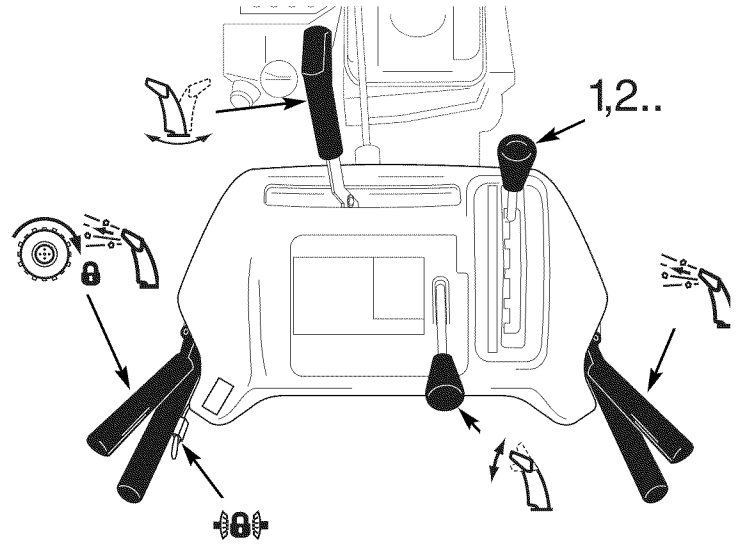
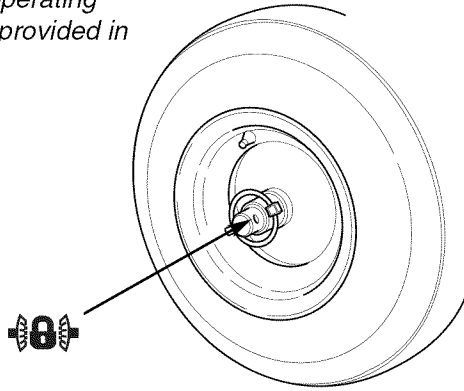

CONTROL LOCATIONS

The information below briefly describes the function of individual controls. Starting, stopping, and driving require the combined use of several controls applied in specific sequences. To learn what combination and sequence of controls to use for various tasks see the OPERATION section.

1,2.. Speed Selector

Selects forward speeds 1-6 and reverse speeds 1-2. No neutral position or gate is required, since the traction drive design automatically provides "neutral" (no forward or reverse movement), whenever the Drive Control is released.

Traction Control / Free Hand™ Lock

Engages traction drive to wheels when depressed. Also locks auger control when depressed simultaneously. Releasing the traction control lever releases the Free Hand™ auger control lock and stops the drive wheels and auger.



Auger Control

Engages the auger/impeller when depressed. Releasing the control stops the auger/impeller.



Chute Direction Control

Push the lever forward to unlock the rotator control. Moving the lever to the left will turn the spout to the left side and moving the lever to the right will rotate the spout to the right side. Releasing the lever locks the spout in position.



Remote Deflector Control

Chute Deflector: Locks chute deflector in desired position. Tilting the chute deflector UP provides a higher stream and greater distance, while tilting the deflector DOWN provides a lower stream and less distance.



Easy Turn™ Control

Easy Turn Control: Engaging the Easy Turn™ lever releases the left wheel to allow easy turning in tight areas. Releasing the control automatically engages both drive wheels for full traction.

Traction Lock Pins: (8.5HP Models Only) The right traction wheel can be completely released using the locking pin (see Figure 7). This allows the unit to be easily moved with the engine off.



Stop Switch (Power Built Models Only)

Turn the the switch to the ON position to operate the engine. Turn the switch to the OFF position to stop the engine.



Starter

Electric Start: Depressing the starter button activates the electric starter. The electric start button operates on 120 Volts AC, which is provided by connection to the extension cord provided. Connect this extension cord ONLY to a properly grounded 3 prong electrical outlet.

Recoil Starter (All Models): Pulling the recoil handle cranks the engine.



Fuel

Fuel tank filler cap (see illustration). Note: The fuel shut off valve is located under the fuel tank or on the front of the engine. Close the valve when the snowthrower is not in use. Open the valve before starting.



Primer Button

When pressed, the primer button provides initial fuel to help start a cold engine. Normally, pressing the primer button twice will provide enough fuel to start a cold engine.



Throttle Lever (Intek Models Only)

Controls engine speed. Move toward the hare icon for faster engine speed, move toward the turtle icon for slower engine speed. Move the throttle all the way to STOP to stop the engine. Set throttle to FAST (hare icon) for operation.



Engine Key

The engine key prevents the engine from being started. The key must be fully inserted into the key slot for the unit to start. The key can also used to stop the engine by pulling the key out of the key slot.



Choke Knob

The choke knob adjusts the air/fuel mixture, and is used to help start a cold engine by providing a richer mixture. Once the engine is warm and running smoothly, the choke knob should be set to the off position to provide a normal air/fuel mix.



Headlight (Select Models, Not Pictured)

The headlight is on at all times when the engine is running.

Operation

GENERAL OPERATION

CHECKS BEFORE EACH START-UP

1. Make sure all safety guards are in place and all nuts, bolts and clips are secure.
2. Check to make sure that the clean-out is attached to the auger housing. Do not operate the machine without the clean-out tool properly stored on the auger housing.
3. Check the engine oil level. See your engine owner's manual for procedure and specifications.
4. Check to make sure spark plug wire is attached and spark plug is tightened securely. If necessary, torque spark plug to 15 ft. lbs.
5. Check the fuel supply. Fill the tank no closer than 1/4 to 1/2 inch of top of tank to provide space for expansion. See your engine owner's manual for fuel recommendations.
6. Check the scraper bar to make sure it is set at the desired height. Adjust the skid shoes if necessary.
7. Check the drive control (B, Figure 2), and auger control (C) for proper operation. If adjustment is required, see the service section for procedures.
8. Check the chute direction control (D, Figure 2) for proper operation. The discharge chute should rotate freely in both directions. See the service section for adjustment procedures and troubleshooting.
9. Check the chute deflector (E, Figure 2) for proper operation. The deflector should pivot freely up and down.
10. Position the chute at the desired starting direction and set the deflector at the desired angle.
11. Check the speed selector (A, Figure 2) for smooth operation. The control must move freely into each speed position gate and remain in position when released. If the speed selector does not move freely into all forward and reverse speed positions, contact your local authorized dealer for assistance.

WARNING

This unit is a "two-stage" snowthrower.

The first stage is the auger, which feeds the snow back into the impeller housing. The second stage is the impeller, which throws the snow out the discharge chute. If bodily contact is made with the auger or impeller when they are rotating, severe personal injury will occur.

To avoid injury, keep others and yourself away from the auger and the discharge chute whenever the engine is running. Read and follow all of the safety rules and warnings in this manual.

DANGER

Do not clean out discharge chute with hands. Contact with moving parts inside chute will cause serious injury. Use clean out tool provided with machine. Use the following procedure to remove objects or clear the chute:

1. Stop the engine. Remove the key
2. Wait 10 seconds to be sure the auger/impeller blades have stopped rotating.
3. Always use the clean-out tool. DO NOT use your hands.

WARNING

For your safety, operation on slopes should be in an up and down direction only. If it becomes necessary to move across the face of a slope, use caution and do not blow snow. Be very careful when changing direction on a slope.

Proper winter footwear is recommended for the operator to help prevent slipping. Never attempt to clean snow from excessively steep slopes. The maximum slope for any operation is 17.7% (10°).

WARNING

Gasoline is highly flammable and must be handled with care. Never fill the tank when the engine is hot or running. Always move outdoors to fill the tank. Keep snowthrower and gasoline away from open flame or spark.

STARTING CONTROLS

See Figure 1 for the following instructions.

Electric Start

- A. Electric Start Button** - The Electric Start Button (A) activates an electric starter mounted to the engine, eliminating the need to pull the starter handle. The Electric Start Button operates on 120 Volts AC, which is provided by connection to the extension cord provided with units equipped with this feature. **Connect this extension cord ONLY to a properly grounded 3 prong electrical outlet.**

Manual Start

- B. Fuel Valve** - (Intek Models) The fuel valve (B) is located under the fuel tank. It is used to turn the fuel supply off for out-of-season storage.
- C. Starter Handle** - The starter handle (C) connects to a starter cord to manually start the engine. Pulling starter handle rapidly spins the engine crankshaft, cycles the engine, and generates the spark necessary for starting the engine.
- D. Primer Button** - When pressed, the primer button (D) provides initial fuel to help start a cold engine. Normally, pressing the primer button twice will provide enough fuel to start a cold engine.
- E. Throttle Lever** - (Intek Models) The throttle lever (E) controls the engine speed. For best overall performance, the throttle lever should be set to the **FAST** position. Use the **SLOW** position only for warming the engine, or to help prevent snow/ice freeze-up when shutting the unit down for the day.
- F. Engine Key** - The engine key (F) prevents the engine from being started by unauthorized individuals. The key must be fully inserted into the key slot for the unit to start. The key is also used to stop the engine by pulling the key out of the key slot.
- G. Choke Knob** - The choke knob (G) adjusts the air/fuel mixture, and is used to help start a cold engine by providing a richer mixture. Once the engine is warm and running smoothly, the choke knob should be set to the off position to provide a normal air/fuel mix.
- H. Stop Switch** - (Power Built Models) Switch to the ON position to operate the engine. Switch to the OFF position to stop the engine.

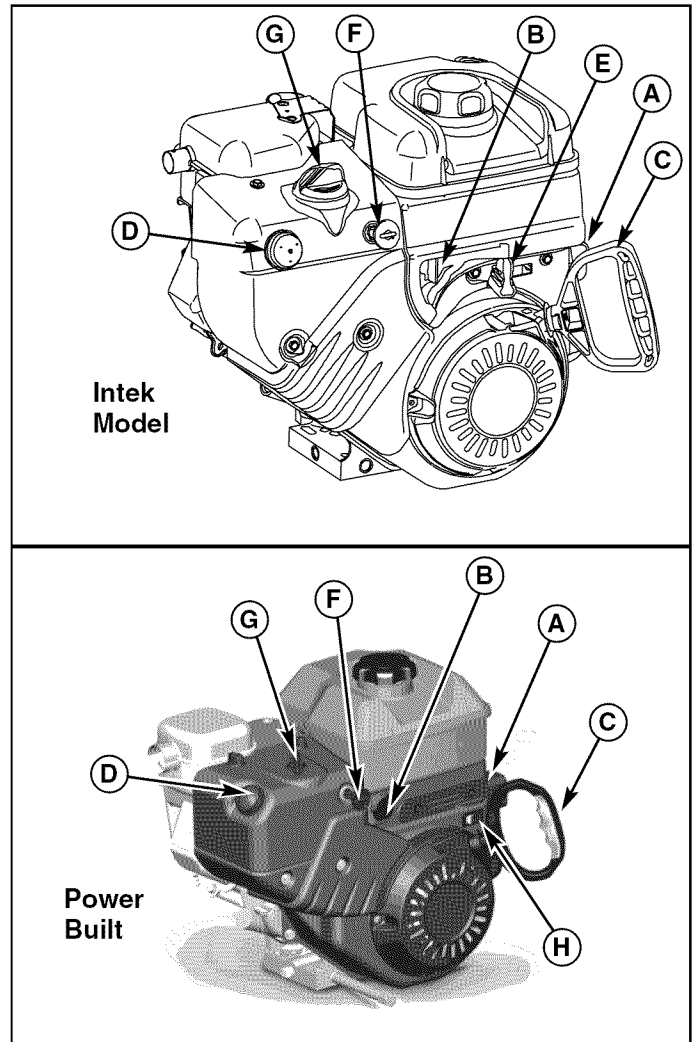

Figures 1. Engine Controls
A. Electric Start Button
B. Fuel Valve (Select Models)
C. Starter Handle
D. Primer Button
E. Throttle Lever (Intek Models Only)
F. Engine Key
G. Choke Knob
H. Stop Switch (Power Built Models)

Operation

STARTING THE ENGINE

1. Turn the fuel valve (B, Figure 1, Intek Models) to the ON position.
2. Switch the stop switch (H, Power Built models) to the on position.
3. Insert the engine key (F) into the engine key slot and push fully in to the RUN position.
4. Move the throttle lever (E) fully up to the FAST position.
5. Turn the choke knob (G) fully clockwise if engine is cold. (Do not choke a warm engine.)
6. Push the primer button (D) two times if engine is cold. (Do not prime a warm engine.)
7. **Engine Mounted Electric Start:** Press the starter button to crank the engine.

Manual Start: Pull starter handle (C) rapidly to start the engine. Do not allow the starter handle to snap back—let the starter rope rewind slowly—while keeping a firm grip on the starter handle.

8. As the engine starts and begins to operate evenly, turn the choke knob (G) slowly counter-clockwise to the OFF position, and set the Throttle Lever to SLOW. If the engine falters, turn the choke knob clockwise until the engine runs smoothly, and let it run briefly before returning the choke to the OFF position.

NOTE: Allow the engine to warm up at SLOW throttle for a few minutes before operating the snowthrower at full speed. The engine will not develop full power until it reaches operating temperature. After warming up, always operate at full throttle.

OPERATING THE SNOWTHROWER

1. Rotate the discharge chute to the desired direction.
2. Set the speed selector to the desired forward speed.
3. Fully press and hold the auger engage control (C, Figure 2) on the right-hand grip to begin auger rotation. Releasing the auger engage control will disengage the auger —**unless the Free-Hand™ Control has been activated (See step 5 below).**
4. Fully press and hold the traction & Free-Hand™ Control lever (B, Figure 2) on the left-hand grip to engage the traction drive and begin moving the snowthrower. To disengage the traction drive, completely release the lever.

5. When BOTH levers are depressed, the Free-Hand™ Control is activated. This allows Auger Engage Control to be released — **YET AUGER ROTATION WILL CONTINUE — until the Free-Hand™ Control is released.**
6. Select forward or reverse speeds as needed using the Speed Selector (A, Figure 2). Release both control levers before changing drive speeds.

CLEARING A CLOGGED DISCHARGE CHUTE

Hand contact with the rotating auger/impeller inside the discharge chute is the most common cause of injury associated with snowthrowers. **DO NOT** use your hand to clean out the discharge chute. To clear the chute:

1. Stop the engine. Remove the key
2. Wait 10 seconds to be sure the auger/impeller blades have stopped rotating.
3. Use the clean-out tool to remove clogs. **DO NOT** use your hands.

⚠ WARNING

When BOTH levers are depressed, the Free-Hand™ Control is activated. This allows Auger Engage Control to be released — YET AUGER ROTATION WILL CONTINUE — until the Free-Hand™ Control is released.

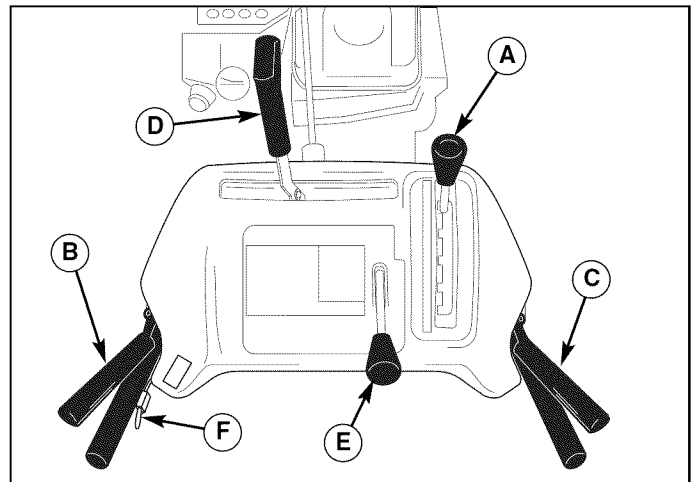

Figure 2. Controls (from operator's position)

- A. Speed Selector**
- B. Traction & Free-Hand™ Control**
- C. Auger Engage Control**
- D. Chute Rotator Control**
- E. Remote Deflector Control**
- F. Easy Turn Lever**

GROUND SPEED SELECTOR

Use the speed selector (A, Figure 2) to control the drive speed of the snowthrower. There are five forward speeds and two reverse speeds.

Use the lower speeds to blow deep or wet snow. Use the higher speeds to blow light snow or to drive the snowthrower without blowing snow.

To change speeds, release the auger control lever (B, Figure 2), then move the speed selector to the desired setting. Fully depress the control levers to resume.

ENGINE SPEED

Always run the snowthrower at full throttle.

DEFLECTOR

The distance of the discharged snow is mainly controlled by the position of the deflector. (Engine speed also affects distance of discharge.) The more the deflector is tilted UP, the farther snow will be thrown.

1. Push the remote deflector control (C) to the left to UNLOCK the control. Sliding the control forward (B) will put the deflector to the maximum throwing position (A). Sliding the control backwards to decrease the throwing distance.
2. Release the control to LOCK in place when the desired angle has been chosen.

SCRAPER BAR & SKID SHOES

On smooth surfaces such as concrete or asphalt, the scraper bar (A, Figure 4) should scrape the surface. On surfaces such as gravel, the scraper bar should be high enough so that it will not pick up gravel or debris.

The height of the scraper bar (A) is controlled by raising or lowering the skid shoes (B).

1. To raise the scraper bar height, rest the scraper bar (A) on a strip of wood equal in thickness to the desired height.
2. Make sure the scraper bar is parallel to the ground surface.
3. Loosen the skid shoe nuts (C) and let the skid shoes (B) drop to the surface.
4. Tighten the nuts (C), making sure the skid shoes are adjusted equally and are parallel to the surface.
5. To lower the height of the scraper bar, raise the skid shoes.
6. If the scraper bar becomes worn, it can be replaced by removing the hardware attaching it to the snowthrower.

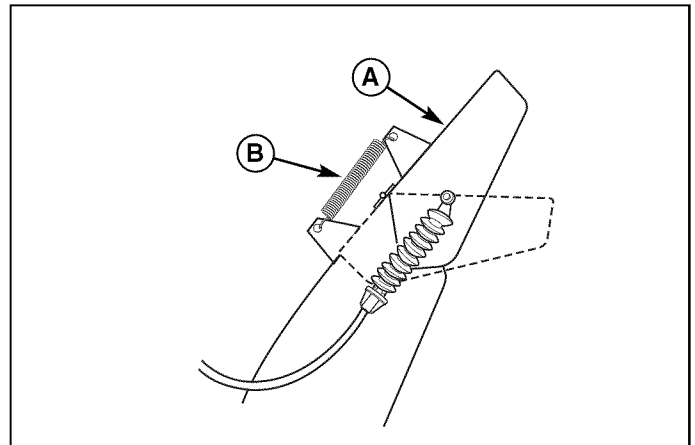

Figure 3. Remote Deflector Control
A. Maximum Throwing Position
B. Spring

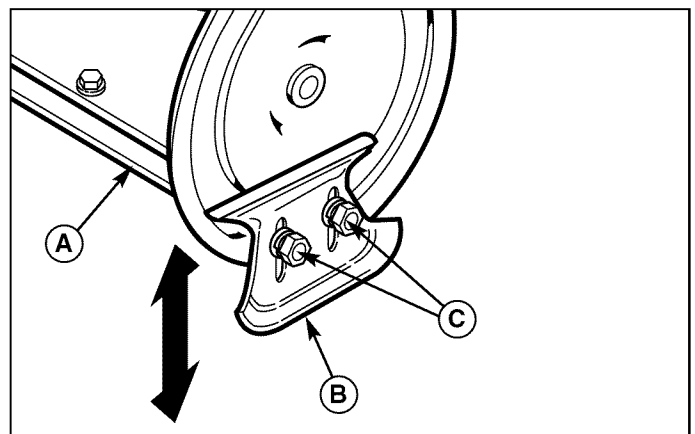

Figure 4. Skid Shoe Adjustment
A. Scraper Bar
B. Skid Shoe
C. Nuts

Operation

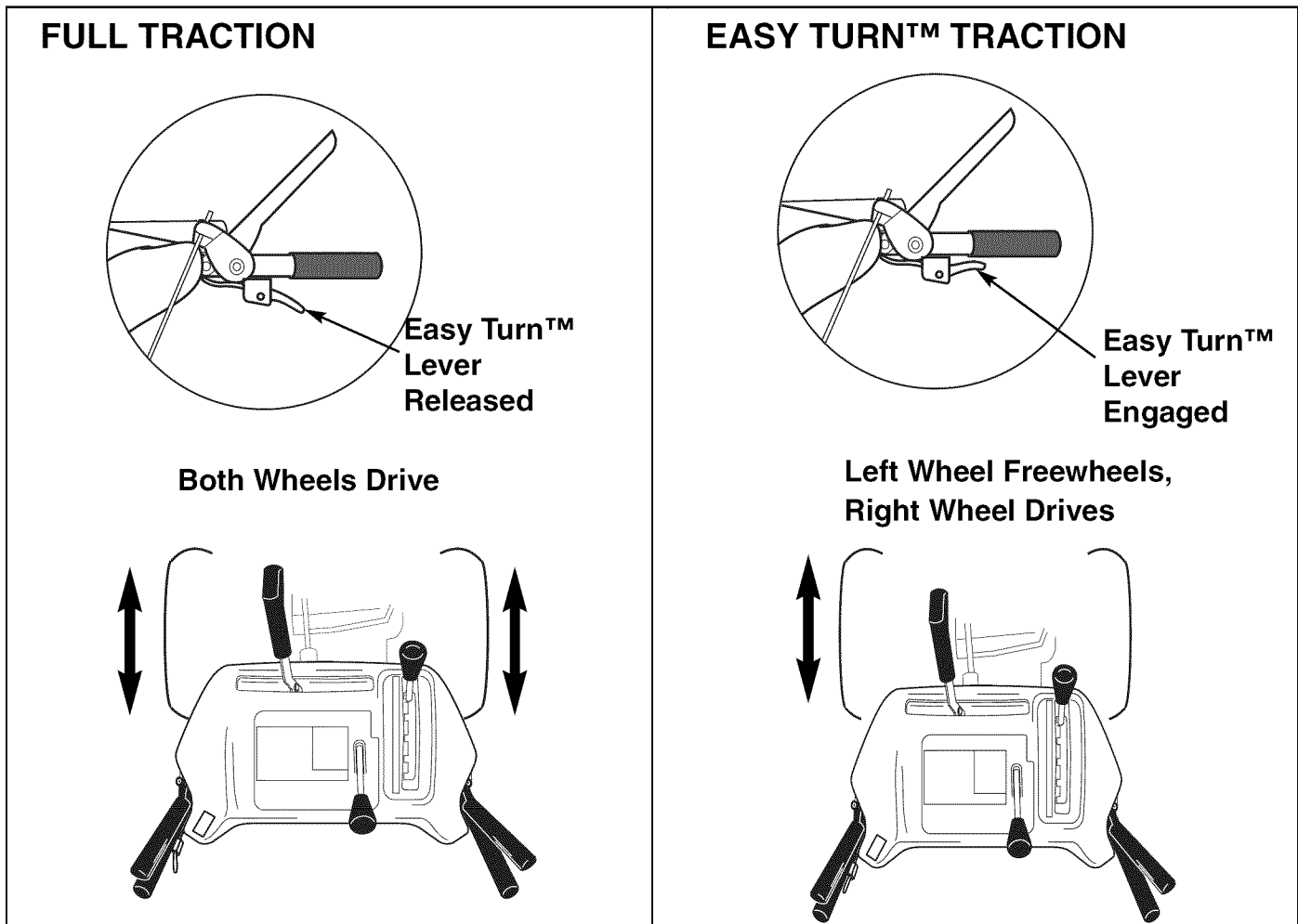

Figure 5. Easy Turn Control

EASY TURN™ FREEWHEELING AND TRACTION DRIVE LOCK

While Clearing Snow:

For easy turning when using the snowthrower, squeeze the Easy Turn™ lever (Figure 5). Engaging the Easy Turn™ lever releases the left traction wheel but allows the right wheel to continue driving (Figure 5). Releasing the Easy Turn™ lever automatically engages both drive wheels for full traction.

NOTE: The Easy Turn™ lever will be more difficult to activate under a heavy load. Activate the lever before beginning a turn.

When Pushing the Snowthrower:

(Units without Easy Turn)

For easy turning when pushing the snowthrower, disengage the right wheel using the traction lock pin (See Figure 6.)

1. Turn the unit off, remove the engine key, and disconnect the spark plug wire.

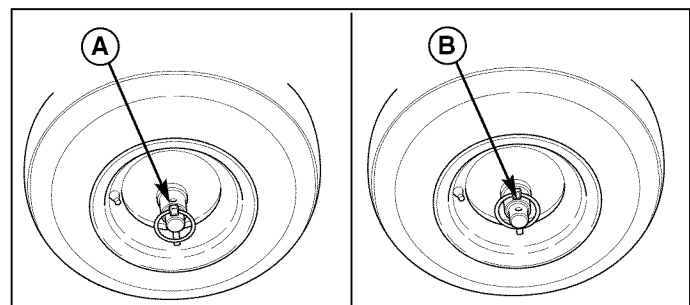

Figure 6. Traction Drive Lock

- A. Pin in Outer Hole (Freewheel)**
B. Pin in Inner Hole (Drive)

2. To **DISENGAGE** the traction drive lock, insert the Traction Lock Pin (A, Figure 6) through the outer hole in the right axle. The unit can now be pushed with minimal resistance.
3. To **ENGAGE** the traction drive lock, align the hole in the hub with the inner hole in the axle, and install the Traction Lock Pin (B).

NOTE: Be sure both wheels are locked (locking pin in inner hole) when clearing snow.

AFTER EACH USE

Normal use of the snowthrower may result in a build-up of packed snow in and around the starter cord housing and around engine controls. Heat from the engine will usually prevent the snow from freezing solid while the unit is running, but after the engine is shut down, some snow may continue melting from engine heat, and later freeze around some moving parts as the unit cools.

After each period of use, follow these steps to prevent freeze-up caused by ice formation in and around the engine controls and external parts.

1. Before shutting off the engine, pull the starter rope out 2 - 3 times, and allow it to rewind slowly. This will help clear packed snow from the starter cord area. Allow the engine to run for several minutes.
2. Stop the engine by moving the throttle lever (See Figure 1) down, turn the stop switch to the off position or by pulling out the engine key.
3. Brush snow and ice from the snowthrower. Be sure to clear engine and snowthrower controls, discharge chute, and chute rod gears, clutch cable areas, and anywhere else snow has accumulated.
4. Always remove the engine key and store in a safe place to prevent unauthorized use.

WARNING

Never store the unit (with fuel) in an enclosed, poorly ventilated structure. Fuel vapors can travel to an ignition source (such as a furnace, water heater, etc.) and cause an explosion.

Fuel vapor is also toxic to humans and animals.

5. If the snowthrower is kept in a cold shelter, fill the fuel tank to prevent condensation. Do not store near sparks or flame.

Note: The Engine Owner's Manual contains further information on preventing ice formation and freeze-up.

WARNING

Never store the unit, with gasoline in engine or fuel tank, in a heated shelter or in enclosed, poorly ventilated enclosures. Gasoline fumes may reach an open flame, spark or pilot light (such as a furnace, water heater, clothes dryer, etc.) and cause an explosion.

Handle gasoline carefully. It is highly flammable and careless use could result in serious fire damage to your person or property.

Drain fuel into an approved container outdoors away from open flame or sparks.

STORAGE

WARNING

Never store the unit (with fuel) in an enclosed, poorly ventilated structure. Fuel vapors can travel to an ignition source (such as a furnace, water heater, etc.) and cause an explosion.

Fuel vapor is also toxic to humans and animals.

Before you store your unit for the off-season, read the Maintenance and Storage instructions in the Safety Rules section, then perform the following steps:

- Disengage the PTO, set the parking brake, and remove the key.
- Perform engine maintenance and storage measures listed in the engine owner's manual. This includes draining the fuel system, or adding stabilizer to the fuel (do not store a fueled unit in an enclosed structure - see warning).

Before starting the unit after it has been stored:

- Check all fluid levels. Check all maintenance items.
- Perform all recommended checks and procedures found in the engine owner's manual.
- Allow the engine to warm up for several minutes before use.

Regular Maintenance

MAINTENANCE SCHEDULE

| MAINTENANCE REQUIRED | FREQUENCY | NOTES |
|--|-----------|--------------------|
| Check / Lubricate Free-Hand Linkage. | 10 Hours | 10W Oil |
| Lubricate snowthrower. | 10 Hours | 10W Oil and Grease |
| Check tire pressure. | Monthly | 20 psi (1.38 bar) |
| Change engine oil.*+ | 50 Hours: | See Engine Manual |
| Clean or replace spark plug.+ | Yearly | See Engine Manual |
| Check drive linkage/belt tension. | 4-6 Hours | See page 24 |
| Lubricate Axle Shafts. | Yearly | Lithium Grease |
| Check auger gear case lubrication.** | 25 Hours | Grease |
| Lubricate Auger Shaft.*** | 10 Hours | Lithium Grease |
| * Change original oil after two hours of operation. ** Check oil level each fall and spring. + See your engine Owner's Manual. ***Lubricate each fall and spring. | | |

CHECKING TIRE PRESSURE

The air pressure in each tire (Figure 7) should be equal for both tires for best performance. Be sure to keep caps on valves to prevent entry of debris into the valve stem when tires are filled.

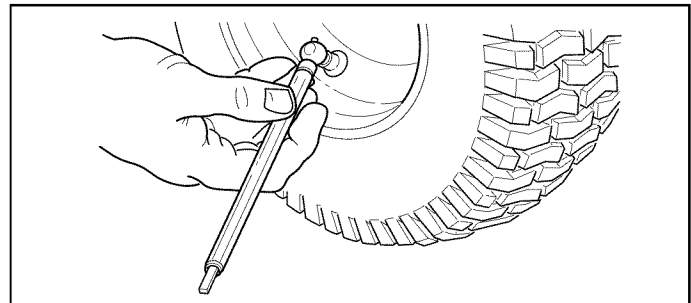

Figure 7. Checking Tire Pressure

| Size | PSI | bar |
|------------|-----|------|
| 15 x 5.0-6 | 20 | 1,38 |
| 16 x 4.8-8 | 14 | ,96 |

AUGER GEAR CASE LUBRICATION

1. Place the snowthrower on a level surface.
2. Remove the pipe plug (A, Figure 8).
3. Check the lubricant level. It should be level with the lower edge of the plug opening. If not, add Lithium grease.
4. Re-install pipe plug, and tighten securely.

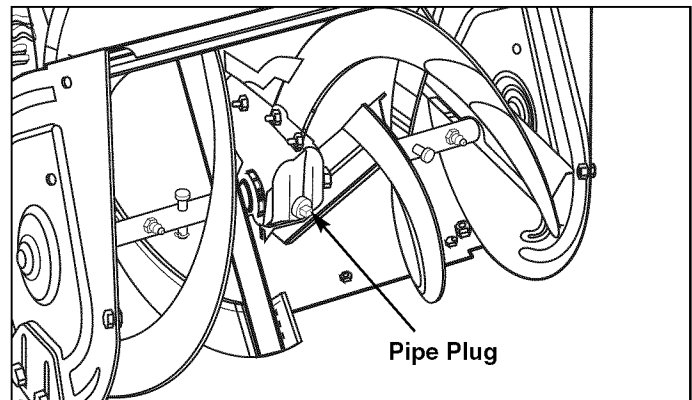

Figure 8. Auger Lubrication
A. Pipe Plug

LUBRICATION

IMPORTANT NOTE

It is very important that grease fittings on the auger shaft are lubricated regularly. If auger rusts to shaft, damage to worm gear may occur if shear pins do not break.

To prevent wheels rusting to axles, it is also necessary to remove the wheels and grease the axles regularly.

Remove wheels and grease axles once each year.

Apply 5W-30 synthetic motor oil to the friction disk drive hex shaft (A, Figure 10).

Apply medium weight (10W) oil to points shown (See Figures 9-12).

Generally, all moving metal parts should be oiled where contact is made with other parts. Keep oil and grease off belts, pulley grooves, drive disc, and friction disc.

LUBRICATION NOTES:



Grease locations indicated by grease gun symbol. Use grease fittings when present. Disassemble parts to apply grease to moving parts when grease fittings are not installed.



Oil locations indicated by oil can symbol. Do not allow oil to drip onto traction drive or friction disc. Do not lubricate remote deflector control.

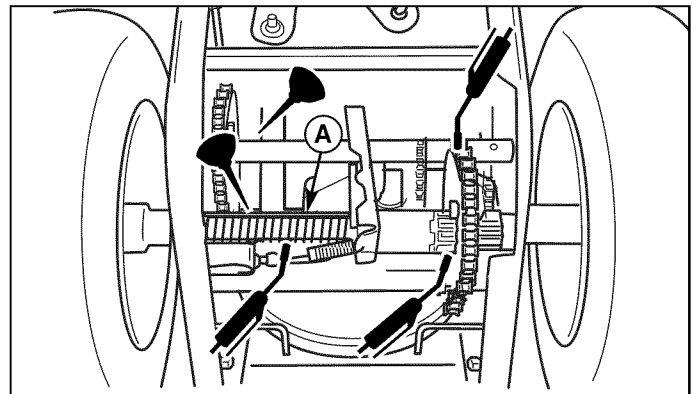

Figure 10. Drive Lubration
A. Hex Shaft (Behind Rod with Spring)

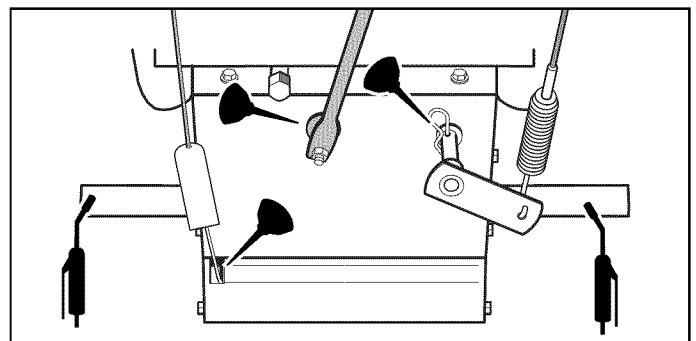

Figure 11. Lubricate Axles and Control Levers

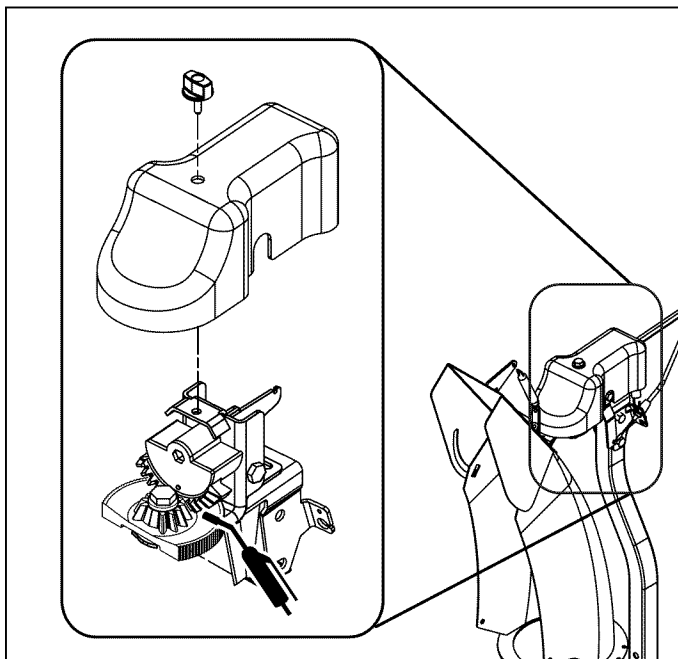

Figure 9. Lubricate Spout Rotator

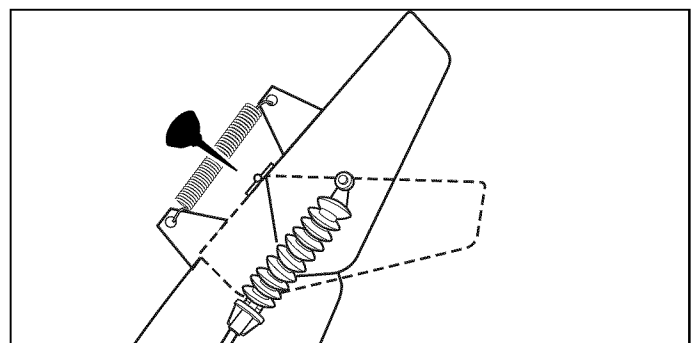

Figure 12. Deflector Hinge

Regular Maintenance

CHECK / LUBRICATE FREE-HAND LINKAGE

Check the function of the Free-Hand controls: the controls should function as described in the CONTROLS section. **It is critical for the safe operation of the unit that the controls disengage when released.**

Lubricate as shown in figure 13.

IMPORTANT NOTE

If the controls do not function properly, lubricate them. If lubrication does not rectify the problem, see your dealer. Under no circumstances should the unit be used if the controls are not functioning properly.

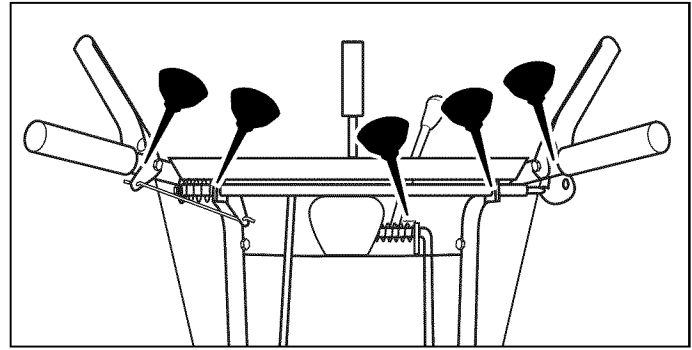

Figure 13. Lubricate Free Hand Control

IMPORTANT NOTE

It is very important that grease fittings on the auger shaft are lubricated regularly. If auger rusts to shaft, damage to worm gear may occur if shear pins do not break.

LUBRICATING THE AUGER SHAFT & ASSEMBLY

1. Remove cotter pin (C, Figure 14) and shear pin (B).
2. Use a grease gun and squirt several shots of grease into grease fitting (A).
3. Rotate auger assembly (D) several times to distribute the grease evenly. Repeat step 2.
4. Reinstall shear pin (B) and cotter pin (C).
5. Repeat procedure for other side.

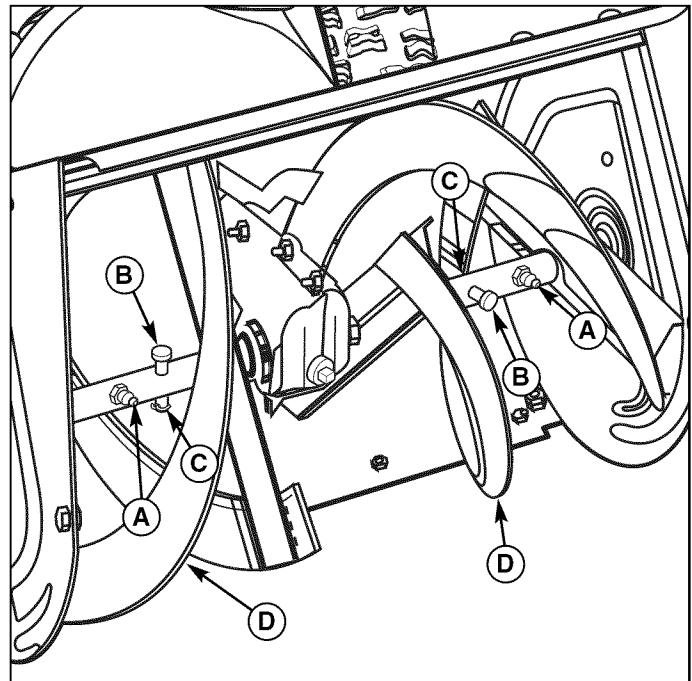

Figure 14. Lubricating the Auger Shaft Assembly
A. Grease Fittings C. Cotter Pins
B. Shear Pins D. Auger Assembly

Troubleshooting, Adjustments, Service

TROUBLESHOOTING

This section provides troubleshooting and service instructions. Locate the problem and check the possible cause/remedy in the order listed.

Also, refer to the engine manufacturer's Owner's Manual for additional information.

For problems not covered here, contact your local dealer.

WARNING

Before performing any adjustment or service to snowthrower, stop the engine and wait for moving parts to stop. Remove the key. To prevent accidental starting, disconnect the spark plug wire and fasten away from the plug.

| PROBLEM | POSSIBLE CAUSE | REMEDY |
|---|---|---|
| Engine fails to start. | 1. Key is OFF. | 1. Push key in to the ON position. |
| | 2. Failure to prime cold engine | 2. Press primer button twice and restart. |
| | 3. Fuel valve is in CLOSED position. | 3. Turn valve to OPEN position. |
| | 4. Out of fuel. | 4. Fill fuel tank. |
| | 5. Choke OFF - cold engine. | 5. Turn choke to ON, set throttle to FAST. |
| | 6. Engine flooded. | 6. Turn choke to OFF; try starting. |
| | 7. No spark. | 7. Check gap. Gap plug, clean electrode, or replace plug as necessary. |
| | 8. Water in fuel, or old fuel. | 8. Drain tank (Dispose of fuel at an authorized hazardous waste facility). Fill with fresh fuel. |
| Engine starts hard or runs poorly. | 1. Fuel mixture too rich. | 1. Move choke to OFF position. |
| | 2. Carburetor adjusted incorrectly. | 2. See your dealer for adjustments. |
| | 3. Spark plug faulty, fouled, or gapped improperly. | 3. Clean and gap, or replace. |
| | 4. Fuel cap vent is blocked. | 4. Clear vent. |
| Scraper bar does not clean hard surface. | 1. Skid shoes improperly adjusted. | 1. RAISE skid shoes (this lowers the scraper bar). |
| | 1. Skid shoes improperly adjusted. | 1. LOWER skid shoes (this raises the scraper bar.) |
| Auger does not rotate. | 1. Auger control not engaged. | 1. Engage auger control. |
| | 2. Foreign matter blocking auger. | 2. STOP engine and REMOVE the key. DISCONNECT the spark plug wire. Clear auger using clean-out tool. See warning in SAFETY RULES. |
| | 3. Auger drive clutch cable slack. | 3. Tighten to remove slack. See auger clutch cable adjustment. |
| | 4. Auger drive belt slipping. | 4. Check auger drive belt adjustment. |
| | 5. Broken belt. | 5. Replace belt. |
| | 6. Shear pin broken. | 6. Replace shear pin. |

Troubleshooting

| PROBLEM | POSSIBLE CAUSE | REMEDY |
|---|--|---|
| Auger rotates, but snow is not thrown far enough | 1. Chute deflector too low. | 1. Adjust deflector as necessary. |
| | 2. Engine speed too slow. | 2. Set speed to full throttle. |
| | 3. Ground speed too fast. | 3. Use slower speed selector setting. |
| | 4. Snowthrower discharge chute clogged. | 4. STOP engine and REMOVE the key. DISCONNECT the spark plug wire. Clear auger using clean-out tool. See warning in SAFETY RULES. |
| | 5. Auger belt loose or worn. | 5. Check auger drive belt adjustment |
| Poor traction | 1. Tires slipping. | 1. Check tire pressure and tread. |
| Auger does not stop when auger lever is released | 1. Free-Hand™ control is ACTIVE. | 1. Release BOTH auger engage Control AND Free-Hand™ Control to stop auger. |
| | 2. Auger clutch cable too tight or bent. | 2. Loosen or straighten clutch cable. |
| | 3. Auger drive belt out of adjustment. | 3. Adjust auger belt. |
| | 4. Auger belt guide out of adjustment. | 4. Adjust auger belt guide. |
| Snowthrower does not stop when drive lever is released | 1. Traction drive clutch cable bent or too tight. | 1. Loosen cable to add slack or replace. See adjustment procedure. |
| | 1. Traction drive clutch cable loose. | 1. Tighten to remove slack. See adjustment procedure. |
| | 2. Drive belt loose, broken, or stretched. | 2. Replace drive belt. |
| | 3. Drive roller chain damaged. | 3. Replace chain. |
| | 4. Traction lock pins in free-wheeling position (OUTER hole). | 4. Change traction lock pins to INNER hole to engage traction drive. |
| | 5. Friction disc worn. | 5. Replace disc (see your dealer). |
| Snowthrower does not drive and auger does not rotate. | 1. Belts are wet. | 1. Clean snow and moisture off of snowthrower and allow belts to dry. |
| | 2. Worm gear not adjusted properly. | 2. Adjust worm gear. See adjustment procedure. |
| Discharge control is difficult to operate. | 1. Gearing needs lubrication | 1. Oil or grease as required. |
| | 2. Gear not adjusted properly. | 2. Adjust gear. See adjustment procedure. |
| Snowthrower veers to one side. | 1. Tire pressure not equal. | 1. Check tire pressure. |
| | 2. One wheel is set in free-wheeling mode. (Traction Lock Pin is in the OUTER hole). | 2. Make certain the right traction lock pin is in the INNER holes (to engage traction drive, STD drive). |
| Excessive vibration. | 1. Loose parts or damaged auger. | 1. STOP engine and REMOVE the key. DISCONNECT the spark plug wire. Tighten all hardware. Replace auger if necessary. If vibration continues, see your dealer. |
| Drive fails to move snowthrower at slow speeds. | 1. Traction drive out of adjustment. | 1. Readjust drive, or shift speed selector setting up one speed faster. |
| Speed selector difficult to move or frozen in place. | 1. Hex shaft needs lubrication. | 1. Lubricate hex shaft with 5W-50 synthetic motor oil (see Maintenance). |

Adjustments

AUGER DRIVE ADJUSTMENT

WARNING

Do not over-tighten, as this may lift the lever and cause auger drive to be engaged without depressing the Auger Control.

1. Check that the auger cable (A, Figure 15) is on top of cable button (B) as show in Figure 15.
2. With the drive lever released, the hook (B, Figure 16b) should barely touch the lever (C) without raising it. There can be a maximum 1/32" clearance as shown.
3. To adjust, loosen nut (D) by holding the adjusting flats (A) and turning nut (D). Turn adjustment flats and hold screw. The adjustment screw is a phillips screw and the head can be held or turned by inserting a screwdriver through the spring (F).
4. Hold adjusting flats (A) and tighten nut (D).
5. Start unit and check auger. Auger must not be engaged unless auger control is depressed.
6. With engine running, fully depress auger control, the auger should engage and run normally.
7. Release auger control. **Auger must stop within 5 seconds.**
8. If auger does not operate properly, stop engine and recheck drive linkage adjustments.
9. If auger linkage is properly adjusted, auger drive belt tension may require adjustment. See adjusting the auger belt in this section of the manual

TRACTION DRIVE CABLE ADJUSTMENT

Initial Adjustment

WARNING

Do not over-tighten, as this may cause traction drive to engage without depressing the traction drive control (arm must remain in down position).

Verify that the cables are not over-tightened: With speed selector in position 1 and traction drive control fully released, push snowthrower forward. The unit should move forward freely.

If unit does not move forward freely, the cable has been over-tightened. To remedy, loosen tension on clutch cable slightly, and recheck.

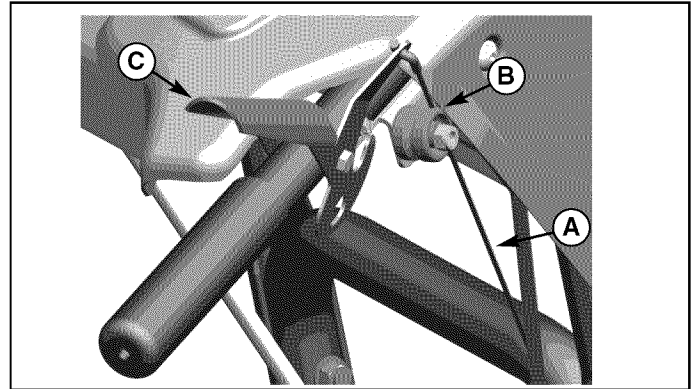

Figure 15. Auger Cable Button
A. Auger Drive Cable
B. Auger Cable Button
C. Lever

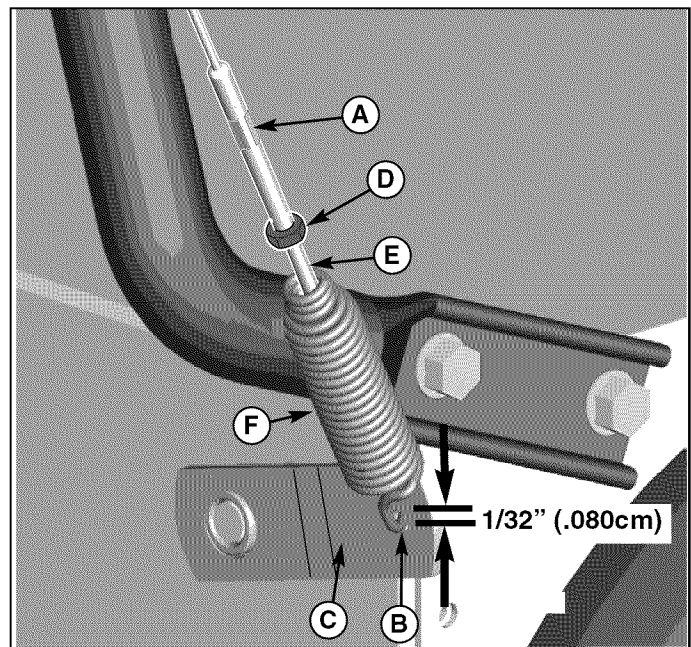

Figure 16. Auger Drive Adjustment
A. Adjusting Flats
B. Spring Hook
C. Lever
D. Nut
E. Adjustment Screw
F. Spring

1. With the drive lever released there should be no slack in the cable when moved slightly from side to side.
2. To adjust tension on the cable slide the cable boot (A, Figure 17) off the cable adjustment bracket (D).
3. Remove the "Z" hook (C) from the cable adjustment bracket (D) to a different adjustment hole. The cable should have no slack. The cable should have no tension or load.

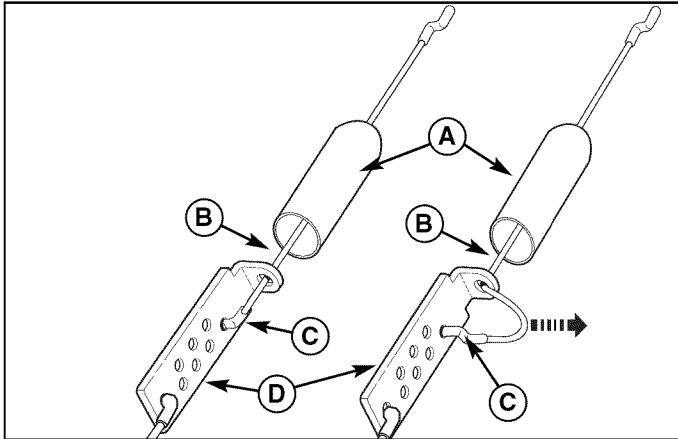

Figure 17. Traction Drive Cable Adjustment
A. Cable Boot
B. Traction Drive Cable
C. “Z” Hook
D. Cable Adjustment Bracket

Note: If the cable is too slack the unit will not drive. If the cable is too tight the drive will be engaged without pushing the handles down.

- Slide the cable boot (A) over the cable adjustment bracket.

Run-In Adjustment

ALL MODELS

- After 5 hours of use, check for proper adjustment. Readjust clutch cable if necessary by increasing tension on cable. A small amount of arm movement is permissible if unit passes operating checks described in the Warning above.

WARNING

Gasoline is highly flammable and must be handled with care. Drain gasoline outdoors. Never drain the tank when the engine is still hot from recent operation. Do not allow open flame, smoking or matches in the area. Avoid over-filling and wipe up any spills.

- Remove the gas from the gas tank.
- Disconnect the spark plug wire.
- Stand snowthrower on the front of the auger housing (C, Figure 25)
- Loosen the capscrews (A, Figure 25) on each side of the bottom panel (B).
- Remove the bottom panel (B).
- Position the shift speed lever in the lowest forward speed.

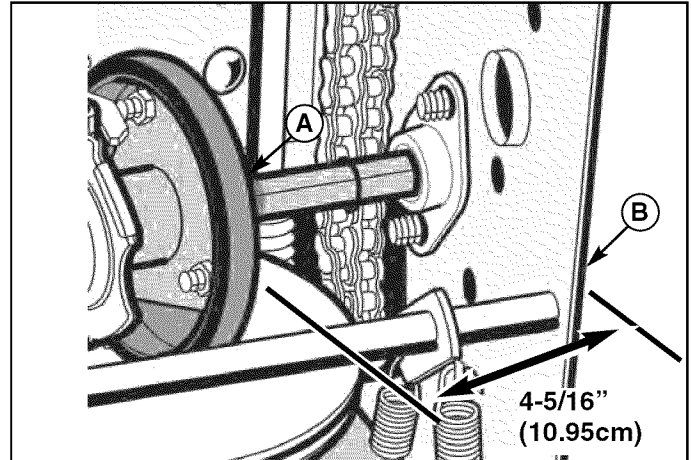

Figure 18. Friction Disc Measurement
A. Friction Disc
B. Frame

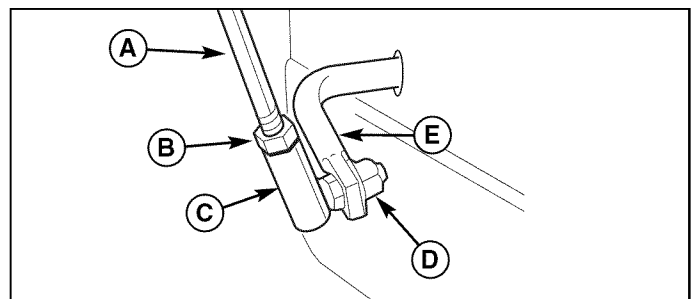

Figure 19. Speed Selector Linkage
A. Speed Selector Rod
B. Jam Nut
C. Ball Joint
D. Locknut
E. Shift Rod

- Note the position of the friction disc (A, Figure 18). The correct distance from the right side of the friction wheel to the outside of the frame is 4-5/16" (10.95 cm). If the friction disc is not in the correct position, adjust as follows.
- Position the shift speed lever in the lowest forward speed.
- Loosen the jam nut (B, Figure 19).
- Remove locknut (D).
- Move the friction disc (A, Figure 18) to the correct distance, 4-5/16" (10.95 cm).
- Turn the ball joint (C, Figure 15) until it is aligned with the mounting hole in the shifter rod (E). When aligned, attach the ball joint (C) to the shifter rod (E) and tighten the jam nut (B).
- Check that the snowthrower operates in R1. If not follow procedures 1-11 and readjust as necessary.
- Install the bottom panel (B, Figure 25) and tighten the capscrews (A).

Adjustments

EASY TURN™ CABLE ADJUSTMENT

If the Easy Turn™ cable has stretched, the gears will not disengage when the control lever is activated. Adjust the cable using the following procedure.

1. Turn the engine off and disconnect the spark plug wire.
2. Loosen the jam nut (B, Figure 20).
3. Turn the adjustment nut (A) to lengthen or shorten the cable. The cable should be tightened just until all slack is removed from the lever, however it must not engage the Easy Turn™ release without depressing the control lever.
4. Tighten the jam nut.

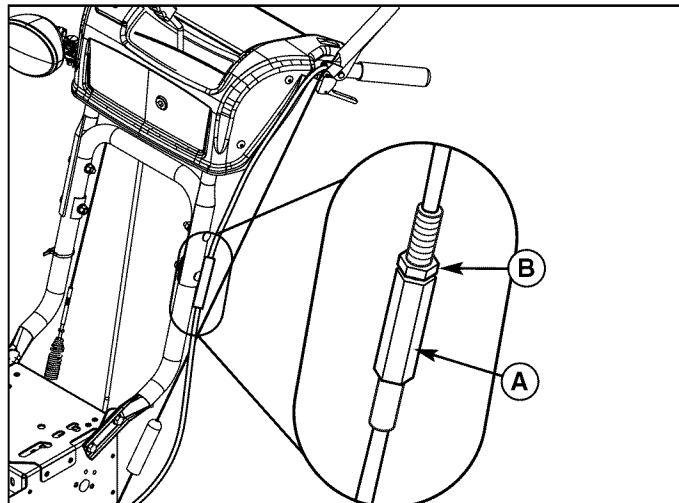

Figure 20. Cable Adjustment
A. Adjustment Nut
B. Jam Nut

BELT ADJUSTMENT

Auger Drive Belt

If your snowthrower will not discharge snow, check the control cable adjustment. If it is correct, then check the condition of the auger drive belt. If it is damaged or loose, replace it (see Belt Replacement in this section of the manual).

1. Disconnect spark plug wire.
2. Remove screw (B, Figure 21) from belt cover (A). Remove belt cover (A).
3. Loosen nut (D, Figure 20) on auger idler pulley (B) and move auger idler pulley towards belt about 1/8 inch (3mm).
4. Tighten nut (D).
5. Engage auger drive clutch. Check tension on belt (opposite idler pulley). Belt should deflect about 1/2 inch (12.5 mm) with moderate pressure see Figure 22). You may have to move the idler pulley more than once to obtain the correct tension.
6. Reinstall belt cover (A, Figure 21) securing with screws (B).
7. Whenever belts are adjusted or replaced, the cables will need to be adjusted. (see Cable Adjustment in this section of the manual).
8. Attach the spark plug wire.

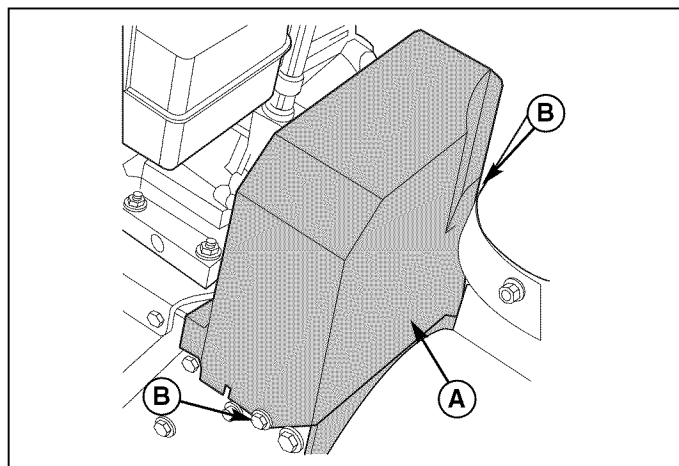

Figure 21. Belt Cover
A. Belt Cover
B. Screws

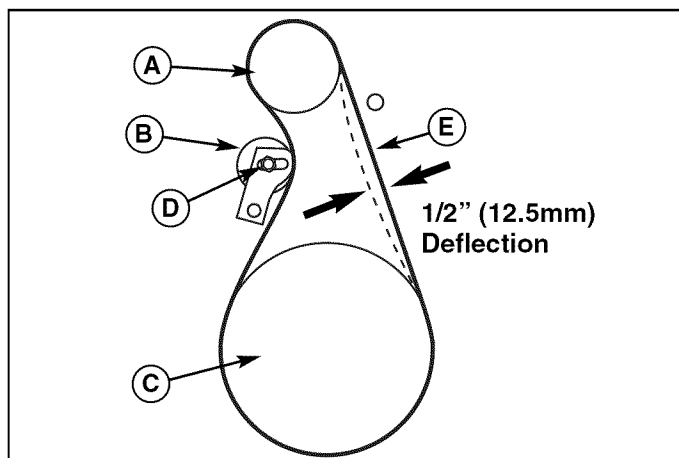

Figure 22. Auger Belt Deflection
A. Engine Drive Pulley
B. Idler Pulley (Engaged Position)
C. Auger Drive Pulley
D. Nut
E. Auger Belt

Traction Drive Belt

The traction drive belt has constant spring pressure and does not require an adjustment. If the traction drive belt is slipping, replace the belt. See Belt Replacement in this section of the manual.

SHEAR PIN REPLACEMENT

WARNING

Do not go near the discharge chute or auger when the engine is running. Do not run the engine with any cover or guard removed.

Under most circumstances, if the auger strikes an object which could cause damage to the unit, the shear pin will break. (This protects the gear box and other parts from damage.)

The shear pins are located on the auger shaft as shown in Figure 23. To replace the shear pins, tap out the broken pin with a pin punch, and install a new shear pin and cotter pin. **Do NOT replace shear pins with anything other than the correct grade replacement shear pin.** (Use of bolts, screws or a harder shear pin will lead to damaged equipment.)

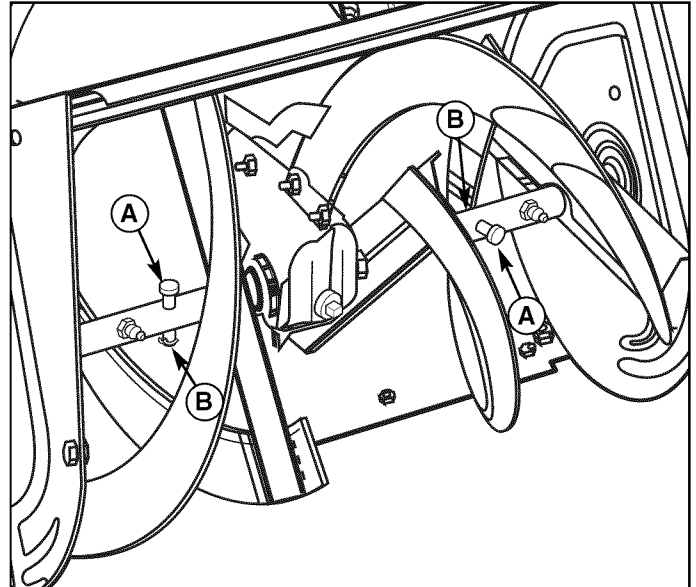

Figure 23. Shear Pins
A. Shear Pins
B. Cotter Pins

BELT GUIDE ADJUSTMENT

1. Disconnect spark plug wire.
2. Remove screw (B, Figure 21) from belt cover (A). Remove belt cover (A).
3. Measure the distance between the belt guide (B, Figure 24) and the belt (D). The distance should be 1/8 inch (3.18mm).
4. If adjustment is necessary, loosen belt guide cap-screw (C). Move belt guide (B) to correct position. Tighten capscrew (C).
6. Reinstall belt cover (A, Figure 21) securing with screws (B).
7. Reconnect spark plug wire.

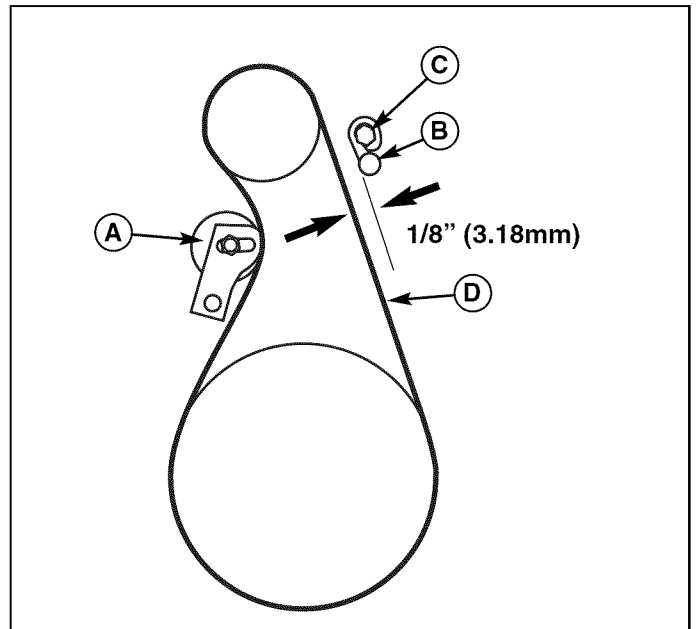

Figure 24. Belt Guide
A. Idler Pulley (Engaged Position)
B. Belt Guide
C. Capscrew
D. Belt

BELT REPLACEMENT

Auger Drive Belt

The drive belts are of special construction and must be replaced with original factory replacement belts available from your nearest authorized service center. Some steps require the assistance of a second person. If the auger drive belt is damaged, the snow thrower will not discharge snow. Replace the damaged belt as follows.

1. Disconnect the spark plug wire.
 2. Loosen the capscrews (A, Figure 25) on each side of the bottom panel (B).
 3. Remove the bottom panel (B).
 4. Loosen screw (B, Figure 21) from belt cover (A). Remove belt cover (A).
 5. Loosen the belt guide (B, Figure 26). Pull the belt guide away from the auger drive pulley (A).
 6. Pull the auger idler pulley (K) away from the auger drive belt (D) and slip the belt off of the idler.
 7. Remove the auger drive belt (D) from the engine pulley. To remove the auger drive belt (D), the auger drive pulley (C) may have to be partially rotated.
 8. Index or point the spout rotator to the center of the machine so the rotator control is in the center of the dash panel.
 9. Remove special nut (A, Figure 27) and cover (B).
 10. Remove hair pin (C) and slide rod forward about 3 inches. Until hex shaft separates from handle control.
 11. Remove the upper four capscrews (A, Figure 29) that hold together the auger housing (C) and the frame (D). Loosen the lower two capscrews (B). The auger housing (C) and the frame (D) can now be split apart for removal of the belt.
 12. Remove the old auger drive belt (D, Figure 26) from the impeller pulley. Replace the auger drive belt with an original factory replacement belt available from an authorized service center.
 13. Install the new auger drive belt (D) onto the impeller pulley.
- NOTE: To assemble the auger housing to the frame, have someone hold the auger clutch lever in the ENGAGED position. This will move the idler arm and pulley enough to allow the auger drive pulley to move back into position.*
14. Assemble the auger housing (C, Figure 29) to the frame with the four upper capscrews (A) that were removed in step 11. Tighten the two lower capscrews (B)

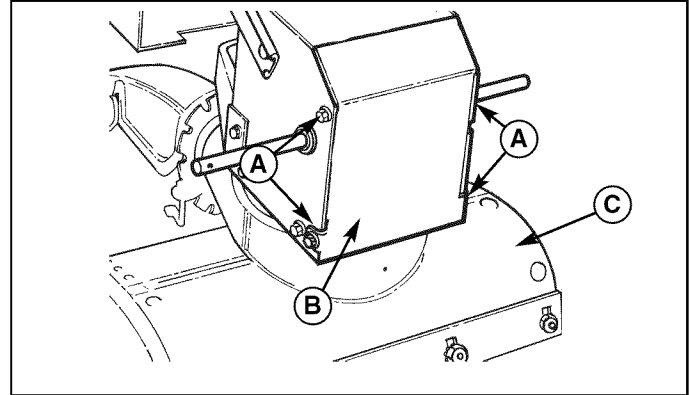

Figure 25. Bottom Cover

- A. Capscrews
- B. Bottom Panel
- C. Auger Housing

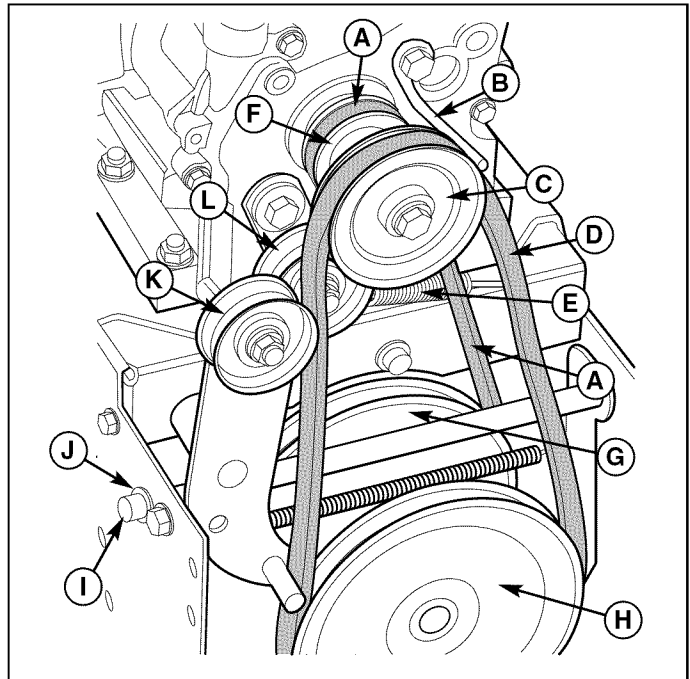

Figure 26. Pulleys and Belts

- A. Traction Drive Belt
- B. Belt Guide
- C. Auger Drive Pulley, Engine
- D. Auger Drive Belt
- E. Traction Drive Spring
- F. Traction Drive Pulley, Engine
- G. Traction Drive Pulley
- H. Impeller Pulley
- I. Swing Plate Axle Rod
- J. "E"-Ring
- K. Auger Idler Pulley
- L. Traction Drive Idler Pulley

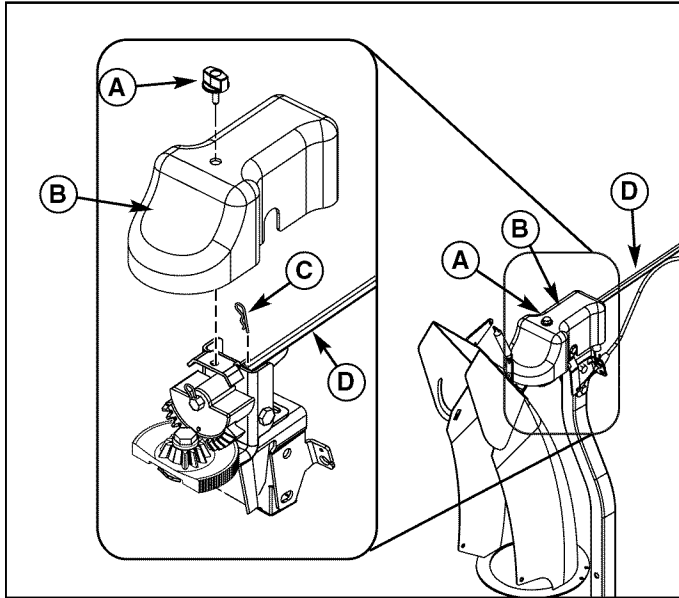

Figure 27. Spout Rotator Rod
A. Special Nut
B. Cover
C. Hair Pin
D. Spout Rotator Rod

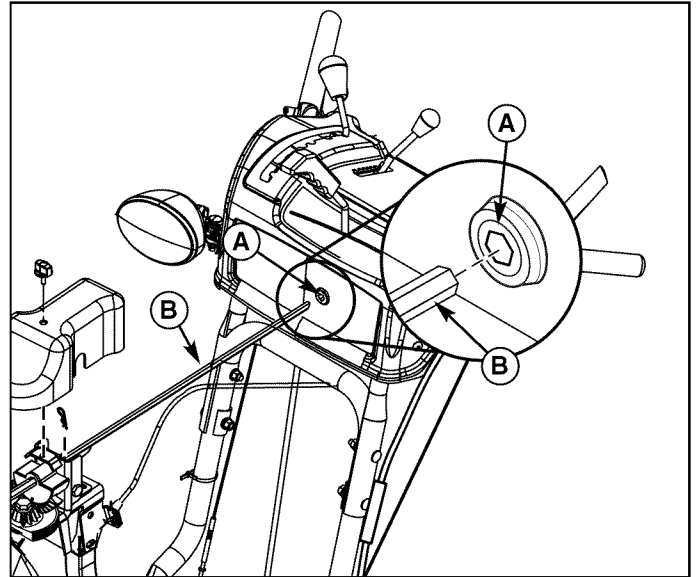

Figure 28. Install Spout Rotator Rod
A. Hex Dash Opening
B. Spout Rotator Rod

15. Index or point the spout rotator to the center of the machine so the rotator control is in the center of the dash panel.
16. Slide spout rotator rod (B, Figure 28) into hex dash opening (A).
17. Insert hair pin (C, Figure 27) into spout rotator rod (D).
18. Install cover (B) and secure with special nut (A).
19. Install the auger drive belt (D, Figure 26) onto the impeller pulley (H).
20. Slip the auger drive belt (D) under the idler pulley (K).
21. Adjust the auger drive belt. See “How To Adjust The Auger Drive Belt” in the Service section.
22. Adjust the belt guide. See “How To Adjust The Belt Guide” in the Service section.
23. Install the belt cover (A, Figure 21). Tighten screws (B).
24. Check the adjustment of the cables. See “How To Check And Adjust The Cables” in the Adjustment section.
25. Install the bottom panel (B, Figure 25).
26. Tighten the capscrews (A) on each side of the bottom panel (B).
27. Connect the spark plug wire.

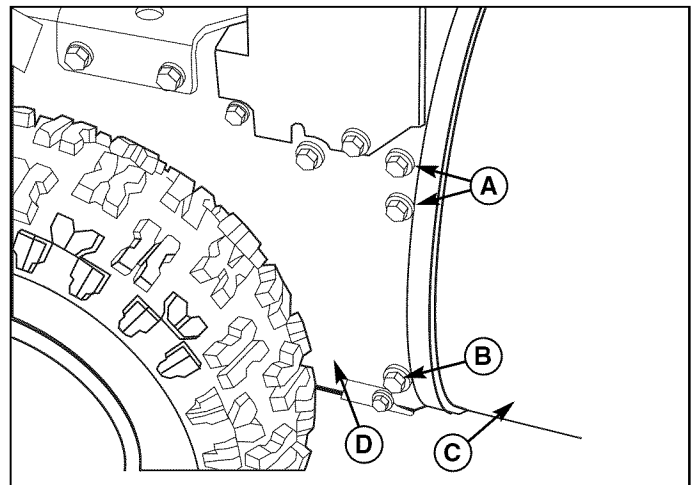

Figure 29. Frame and Axle Housing
A. Upper Capscrews
B. Lower Capscrews
C. Auger Housing
D. Frame

Service

Traction Drive Belt

If the snow thrower will not move forward, check the traction drive belt for wear or damage. If the traction drive belt is worn or damaged, replace the belt as follows.

1. Disconnect the spark plug wire.
 2. Remove the auger drive belt. See “How To Remove The Auger Drive Belt” in the Service section.
 3. Remove the e-ring (J, Figure 26) from one end of the swing plate axle rod (I).
 4. Remove the swing plate axle rod (I) to allow the swing plate (A, Figure 27) to pivot forward.
 5. Remove the traction drive spring (E, Figure 26).
 6. Remove the old traction drive belt (A) from the traction drive pulley (G) and from the traction drive pulley (F). Replace the traction drive belt (A) with an original factory replacement belt available from an authorized Dealer.
 7. Install the new traction drive belt (A) onto the traction drive pulley (G) and onto traction drive pulley (F).
 8. Make sure the traction drive idler pulley (L) is properly aligned with the traction drive belt (A).
 9. Attach the traction drive spring (E).
 10. Install the swing plate axle rod (I) and secure with the e-ring (J) removed earlier (E).
 11. The bottom of the swing plate (A, Figure 30) must be positioned between the alignment tabs (B). Make sure the swing plate is properly secured.
- NOTE: If the drive will not engage after the traction drive belt has been replaced, then check to make sure that the swing plate is positioned between the alignment tabs.*
12. Install and adjust the auger drive belt. See Belt Replacement in this section of the manual.
 13. Adjust the belt guide. See Belt Adjustment in this section of the manual.
 14. Install the bottom panel (B, Figure 25).
 15. Tighten the capscrews (A) on each side of the bottom panel (B).
 16. Reinstall belt cover (A, Figure 21) securing with screws (B).
 17. Check the adjustment of the cables. See Cable Adjustment in this section of the manual.
 18. Connect the spark plug wire.

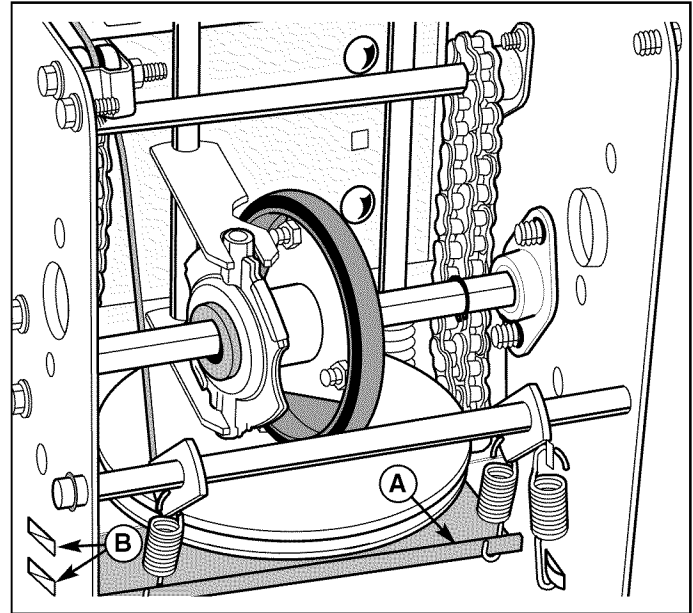

Figure 30. Traction Belt Change
A. Swing Plate
B. Alignment Tabs

Specifications

NOTE: Specifications are correct at time of printing and are subject to change without notice.

* Power Ratings

The power ratings for an individual engine model are initially developed by starting with SAE (Society of Automotive Engineers) code J1940 (Small Engine Power & Torque Rating Procedure) (Revision 2002–05). Given both the wide array of products on which our engines are placed, and the variety of environmental issues applicable to operating the equipment, it may be that the engine you have purchased will not develop the rated horsepower when used in a piece of power equipment (actual “on-site” power). This difference is due to a variety of factors including, but not limited to, the following: differences in altitude, temperature, barometric pressure, humidity, fuel, engine lubrication, maximum governed engine speed, individual engine to engine variability, design of the particular piece of power equipment, the manner in which the engine is operated, engine run-in to reduce friction and clean out of combustion chambers, adjustments to the valves and carburetor, and other factors. The power ratings may also be adjusted based on comparisons to other similar engines utilized in similar applications, and will therefore not necessarily match the values derived using the foregoing codes.

ENGINE:

8.5 HP* Briggs & Stratton

| | |
|--------------|----------------------|
| Make | Briggs & Stratton |
| Model | Power Built |
| Horsepower | 8.5 @ 3600 rpm |
| Displacement | 15.2 Cu. in (249 cc) |
| Oil Capacity | 19 oz. (.56 L) |

9.5 HP* Briggs & Stratton

| | |
|--------------|----------------------|
| Make | Briggs & Stratton |
| Model | Intek Snow |
| Horsepower | 9.5 @ 3600 rpm |
| Displacement | 18.6 Cu. in (305 cc) |
| Oil Capacity | 28 oz. (.84 L) |

10.5 HP* Briggs & Stratton

| | |
|--------------|----------------------|
| Make | Briggs & Stratton |
| Model | Intek Snow |
| Horsepower | 10.5 @ 3600 rpm |
| Displacement | 18.6 Cu. in (305 cc) |
| Oil Capacity | 28 oz. (.84 L) |

11.5 HP* Briggs & Stratton

| | |
|--------------|----------------------|
| Make | Briggs & Stratton |
| Model | Intek Snow |
| Horsepower | 11.5 @ 3600 rpm |
| Displacement | 18.6 Cu. in (305 cc) |
| Oil Capacity | 28 oz. (.84 L) |

CHASSIS:

| | |
|-----------------------------|--|
| Wheels | |
| - 8526, 9528, | Tire Size: 15 x 5 |
| | Inflation Pressure: 20 psi (1,37 bar) |
| - 10530, 11532, | Tire Size: 16 x 4.8 |
| | Inflation Pressure: 14 psi (.96 bar) |
| Spout Rotation | 200 Degrees |
| Impeller | 12" (30cm) 4 Blade Ribbon Flighted Steel |
| Auger Opening Height | 21" (53 cm) |
| Drive System | Friction Disc, 6 Forward Speeds, 2 Reverse |

DIMENSIONS

| | |
|---------------------------------|-----------------|
| Effective Clearing Width | |
| - 8526 | 26" (66cm) |
| - 9528 | 28" (71cm) |
| - 10530 | 30" (76cm) |
| - 11532 | 32" (81cm) |
| Length | |
| - 8526 | 57.5" (146cm) |
| - 9528 | 57.5" (146cm) |
| - 10530 | 57.5" (146cm) |
| - 11532 | 57.5" (146cm) |
| Height | |
| - 8526 | 44.1" (112cm) |
| - 9528 | 44.1" (112cm) |
| - 10530 | 45" (114cm) |
| - 11532 | 45" (114cm) |
| Weight | |
| - 8526 | 248lbs. (112kg) |
| - 9528 | 255lbs. (116kg) |
| - 10530 | 255lbs. (116kg) |
| - 11532 | 260lbs. (118kg) |

Parts & Accessories

REPLACEMENT PARTS

Replacement parts are available from your authorized dealer. Always use genuine Simplicity / Snapper Service Parts.

MAINTENANCE ITEMS

Many convenient and helpful service and maintenance items are available from you authorized dealer. Some of these items include:

| | |
|-------------------|--------------------|
| Engine Oil | Tire Sealant |
| Touch-Up Paint | Degrimer/Degreaser |
| Grease Gun Kit | Gas Stabilizer |
| 8 oz. Grease Tube | |

TECHNICAL MANUALS

Additional copies of this manual are available, as well as fully illustrated parts lists. These manuals show all of the product's components in exploded views (3D illustrations which show the relationship of parts and how they go together) as well as part numbers and quantities used. Important assembly notes and torque values are also included.

For applicable manuals currently available for your model, contact our Customer Publications Department at 262-284-8519 (Simplicity) 1-866-313-6682 (Snapper) Have the information listed in the box below available when phoning in your request. Technical manuals can be downloaded from

www.simplicitymfg.com

www.snapper.com

| | |
|------------------------------|-------|
| Model: | _____ |
| Mfg. No.: | _____ |
| Your Name: | _____ |
| Address: | _____ |
| City, State, Zip: | _____ |
| Visa/Mastercard No.: | _____ |
| Card Expiration Date: | _____ |



MANUFACTURING, INC.
500 N Spring Street / PO Box 997
Port Washington, WI 53074-0997

www.SimplicityMfg.com



PRODUCTS
535 Macon Street
McDonough, GA 30253

www.Snapper.com

© Copyright 2006, Briggs & Stratton.
All Rights Reserved. Printed in USA.

