

**Simplicity**

MANUFACTURING, INC.

**Simplicity**

**SNAPPER**

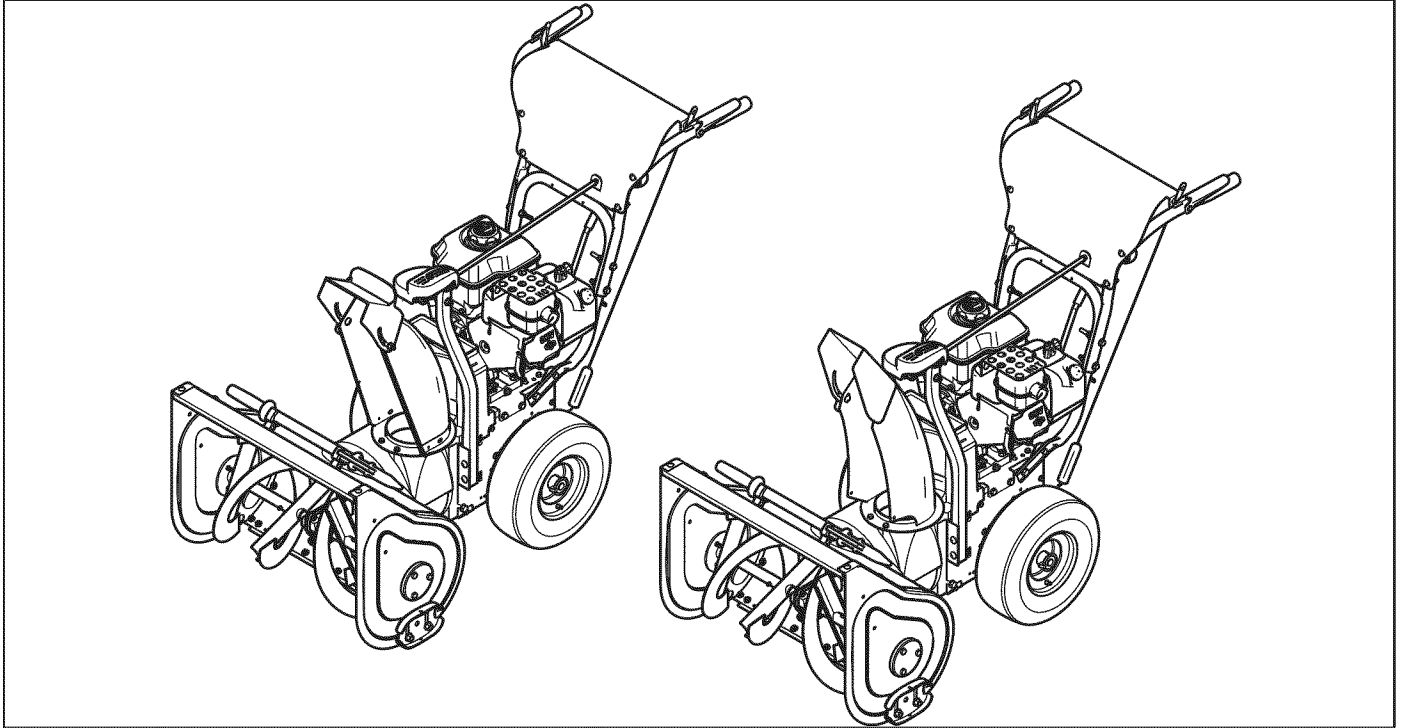

# Intermediate Frame Snowthrowers

## Initial setup

This Dealer Setup Instruction covers the following products:

### Intermediate Frame Snowthrowers

Mfg. No.	Description
1695302	SMI I1924E, 9GT, B&S 24
1695311	SMI I1924EX, 9GT, B&S 24 (CE)
1695410	SMI I1924EX, 9GT, B&S 24 (CE)
1695313	SNP I1924E, 9GT, B&S 24
1695314	SNP I1924EX, 9GT, B&S 24 (CE)
1695411	SNP I1924EX, 9GT, B&S 24 (CE)

**CE**

Briggs & Stratton Yard Power Products Group  
Copyright © 2007 Briggs & Stratton Corporation  
Milwaukee, WI USA. All Rights Reserved

Form No. 1735249

09/2007

TP 300-4681-01-IW-SN

## SAFETY RULES



Read these safety rules and follow them closely. Failure to obey these rules could result in loss of control of unit, severe personal injury or death to you, or bystanders, or damage to property or equipment. The triangle  in text signifies important cautions or warnings which must be followed.

### GENERAL OPERATION

- Read, understand, and follow all instructions in the manual and on the unit before starting.
- Only allow responsible adults, who are familiar with the instructions, to operate the unit (local regulations can restrict operator age).
- Clear the area of objects such as rocks, toys, wire, etc., which could be picked up and thrown.
- Be sure the area is clear of other people. Stop unit if anyone enters the area.
- Always look down and behind before and while travelling in reverse.
- Be aware of the discharge direction and do not point it at anyone. Do not point the discharge at glass enclosures, automobiles, or windows.
- Disengage all clutches (release drive and auger control levers) before starting the engine.
- Never leave a running unit unattended. Always disengage the auger and traction controls, stop engine, and remove keys.
- Stop engine before unclogging chute.
- Operate only in daylight or good artificial light.
- Do not operate the unit while under the influence of alcohol or drugs.
- Watch for traffic when operating near or crossing roadways.
- Use extra care when loading or unloading the unit into a trailer or truck.
- Keep in mind the operator is responsible for accidents occurring to other people or property.
- Data indicates that operators, age 60 years and above, are involved in a large percentage of power equipment-related injuries. These operators should evaluate their ability to

- operate the unit safely enough to protect themselves and others from injury.
- All operators should seek and obtain professional and practical instruction.
- Always wear substantial footwear and appropriate winter clothing. Wear foot-ware that improves traction on slippery slopes. DO NOT wear long scarves or loose clothing that could become entangled in moving parts.
- Before using, always visually check that all hardware is present, in-tact, and secure. Replace worn or damaged parts.
- Never operate the machine with defective guards, or without safety protective devices in place.
- Stop engine before: refuelling, removing an attachment, making adjustments (unless the adjustment can be made from the operator's position).
- Follow the manufacturer's recommendation for wheel weights or counterweights.
- Adjust skid shoe height to clear gravel or crushed rock surfaces.
- Do not touch snowthrower parts which may be hot from operation. Allow such parts to cool before attempting to service the unit.

### CLEARING A CLOGGED DISCHARGE CHUTE

Hand contact with the rotating impeller inside the discharge chute is the most common cause of injury associated with snowthrowers. Always use a clean out tool, not your hands, to clean out the discharge chute.

To clear the chute:

1. SHUT OFF THE ENGINE.
2. Wait 10 seconds to be sure the impeller blades have stopped rotating.
3. Always use a clean out tool, not your hands.

### SLOPE OPERATION

#### WARNING

Never operate on slopes greater than 17.6 percent (10°) which is a rise of 3-1/2 feet (106 cm) vertically in 20 feet (607 cm) horizontally.

When operating on slopes use additional wheel weights or counterweights. See your dealer to determine which weights are available and appropriate for your unit.

Select slow ground speed before driving onto slope. Travel UP and DOWN the slope, never across the face, use caution when changing directions and DO NOT START OR STOP ON SLOPE.

Slopes are a major factor related to loss-of-control and tip-over accidents, which can result in severe injury or death. All slopes require extra caution. If you cannot back up the slope or if you feel uneasy on it, do not operate on it.

### EMISSIONS

- Engine exhaust from this product contains chemicals known, in certain quantities, to cause cancer, birth defects, or other reproductive harm.
- Look for the relevant Emissions Durability Period and Air Index information on the engine emissions label.

#### Do

- See your authorized dealer for recommendations counterweights to improve stability.
- Travel up and down slopes, not across.
- Remove obstacles such as rocks, tree limbs, etc.
- Watch for holes, ruts, or bumps. Uneven terrain could overturn the unit. Snow can hide obstacles.
- Use slow speed. Tires may lose traction on slopes. Choose a low gear so that you will not have to stop or shift while on the slope.
- Keep all movement on the slopes slow and gradual. Do not make sudden changes in speed or direction.
- Always keep unit in gear especially when traveling downhill.

#### Do Not

- Do not start or stop on a slope. If tires lose traction, disengage the auger and proceed slowly straight down the slope.
- Do not turn on slopes unless necessary, and then, turn slowly and gradually downhill, if possible.
- Do not operate near drop-offs, ditches, or embankments. The unit could suddenly turn over if a wheel is over the edge of a cliff or ditch, or if an edge caves in.
- Do not operate on wet surfaces. Reduced traction could cause sliding.
- Do not shift to neutral and coast down hills.

## Table of Contents

<b>Unpacking</b> . . . . .	<b>4</b>
1. Uncrate . . . . .	4
2. Check Tire Pressure . . . . .	4
3. Install Handles . . . . .	5
4. Secure Dash . . . . .	5
5. Install Chute . . . . .	6
6. Install Chute Rotator Crank . . . . .	6
7. Tube Handle Levers . . . . .	7
8. Auger Shaft Lubrication . . . . .	7
9. Auger Drive Lubrication . . . . .	7
10. Auger Shaft Shear Pins . . . . .	8
11. Deflector Hinge Lubrication . . . . .	8
12. Axles and Control Lever Lubrication . . . . .	8
13. Spout Rotator Lubrication . . . . .	9
14. Hand Control Lubrication . . . . .	9
15. Engine Lubrication . . . . .	9
<b>Perform Safety Checks</b> . . . . .	<b>10</b>
Check Engine Controls . . . . .	10
Check Snowthrower Controls . . . . .	11
Check Operations . . . . .	11
<b>Adjustments</b> . . . . .	<b>12</b>
Auger Drive Adjustment . . . . .	12
Traction Drive Adjustment . . . . .	13
Scraper Bar & Skid Shoe Adjustment . . . . .	14
Belt Adjustment . . . . .	15
<b>Belt Replacement</b> . . . . .	<b>16</b>
Auger Drive belt . . . . .	16
Traction Drive Belt . . . . .	18

# Intermediate Frame Snowthrowers

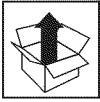

# 1

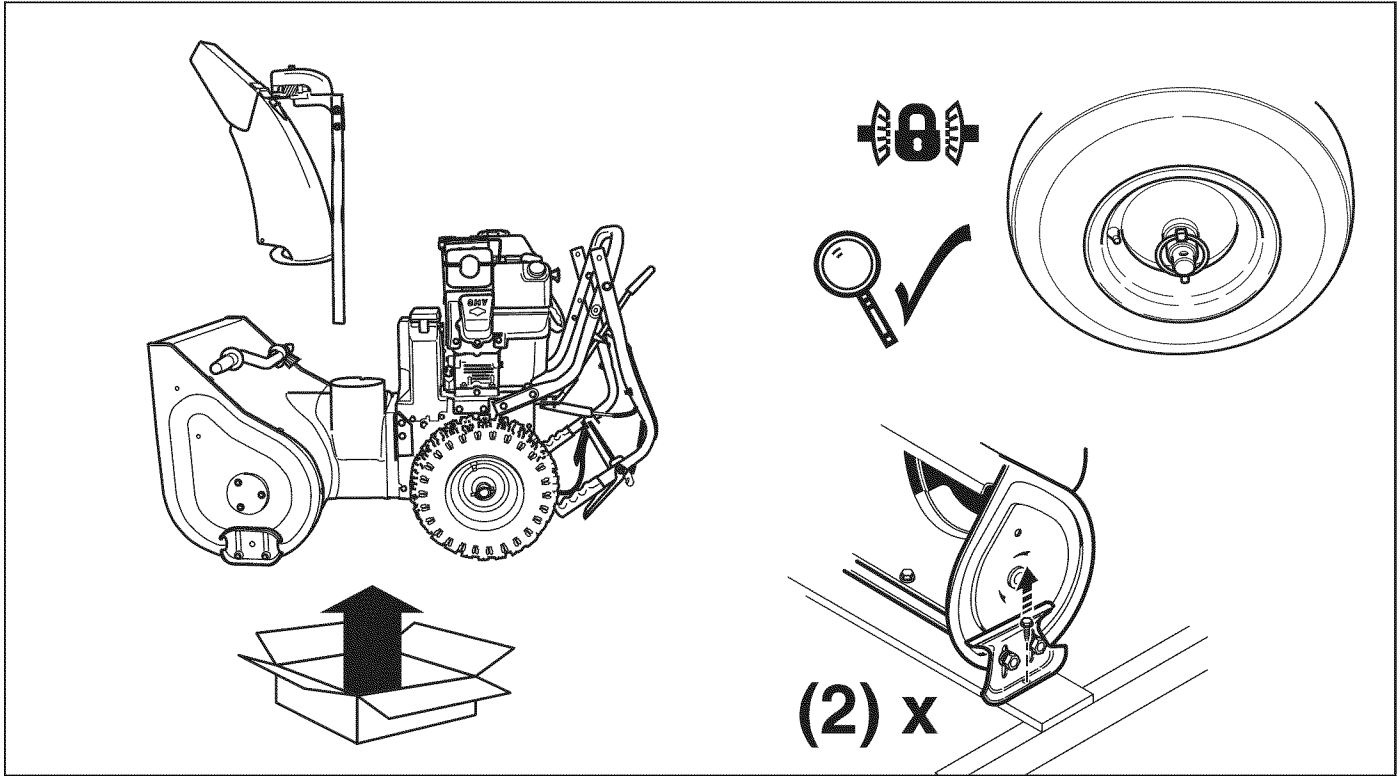

# 2

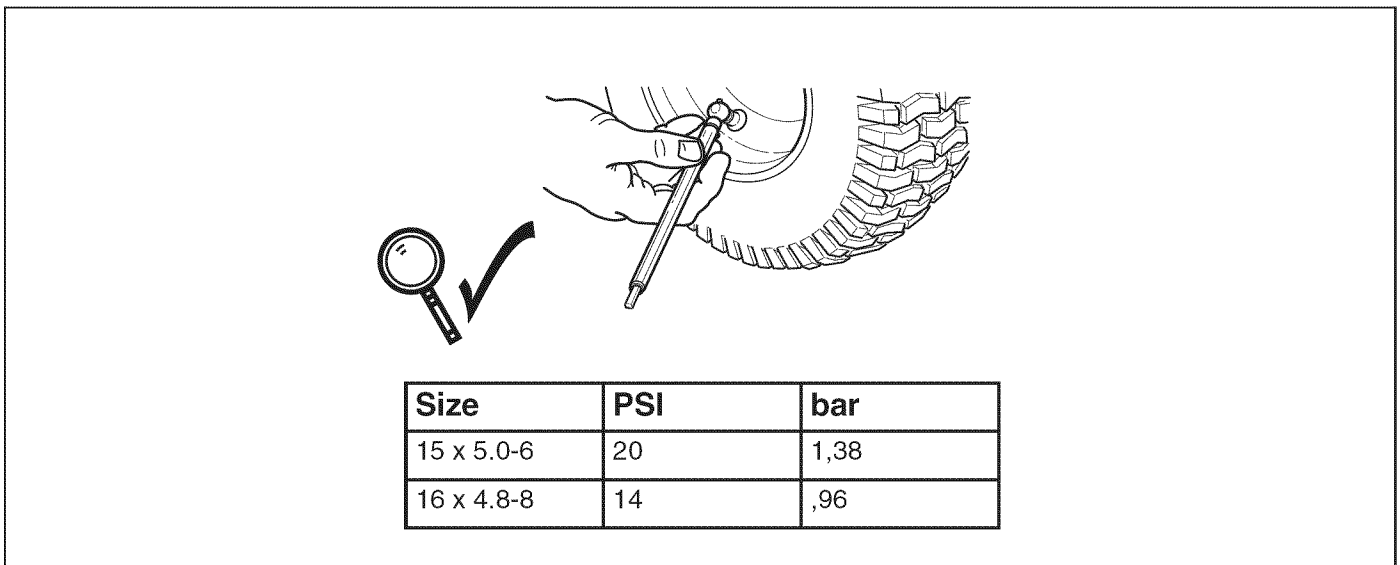



3

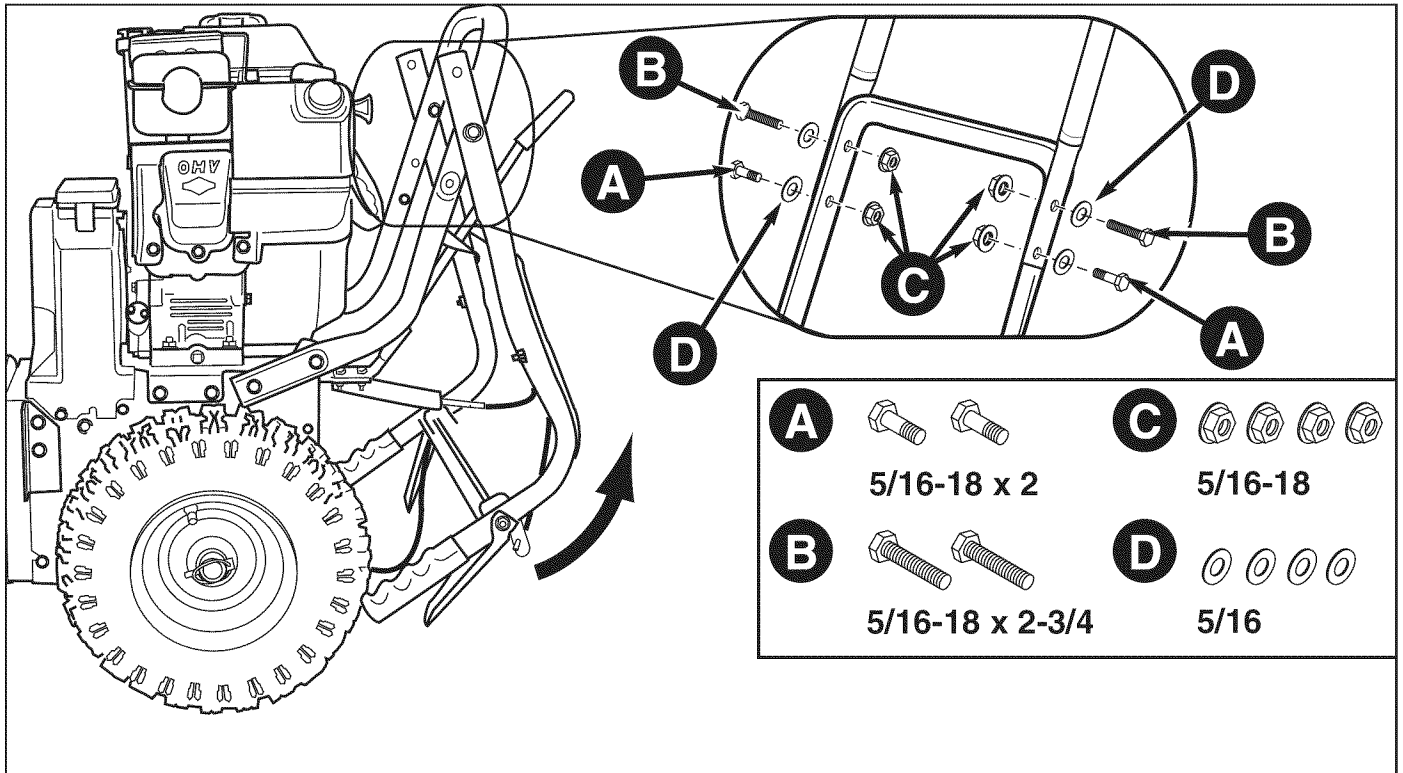
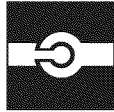

4

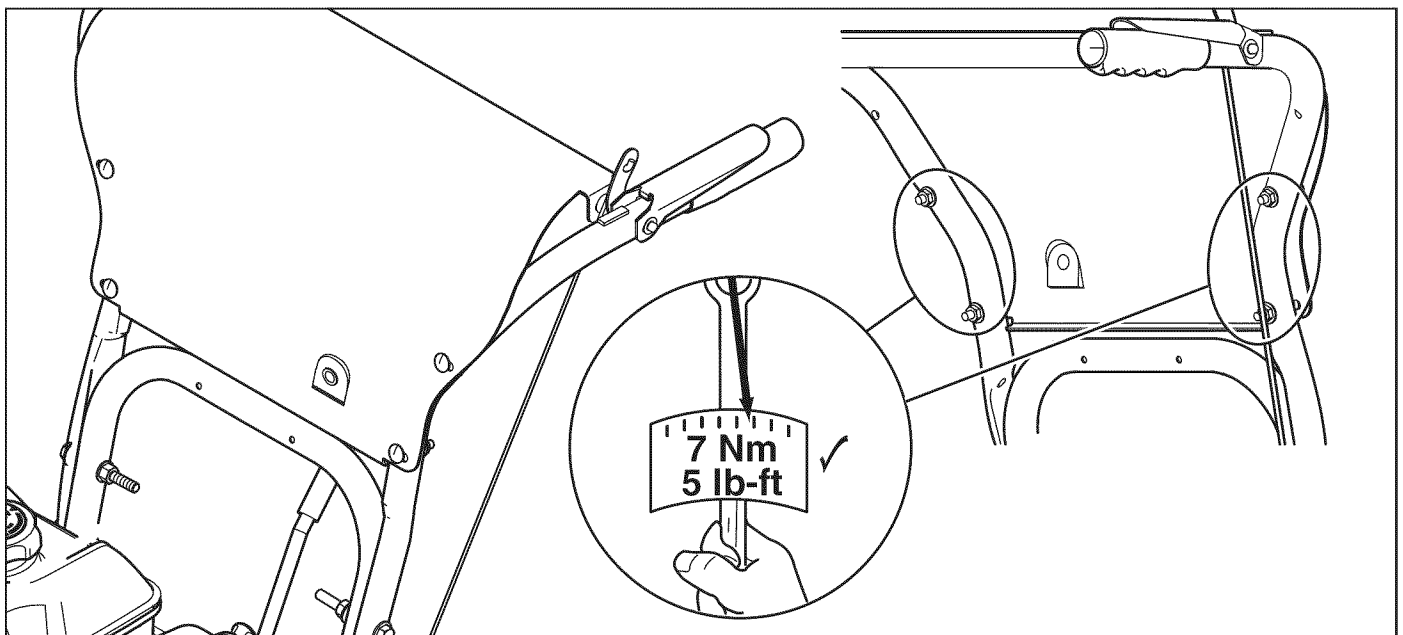

# Intermediate Frame Snowthrowers

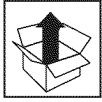

# 5

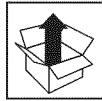
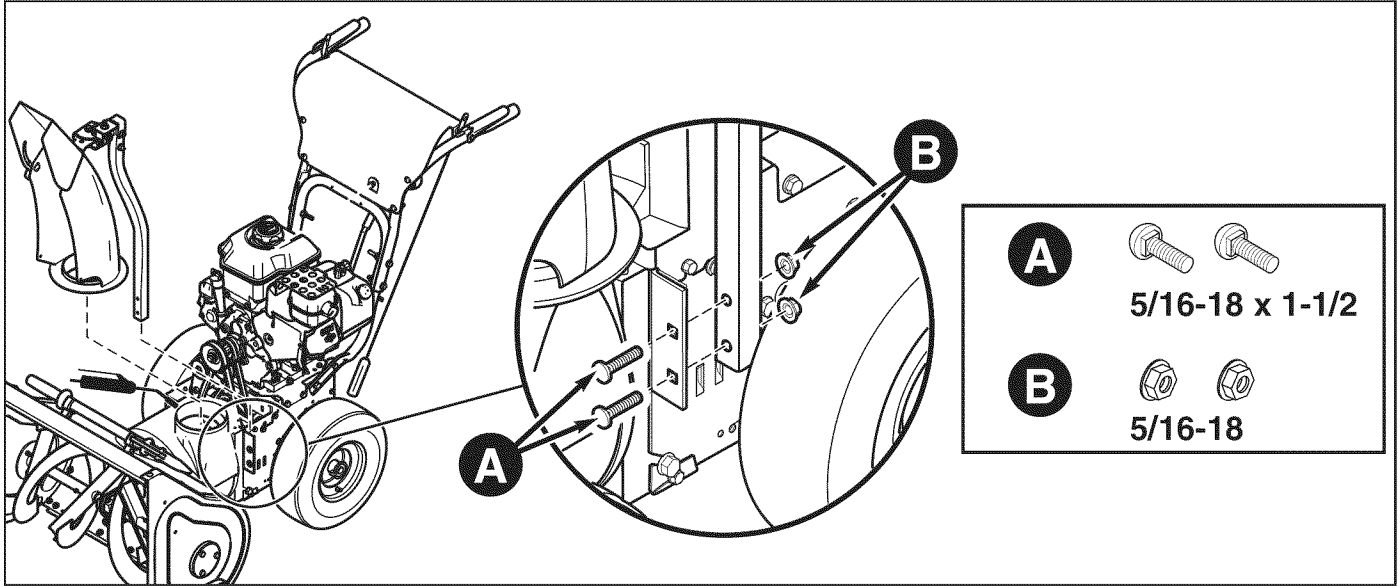

# 6

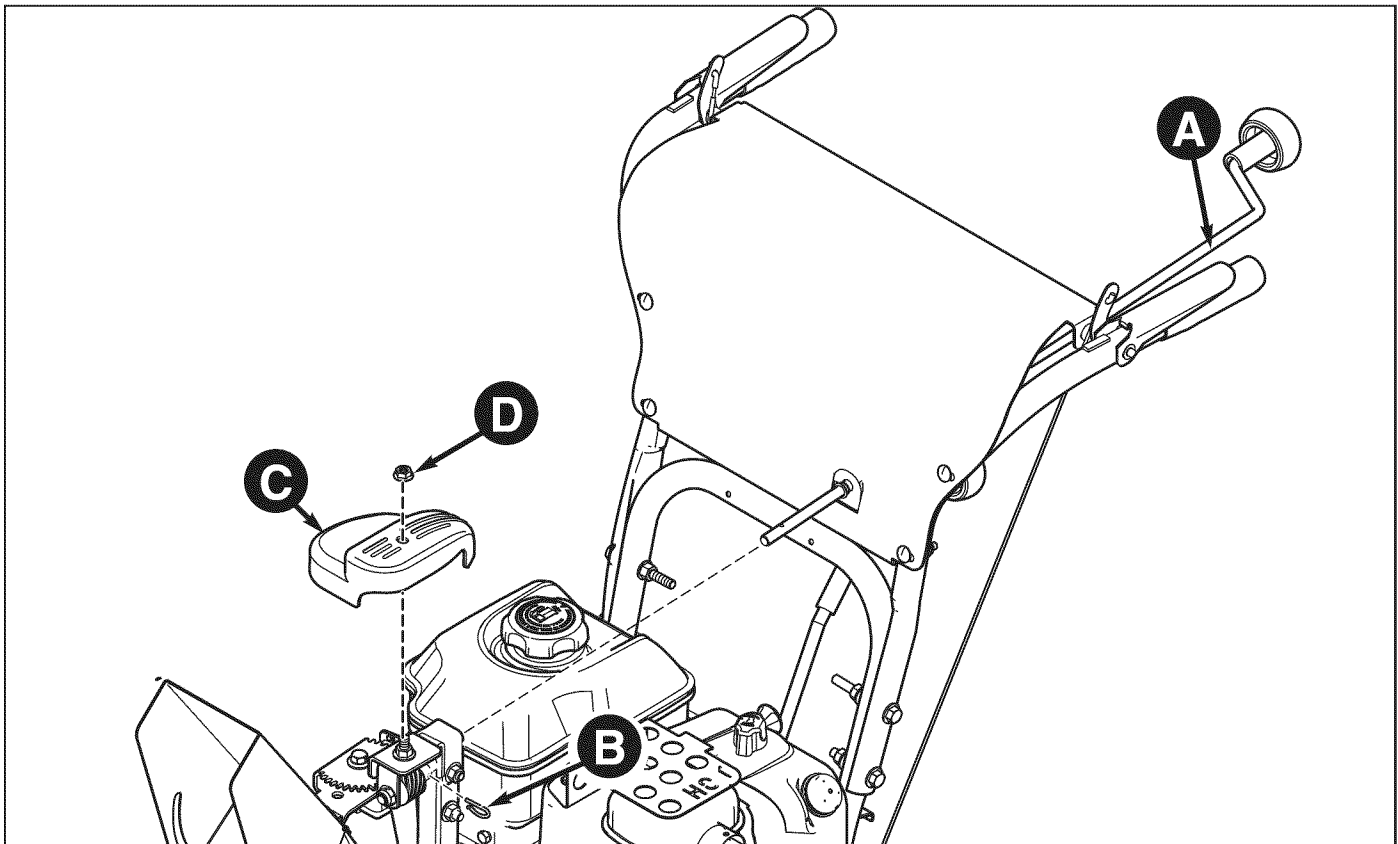
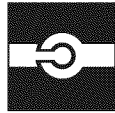



7

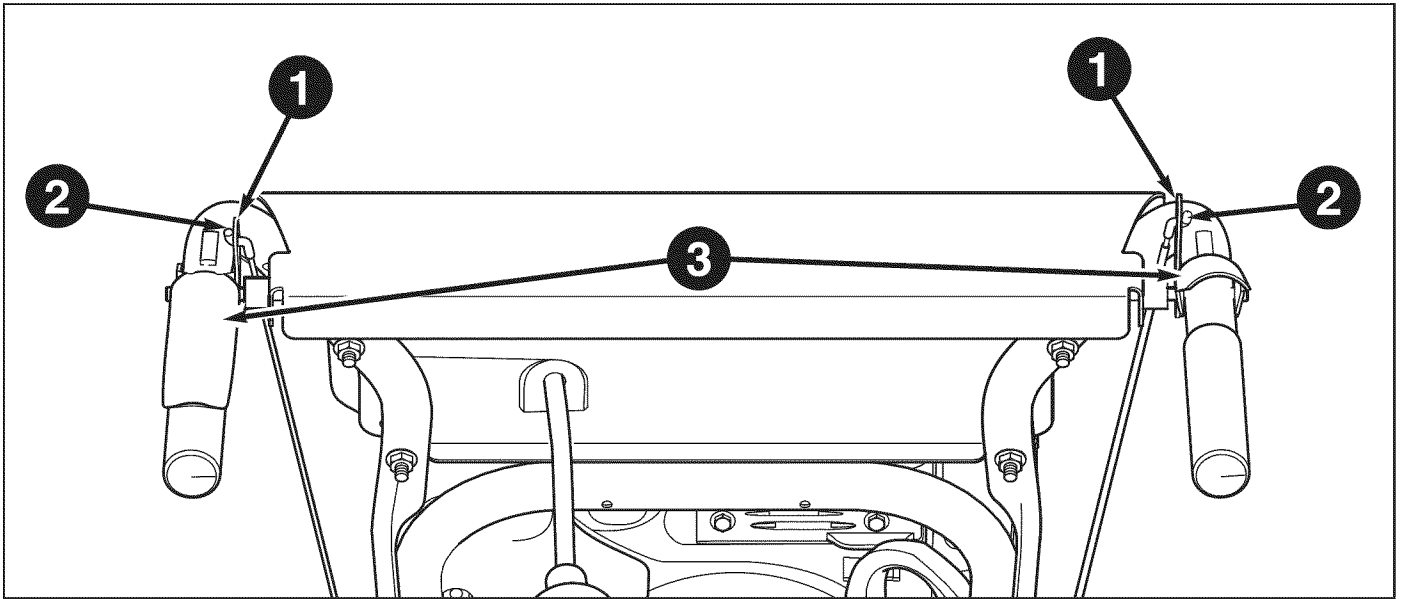

8

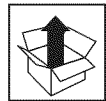

9

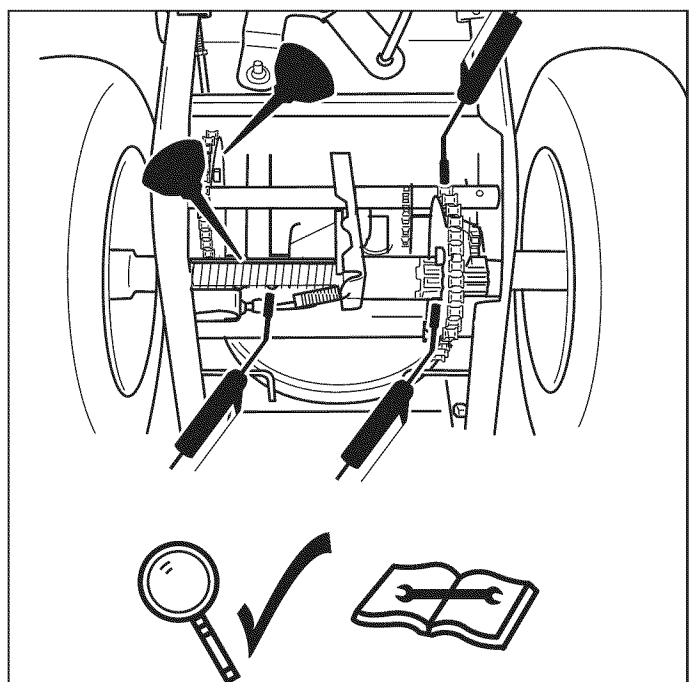
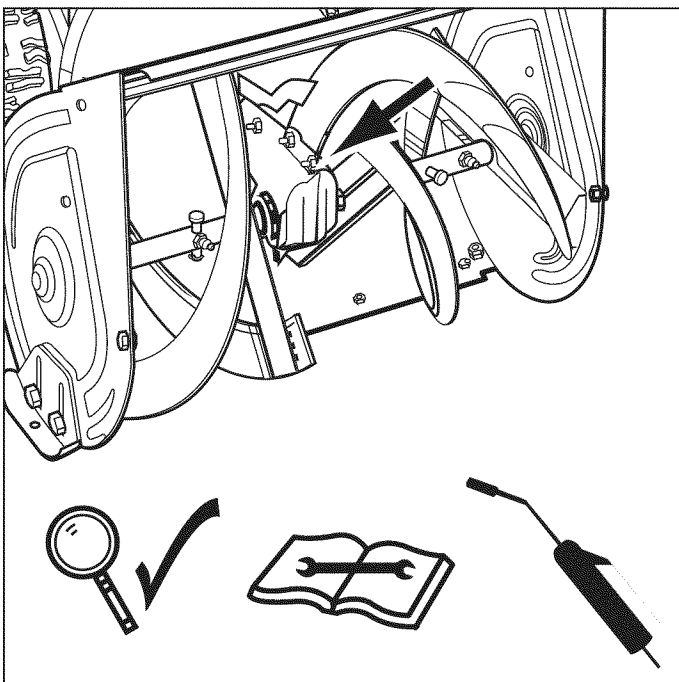



10

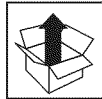
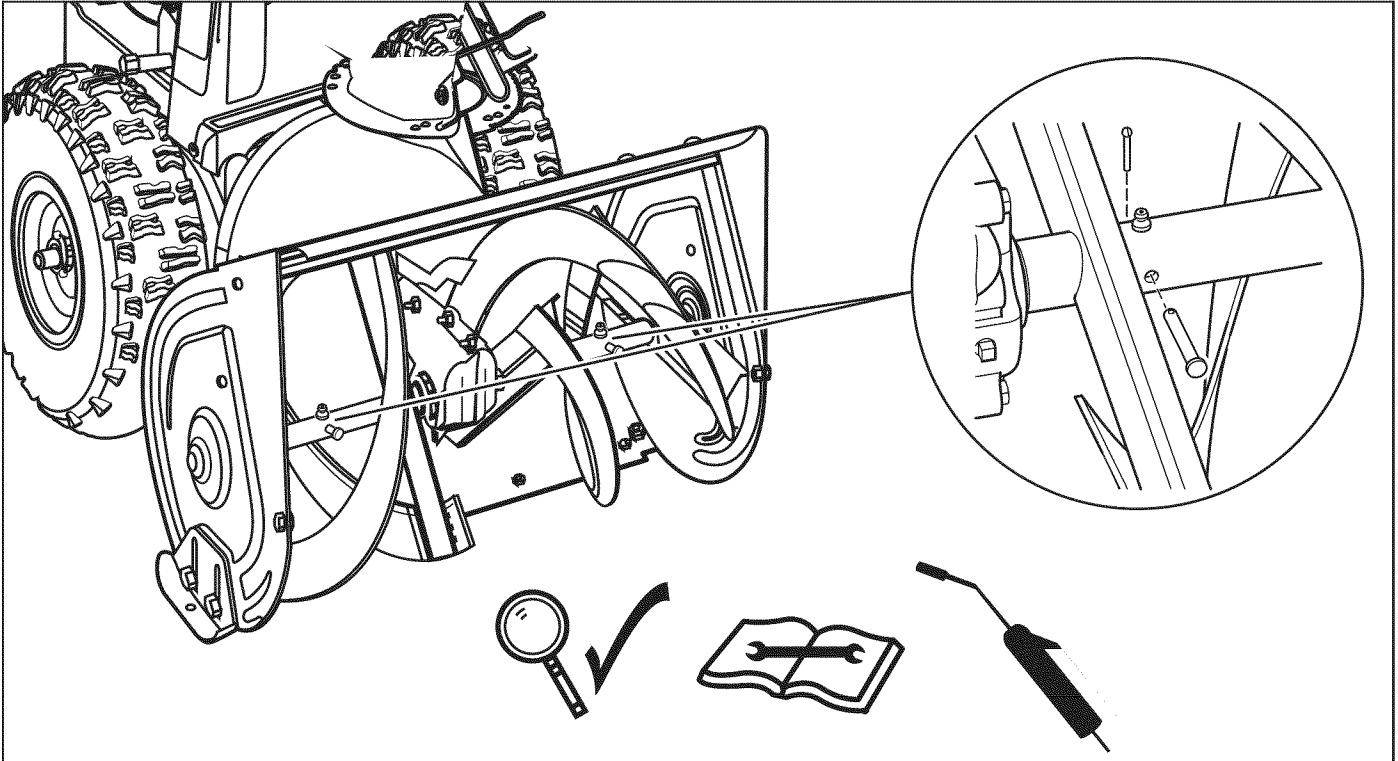

11

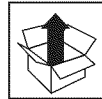
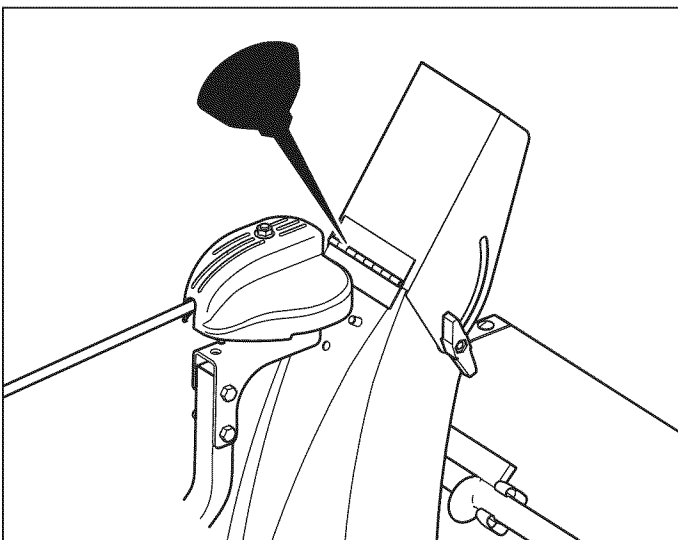

12

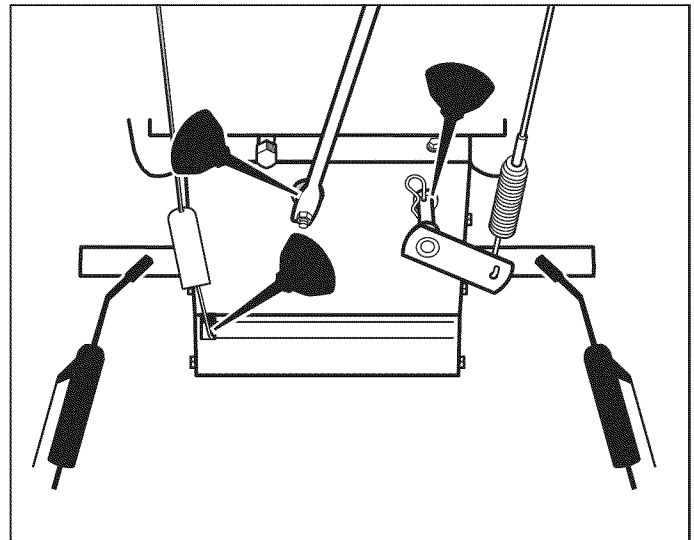



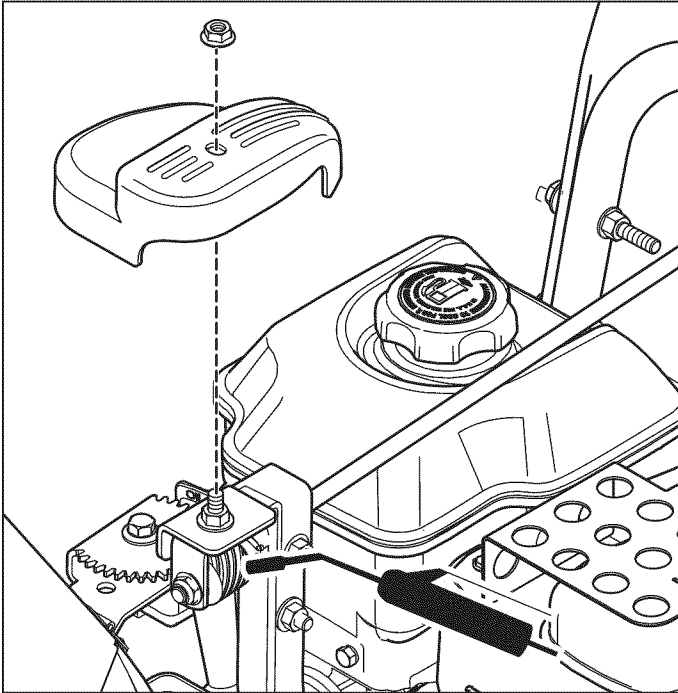

 **13**

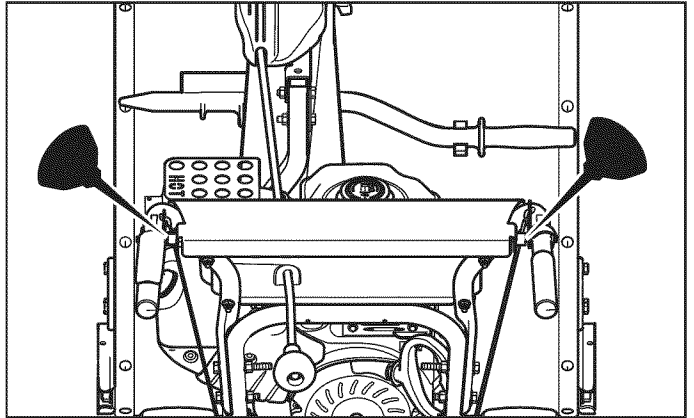

 **14**



 **15**

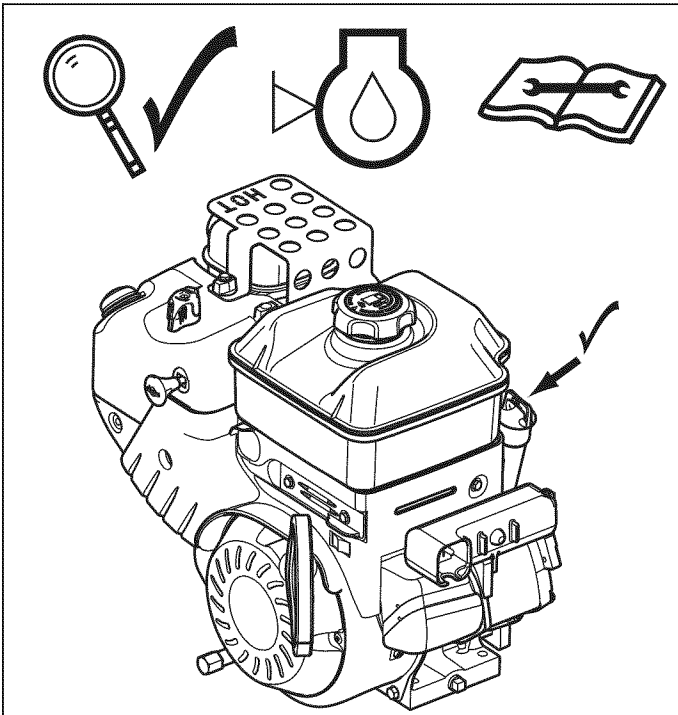

 **16**

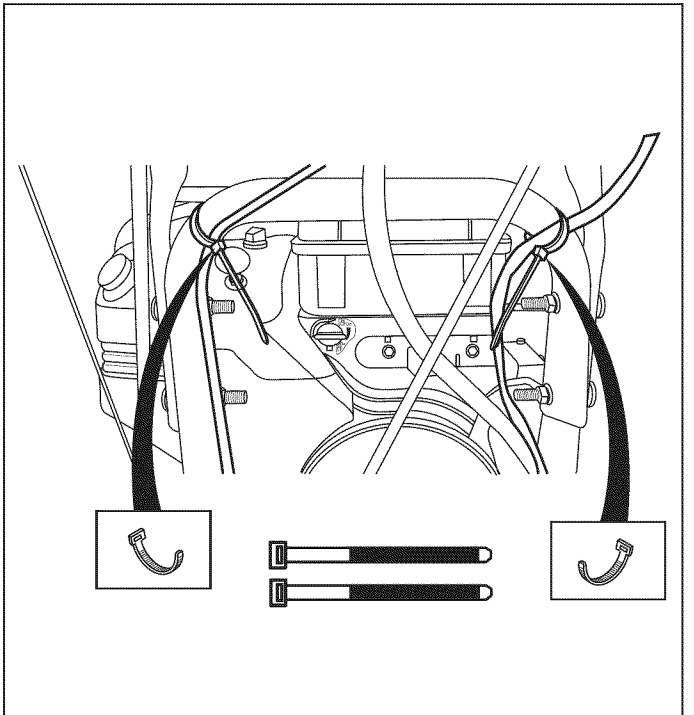

### Setup



## Perform Safety Checks

### Check Engine Controls

1. Make sure all safety guards are in place and all nuts, bolts, clips, cotter pins and wires are secure.
2. Check to make sure spark plug wire is attached.
3. Check all controls for proper operation:
  - a. The engine should stop when the key is removed.
  - b. The throttle should control the engine speed and stop the engine when moved to the STOP position.
  - c. The fuel shut-off valve should stop the flow of fuel to the engine
  - d. The recoil starter or electric starter (if equipped) should crank the engine when activated.
4. Check the engine area for oil or gasoline leaks. Correct any problems in accordance with the engine manufacturers instructions.

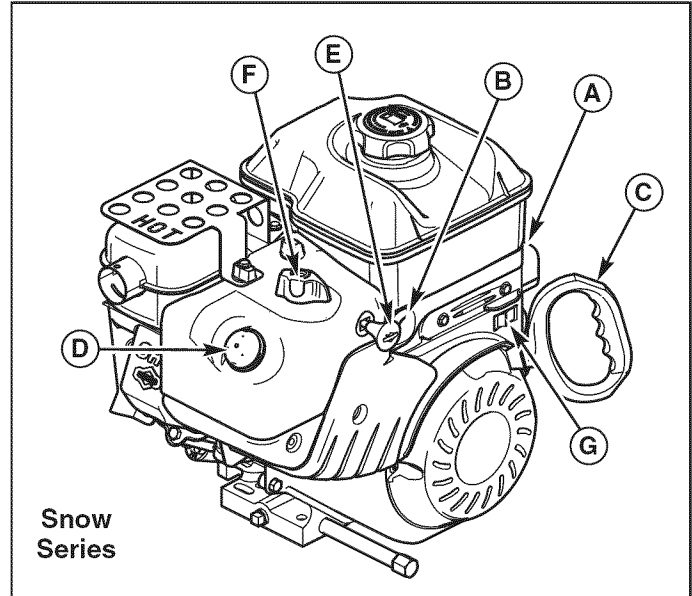

**Figure 1. Engine Controls**

- A. Electric Start Button (Select Models)**
- B. Fuel Valve (Select Models)**
- C. Starter Handle**
- D. Primer Button**
- E. Engine Key**
- F. Choke Knob**
- G. Stop Switch**

**Setup**

## Perform Safety Checks

### Check Snowthrower Controls

1. Check the skid shoes to make sure they are set at the desired height. Adjust if necessary.
2. Check the traction drive control (B, Figure 2). Snowthrower motion should stop when the control is released.
3. Check the auger control (C). Auger movement should stop when the control is released.
4. Check the manual chute direction control (D) for proper operation. The discharge chute should rotate freely in both directions.
5. Check the deflector for proper operation. The deflector should pivot freely up and down when the chute deflector knob (E) is loosened.
6. Check the speed selector (A) for smooth operation. The control must move freely into each speed position gate and remain in position when released.

**If controls do not function properly, perform the appropriate adjustment as shown in the Adjustment Section.**

7. The auger is secured to the shaft by shear pins, which will break if the auger strikes an object. Extra shear pins are provided. Keep these pins in the compartment on the belt cover. Lubricate the auger shaft.

### Check Operations

1. With engine at full speed, engage the auger control and release. Do this ten (10) times. **Auger should come to a complete stop within five seconds each time.** If not, perform Auger Adjustments.
3. Engage traction control and release. Do this ten times. Unit should come to a complete stop each time. If it does not, perform the Traction Drive Adjustments.
4. Remove the engine key. The engine must stop.
5. Move the throttle to STOP. The engine must stop.

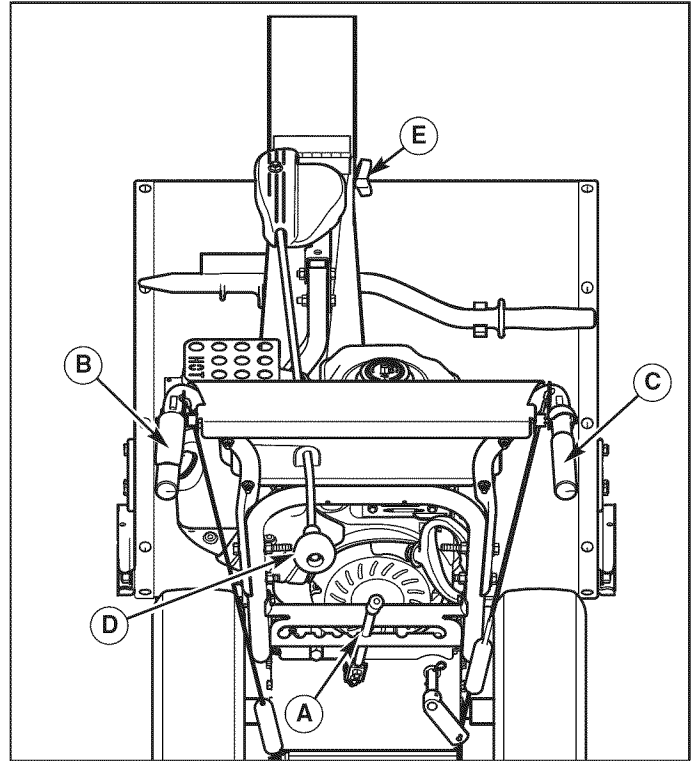

**Figure 2. Controls (from operator's position)**

- A. Speed Selector**
- B. Traction Control**
- C. Auger Engage Control**
- D. Chute Rotator Control**
- E. Deflector Control**



### Auger Drive Adjustment

#### WARNING

Do not over-tighten, as this may lift the lever and cause auger drive to be engaged without depressing the Auger Control.

1. With the drive lever released, the hook (B, Figure 3) should barely touch the lever (C) without raising it. There can be a maximum 1/32" clearance as shown.
2. To adjust, loosen nut (D) by holding the adjusting flats (A) and turning nut (D). Turn adjustment flats and hold screw. The adjustment screw (E) is a phillips screw and the head can be held or turned by inserting a screwdriver through the spring (F).
3. Hold adjusting flats (A) and tighten nut (D).
4. Start unit and check auger. Auger must not be engaged unless auger control is depressed.
5. With engine running, fully depress auger control, the auger should engage and run normally.
6. Release auger control. **Auger must stop within 5 seconds.**
7. If auger does not operate properly, stop engine and recheck drive linkage adjustments.
8. If auger linkage is properly adjusted, auger drive belt tension may require adjustment. See adjusting the auger belt in this section of the manual

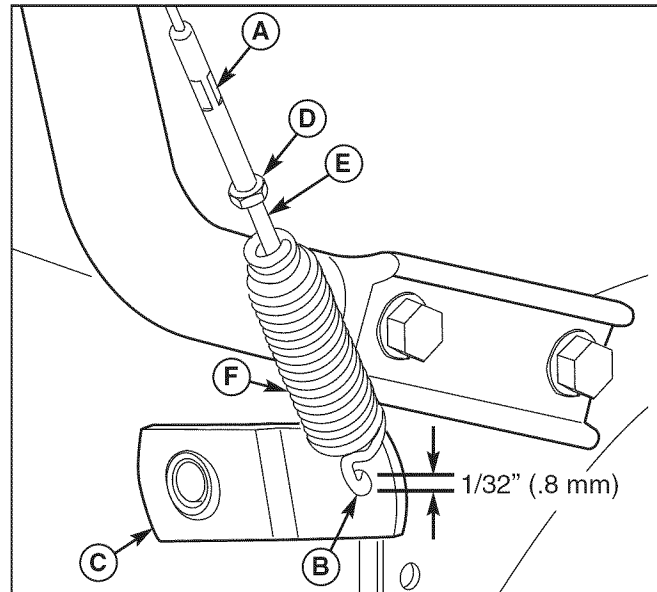

**Figure 3. Auger Drive Adjustment**

- A. Adjusting Flats**
- B. Spring Hook**
- C. Lever**
- D. Adjustment Nut**
- E. Adjustment Screw**
- F. Spring**

## **⚠ WARNING**

Do not over-tighten, as this may cause traction drive to engage without depressing the traction drive control (arm must remain in down position).

Verify that the cables are not over-tightened: With speed selector in position 1 and traction drive control fully released, push snowthrower forward. The unit should move forward freely.

If unit does not move forward freely, the cable has been over-tightened. To remedy, loosen tension on clutch cable slightly, and recheck.

## TRACTION DRIVE ADJUSTMENT

### Initial Adjustment

1. With the drive lever released there should be slack in the cable when moved slightly from side to side.
2. To adjust tension on the cable slide the cable boot (A, Figure 4) off the cable adjustment bracket (D).
3. Move the "Z" hook (C) from the cable adjustment bracket (D) to a different adjustment hole. The cable should have slack. The cable should have no tension or load.

*Note: If the cable is too slack the unit will not drive. If the cable is too tight the drive will be engaged without pushing the handle down.*

4. Slide the cable boot (A) over the cable adjustment bracket.

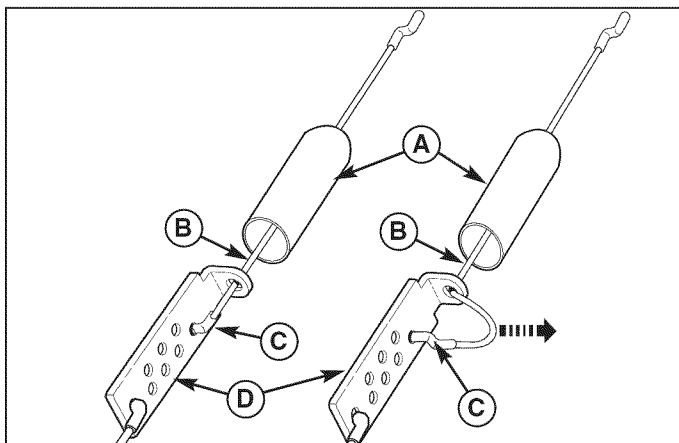

**Figure 4. Traction Drive Cable Adjustment**

- A. Cable Boot
- B. Traction Drive Cable
- C. "Z" Hook
- D. Cable Adjustment Bracket

## Run-In Adjustment

### ALL MODELS

1. After 5 hours of use, check for proper adjustment. Readjust clutch cable if necessary by increasing tension on cable. A small amount of arm movement is permissible if unit passes operating checks described in the Warning above.

## **⚠ WARNING**

Gasoline is highly flammable and must be handled with care. Drain gasoline outdoors. Never drain the tank when the engine is still hot from recent operation. Do not allow open flame, smoking or matches in the area. Avoid over-filling and wipe up any spills.

2. Remove the gas from the gas tank.
3. Disconnect the spark plug wire.
4. Stand snowthrower on the front of the auger housing (C, Figure 5).
5. Remove the capscrews (A) on each side of the bottom panel (B).
6. Remove the bottom panel (B).

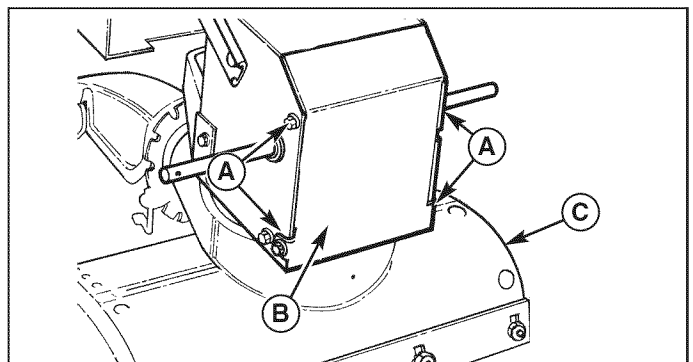
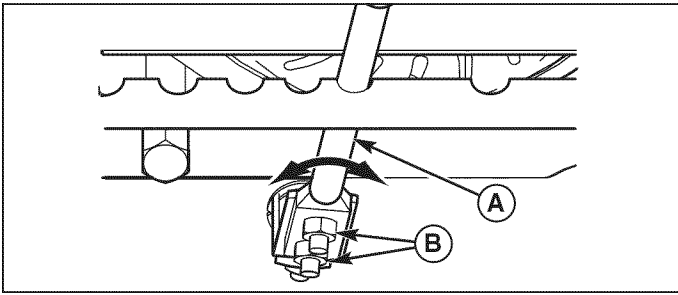

**Figure 5. Bottom Cover**

- A. Capscrews
- B. Bottom Panel
- C. Auger Housing

## Intermediate Frame Snowthrowers

- Loosen shift lever nuts (B, Figure 6), and position the shift speed lever (A) in the lowest forward speed.



**Figure 6. Shift Lever Adjustment**

- A. Shift Lever**
- B. Nuts, 1/4-20**

- Note the position of the friction wheel (A, Figure 7). The correct distance from the right side of the friction wheel to the outside of the frame is 4-5/16" (10.95 cm). If the friction wheel is not in the correct position, adjust as follows.
- Move the friction wheel (A, Figure 7) to the correct distance, 4-5/16" (10.95 cm).
- Tighten the 1/4-20 shift lever nuts (B, Figure 6) to 60 lb-in. (6,8 Nm).
- Check that the snowthrower operates in R1. If not follow procedures 1-10 and readjust as necessary.
- Install the bottom panel (B, Figure 5) and tighten the capscrews (A).

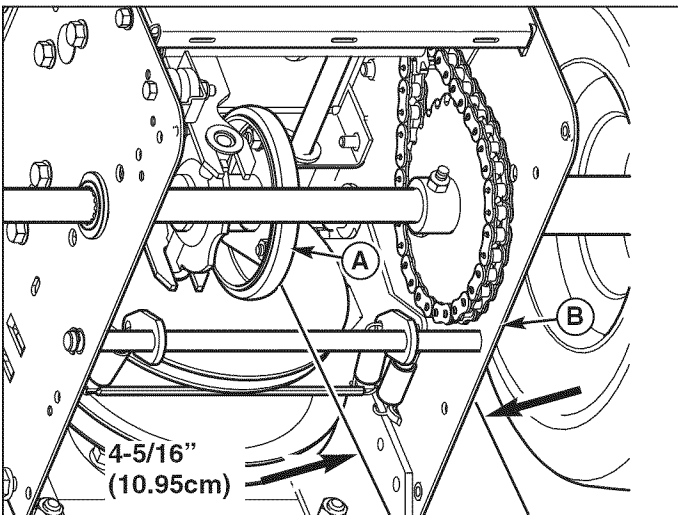

**Figure 7. Friction Disc Measurement**

- A. Friction Wheel**
- B. Frame**



## Scraper Bar & Skid Shoe Adjustment

On smooth surfaces such as concrete or asphalt, the scraper bar should scrape the surface. On surfaces such as gravel, the scraper bar should be high enough so that it will not pick up gravel or debris.

The height of the scraper bar is controlled by raising or lowering the Skid Shoes (See Figure 8).

- To raise the scraper bar height, rest the scraper bar on a strip of wood equal in thickness to the desired height.
- Make sure the scraper bar is parallel to the ground surface.
- Loosen the skid shoe nuts and let the skid shoes drop to the surface.
- Tighten the nuts, making sure the Skid Shoes are adjusted equally and are parallel to the surface.
- To lower the height of the scraper bar, raise the Skid Shoes.
- If the scraper bar becomes worn, it can be adjusted by loosening the nuts and bolts attaching it to the snowthrower, making the adjustment, and tightening the hardware. It may also be replaced by removing the mounting nuts and bolts attaching it to the snowthrower.

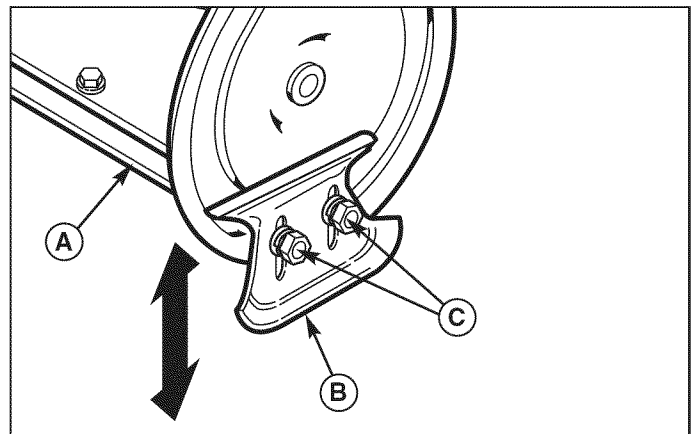

**Figure 8. Skid Shoe Adjustment**

- A. Scraper Bar**
- B. Skid Shoe**
- C. Nuts**



## Belt Adjustment

### Auger Drive Belt

If your snowthrower will not discharge snow, check the control cable adjustment. If it is correct, then check the condition of the auger drive belt. If it is damaged or loose, replace it (see Belt Replacement in this section of the manual).

1. Disconnect spark plug wire.
2. Loosen screw (B, Figure 9) from belt cover (A). Remove belt cover (A).
3. Loosen nut (D, Figure 10) on auger idler pulley (B) and move auger idler pulley towards belt about 1/8 inch (3mm).
4. Tighten nut (D).
5. Engage auger drive clutch. Check tension on belt (opposite idler pulley). Belt should deflect about 1/2 inch (12.5 mm) with moderate pressure see Figure 11). You may have to move the idler pulley more than once to obtain the correct tension.
6. Reinstall belt cover (A, Figure 9) securing with screws (B).
7. Whenever belts are adjusted or replaced, the auger drive or traction drive controls will need to be adjusted. (see Auger Drive or Traction Drive Adjustment in this section of the manual).
8. Attach the spark plug wire.
9. Auger must stop within 5 seconds.

### Traction Drive Belt

The traction drive belt has constant spring pressure and does not require an adjustment. If the traction drive belt is slipping, replace the belt. See Belt Replacement.

*Note: After adjustments are complete, make sure the drive disengages when released.*

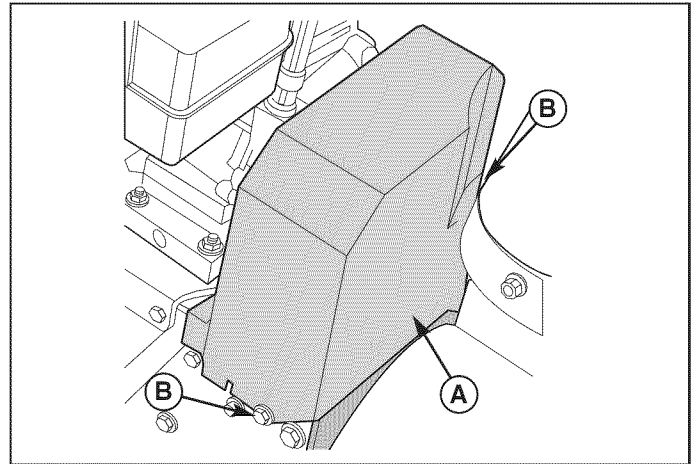

**Figure 9. Belt Cover**  
A. Belt Cover  
B. Screws

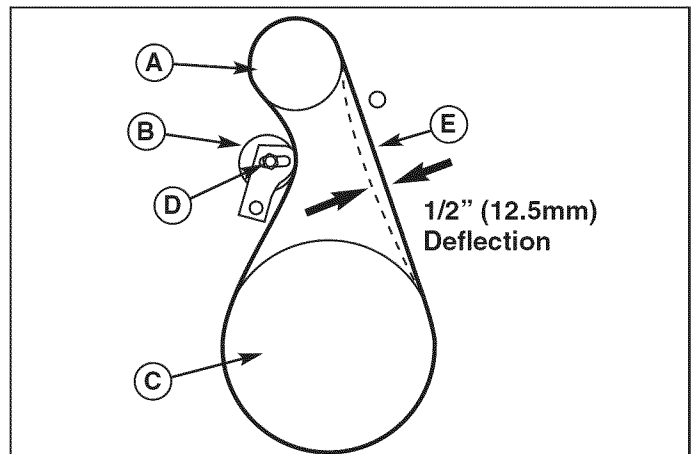

**Figure 10. Auger Belt Deflection**  
A. Engine Drive Pulley  
B. Idler Pulley (Engaged Position)  
C. Auger Drive Pulley  
D. Nut  
E. Auger Belt



## Belt Replacement

### Auger Drive Belt

The drive belts are of special construction and must be replaced with original factory replacement belts available from your nearest authorized service center. Some steps require the assistance of a second person. If the auger drive belt is damaged, the snow thrower will not discharge snow. Replace the damaged belt as follows.

1. Disconnect the spark plug wire.
2. Loosen the capscrews (A, Figure 11) on each side of the bottom panel (B).
3. Remove the bottom panel (B).

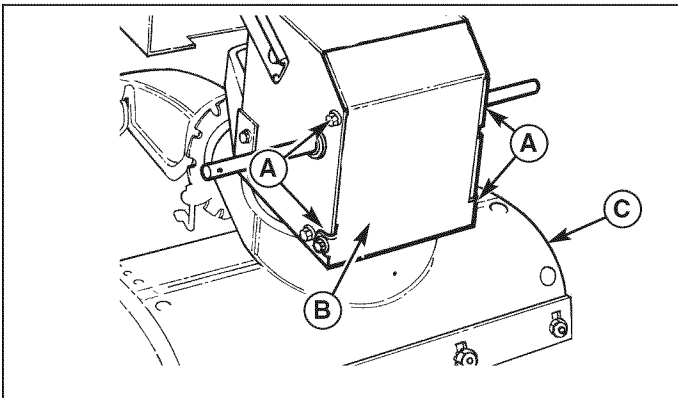

Figure 11. Bottom Cover

- A. Capscrews
- B. Bottom Panel
- C. Auger Housing

4. Loosen screw (B, Figure 8) from belt cover (A). Remove belt cover (A).
5. Loosen the belt guide (B, Figure 12). Pull the belt guide away from the auger drive pulley (A).
6. Pull the auger idler pulley (K) away from the auger drive belt (D) and slip the belt off of the idler.
7. Remove the auger drive belt (D) from the engine pulley. To remove the auger drive belt (D), the auger drive pulley (C) may have to be partially rotated.

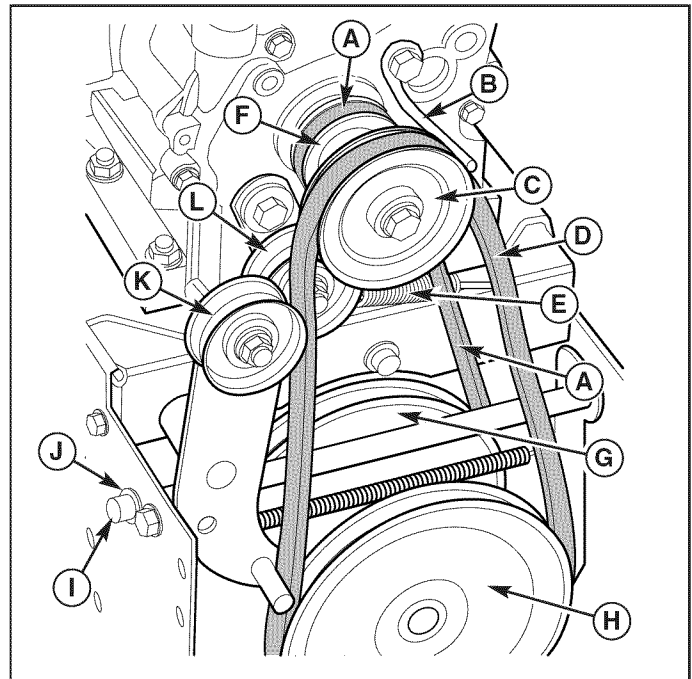

Figure 12. Pulleys and Belts

- A. Traction Drive Belt
- B. Belt Guide
- C. Auger Drive Pulley, Engine
- D. Auger Drive Belt
- E. Traction Drive Spring
- F. Traction Drive Pulley, Engine
- G. Traction Drive Pulley
- H. Impeller Pulley
- I. Swing Plate Axle Rod
- J. "E"-Ring
- K. Auger Idler Pulley
- L. Traction Drive Idler Pulley

8. Remove the 5/16 flange lock nut (B, Figure 13) securing the rotator cover (A).

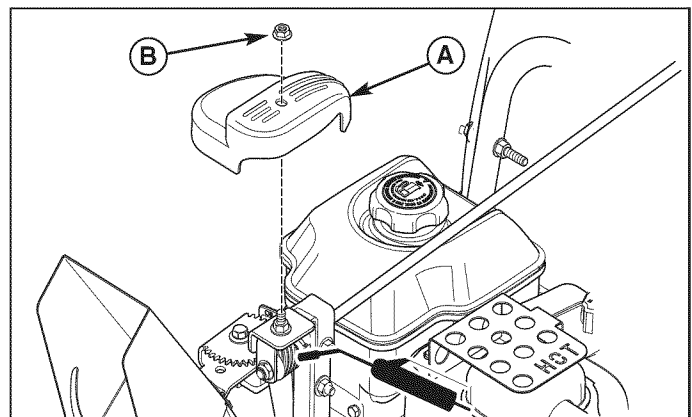
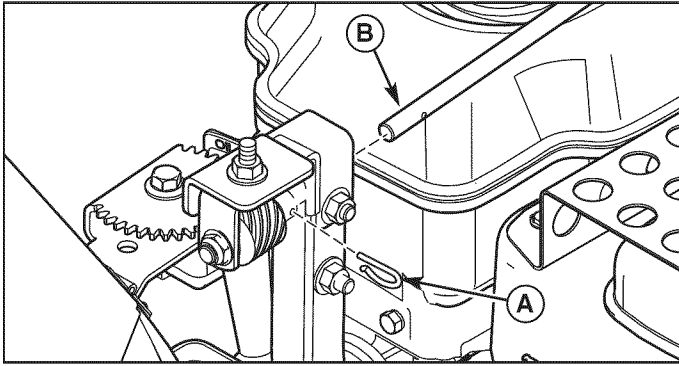

Figure 13. Rotator Cover Removal

- A. Cover
- B. Nut, flange, lock 5/16-18





**Figure 14. Rotator Shaft Removal**

- A. Pin, Hair
- B. Shaft

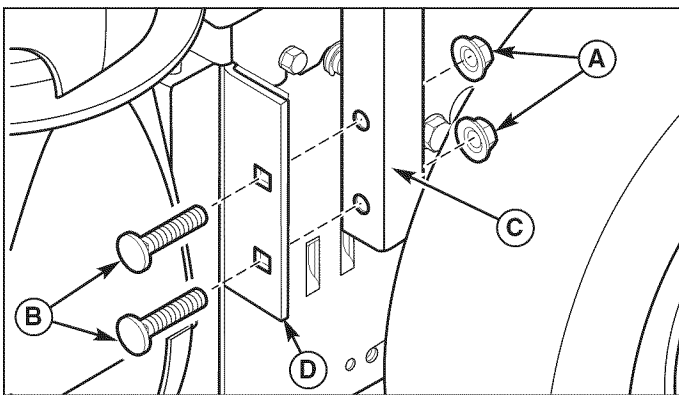

**Figure 15. Offset Tube (Lower) Removal**

- A. Nuts, KEPS, hex, 5/16-18
- B. Bolts, Carriage, 5/16 x 1-1/2
- C. Tube, Offset
- D. Bracket, tube support

9. Remove hair pin (A, Figure 14) and slide rod (B) backward about 3 inches (until shaft separates from the worm drive).
10. Remove two 5/16-18 KEPS hex nuts (A, Figure 15), and two 5/16-18 x 1-1/2 carriage bolts (B) securing the offset tube (C) to the tube support bracket (D).
11. Lift the Chute and rotator (A, Figure 16) off of the auger housing.
12. Remove the upper four capscrews (A, Figure 17) that hold together the auger housing (C) and the frame (D). Loosen the lower two capscrews (B). The auger housing (C) and the frame (D) can now be split apart for removal of the belt.
13. Remove the old auger drive belt (D, Figure 12) from the impeller pulley. Replace the auger drive belt with an original factory replacement belt available from an authorized service center.
14. Install the new auger drive belt (D) onto the impeller pulley.

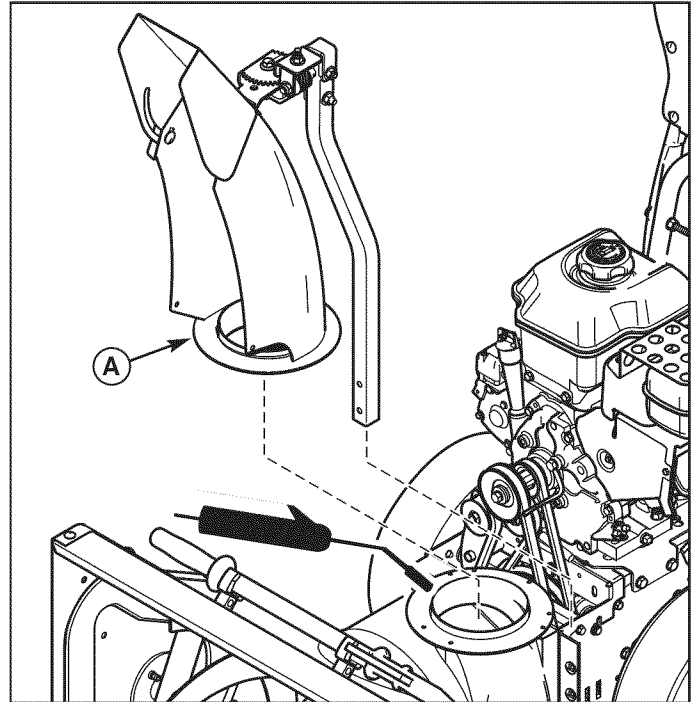

**Figure 16. Chute and Rotator Removal**

- A. Chute and Rotator

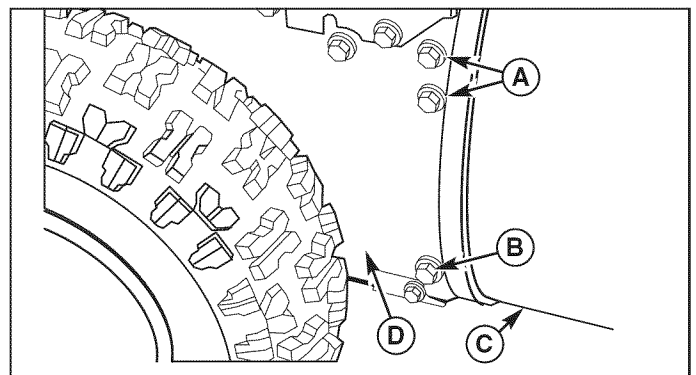
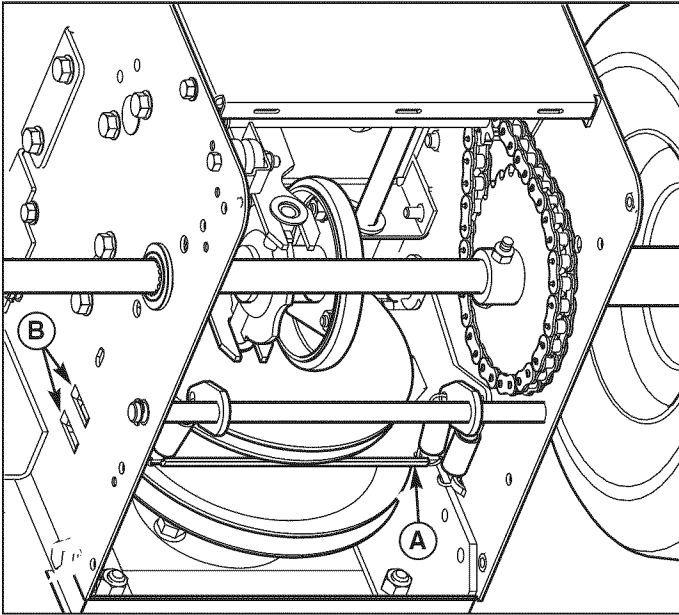

**Figure 17. Frame and Axle Housing Splitting**

- A. Upper Capscrews
- B. Lower Capscrews
- C. Auger Housing
- D. Frame

*NOTE: To assemble the auger housing to the frame, have someone hold the auger clutch lever in the ENGAGED position. This will move the idler arm and pulley enough to allow the auger drive pulley to move back into position.*

15. Assemble the auger housing (C, Figure 17) to the frame with the four upper tapite screws (A) that were removed in step 12. Tighten the two lower tapite screws (B). Tighten all tapite screws to 40-50 lb-in (4,5-5,6 Nm).
16. Attach chute and offset tube previously removed (Figure 15 and 16). Tighten all KEPS nuts to 11 lb-ft (15 Nm).



**Figure 18. Traction Belt Change**

**A. Swing Plate**

**B. Alignment Tabs**

17. Slide spout rotator rod (B, Figure 14) into worm gear, and secure with hair pin (A).
  18. Install rotator cover (A, Figure 13) and secure with 5/16-18 flange lock nut (B). Tighten nut to 11 lb-ft (15 Nm).
  19. Install the auger drive belt (D, Figure 12) onto the impeller pulley (H).
  20. Slip the auger drive belt (D) under the idler pulley (K).
  21. Adjust the auger drive belt. See "Belt Adjustment: Auger Drive Belt" in the Adjustment section.
  22. Adjust the belt guide. See "Belt Adjustment" in this section.
  23. Install the belt cover (A, Figure 9). Tighten 1/4-20 screws (B) to 25-35 lb-in (2,8-3,9 Nm).
- Note: Caution must be taken when tightening the screws that secure the belt cover. Over tightening the screws will deform the plastic.*
24. Check the adjustment of the cables. See "Adjustments - Auger Drive Adjustment and Traction Drive Cable Adjustment" in the Adjustment section.
  25. Install the bottom panel (B, Figure 11). Tighten 1/4-20 screws to 25-35 lb-in (2,8-3,9 Nm).
  26. Connect the spark plug wire.

### Traction Drive Belt

If the snow thrower will not move forward, check the traction drive belt for wear or damage. If the traction drive belt is worn or damaged, replace the belt as follows.

1. Disconnect the spark plug wire.
  2. Remove the auger drive belt. See "Belt Replacement" in this section.
  3. Remove the traction drive spring (E, Figure 12).
  4. Remove the e-ring (J, Figure 12) from one end of the swing plate axle rod (I).
  5. Remove the swing plate axle rod (I) to allow the swing plate (A, Figure 12) to pivot forward.
  6. Remove the old traction drive belt (A) from the traction drive pulley (G) and from the traction drive pulley (F). Replace the traction drive belt (A) with an original factory replacement belt available from an authorized Dealer.
  7. Install the new traction drive belt (A) onto the traction drive pulley (G) and onto traction drive pulley (F).
  8. Make sure the traction drive idler pulley (L) is properly aligned with the traction drive belt (A).
  9. Install the swing plate axle rod (I) and secure with the e-ring (J) removed earlier.
  10. The bottom of the swing plate (A, Figure 18) must be positioned between the alignment tabs (B). Make sure the swing plate is properly secured.
- NOTE: If the drive will not engage after the traction drive belt has been replaced, then check to make sure that the swing plate is positioned between the alignment tabs.*
11. Attach the traction drive spring (E, Figure 12).
  12. Install and adjust the auger drive belt. See Belt Replacement in this section of the manual.
  13. Adjust the belt guide. See Belt Adjustment in this section of the manual.
  14. Install the bottom panel (B, Figure 11). Tighten 1/4-20 screws to 25-35 lb-in (2,8-3,9 Nm).
  15. Install the belt cover (A, Figure 9). Tighten 1/4-20 screws (B) to 25-35 lb-in (2,8-3,9 Nm).
- Note: Caution must be taken when tightening the screws that secure the belt cover. Over tightening the screws will deform the plastic.*
16. Check the adjustment of the cables. See Adjustments in this section of the manual.
  17. Connect the spark plug wire.