

Safety Instructions & Operator's Manual for **SNAPPER**[®]

L.E. SINGLE STAGE SMALL FRAME SNOW THROWER SERIES 1

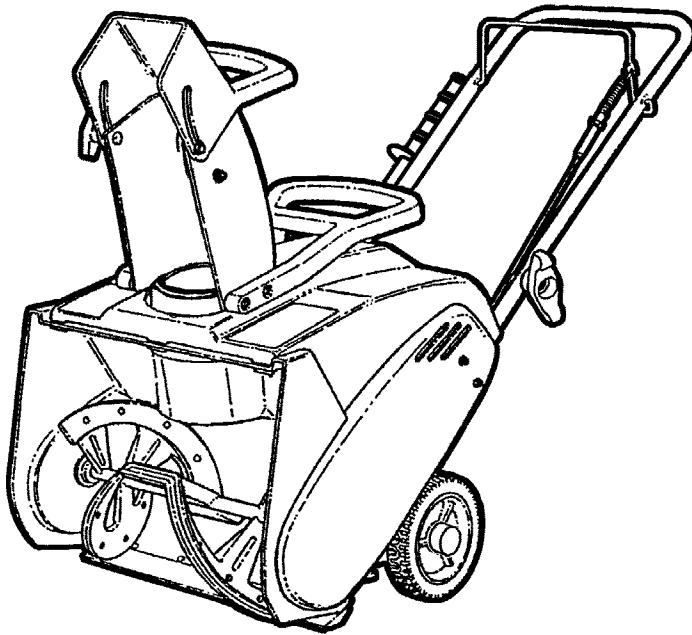

MODELS
LE3171R
LE3191R
LE3191E

MODEL NUMBER EXPLANATION

L E 3 19 1 E

MODEL DESIGNATION
ENGINE POWER *

ENGINE OPTIONS
SERIES DESIGNATION
AUGER WIDTH

L – Light Weight Frame	17 – 17” Auger Width	1 -- Series Designation
E – Easy Operation	19 – 19” Auger Width	E – 110 Volt Electric Start
3 – 3.0 (Engine Power *)		R – Recoil Start

Thank you for buying a SNAPPER Product! Before operating your Snow Thrower, read this manual carefully and pay particular attention to the “IMPORTANT SAFETY INSTRUCTIONS” on Pages 2 - 4. Remember that all power equipment can be dangerous if used improperly. Also keep in mind that SAFETY requires careful use in accordance with the operating instructions and common sense.

* Actual sustained engine power will likely be lower due to operating limitations and environmental factors. See POWER RATINGS on Page 5 for further information.

SNAPPER®McDonough, GA., 30253 U.S.A.

COPYRIGHT © 2006
SNAPPER – A DIVISION OF SIMPLICITY MFG., INC.
ALL RIGHTS RESERVED

INSTRUCTION No. 7100947 (I.R. 6/26/2006)
TP 100-5205-00-SX-SN



IMPORTANT SAFETY INSTRUCTIONS



WARNING: This powerful machine is capable of amputating hands and feet and can throw objects that can cause injury and damage! Failure to comply with the following instructions may result in serious injury to the operator or other persons. The owner of the snow thrower must understand these instructions and, furthermore, must allow only persons who understand these instructions to operate snow thrower. Each person operating the snow thrower must be of sound mind and body and must not be under the influence of any substance, which might impair vision, dexterity, or judgment. If you have any questions pertaining to your snow thrower which your dealer cannot answer to your satisfaction, call or write the Customer Service Department at SNAPPER, McDonough, Georgia 30253. Phone: 800/935-2967.

PROTECTION FOR CHILDREN

Tragic accidents can occur if the operator is not alert to the presence of children. Children are often attracted to the machine and the snow removal activity. Never assume that the children will remain where you last saw them.

1. **DO NOT** allow children in the area when snow thrower is being operated.
2. **DO NOT** allow pre-teenage children to operate snow thrower.
3. **ALLOW** only responsible adults and teenagers with mature judgment to operate the machine and then only after being thoroughly instructed and under the close supervision of an experienced adult operator.
4. Keep the area clear of all persons, particularly small children and pets.
5. Know how to **STOP** the snow thrower and disengage the controls quickly.

PREPARATION

1. Warn everyone in advance to stay clear of area. Keep especially watchful for children and pets darting into area while operating.
2. Read, understand, and follow instructions and warnings in this manual and on the machine. Know the controls and the proper use of the snow thrower before starting.
3. Data indicates that operators, age 60 and above, are involved in a large percentage of snow thrower-related injuries. These operators should evaluate their ability to operate the snow thrower safely enough to protect themselves and others from serious injury.
4. Disengage all clutches and shift into neutral before starting the engine (motor).
5. Wear adequate winter clothing including boots which will give you maximum footing on slippery surfaces. Exercise **CAUTION** to avoid slipping or falling.
6. **DO NOT** wear loose fitting clothing that can get caught in moving parts.
7. Before the first snow fall, check the area to be cleared and remove all objects such as doormats, sticks, toys, wires, rocks, etc., which could be hurled or jam the snow thrower.

PREPARATION

8. Survey the area to be cleared beforehand and plan where snow is to be blown. Be prepared to release auger/impeller clutch or to change discharge chute direction quickly to discharge away from windows, cars, buildings and doorways to avoid property damage or personal injury from hurled objects.
9. Use only approved extension cords and receptacles in good condition and with sufficient capacity to carry the current to the machine if equipped with electric starting motors.
10. Handle fuel with extra care. Fuels are flammable and vapors are explosive. Store only in an approved fuel container. Never remove fuel cap or add fuel with the engine running. Add fuel outdoors only with the engine stopped and cool. Clean spilled fuel and oil from machine. **DO NOT** smoke. **DO NOT** run engine indoors.

OPERATIONAL PRECAUTIONS

1. Before starting, make visual check to make sure auger/impeller housing is clear and all guards and shields are in place and tight.
2. **DO NOT** operate machine without proper guards shields, deflectors, or other safety protective devices in place and functioning properly.
3. Should the auger/impeller become clogged, release the auger/impeller clutch control and, as an additional precaution, **STOP** the engine before attempting to unclog the auger/impeller or discharge chute.
4. **DO NOT** attempt to unclog the auger/impeller or discharge chute by reaching in with your hands. Use the clean-out tool or similar implement to unclog.
5. **DO NOT** attempt to unclog the auger/impeller or discharge chute with the engine running. **STOP** engine and remove key. Wait for all motion to **STOP**.
6. **STOP** engine (motor) and remove key before leaving the operator position for any reason. **DO NOT** put hands or feet near or under rotating parts. Keep clear of the discharge opening at all times.



IMPORTANT SAFETY INSTRUCTIONS



OPERATIONAL PRECAUTIONS

7. Start engine only where exhaust fumes will be safely dissipated. Allow a brief warm-up period, and practice operation of controls outside before putting the machine to work.
8. After striking a foreign object, STOP the engine (motor), remove the key, and remove the wire from spark plug. Thoroughly inspect the snow thrower for any damage, and repair the damage before restarting and operating the snow thrower.
9. STOP the engine if the machine starts to vibrate excessively as this normally indicates mechanical problems. Remove the key and disconnect the spark plug wire to prevent unintentional starting before servicing or repairing the machine.
10. Exercise extreme CAUTION when operating on slopes.
11. DO NOT clear snow across the face of slopes. Exercise extreme CAUTION when changing direction on slopes. DO NOT attempt to clear steep slopes.
12. DO NOT leave machine unattended with the engine running. STOP engine and remove key to prevent unauthorized operation.
13. Release clutch control and make sure auger/impeller has STOPPED before rotating discharge chute, adjusting deflector, or placing hands near auger/impeller.
14. DO NOT use snow thrower on surfaces above ground level, such as, a roof of a building.
15. DO NOT direct the discharge toward people or areas where property damage can occur. Keep children and others away.
16. Exercise extreme CAUTION when operating on or crossing gravel drives, walks, or roads. Stay alert for hidden hazards or traffic.
17. DO NOT overload the machine capacity by attempting to clear snow at too fast a rate.
18. Never operate the machine at high transport speeds on slippery surfaces. Look behind and use care when backing.
19. Disengage power to the auger/impeller when snow thrower is transported or not in use.
20. Use only attachments and accessories approved by the manufacturer of the snow thrower (such as wheels weights, counterweights, cabs and the like).
21. Never operate the snow thrower without good visibility or light. Always be sure of your footing, and keep a firm hold on the handles. Walk; never run.
22. DO NOT touch a hot engine or muffler.

CLEARING A CLOGGED DISCHARGE CHUTE

Hand contact with the rotating auger/impeller inside the discharge chute is the most common cause of injury associated with snow throwers. DO NOT use your hand to clean out the discharge chute. To clear the chute:

1. STOP the engine. Remove the key.
2. Wait 10 seconds to be sure the auger/impeller blades have stopped rotating.
3. Always use the clean-out tool. DO NOT use your hands.

SAFE HANDLING OF GASOLINE

To avoid personal injury or property damage, use extreme care in handling gasoline. Gasoline is extremely flammable and the vapors are explosive

1. Extinguish all cigarettes, cigars, pipes and other sources of ignition.
2. Use only an approved fuel container.
3. DO NOT remove fuel cap or add fuel with the engine running. Allow the engine to cool before refueling.
4. DO NOT refuel the machine indoors.
5. DO NOT store the machine or fuel container inside where there is an open flame, spark or pilot light such as on a water heater or other appliances.
6. DO NOT fill fuel containers inside a vehicle or on a truck or trailer bed with a plastic liner. Always place the containers on the ground away from the vehicle before filling.
7. Remove gas-powered equipment from the vehicle or trailer and refuel it on the ground. If this is not possible, then refuel equipment using a portable container, rather than a gasoline dispenser nozzle.
8. DO NOT start gas powered equipment in enclosed vehicles or trailers.
9. Keep the nozzle in contact with the rim of the fuel tank or container opening at all times until fueling is complete. DO NOT use a nozzle lock-open device
10. If fuel is spilled on clothing, change clothing immediately.
11. DO NOT overfill a fuel tank. Replace fuel cap and tighten securely.



IMPORTANT SAFETY INSTRUCTIONS



MAINTENANCE AND STORAGE

1. **DO NOT** store machine or fuel container inside where fumes may reach an open flame, spark, or pilot light as in a water heater, furnace, clothes dryer or other gas appliance. Allow engine to cool before storing machine in an enclosure. Store fuel container out of reach of children in a well ventilated, unoccupied building.
2. Keep machine and engine free of excess oil, grease and spilled fuel to reduce fire hazard.
3. When draining fuel tank, drain fuel into an approved container outdoors and away from open flame.
4. Inspect all bolts, nuts and screws frequently and keep properly tightened.
5. Use only recommended shear bolts (if equipped) to prevent possible damage to machine.
6. Service engine and make adjustments only when engine is stopped. Remove key, remove wire from spark plug, secure wire away from plug, and disconnect cord from electric starting motors to prevent accidental starting.
7. **DO NOT** change engine governor speed settings or overspeed engine.
8. **DO NOT** test for spark by grounding the spark plug next to spark plug hole. Spark from the plug could ignite gas exiting engine.
9. Have machine serviced by an authorized SNAPPER dealer at least once a year and have the dealer install any new safety devices.
10. Maintain safety and instruction labels as necessary.
11. Use only genuine SNAPPER replacement parts to assure that original standards are maintained.

NOTE: Specifications are correct at time of printing and are subject to change without notice.

TABLE OF CONTENTS

SECTION 1 - IMPORTANT SAFETY INSTRUCTIONS	2-4
TABLE OF CONTENTS.....	5
SECTION 2 - OPERATING INSTRUCTIONS	6-10
Pre-start Checklist	6-7
Starting & Stopping Engine (Recoil Start Models).....	8-9
Starting & Stopping Engine (Electric Start Models)	9-10
Starting & Stopping Auger	9-10
SECTION 3 - MAINTENANCE INSTRUCTIONS	11
Checking Auger Drive Belt	11
Checking Auger Flite Shoes.....	11
Checking Clutch Control Cable	11
Annually – End of Each Season.....	11
Engine	11
Spark Plug	11
Storage Procedure	11
SECTION 4 - REPAIR AND ADJUSTMENTS	12-14
Auger Drive Belt Adjustment	12-13
Auger Drive Belt Replacement.....	13-14
Auger Flite Shoe Replacement	14
TROUBLESHOOTING	15
SERVICE SCHEDULE	15
Maintenance/Replacement Parts	15
WARRANTY AND PRODUCT REGISTRATION	16-17

Technical Information

Power Ratings

The power rating labels for individual gas engine models are initially developed by starting with SAE (Society of Automotive Engineers) code J1940 (Small Engine Power & Torque Rating Procedure) (Revision 2002-05). The above values may not necessarily represent the maximum gross power output of a gas engine per SAE J1995 Engine Power Test Code -- Gross Power Rating. The maximum gross power output of these gas engines may be significantly higher in accordance with the SAE J1995 standard. Given both the wide array of products on which our engines are placed, and the variety of environmental issues applicable to operating the equipment, it may be that the gas engine you have purchased will not develop the rated power when used in a piece of power equipment (actual "on-site" power). This difference is due to a variety of factors including, but not limited to, the following: differences in altitude, temperature, barometric pressure, humidity, fuel, engine lubrication, maximum governed engine speed, individual engine to engine variability, design of the particular piece of power equipment, the manner in which the gas engine is operated, gas engine run-in to reduce friction and clean out the combustion chambers, adjustments to the valves and carburetor, and other factors. The power ratings may also be adjusted based on comparisons to other similar engines utilized in similar applications, and will therefore not necessarily match the values derived using the foregoing codes.

Section 2 - OPERATING INSTRUCTIONS

2.1 PRE-START CHECK LIST

Make the following checks and perform the service required before each start-up.

2.1.1. Check guards, chutes, deflectors and covers to make sure all are in place and securely tightened.

2.1.2. Check auger control to insure it works freely. See Figure 2.1.

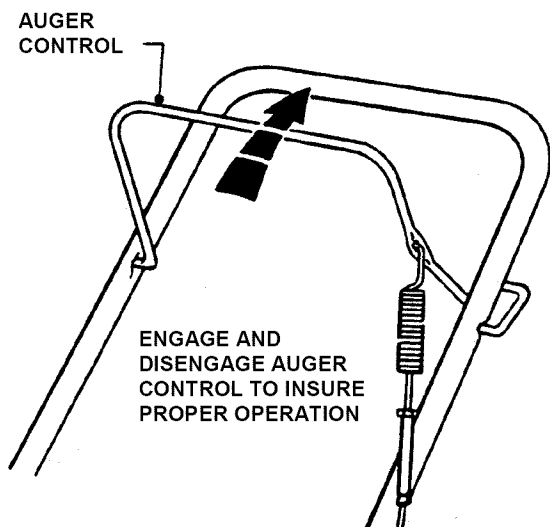

FIGURE 2.1

2.1.3. Check chute operation. Rotate chute to insure smooth rotation throughout its range.

STANDARD FLUID MEASUREMENT (50:1 Ratio)

GASOLINE (Gallons)	2 CYCLE OIL (Ounces)
0.25	.64
0.50	1.3
0.75	1.9
1.00	2.6
1.25	3.2
1.50	3.8
2.00	5.1

METRIC FLUID MEASUREMENT (50:1 Ratio)

GASOLINE (Liters)	2 CYCLE OIL (Cubic Centimeters)
0.50	10
1.00	20
1.50	30
2.00	40
2.50	50
3.00	60
4.00	80

FIGURE 2.2

(Continued on Next Page)

WARNING

Use approved fuel container. **DO NOT** smoke near open fuel container. **DO NOT** fill fuel tank indoors or when engine is running. Allow engine to cool for at least ten minutes before refilling. Wipe off any spilled fuel before starting engine. **DO NOT** run engine indoors.

2.1.4. Mix fresh, good quality unleaded gasoline and SNAPPER 2-cycle engine oil or equivalent. Mix fuel and oil to a 50:1 ratio. See Figure 2.2.

2.1.5. Add premix fuel to tank after pushing the machine outside where fumes can safely dissipate. Make sure cap is tightened after refueling. Refer to Engine Owners Manual for specifications.

2.1.6. Check auger housing, must be free of all obstructions. Clean engine of any accumulation of spilled fuel, dirt, etc.

2.1.7 Make sure the clean-out tool is mounted in the storage position on the snow thrower.

Section 2 - OPERATING INSTRUCTIONS

2.1 PRE-START CHECK LIST

(Continued from Previous Page)

Make the following checks and perform the service required before each start-up.

⚠

DANGER

⚠

DO NOT clean out discharge chute with hands. Contact with moving parts inside chute will cause serious injury. Use clean out tool provided with machine.

⚠

WARNING

⚠

DO NOT use an electrical extension cord that is damaged. A damaged electrical extension cord could cause a shock or fire. Thoroughly inspect electrical extension cord before using machine. If cord is damaged, do not use and do not operate machine. Replace damaged cord immediately. Contact your SNAPPER service dealer for assistance. To reduce the risk of electric shock, use only with an extension cord intended for outdoor use having a cord type: SW-A, SOW-A, STW-A, STOW-A, SJW-A, SJTW-A or SJTOW-A.

2.1.7. Check and make sure extension cord is in good condition. Extension cord should not have any broken insulation or exposed wires. Use an extension cord that is heavy enough to carry the correct amount of current to the machine. See Figure 2.3 for correct size to use depending on cord length and nameplate ampere rating. If in doubt, use the next heavier gauge cord.

MINIMUM GAUGE FOR CORD SETS					
120 Volt		Total Length of Cord in Feet			
Rating - Amps		25 ft.	50 ft.	100 ft.	150 ft.
More Than	Not More Than	A.W.G.			
0	6	18	16	16	14
6	10	18	16	14	12
10	12	16	16	14	12
12	16	14	12	Not Recommended	

FIGURE 2.3

2.1.8. Check the AC electrical outlet that will be used and make sure it is a polarized outlet. The machine has a polarized plug (one blade of plug is wider than the other blade) that will accept a polarized extension cord. The extension cord will fit into a polarized outlet (receptacle) only one way. If plug does not fit fully into your outlet, reverse the plug. If it still does not fit, contact a qualified electrician to install a proper polarized outlet. DO NOT modify or change this polarized plug in any way.

IMPORTANT! Electric Start Kit optional accessory on some models.

2.1.9 Check to make sure that the clean-out tool is attached to the handle on the machine. Do not operate the machine without the clean-out tool properly stored on the handle.

CLEARING A CLOGGED DISCHARGE CHUTE

Hand contact with the rotating auger/impeller inside the discharge chute is the most common cause of injury associated with snow throwers. DO NOT use your hand to clean out the discharge chute. To clear the chute:

1. STOP the engine. Remove the key.
2. Wait 10 seconds to be sure the auger/impeller blades have stopped rotating.
3. Always use the clean-out tool. DO NOT use your hands.

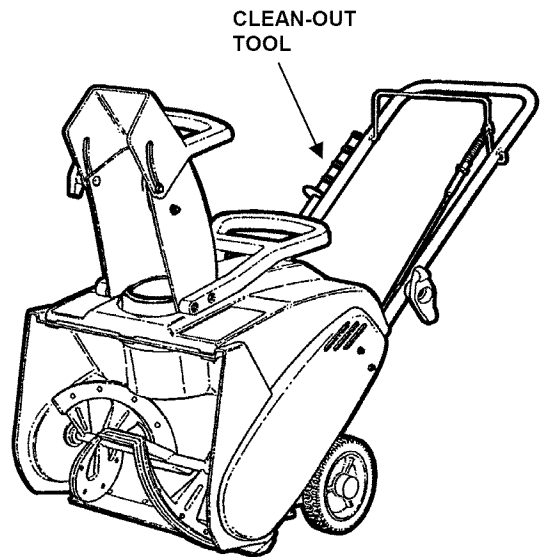

FIGURE 2.4

Section 2 - OPERATING INSTRUCTIONS

2.2 STARTING, STOPPING & OPERATION (RECOIL START MODELS)

2.2.1. ENGINE & AUGER

1. Move choke control to the choke "ON" position.
See Figure 2.5.

NOTE: Stop the auger by releasing the auger control.
Stop the engine by turning the key switch to the "OFF" position.

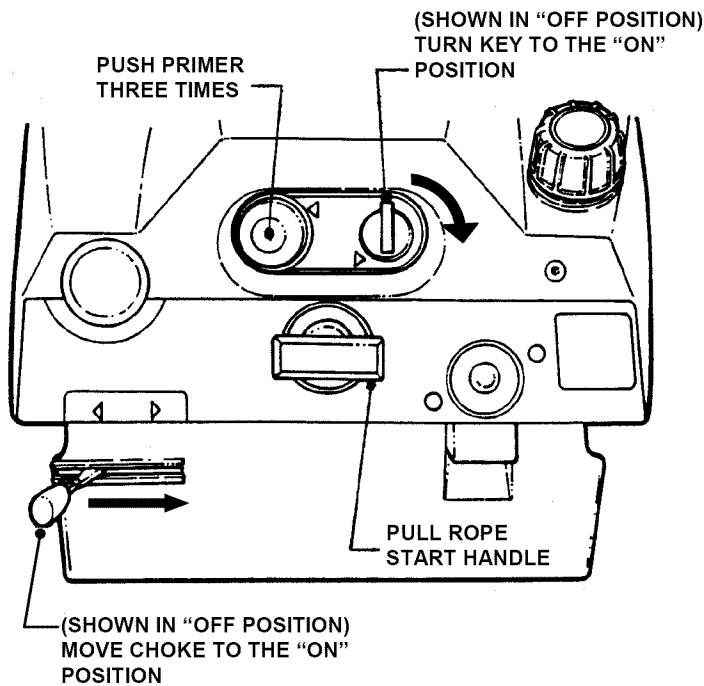

FIGURE 2.5

2. Turn ignition key to the "ON" position.
3. Push primer button three times to start a cold engine. **NOTE:** Do not use primer button to start warm engine.
4. Pull rope start handle to crank engine.
5. After engine starts, move the choke control to the no choke "OFF" position. Allow a brief warm-up until engine runs smooth.

WARNING
Objects can be thrown by the snow thrower while it is in operation. Thrown objects could cause serious injury to the operator or bystanders. Always wear safety goggles or other suitable eye protection. Keep people and pets away from area.

2.2.2. ENGAGING AUGER

1. Pull auger control against handle to engage auger. See Figure 2.6.

WARNING
Release auger clutch control and make sure auger/impeller has STOPPED before rotating discharge chute or adjusting deflector. DO NOT place hands near auger/impeller while engine is running.

2.2.3. DISCHARGE CHUTE and DEFLECTOR ADJUSTMENT

1. Release auger control and allow auger to come to a complete stop before performing any adjustments.
2. Loosen deflector knob and position deflector to desired angle. Retighten knob.
3. Rotate discharge chute in desired direction. See Figure 2.7.

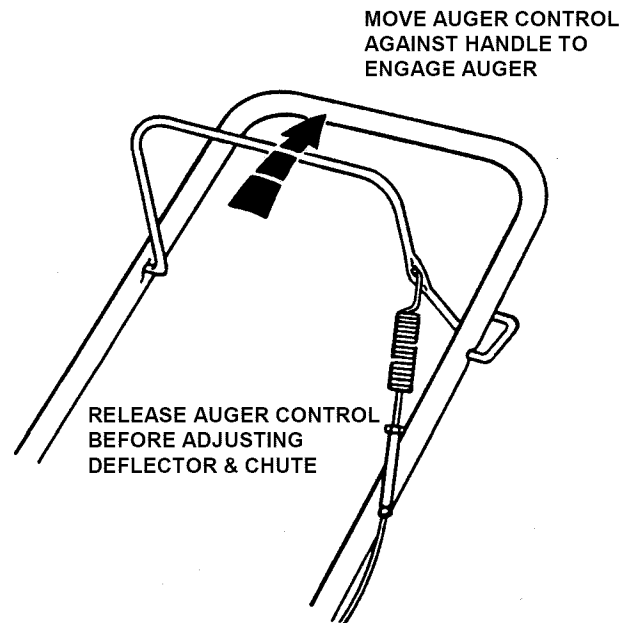

FIGURE 2.6

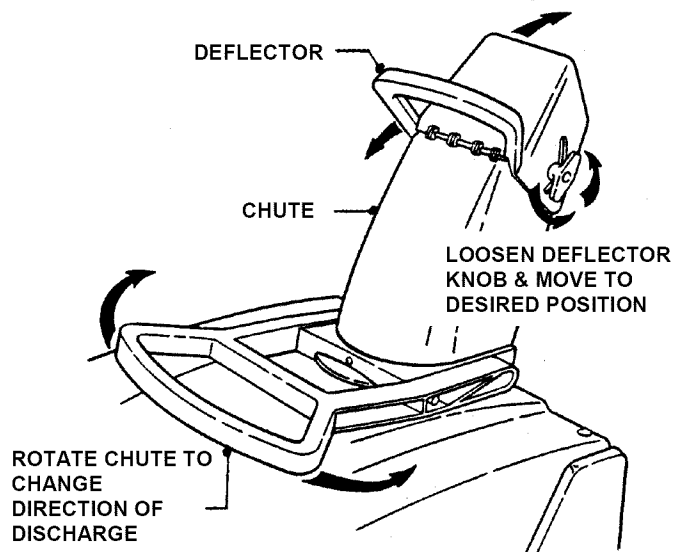

FIGURE 2.7

Section 2 - OPERATING INSTRUCTIONS

2.2.4. STOPPING

Stop the auger by releasing the auger control. Stop the engine by turning the key switch to the "OFF" position. Always remove key from key switch before leaving machine unattended. See Figure 2.8.

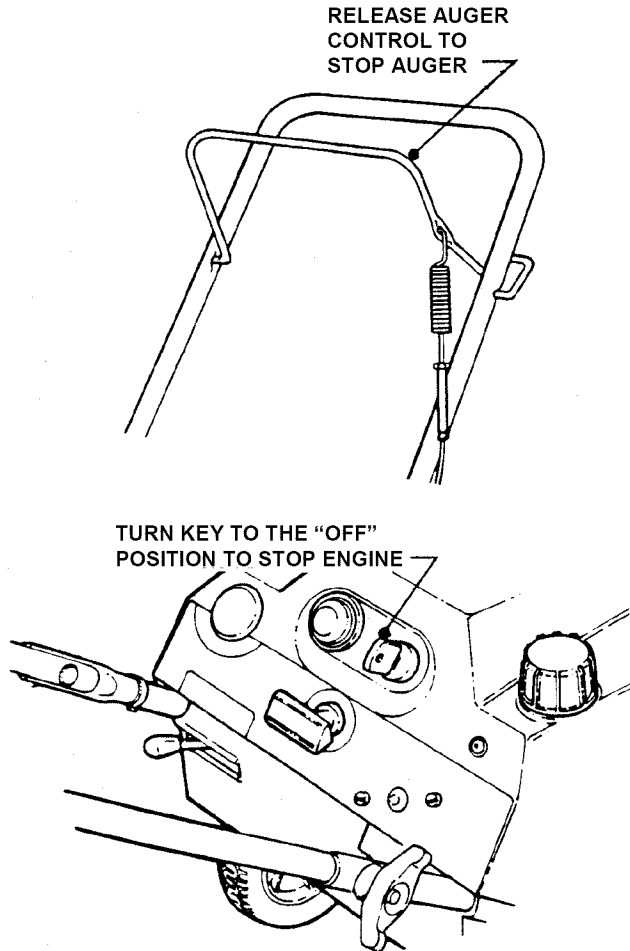

FIGURE 2.8

2.2 STARTING, STOPPING & OPERATION (ELECTRIC START MODELS)

2.2.5. ENGINE & AUGER

1. Connect the power cord to the starter switch box on machine's control panel then plug the other end into 120 volt AC receptacle.
2. Turn ignition key to the "ON" position.
3. Move choke control to the choke "ON" position. See Figure 2.9.
4. Push primer button three times to start a cold engine. **NOTE:** Do not use primer button to start warm engine.
5. Push the electric starter button. **DO NOT** hold button for more than 20 seconds to avoid damaging the starting motor. See Figure 2.9.
6. After engine starts, move the choke control to the no choke "OFF" position. Allow a brief warm-up until engine runs smooth.
7. Disconnect power cord from AC receptacle. Disconnect power cord from machine and remove cord from area where machine will be in operation.

NOTE: Stop the auger by releasing the auger control. Stop the engine by turning the key switch to the "OFF" position.

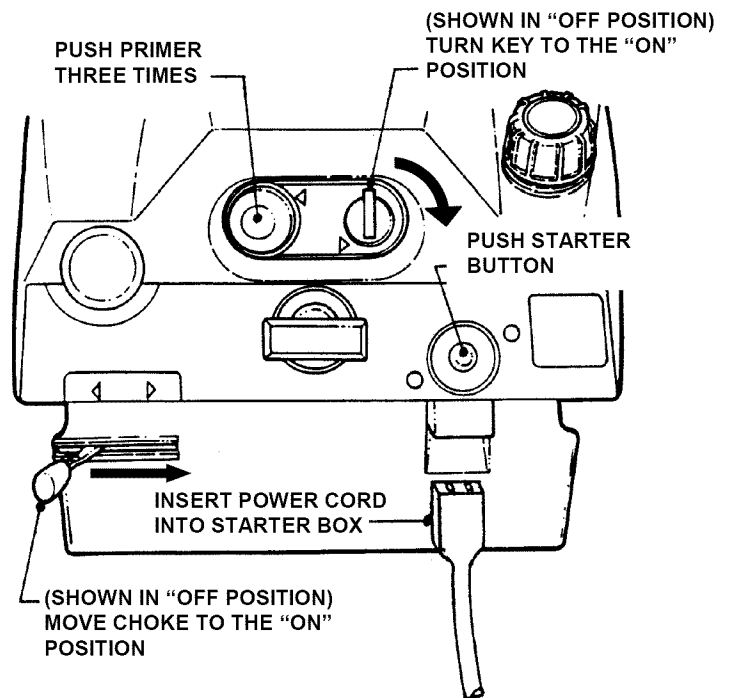

FIGURE 2.9

⚠ WARNING ⚠



DO NOT use an electrical extension cord that is damaged. A damaged electrical extension cord could cause a shock or fire. Thoroughly inspect electrical extension cord before using machine. If cord is damaged, do not use and do not operate machine. Replace damaged cord immediately. Contact your SNAPPER service dealer for assistance. To reduce the risk of electric shock, use only with an extension cord intended for outdoor use having a cord type: SW-A, SOW-A, STW-A, STOW-A, SJW-A, SJTW-A or SJTOW-A.

Section 2 - OPERATING INSTRUCTIONS

 **WARNING** 
Objects can be thrown by the snow thrower while it is in operation. Thrown objects could cause serious injury to the operator or bystanders. Always wear safety goggles or other suitable eye protection. Keep people and pets away from area.

2.2.6. ENGAGING AUGER

1. Pull auger control against handle to engage auger. See Figure 2.6.

 **DANGER** 
DO NOT clean out discharge chute with hands. Contact with moving parts inside chute will cause serious injury. Use clean out tool provided with machine.

 **WARNING** 
Release auger clutch control and make sure auger/impeller has STOPPED before rotating discharge chute or adjusting deflector. DO NOT place hands near auger/impeller while engine is running.

2.2.7. DISCHARGE CHUTE and DEFLECTOR ADJUSTMENT

1. Release auger control and allow auger to come to a complete stop before performing any adjustments.
2. Loosen deflector knob and position deflector to desired angle. Retighten knob.
3. Rotate discharge chute in desired direction. See Figure 2.7.

2.2.8. STOPPING

Stop the auger by releasing the auger control. Stop the engine by turning the key switch to the "OFF" position. Always remove key from key switch before leaving machine unattended. See Figure 2.8.

Section 3 - MAINTENANCE

3.1 INTRODUCTION

To retain the quality of the snow thrower, use genuine SNAPPER replacement parts only. Contact a local SNAPPER dealer for parts and service assistance. For the correct part or information for a particular snow thrower, always mention model and serial number.

3.2 SERVICE - AFTER FIRST 5 HOURS

3.2.1 CHECK AUGER DRIVE BELT

1. Visually check engine drive belt for cracking, fraying, severed or exposed belt strands. Replace worn belt before operating snow thrower. See Figure 3.1

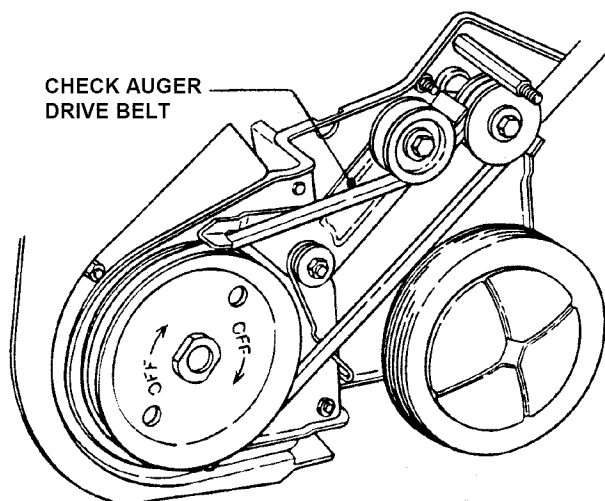

FIGURE 3.1

3.2.2 CHECK AUGER FLITE SHOE

1. Visually check flite shoes for cracking, fraying severed or exposed belt strands. Replace worn flite shoes before operating snow thrower. See Figure 3.2.

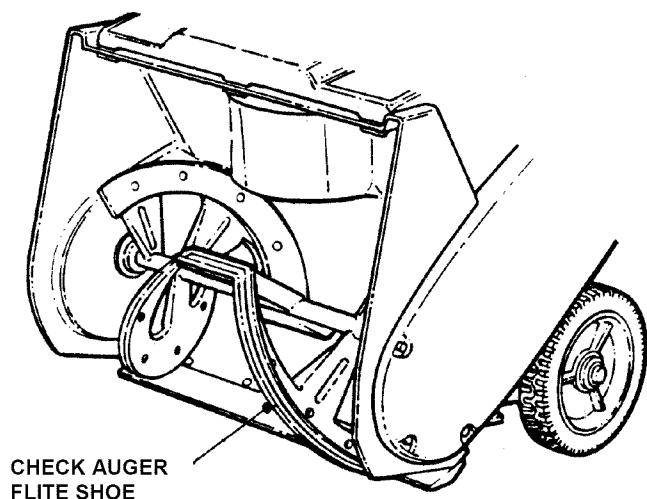

FIGURE 3.2

3.2.3 CHECK AUGER CLUTCH CONTROL CABLE

1. Visually check cable for fraying, kinking or severed cable strands. Replace cable and adjust tension before operating snow thrower. See Figure 3.3.

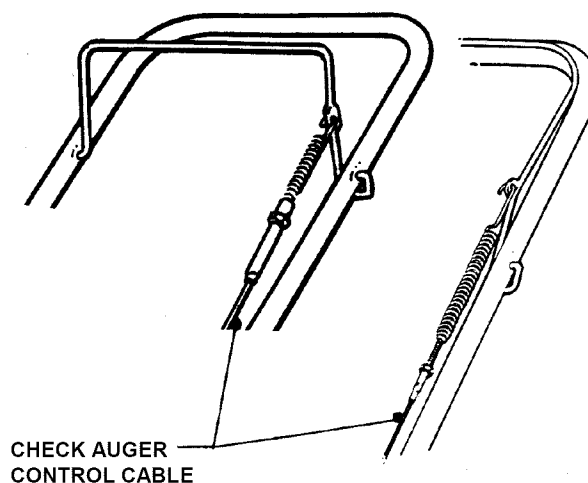

FIGURE 3.3

3.3 ANNUALLY (END OF EACH SEASON)

Perform all maintenance as described in the maintenance schedule.

3.3.1. Engine

Refer to engine owner's manual for service instructions.

3.3.2. Spark Plug

Refer to engine owner's manual for service instructions.

3.4 STORAGE PROCEDURE

Refer to the Engine Owner's Manual for directions regarding engine storage preparations. Prepare the snow thrower for "end of season" storage as follows:

1. Drain fuel from fuel tank and let engine run until all fuel is out of the carburetor.
2. **Disconnect and remove the spark plug wire away from spark plug before any other preparations are made!**
3. Tape all openings closed to prevent spraying water into exhaust or air intakes during washing.
4. Tilt snow thrower up on its wheels and thoroughly clean the underside of the auger.
5. Lubricate all exposed metal with a light coating of oil to prevent corrosion. **DO NOT** place any type of lubrication onto belt or pulleys.
6. Store the machine in a shed or other dry area, protected from weather.

Section 4 - REPAIR & ADJUSTMENTS



WARNING



DO NOT attempt any adjustments, maintenance, service, or repairs with engine running. Stop auger. Stop engine. Remove key. Remove spark plug wire and secure wire away from spark plug.

4.1 AUGER BELT ADJUSTMENT/REPLACEMENT

When operating machine release the auger clutch control. The auger should come to a complete stop in 5 seconds. If the auger does not come to a complete stop in the required time, check and adjust belt tension. Inspect belt frequently for signs of excessive wear. Observe drive belt for slippage due to wear when operating machine. If slippage does occur adjust as follows.

4.1.1. AUGER BELT CABLE ADJUSTMENT

1. Measure control cable extension from a relaxed position to full extended position. Move control lever against handle. Measure the overall length of the spring. The length of the cable spring should increase by 1/2" to 3/4" when the clutch control is depressed. See Figure 4.1.

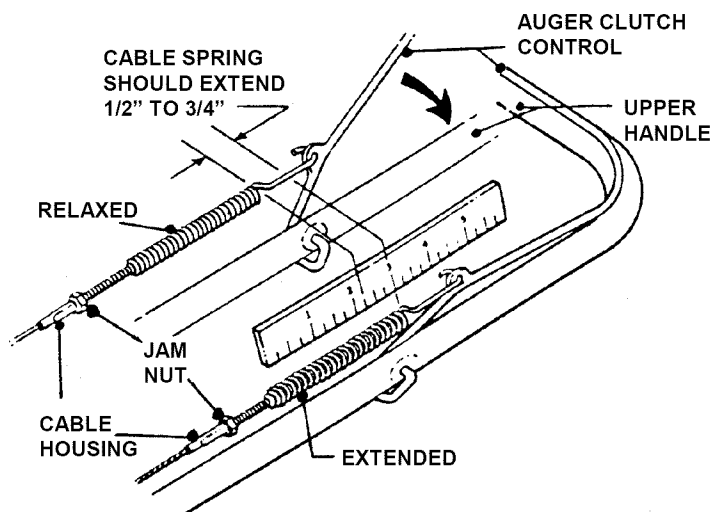

FIGURE 4.1

2. Loosen jam nut at the upper end of cable. Hold threaded end of cable and then turn cable clockwise until correct extension is achieved. Retighten jam nut.

IMPORTANT: DO NOT over tighten cable. The control cable must have slack for the auger brake to function properly. If the auger control cannot be properly adjusted, belt adjustment and/or replacement will be required. Refer to Section "Auger Belt Idler Pulley Adjustment".

4.1.2. AUGER BELT IDLER PULLEY ADJUSTMENT

NOTE: To adjust the idler pulley and properly tension the auger belt, the auger control cable adjustment must first be loosened as described in the following step. Cable adjustment must be checked after completing the idler pulley adjustment.

1. Loosen jam nut at the upper end of cable. Hold threaded end of cable and then turn metal housing of cable counter clockwise until threaded portion of cable is extracted from metal housing. Reinstall 1/2" of the threaded portion of cable back into metal housing. Retighten jam nut.
2. Remove belt cover. See Figure 4.2

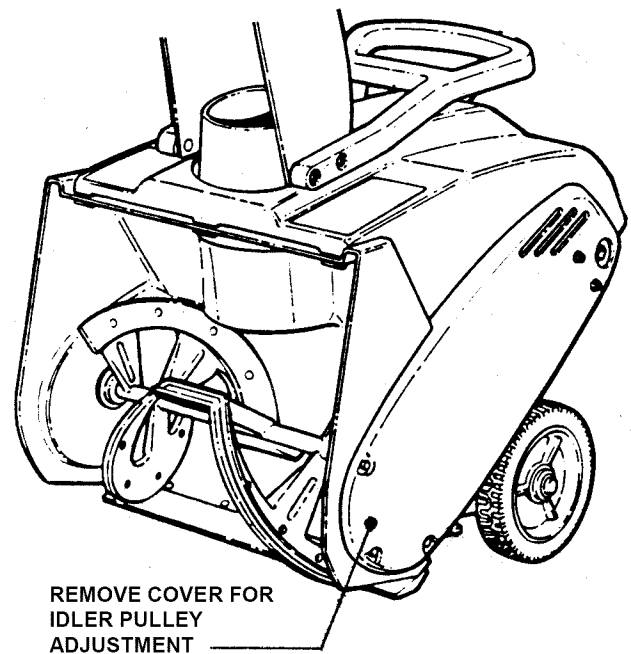

FIGURE 4.2

(Continued on the Next Page)

Section 4 - REPAIR & ADJUSTMENTS

WARNING
DO NOT attempt any adjustments, maintenance, service, or repairs with engine running. Stop auger. Stop engine. Remove key. Remove spark plug wire and secure wire away from spark plug.

4.1.2. AUGER BELT IDLER PULLEY ADJUSTMENT (Continued From Previous Page)

- Loosen nut and bolt that secures the idler pulley to idler arm. Move idler pulley down for more tension or up for less tension on belt. See Figure 4.3. Retighten bolt and nut securely.
- Recheck cable for proper extension. Refer to Section "Auger Belt Cable Adjustment".
- Reinstall belt cover.

IDLER PULLEY ASSEMBLY SHOWN EXPLODED TO SHOW DETAIL OF IDLER ARM SLOT

MOVE IDLER PULLEY UP TO DECREASE OR DOWN TO INCREASE TENSION ON BELT

BELT COVER RETAINING STUDS

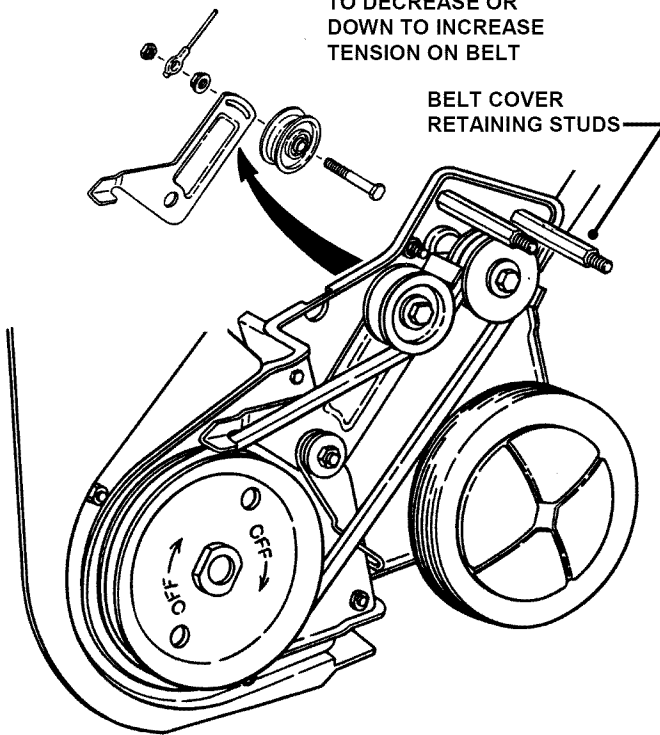

FIGURE 4.3

4.1.3. AUGER BELT REPLACEMENT

Inspect belt frequently for signs of excessive wear. Visually check engine drive belt for cracking, fraying, severed or belt strands exposed.

- Remove belt cover. See Figure 4.2.
- Remove both belt cover retaining studs.
- Remove belt guide. See Figure 4.4.
- Push the spring tensioned idler pulley down and remove belt.

- Push the spring tensioned idler pulley down and install new belt. See Figure 4.5.

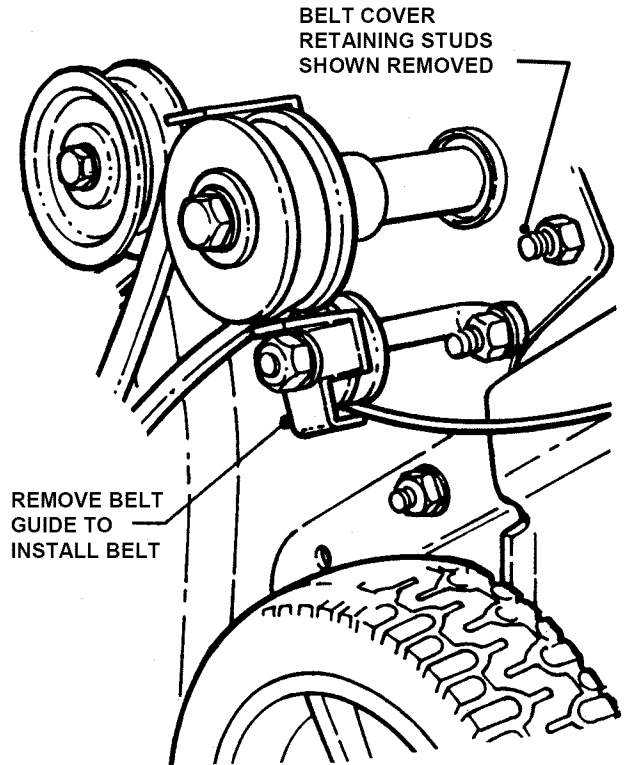

FIGURE 4.4

PUSH IDLER DOWN TO REMOVE & INSTALL AUGER BELT

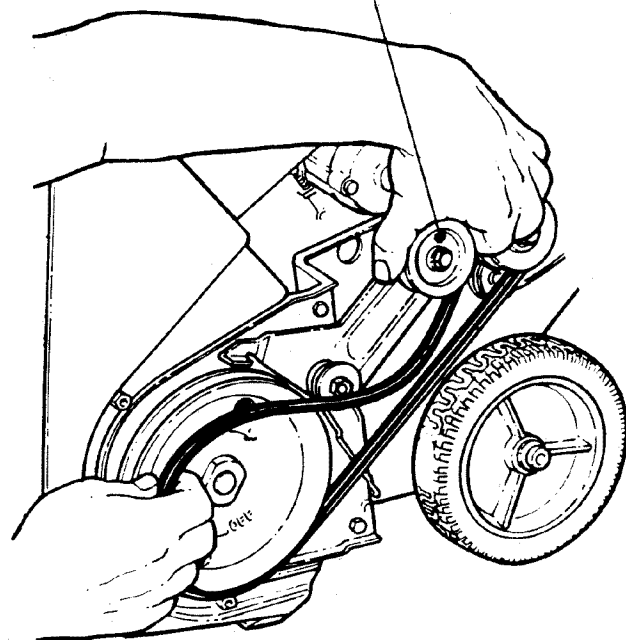

FIGURE 4.5

Section 4 - REPAIR & ADJUSTMENTS



WARNING



DO NOT attempt any adjustments, maintenance, service, or repairs with engine running. Stop auger. Stop engine. Remove key. Remove spark plug wire and secure wire away from spark plug.

4.1.3. AUGER BELT REPLACEMENT (Continued From Previous Page)

5. Reinstall belt guide.

IMPORTANT: Make sure when reinstalling belt guide that it does not touch drive pulley. Belt guide should have an equal amount of clearance on both belt guide fingers. See Figure 4.6.

6. Refer to Section "Auger Belt Adjustment/Replacement".

7. Reinstall belt cover and tighten screws securely. DO NOT overtighten.

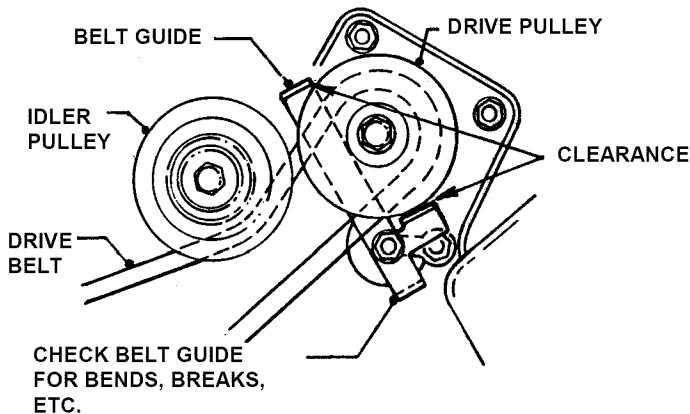

FIGURE 4.6

4.1.4. AUGER FLITE SHOE REPLACEMENT

Inspect flite shoes frequently for signs of excessive wear. Visually check flite shoes for cracking, fraying, severed or belt strands exposed. #6-1215 Flite Shoe Kit for 17" Auger Models and #6-1213 Flite Shoe Kit for 19" Auger Models. These kits will be required to replace existing flite shoes.

1. Tilt machine backward to gain access to auger. Secure machine in the tilted position to prevent tipping over.

2. Remove all self-tapping screws that secure the flite shoes to auger. Save screws for future use.

3. Install new flite shoes to auger using self-tapping screws removed previously. Tighten screws securely. DO NOT overtighten. See Figure 4.7.

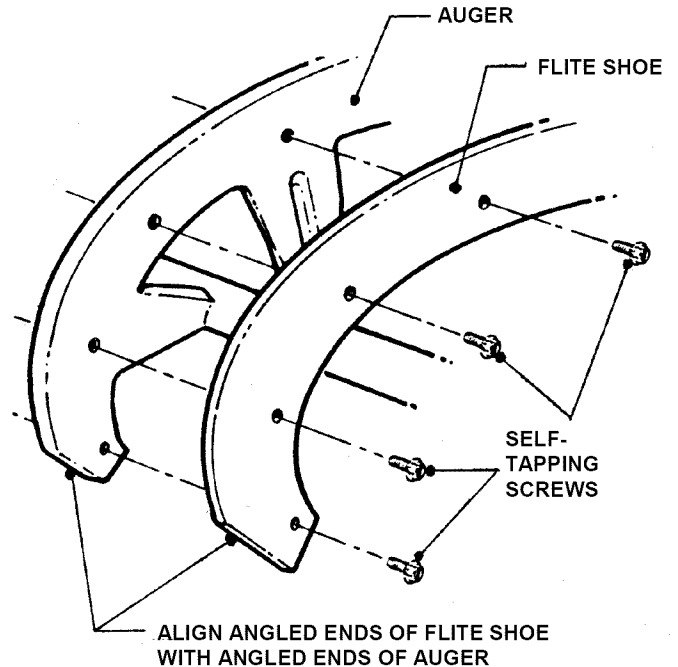

FIGURE 4.7

TROUBLESHOOTING

PROBLEM	PROBABLE CAUSE	CORRECTIVE ACTION
Engine Will Not Start Using Recoil Starter	1. Fuel tank empty.	1. Fill fuel tank with fresh fuel/oil mix.
	2. Engine needs choking & priming.	2. Move choke control to "CHOKE" position. Push primer bulb three times.
	3. Spark plug fouled or wire disconnected.	3. Replace spark plug. Attach plug wire onto spark plug.
Engine Will Not Crank Using Electric Starter	1. Power extension cord not plugged into machine or 110 Volt outlet.	1. Plug power extension cord into machine & into 110 Volt outlet.
	2. Power extension cord damaged.	2. Discard damaged power extension cord
	3. Starter switch damaged or faulty.	3. Replace starter switch.
	4. Key switch turned to "OFF" position.	4. Turn key switch to "ON" position.
Engine Stalls or Stops After Running	1. Fuel and 2-Cycle oil mixture ratio incorrect.	1. Mix fuel and 2-Cycle oil to 50:1 ratio.
	2. Choke control in the "CHOKE" position.	2. Move choke control to "OFF" position.
	3. Fuel tank empty.	3. Fill with fuel to proper level.
	4. Air intake clogged with snow or debris.	4. Unclog air intake.
	5. Spark plug defective or gap set improperly.	5. Service spark plug.
	6. Water, debris or stale fuel in fuel system.	6. Drain and clean fuel system.
	7. Fuel filter clogged.	7. Replace with new in line filter.
Engine Loses Power	1. Fuel and 2-Cycle oil mixture ratio incorrect.	1. Mix fuel and 2-Cycle oil to 50:1 ratio.
	2. Spark plug faulty.	2. Service spark plug.
	3. Water, debris or stale fuel in fuel system.	3. Drain and clean fuel system.
Excessive Vibration	1. Damaged, out of balance or bent auger.	1. Service auger.
	2. Loose engine or auger components.	2. Service and tighten loose components.
	3. Loose or missing flightings.	3. Replace flightings.
	4. Cracked, severed or frayed belt	4. Replace belt.
	5. Bent or loose Idler pulley	5. Tighten or replace pulley.
Poor Snow Discharging	1. Clogged discharge chute.	1. Stop engine and unclog discharge chute.
	2. Damaged or bent auger or components.	2. Service auger or components.
	3. Cracked, severed or frayed belt.	3. Replace belt.
	4. Belt tension out of adjustment.	4. Adjust belt tension.
	5. Auger flightings damaged or missing.	5. Replace flightings.

SERVICE SCHEDULE

ITEM	SERVICE PERFORMED	REF.	EACH USE	5 HRS	25 HRS	50 HRS	100 HRS	EACH SEASON
Spark Plug	Replace	Engine Manual.					X	
Engine Cooling System	Clean Shroud & Fins	Engine Manual					X	
Drive Belts	Check For Wear And Tension	Page 11-14			X	X		X
Auger & Flight Shoe	Check For Wear, Damage & Replacement	Page 11, 14	X					

4.2. MAINTENANCE/REPLACEMENT PARTS

MAINTENANCE PARTS	
Auger Drive Belt	7024618
Auger Clutch Control Cable	7024662
Auger Flite Shoe Kit for 17" Auger Models	7061215
Auger Flite Shoe Kit for 19" Auger Models	7061213
Parts Manual for L.E. Models Series 1 Snow Thrower Models: LE3171R, LE3191R, LE3191E	7006030

SNAPPER®

2 YEAR LIMITED WARRANTY

For two (2) years from purchase date for the original purchaser's residential, non-commercial use, **SNAPPER**, through any authorized **SNAPPER** dealer will replace, free of charge (except for taxes where applicable), any part or parts found upon examination by the factory at McDonough, Georgia, to be defective in material or workmanship or both.

For ninety (90) days from purchase date for the original purchaser's commercial, rental, or other non-residential use, **SNAPPER**, through any authorized **SNAPPER** dealer will replace, free of charge, any part or parts found upon examination by the factory at McDonough, Georgia, to be defective in material or workmanship or both.

All transportation costs incurred by the purchaser in submitting material to an authorized **SNAPPER** dealer for replacement under this warranty must be paid by the purchaser.

This warranty does not apply to certain transmissions, to engines and their components, and batteries, as these items are warranted separately. This warranty does not apply to parts that have been damaged by accident, alteration, abuse, improper lubrication, normal wear, or other cause beyond the control of **SNAPPER**. This warranty does not cover any machine or component part that has been altered or modified changing safety, performance, or durability.

Batteries have a one (1) year warranty period with free replacement if required for one (1) year from the original purchase date. **SNAPPER** will not be responsible for any installation cost incurred. The battery warranty only covers original equipment batteries and does not cover damage to the battery or machine caused by neglect or abuse, destruction by fire, explosion, freezing, overcharging, improper maintenance, or use of improper electrolyte.

There is no other express warranty.

DISCLAIMER OF WARRANTY

Implied warranties, including those of merchantability and fitness for a particular purpose, are limited to two (2) years from purchase date for the original purchaser's residential or other non-commercial use, and ninety (90) days from purchase for the original purchaser's commercial, rental or other non-residential use, and to the extent permitted by law, any and all implied warranties are excluded. This is the exclusive remedy. Liabilities for consequential damages, under any and all warranties are excluded.

Some states do not allow limitations on how long an implied warranty lasts, or do not allow the exclusion or limitation of incidental or consequential damages, so the above limitation or exclusion may not apply to you.

This warranty gives you specific legal rights, and you may also have other rights which vary from state to state.

WARNING: THE USE OF REPLACEMENT PARTS OTHER THAN GENUINE SNAPPER PARTS MAY IMPAIR THE SAFETY OF SNAPPER PRODUCTS AND WILL VOID ANY LIABILITY AND WARRANTY BY SNAPPER ASSOCIATED WITH THE USE OF SUCH PARTS.

IMPORTANT: Please fill out the attached **SNAPPER** Product Registration Card immediately and mail to:
Snapper's Product Registration Center, P.O. Box 1379, McDonough, Georgia 30253

SNAPPER PRODUCT REGISTRATION FORM

**IMPORTANT: KEEP THIS INFORMATION FOR YOUR PERSONAL RECORDS
(Complete the following information on your Snapper purchase)**

Model Number _____

Serial Number _____

Date of Purchase _____

Retailer _____

Retailer's Phone Number _____

It is very important that you register your purchase with Snapper to ensure warranty coverage. Please mail your product registration card to:

Snapper at P.O. Box 1379, McDonough, Georgia 30253.

Or you may register on line at www.snapper.com.

You can contact us at our web site or if you would like to speak with a Customer Service Representative. Call us at the Snapper Customer Relations Center. For faster service please have your Serial Number and Model Number available.

Call the Snapper Customer Relations Center at 1-800-935-2967.

Safety Instructions & Operator's Manual for

SNAPPER®

L.E. SINGLE STAGE SMALL FRAME SNOW THROWER SERIES 1

IMPORTANT

Snapper products are built using engines that meet or exceed all applicable emissions requirements on the date manufactured. The labels on those engines contain very important emissions information and critical safety warnings. Read, Understand, and Follow all warnings and instructions in this manual, the engine manual, and on the machine, engine and attachments. If you have any questions about your Snapper product, contact your local authorized Snapper dealer or contact Snapper Customer Service at Snapper, McDonough, GA. 30253. Phone: (1-800-935-2967).



WARNING

BATTERY POSTS, TERMINALS AND RELATED ACCESSORIES CONTAIN LEAD AND LEAD COMPOUNDS, CHEMICALS KNOWN TO THE STATE OF CALIFORNIA TO CAUSE CANCER AND BIRTH DEFECTS OR OTHER REPRODUCTIVE HARM. WASH HANDS AFTER HANDLING.



WARNING

ENGINE EXHAUST, SOME OF ITS CONSTITUENTS, AND CERTAIN VEHICLE COMPONENTS CONTAIN OR EMIT CHEMICALS KNOWN TO THE STATE OF CALIFORNIA TO CAUSE CANCER OR OTHER REPRODUCTIVE HARM.

SNAPPER® McDonough, GA., 30253 U.S.A.

www.snapper.com

COPYRIGHT © 2006
SNAPPER – A DIVISION OF SIMPLICITY MFG., INC.
ALL RIGHTS RESERVED

INSTRUCTION No. 7100947 (I.R. 6/26/2006)
TP 100-5205-00-SX-SN

Safety Instructions & Operator's Manual for **SNAPPER**[®]

L.E. SINGLE STAGE SMALL FRAME SNOW THROWER SERIES 1

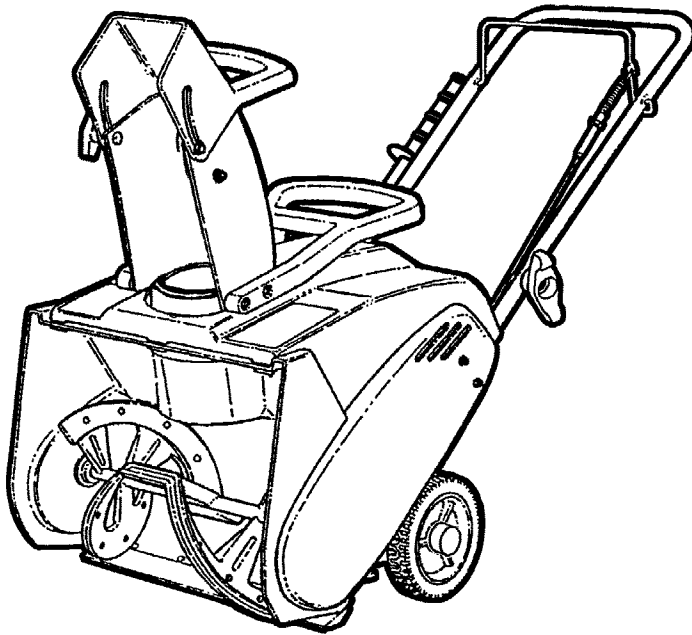

MODELS
LE3171R
LE3191R
LE3191E

MODEL NUMBER EXPLANATION

L E 3 19 1 E

MODEL DESIGNATION
ENGINE POWER *

ENGINE OPTIONS
SERIES DESIGNATION
AUGER WIDTH

L – Light Weight Frame	17 – 17" Auger Width	1 -- Series Designation
E – Easy Operation	19 – 19" Auger Width	E – 110 Volt Electric Start
3 – 3.0 (Engine Power *)		R – Recoil Start

Thank you for buying a SNAPPER Product! Before operating your Snow Thrower, read this manual carefully and pay particular attention to the "IMPORTANT SAFETY INSTRUCTIONS" on Pages 2 - 4. Remember that all power equipment can be dangerous if used improperly. Also keep in mind that SAFETY requires careful use in accordance with the operating instructions and common sense.

* Actual sustained engine power will likely be lower due to operating limitations and environmental factors. See POWER RATINGS on Page 5 for further information.

SNAPPER®McDonough, GA., 30253 U.S.A.

COPYRIGHT © 2006
SNAPPER – A DIVISION OF SIMPLICITY MFG., INC.
ALL RIGHTS RESERVED

INSTRUCTION No. 7100947 (I.R. 6/26/2006)
TP 100-5205-00-SX-SN



IMPORTANT SAFETY INSTRUCTIONS



WARNING: This powerful machine is capable of amputating hands and feet and can throw objects that can cause injury and damage! Failure to comply with the following instructions may result in serious injury to the operator or other persons. The owner of the snow thrower must understand these instructions and, furthermore, must allow only persons who understand these instructions to operate snow thrower. Each person operating the snow thrower must be of sound mind and body and must not be under the influence of any substance, which might impair vision, dexterity, or judgment. If you have any questions pertaining to your snow thrower which your dealer cannot answer to your satisfaction, call or write the Customer Service Department at SNAPPER, McDonough, Georgia 30253. Phone: 800/935-2967.

PROTECTION FOR CHILDREN

Tragic accidents can occur if the operator is not alert to the presence of children. Children are often attracted to the machine and the snow removal activity. Never assume that the children will remain where you last saw them.

1. **DO NOT** allow children in the area when snow thrower is being operated.
2. **DO NOT** allow pre-teenage children to operate snow thrower.
3. **ALLOW** only responsible adults and teenagers with mature judgment to operate the machine and then only after being thoroughly instructed and under the close supervision of an experienced adult operator.
4. Keep the area clear of all persons, particularly small children and pets.
5. Know how to **STOP** the snow thrower and disengage the controls quickly.

PREPARATION

1. Warn everyone in advance to stay clear of area. Keep especially watchful for children and pets darting into area while operating.
2. Read, understand, and follow instructions and warnings in this manual and on the machine. Know the controls and the proper use of the snow thrower before starting.
3. Data indicates that operators, age 60 and above, are involved in a large percentage of snow thrower-related injuries. These operators should evaluate their ability to operate the snow thrower safely enough to protect themselves and others from serious injury.
4. Disengage all clutches and shift into neutral before starting the engine (motor).
5. Wear adequate winter clothing including boots which will give you maximum footing on slippery surfaces. Exercise **CAUTION** to avoid slipping or falling.
6. **DO NOT** wear loose fitting clothing that can get caught in moving parts.
7. Before the first snow fall, check the area to be cleared and remove all objects such as doormats, sticks, toys, wires, rocks, etc., which could be hurled or jam the snow thrower.

PREPARATION

8. Survey the area to be cleared beforehand and plan where snow is to be blown. Be prepared to release auger/impeller clutch or to change discharge chute direction quickly to discharge away from windows, cars, buildings and doorways to avoid property damage or personal injury from hurled objects.
9. Use only approved extension cords and receptacles in good condition and with sufficient capacity to carry the current to the machine if equipped with electric starting motors.
10. Handle fuel with extra care. Fuels are flammable and vapors are explosive. Store only in an approved fuel container. Never remove fuel cap or add fuel with the engine running. Add fuel outdoors only with the engine stopped and cool. Clean spilled fuel and oil from machine. **DO NOT** smoke. **DO NOT** run engine indoors.

OPERATIONAL PRECAUTIONS

1. Before starting, make visual check to make sure auger/impeller housing is clear and all guards and shields are in place and tight.
2. **DO NOT** operate machine without proper guards shields, deflectors, or other safety protective devices in place and functioning properly.
3. Should the auger/impeller become clogged, release the auger/impeller clutch control and, as an additional precaution, **STOP** the engine before attempting to unclog the auger/impeller or discharge chute.
4. **DO NOT** attempt to unclog the auger/impeller or discharge chute by reaching in with your hands. Use the clean-out tool or similar implement to unclog.
5. **DO NOT** attempt to unclog the auger/impeller or discharge chute with the engine running. **STOP** engine and remove key. Wait for all motion to **STOP**.
6. **STOP** engine (motor) and remove key before leaving the operator position for any reason. **DO NOT** put hands or feet near or under rotating parts. Keep clear of the discharge opening at all times.



IMPORTANT SAFETY INSTRUCTIONS



OPERATIONAL PRECAUTIONS

7. Start engine only where exhaust fumes will be safely dissipated. Allow a brief warm-up period, and practice operation of controls outside before putting the machine to work.
8. After striking a foreign object, STOP the engine (motor), remove the key, and remove the wire from spark plug. Thoroughly inspect the snow thrower for any damage, and repair the damage before restarting and operating the snow thrower.
9. STOP the engine if the machine starts to vibrate excessively as this normally indicates mechanical problems. Remove the key and disconnect the spark plug wire to prevent unintentional starting before servicing or repairing the machine.
10. Exercise extreme CAUTION when operating on slopes.
11. DO NOT clear snow across the face of slopes. Exercise extreme CAUTION when changing direction on slopes. DO NOT attempt to clear steep slopes.
12. DO NOT leave machine unattended with the engine running. STOP engine and remove key to prevent unauthorized operation.
13. Release clutch control and make sure auger/impeller has STOPPED before rotating discharge chute, adjusting deflector, or placing hands near auger/impeller.
14. DO NOT use snow thrower on surfaces above ground level, such as, a roof of a building.
15. DO NOT direct the discharge toward people or areas where property damage can occur. Keep children and others away.
16. Exercise extreme CAUTION when operating on or crossing gravel drives, walks, or roads. Stay alert for hidden hazards or traffic.
17. DO NOT overload the machine capacity by attempting to clear snow at too fast a rate.
18. Never operate the machine at high transport speeds on slippery surfaces. Look behind and use care when backing.
19. Disengage power to the auger/impeller when snow thrower is transported or not in use.
20. Use only attachments and accessories approved by the manufacturer of the snow thrower (such as wheels weights, counterweights, cabs and the like).
21. Never operate the snow thrower without good visibility or light. Always be sure of your footing, and keep a firm hold on the handles. Walk; never run.
22. DO NOT touch a hot engine or muffler.

CLEARING A CLOGGED DISCHARGE CHUTE

Hand contact with the rotating auger/impeller inside the discharge chute is the most common cause of injury associated with snow throwers. DO NOT use your hand to clean out the discharge chute. To clear the chute:

1. STOP the engine. Remove the key.
2. Wait 10 seconds to be sure the auger/impeller blades have stopped rotating.
3. Always use the clean-out tool. DO NOT use your hands.

SAFE HANDLING OF GASOLINE

To avoid personal injury or property damage, use extreme care in handling gasoline. Gasoline is extremely flammable and the vapors are explosive

1. Extinguish all cigarettes, cigars, pipes and other sources of ignition.
2. Use only an approved fuel container.
3. DO NOT remove fuel cap or add fuel with the engine running. Allow the engine to cool before refueling.
4. DO NOT refuel the machine indoors.
5. DO NOT store the machine or fuel container inside where there is an open flame, spark or pilot light such as on a water heater or other appliances.
6. DO NOT fill fuel containers inside a vehicle or on a truck or trailer bed with a plastic liner. Always place the containers on the ground away from the vehicle before filling.
7. Remove gas-powered equipment from the vehicle or trailer and refuel it on the ground. If this is not possible, then refuel equipment using a portable container, rather than a gasoline dispenser nozzle.
8. DO NOT start gas powered equipment in enclosed vehicles or trailers.
9. Keep the nozzle in contact with the rim of the fuel tank or container opening at all times until fueling is complete. DO NOT use a nozzle lock-open device
10. If fuel is spilled on clothing, change clothing immediately.
11. DO NOT overfill a fuel tank. Replace fuel cap and tighten securely.



IMPORTANT SAFETY INSTRUCTIONS



MAINTENANCE AND STORAGE

1. **DO NOT** store machine or fuel container inside where fumes may reach an open flame, spark, or pilot light as in a water heater, furnace, clothes dryer or other gas appliance. Allow engine to cool before storing machine in an enclosure. Store fuel container out of reach of children in a well ventilated, unoccupied building.
2. Keep machine and engine free of excess oil, grease and spilled fuel to reduce fire hazard.
3. When draining fuel tank, drain fuel into an approved container outdoors and away from open flame.
4. Inspect all bolts, nuts and screws frequently and keep properly tightened.
5. Use only recommended shear bolts (if equipped) to prevent possible damage to machine.
6. Service engine and make adjustments only when engine is stopped. Remove key, remove wire from spark plug, secure wire away from plug, and disconnect cord from electric starting motors to prevent accidental starting.
7. **DO NOT** change engine governor speed settings or overspeed engine.
8. **DO NOT** test for spark by grounding the spark plug next to spark plug hole. Spark from the plug could ignite gas exiting engine.
9. Have machine serviced by an authorized SNAPPER dealer at least once a year and have the dealer install any new safety devices.
10. Maintain safety and instruction labels as necessary.
11. Use only genuine SNAPPER replacement parts to assure that original standards are maintained.

NOTE: Specifications are correct at time of printing and are subject to change without notice.

TABLE OF CONTENTS

SECTION 1 - IMPORTANT SAFETY INSTRUCTIONS	2-4
TABLE OF CONTENTS.....	5
SECTION 2 - OPERATING INSTRUCTIONS	6-10
Pre-start Checklist	6-7
Starting & Stopping Engine (Recoil Start Models).....	8-9
Starting & Stopping Engine (Electric Start Models)	9-10
Starting & Stopping Auger	9-10
SECTION 3 - MAINTENANCE INSTRUCTIONS	11
Checking Auger Drive Belt	11
Checking Auger Flite Shoes.....	11
Checking Clutch Control Cable	11
Annually – End of Each Season.....	11
Engine	11
Spark Plug	11
Storage Procedure	11
SECTION 4 - REPAIR AND ADJUSTMENTS	12-14
Auger Drive Belt Adjustment	12-13
Auger Drive Belt Replacement.....	13-14
Auger Flite Shoe Replacement	14
TROUBLESHOOTING	15
SERVICE SCHEDULE	15
Maintenance/Replacement Parts	15
WARRANTY AND PRODUCT REGISTRATION	16-17

Technical Information

Power Ratings

The power rating labels for individual gas engine models are initially developed by starting with SAE (Society of Automotive Engineers) code J1940 (Small Engine Power & Torque Rating Procedure) (Revision 2002-05). The above values may not necessarily represent the maximum gross power output of a gas engine per SAE J1995 Engine Power Test Code -- Gross Power Rating. The maximum gross power output of these gas engines may be significantly higher in accordance with the SAE J1995 standard. Given both the wide array of products on which our engines are placed, and the variety of environmental issues applicable to operating the equipment, it may be that the gas engine you have purchased will not develop the rated power when used in a piece of power equipment (actual "on-site" power). This difference is due to a variety of factors including, but not limited to, the following: differences in altitude, temperature, barometric pressure, humidity, fuel, engine lubrication, maximum governed engine speed, individual engine to engine variability, design of the particular piece of power equipment, the manner in which the gas engine is operated, gas engine run-in to reduce friction and clean out the combustion chambers, adjustments to the valves and carburetor, and other factors. The power ratings may also be adjusted based on comparisons to other similar engines utilized in similar applications, and will therefore not necessarily match the values derived using the foregoing codes.

Section 2 - OPERATING INSTRUCTIONS

2.1 PRE-START CHECK LIST

Make the following checks and perform the service required before each start-up.

2.1.1. Check guards, chutes, deflectors and covers to make sure all are in place and securely tightened.

2.1.2. Check auger control to insure it works freely. See Figure 2.1.

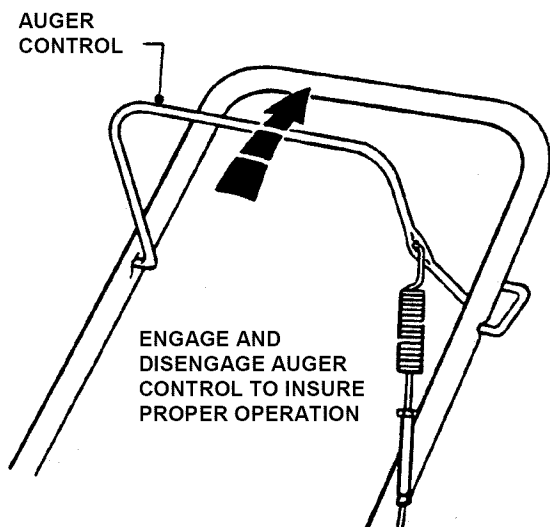

FIGURE 2.1

2.1.3. Check chute operation. Rotate chute to insure smooth rotation throughout its range.

STANDARD FLUID MEASUREMENT (50:1 Ratio)

GASOLINE (Gallons)	2 CYCLE OIL (Ounces)
0.25	.64
0.50	1.3
0.75	1.9
1.00	2.6
1.25	3.2
1.50	3.8
2.00	5.1

METRIC FLUID MEASUREMENT (50:1 Ratio)

GASOLINE (Liters)	2 CYCLE OIL (Cubic Centimeters)
0.50	10
1.00	20
1.50	30
2.00	40
2.50	50
3.00	60
4.00	80

FIGURE 2.2

(Continued on Next Page)

WARNING

Use approved fuel container. **DO NOT** smoke near open fuel container. **DO NOT** fill fuel tank indoors or when engine is running. Allow engine to cool for at least ten minutes before refilling. Wipe off any spilled fuel before starting engine. **DO NOT** run engine indoors.

2.1.4. Mix fresh, good quality unleaded gasoline and SNAPPER 2-cycle engine oil or equivalent. Mix fuel and oil to a 50:1 ratio. See Figure 2.2.

2.1.5. Add premix fuel to tank after pushing the machine outside where fumes can safely dissipate. Make sure cap is tightened after refueling. Refer to Engine Owners Manual for specifications.

2.1.6. Check auger housing, must be free of all obstructions. Clean engine of any accumulation of spilled fuel, dirt, etc.

2.1.7 Make sure the clean-out tool is mounted in the storage position on the snow thrower.

Section 2 - OPERATING INSTRUCTIONS

2.1 PRE-START CHECK LIST

(Continued from Previous Page)

Make the following checks and perform the service required before each start-up.

⚠ DANGER ⚠

DO NOT clean out discharge chute with hands. Contact with moving parts inside chute will cause serious injury. Use clean out tool provided with machine.

- 2.1.9 Check to make sure that the clean-out tool is attached to the handle on the machine. Do not operate the machine without the clean-out tool properly stored on the handle.

CLEARING A CLOGGED DISCHARGE CHUTE

Hand contact with the rotating auger/impeller inside the discharge chute is the most common cause of injury associated with snow throwers. **DO NOT** use your hand to clean out the discharge chute. To clear the chute:

1. **STOP** the engine. Remove the key.
2. Wait 10 seconds to be sure the auger/impeller blades have stopped rotating.
3. Always use the clean-out tool. **DO NOT** use your hands.

⚠ WARNING ⚠

DO NOT use an electrical extension cord that is damaged. A damaged electrical extension cord could cause a shock or fire. Thoroughly inspect electrical extension cord before using machine. If cord is damaged, do not use and do not operate machine. Replace damaged cord immediately. Contact your SNAPPER service dealer for assistance. To reduce the risk of electric shock, use only with an extension cord intended for outdoor use having a cord type: SW-A, SOW-A, STW-A, STOW-A, SJW-A, SJTW-A or SJTOW-A.

2.1.7. Check and make sure extension cord is in good condition. Extension cord should not have any broken insulation or exposed wires. Use an extension cord that is heavy enough to carry the correct amount of current to the machine. See Figure 2.3 for correct size to use depending on cord length and nameplate ampere rating. If in doubt, use the next heavier gauge cord.

MINIMUM GAUGE FOR CORD SETS					
120 Volt		Total Length of Cord in Feet			
Rating - Amps		25 ft.	50 ft.	100 ft.	150 ft.
More Than	Not More Than	A.W.G.			
0	6	18	16	16	14
6	10	18	16	14	12
10	12	16	16	14	12
12	16	14	12	Not Recommended	

FIGURE 2.3

2.1.8. Check the AC electrical outlet that will be used and make sure it is a polarized outlet. The machine has a polarized plug (one blade of plug is wider than the other blade) that will accept a polarized extension cord. The extension cord will fit into a polarized outlet (receptacle) only one way. If plug does not fit fully into your outlet, reverse the plug. If it still does not fit, contact a qualified electrician to install a proper polarized outlet. **DO NOT** modify or change this polarized plug in any way.

IMPORTANT! Electric Start Kit optional accessory on some models.

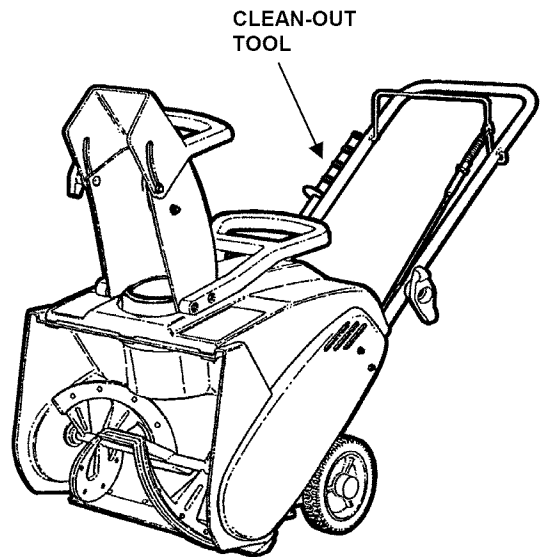

FIGURE 2.4

Section 2 - OPERATING INSTRUCTIONS

2.2 STARTING, STOPPING & OPERATION (RECOIL START MODELS)

2.2.1. ENGINE & AUGER

1. Move choke control to the choke "ON" position.
See Figure 2.5.

NOTE: Stop the auger by releasing the auger control.
Stop the engine by turning the key switch to the "OFF" position.

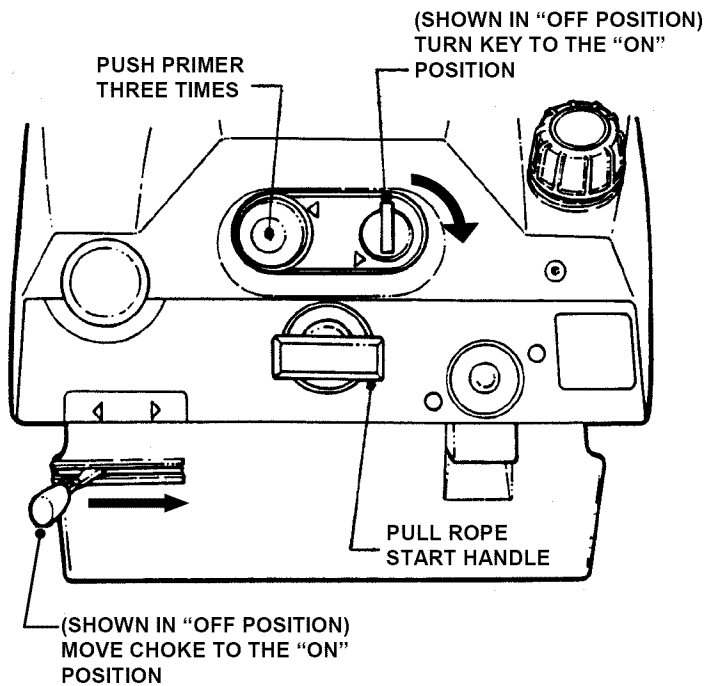

FIGURE 2.5

2. Turn ignition key to the "ON" position.
3. Push primer button three times to start a cold engine. **NOTE:** Do not use primer button to start warm engine.
4. Pull rope start handle to crank engine.
5. After engine starts, move the choke control to the no choke "OFF" position. Allow a brief warm-up until engine runs smooth.

WARNING

Release auger clutch control and make sure auger/impeller has STOPPED before rotating discharge chute or adjusting deflector. DO NOT place hands near auger/impeller while engine is running.

2.2.3. DISCHARGE CHUTE and DEFLECTOR ADJUSTMENT

1. Release auger control and allow auger to come to a complete stop before performing any adjustments.
2. Loosen deflector knob and position deflector to desired angle. Retighten knob.
3. Rotate discharge chute in desired direction. See Figure 2.7.

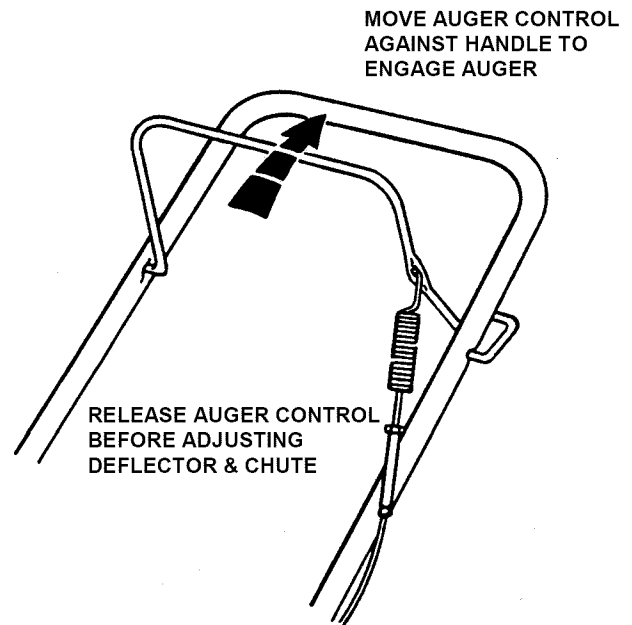

FIGURE 2.6

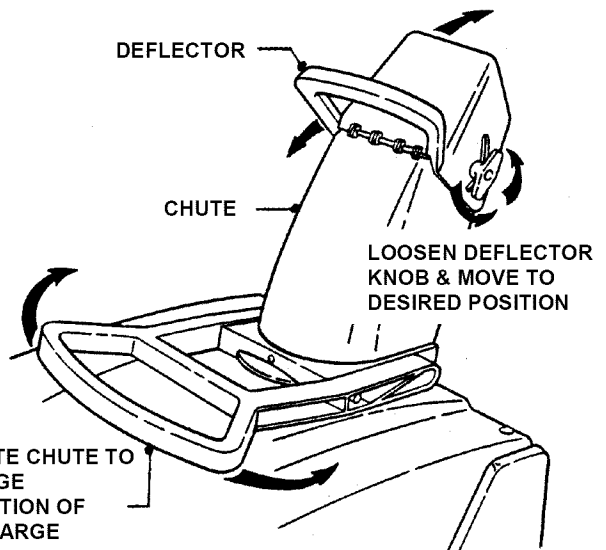

FIGURE 2.7

WARNING

Objects can be thrown by the snow thrower while it is in operation. Thrown objects could cause serious injury to the operator or bystanders. Always wear safety goggles or other suitable eye protection. Keep people and pets away from area.

2.2.2. ENGAGING AUGER

1. Pull auger control against handle to engage auger. See Figure 2.6.

Section 2 - OPERATING INSTRUCTIONS

2.2.4. STOPPING

Stop the auger by releasing the auger control. Stop the engine by turning the key switch to the "OFF" position. Always remove key from key switch before leaving machine unattended. See Figure 2.8.

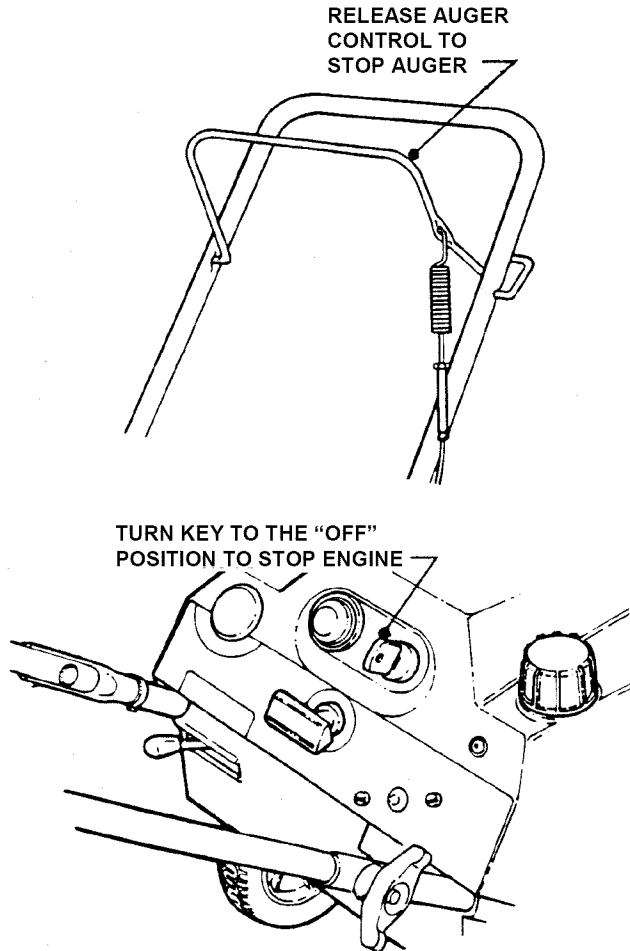

FIGURE 2.8

2.2 STARTING, STOPPING & OPERATION (ELECTRIC START MODELS)

2.2.5. ENGINE & AUGER

1. Connect the power cord to the starter switch box on machine's control panel then plug the other end into 120 volt AC receptacle.
2. Turn ignition key to the "ON" position.
3. Move choke control to the choke "ON" position. See Figure 2.9.
4. Push primer button three times to start a cold engine. **NOTE:** Do not use primer button to start warm engine.
5. Push the electric starter button. **DO NOT** hold button for more than 20 seconds to avoid damaging the starting motor. See Figure 2.9.
6. After engine starts, move the choke control to the no choke "OFF" position. Allow a brief warm-up until engine runs smooth.
7. Disconnect power cord from AC receptacle. Disconnect power cord from machine and remove cord from area where machine will be in operation.

NOTE: Stop the auger by releasing the auger control. Stop the engine by turning the key switch to the "OFF" position.

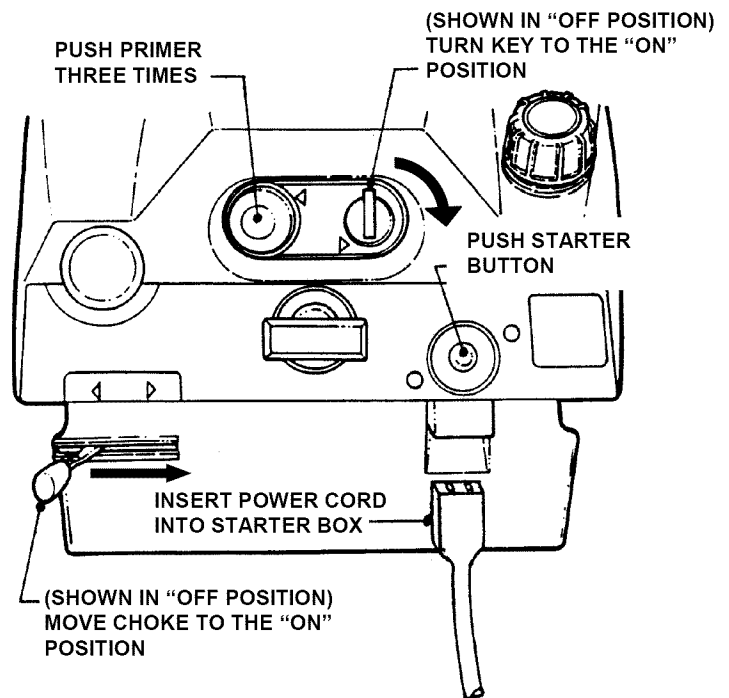



FIGURE 2.9

⚠ WARNING ⚠



DO NOT use an electrical extension cord that is damaged. A damaged electrical extension cord could cause a shock or fire. Thoroughly inspect electrical extension cord before using machine. If cord is damaged, do not use and do not operate machine. Replace damaged cord immediately. Contact your SNAPPER service dealer for assistance. To reduce the risk of electric shock, use only with an extension cord intended for outdoor use having a cord type: SW-A, SOW-A, STW-A, STOW-A, SJW-A, SJTW-A or SJTOW-A.

Section 2 - OPERATING INSTRUCTIONS

 **WARNING** 
Objects can be thrown by the snow thrower while it is in operation. Thrown objects could cause serious injury to the operator or bystanders. Always wear safety goggles or other suitable eye protection. Keep people and pets away from area.

2.2.6. ENGAGING AUGER

1. Pull auger control against handle to engage auger. See Figure 2.6.

 **DANGER** 
DO NOT clean out discharge chute with hands. Contact with moving parts inside chute will cause serious injury. Use clean out tool provided with machine.

 **WARNING** 
Release auger clutch control and make sure auger/impeller has STOPPED before rotating discharge chute or adjusting deflector. DO NOT place hands near auger/impeller while engine is running.

2.2.7. DISCHARGE CHUTE and DEFLECTOR ADJUSTMENT

1. Release auger control and allow auger to come to a complete stop before performing any adjustments.
2. Loosen deflector knob and position deflector to desired angle. Retighten knob.
3. Rotate discharge chute in desired direction. See Figure 2.7.

2.2.8. STOPPING

Stop the auger by releasing the auger control. Stop the engine by turning the key switch to the "OFF" position. Always remove key from key switch before leaving machine unattended. See Figure 2.8.

Section 3 - MAINTENANCE

3.1 INTRODUCTION

To retain the quality of the snow thrower, use genuine SNAPPER replacement parts only. Contact a local SNAPPER dealer for parts and service assistance. For the correct part or information for a particular snow thrower, always mention model and serial number.

3.2 SERVICE - AFTER FIRST 5 HOURS

3.2.1 CHECK AUGER DRIVE BELT

1. Visually check engine drive belt for cracking, fraying, severed or exposed belt strands. Replace worn belt before operating snow thrower. See Figure 3.1

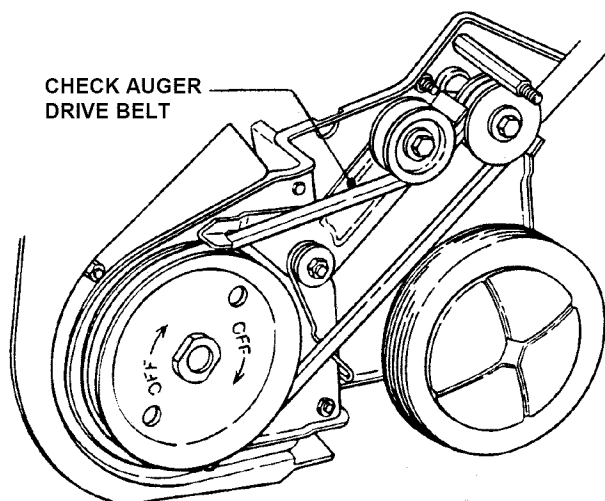

FIGURE 3.1

3.2.2 CHECK AUGER FLITE SHOE

1. Visually check flite shoes for cracking, fraying severed or exposed belt strands. Replace worn flite shoes before operating snow thrower. See Figure 3.2.

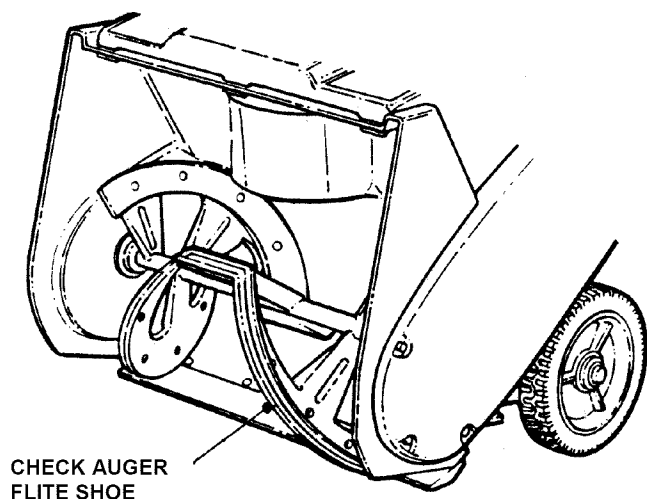

FIGURE 3.2

3.2.3 CHECK AUGER CLUTCH CONTROL CABLE

1. Visually check cable for fraying, kinking or severed cable strands. Replace cable and adjust tension before operating snow thrower. See Figure 3.3.

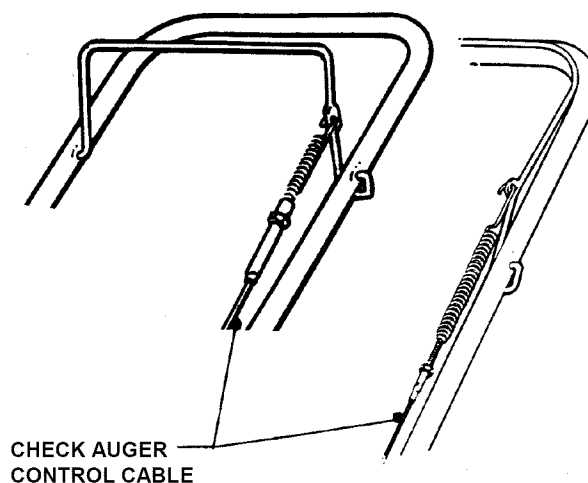

FIGURE 3.3

3.3 ANNUALLY (END OF EACH SEASON)

Perform all maintenance as described in the maintenance schedule.

3.3.1. Engine

Refer to engine owner's manual for service instructions.

3.3.2. Spark Plug

Refer to engine owner's manual for service instructions.

3.4 STORAGE PROCEDURE

Refer to the Engine Owner's Manual for directions regarding engine storage preparations. Prepare the snow thrower for "end of season" storage as follows:

1. Drain fuel from fuel tank and let engine run until all fuel is out of the carburetor.
2. **Disconnect and remove the spark plug wire away from spark plug before any other preparations are made!**
3. Tape all openings closed to prevent spraying water into exhaust or air intakes during washing.
4. Tilt snow thrower up on its wheels and thoroughly clean the underside of the auger.
5. Lubricate all exposed metal with a light coating of oil to prevent corrosion. **DO NOT** place any type of lubrication onto belt or pulleys.
6. Store the machine in a shed or other dry area, protected from weather.

Section 4 - REPAIR & ADJUSTMENTS



WARNING



DO NOT attempt any adjustments, maintenance, service, or repairs with engine running. Stop auger. Stop engine. Remove key. Remove spark plug wire and secure wire away from spark plug.

4.1 AUGER BELT ADJUSTMENT/REPLACEMENT

When operating machine release the auger clutch control. The auger should come to a complete stop in 5 seconds. If the auger does not come to a complete stop in the required time, check and adjust belt tension. Inspect belt frequently for signs of excessive wear. Observe drive belt for slippage due to wear when operating machine. If slippage does occur adjust as follows.

4.1.1. AUGER BELT CABLE ADJUSTMENT

1. Measure control cable extension from a relaxed position to full extended position. Move control lever against handle. Measure the overall length of the spring. The length of the cable spring should increase by 1/2" to 3/4" when the clutch control is depressed. See Figure 4.1.

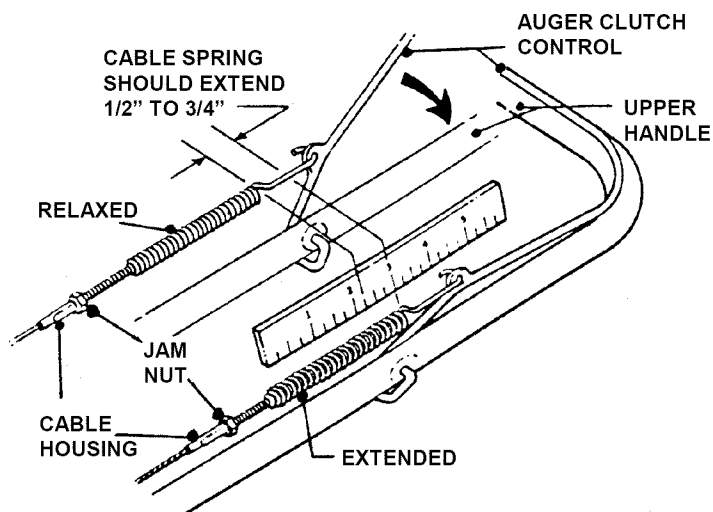

FIGURE 4.1

2. Loosen jam nut at the upper end of cable. Hold threaded end of cable and then turn cable clockwise until correct extension is achieved. Retighten jam nut.

IMPORTANT: DO NOT over tighten cable. The control cable must have slack for the auger brake to function properly. If the auger control cannot be properly adjusted, belt adjustment and/or replacement will be required. Refer to Section "Auger Belt Idler Pulley Adjustment".

4.1.2. AUGER BELT IDLER PULLEY ADJUSTMENT

NOTE: To adjust the idler pulley and properly tension the auger belt, the auger control cable adjustment must first be loosened as described in the following step. Cable adjustment must be checked after completing the idler pulley adjustment.

1. Loosen jam nut at the upper end of cable. Hold threaded end of cable and then turn metal housing of cable counter clockwise until threaded portion of cable is extracted from metal housing. Reinstall 1/2" of the threaded portion of cable back into metal housing. Retighten jam nut.
2. Remove belt cover. See Figure 4.2

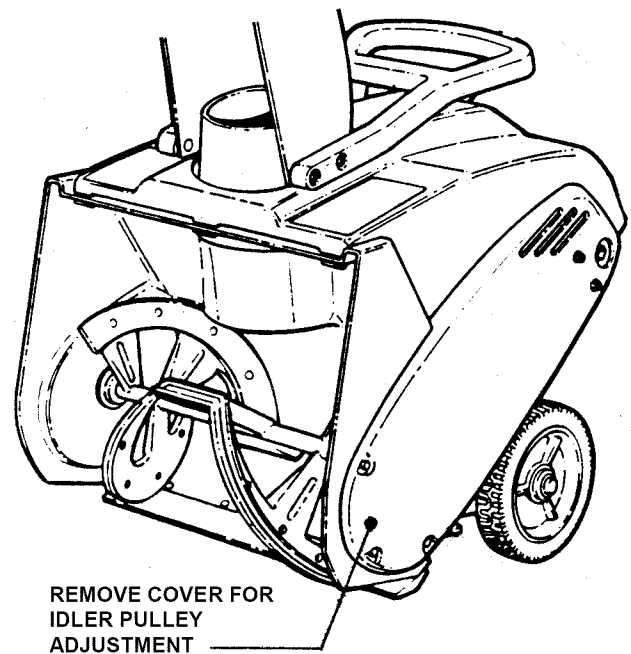

FIGURE 4.2

(Continued on the Next Page)

Section 4 - REPAIR & ADJUSTMENTS

WARNING
DO NOT attempt any adjustments, maintenance, service, or repairs with engine running. Stop auger. Stop engine. Remove key. Remove spark plug wire and secure wire away from spark plug.

4.1.2. AUGER BELT IDLER PULLEY ADJUSTMENT (Continued From Previous Page)

3. Loosen nut and bolt that secures the idler pulley to idler arm. Move idler pulley down for more tension or up for less tension on belt. See Figure 4.3. Retighten bolt and nut securely.
4. Recheck cable for proper extension. Refer to Section "Auger Belt Cable Adjustment".
5. Reinstall belt cover.

IDLER PULLEY ASSEMBLY SHOWN EXPLODED TO SHOW DETAIL OF IDLER ARM SLOT

MOVE IDLER PULLEY UP TO DECREASE OR DOWN TO INCREASE TENSION ON BELT

BELT COVER RETAINING STUDS

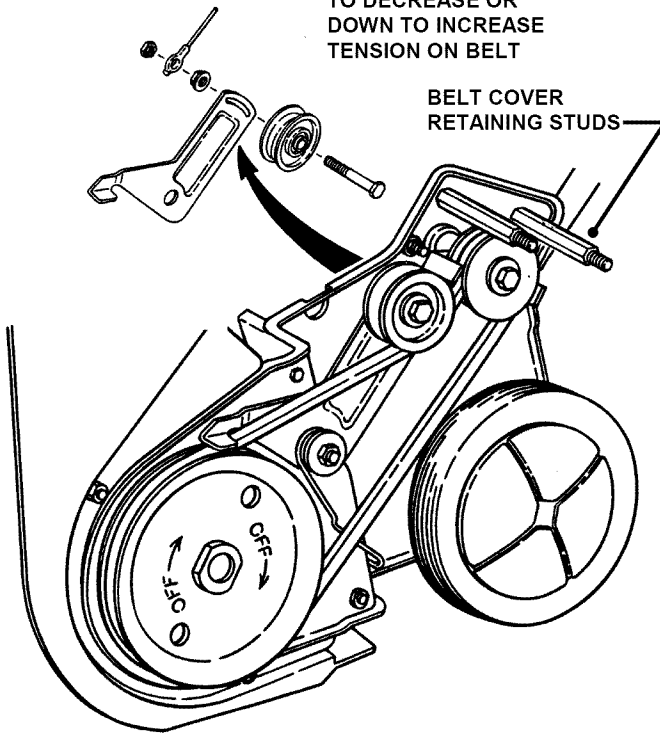

FIGURE 4.3

4.1.3. AUGER BELT REPLACEMENT

Inspect belt frequently for signs of excessive wear. Visually check engine drive belt for cracking, fraying, severed or belt strands exposed.

1. Remove belt cover. See Figure 4.2.
2. Remove both belt cover retaining studs.
2. Remove belt guide. See Figure 4.4.
3. Push the spring tensioned idler pulley down and remove belt.

4. Push the spring tensioned idler pulley down and install new belt. See Figure 4.5.

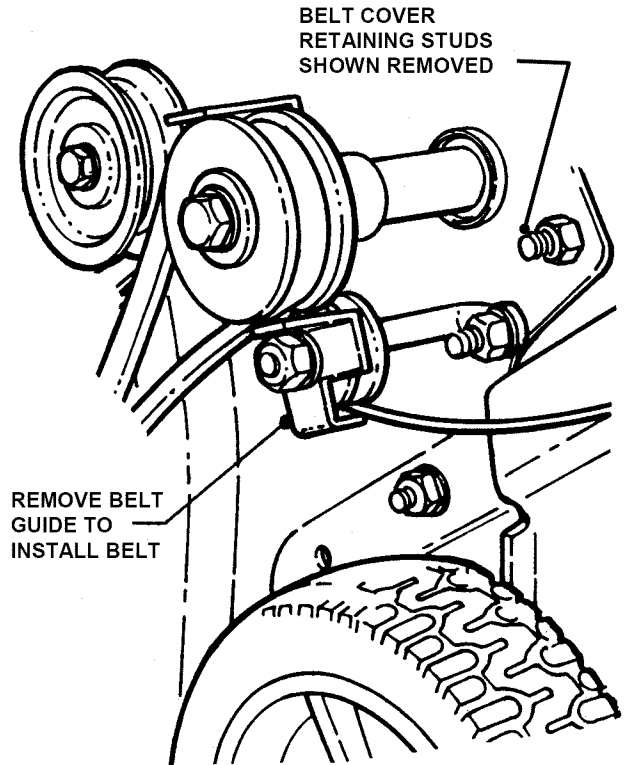

FIGURE 4.4

PUSH IDLER DOWN TO REMOVE & INSTALL AUGER BELT

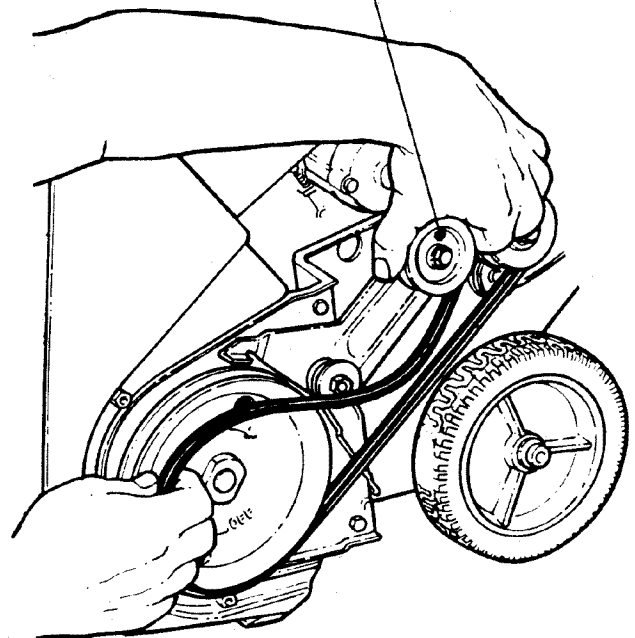

FIGURE 4.5

Section 4 - REPAIR & ADJUSTMENTS



WARNING



DO NOT attempt any adjustments, maintenance, service, or repairs with engine running. Stop auger. Stop engine. Remove key. Remove spark plug wire and secure wire away from spark plug.

4.1.3. AUGER BELT REPLACEMENT (Continued From Previous Page)

5. Reinstall belt guide.

IMPORTANT: Make sure when reinstalling belt guide that it does not touch drive pulley. Belt guide should have an equal amount of clearance on both belt guide fingers. See Figure 4.6.

6. Refer to Section "Auger Belt Adjustment/Replacement".

7. Reinstall belt cover and tighten screws securely. DO NOT overtighten.

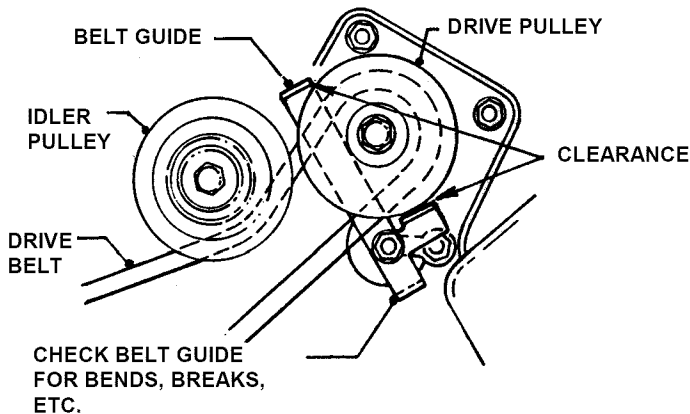

FIGURE 4.6

4.1.4. AUGER FLITE SHOE REPLACEMENT

Inspect flite shoes frequently for signs of excessive wear. Visually check flite shoes for cracking, fraying, severed or belt strands exposed. #6-1215 Flite Shoe Kit for 17" Auger Models and #6-1213 Flite Shoe Kit for 19" Auger Models. These kits will be required to replace existing flite shoes.

1. Tilt machine backward to gain access to auger. Secure machine in the tilted position to prevent tipping over.

2. Remove all self-tapping screws that secure the flite shoes to auger. Save screws for future use.

3. Install new flite shoes to auger using self-tapping screws removed previously. Tighten screws securely. DO NOT overtighten. See Figure 4.7.

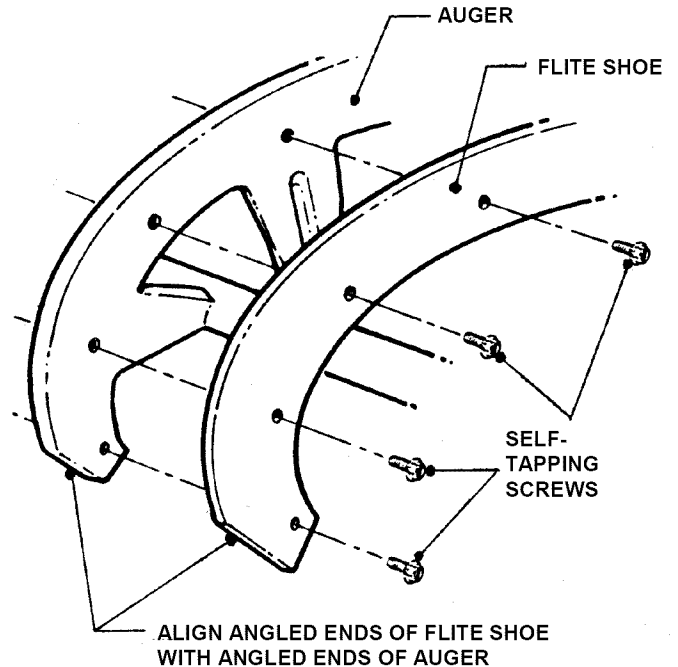

FIGURE 4.7

TROUBLESHOOTING

PROBLEM	PROBABLE CAUSE	CORRECTIVE ACTION
Engine Will Not Start Using Recoil Starter	1. Fuel tank empty.	1. Fill fuel tank with fresh fuel/oil mix.
	2. Engine needs choking & priming.	2. Move choke control to "CHOKE" position. Push primer bulb three times.
	3. Spark plug fouled or wire disconnected.	3. Replace spark plug. Attach plug wire onto spark plug.
Engine Will Not Crank Using Electric Starter	1. Power extension cord not plugged into machine or 110 Volt outlet.	1. Plug power extension cord into machine & into 110 Volt outlet.
	2. Power extension cord damaged.	2. Discard damaged power extension cord
	3. Starter switch damaged or faulty.	3. Replace starter switch.
	4. Key switch turned to "OFF" position.	4. Turn key switch to "ON" position.
Engine Stalls or Stops After Running	1. Fuel and 2-Cycle oil mixture ratio incorrect.	1. Mix fuel and 2-Cycle oil to 50:1 ratio.
	2. Choke control in the "CHOKE" position.	2. Move choke control to "OFF" position.
	3. Fuel tank empty.	3. Fill with fuel to proper level.
	4. Air intake clogged with snow or debris.	4. Unclog air intake.
	5. Spark plug defective or gap set improperly.	5. Service spark plug.
	6. Water, debris or stale fuel in fuel system.	6. Drain and clean fuel system.
	7. Fuel filter clogged.	7. Replace with new in line filter.
Engine Loses Power	1. Fuel and 2-Cycle oil mixture ratio incorrect.	1. Mix fuel and 2-Cycle oil to 50:1 ratio.
	2. Spark plug faulty.	2. Service spark plug.
	3. Water, debris or stale fuel in fuel system.	3. Drain and clean fuel system.
Excessive Vibration	1. Damaged, out of balance or bent auger.	1. Service auger.
	2. Loose engine or auger components.	2. Service and tighten loose components.
	3. Loose or missing flightings.	3. Replace flightings.
	4. Cracked, severed or frayed belt	4. Replace belt.
	5. Bent or loose Idler pulley	5. Tighten or replace pulley.
Poor Snow Discharging	1. Clogged discharge chute.	1. Stop engine and unclog discharge chute.
	2. Damaged or bent auger or components.	2. Service auger or components.
	3. Cracked, severed or frayed belt.	3. Replace belt.
	4. Belt tension out of adjustment.	4. Adjust belt tension.
	5. Auger flightings damaged or missing.	5. Replace flightings.

SERVICE SCHEDULE

ITEM	SERVICE PERFORMED	REF.	EACH USE	5 HRS	25 HRS	50 HRS	100 HRS	EACH SEASON
Spark Plug	Replace	Engine Manual.					X	
Engine Cooling System	Clean Shroud & Fins	Engine Manual					X	
Drive Belts	Check For Wear And Tension	Page 11-14			X	X		X
Auger & Flight Shoe	Check For Wear, Damage & Replacement	Page 11, 14	X					

4.2. MAINTENANCE/REPLACEMENT PARTS

MAINTENANCE PARTS	
Auger Drive Belt	7024618
Auger Clutch Control Cable	7024662
Auger Flite Shoe Kit for 17" Auger Models	7061215
Auger Flite Shoe Kit for 19" Auger Models	7061213
Parts Manual for L.E. Models Series 1 Snow Thrower Models: LE3171R, LE3191R, LE3191E	7006030

SNAPPER®

2 YEAR LIMITED WARRANTY

For two (2) years from purchase date for the original purchaser's residential, non-commercial use, **SNAPPER**, through any authorized **SNAPPER** dealer will replace, free of charge (except for taxes where applicable), any part or parts found upon examination by the factory at McDonough, Georgia, to be defective in material or workmanship or both.

For ninety (90) days from purchase date for the original purchaser's commercial, rental, or other non-residential use, **SNAPPER**, through any authorized **SNAPPER** dealer will replace, free of charge, any part or parts found upon examination by the factory at McDonough, Georgia, to be defective in material or workmanship or both.

All transportation costs incurred by the purchaser in submitting material to an authorized **SNAPPER** dealer for replacement under this warranty must be paid by the purchaser.

This warranty does not apply to certain transmissions, to engines and their components, and batteries, as these items are warranted separately. This warranty does not apply to parts that have been damaged by accident, alteration, abuse, improper lubrication, normal wear, or other cause beyond the control of **SNAPPER**. This warranty does not cover any machine or component part that has been altered or modified changing safety, performance, or durability.

Batteries have a one (1) year warranty period with free replacement if required for one (1) year from the original purchase date. **SNAPPER** will not be responsible for any installation cost incurred. The battery warranty only covers original equipment batteries and does not cover damage to the battery or machine caused by neglect or abuse, destruction by fire, explosion, freezing, overcharging, improper maintenance, or use of improper electrolyte.

There is no other express warranty.

DISCLAIMER OF WARRANTY

Implied warranties, including those of merchantability and fitness for a particular purpose, are limited to two (2) years from purchase date for the original purchaser's residential or other non-commercial use, and ninety (90) days from purchase for the original purchaser's commercial, rental or other non-residential use, and to the extent permitted by law, any and all implied warranties are excluded. This is the exclusive remedy. Liabilities for consequential damages, under any and all warranties are excluded.

Some states do not allow limitations on how long an implied warranty lasts, or do not allow the exclusion or limitation of incidental or consequential damages, so the above limitation or exclusion may not apply to you.

This warranty gives you specific legal rights, and you may also have other rights which vary from state to state.

WARNING: THE USE OF REPLACEMENT PARTS OTHER THAN GENUINE SNAPPER PARTS MAY IMPAIR THE SAFETY OF SNAPPER PRODUCTS AND WILL VOID ANY LIABILITY AND WARRANTY BY SNAPPER ASSOCIATED WITH THE USE OF SUCH PARTS.

IMPORTANT: Please fill out the attached **SNAPPER** Product Registration Card immediately and mail to:
Snapper's Product Registration Center, P.O. Box 1379, McDonough, Georgia 30253

SNAPPER PRODUCT REGISTRATION FORM

**IMPORTANT: KEEP THIS INFORMATION FOR YOUR PERSONAL RECORDS
(Complete the following information on your Snapper purchase)**

Model Number _____

Serial Number _____

Date of Purchase _____

Retailer _____

Retailer's Phone Number _____

It is very important that you register your purchase with Snapper to ensure warranty coverage. Please mail your product registration card to:

Snapper at P.O. Box 1379, McDonough, Georgia 30253.

Or you may register on line at www.snapper.com.

You can contact us at our web site or if you would like to speak with a Customer Service Representative. Call us at the Snapper Customer Relations Center. For faster service please have your Serial Number and Model Number available.

Call the Snapper Customer Relations Center at 1-800-935-2967.

Safety Instructions & Operator's Manual for

SNAPPER®

L.E. SINGLE STAGE SMALL FRAME SNOW THROWER SERIES 1

IMPORTANT

Snapper products are built using engines that meet or exceed all applicable emissions requirements on the date manufactured. The labels on those engines contain very important emissions information and critical safety warnings. Read, Understand, and Follow all warnings and instructions in this manual, the engine manual, and on the machine, engine and attachments. If you have any questions about your Snapper product, contact your local authorized Snapper dealer or contact Snapper Customer Service at Snapper, McDonough, GA. 30253. Phone: (1-800-935-2967).



WARNING

BATTERY POSTS, TERMINALS AND RELATED ACCESSORIES CONTAIN LEAD AND LEAD COMPOUNDS, CHEMICALS KNOWN TO THE STATE OF CALIFORNIA TO CAUSE CANCER AND BIRTH DEFECTS OR OTHER REPRODUCTIVE HARM. WASH HANDS AFTER HANDLING.



WARNING

ENGINE EXHAUST, SOME OF ITS CONSTITUENTS, AND CERTAIN VEHICLE COMPONENTS CONTAIN OR EMIT CHEMICALS KNOWN TO THE STATE OF CALIFORNIA TO CAUSE CANCER OR OTHER REPRODUCTIVE HARM.

SNAPPER® McDonough, GA., 30253 U.S.A.

www.snapper.com

COPYRIGHT © 2006
SNAPPER – A DIVISION OF SIMPLICITY MFG., INC.
ALL RIGHTS RESERVED

INSTRUCTION No. 7100947 (I.R. 6/26/2006)
TP 100-5205-00-SX-SN