

Save This Manual
For Future Reference

SEARS

owners
manual

MODEL NO.
171.25490

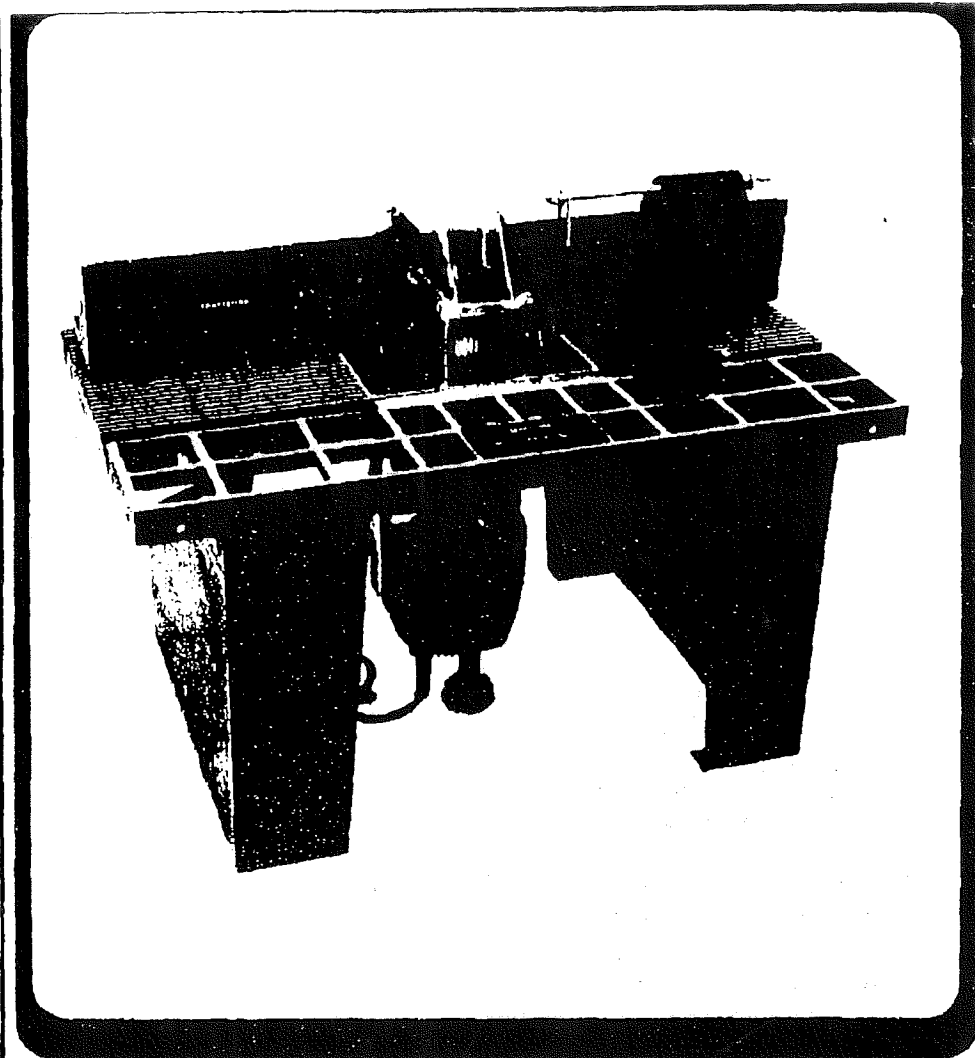

CRAFTSMAN

INDUSTRIAL ROUTER TABLE

CAUTION:
READ ALL
INSTRUCTIONS
CAREFULLY

- assembly
- operating

Sold by SEARS, ROEBUCK AND CO., CHICAGO, IL 60684 U.S.A.

Printed in U.S.A.

49LCN-39

WARNING: FAILURE TO HEED ALL SAFETY AND OPERATING INSTRUCTIONS AND WARNINGS REGARDING USE OF THIS PRODUCT CAN RESULT IN SERIOUS BODILY INJURY.

GENERAL SAFETY INSTRUCTIONS FOR POWER TOOLS

- 1. KNOW YOUR POWER TOOL**
Read the owner's manual carefully. Learn its application and limitations as well as the specific potential hazards peculiar to this tool.
- 2. GROUND ALL TOOLS (UNLESS DOUBLE INSULATED)**
If tool is equipped with an approved 3-conductor cord and a 3-prong grounding type plug to fit the proper grounding type receptacle. The green conductor in the cord is the grounding wire. Never connect the green wire to a live terminal.
- 3. KEEP GUARDS IN PLACE**
in working order, and in proper adjustment and alignment.
- 4. REMOVE ADJUSTING KEYS AND WRENCHES**
Form habit of checking to see that keys and adjusting wrenches are removed from tool before turning it on.
- 5. KEEP WORK AREA CLEAN**
Cluttered areas and benches invite accidents. Floor must not be slippery due to wax or sawdust.
- 6. AVOID DANGEROUS ENVIRONMENT**
Don't use power tools in damp or wet locations or expose them to rain. Keep work area well lighted. Provide adequate surrounding work space.
- 7. KEEP CHILDREN AWAY**
All visitors should be kept a safe distance from work area.
- 8. MAKE WORKSHOP KID-PROOF**
— with padlocks, master switches, or by removing starter keys.
- 9. DON'T FORCE TOOL**
It will do the job better and safer at the rate for which it was designed.
- 10. USE RIGHT TOOL**
Don't force tool or attachment to do a job it was not designed for.
- 11. WEAR RIGHT APPAREL**
Do not wear loose clothing, gloves, neckties or jewelry (rings, wrist watches) to get caught in moving parts. Non-slip footwear is recommended. Wear protective hair covering to contain long hair. Roll long sleeves above the elbow.
- 12. USE SAFETY GOGGLES (Head Protection)**
Wear Safety goggles (must comply with ANS Z87.1) at all times. Also use face or dust mask if cutting operation is dusty, and ear protectors (plugs or muffs) during extended periods of operation.
- 13. SECURE WORK**
Use clamps or a vise to hold work when practical. It's safer than using your hand. Frees both hands to operate tool.
- 14. DON'T OVERREACH**
Keep proper footing and balance at all times.
- 15. MAINTAIN TOOLS WITH CARE**
Keeps tools sharp and clean for best and safest performance. Follow instructions for lubricating and changing accessories.
- 16. DISCONNECT TOOLS**
before servicing; when changing accessories such as blades, bits, cutters, etc.
- 17. AVOID ACCIDENTAL STARTING**
Make sure switch is in "OFF" position before plugging in.
- 18. USE RECOMMENDED ACCESSORIES**
Consult the owner's manual for recommended accessories. Follow the instructions that accompany the accessories. The use of improper accessories may cause hazards.
- 19. NEVER STAND ON TOOL**
Serious injury could occur if the tool is tipped or if the cutting tool is accidentally contacted.

Do not store materials above or near the tool such that it is necessary to stand on the tool to reach them.
- 20. CHECK DAMAGED PARTS**
Before further use of the tool, a guard or other part that is damaged should be carefully checked to ensure that it will operate properly and perform its intended function. Check for alignment of moving parts, binding of moving parts, breakage of parts, mounting, and any other conditions that may affect its operation. A guard or other part that is damaged should be properly repaired or replaced.
- 21. DIRECTION OF FEED**
Feed work into a blade or cutter against the direction of rotation of the blade or cutter only.
- 22. NEVER LEAVE TOOL RUNNING UNATTENDED**
Turn power off. Don't leave tool until it comes to a complete stop.

1. ALWAYS USE EYE PROTECTION

The operation of any power tool can result in foreign objects being thrown into the eyes, which can result in severe eye damage. Always wear safety goggles before commencing power tool operation. Safety goggles are available at Sears retail or catalog stores.

2. KEEP HANDS CLEAR OF BITS, AND WORKING AREA.

3. MAKE AND USE A PUSH STICK TO MOVE SMALL WORKPIECES ACROSS THE CUTTING AREA.

4. KEEP ROUTER CLEAN AFTER EVERY USE, CLEAN SAW DUST OF THE ROUTER. (ALSO BLOW OUT INSIDE).

5. YOUR ROUTER TABLE IS PROVIDED WITH A DUST COLLECTING ATTACHMENT. ALWAYS USE SHOP VAC FOR ALL ROUTING OPERATIONS.

NOTE: Motors used on wood-working tools are particularly susceptible to the accumulation of sawdust and wood chips, and should be blown out, or "vacuumed", frequently to prevent interference with normal motor ventilation.

6. CHECK FUNCTION OF GUARD BEFORE EACH USE. REMOVE ALL DUST AND CHIPS FROM GUARD AREA AS NEEDED TO MAINTAIN GUARD FUNCTION.

7. NEVER PUT YOUR FINGERS UNDER THE GUARD WHEN THE ROUTER IS PLUGGED IN.

8. ALWAYS USE THE ROUTER TABLE FENCE TO GUIDE THE WORK. DO NOT WORK FREEHAND.

When using the pilot type bits, keep the fences as close to the pilot as possible to provide additional backup and additional guidance and to avoid chances of an accident and possible personal injury.

9. ALWAYS USE THE STARTING PIN AND PILOTTED BITS FOR FREE HAND ROUTING IRREGULAR SHAPED WORKPIECES.

10. ALWAYS FEED AGAINST THE ROTATION OF THE CUTTER WHEN ROUTING ON THE ROUTER TABLE.

11. WHEN END CUTTING ON WORKPIECES 4" WIDE OR LESS, CLAMP AND HOLD AND FEED THE WORKPIECE WITH THE PUSH BLOCK USING BOTH HANDS AS SHOWN IN FIG. #25. KEEP FINGERS CLEAR OF BIT WHEN MOVING WORKPIECE ACROSS THE CUTTING AREA.

12. ROUTER BITS ARE EXTREMELY SHARP.
Be extra careful when working around them.

13. SOME ROUTERS WHEN USED IN AN UPSIDE DOWN POSITION SUCH AS ON A ROUTER TABLE WILL FALL (OR DROP) OUT OF THE ROUTER BASE WHEN THE BASE CLAMP IS LOOSENED, IT IS THEREFORE ABSOLUTELY NECESSARY TO SUPPORT THE ROUTER MOTOR FROM BELOW WHEN THE BASE CLAMP IS LOOSENED TO MAKE ADJUSTMENTS, OR FOR ANY OTHER REASON.

14. ALWAYS LOOK UNDER THE TABLE AT THE SWITCH WHEN TURNING THE ROUTER ON/OFF AND TOUCH NOTHING BUT THE SWITCH. NEVER REACH UNDER THE TABLE WHEN ROUTER IS RUNNING FOR ANY OTHER REASON.

NOTE: It is far safer and convenient to use a "Sears Craftsman 925060 Router Table Switch Package". This switch provides a key operated ON/OFF button which allows very fast and easy access when and if it becomes necessary to turn the router "OFF" quickly. The key can be removed to render the switch inoperable to unauthorized people.

15. ONCE GUARD IS INSTALLED FOR ROUTING, DO NOT REMOVE FOR ANY REASON.

16. MOUNT ROUTER TABLE FIRMLY AND SECURELY TO A WORK SURFACE BEFORE USE. FAILURE TO DO SO COULD CAUSE TABLE TO TIP OVER OR SLIDE DURING OPERATION RESULTING IN PROPERTY DAMAGE AND/OR SERIOUS BODILY INJURY.

17. WARNING
BEFORE MAKING ANY CUT, UNPLUG ROUTER AND MAKE ABSOLUTELY SURE THAT THE GUARD CLEARS THE ROUTER BIT AND IS FUNCTIONING NORMALLY.

18. WARNING:
ROUTER VIBRATIONS SOMETIMES CAN CAUSE FASTENERS FOR THE TABLE, THE ROUTER AND THE UNITIZED FENCE TO GET LOOSE! PERIODICALLY CHECK FASTENERS TO MAKE SURE THEY ARE TIGHT AND SECURE.

INTRODUCTION

How often have you needed a large guiding surface on a router table? Your Sears Craftsman Industrial Router Table with Unitized Fence comes with:

- a. A unique 4" high unitized fence designed to assist end grain routing for making tenons, sliding dovetails and tongue and groove joints along with most edge and face cutting operations.
- b. A specially designed push block with quick clamp for back up and clamping boards up to 4" width for end grain routing.
- c. An accurate and quick adjusting jointing fence adjustable to proper jointing depth of cut.
- d. A unitized fence designed to enable routing operations like grooving; fluting; veining; crown molding etc. up to 2 1/2" away from the edge toward the middle of the board.

- e. Dust collecting attachment for most shop vac hook ups.

To increase the work surface of your router table, "Sears Craftsman 925212 Industrial Router Table Extensions" are available as an optional product from Sears.

In order to simplify handling and minimize any damage that might occur during shipment, your new router table is packaged unassembled. We know you are anxious to see what your new tool will do, but a few minutes spent now carefully reading the following instructions, will result in less frustration and more enjoyable operation later.

Start by checking and accounting for all the loose parts. If any parts are missing, contact your local Sears retail or catalog outlet for replacement.

UNPACKING AND CHECKING CONTENTS

WARNING: YOU MUST READ AND UNDERSTAND ALL THE INSTRUCTIONS COMPLETELY BEFORE ATTEMPTING TO ASSEMBLE AND OPERATE YOUR ROUTER AND ROUTER TABLE.

ASSEMBLY

ASSEMBLY OF TABLE

1. Turn the table upside down.
2. Place one of the table legs at one end of the table as shown in Figure 1.
3. Insert the #10-32 x 5/8" truss head screws through the table top and leg. Six are required for each leg.

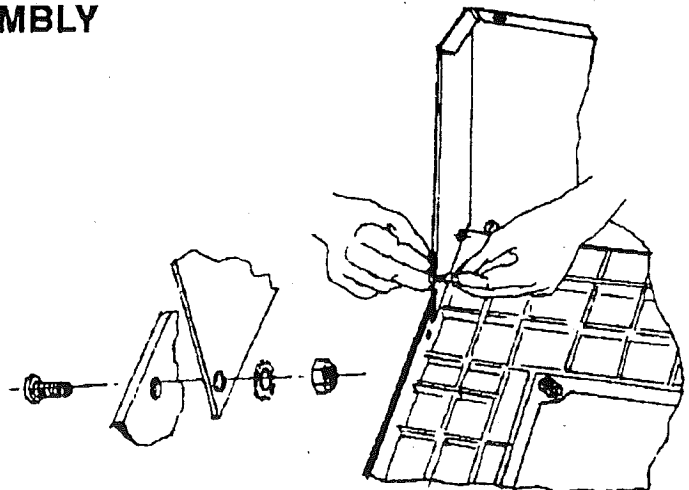

FIGURE 1.

screw. The lock washers should be against the inside of the leg.

5. Repeat for the remaining leg.
6. Turn the table right side up and tighten all 12 screws and nuts with a wrench or pliers.

ASSEMBLY OF THROAT PLATE TO TABLE

1. Assemble four #10-32 x $\frac{5}{8}$ panhead screws and four #10-32 stop nuts to table as shown in Figure 2.
NOTE: After a few turns of the screw, resistance of further turning will be experienced—this is normal. Do not tighten completely: just enough so screws protrude through nut.

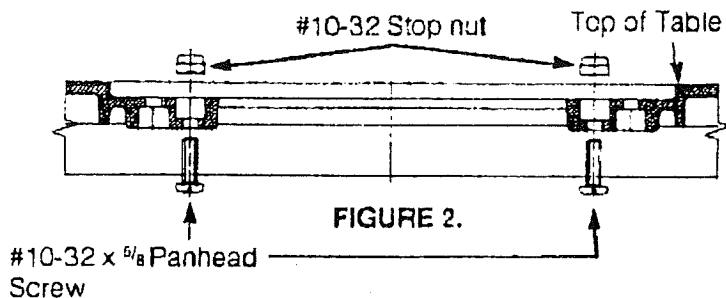

2. Place the throat plate into the large opening in the table. The position of three small holes must be as shown in Figure 3.

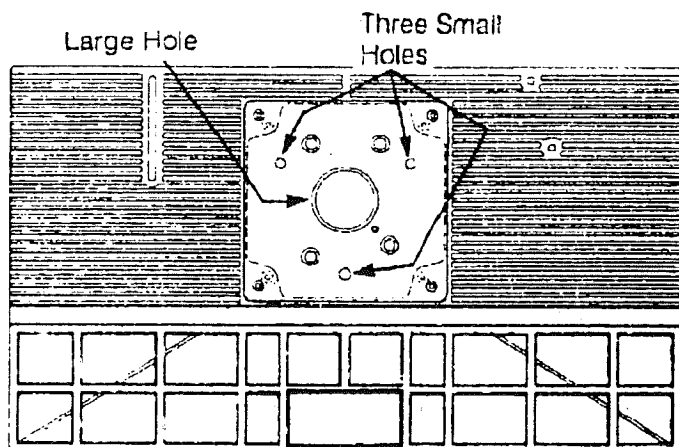

3. While pressing down on the throat plate, gradually turn the screws inward or outward until the throat plate is level with the table top. Throat plate must be stable; that is, it must rest on all four screws and not "rock" when pressure is applied. Refer to Figure 4.

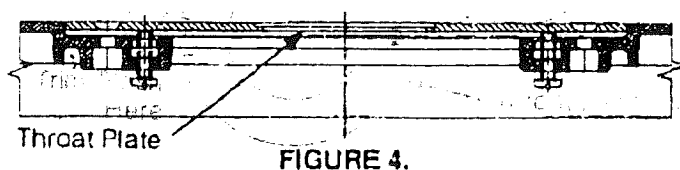

four #10-32 stop nuts to secure the throat plate to the table, as shown in Figure 5. Tighten securely.

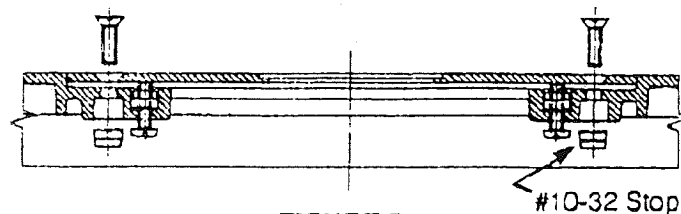

MOUNTING ROUTER TO TABLE

ALWAYS UNPLUG ROUTER BEFORE MOUNTING (The table is designed to accept most Sears Craftsman Routers. However, it will accommodate other brands with bases up to 7" in diameter by properly aligning, drilling and countersinking the required mounting holes into the throat plate).

ATTACHING SEARS ROUTERS WITH THREE HOLE BASE PLATES

1. Remove the router base plate (back plate) from the router, and put base plate and screws in a convenient place for storage.
2. While holding the router upside down, position it to the underside of the throat plate, as shown in Figure 6.

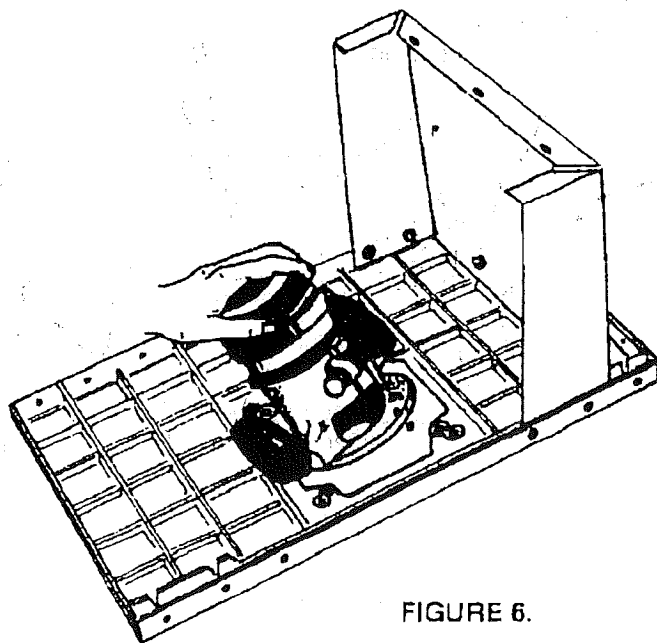

3. Rotate the router until the three mounting holes in the router base lineup with three of the holes in the throat plate. (It will be helpful if you orient the router such that you can easily reach the ON/OFF switch from the front of the table. Sears Craftsman 925090 Router Table Switch Package provides easy access to ON/OFF button).

4. Insert three #10-32 x 3/8" long flat head machine screws (provided) through holes in the throat plate and tighten securely into the router base. See Figure 7.

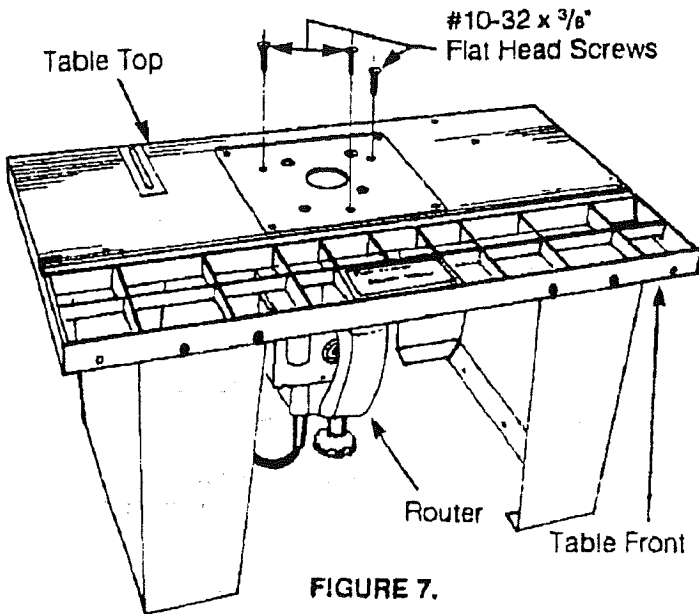

FIGURE 7.

ATTACHING SEARS ROUTER MODEL NO. 27504

Proceed as with three hole base plate routers except as follows:

In step 3, line up the four large threaded holes in the router base with the four large countersunk holes in the throat plate.

NOTE: Router will line up in one position only.

In step 4, use the four large 1" long (M8 x 25 Metric) flathead screws provided. These screws are silvery in color.

ATTACHING SEARS ROUTER MODEL NOS. 27505 AND 27506

Proceed as with three hole base plate routers except as follows:

In step 3, line up the three large threaded holes in the router base with the three corresponding large countersunk holes in the throat plate that match.

NOTE: Router will line up in one position only.

In step 4, use the three 3/16-18 x 1" long flathead screws provided. These screws are black in color.

ATTACHING OTHER BRANDS OF ROUTERS

NOTE: Routers having a total overall height of 13 inches or less and a base diameter of 7 inches or less can be accommodated.

1. If the throat plate has already been assembled to the table, remove it, IF NOT, proceed with step 2.
2. Place the throat plate on a flat surface so that the locations of the holes are shown as in Figure 3.
3. Place the router upside down next to the throat plate so that the handles are aligned as shown in Figure 8.

4. Remove the base from the router, set aside the screws, and place the base plate on the throat plate.

NOTE: DO NOT FLIP OR ROTATE THE BASE PLATE WHEN DOING THIS.

5. Position the base plate so the hole in the base plate is centered with the hole in the throat plate. It may be necessary to rotate the base plate slightly so that no hole in the plate line-ups with a hole in the throat plate.

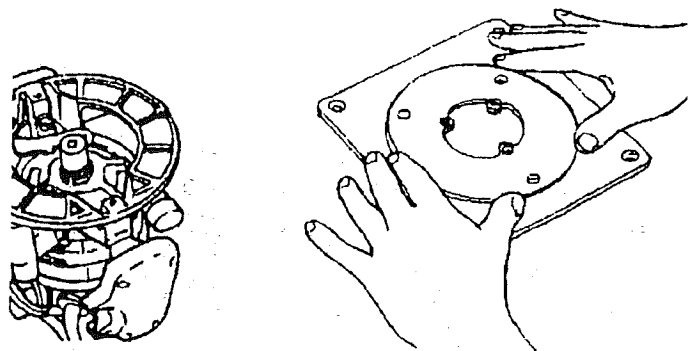

FIGURE 8.

6. Mark the position of the mounting holes on the base plate with a pencil or felt tip marker. That is, the base plate is being used as a template to locate the holes on the throat plate.

7. Select a drill bit with a diameter that is the same as or slightly bigger than the head of the screw which held the base plate on the router. (Refer to Step 4 above.)

NOTE: If the head of the screw is "V-shaped " you will be countersinking.

If the head of the screw is not "V-shaped" you will be counterboring.

8. Countersink or counterbore holes into the throat plate to a depth so the heads of the screws are slightly below the top surface of the throat plate.
9. Now select a drill bit with a diameter that is the same as or slightly bigger than the threads on the screws. Drill holes through the throat plate at the previously countersunk or counterbored holes. Use care so drill goes through the centers of these holes.
10. Assemble the throat plate to the table as described in a previous section.
11. Assemble the router to the throat plate as described above using the screws that held the base plate to the router. Put the base plate in a convenient location for storage.

With the desired bit in the router, select a throat plate insert with a center hole slightly larger than the diameter of the router bit, NOTE: For bits 1-³/₄" diameter and larger, do not use an insert.

WARNING: Do not use bits having diameters larger than 2".

The throat plate inserts are designed to be snapped into the throat plate. Slide the large tang under the edge of the large hole in the throat plate as shown in Figure 9. Using your thumb, press down on the insert until the small tang snaps into position.

To remove the insert, place the point of a small screwdriver into the slot (with the small tang) and pry the insert out of the throat plate.

SELECTING AND INSTALLING THROAT PLATE INSERTS

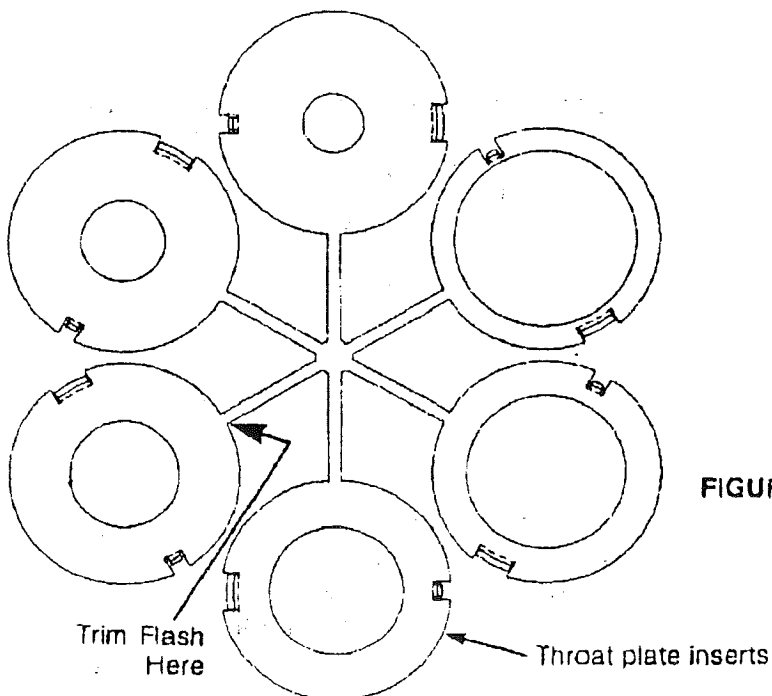

Use Screwdriver to Remove Table Insert

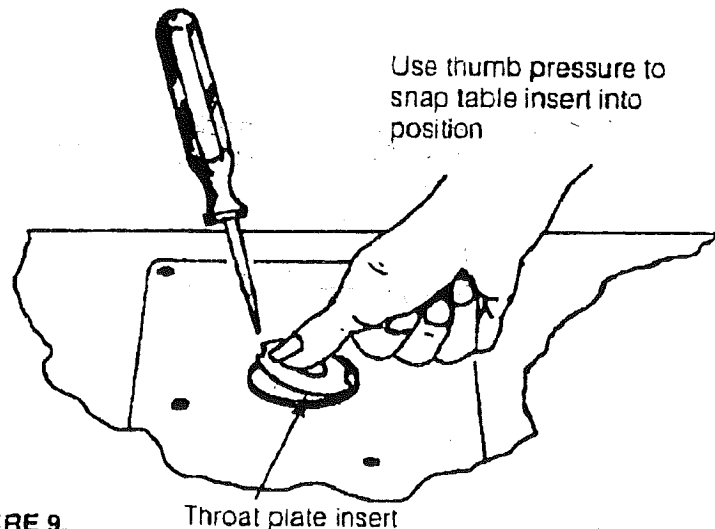

FIGURE 9.

ASSEMBLY OF UNITIZED FENCE

WARNING: BEFORE ASSEMBLING AND ATTACHING UNITIZED FENCE TO TABLE, MAKE SURE THAT ROUTER IS UNPLUGGED AND THE BIT IS BELOW THE TOP SURFACE OF THE TABLE.

ASSEMBLY OF JOINTING FENCE TO UNITIZED FENCE

1. Slide jointing fence through rectangular opening in the cavity provided on the unitized fence (V-guide on the unitized fence will slide in the V-guide on the underside of jointing fence). See Figure 10.
2. Insert $\frac{1}{4}$ -20 x 1" long hex head bolt through the hole in the unitized fence (from the underside) and the slot in the jointing fence.
3. While holding the head of the bolt in the hex recess on the underside of unitized fence, place a flat washer over the bolt and screw small $\frac{1}{4}$ -20 knob on bolt.

When knob is loosened, the jointing fence can slide back and forth in the cavity for proper jointing adjustment.

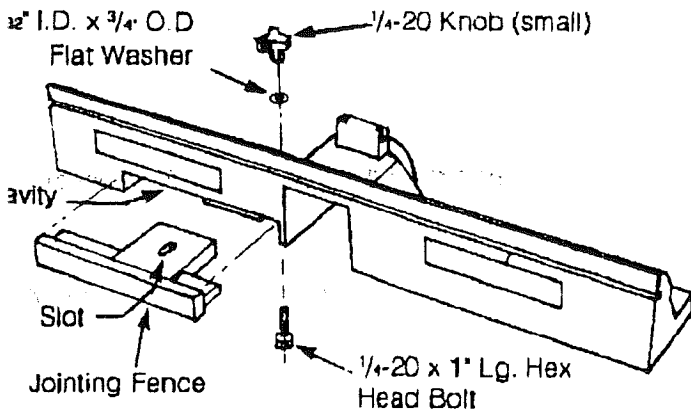

FIGURE 10.

ATTACHMENT OF UNITIZED FENCE ASSEMBLY TO TABLE

ALWAYS UNPLUG ROUTER BEFORE ATTACHING FENCE TO OR REMOVING IT FROM TABLE.

You will observe as you face the front of the table, that on the right side of the table top there are two round holes approximately $\frac{9}{32}$ " in diameter, and on the left side, there is a 4" long slot. These are used to attach the fence to the table.

For all edge cutting and end cutting operations, attach fence using the front hole and the slot. See Figures 11 and 12 for available fence adjustment on either side of the router bit center.

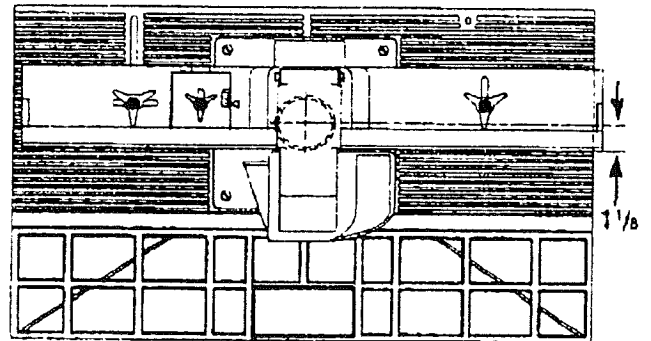

FIGURE 11.

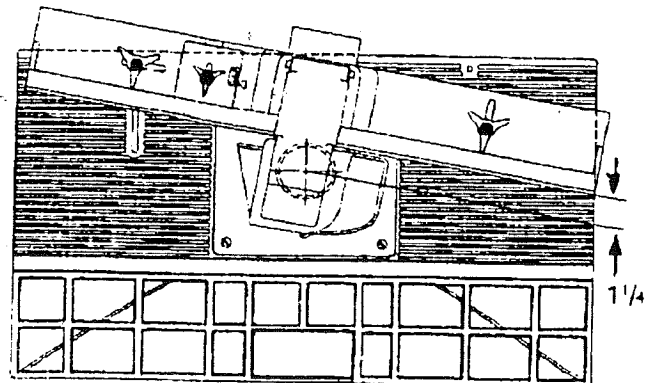

FIGURE 12.

For all routing operations away from edge on the underside of workpiece, such as Grooving, Fluting, Veining, Crown Molding, etc., attach fence using back hole and the slot. See Figures 13 and 14 for available fence adjustment from the router bit center.

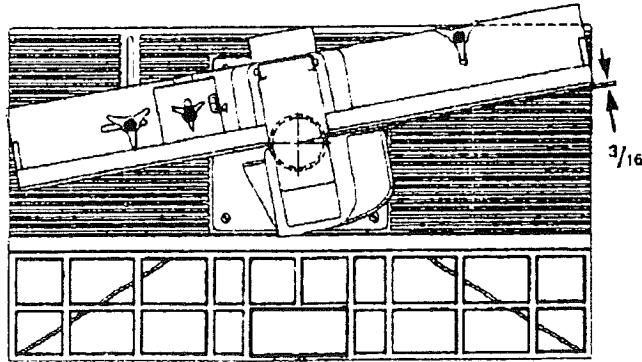

FIGURE 13.

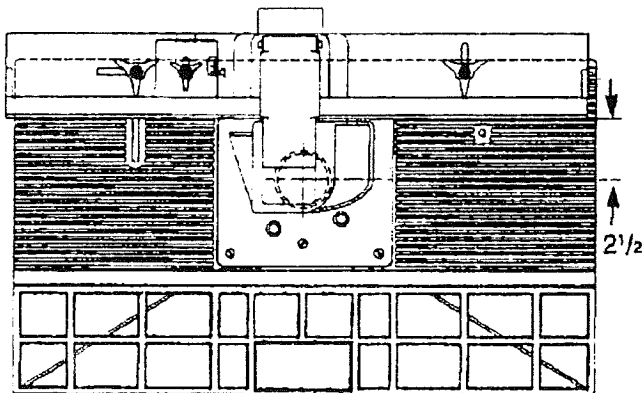

FIGURE 14.

1. Assemble unitized fence assembly to table as shown in Figure 15.

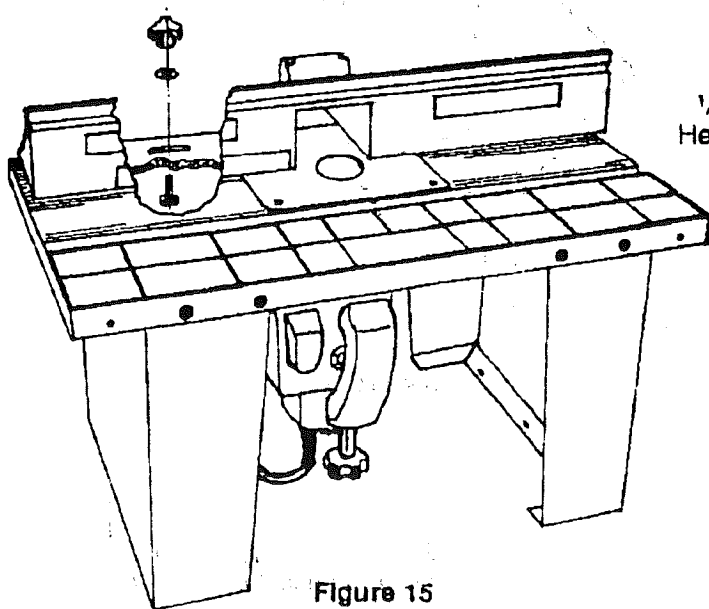

Figure 15

2. Depending upon the routing operation, insert one of the 1/2-20 x 1 3/4" long carriage bolts through one of the holes on the right side of the of the table top (from the underside) and the short slot in the fence. Make sure square of bolt fits into square recess in table.
3. While holding the bolt in place, install a 5/32" I.D. flat washer and a large 1/4-20 knob onto the bolt to loosely secure the fence to the table.
4. Repeat Steps 2 and 3 for table slot and fence slot on the left side of the table.

ASSEMBLY OF PUSH BLOCK

1. Screw the small end of clamp rod into threaded hole in clamp plate until the plate bottoms on it's shoulder (make sure clamp is oriented such that letter "C" is facing outwards as shown in Figure 16).
2. Tightly secure clamp plate to clamp rod using 1/4" helical lock washer and a hex nut.
3. Insert the opposite threaded end of clamp rod through hole in push block and install a flat washer and a wing nut onto it. (Refer to Figure 18.)

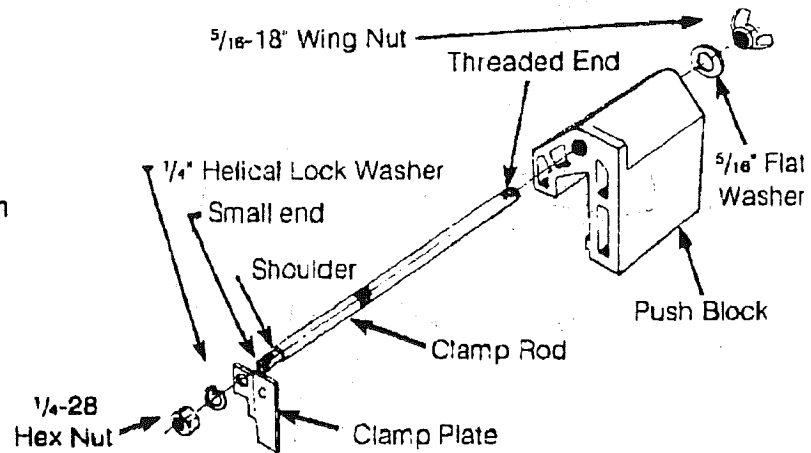

FIGURE 16.

WARNING: ROUTER VIBRATIONS SOMETIMES CAN CAUSE 1/4-28 HEX NUT AND CLAMP PLATE TO GET LOOSE! PERIODICALLY CHECK FASTENERS AND CLAMP PLATE TO MAKE SURE THEY ARE TIGHT AND SECURE.

MOUNTING PUSH BLOCK ASSEMBLY ON UNITIZED FENCE

Clamp plate when free, tries to swing in the direction of arrow due to it's weight. (See Figure 17.)

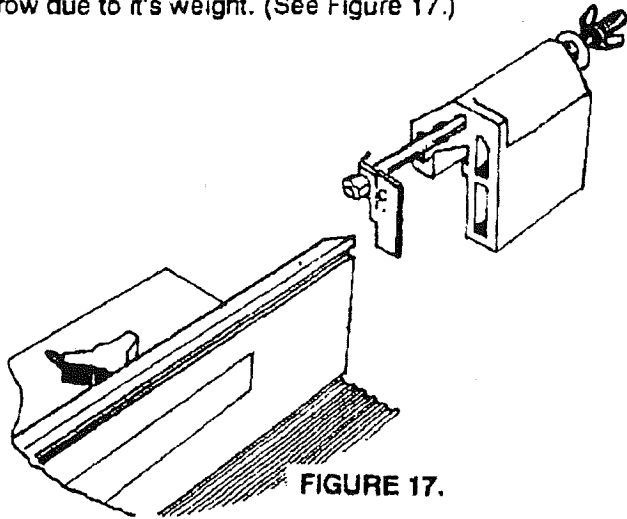

FIGURE 17.

1. Mount push block assembly on the unitized fence by supporting clamp plate against the face of the fence (Figure 18.) and aligning retaining rib on push block with the groove in the face of unitized fence. (See Figures 17 and 18.)
2. Slide push block assembly back and forth along entire length of unitized fence to see that it slides freely.

NOTE: a. Remove dust and chips from sliding surfaces of push block and unitized fence as needed to maintain good sliding motion.

- b. Occasional application of furniture spray wax on the sliding surfaces ONLY of the PUSH BLOCK will greatly improve the sliding motion.

FOR ROUTING ON ENDS (TENONS, SLIDING DOVE-TAILS, ETC.) THE WORKPIECE IS HELD AGAINST FACE OF UNITIZED FENCE AND CLAMPED BETWEEN CLAMP PLATE AND SURFACE "S" OF PUSH BLOCK. (SEE FIGURE 18.)

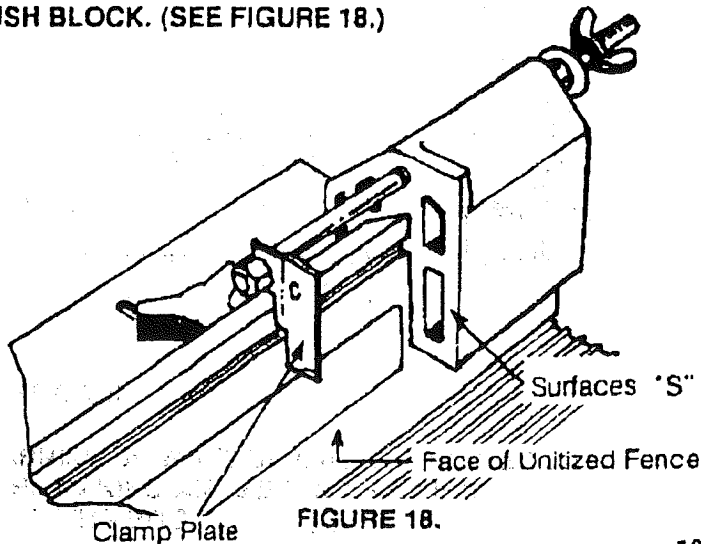

FIGURE 18.

ASSEMBLY GUARD TO UNITIZED FENCE

1. Assemble guard to unitized fence as shown in Figure 19.
2. Press one of the $\frac{1}{4}$ " push nuts onto one end of the $\frac{1}{4}$ " Diameter x $2\frac{11}{16}$ " long pivot pin. (It may be necessary to tap it onto pin with a hammer).
3. Position the guard on the fence so the holes in the guard line up with the hole in fence.
4. Insert pivot pin through holes.
5. Press remaining $\frac{1}{4}$ " push nut onto the other end of the pivot pin.

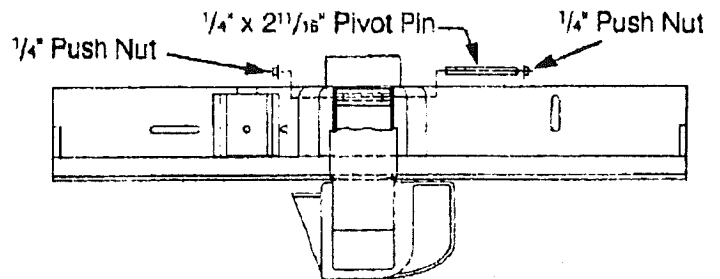

FIGURE 19.

6. Pivot guard back and forth a few times to make sure that it moves freely.

NOTE: Once the guard has been installed, do not remove it for any reason.

DUST COLLECTING ATTACHMENT

Unitized fence is provided with a hookup for most Sears Craftsman $2\frac{1}{2}$ " hose diameter vacs.

Attach $2\frac{1}{2}$ " hose nozzle as shown in Figure 20.

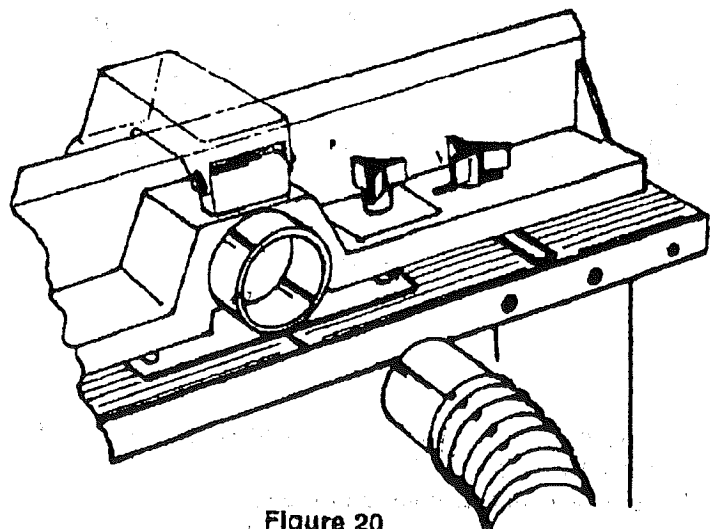

Figure 20

NOTE: OPERATING ROUTER TABLE WITHOUT USE OF WET/DRY VAC MAY RESULT IN EXCESSIVE COLLECTION OF SAWDUST AND CHIPS UNDER THE FENCE AND THE GUARD.

REMOVE DUST AND CHIPS FROM UNDER THE GUARD AND THE FENCE AS NEEDED TO MAINTAIN GUARD AND FENCE FUNCTION. MAKE SURE THE ROUTER IS TURNED OFF AND THE BIT IS NOT ROTATING WHEN DOING THIS. KEEP WORK AREA CLEAN.

MOUNTING THE ROUTER TABLE

THE ROUTER TABLE MUST ALWAYS BE FIRMLY AND SECURELY MOUNTED TO A WORK SURFACE BEFORE USE. FAILURE TO DO SO COULD CAUSE TABLE TO TIP OVER OR SLIDE RESULTING IN PROPERTY DAMAGE AND/OR SERIOUS PERSONAL INJURY.

A. TO A WORK SURFACE

Each leg has three slotted holes at the bottom for mounting. Firmly secure router table to work surface, using appropriate fasteners (not provided) as shown in Figure 21. The slots are $\frac{1}{4}$ " wide x $\frac{5}{8}$ " long and will accommodate screw sizes up to #12.

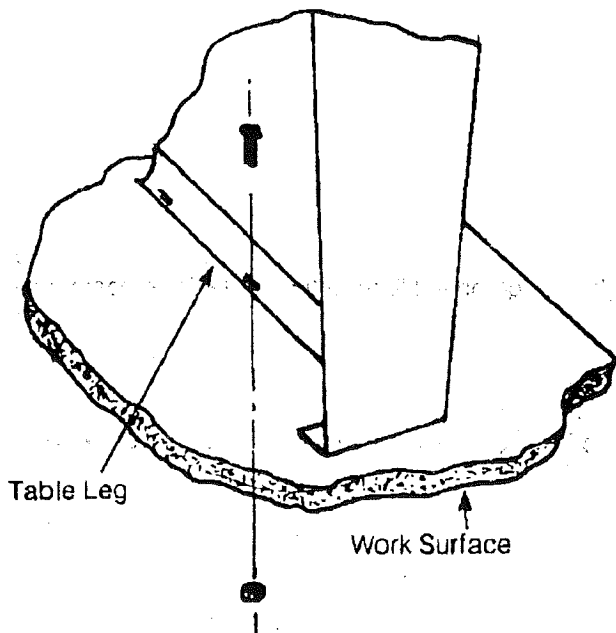

FIGURE 21.

For added versatility, secure the table to a piece of $\frac{1}{2}$ " or thicker plywood which can be "C" clamped to your work surface:

B. TO SEARS LEG SET #22235

Assemble leg set as directed by the instructions included with the leg set.

1. Place the router table on the assembled leg set with the router table base flush with the front of the leg set. The holes in the base of the router table should align with holes in the leg set as shown in figure 22.
2. Secure the router table with hardware provided in the leg set.

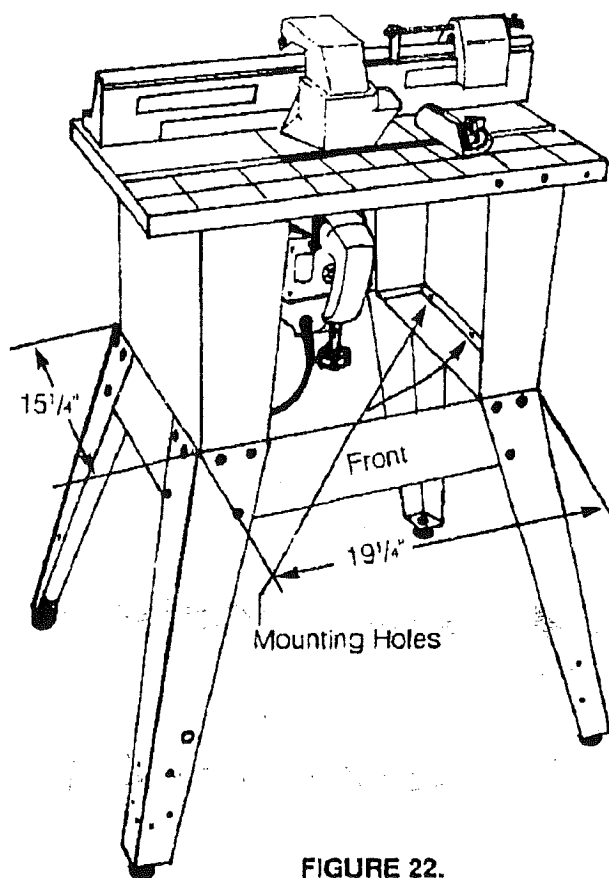

FIGURE 22.

ASSEMBLY OF MITER GAUGE

Assemble protractor head to miter bar as shown in Figure 23.

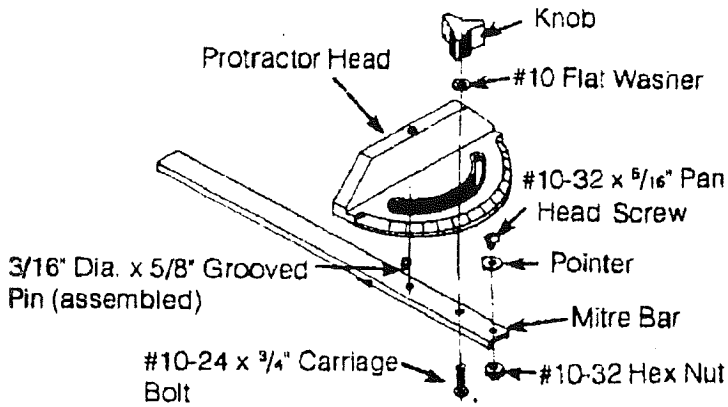

FIGURE 23.

ALIGNMENT OF UNITIZED FENCE TO MITER BAR SLOT

1. Measure distance from each end of unitized fence to edge "E" of miter bar slot on the table as shown in Figure 24. If both distances are the same, the fence is parallel to miter bar slot. If not, loosen large knobs and adjust fence accordingly. Tighten both knobs.
2. Position miter gauge on table as shown in Figure 24.

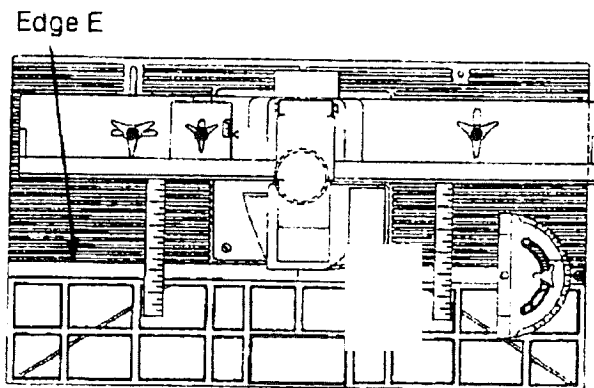

FIGURE 24.

OPERATION

WARNING: ALWAYS UNPLUG THE ROUTER BEFORE MAKING ANY SETTING, ADJUSTMENTS, OR CHANGING BITS.

The unitized fence on your table is provided as a guide against which the workpiece should be held for accuracy in routing. Free hand routing (not holding work against the fence) is hazardous and should be strictly avoided without piloted router bits.

ADJUSTING DEPTH AND HEIGHT OF CUT

Rotate the guard upward in order to have full access to the router bit for making adjustments; select a board that is smooth with its edges true to each other and its surfaces and:

1. Mark lines "A" and "B" on the end of this board. Line "A" for desired depth of cut (amount of material you want to remove) and line "B" for desired cutting height. See Figure 25.
2. Clamp this board against the face of the fence with edge resting on table top and end marked with lines "A" and "B" close to the bit. See Figure 25. (MAKE SURE ROUTER IS UNPLUGGED WHEN CLAMPING BOARD AND MAKING ADJUSTMENTS).

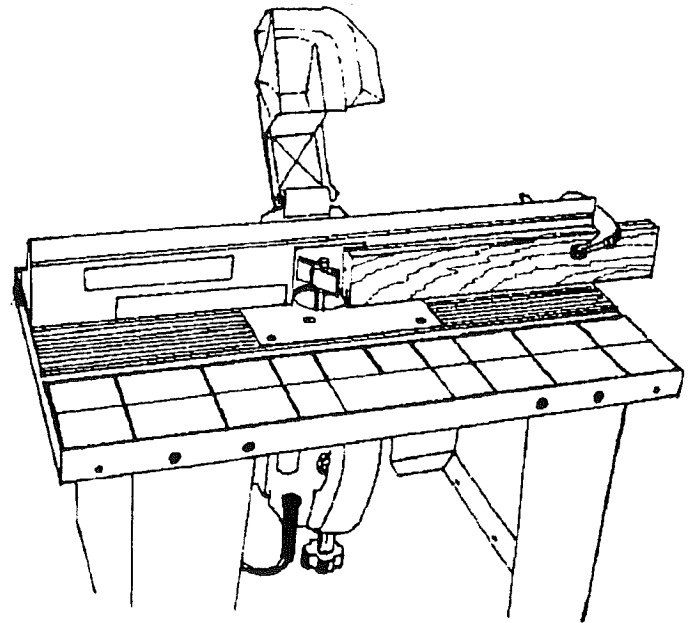

FIGURE 25.

3. Loosen both large knobs that allow movement of fence and move forward and backward until outermost cutting edge of router bit is aligned with line "A". Tighten both knobs.

4. Raise or lower the router until top edge of bit is aligned with line "B". (Refer to your router's owner's manual for adjusting your router properly).

AFTER MAKING THIS ADJUSTMENT, BE SURE ROUTER IS SECURELY TIGHTENED IN THE ROUTER BASE, THE BIT IS SECURELY TIGHTENED IN THE ROUTER CHUCK, AND ROUTER BASE IS TIGHTLY SECURED TO TABLE TOP.

5. Remove the board from the fence and lower the guard to operating position.

WARNING: DO NOT OPERATE ROUTER IF ANY PART OF THE BIT CONTACTS THE GUARD.

NOTE: Workpiece to be routed could be substituted for with scrap board when making adjustment.

USING ROUTER TABLE AS JOINTER (FULL EDGE CUTTING)

For maximum strength and accuracy, boards to be jointed together should be smooth and true. The edges should be true to the workpiece surface. You can true the edges on your router table using a straight bit.

1. Check to see if face of jointing fence is flush with the face of unitized fence. If not, loosen small knob on jointing fence and adjust. Tighten knob on jointing fence.

NOTE: The jointing fence provides a continuous support for the workpiece, as it is fed beyond the router bit. It compensates for the gap created by the removal of material by the router bit.

2. Adjust depth of cut (material you want to remove) and router bit height as described previously for Figure 25. Tightly secure the fence and the router as described before. (MAKE SURE ROUTER IS UNPLUGGED WHEN MAKING ADJUSTMENTS).

3. Lower guard to operating position.

4. Check your adjustments by turning the router "ON" and feeding a piece of scrap wood a few inches beyond router bit. Then stop and turn router "OFF"

NOTE: Feed work against the rotation of the cutter (in the direction shown by arrow in Figure 26).

5. Loosen knob on jointing fence and move it out, flush against the finished edge of scrap wood. Retighten the knob. See Figure 26.

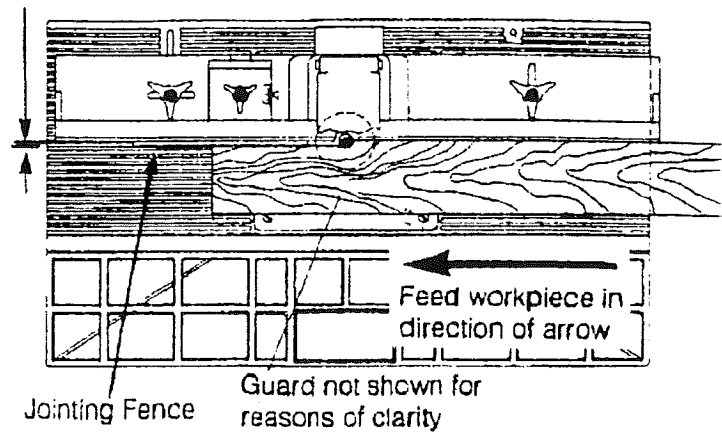

FIGURE 26.

6. Repeat the test cut on the scrap wood with guard down.

7. The router table is now ready for use.

NOTE: For best jointing results, take very shallow cuts: $1/32$ " or less.

USING ROUTER TABLE FOR EDGE CUTTING—

with non-piloted bits:

1. Position the jointing fence such that its face is flush with the face of unitized fence. Tighten small knob on jointing fence. See Figure 27.

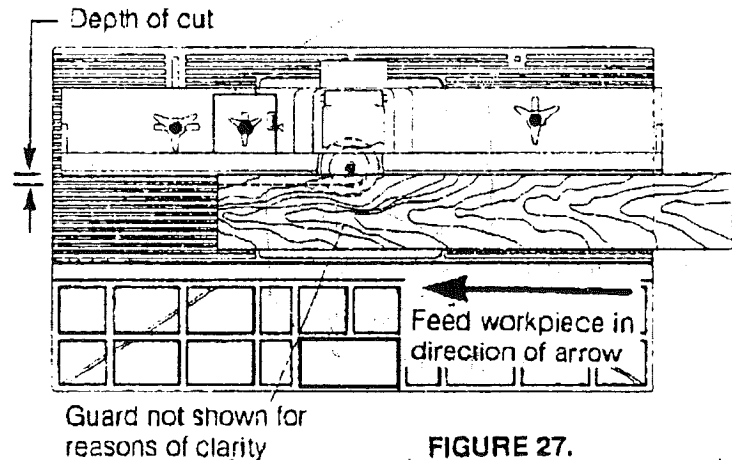

FIGURE 27.

2. Adjust depth of cut (material you want to remove) and router bit height as described before. Tighten both large knobs to lock fence on table. Tightly secure the router. (MAKE SURE ROUTER IS UNPLUGGED WHEN MAKING ADJUSTMENTS).

3. Lower guard to operating position.

4. Test cut a piece of scrap wood to make sure adjustments are satisfactory.

NOTE: Feed work against the rotation of the cutter (in the direction shown by the arrow in Figure 27).

5. The router table is now ready for use.

with piloted bits:

When bits with pilots are used to control the cutting depth:

1. Position the jointing fence in the same manner as with non-piloted bits.
2. Move the unitized fence back only enough to permit the pilot to control the cutting depth. Positioning the unitized fence as close to the pilot as possible will serve as a backup and will help to prevent chances of an accident, and possible personal injury, See Figure 28.

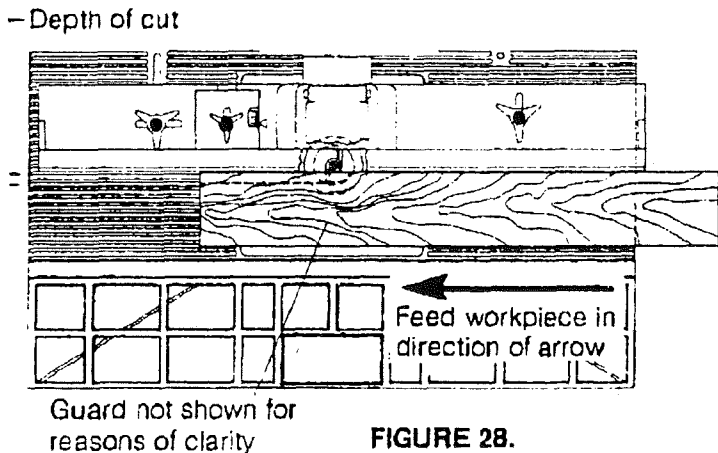

FIGURE 28.

3. Lower guard to operating position.

USING ROUTER TABLE FOR END CUTTING

WARNING: END CUTTING IS PERFORMED WITH THE GUARD ROTATED BACK SO THAT IT DOES NOT COVER THE BIT. THEREFORE, EXTREME CARE MUST BE TAKEN WHEN END CUTTING, SO THAT YOUR FINGERS, HANDS, OR ANY OTHER PART OF YOUR BODY DOES NOT CONTACT THE BIT WHICH CAN RESULT IN SERIOUS BODILY INJURY.

When routing on ends of workpiece for making tenons, sliding dovetails and tongue and groove joints, the workpiece must be made smooth with both edges and ends made true to each other and its surfaces.

NOTE: The push block and clamp plate assembly will not accommodate workpieces wider than 4".

EXAMPLE: CUTTING TENONS

1. Make certain that jointing fence is locked in position with its face flush with that of unitized fence.
2. Mount push block assembly on unitized fence as shown before in Figures 17 and 18.
3. Install proper table insert into the throat plate hole.
4. Mark lines "A" and "B" on the edge of the workpiece close to the end to be cut. Line "A" for FULL DEPTH OF CUT (total amount of material you want to remove) and line "B" for FULL DESIRED HEIGHT OF TENON. See Figure 29

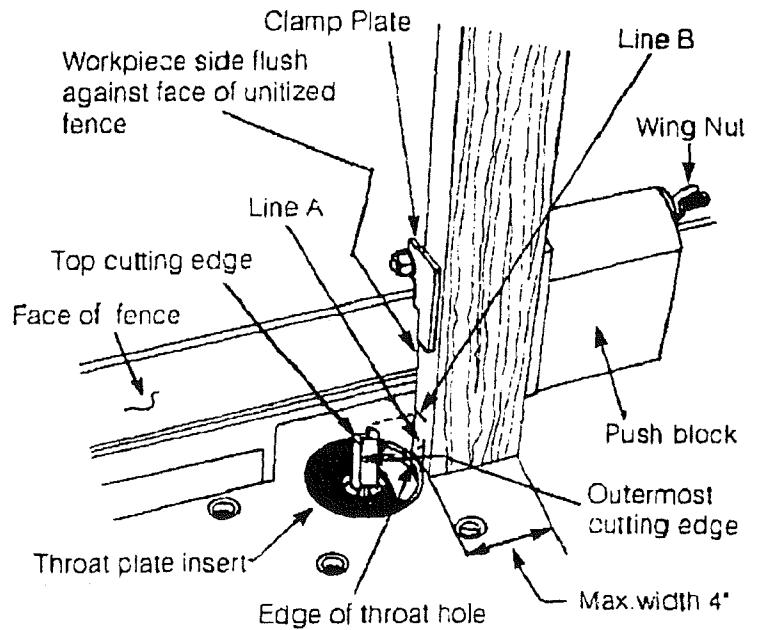

FIGURE 29.

5. Position workpiece between clamp plate and push block so that its side is held flush against face of the unitized fence, the end to be cut is resting on the edge of the throat plate hole and edge marked with lines "A" and "B" is facing router bit. Clamp workpiece in this position by snugly tightening the wing nut on clamp rod while making sure that clamp plate stays oriented on workpiece, as shown in Figure 29. MAKE SURE ROUTER IS UNPLUGGED WHEN POSITIONING AND CLAMPING WORKPIECE AND MAKING ADJUSTMENTS.

NOTE: Tighten wing nut just enough to clamp workpiece in position. OVERTIGHTENING wing nut could cause binding in the sliding motion of push block, which in turn may result in variations and/or steps in the finished tenon surface when cut. See Figure 32.

6. Slide workpiece close to the bit and adjust unitized fence and the router as described before so that outer most cutting edge of bit is aligned with line "A" and top cutting edge of bit is aligned with line "B". See Figure 29. Tightly secure the fence and the router as described before in ADJUSTING DEPTH AND HEIGHT OF CUT.

7. Slide push block and therefore workpiece back to the position as shown in Figure 30.

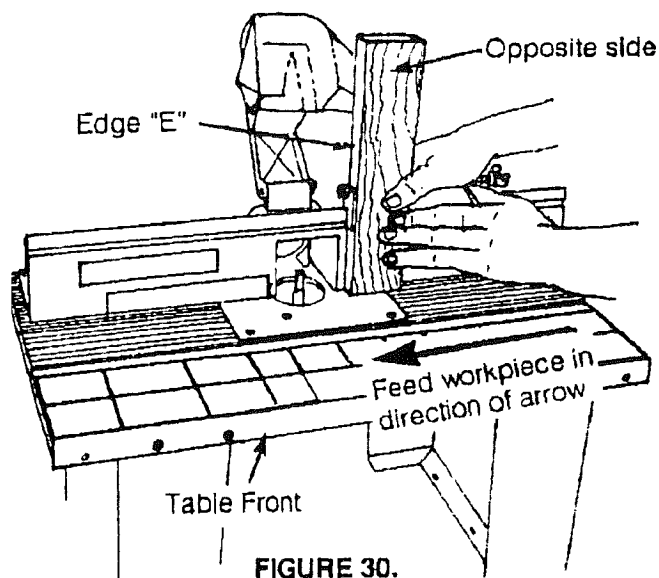

FIGURE 30.

WHEN ROUTING, ALWAYS FEED AGAINST THE ROTATION OF THE CUTTER. FEED WORKPIECE IN THE DIRECTION SHOWN BY THE ARROW. SEE FIGURE 24.

8. Turn router and shop vac "ON". While holding push block and GUIDING WORKPIECE AGAINST FENCE with both hands and FINGERS (Figure 30) AT A SAFE DISTANCE FROM SPINNING BIT, feed the workpiece across the bit to make FULL DEPTH OF CUT IN ONE PASS. (DO NOT STOP FEEDING UNTIL WORKPIECE IS FAR ENOUGH PAST SPINNING BIT).

NOTE: Clamp and test cut a piece of scrap wood to check your adjustments before making your finished cut.

9. Turn router and shop vac "OFF". Unclamp work piece, and slide push block back.

10. Position and clamp the opposite side of workpiece in the same manner as described in Step 5 (make sure the wing nut is tight just enough to clamp workpiece in position and end to be cut is resting on the edge of throat plate hole). Repeat steps 7, 8, and 9.

in the same manner as in step 5 above, except edge of workpiece should be held flush against face of fence and end to be cut should be resting on edge of throat plate hole. See Figure 31. Repeat steps 7, 8, 9, and 10.

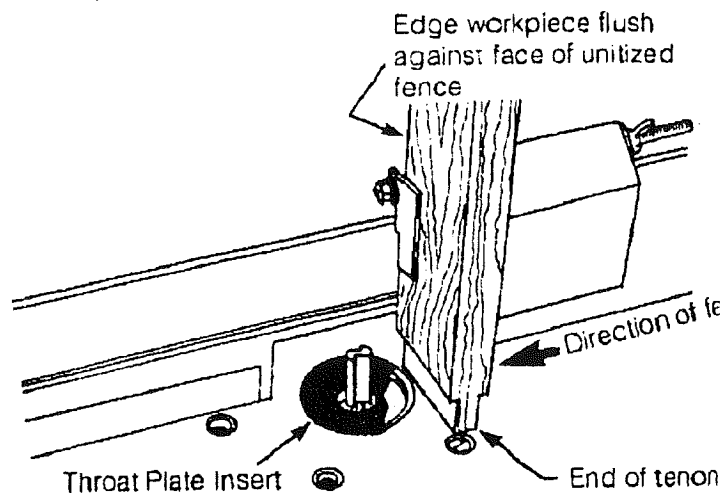

FIGURE 31.

NOTE: When cutting tenons, always clamp workpiece with end to be cut resting on edge of throat plate hole. This will minimize steps in finished tenon surface due to variations in the table top flatness. (Refer to Figure 32.)

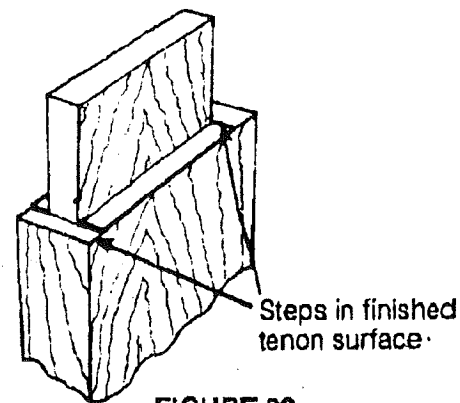

FIGURE 32

NOTE: Always cut full depth on all four sides of tenon in one pass across the bit.

USING ROUTER TABLE FOR OPERATIONS AWAY FROM EDGE ON THE UNDERSIDE OF WORKPIECE SUCH AS GROOVING, FLUTING, VEINING, ETC.

ALWAYS UNPLUG THE ROUTER BEFORE MAKING ANY SETTING, ADJUSTMENTS, OR CHANGING BITS

WHEN ROUTING, ALWAYS FEED AGAINST THE ROTATION OF THE CUTTER. FEED WORKPIECE IN THE DIRECTION OF ARROW IN FIGURE 34.

For maximum accuracy, one edge of your workpiece (edge sliding against the fence) must be true and straight. Set up your fence as follows:

1. Raise guard and rest it against the back of the vacuum outlet.
2. Position the fence behind the router bit for the desired cutting depth (the distance of the cut from the edge of the workpiece, as shown in Figure 33).

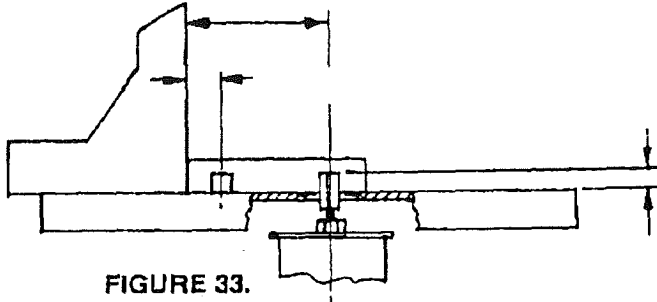

FIGURE 33.

3. Securely tighten both knobs and LOWER THE GUARD OVER THE BIT.
4. Make the cut by sliding straight edge of workpiece against the fence. Use a push stick as shown in Figure 34. (For each successive cut, the fence would need to be re-adjusted).

NOTE: Test cut a piece of scrap wood before making your finish cut. Feed workpiece in the direction of arrow (Refer to Figure 34).

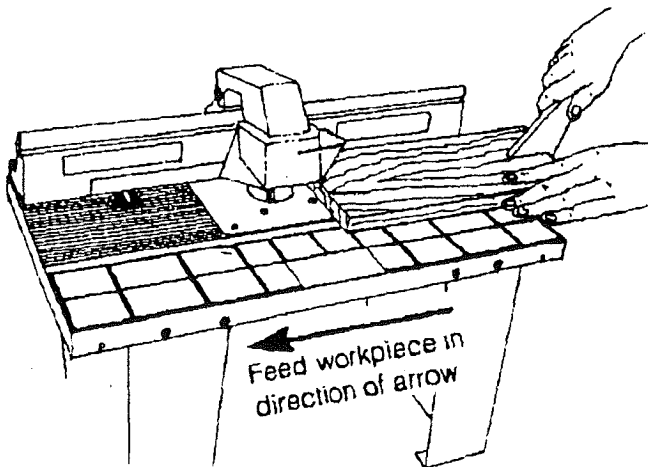

FIGURE 34

NOTE: When routing deep cuts (controlled by router bit) in a workpiece, remove material in increments to prevent your router from overloading. Repeat operation with several passes until the desired depth is achieved.

USING ROUTER TABLE WITHOUT THE UNITIZED FENCE

WARNING: ROUTING WITHOUT THE UNITIZED FENCE AND THUS THE GUARD COULD CAUSE ACCIDENTS AND POSSIBLE PERSONAL INJURY. EXTREME CARE MUST BE TAKEN FOR THIS ROUTING OPERATION.

ALWAYS UNPLUG THE ROUTER BEFORE MAKING ANY SETTING ADJUSTMENTS, OR CHANGING BITS.

ALWAYS FEED WORKPIECE AGAINST THE ROTATION OF THE CUTTER.

ONLY PILOTED ROUTER BITS ARE TO BE USED.

MANY ROUTING APPLICATIONS (SUCH AS SHOWN IN FIGURE 35) WILL REQUIRE THE FENCE TO BE REMOVED FROM THE TABLE.

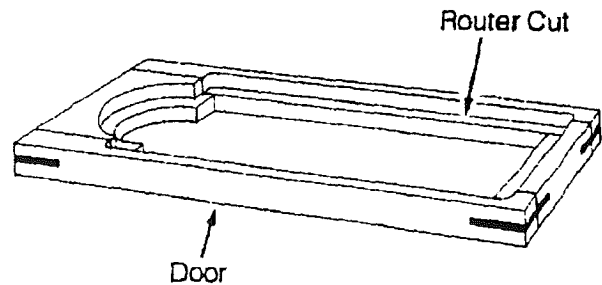

FIGURE 35

If the workpiece being cut is between the cutter and the operator, then feed from RIGHT TO LEFT as shown in Figure 36.

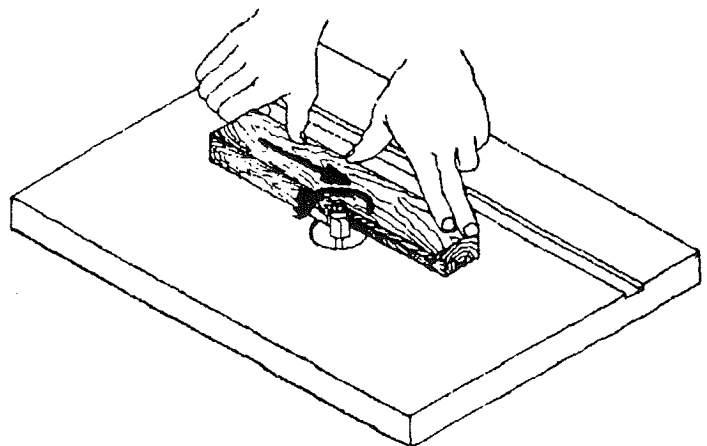

FIGURE 36

If the cutter is between the operator and the workpiece being cut, then feed from LEFT TO RIGHT as shown in Figure 37.

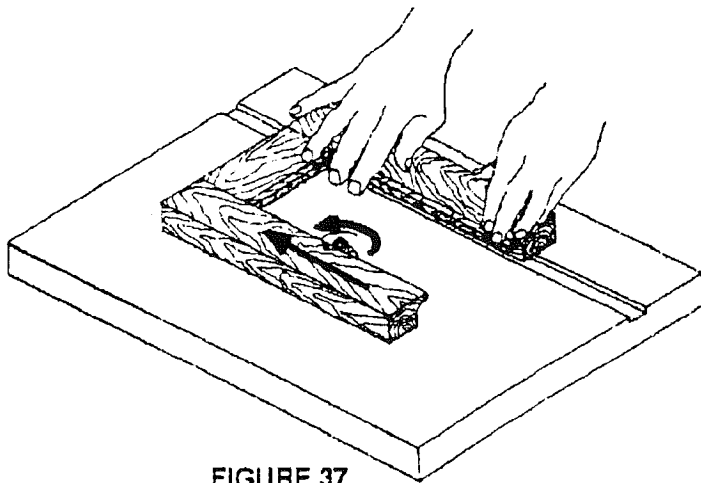

FIGURE 37

FREE ROUTING IRREGULARLY SHAPED WORK PIECES

For routing irregularly shaped work pieces, a starting pin is provided. The starting pin is used for "free-routing" with piloted bits only. It is not used for any other operation described in this manual.

1. Remove the fence from the table.
2. Thread starting pin into tapped hole in the throat plate, as shown in Figure 38, and tighten securely.
3. To free route with starting pin, orient workpiece on table top against starting pin, as shown by position #1 in Figure 38. Workpiece should not contact cutter.
4. Gradually swing workpiece contacting pilot, swing workpiece against the cutter until the complete edge of the work piece has been cut. Then slide workpiece away from cutter.

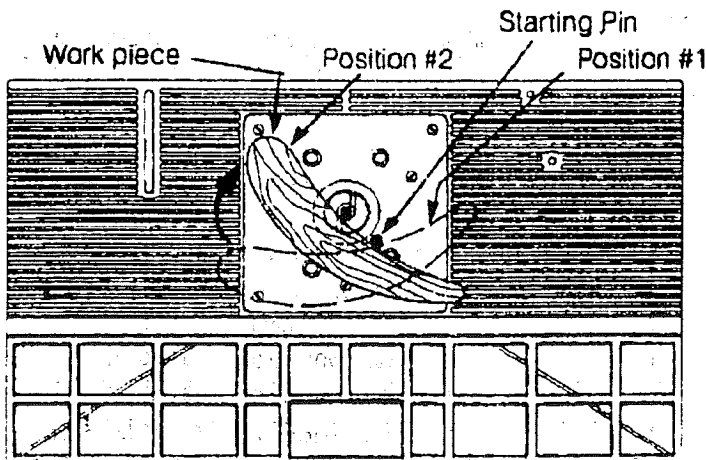

FIGURE 38

5. With this workpiece contacting pilot, swing workpiece away from the starting pin, as shown by position #3 in Figure 39.

6. At this point, the piloted router bit is acting as a guide and not the starting pin. Feed the workpiece against the rotation of cutter until the complete edge of the workpiece has been cut. Then slide workpiece away from cutter.

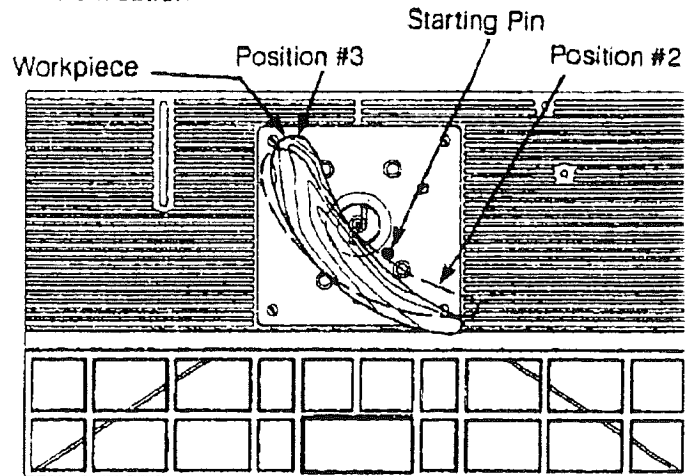

FIGURE 39

PROTRACTOR

Your protractor will serve as a handy aid when extra support is needed for routing small workpieces or ends of large workpieces. See Figure 40.

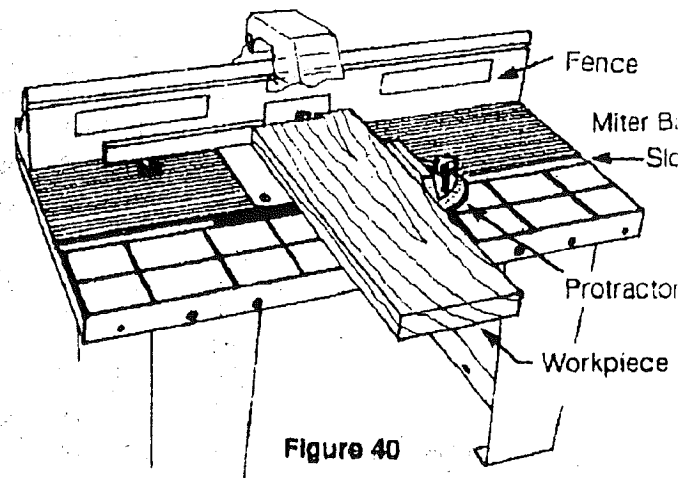
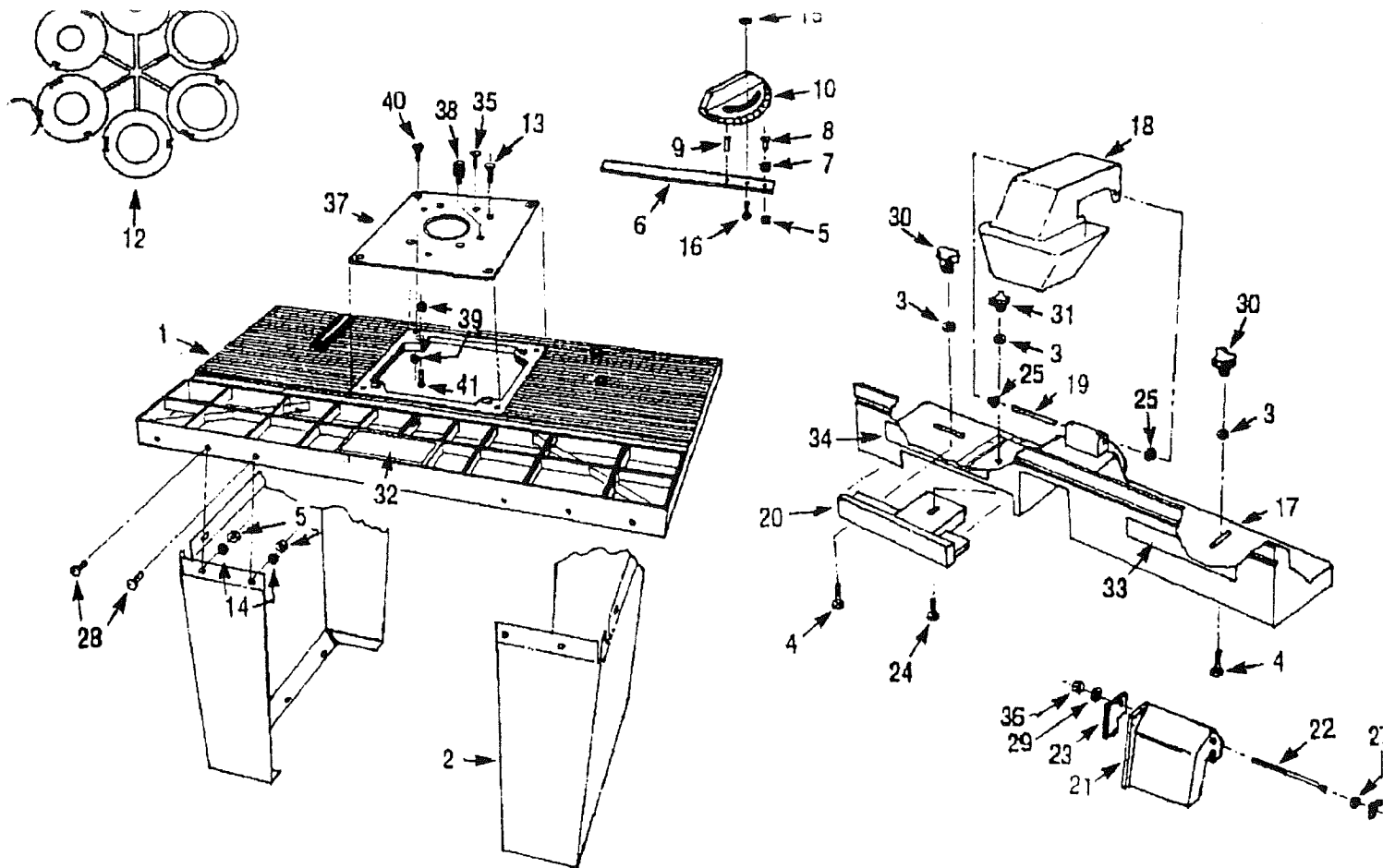

Figure 40

NOTE: FOR ALL ROUTING OPERATIONS REQUIRING USE OF MITER GAUGE ALONG WITH THE FENCE, BE SURE TO ALIGN FENCE WITH MITER BAR SLOT BEFORE MAKING ANY CUTS. SEE FIGURE 24.

Notes



Key No.	Part No.	Description	Quan.	Key No.	Part No.	Description	Quan.
1	29LCN-753	Router Table	1	22	29L-651	Clamp Rod	1
2	29LCN-755	Table Leg	2	23	29L-652	Clamp Plate	1
3	29A-306-14	3/40D x 9/32ID Washer	3	24	29A-246-12	1/4-20 x 1 lg Hex Head Cap Screw	1
4	29A-310-7	1/4-20 x 1-3/4 lg Carnage Bolt	2	25	29GD-321	1/4 Washer Cap Push Nut	2
5	29A-242-12	#10-32 Hex Machine Screw Nut	13	26	29A-252-8	5/16-18 Wing Nut	1
6	31L-559	Miter Bar	1	27	29A-306-27	11/160D x 11/32ID Washer	1
7	31L-438	Pointer	1	28	29LCN-763	#10-32 x 5/8 lg Smooth Truss Head Screw	12
8	29A-264-8	#10-32 x 5/16 lg Panhead Screw	1	29	29A-327-3	1/4 Helical Lockwasher	1
9	29L-183	3/160D x 5/8 lg Groove Pin	1	30	29L-660	Knob	2
10	29L-293	Protractor Head	1	31	29L-659	Knob	1
11	31L-560	Knob	1	32	45A-322	Label (Router Table)	1
12	29LCN-761	Plastic Insart Washer	6	33	45A-323	Warning Label (Fence)	1
13	29A-298-13	#10-32 x 3/8 lg Flathead Screw	3	34	45A-324	Label (Fence)	1
14	29A-509-1	#10 Lock Washer	12	35	29LCN-762	M8 X 25 (Metric) Flat C'Sunk HD Screw	8 x 1.25
15	29A-306-15	1/20D x 3/16ID Washer	1	36	29A-242-8	1/4-28 Hex Machine Screw Nut	1
16	29A-310-5	#10-24 x 3/4 lg Carnage Bolt	1	37	29LCN-756	Throat Plate	1
17	29LCN-754	Fence	1	38	29P-84-13	Starting Pin (7/16" Pilot)	1
18	29LCN-760	Guard (Overhead)	1	39	29LD-123-2	#10-32 Hex Stop Nut (ESNA)	8
19	29LCN-757	Overhead Guard Pivot Pin	1	40	29A-298-1	#10-32 x 5/8 lg Flathead Screw	4
20	29LCN-758	Adjustable Fence	1	41	29A-264-7	#10-32 x 5/8 Panhead Screw	4
21	29LCN-759	Push Block	1	42	49LCN-39	Instruction Manual	1