



SNAPPER PRO

OPERATOR'S MANUAL

with Setup Instructions

FAST-Vac Grass Collection Systems

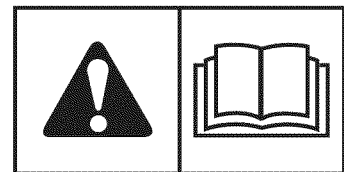

IMPORTANT NOTE:

These FAST-Vac Systems fit 2005 and newer Model Year product equipped with the rubber discharge chute.

NHSystem Number:	Description:
5600001	IS500Z, & IS1500Z, 44" Mower Deck - 2 Bag System
5600002	IS1500Z & S150X, 48" Mower Deck - 2 Bag System
5600003	IS1500Z & S150X, 48" Mower Deck - 3 Bag System
5600004	IS1500Z & S150X, 52" Mower Deck - 3 Bag System (S/N: 2012628762 & Below)
5600005	IS3000ZL, 61" Mower Deck - 3 Bag System
5600006	IS3000Z & IS3000ZX, 61" Mower Deck - 3 Bag System (S\N 3631 & Above)
5600007	IS1000Z, 52" Mower Deck - 3 Bag System (S\N 2531 & Above)
5600008	IS1000Z, 61" Mower Deck - 3 Bag System (S\N 2899 & Above)
5600009	IS4500Z, 61" Mower Deck - 3 Bag System
5600057	IS2000Z & S200X, 61" Mower Deck - 3 Bag System
5600060	IS3100Z, 61" Mower Deck - 3 Bag System
5600061	IS2000Z, 52" Mower Deck - 3 Bag System (S/N: 2012628762 & Below)
5600083	IS3100ZBS, 61" Mower Deck - 3 Bag System
5600148	IS1500Z & S150X, 52" Mower Deck - 3 Bag System (S/N: 2012628763 & Above)
5600150	IS2000Z, 52" Mower Deck - 3 Bag System (S/N: 2012628763 & Above)

5100063

Revision K

Rev. Date: 10/2007

TP 100-7219-K-AT-UV

Thank you for purchasing this quality-built Ferris product. We're pleased that you've placed your confidence in the Ferris brand. When operated and maintained according to the instructions in this manual, your Ferris product will provide many years of dependable service.

This manual contains safety information to make you aware of the hazards and risks associated with this machine and how to avoid them. This machine is designed and intended to be used and maintained according to the manual for finish cutting of established lawns and is not intended for any other purpose. It is important that you read and understand these instructions thoroughly before attempting to start or operate this equipment.

DATE PURCHASED / FECHA COMPRADA

--	--	--	--	--	--

Briggs & Stratton Yard Power Products Group
Copyright © 2007 Briggs & Stratton Corporation
Milwaukee, WI, USA. All rights reserved.

The Ferris logo is a trademark of Briggs & Stratton Corporation Milwaukee, WI, USA.

Contact Information:

Briggs & Stratton Yard Power Products Group
5375 N. Main St.
Munnsville, NY 13409-4003
(800) 933-6175
www.ferrisindustries.com

Table of Contents

SAFETY RULES & INFORMATION	2
Safety Decals.....	3
GENERAL OPERATING INSTRUCTIONS.....	4
Before Operation.....	4
Mowing with the Double / Triple Catcher	4
After Operation.....	5
Storing the Grass Catcher	5
Mowing Without the Blower	5
INSTALLATION.....	6
Suspension Adjustment	6
Ball Joint Replacement	7
Blower Assembly.....	8
Mower Deck Preparation	12
Blower Installation.....	17
Collector Installation.....	19
Weight Mount Installation	
1000Z Series	27
Weight Mount Installation	
IS1000Z Series.....	28
Weight Mount Installation	
IS3000Z Series & IS3100Z Series	29
Weight Mount Installation	
IS500Z & IS1500Z Series	30
Weight Mount Installation	
IS2000Z Series.....	31
Weight Mount Installation	
IS4500Z Series.....	32
Weight Mount Installation	
S150X & S200X Series	33
BLOWER & COLLECTOR REMOVAL	34

REGLAS E INFORMACIÓN DE SEGURIDAD...36	
Calcomanías de seguridad	36
INSTRUCCIONES GENERALES	
DE OPERACIÓN.....	37
Antes de la operación	37
Podar con el receptor doble o triple.....	37
Después de la operación	38
Almacenar el receptor de pasto.....	38
Podar sin el soplador	39
REMOCIÓN DEL SOPLADOR Y RECEPTOR...39	



Read these safety rules and follow them closely. Failure to obey these rules could result in loss of control of unit, severe personal injury or death to you, or bystanders, or damage to property or equipment. **This mowing deck is capable of amputating hands and feet and throwing objects.** The triangle  in text signifies important cautions or warnings which must be followed.

GENERAL WARNINGS

- Know the mower controls, safety rules and how to stop quickly. **READ AND UNDERSTAND THE MOWER OPERATOR'S MANUAL.**
- Read and obey all safety decals.
- Wear appropriate ear, eye and breathing protection.
- Only allow responsible adults, who are familiar with the instructions, to operate the unit.
- Disengage the electric clutch (PTO). Shut off the engine and wait for all moving parts to stop before attaching, adjusting, or disconnecting any part of the collection system.
- Check the collection system to make sure it is bolted tightly to the rider.
- **DO NOT** operate the mower without either the entire grass catcher or the deflector in place.
- Turn off the PTO switch to disengage the blades when not mowing.
- **DO NOT** mow in reverse. Always look down and behind before and while travelling in reverse.
- **DO NOT** turn sharply when travelling alongside a building or any object. Slow down before turning.
- **DO NOT** carry passengers on the rider.
- When blower assembly is removed from the mower deck, the deflector must be properly installed.
- Collector bags are subject to deterioration and wear during normal use. Inspect the bag periodically for tears, holes or weak spots and replace with a new bag that meets manufacturer's durability standards.
- If the mower stalls or the turbo blower chute plugs:
 1. Disengage the electric clutch (PTO);
 2. Stop the engine and remove the key;
 3. Set the parking brake, and wait for all moving parts to stop.
 4. Remove the foreign object or clear the chute with a piece of wood before restarting the engine. **NEVER place hands into blower housing to clear jammed object. Blower may rotate when object is removed.**
- For added rider stability and to prevent tipping or loss of control:
 - a. Use reduced speed on uneven ground and when turning corners.
 - b. Reduce loads on hillsides. It is recommended that the collection system be kept no more than half full when negotiating any slopes. Start mowing on slopes when the collection system is empty.
 - c. Mow across the face of slopes; not up and down.
- **Never operate on slopes greater than 17.6% (10°).**

SAFETY DECALS

This unit has been designed and manufactured to provide you with the safety and reliability you would expect from an industry leader in outdoor power equipment manufacturing.

Although reading this manual and the safety instructions it contains will provide you with the necessary basic knowledge to operate this equipment safely and effectively, we have placed several safety labels on the unit to remind you of this important information while you are operating your unit.

All DANGER, WARNING, CAUTION and instructional messages on your rider and mower should be carefully read and obeyed. Personal bodily injury can result when these instructions are not followed. The information is for your safety and it is important! The safety decals below are on your rider and mower.

If any of these decals are lost or damaged, replace them at once. See your local dealer for replacements.

These labels are easily applied and will act as a constant visual reminder to you, and others who may use the equipment, to follow the safety instructions necessary for safe, effective operation.

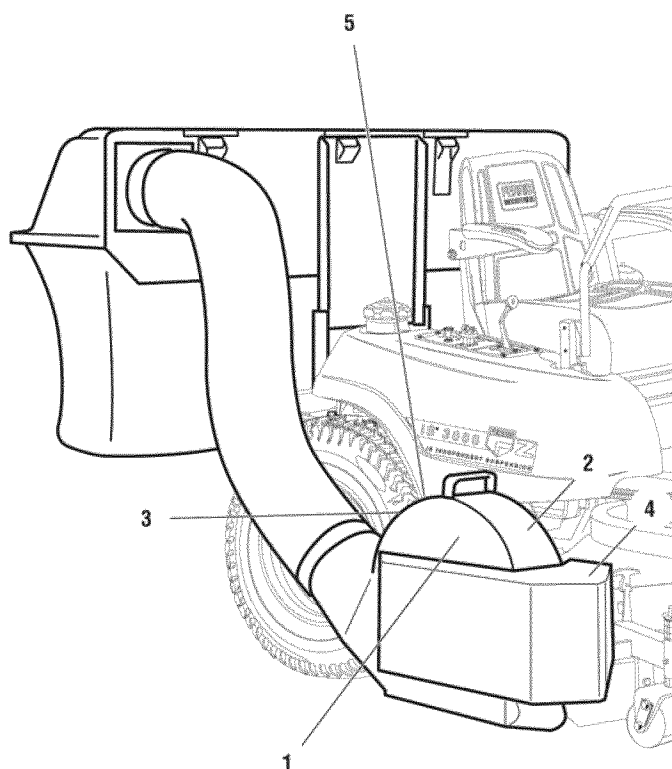

1 — **FAST-Vac**





BEFORE OPERATION

Clear the lawn of all sticks, stones, wire and other debris which may be caught or thrown by the mower blades.

Check grass condition. If wet, wait until later in the day. If grass is wet, the grass catcher is likely to become plugged.

For efficient bagging, air circulation under the mower deck, through the chute and into the bag is very important.

For this reason, BEFORE YOU BEGIN MOWING you should make certain the underside of the mower and the underside of the catcher lid are free from grass and debris.

Make sure that there is a snug fit between mower deck, blower housing, tubes, and grass catcher cover.

MOWING WITH THE DOUBLE / TRIPLE CATCHER

Always operate with throttle at full speed when mowing.

Always wear hearing protection when operating grass catcher.

Grass should be cut often, and not too short. If grass is too long or lush it may be necessary to keep ground speed to a minimum or to cut only half the width of the mower to prevent clogging. If grass is long, operate with mower in high cutting position for first pass, cutting again in a lower position on a second pass.

Do not open the cover with mower engaged.

If a large amount of cut grass is spilling out from under deck, the tube may be plugged or the bags may be full— discontinue mowing, stop the rider, disengage the PTO and then empty the catcher or clear the tube.

⚠ WARNING

ALWAYS shut off the tractor. disengage the PTO, and allow all moving parts to stop **BEFORE** disconnecting or clearing tube, or emptying catcher.

Before leaving the operator's position for any reason, engage the parking brake, disengage the PTO, stop the engine and remove the key.

To reduce fire hazard, keep the engine, rider and mower free of grass, leaves and excess grease. Do not stop or park rider over dry leaves, grass or combustible materials.

⚠ CAUTION



This machine produces sound levels in excess of 85 dBA at the operator's ear and can cause hearing loss though extended periods of exposure.

Wear hearing protection when operating this machine.

AFTER OPERATION

Remove any debris from the the screen on the underside of the lid. *Note: The lid screen can be partially removed for easier cleaning and should be cleaned regularly.*

The blower housing and tube should be removed for cleaning.

Inspect the grass bags for wear or damage. Make sure that there is a snug fit between mower deck, blower housing, tubes, and grass catcher cover.

STORING THE GRASS CATCHER

Clean the grass catcher thoroughly using a mild detergent (other products may damage the tube). Remove any debris from the the screen on the underside of the lid. The screen can be partially removed for easier cleaning.

If paint has been scratched on metal parts, touch up with paint, or apply a thin film of oil to prevent corrosion.

Store in a dry area. Hang the catcher and catcher bags to dry thoroughly before storing for a long period of time. Always store away from moisture.

MOWING WITHOUT THE BLOWER

For operation without the blower, the deflector must be properly installed in the down position.

To remove the blower, reverse the installation steps.

REAR SUSPENSION ADJUSTMENT

For IS1500Z & IS2000Z Models:

The upper mounting position #2 (See Figure 1) should be used when a rear-mount grass bagger system is installed.

To adjust the upper mounting position:

1. Park machine on a flat, level surface. Disengage the PTO, stop the engine and engage the parking brake.
2. Raise the rear of the machine and secure with jackstands. The jackstands must be under the bumper. Chock the front wheels to prevent the machine from rolling.
3. Position the jack under the cross member that ties the suspension arms together and slowly raise the rear suspension to relieve the pressure on the upper shock mounting bolts.

NOTE: This will require small adjustments to the jack's position. The shock should move freely on the mounting bolt when the pressure is relieved.

4. Remove the upper shock mounting hardware and pivot the shock to the position #2 (see Figure 1). Adjust the jack to align the shock mounts to the shocks.
5. Reinstall the upper shock mounting hardware and tighten securely.
6. Remove the jack from under the suspension cross member.
7. Remove the jackstands from under the machine.

For All Models:

More spring pre-load should be used with heavy weight operators.

WARNING

Use two hands when adjusting the shock springs. This will prevent the wrench from slipping while pressure is being applied.

To adjust the spring pre-load:

1. Park machine on a flat, level surface. Disengage the PTO, stop the engine and engage the parking brake.
2. Raise the rear of the machine and secure with jackstands. Chock the front wheels to prevent the machine from rolling.
3. Remove the rear drive tires.

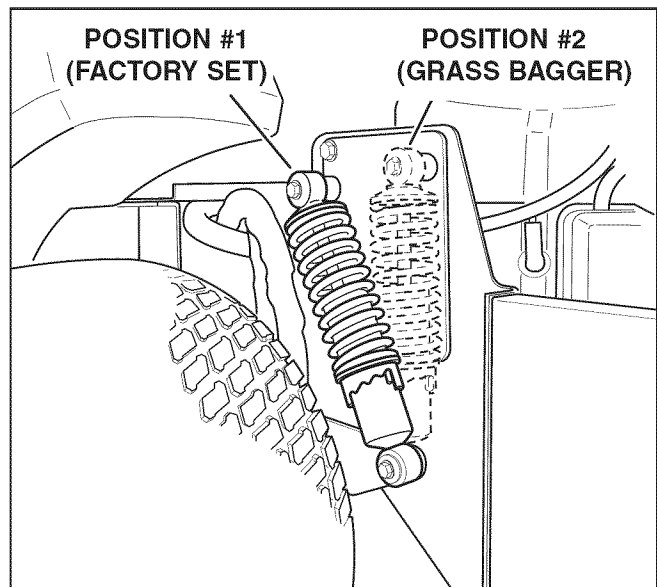

Figure 1. Rear Suspension Adjustments

4. See Figure 1. Using the supplied spanner wrench (p/n 5022853), insert the tip of the wrench into the notch in the pre-load adjuster. While holding the wrench in place with one hand, turn COUNTER-CLOCKWISE to increase the pre-load, turn CLOCKWISE to decrease the pre-load. Make sure both shocks are set to the same amount of pre-load.
5. Reinstall the rear drive tires. Torque the lug bolts to 85-95 ft/lbs. (115-129 Nm). Remove the jackstands from under the machine.

NOTE: Spanner wrench is located under the seat on the right-hand side of the machine.

BALL JOINT REPLACEMENT

For IS2000Z Models with 52" Mower Deck:

The existing ball joint (A, Figure 2) on the right-hand front suspension arm has to be replaced with the ball joint provided in the kit. This change is necessary to provide clearance for the blower unit and must be completed before blower unit installation.

To replace the ball joint:

1. Lower the front of the mower deck down on to wooden blocks to relieve the tension on the front deck hanger chains. Jack up the front of the tractor frame until the weight is lifted off of the front caster wheels.
2. Measure the amount of threads showing on the shank of the existing ball joint. See Figure 3.
3. Remove 3/4" bolt (E, Figure 4) that attaches the ball joint to the tractor frame (A). Discard the spacers (H and I) and 3/4" bolt (E).
4. Remove the ball joint (B) from the suspension arm (D).
5. Remove the jam nut (C) from the existing ball joint and thread onto the ball joint provided with kit (F). Discard the existing ball joint (B). Thread new ball joint into the suspension arm to the approximate measurement taken in step 2, allowing for correct orientation (Refer to Figure 4) of the ball joint to the tractor frame.
6. Install the ball joint stud through the 3/4" washer (G) and the tractor frame and tighten securing nut. Tighten jam nut on the shank of the ball joint against the suspension arm.
7. Lower the machine back down onto the caster wheels and remove the jack. Raise the mower deck to the transport position and remove the wooden blocks.

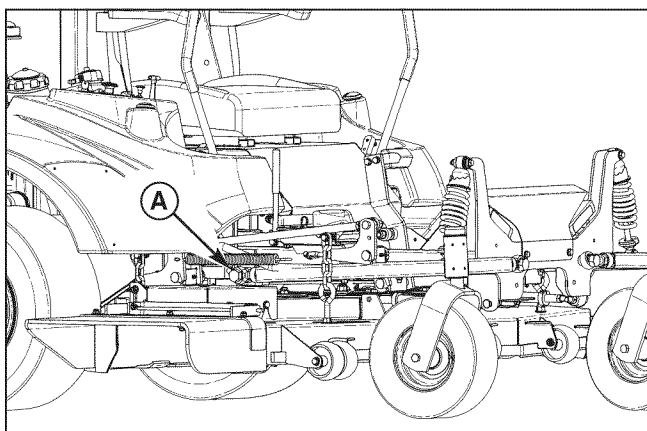

Figure 2. Location of Ball Joint
A. Ball Joint To Be Replaced

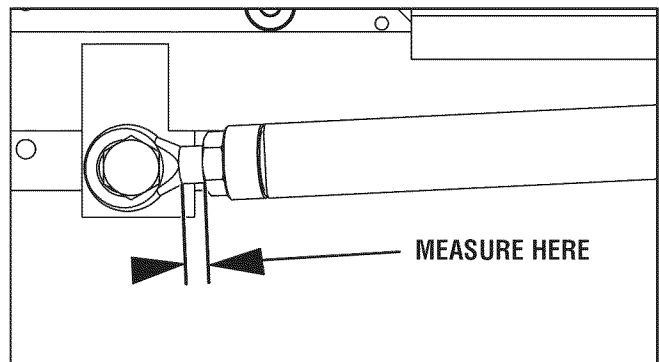

Figure 3. Measure Threads

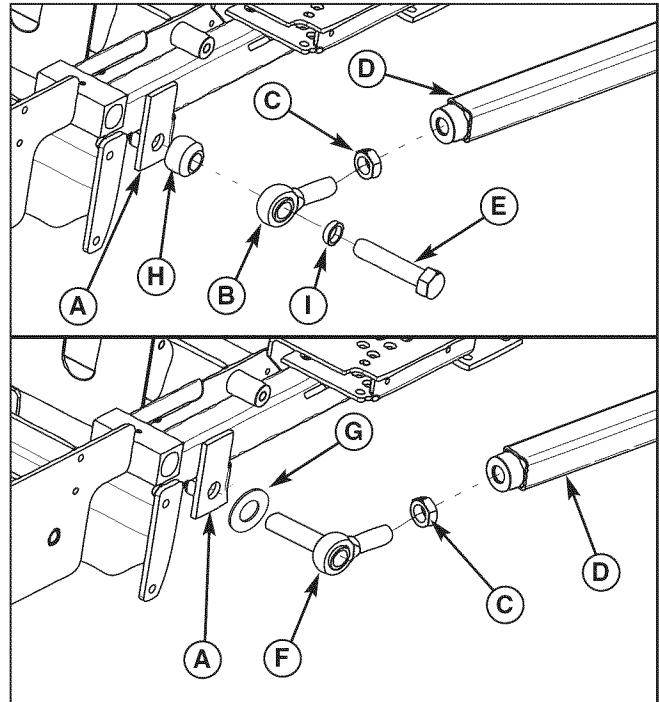

Figure 4. Ball Joints

- A. Frame
- B. Existing Ball Joint
- C. Jam Nut
- D. Suspension Arm
- E. 3/4" Bolt
- F. Ball Joint Provided In Kit
- G. 3/4" Washer Provided In Kit
- H. Spacer, .75 x 1.75 x 1.00
- I. Spacer, .75 x 1.00 x .25

BLOWER ASSEMBLY

Preparing the Mower Deck (IS4500Z Models Only)

1. Loosen the 3/8-24 hex nut (A, Figure 5) that secures the idler arm (C) to the blower assembly. Remove the idler arm assembly from the blower assembly.
2. Loosen the 1/2" hardware that secures the idler pulley (G) to the idler arm assembly. Remove the idler pulley from the idler arm assembly. Discard the bolt that secured the idler pulley to the idler arm assembly.
3. Refer to figure 6. Install the new 1/2-13 X 2-3/4" bolt (J) through the belt keep (I), which should be positioned with the tab facing up, then through the idler arm (C), then through the idler pulley spacer (H), and then through the idler pulley (G) which should be positioned with the hub facing up, and secure with the 1/2-13 hex nylon nut (F).
4. Set the idler arm assembly aside for reinstallation later.

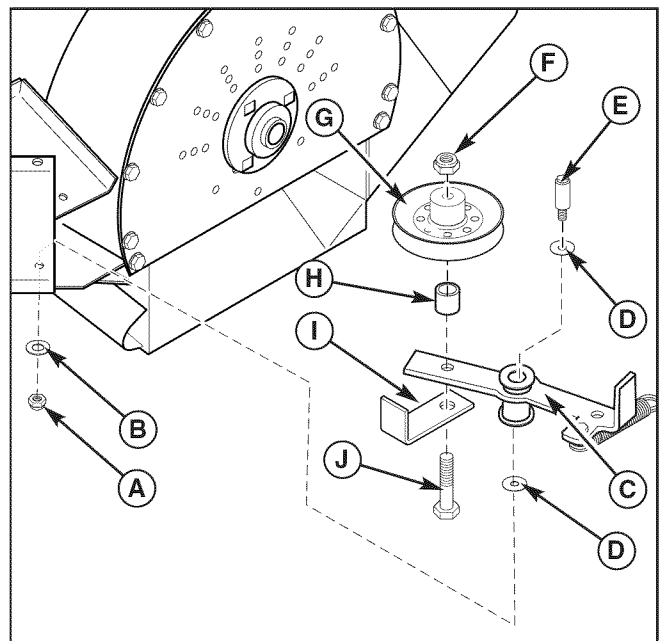

Figure 5. Updating the Idler Arm Assembly

- A. 3/8-24 Hex Nut
- B. 3/8 Lock Washer
- C. Idler Arm
- D. 9/16 Narrow Flat Washer
- E. Idler Stud
- F. 1/2-13 Hex Nylon Lock Nut
- G. Idler Pulley
- H. Idler Pulley Spacer, .52 X 1.00 X .44
- I. Belt Keep
- J. 1/2-13 x 2-3/4" Bolt

5. Loosen the 3/8-16 hex serrated flange nut (A, Figure 6) that secures the fixed idler pulley (D), and belt keep to the blower assembly.
6. Remove the 3/8-16 hex serrated flange nut (A) and the belt keep (B) from the 3/8-16 X 2" bolt (F).
7. Refer to figure 6. Install the .41 X 1.75 X .14 washer (C) onto the bolt above the top of the blower assembly. Reinstall the belt keep (B) with the tab facing down, and secure with the 3/8-16 hex serrated flange nut (A).

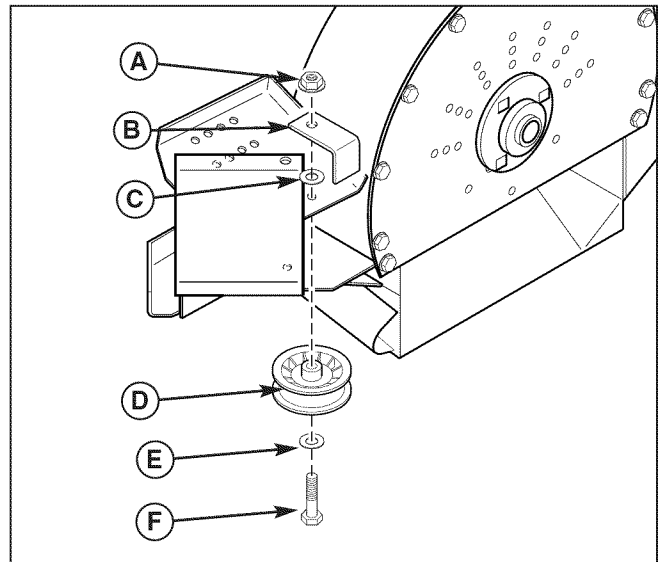

Figure 6. Installing the New Washer

- A. 3/8-16 Hex Serrated Flange Nut
- B. Belt Keep
- C. .41 X 1.75 X .14 Washer
- D. Fixed Idler Pulley
- E. 3/8" SAE Washer
- F. 3/8-16 X 2" Bolt

8. Loosen the 3/8-16 hex serrated flange nut (A, Figure 7) that secures the adjustable idler pulley (D) to the blower assembly. Remove the 3/8-16 hex serrated flange nut (A), and all the components the nut secured. Discard the 3/8-16 X 2" bolt.
9. Place the support plate (B) on the blower assembly. Line up the two rows of holes in the support plate with the two rows of holes on the blower assembly.
10. Refer to figure 7. Place a 3/8-16 X 3/4 Bolt (C) up through the blower assembly in the front most hole of the inner row, through the support plate (B) and secure with a 3/8-16 hex serrated flange nut (A).
11. Reassemble the adjustable idler pulley components as shown in Figure 7. Install the 3/8-16 X 2-1/2" bolt (H) up through the belt keep (G) which should be positioned with the tab facing up, through the .39 X .75 X .38 spacer (F), through the 3/8 SAE washer (E), through the adjustable idler pulley (D), which should be positioned with the hub facing up, then through the blower assembly, then through the support plate (B) and secure with a 3/8-16 hex serrated flange nut (A).
12. Using a 3/8" drill bit, drill a 3/8" hole through the blower assembly using the left rear hole (see Figure 7) as a guide.
13. Install a 3/8-16 X 3/4 bolt (C) up through the blower assembly in the newly drilled hole, through the support plate (B) and secure with a 3/8-16 hex serrated flange nut (A).
14. Reinstall the idler arm assembly to the blower assembly as shown in Figure 8. Install the idler stud (A, Figure 8) down through a 9/16 narrow flat washer (B) then down through the idler arm assembly (C), then down through another 9/16 narrow flat washer (B), then down through the blower assembly, then down through the 3/8 lock washer (D), and secure with the 3/8-24 hex nut (E).

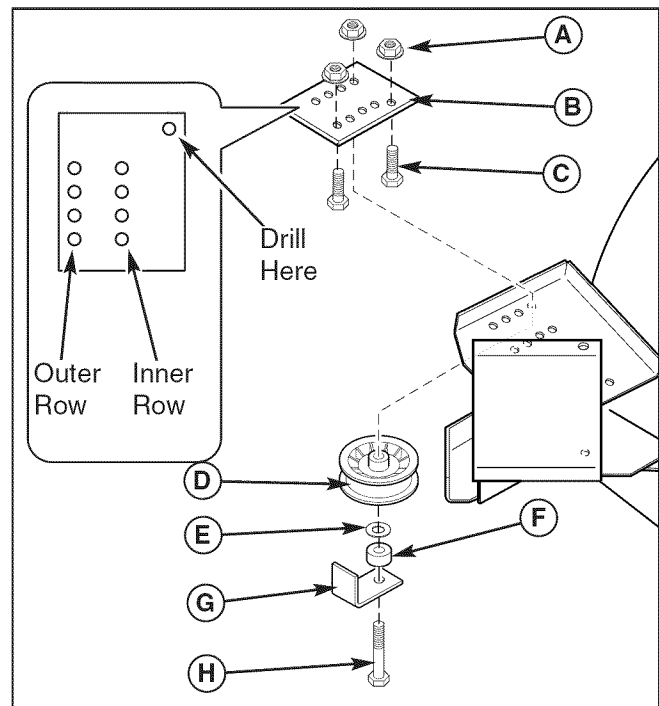

Figure 7. Installing the New Support Plate

- A. 3/8-16 Hex Serrated Flange Nut**
- B. Support Plate**
- C. 3/8-16 X 3/4 Bolt**
- D. Adjustable Idler Pulley**
- E. 3/8" SAE Washer**
- F. .39 X .75 X .38 Spacer**
- G. Belt Keep**
- H. 3/8-16 x 2-1/2" Bolt**

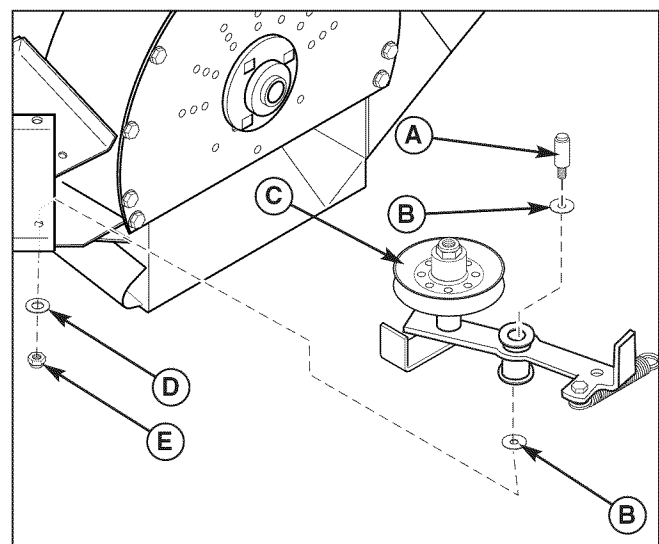

Figure 8. Updating the Idler Arm Assembly

- A. Idler Stud**
- B. 9/16 Narrow Flat Washer**
- C. Idler Arm Assembly**
- D. 3/8 Lock Washer**
- E. 3/8-24 Hex Nut**

Blower Assembly

1. Remove the existing 5/16-18 x 5/8" flange head bolts (B, Figure 9) from the blower housing (A).
2. Install the blower mount plate (C) onto the blower housing and reinstall the 5/16-18 x 5/8" flange head bolts. Tighten securely.
3. Install three (3) 3/8-16 x 1" bolts and nylon lock nuts (D) through the blower mount plate and blower. The bolt heads must be installed on the inside of the blower housing.

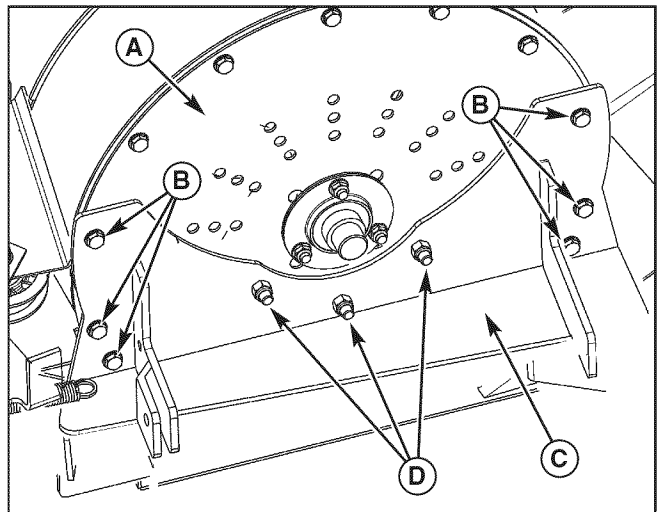

Figure 9. Install Blower Mount Plate

- A. Blower Housing
- B. 5/16-18 x 5/8" Bolts (existing)
- C. Blower Mount Plate
- D. 3/8-16 x 1" Bolts & Nylon Lock Nuts (3X)

4. Loop the idler spring (A, Figure 10) through the 1/4" x 2" eyebolt (B). Install the eyebolt through the L-bracket on the blower mount and install the 1/4-20 nylock flange nut (C). Tighten the nut until the eyebolt contacts the L-bracket.

Note: For 52" decks, the spring anchor bolt (D) has to be reversed. So that the idler spring can be attached to anchor bolt above the idler arm (E).

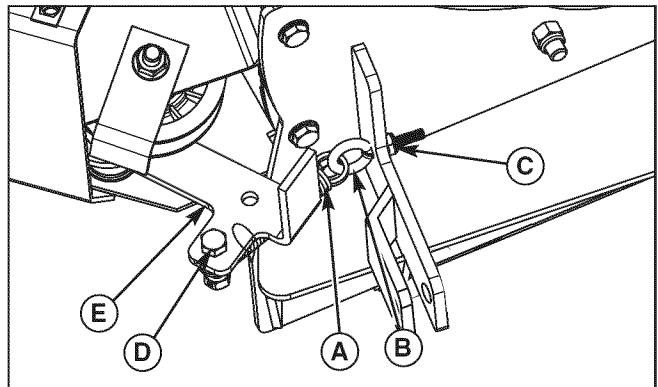

Figure 10. Install Idler Spring

- A. Idler Spring
- B. 1/4" x 2" Eyebolt
- C. 1/4-20 Nylock Flange Nut
- D. Spring Anchor Bolt
- E. Idler Arm

5. Remove the blower belt guard and set aside.

IS500Z, 1000Z, IS1000Z, IS1500Z, IS2000Z, IS3000Z, IS3100Z, S150X, S200X Series Models:

6. Install the impeller drive pulley (A, Figure 11) onto the impeller shaft (B) as described in Figure 11. Install the 1/4" x 1-1/2" long key (not shown) in the pulley.
7. Align the pulley groove with the appropriate slot as described in Figure 11. Tighten the set screws in the pulley.
8. Reposition the 3/8-16 x 6" bolt if required to line up with the pulley groove.

IS4500Z Models:

9. Loosely install the tapered hub (A, Figure 12) into the blower pulley (D). Install the blower pulley onto the impeller shaft (E) and slide the blower pulley in towards the blower assembly.
10. Position the new blower drive belt (B, Figure 12) in the blower drive pulley.
11. Position the blower pulley (D, Figure 12) so it is center with the belt keeper bolt (F). Install the 1/4" X 1-1/2" long key (C) into the blower pulley (D).
12. Install the two (2) 1/4-20 X 1" bolts (B) into the tapered hub (A) and tighten evenly. Torque the 1/4" bolts to 8 ft. lbs. (10,9 Nm).

All Models:

13. Check the position of the idler pulley (A, Figure 13). The position must be aligned with the position of the pulley (outer row of holes for pulley hub pointing in, inner row of holes for pulley hub pointing out). Reposition if necessary.

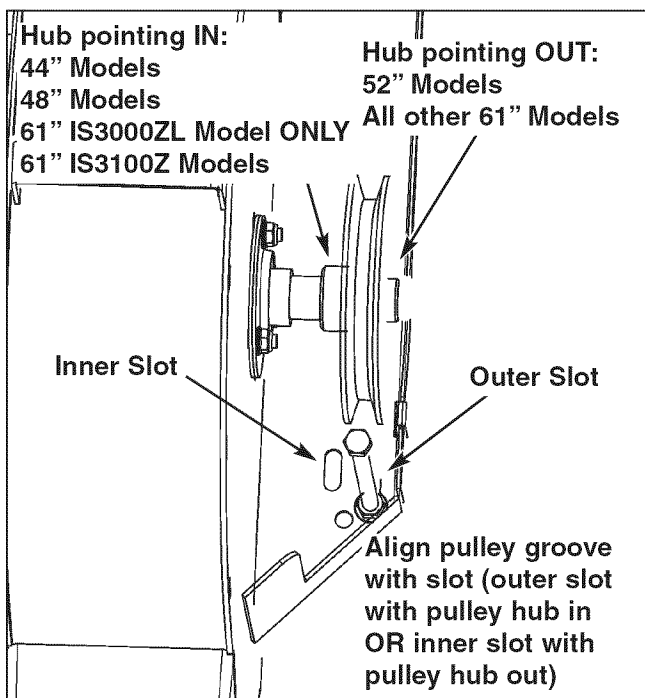

Figure 11. Install Impeller Drive Pulley

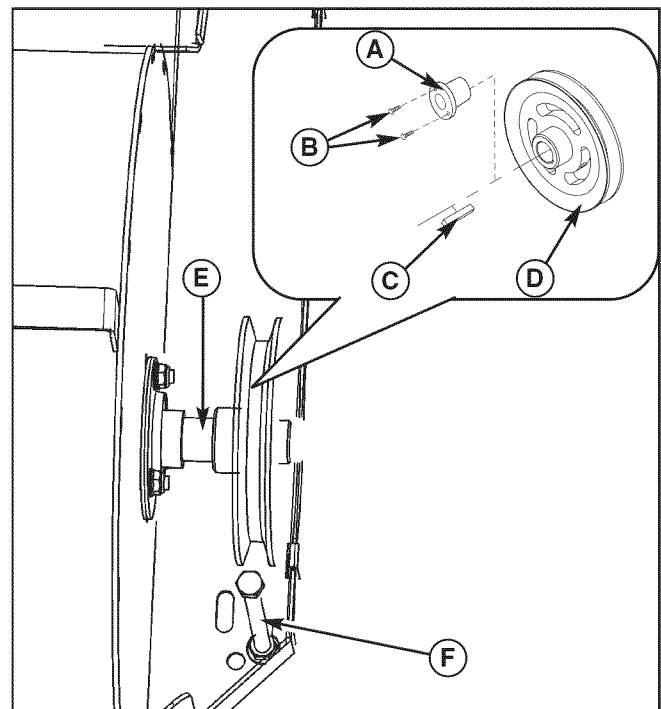

Figure 12. Install Impeller Drive Pulley (IS4500Z Models Only)

- A. Tapered Hub
- B. 1/4-20 X 1" Bolt
- C. 1/4 X 1-1/2" Long Key
- D. Blower Pulley
- E. Impeller Shaft
- F. Belt Keeper Bolt

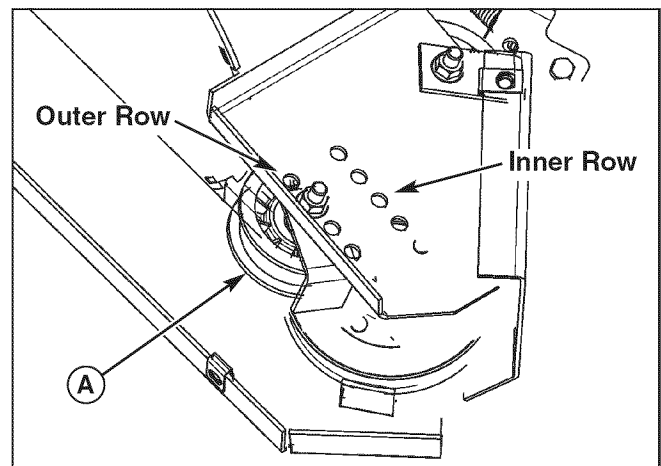

Figure 13. Check Idler Pulley Position
A. Idler Pulley

Remove the Discharge Chute

1. Remove the discharge chute (A, Figure 14), chute mount rod (B) and mounting hardware.
2. Remove the chute lock bolt (C) and nut.
3. Remove the deck guard (D). Save the bolts and washers, as they will be required in a later step.

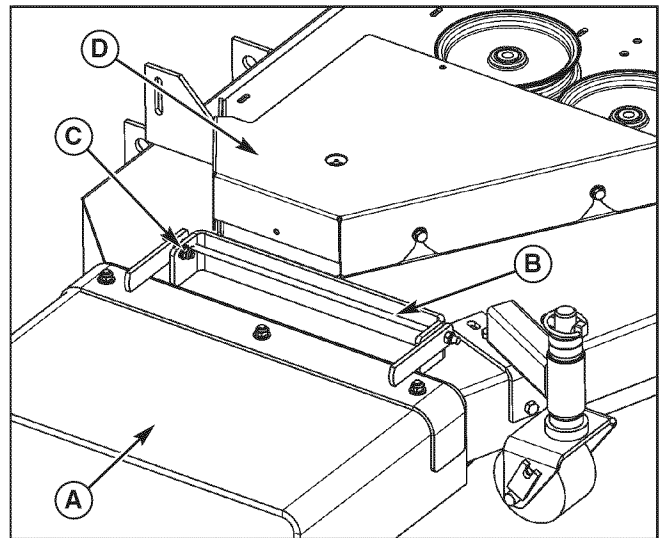

Figure 14. Remove Chute & Guard

- A. Discharge Chute
- B. Chute Mount Rod
- C. Chute Lock Bolt
- D. Guard

4. Examine the discharge chute mount bracket on the mower deck (see Figure 15). If the hole pattern looks like the one shown, you must drill a 3/8" hole in the location specified in Figure 15.

⚠ WARNING

IS500Z, 1000Z, IS1500Z, IS2000Z, IS3000Z, IS3100Z, IS4500Z, S150X & S200X Models:
Use extreme caution when rotating the idler arm with the breaker bar, due to the increased tension in the spring as the idler arm is being rotated. Injury may result if the breaker bar is prematurely released while the spring is under tension.

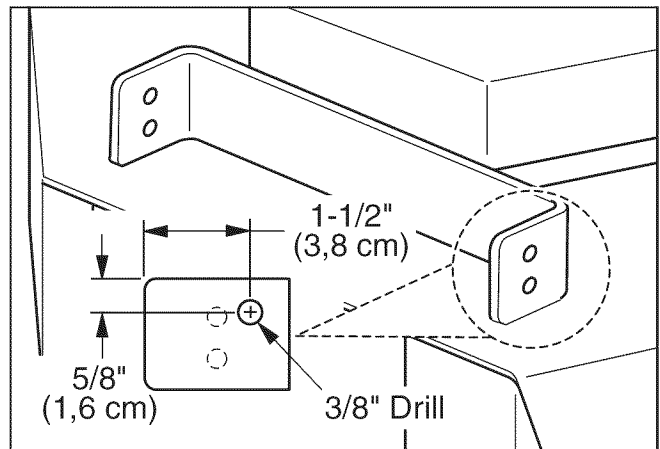

Figure 15. Discharge Chute Mount

Remove the Spindle Belt

IS500Z & IS1500Z Series:

1. Using a 1/2" breaker bar, place the square end in the square hole located in the end of the idler arm (A, Figures 16). Carefully rotate the breaker bar clockwise, which will relieve the tension on the belt exerted from the idler arm.
2. Slide the drive belt over the edge of the stationary idler pulley (B). Carefully release the tension on the breaker bar. Remove the belt from the right-hand (discharge side) spindle pulley.

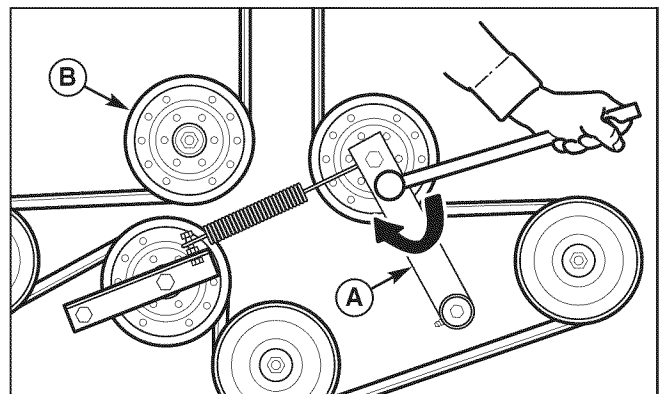

Figure 16. Mower PTO Belt

- A. Idler Arm
- B. Stationary Idler Pulley

IS1000Z Series (52" Model):

1. Loosen the spring compression nut (B, Figure 17) to release the belt tension.
2. Slide the drive belt over the edge of the idler pulley and then remove the belt from the right-hand (discharge side) spindle pulley.

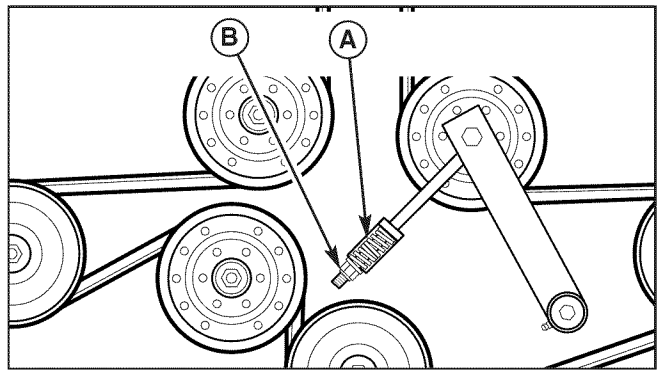

Figure 17. Mower PTO Belt
A. Belt Tension Spring
B. Spring Compression Nut

IS2000Z Series (52" Model):

1. Using a 1/2" breaker bar, place the square end in the square hole located in the end of the idler arm (A, Figures 18). Carefully rotate the breaker bar counter-clockwise, which will relieve the tension on the belt exerted from the idler arm.
2. Slide the drive belt over the edge of the stationary idler pulley (B). Carefully release the tension on the breaker bar. Remove the belt from the right-hand (discharge side) spindle pulley.

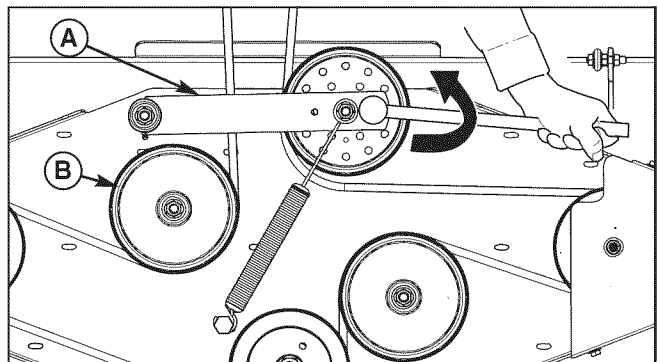

Figure 18. Mower PTO Belt
A. Idler Arm
B. Stationary Idler Pulley

1000Z Series (61" Model), IS2000Z Series (61" Model), IS3000Z Series & IS3100Z Series, S150X Series:

1. Using a 1/2" breaker bar, place the square end in the square hole located in the end of the idler arm (A, Figures 19). Carefully rotate the breaker bar counter-clockwise, which will relieve the tension on the belt exerted from the idler arm.
2. Slide the drive belt over the edge of the stationary idler pulley (B). Carefully release the tension on the breaker bar. Remove the belt from the right-hand (discharge side) spindle pulley.

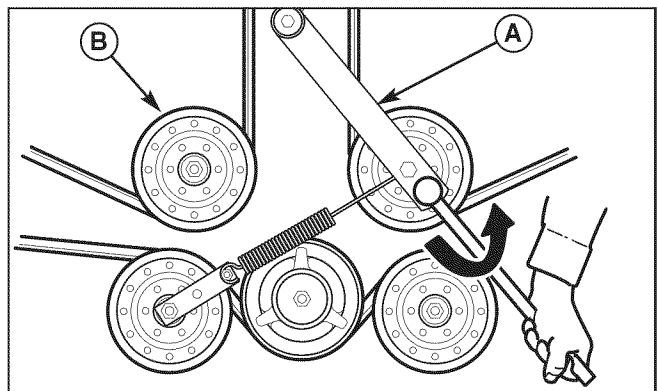

Figure 19. Mower PTO Belt
A. Idler Arm
B. Stationary Idler Pulley

Mower Deck Preparation

S200X Series:

1. Using a 1/2" breaker bar, place the square end in the square hole located in the end of the idler arm (A, Figures 20). Carefully rotate the breaker bar counter-clockwise, which will relieve the tension on the belt exerted from the idler arm.
2. Slide the drive belt over the edge of the stationary idler pulley (B). Carefully release the tension on the breaker bar. Remove the belt from the right-hand (discharge side) spindle pulley.

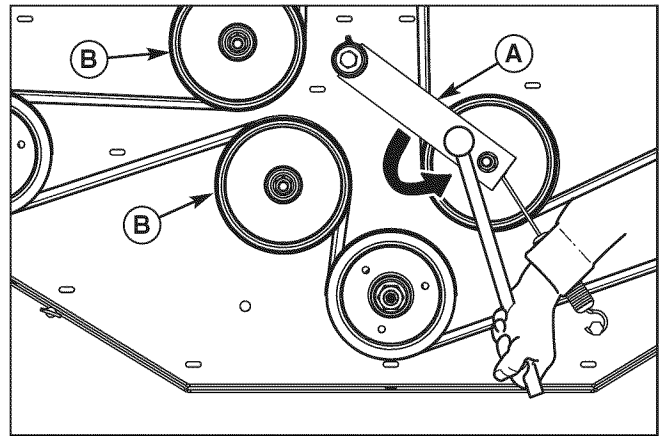

Figure 20. Mower PTO Belt
A. Idler Arm
B. Stationary Idler Pulley

IS4500Z Series:

1. Using a 1/2" breaker bar, place the square end in the square hole located near the end of the idler arm (A, Figures 21). Carefully rotate the breaker bar clockwise, which will relieve the tension on the belt exerted from the idler arm.
2. Remove the belt from the trim side spindle pulley (B).
3. Carefully release the tension on the breaker bar.
4. Remove the belt from the right-hand (discharge side) spindle pulley.

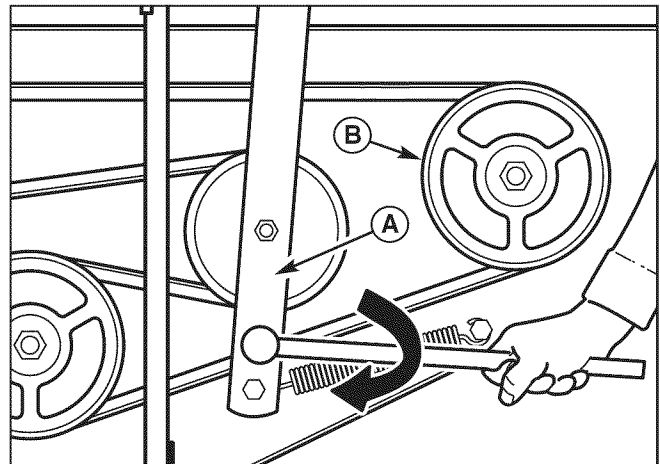

Figure 21. Spindle Drive Belt Removal
A. Idler Arm
B. Trim Side Spindle Pulley

Remove the Spindle Pulley

IS500Z Series, 1000Z Series, IS1000Z Series, IS1500Z, IS2000Z, IS3000ZF & ZX Series, S150X & S200X Series:

1. Remove the 3/4-16 hex nut & 3/4" spring washer (A & B, Figure 22) securing the spindle pulley (C) to the spindle shaft. Use a 1" wrench on the flats of the blade end of the spindle shaft to prevent the shaft from spinning. Save the 1/4" key (D).

IS3000ZL Series, IS3100Z Series, & IS4500Z Series:

1. Measure and record the distance between the bottom of the spindle pulley and the top of the mower deck. This will be required when installing the new pulley.
2. Remove the 1/4-20 x 1" bolts (E) securing the tapered hub (F) to the spindle pulley (G) and shaft.
3. Reinstall the bolts in the tapped holes of the tapered hub and tighten evenly to remove the hub from the pulley and shaft. Use a 1" wrench on the flats of the blade end of the spindle shaft to prevent the shaft from spinning. Save the 1/4" key (D).

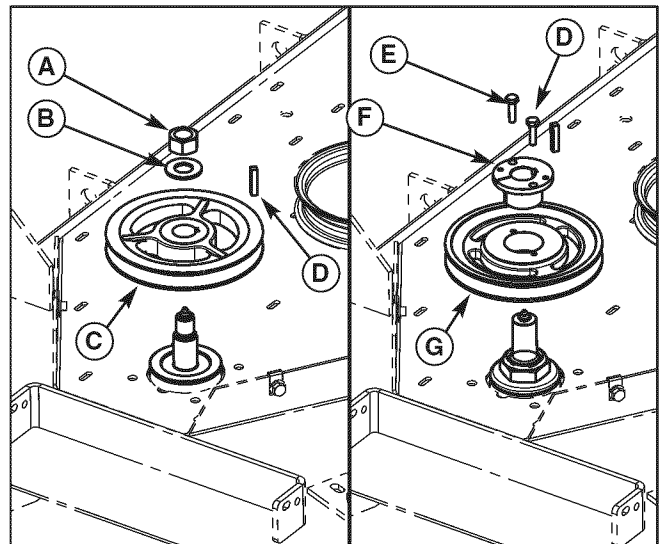

Figure 22. Remove Spindle Pulley

- A. 3/4-16 Hex Nut
- B. 3/4" Spring Washer
- C. Spindle Pulley
- D. 1/4" Key
- E. 1/4-20 x 1" Bolts
- F. Tapered Hub
- G. Spindle Pulley (tapered bore)

Install the Double Spindle Pulley

IS500Z Series, 1000Z Series, IS1000Z Series, IS1500Z, IS2000Z, IS3000ZF & ZX Series, S150X & S200X Series:

1. Install the double spindle pulley (C, Figure 22) and 1/4" key (D) onto the spindle shaft.
2. Install the 3/4" spring washer (B) with the cone facing up (see insert, Figure 22). Install the 3/4-16 hex nut (A) and torque to 85-90 ft. lbs (115-122 Nm). Use a 1" wrench on the flats of the blade end of the spindle shaft to prevent the shaft from spinning.

IS3000ZL Series, IS3100Z Series, & IS4500Z Series:

1. Remove the 1/4-20 x 1" bolts (E) from the tapered hub (F). Install the bolts through the clearance holes in the hub and into the new double spindle pulley (G).
2. Install the pulley, hub and 1/4" key (D) onto the spindle shaft.
3. Hold the pulley at the height measure previously and tighten the 1/4" bolts evenly. Torque the 1/4" bolts to 8 ft. lbs. (10.9 Nm). Use a 1" wrench on the flats of the blade end of the spindle shaft to prevent the shaft from spinning.

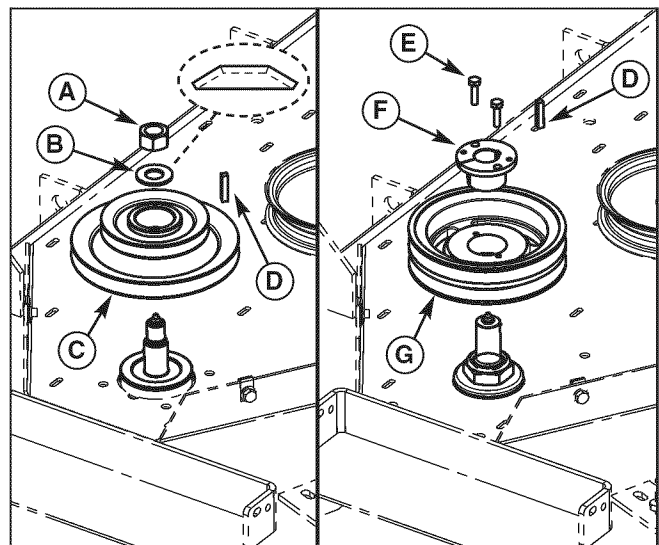

Figure 23. Install Double Spindle Pulley

- A. 3/4-16 Hex Nut
- B. 3/4" Spring Washer
- C. Double Spindle Pulley
- D. 1/4" Key
- E. 1/4-20 x 1" Bolts
- F. Tapered Hub
- G. Double Spindle Pulley (tapered bore)

Mower Deck Preparation

Reinstall the Spindle Belt

Refer to the belt removal instructions on Page 10, 11, & 12 and reverse the order for reinstalling the belt.

Install the Deck Guard

1. Install the new deck guard onto the mower deck and secure with the hardware previously removed (see Figure 24).

NOTE: The IS2000Z with 52" deck has a 2-piece deck guard. Install as shown in Figure 25.

NOTE: The IS4500Z Series has a 3-piece deck guard. Install as shown in Figure 26.

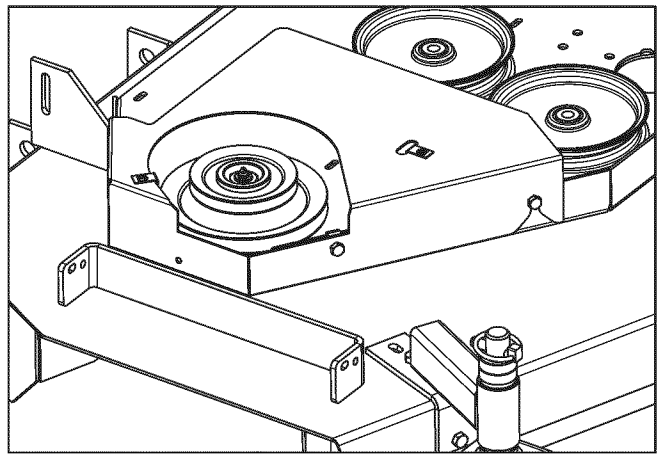

Figure 24. Install Guard

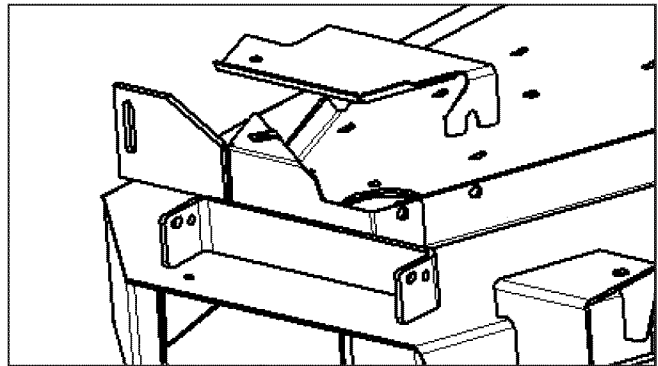

Figure 25. Install Guard - IS2000Z with 52" Deck

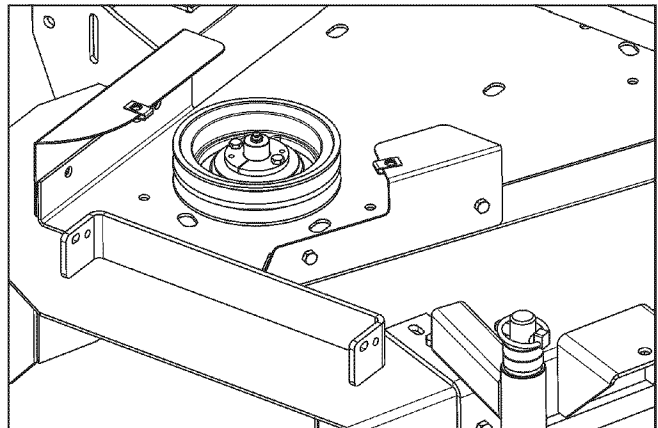

Figure 26. Install Guard - IS4500Z Series

1. Install the blower onto the mower deck. Refer to Figure 27 for the position of the quick pins in relationship to the chute mount bracket on the mower deck. The quick pins fit into the same holes that the chute mount rod was installed.

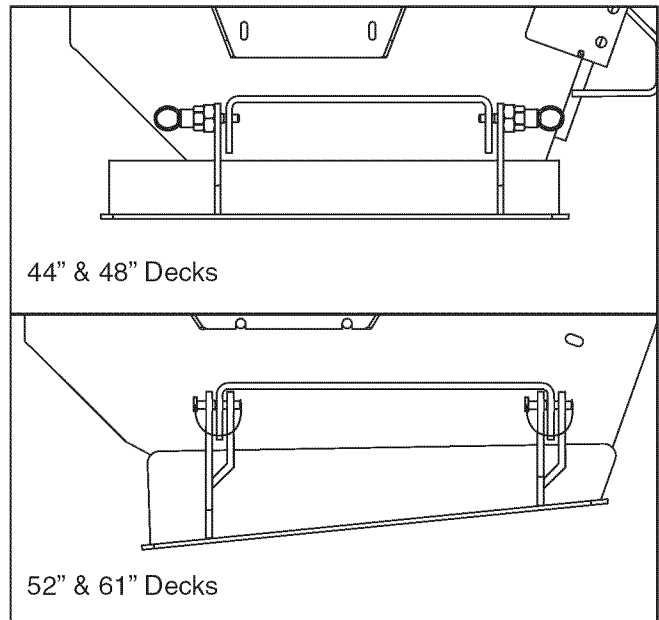

Figure 27. Install Blower On Deck (Notice Pin Orientation)

2. Install the blower drive belt. Refer to Figure 28 for the proper belt routing. It may be required to loosen the idler pulley mounting hardware to get the belt past the belt keeps.

IMPORTANT NOTE: *The gray area denotes the flat side of the belt. V-side of belt must contact v-groove pulleys, flat side of belt must contact flat pulleys.*

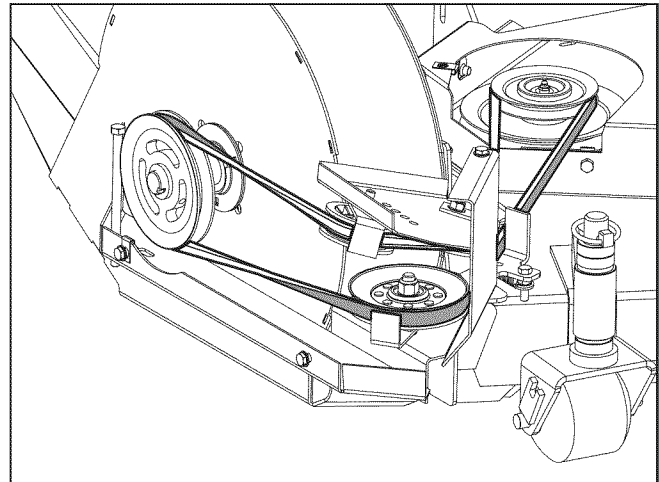

Figure 28. Install Belt

Blower Installation

3. Check the belt tension by measuring the distance from the center of the v-idler pulley (A, Figure 29) mounting bolt and the blower housing. This should measure between 3 - 3-3/8" (7,6 - 8,6 cm).
4. If measurement falls outside of this range, you must move the idler pulley (B) either forward or back to achieve the proper belt tension.

NOTE: If pulley position needs to be adjusted, make sure that it is reinstalled in the same row of holes as determined in the blower assembly (Step 13, page 11).

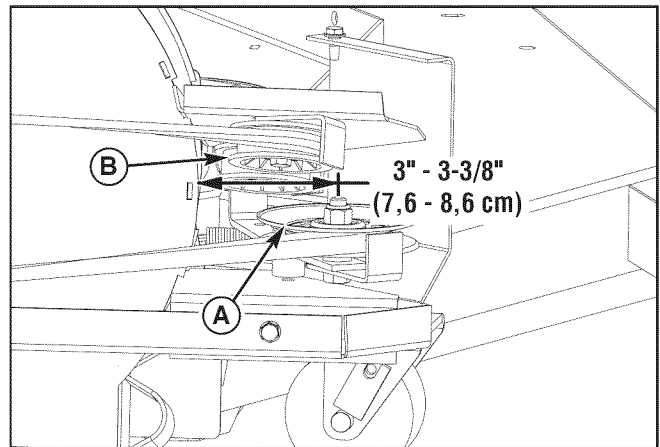

Figure 29. Check Belt Tension
A. V-Idler Pulley
B. Idler Pulley

5. Install the blower belt guard (A, Figure 30) and secure with the flange head bolts previously removed.
6. Install the deck guard top (B) and secure with the supplied knobs (C).

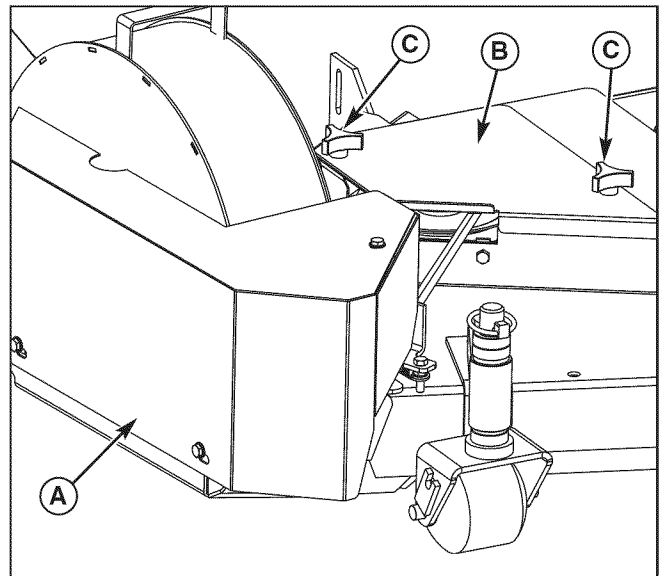

Figure 30. Install Guards
A. Blower Belt Guard
B. Deck Guard Top
C. Knob

Install Collector Mount Plate

(1000Z & IS1000Z Series)

1. Remove the hardware securing the rear bumper screen (A, Figure 31) to the top and bottom bumpers (A, B). Save the 3/8" bolts and washers from the lower bumper.

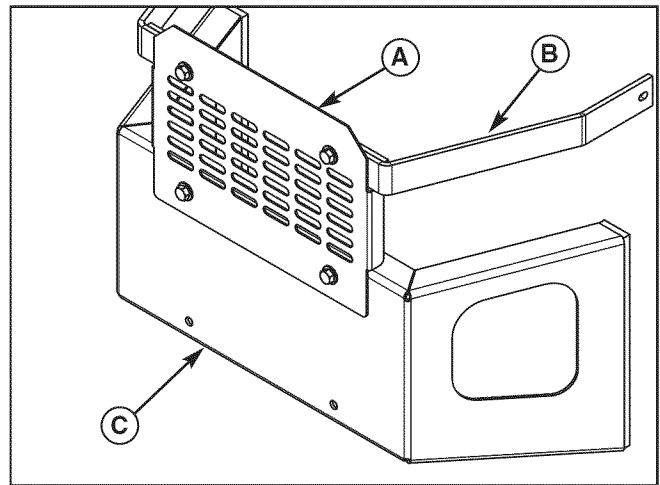

Figure 31. Remove Bumper Screen

- A. Screen
- B. Top Bumper
- C. Lower Bumper

2. Install the collector mount plate (A, Figure 32) on to the lower bumper and secure with the previously removed 3/8" bolts, 3/8" washers (B) and new 3/8-16 nylock flange nuts (E).
3. Install the 3/8-16 x 1-1/2" bolts and 3/8" washers (C) through the top mount holes as shown in Figure 31. Install the support bar (D) and secure with the 3/8-16 nylock flange nuts (E).

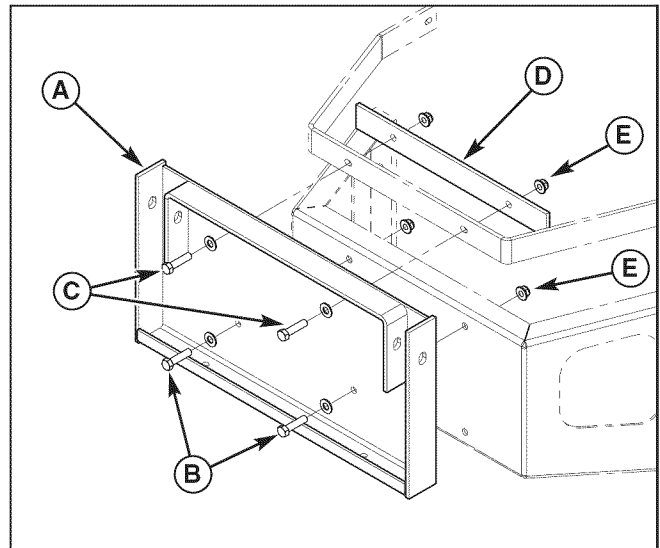

Figure 32. Install Collector Mount Plate

- A. Mount Plate
- B. 3/8" Bolts & Washers (previously removed)
- C. 3/8-16 x 1-1/2" Bolts & 3/8" Washers
- D. Support Bar
- E. 3/8-16 Nylock Flange Nuts

Collector Installation

Install Collector Mount Plate

(IS500Z Series, IS1500Z Series, IS2000Z Series, & IS4500Z Series)

IMPORTANT NOTE: If the collector system is being installed on an IS4500Z Series model, the Extreme Duty Rear Bumper Kit (5600019) must be installed first.

1. Install the collector mount plate (A, Figure 33) and mount tabs (B) on to the bumper. Install two of the 3/8-16 U-bolts (C) over the top bumper tube and through the mount tabs and loosely secure with the 3/8-16 nylock flange nuts (F).

NOTE: On IS500Z models use the inner mounting holes when installing the collector mount plate and mount tabs to the bumper with the 3/8-16 U-bolts

2. Install the remaining 3/8-16 U-bolt bolt (C) over the middle bumper tube and loosely secure with the 3/8-16 nylock flange nuts (E).
3. Center mount plate on the bumper and tighten all the hardware securely.

4. Temporarily install the collector mount posts (A, Figure 34) into the collector plate and install the hitch pins (B). This will insure that the holes are properly aligned for easy installation and removal.
5. Tighten the top nuts (C) securely and remove the hitch pins and mount posts.

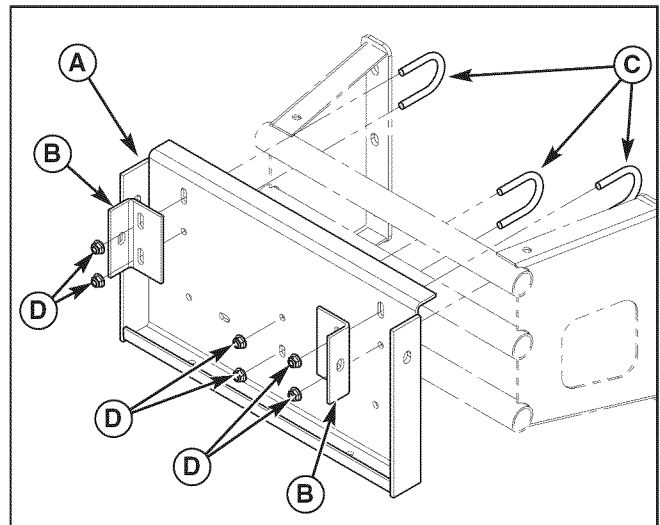

Figure 33. Install Collector Mount Plate

- A. Mount Plate
- B. Mount Tab
- C. 3/8-16 U-Bolts
- D. 3/8-16 Nylock Flange Nuts

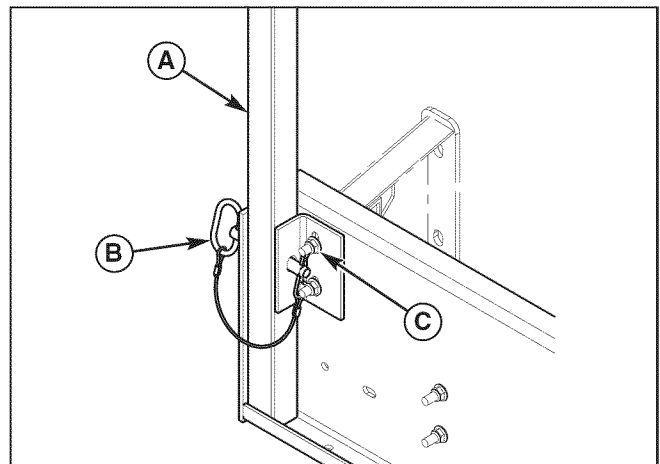

Figure 34. Install Mount Posts & Hitch Pins

- A. Mount Post
- B. Hitch Pin
- C. 3/8-16 Nylock Flange Nuts

Remove the Rear Engine Shield

(IS3100Z with 4-Tube Rear Bumper)

1. If the engine is hot, allow sufficient time for the muffler to cool to prevent a burn injury during installation.
2. Remove the rear engine shield (C, Figure 35) from the top of the rear bumper (D) by removing the 3/8" hardware (A, B, & E) securing the shield to the bumper.

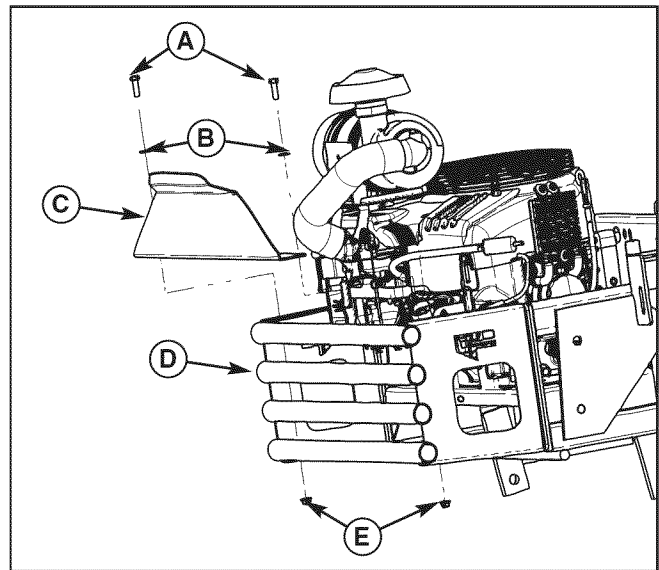

Figure 35. Remove the Rear Engine Shield

- A. 3/8-16X1" Bolts
- B. 3/8" Washers
- C. Rear Engine Shield
- D. Rear Bumper
- E. 3/8" Nylon Flange Nuts

Install Collector Mount Plate

(IS3100Z Series with 4-Tube Rear Bumper)

1. Install the collector mount plate (A, Figure 36) on to the bumper. Install two of the 3/8-16 U-bolts (C) over the top bumper tube and through the mounting plate and loosely secure with the 3/8-16 nylock flange nuts (B).
2. Install the remaining 3/8-16 U-bolt bolt (C) over the third tube down from the top of the bumper and loosely secure with the 3/8-16 nylock flange nuts (B).
3. Center mount plate on the bumper and tighten all the hardware securely.

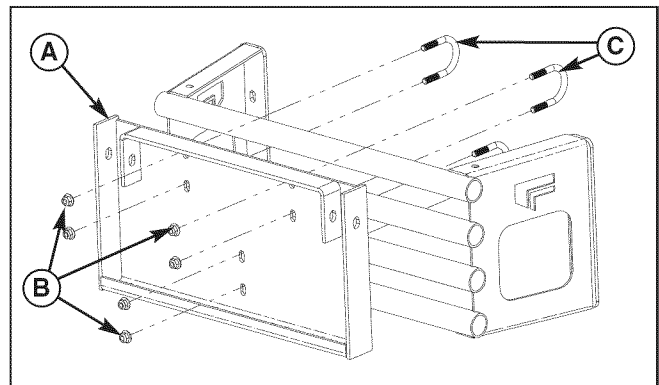

Figure 36. Install Collector Mount Plate

- A. Mount Plate
- B. 3/8-16 Nylock Flange Nuts
- C. 3/8-16 U-Bolts

Install Collector Mount Plate

(IS3100Z Series with 5-Tube Rear Bumper)

1. Install the collector mount plate (A, Figure 37) on to the bumper. Install two of the 3/8-16 U-bolts (C) over the second tube down from the top of the bumper and through the mounting plate and loosely secure with the 3/8-16 nylock flange nuts (B).
2. Install the remaining 3/8-16 U-bolt bolt (C) over the fourth tube down from the top of the bumper and loosely secure with the 3/8-16 nylock flange nuts (B).
3. Center mount plate on the bumper and tighten all the hardware securely.

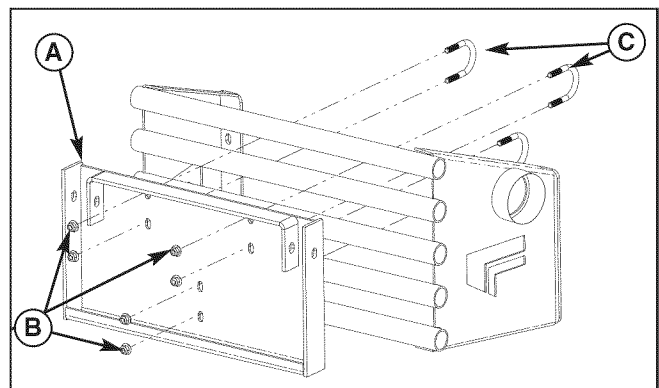

Figure 37. Install Collector Mount Plate

- A. Mount Plate
- B. 3/8-16 Nylock Flange Nuts
- C. 3/8-16 U-Bolts

Install Collector Mount Plate

(IS3000Z Series)

1. Install the collector mount plate (A, Figure 38) and mount tabs (B) on to the bumper. Install the 3/8-16 x 2-3/4" bolts (C) through the mount tabs and loosely secure with the clamp bars (D) and 3/8-16 nylock flange nuts (F).
2. Install the 3/8-16 x 2-1/2" bolts (E) through the bottom mounting holes and loosely secure with the clamp bars (D) and 3/8-16 nylock flange nuts (E).
3. Center mount plate on the bumper and tighten all the hardware securely.

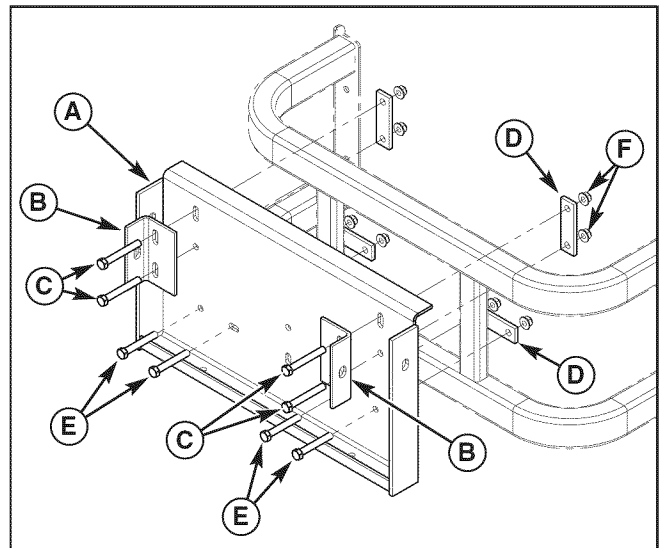

Figure 38. Install Collector Mount Plate

- A. Mount Plate
- B. Mount Tab
- C. 3/8-16 x 2-3/4" Bolt
- D. Clamp Bar
- E. 3/8-16 x 2-1/2" Bolt
- F. 3/8-16 Nylock Flange Nut

4. Temporarily install the collector mount posts (A, Figure 39) into the collector plate and install the hitch pins (B). This will insure that the holes are properly aligned for easy installation and removal.
5. Tighten the top mounting bolts (C, Figure 38) securely and remove the hitch pins and mount posts.

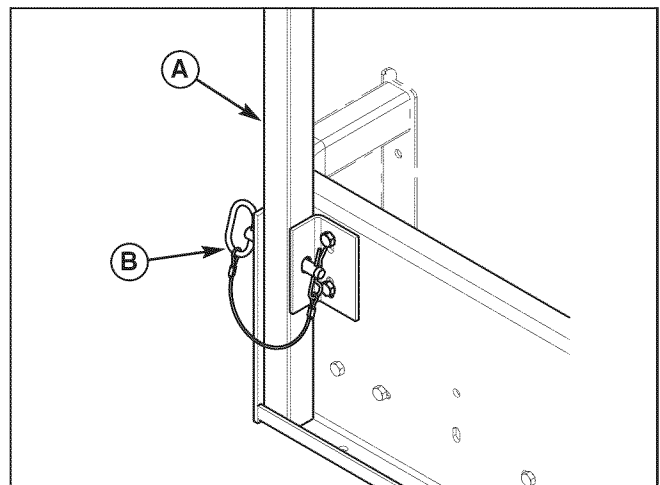

Figure 39. Install Mount Posts & Hitch Pins

- A. Mount Post
- B. Hitch Pin

Install Collector Mount Plate

(S150X & S200X Series)

1. Remove the carb. shield plate from top of the rear bumper.
2. Install the collector mount plate (A, Figure 40) and mount tabs (B) on to the bumper. Install the 3/8-16 x 1-1/4" bolts (C) and 3/8" SAE washers (F) through the mount tabs and loosely secure with the 3/8-16 nylock flange nuts (E).
3. Install the 3/8-16 x 1" bolts (D) and 3/8" SAE washers (F) through the bottom mounting holes and loosely secure with the 3/8-16 nylock flange nuts (E).
4. Tighten the bottom mounting bolts securely.

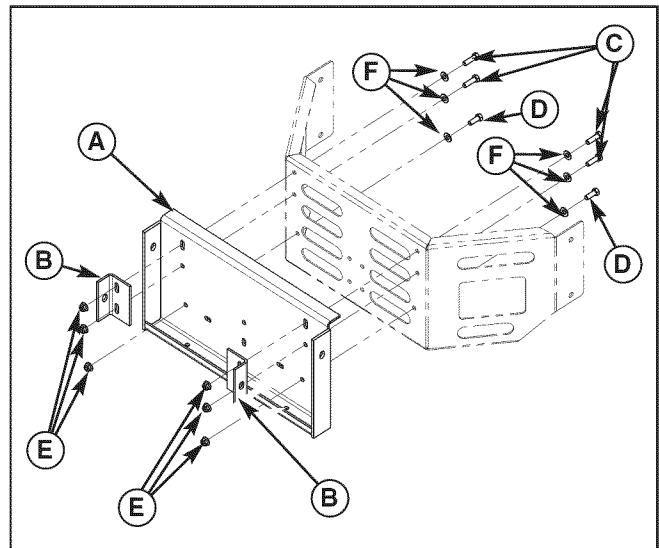

Figure 40. Install Collector Mount Plate

- A. Mount Plate
- B. Mount Tab
- C. 3/8-16 x 1-1/4" Bolt
- D. 3/8-16 x 1" Bolt
- E. 3/8-16 Nylock Flange Nut
- F. 3/8" SAE Washers

5. Temporarily install the collector mount posts (A, Figure 41) into the collector plate and install the hitch pins (B). This will insure that the holes are properly aligned for easy installation and removal.
6. Tighten the top mounting bolts (C, Figure 37) securely and remove the hitch pins and mount posts.

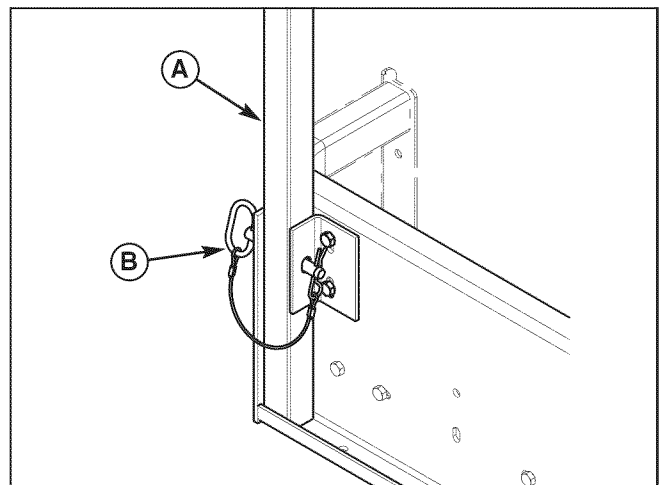

Figure 41. Install Mount Posts & Hitch Pins

- A. Mount Post
- B. Hitch Pin

Collector Installation

Assemble Collector Hood

1. Install the inlet tube (B, Figure 42) to the collector back plate (A) and secure with the 5/16-18 x 3/4" bolts (C) and 5/16-18 nylock flange nuts (D).
2. Install the mount posts (E) on the back plate and loosely secure with the 3/8-16 x 1" bolts (F) and 3/8-16 nylock flange nuts (G).

NOTE: On the 3-bag collector back plate, install the eight (8) supplied hole plugs in the remaining mounting holes not used.

3. Install the collector onto the mount plate and secure with the hitch pins as shown in Figure 38. Again, this will insure that the holes are properly aligned for easy installation and removal.. Tighten the 3/8-16 x 1" bolts securing the posts to the back plate.

NOTE: It is recommended that the rear suspension be adjusted stiffer due to the added weight of the collection system (see operators manual for procedure).

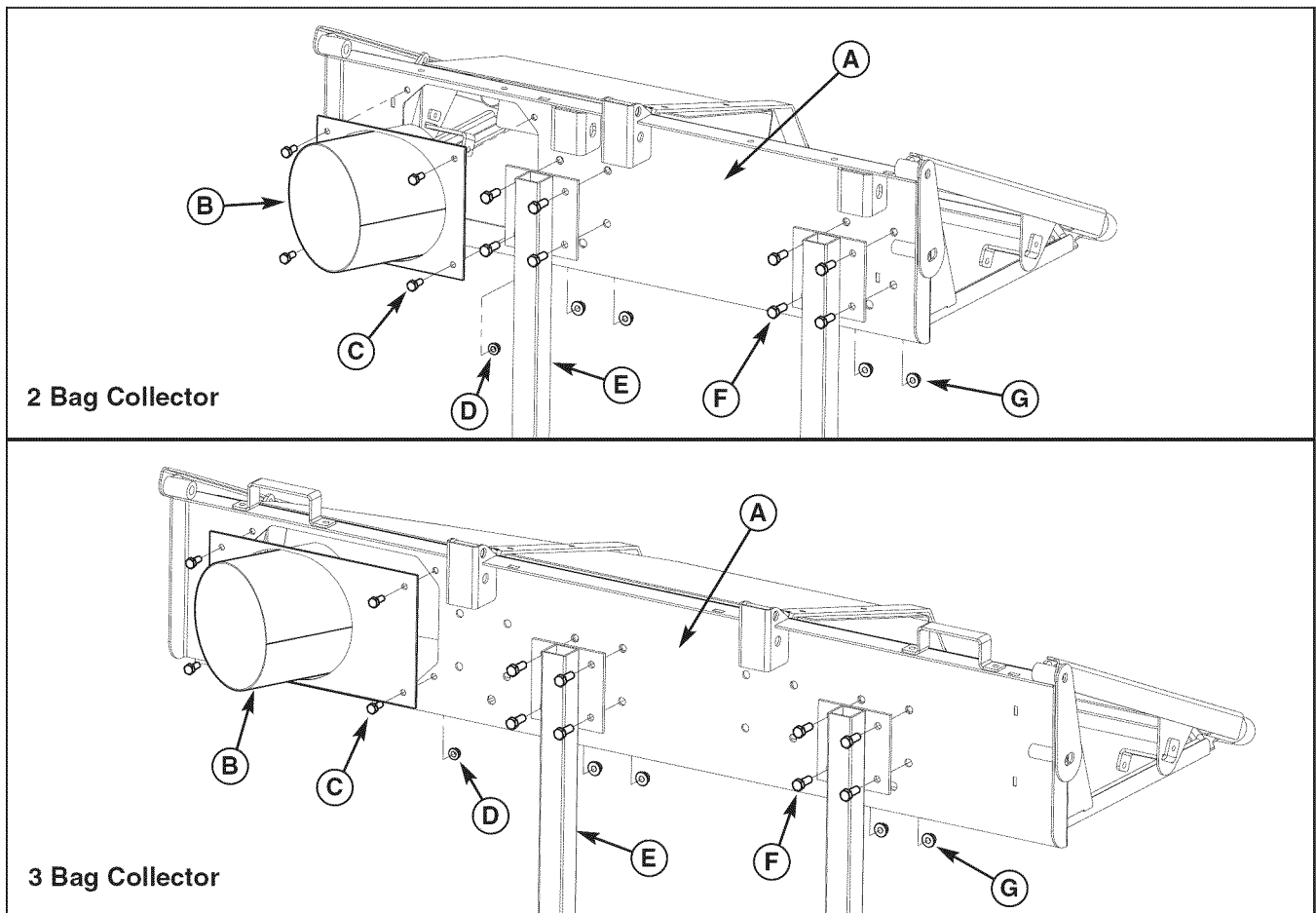

Figure 42. Assemble Collector Hood

- A. Collector Back Plate
- B. Inlet Tube
- C. 5/16-18 x 3/4" Bolt
- D. 5/16-18 Nylock Flange Nut
- E. Collector Mount Post
- F. 3/8-16 x 1" Bolt
- G. 3/8-16 Nylock Flange Nut

Install Collector Bags

1. Raise the collector hood and slide the collector bags (A, Figure 43) onto the frame rails (B).

NOTE: The collector bags are constructed with three mesh panels and one solid panel. Install the bag with the solid panel towards the front of the machine.

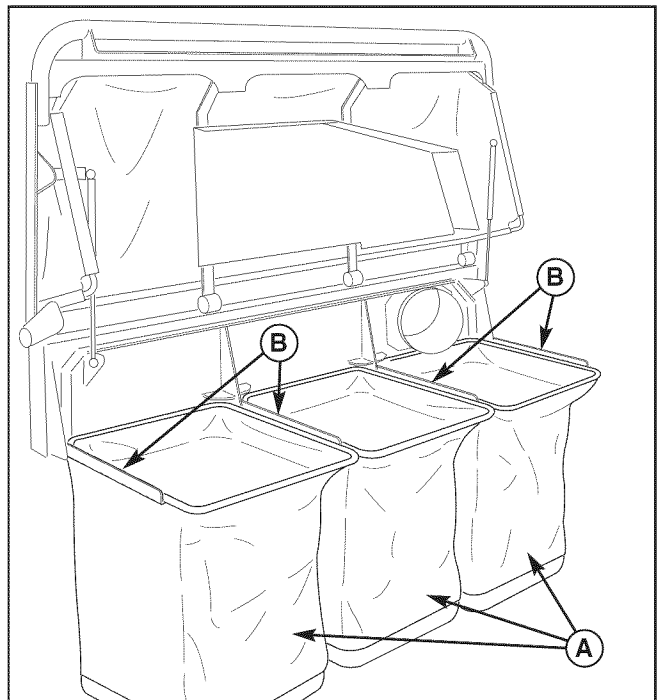

Figure 43. Install the Collector Bags

- A. Collector Bag**
- B. Frame Rails**

2. Lower the hood and push the lock pin (B, Figure 44) through the hood lock plate (A).

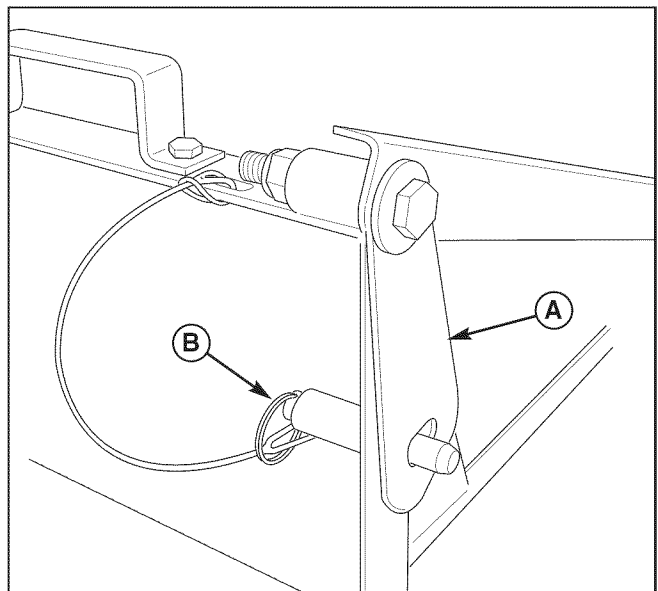

Figure 44. Lock Hood

- A. Hood Lock Plate**
- B. Lock Pin**

Install Hose

1. Lower the mower deck to the lowest cutting position.
2. See Figure 45. Install the hose (A) onto the blower and secure with the removable clamp (with knob) (B). At least two bands must cover the outlet of the blower (C).
3. Cut the hose to fit properly between the blower and collector as shown in Figure 45. At least two bands must cover the inlet of the collector (D). Secure with the stationary clamp (E).

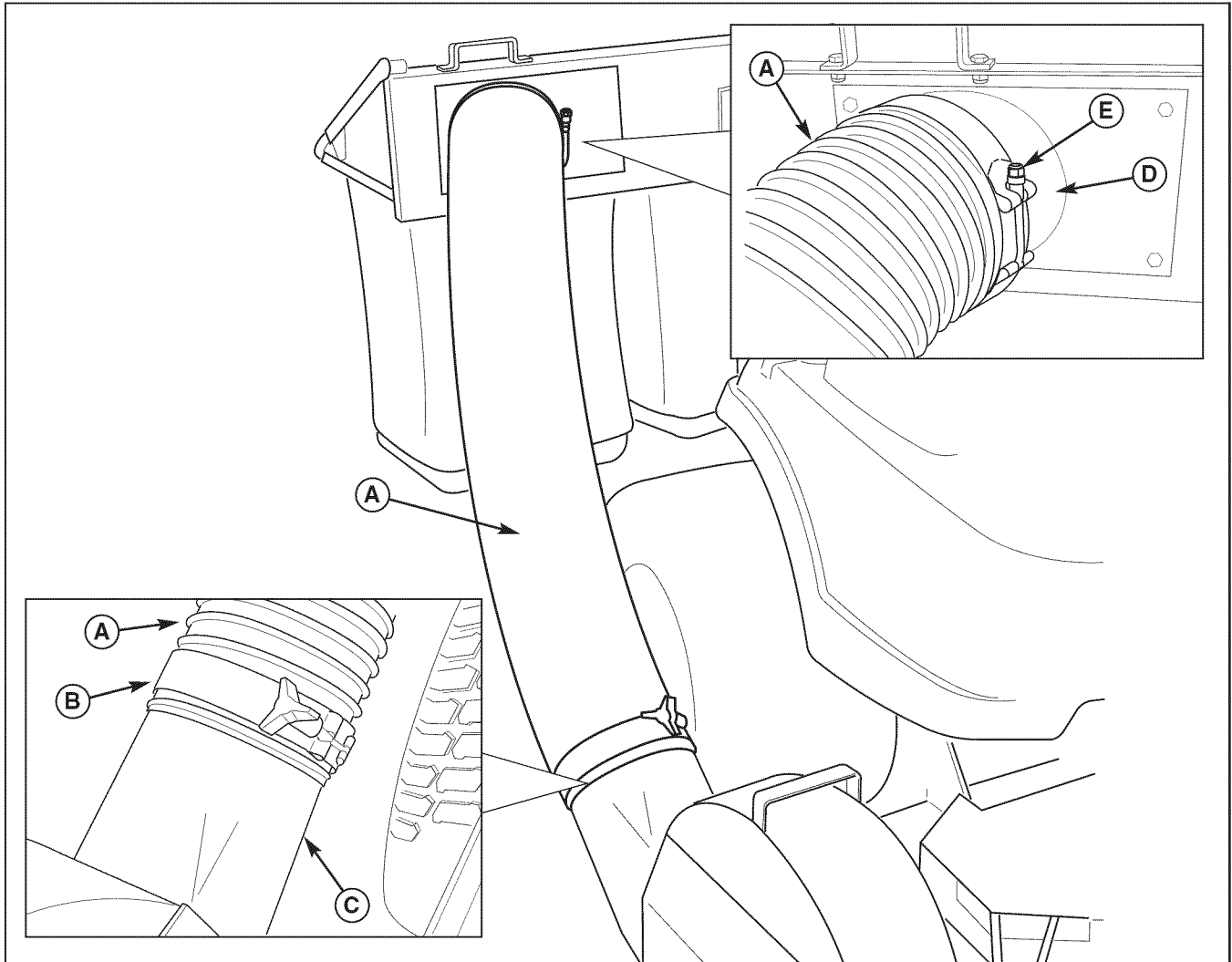

Figure 45. Install Hose

- A. Hose
- B. Removable Clamp (with knob)
- C. Blower Outlet
- D. Collector Inlet
- E. Stationary Clamp

Install Weight Carrier

1. Remove the hairpin clip and clevis pin and remove the deck lift foot pedal. Lift the floor plate.
2. Install the weight carrier (E, Figure 46), mount plates (B & C) and fasten with the 3/8-16 x 3" bolts (A) and 3/8-16 nylon lock nuts (D). Tighten securely.
3. Install the counter weights (H) in the weight carrier and secure with the retaining pin (F) and hair pin clips (G).
4. Lower floor plate and reinstall deck lift foot pedal, clevis pin and hair pin clip.

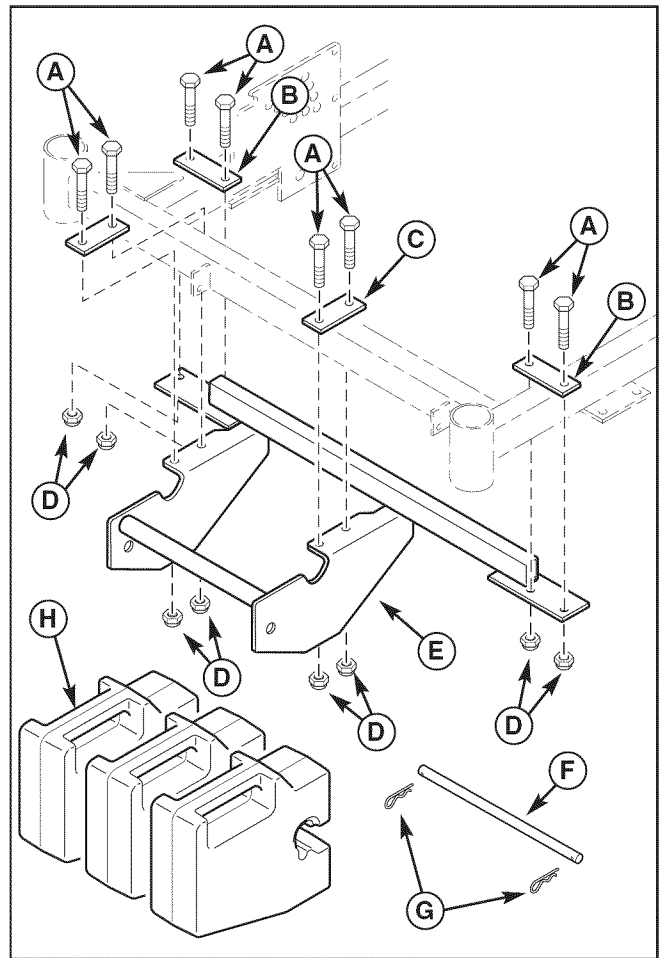

Figure 46. Install Weight Carrier

- A. 3/8-16 x 3" Bolts
- B. Mount Plate
- C. Mount Plate
- D. 3/8-16 Nylon Lock Nuts
- E. Weight Carrier
- F. Retaining Pin
- G. Hairpin Clip
- H. Weight

Weight Mount Installation

(IS1000Z Series)

Install Weight Carriers

1. Install the left-hand and right-hand weight carriers (E & H, Figure 47), bar clamps (F) and fasten with the 5/16-18 x 2-1/2" bolts (B) and 5/16-18 nylon lock nuts (G). Make sure carriers are tight against the outside of the suspension arm and do not interfere with the shock/spring assembly. Tighten securely.
2. Install the counter weights (A) in the weight carrier and secure with the clevis pins (D) and hair pin clips (C).

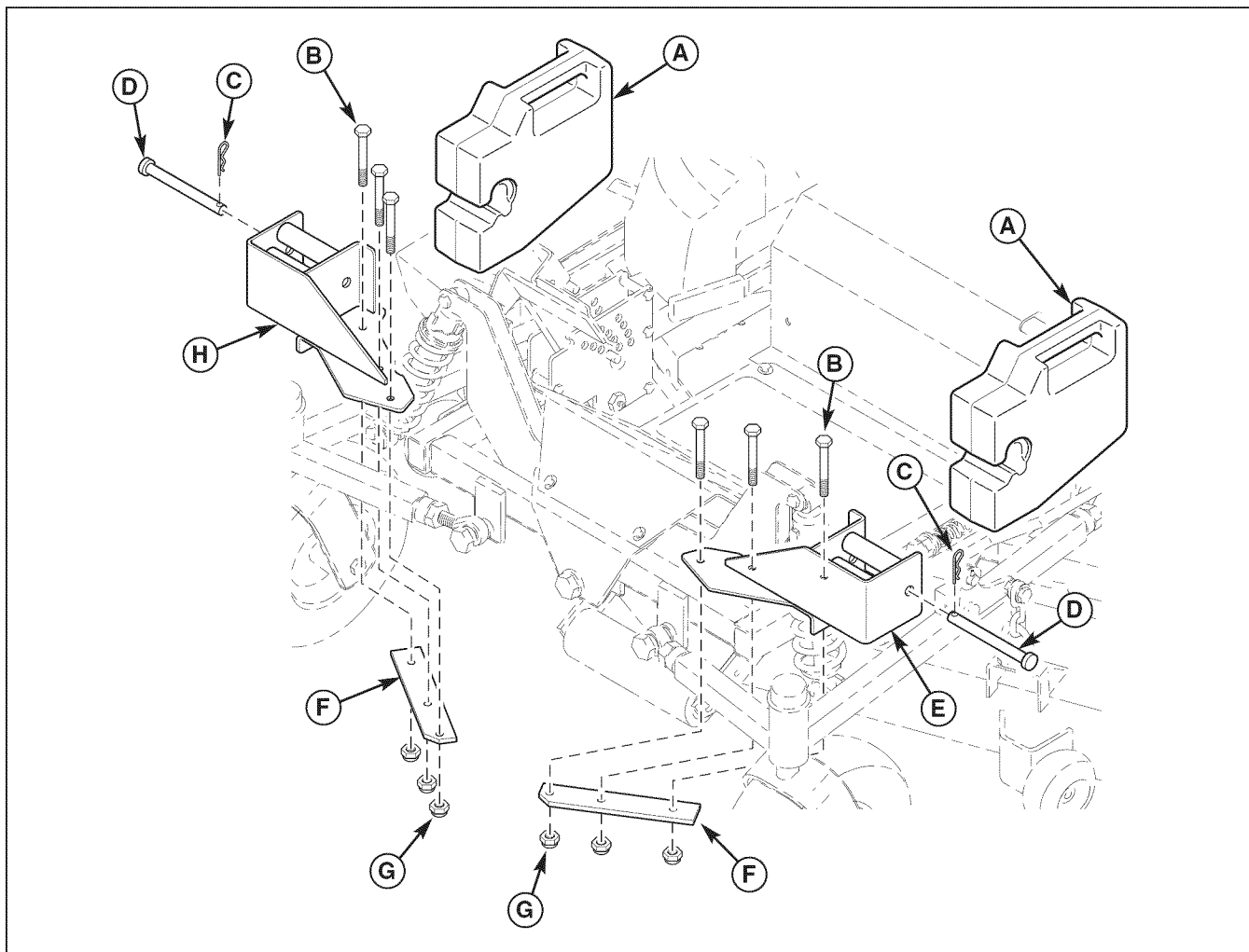

Figure 47. Install Weight Carriers

- A. Weight
- B. 5/16-18 x 2-1/2 Bolt
- C. Hairpin Clip
- D. Clevis Pin
- E. Weight Carrier-LH
- F. Bar Clamp
- G. 5/16-18 Nylon Lock Nuts
- H. Weight Carrier-RH

Install Weight Mount Rack

1. Measure and mark the front main frame tubes to the dimensions shown in Figure 48.
2. Using a 3/8" drill bit, drill one (1) hole in each of the main frame tubes from the outside surface of the tube.

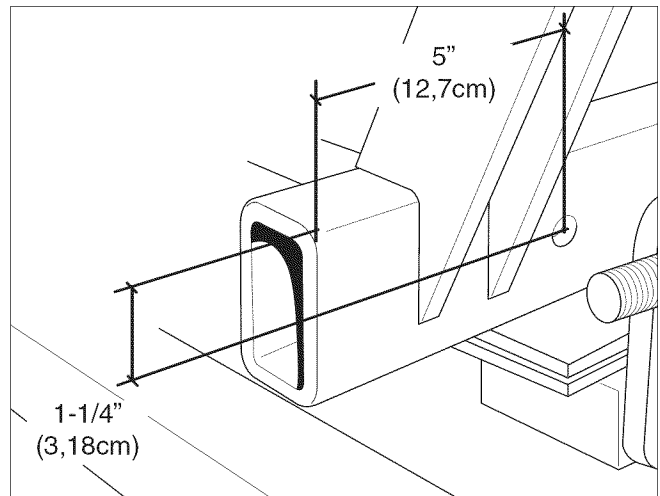

Figure 48. Hole Location

3. Slide the weight mount rack into the main frame tubes and align with the holes drilled through the frame (see Figure 49). It may require you drive the arms into the frame tubes using a wooden block and hammer.
4. Finish drilling through the opposite wall of the frame tubes using the weight rack as a guide.
5. Install the 3/8" bolts from the inside of the frame rail and fasten securely with the nylon lock nuts.

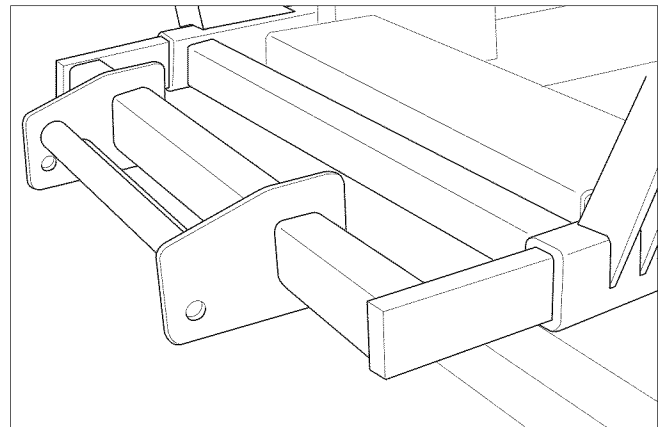

Figure 49. Weight Rack Installation

6. Install the counter weights supplied with the grass collector on the weight mount rack (see Figure 50).
7. Install the weight retainer rod through the weight mount rack and secure with the hairpin clips (see Figure 50).

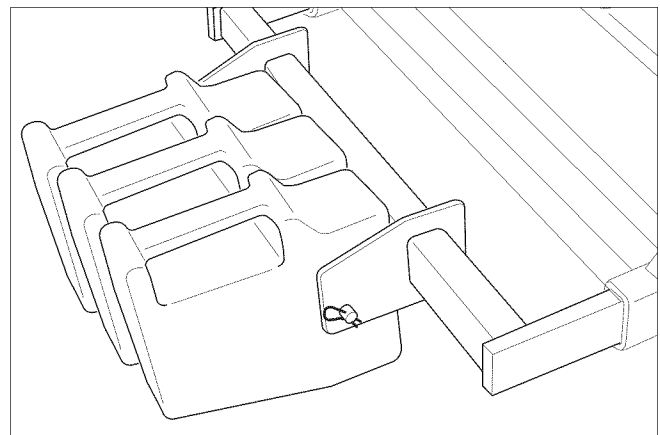

Figure 50. Weight & Retainer Rod Installation

Weight Mount Installation

(IS500Z & IS1500Z Series)

Install Weight Carrier

1. Install the weight carrier (A, Figure 51) onto the front of the unit and secure with the 1/2-20 x 1-1/4" bolts (B), 1/2" washers (C) and 1/2-20 nylon lock nuts (D).

NOTE: Use outer holes in the weight carrier for the IS1500Z Series (shown) and the inner holes for the IS4500Z Series.

2. Install the counter weights (E) in the weight carrier and secure with the retaining pin (F) and hairpin clips (G).

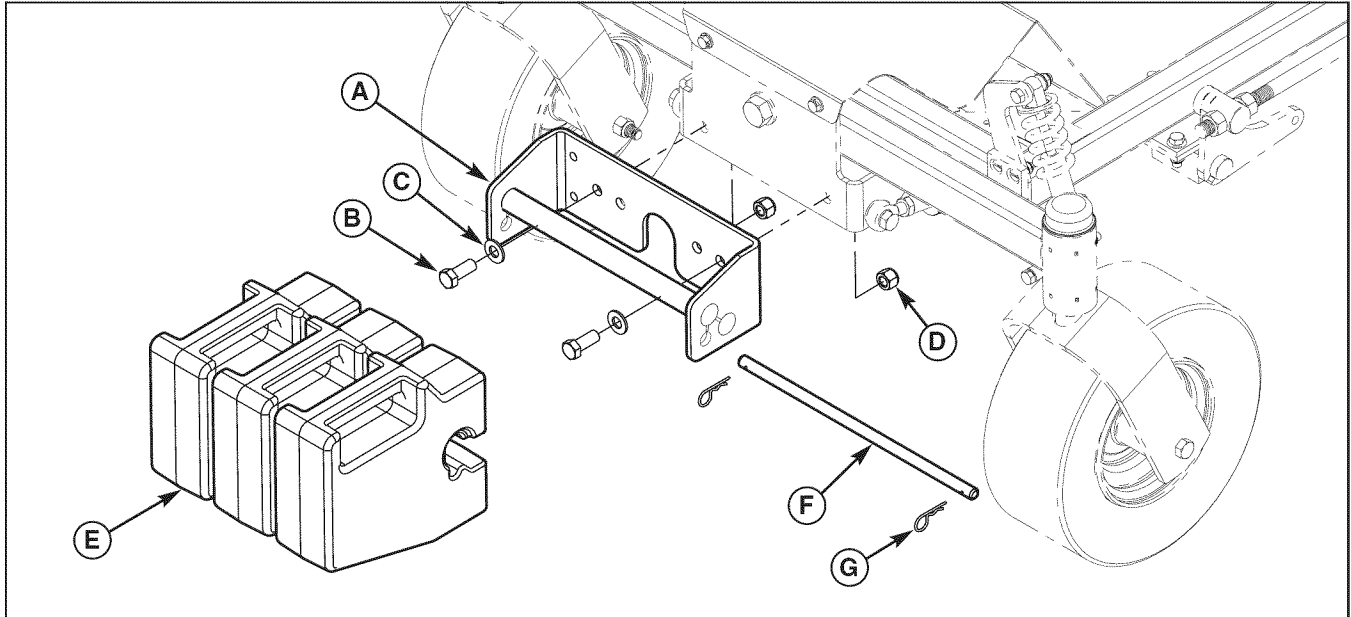

Figure 51. Install Weight Carrier

- A. Weight Carrier
- B. 1/2-20 x 1-1/4" Bolt
- C. 1/2" SAE Washer
- D. 1/2-20 Nylon Lock Nut
- E. Weight
- F. Retaining Pin
- G. Hairpin Clip

Install Weight Carrier

1. Install the weight carrier (A, Figure 52) onto the front of the unit and secure with the 3/8-16 x 1-1/4" bolts (C), 3/8" washers (B) and 3/8-16" nylock flange nuts (G).

NOTE: Use top holes in the weight carrier for the IS2000Z Series (as shown in Figure 52).

2. Install the counter weights (D) in the weight carrier and secure with the retaining pin (E) and hairpin clips (F).

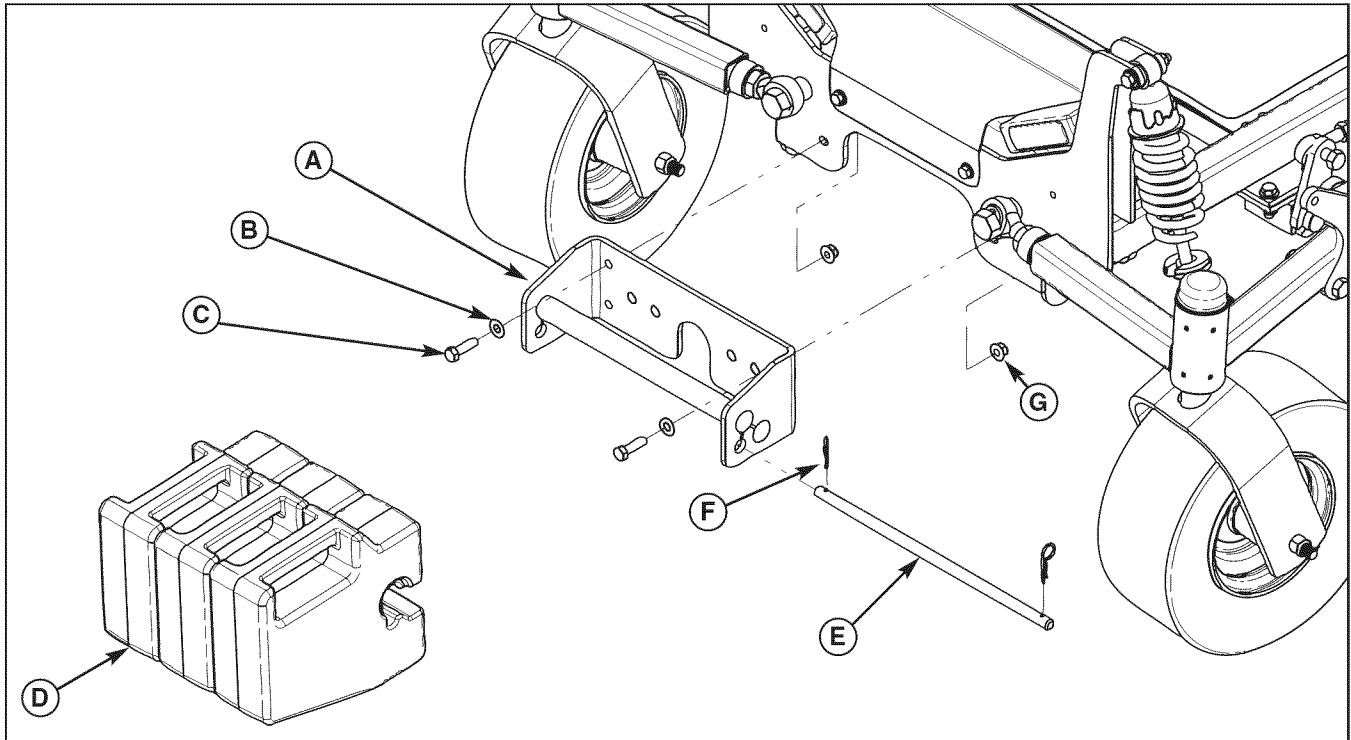

Figure 52. Install Weight Carrier

- A. Weight Carrier
- B. 3/8" SAE Washer
- C. 3/8-16X1-1/4" Bolt
- D. Weight
- E. Retaining Pin
- F. Hairpin Clip
- G. 3/8-16 Nylock Flange Nut

Weight Mount Installation

(IS4500Z Series)

Install Weight Carrier

1. Support the front of the frame in the center of the unit with a jackstand.
2. Remove the 1/2-13 x 5" bolts (B, Figure 53) and 1/2-13 nylon lock nuts (C) securing the front suspension arms to the frame.
3. Install the weight carrier (A) onto the front of the unit and secure with the 1/2-13 x 5" bolts and 1/2-13 nylon lock nuts previously removed.
4. Install the counter weights (D) in the weight carrier and secure with the retaining pin (E) and hairpin clips (F).

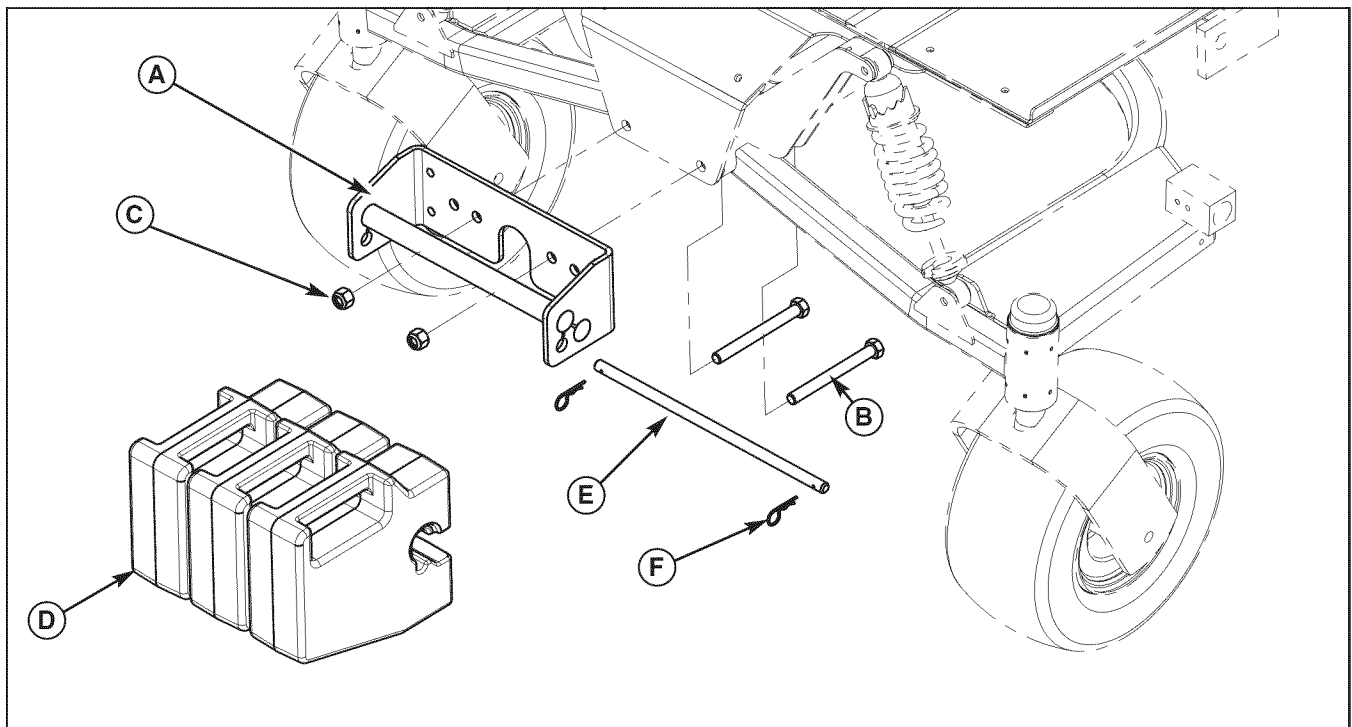

Figure 53. Install Weight Carrier

- A. Weight Carrier
- B. 1/2-13 x 5" Bolt
- C. 1/2-13 Nylon Lock Nut
- D. Weight
- E. Retaining Pin
- F. Hairpin Clip

Install Weight Carrier

1. Install the weight carrier (A, Figure 54) onto the front of the unit and secure with the 3/8-16 x 1-1/4" bolts (C), 3/8" washers (B) and 3/8-16" nylock flange nuts (G).

NOTE: Use top holes in the weight carrier for the IS2000Z Series (as shown in Figure 54).

2. Install the counter weights (D) in the weight carrier and secure with the retaining pin (E) and hairpin clips (F).

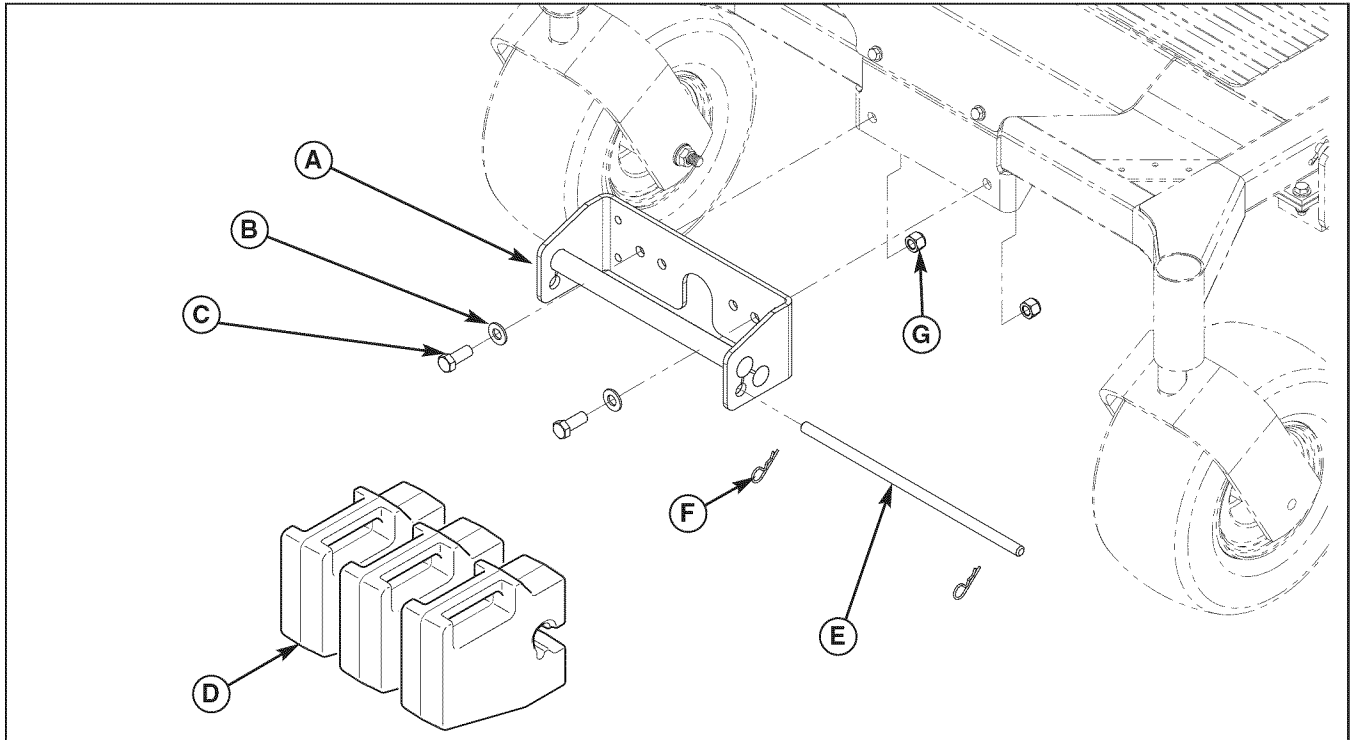

Figure 54. Install Weight Carrier

- A. Weight Carrier
- B. 3/8" SAE Washer
- C. 3/8-16X1-1/4" Bolt
- D. Weight
- E. Retaining Pin
- F. Hairpin Clip
- G. 3/8-16 Nylock Flange Nut

Blower & Collector Removal

1. Remove the knobs (A, Figure 55) securing the deck guard top (B) to the deck guard.
2. Pull the blower idler arm lever (C) forward to release the belt tension and remove the belt from the spindle pulley.
3. Reinstall the deck guard top and secure with the knobs.

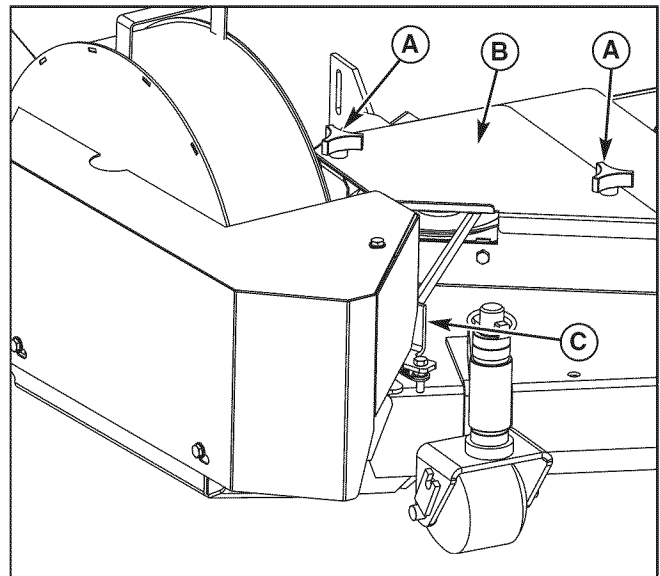

Figure 55. Remove the Belt

- A. Knob
- B. Deck Guard Top
- C. Idler Arm Lever

4. Loosen the lower clamp securing the hose to the blower outlet and remove the hose from the blower. See Figure 56.
5. Pull the quick pins on the blower mount and remove the blower from the mower deck.

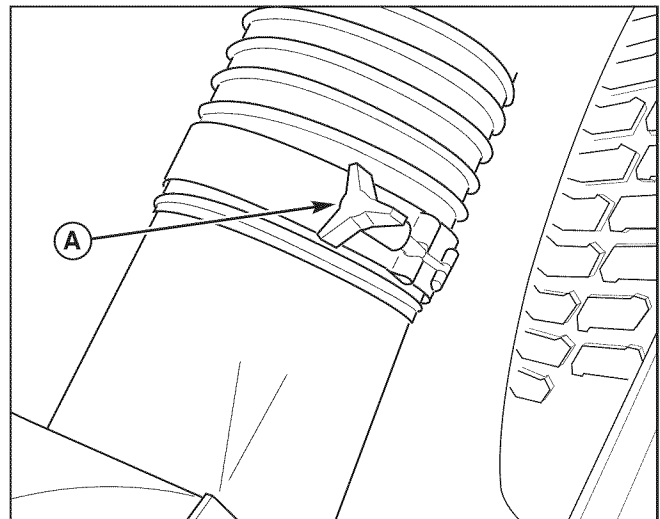

Figure 56. Remove the Hose

- A. Lower Clamp (with knob)

6. Reinstall the discharge chute (A, Figure 57) and secure with the supplied quick attach rod (B) and hairpin clips (C).
7. Empty the grass collector bags and reinstall in the bagger frame.

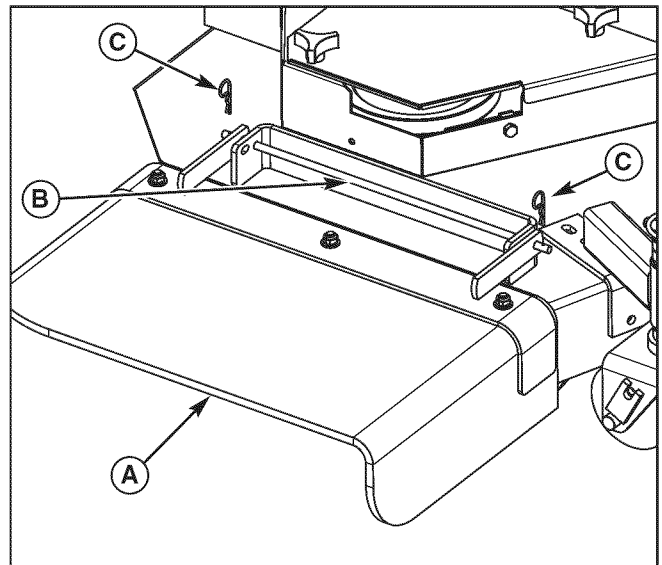

Figure 57. Reinstall the Discharge Chute

- A. Discharge Chute
- B. Quick Attach Rod
- C. Hairpin Clip

8. Remove the hitch pins (B, Figure 58) securing the bagger mount posts (A) to the mount plate.
9. Lift the bagger unit up and off of the mount plate.

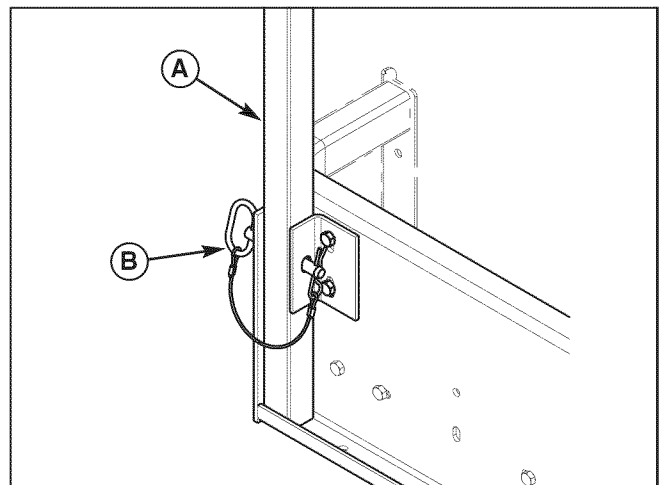



Figure 58. Remove the Hitch Pins

- A. Mount Post
- B. Hitch Pin



Lea estas reglas de seguridad y sígalas con cuidado. Hacer caso omiso de ellas puede ocasionar la pérdida del control sobre la unidad, lesiones corporales graves o la muerte a usted o a los espectadores, o daños a la propiedad o al equipo.

Esta cubierta de la podadora puede amputar manos y pies y arrojar objetos.

El triángulo  en el texto denota precauciones o advertencias importantes que deben tomarse en cuenta.

ADVERTENCIAS GENERALES

- Conozca los controles de la podadora, las reglas de seguridad y cómo detenerla rápidamente. **LEA Y COMPRENDA EL MANUAL DEL OPERADOR DE LA PODADORA.**
- Lea y obedezca todas las calcomanías de seguridad.
- Use la protección adecuada para oídos, ojos y respiración.
- Sólo permita que un adulto responsable, que esté familiarizado con las instrucciones, opere la unidad.
- Desactive el embrague eléctrico (PTO). Apague el motor y permita que se detengan todas las piezas móviles antes de anexar, ajustar o desconectar alguna parte del sistema de recepción.
- Compruebe que el sistema de recepción esté fijamente atornillado al montable.
- NO opere la podadora si no está el receptor de pasto completo o el deflector en su lugar.
- Apague el interruptor PTO para desactivar las cuchillas cuando no esté podando el pasto.
- NO pode el pasto en reversa. Mire siempre hacia abajo y hacia atrás antes de echarse en reversa y mientras lo hace.
- NO gire bruscamente cuando conduzca en reversa junto a un edificio o algún objeto. Reduzca la velocidad antes de girar.
- NO lleve pasajeros en el montable.
- Cuando se quita el conjunto de soplador de la cubierta de la podadora, debe instalar debidamente el deflector.
- Las bolsas recolectoras son susceptibles de deterioro y desgaste durante el uso normal. Inspeccione la bolsa periódicamente para comprobar que no tenga rasgaduras, agujeros o puntos débiles y reemplácela con una bolsa nueva, que cumpla con las normas de durabilidad del fabricante.
- Si se atasca la podadora o se obstruye la tolva del soplador turbo:
 1. Desactive el embrague eléctrico (PTO);
 2. Detenga el motor y quite la llave;
 3. Ponga el freno de mano y espere a que se detengan todas las piezas móviles.
 4. Quite el objeto extraño o limpie la tolva con un pedazo de madera antes arrancar nuevamente el motor. **NUNCA ponga las manos en la caja del soplador para quitar un objeto atascado. El soplador puede girar al quitar el objeto.**
- Para dar mayor estabilidad al montable y evitar que se vuelque o que pierda el control sobre él:
 - a. Reduzca la velocidad en terrenos desnivelados y al girar en las esquinas.
 - b. Reduzca la carga en las laderas. Se recomienda que llene el sistema de recepción sólo a la mitad cuando franquea una pendiente. Empiece a podar el pasto en la pendiente con el sistema de recepción vacío.
 - c. Pode el pasto de la pendiente de un lado a otro, pero no hacia arriba o abajo.
- **Nunca opere en pendientes con una inclinación superior a 17.6% (10°).**

CALCOMANÍAS DE SEGURIDAD

Esta unidad fue diseñada y fabricada para brindarle seguridad y confiabilidad, características que usted esperaría de un líder en la industria de la fabricación de equipos motorizados para el exterior.

Aunque leer este manual, y las medidas de seguridad que contiene, le proporcionará el conocimiento básico necesario para operar este equipo sin percances y de modo eficaz, hemos colocado varias etiquetas de seguridad en la unidad para recordarle esta importante información mientras usted la opera.

Debe leer cuidadosamente y obedecer todos los mensajes de PELIGRO, ADVERTENCIA,

PRECAUCIÓN y las instrucciones en su podadora y su montable. Hacer caso omiso de las instrucciones puede ocasionar lesiones corporales. La información es para su seguridad y es importante. Las calcomanías de seguridad que presentamos abajo están pegadas en su podadora y en su montable.

Si pierde o se daña alguna de estas calcomanías, reemplácela inmediatamente. Busque a su distribuidor local para reponerlas.

Estas etiquetas son fáciles de pegar y servirán como constantes recordatorios visuales para usted, y otros que puedan llegar a usar el equipo, para que sigan las medidas de seguridad necesarias para una operación eficaz y sin percances.

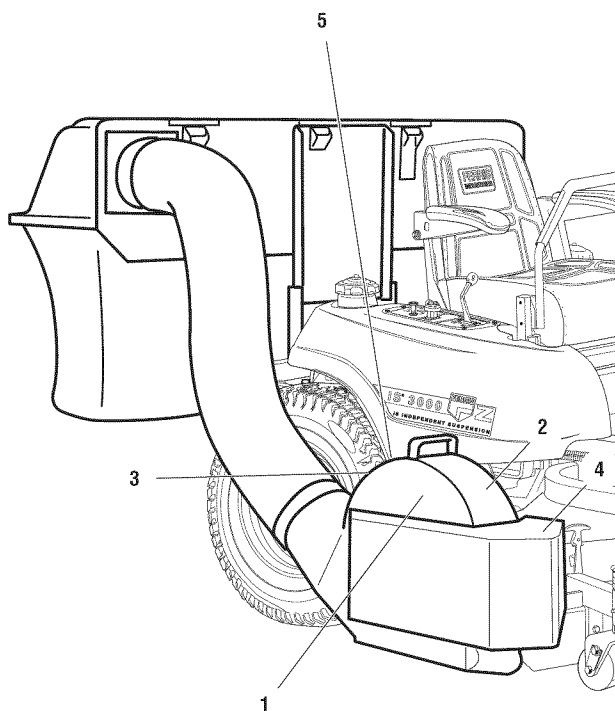

1 — **FAST-Vac**

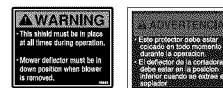
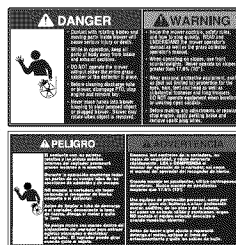

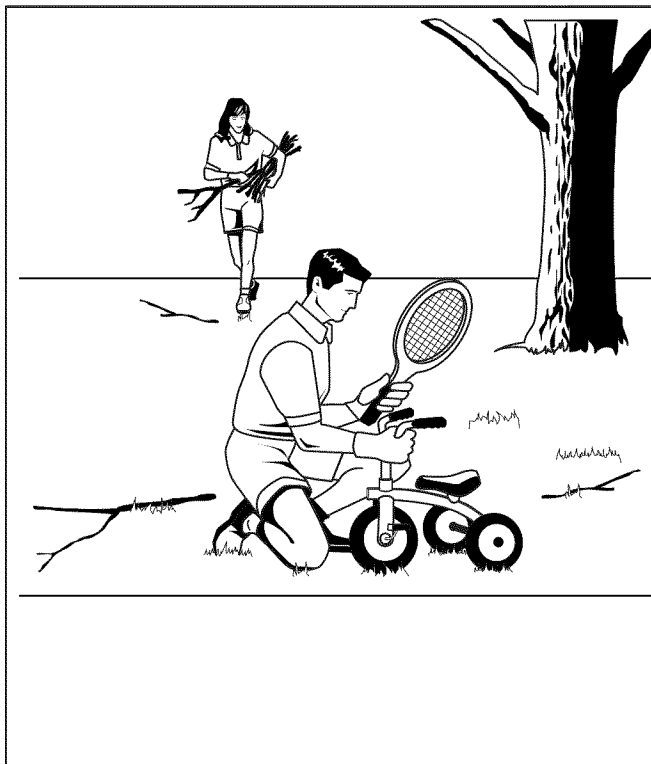

ANTES DE LA OPERACIÓN

Despeje el jardín de las ramas, piedras, alambres y otros despojos que puedan quedar atrapados en las cuchillas de la podadora o que puedan ser lanzados por las mismas.

Revise la condición del pasto. Si está húmedo, espere hasta más tarde durante el día. Si el pasto está húmedo, es probable que se obstruya el receptor de pasto.

Para que la recepción del pasto en la bolsa sea eficiente, es muy importante la circulación de aire debajo de la cubierta de la podadora, a través de la tolva y hacia la bolsa.

Por eso, ANTES DE EMPEZAR A PODAR asegúrese de que la parte inferior de la podadora y de la tapa del receptor estén exentos de pasto o despojos.

Asegúrese que la cubierta de la podadora, la caja del soplador, los tubos y la tapa del receptor de pasto estén debidamente ajustados.

PODAR CON EL RECEPTOR DOBLE O TRIPLE

Opere siempre con el acelerador en velocidad máxima cuando pade el pasto.

Use siempre protectores para oídos cuando opere el receptor de pasto.

Debe poder el pasto con frecuencia y no dejarlo demasiado corto. Si el pasto es demasiado largo o abundante, quizá sea necesario mantener la velocidad de avance al mínimo o cortar sólo la mitad del ancho de la podadora para evitar que se obstruya. Si el pasto está muy largo, opere la podadora en la posición de corte más alta en la primera pasada, y córtelo de nuevo en la posición más baja en la segunda pasada.

No abra la cubierta mientras la podadora está activada

Si sale una gran cantidad de pasto cortado por debajo de la cubierta, es posible que esté obstruido el tubo o que las bolsas estén llenas: interrumpa la actividad, detenga el montable, desactive el PTO y vacíe el receptor o despeje el tubo

⚠️ ADVERTENCIA

Apague SIEMPRE el tractor, desactive el PTO y permita que se detengan las piezas móviles ANTES de desconectar o despejar el tubo o de vaciar el receptor.

Antes de dejar el puesto del operador por el motivo que sea, accione el freno de mano, desactive el PTO, detenga el motor y quite la llave.

Para reducir el peligro de un incendio, mantenga el motor, el montable y la podadora libre de pasto, hojas y aceite excesivo. No detenga ni estacione el montable sobre hojas secas, pasto o materiales combustibles.

⚠️ PRECAUCIÓN



Esta máquina produce niveles de sonido por encima de 85 dBA cerca del oído del operador y pueden originar la pérdida auditiva cuando se expone al ruido por períodos prolongados. Protéjase siempre los oídos al operar esta máquina.

DESPUÉS DE LA OPERACIÓN

Quite cualquier despojo de la pantalla en la parte inferior de la tapa. Nota: puede quitar parcialmente la pantalla de la tapa para limpiarla con mayor facilidad y debe hacerlo con regularidad.

Debe quitar la caja del soplador y el tubo para limpiarlos.

Inspeccione las bolsas de pasto para ver si presentan desgaste o daños. Asegúrese que la cubierta de la podadora, la caja del soplador, los tubos y la tapa del receptor de pasto estén debidamente ajustados.

ALMACENAR EL RECEPTOR DE PASTO

Limpie a fondo el receptor de pasto usando un detergente suave (otros productos pueden dañar el tubo). Quite cualquier despojo de la pantalla en la parte inferior de la tapa. Puede quitar parcialmente la pantalla para limpiar con mayor facilidad.

Si la pintura en las piezas metálicas está rayada, retoque con pintura o aplique una capa delgada de aceite para evitar la corrosión.

Almacénese en una zona seca. Cuelgue el receptor y las bolsas para que se sequen totalmente antes de almacenarlos por un período largo de tiempo.

Almacene las piezas en un lugar sin humedad.

PODAR SIN EL SOPLADOR

Para operar la podadora sin el soplador, instale debidamente el deflector apuntando hacia abajo.

Para quitar el soplador, invierta los pasos de la instalación.

Remoción del soplador y receptor

1. Quite las perillas (A, Figura 59) y fije la parte superior de la guarda de la cubierta (B) a la guarda misma.
2. Jale hacia adelante la palanca del brazo tensor del soplador (C) para liberar la tensión de la correa y retirar la correa de la polea del huso.
3. Instale nuevamente la parte superior de la guarda de la cubierta y fíjela con las perillas.



Figura 59. Remoción de la correa

- A. Perilla
- B. Parte superior de la guarda de la cubierta
- C. Palanca del brazo tensor

4. Afloje la abrazadera inferior que sujeta la manguera a la conexión de salida del soplador y quite la manguera del soplador. Vea la Figura 60..
5. Jale los pasadores de desenganche en el soplador y quite el soplador de la cubierta de la podadora.

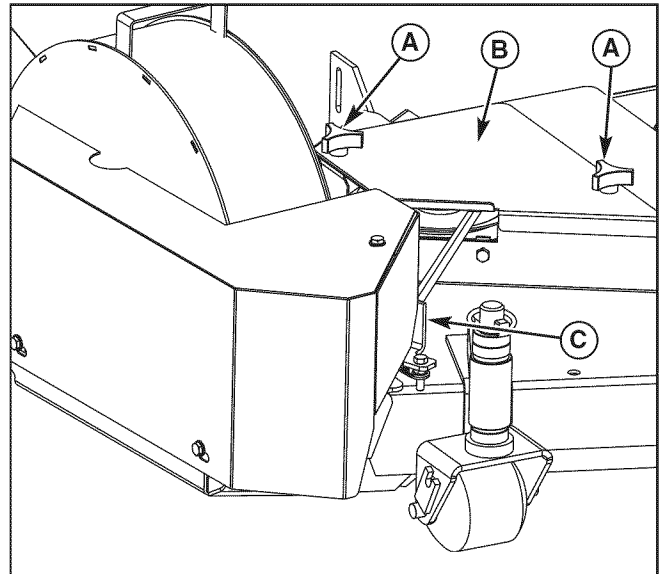

Figura 60. Remoción de la manguera

- A. Abrazadera inferior

6. Instale nuevamente la tolva de expulsión (A, Figura 61) y sujétela con el brazo de sujeción rápida (B) y los pasadores de horquilla (C), incluidos.
7. Vacíe las bolsas del receptor de pasto e instálelas nuevamente en la estructura.

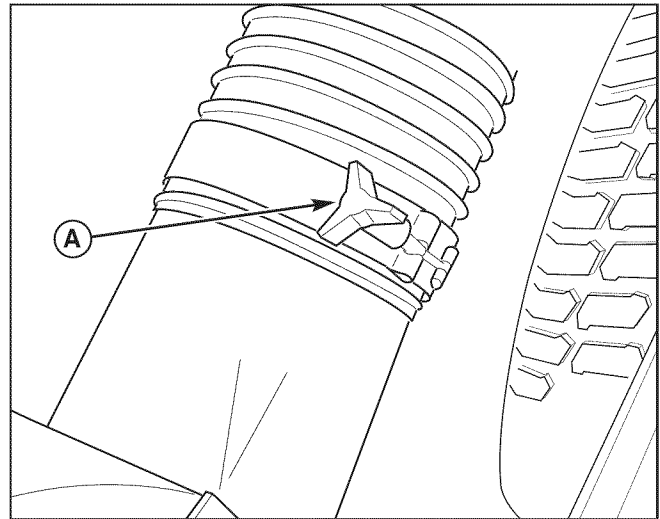

Figura 61. Nueva instalación de la tolva de expulsión

- A. Tolva de expulsión
- B. Brazo de sujeción rápida
- C. Pasador de horquilla

8. Quite los pasadores de enganche (B, Figura 62) fijando los postes de soporte de las bolsas (A) a la placa de soporte.
9. Levante la unidad con la bolsa hasta que deje de entrar en contacto con la placa de soporte.

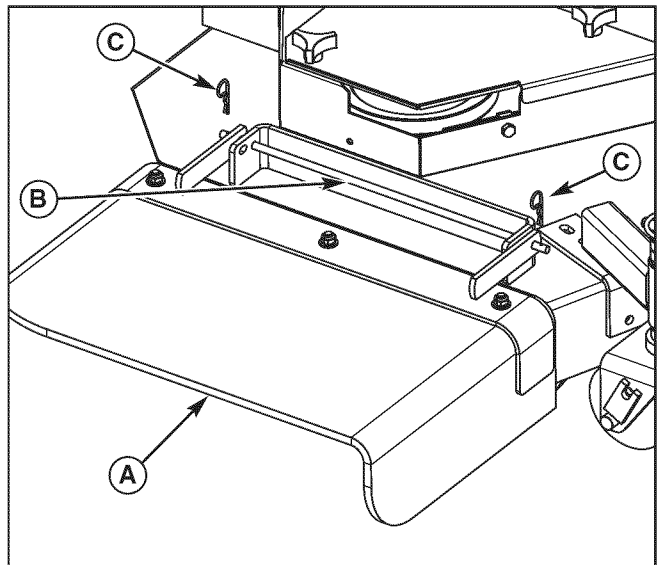

Figura 62. Remoción de los pasadores de enganche

- A. Poste de soporte
- B. Pasador de enganche

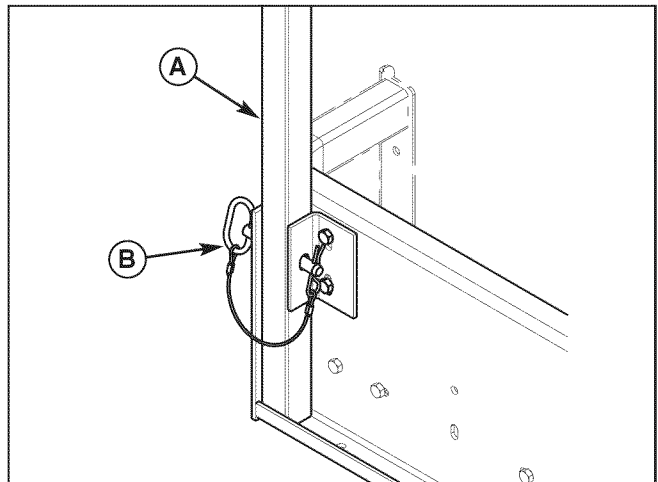
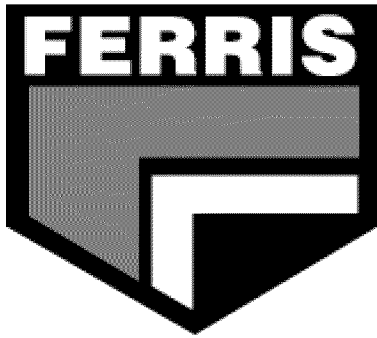

FAST-Vac

Grass Collection Systems

Briggs & Stratton Yard Power Products Group
5375 North Main Street
Munnsville, NY 13409
800-933-6175
www.ferrisindustries.com