

✓ TFX24EFB

# How to get the best from **Your Refrigerator**

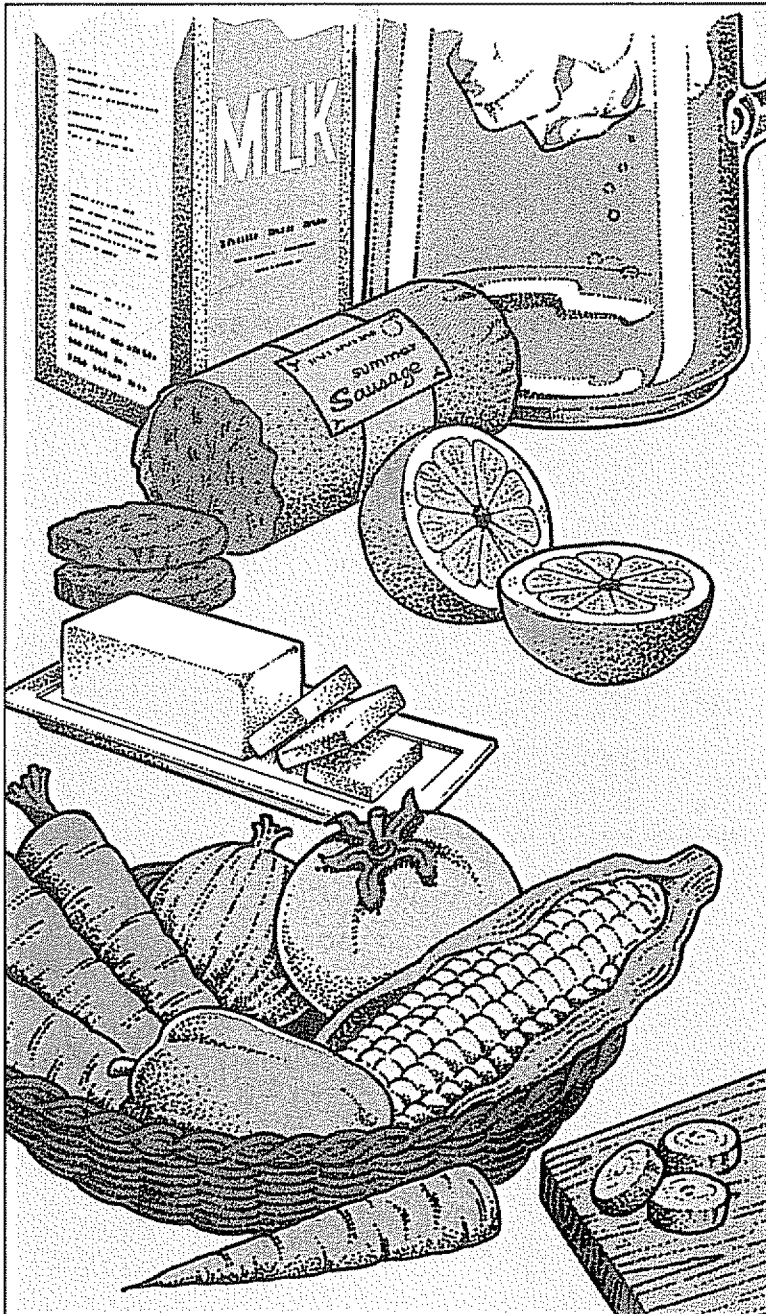

Use and Care of  
Model TFX24E with  
Custom Ice & Chilled  
Water Dispenser

Electronic Monitor and  
Diagnostic System p6

How to Use Your  
Dispenser Controls p10

Food Storage Suggestions p13

Save time and money.  
Before you request service,  
use the Problem Solver. p19



Your Direct Line to General Electric  
The GE Answer Center® 800.626.2000

# Contents

	Page
Energy-Saving Tips . . . . .	2
Important Safety Instructions . . .	3
How to Connect Electricity . . .	3, 4
Installation Requirements . . . . .	4
How to Adjust Rollers . . . . .	4
How to Set Temperature Controls . . . . .	5
Automatic Energy Saver System . . . . .	5
Electronic Monitor and Diagnostic System . . . . .	6-9
Automatic Icemaker and Water & Ice Dispenser . . . . .	10-12
Food Storage Suggestions . . . . .	13
Food-Saver System . . . . .	14
Shelf Positions . . . . .	15, 16
User Maintenance Instructions . . . . .	17, 18
Water Filter Accessory . . . . .	18
Problem Solver . . . . .	19-22
Consumer Services . . . . .	23
Warranty . . . . .	Back Cover

## Help us help you...

### Read this book carefully.

It is designed to help you operate and maintain your new refrigerator properly.

Keep it handy for answers to your questions

If you don't understand something or need more help

Call, toll-free:

The GE Answer Center™  
800 626 2000

consumer information service

or write (include your phone number)

Consumer Affairs  
General Electric Company  
Appliance Park  
Louisville, KY 40225

### Write down the model and serial numbers.

You'll find them on a label at the bottom, just inside the fresh food compartment door.

These numbers are also on the Consumer Product Ownership Registration card that came with your refrigerator. Before sending in this card, please write these numbers here:

---

Model Number

---

Serial Number

Use these numbers in any correspondence or service calls concerning your refrigerator.

**If you received a damaged refrigerator**, immediately contact the dealer (or builder) that sold you the refrigerator

### Save time and money.

**Before you request service**, check the Problem Solver on pages 19 through 22. It lists minor causes of operating problems that you can correct yourself.

## Energy-Saving Tips

- Location of your refrigerator is important. Avoid locating it next to your range, a heating vent or where sun will shine directly on it.
- Don't open doors more often than necessary.
- Close the doors as soon as possible, particularly in hot, humid weather.
- Be sure the doors are closed tightly. Before leaving the house or retiring for the night, check to be sure the doors haven't been left open accidentally.
- Store only those foods requiring refrigeration in your refrigerator.
- Wipe all moisture from bottles and cartons before putting them in the refrigerator.
- Keep all foods covered to reduce moisture build-up inside the refrigerator.
- If you turn controls to coldest position for quick chilling or freezing, be sure to turn them back to regular settings.
- Don't overcrowd your refrigerator. Overcrowding can require extra electrical energy to keep everything cool.

# Important Safety Instructions

Read all instructions before using this appliance.

**WARNING**—When using this appliance, always exercise basic safety precautions, including the following:

- Use this appliance only for its intended purpose as described in this Use and Care Book.
- This refrigerator must be properly installed in accordance with the Installation Instructions before it is used. See grounding instructions below and on page 4.
- Never unplug your refrigerator by pulling on the power cord. Always grip plug firmly and pull straight out from the receptacle.
- Repair or replace immediately all electric service cords that have become frayed or otherwise damaged. Do not use a cord that shows cracks or abrasion damage along its length or at either the plug or connector end.
- When moving your refrigerator away from the wall, be careful not to roll over or damage the power cord.
- After your refrigerator is in operation, do not touch the cold surfaces, particularly when hands

are damp or wet. Skin may adhere to these extremely cold surfaces.

- Do not place fingers or hands on the automatic icemaking mechanism while the refrigerator is plugged in. This will prevent contact with the moving parts of the ejector mechanism, or with the heating element that releases the cubes
- Don't refreeze frozen foods which have thawed completely. The United States Department of Agriculture in Home and Garden Bulletin No. 69 says:  
 "... You may safely refreeze frozen foods that have thawed if they still contain ice crystals or if they are still cold—below 40°F  
 "... Thawed ground meats, poultry, or fish that have any off-odor or off-color should not be refrozen and should not be eaten. Thawed ice cream should be discarded. If the odor or color of any food is poor or questionable, get rid of it. The food may be dangerous to eat.  
 "Even partial thawing and refreezing reduce the eating quality of foods, particularly fruits, vegetables and prepared foods. The eating quality of red meats is affected less than that of many

other foods. Use refrozen foods as soon as possible to save as much of their eating quality as you can."

- If your old refrigerator is still around the house but not in use, be sure to remove the doors. This will reduce the possibility of danger to children.
- Unplug your refrigerator:
  - A. Before making any repairs  
 Note: We strongly recommend that any servicing be performed by a qualified individual.
  - B. Before cleaning.
  - C. Before replacing a burned-out light bulb, the refrigerator should be unplugged in order to avoid contact with a live wire filament (A burned-out light bulb may break when being replaced.)  
 Note: Turning control to OFF position does not remove power to the light circuit.
- Do not operate your refrigerator in the presence of explosive fumes.

## SAVE THESE INSTRUCTIONS

## Installation Requirements — IMPORTANT... Please Read Carefully

### How to connect electricity

For personal safety, this appliance must be properly grounded.

The power cord of this appliance is equipped with a three-prong (grounding) plug which mates with a standard three-prong (grounding) wall receptacle (Fig 1) to minimize the possibility of electric shock hazard from this appliance

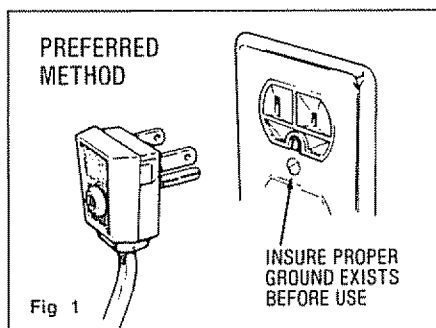

Have the wall receptacle and circuit checked by a qualified electrician to make sure the receptacle is properly grounded

Where a standard two-prong wall receptacle is encountered, it is the personal responsibility and obligation of the customer to have it replaced with a properly grounded three-prong wall receptacle

**DO NOT, UNDER ANY CIRCUMSTANCES, CUT OR REMOVE THE THIRD (GROUND) PRONG FROM THE POWER CORD.**

(continued next page)

# Installation Requirements (continued) – IMPORTANT... Please Read Carefully

## Use of adapter plug

Because of potential safety hazards under certain conditions, we strongly recommend against use of an adapter plug. However, if you still elect to use an adapter, where local codes permit, a **TEMPORARY CONNECTION** may be made to a properly grounded two-prong wall receptacle by use of a UL listed adapter (Fig. 2) available at most local hardware stores.

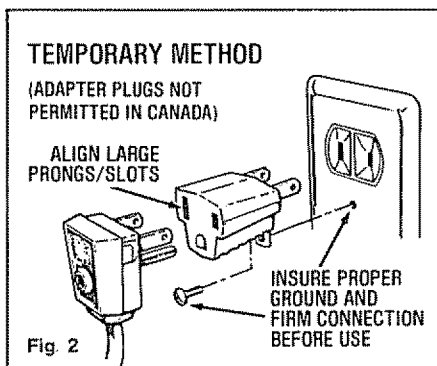

The larger slot in the adapter must be aligned with the larger slot in the wall receptacle to provide proper polarity in the connection of the power cord.

**CAUTION:** Attaching adapter ground terminal to wall receptacle cover screw does not ground the appliance unless cover screw is metal, and not insulated, and wall receptacle is grounded through house wiring. Customer should have the circuit checked by a qualified electrician to make sure the receptacle is properly grounded.

**When disconnecting the power cord from the adapter,** always hold the adapter with one hand. If this is not done, the adapter ground terminal is very likely to break with repeated use.

**Should the adapter ground terminal break, DO NOT USE the appliance until a proper ground has again been established.**

## Use of extension cords

Because of potential safety hazards under certain conditions, we strongly recommend against the use of an extension cord. However, if you still elect to use an extension cord, it is absolutely necessary that it be a UL listed 3-wire grounding type appliance extension cord having a grounding type plug and outlet and that the electrical rating of the cord be 15 amperes (minimum) and 120 volts. Such extension cords are obtainable through your local service organization.

## The refrigerator should always be plugged into its own individual electrical outlet—

(115 volt, 60 Hertz, single phase AC) This is recommended for best performance and to prevent overloading house wiring circuits, which could cause a possible fire hazard from overheating wires.

## Refrigerator Installation

### Location

**Do not install refrigerator where temperature will go below 60°F.** because it will not run often enough to maintain proper temperatures

**Do install it on a floor strong enough to support a fully loaded refrigerator.**

Also see Energy-Saving Tips regarding location

### Clearances

**Allow 5/8" at each side, 1" over top, and 1" at rear for ease of installation, proper air circulation, plumbing and electrical connections. Allow 3/4" at each side for door clearance.**

### Water Supply

There should be sufficient tubing for the icemaker from the cold water supply to allow you to move the refrigerator out from the wall several feet (approximately 3 coils of 1/4-inch copper tubing that measure at least 10 inches in diameter).

## Rollers

**Adjustable rollers,** which enable you to move your refrigerator away from the wall for cleaning, are located behind the base grille.

These rollers should be set so that the refrigerator is firmly positioned on the floor and the front is raised just enough that the doors close easily when opened about halfway. Specially designed door hinges lift both doors slightly when opened. The force of gravity then helps close the doors automatically.

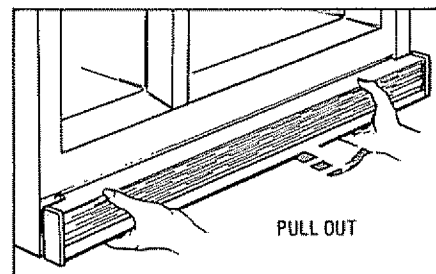

**To adjust rollers,** remove the base grille by grasping it at the bottom and pulling it out.

**Turn roller adjusting screws** clockwise to raise refrigerator, counterclockwise to lower it. Use adjustable wrench (3/8" hex head bolt) or pliers.

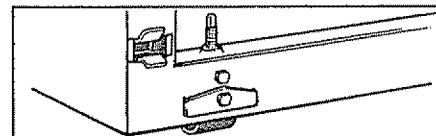

When adjusting front rollers for proper door closure, it is recommended that the bottom front edge of the cabinet be approximately 5/8 inch from the floor.

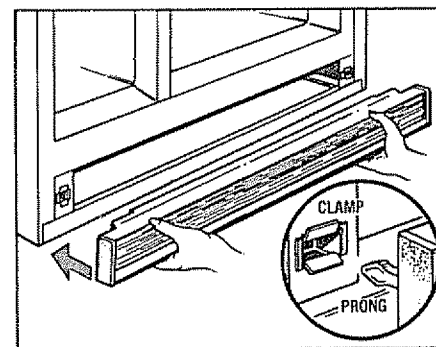

**To replace base grille,** align prongs on back of grille with clamps in cabinet and push forward until grille snaps into place.

# Operating Your Refrigerator

## Set the temperature controls

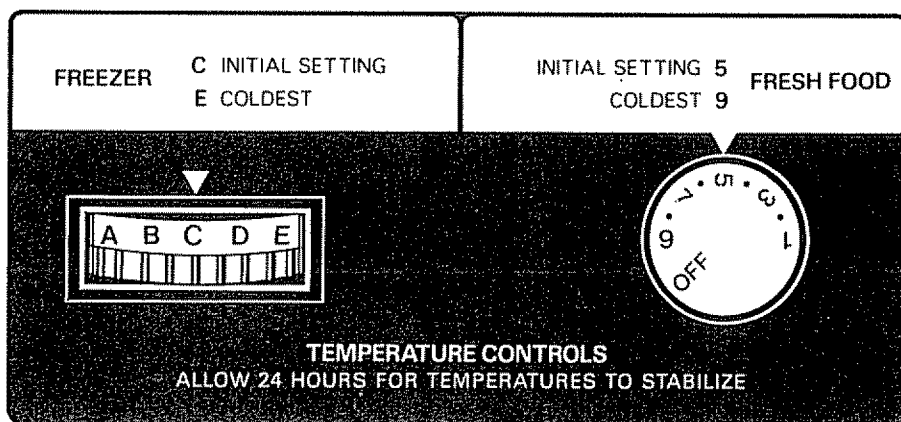

Your refrigerator has two controls that let you regulate the temperature in the fresh food and freezer compartments.

**INITIALLY**, set the **FRESH FOOD** control at 5 and the **FREEZER** control at C.

For colder or warmer temperatures, adjust the desired compartment control one letter or number at a time.

### IMPORTANT

When initially setting the controls or when adjusting them, allow 24 hours for the temperatures to stabilize, or even out.

**Note:** Turning the fresh food control to "OFF" turns off **BOTH** compartments—fresh food **AND** freezer.

### How to test temperatures

**Use the milk test for the fresh food compartment.** Place a container of milk on the top shelf in the fresh food compartment. Check it a day later. If the milk is too warm or too cold, adjust the temperature controls.

**Use the ice cream test for the freezer compartment.** Place a container of ice cream in the center of the freezer compartment. Check it after a day. If it's too hard or too soft, adjust the temperature controls.

**Always allow 24 hours for the refrigerator to reach the temperature you set.**

## Automatic Energy Saver System

You won't find an "energy saver" switch on this refrigerator.

Warm liquid from the refrigerator's condenser is automatically circulated around the front edge of the freezer compartment to help keep moisture from forming on the outside of the refrigerator during humid weather.

Many refrigerators use special electric heaters. This refrigerator needs none. That's why there is no "energy saver" switch—there's no need for it.

## No defrosting

It is not necessary to defrost the freezer or fresh food compartments. Your refrigerator is designed and equipped to defrost itself automatically.

## If you turn your household thermostat below 60°F. at night

... you may want to turn the *lettered* control one step colder, as from "C" to "D." Cooler temperatures in the house may cause the freezer controls to operate less frequently, thus allowing the freezer compartment to warm somewhat. To protect your frozen food supply, leave your *lettered* setting at this colder setting for the entire winter or for whatever period of time you are turning down your thermostat. This is especially important when the thermostat is turned down for an extended period.

This change should have no effect on your fresh food section. However, if freezing occurs, turn the numbered control one step warmer, as from "5" to "4."



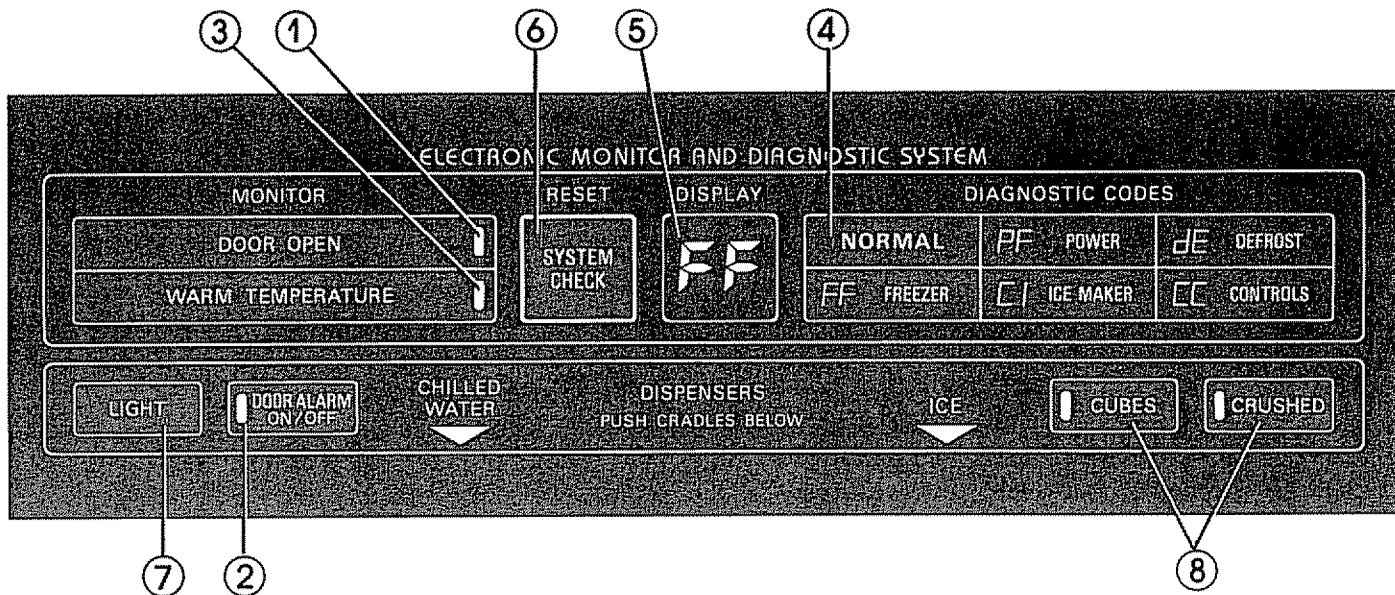

When you stop turning the thermostat down, turn temperature controls back to their regular settings.

# Electronic Monitor & Diagnostic System

It keeps an eye on things for you.



- ① Red signal light flashes to tell you when either door is open
- ② Green signal light tells you that the Door Alarm beeper has been set to sound after either door has been open 30 seconds
- ③ Red signal light tells you when freezer foodkeeping temperature is above normal.
- ④ Green lighted word **NORMAL** indicates that no failure has been detected by the diagnostic system
- ⑤ Flashing green diagnostic codes in the display warn you when:

-  frozen foods should be checked.
-  power has been interrupted.
-  icemaker may not be operating properly.
-  defrost system has failed
-  freezer control may need to be set for a colder temperature

What these codes mean—and what to do when they appear—is summarized on the inside of the freezer compartment door and explained more thoroughly on the following pages.

- ⑥ System Check pad puts a review of the electronic diagnosis of five coded functions at your fingertip and also allows you to erase codes from display.
- ⑦ Electronic control allows you to turn night light in water-and-ice dispenser on and off.
- ⑧ Electronic control allows you to select ice cubes or crushed ice, and green signal light confirms your choice

## When your refrigerator is first plugged in...

All panel lights come on for five seconds, a beep sounds, and lights go off except as follows:

- **PF** flashes in the display. Touch **SYSTEM CHECK-RESET** pad to erase it
- Green word **NORMAL** glows.
- Red **WARM TEMPERATURE** light glows if freezer compartment temperature is higher than normal. It goes off when proper foodkeeping temperature is reached.
- Door alarm beeper is activated and green light on **DOOR ALARM** pad glows.
- **CRUSHED** ice selection light glows.
- Red **DOOR OPEN** light flashes if either door is open, goes out when doors are shut.
- Night light in water-and-ice dispenser is off.

(continued next page)

## How to set the Door Alarm

You don't have to set the visual alarm. As long as either door is open, the red DOOR OPEN signal light flashes.

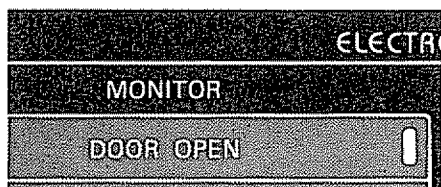

If the green signal light on the DOOR ALARM pad is glowing, the beeper alarm is set. If it's not, touch the pad to turn it on.

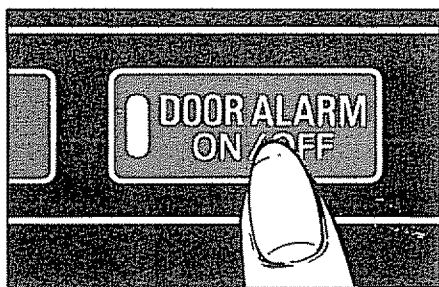

If either door is open for more than 30 seconds, a recurring beep sounds.

The light goes out and the beeping stops when you close the door.

**There are times when you'll want the Door Alarm beeper turned off.**

When you're rearranging a lot of food, for example. Just touch the pad. The green light will go out and the beeping will stop.

Deactivating the Door Alarm beeper does not turn the red DOOR OPEN light off—it keeps flashing until the door is closed.

## Why the red Warm Temperature light glows.

At first, it's probably because your newly-installed refrigerator hasn't completely cooled down yet. Wait a few hours for it to cool, and then the light will go out.

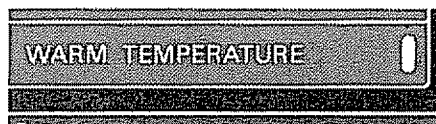

From then on, the red light will glow whenever temperatures inside get too high for proper food storage. If this happens, open the doors only when absolutely necessary, and close them as quickly as possible.

As soon as inside temperatures return to normal, the light goes out.

## How the Electronic Monitor and Diagnostic System works.

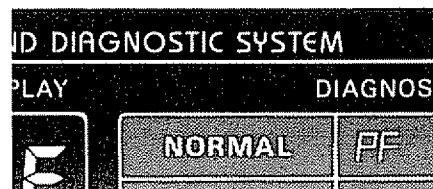

The word NORMAL is lighted in green except when a failure has been detected.

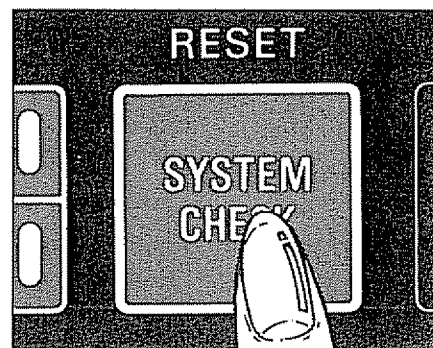

The SYSTEM CHECK pad has two functions:

- 1 You can touch the SYSTEM CHECK pad and get a review of the electronic diagnostic codes in order of their priority.
- 2 If a fault code is flashing, you can touch the SYSTEM CHECK pad to erase that code and check for other failures.

*(continued next page)*

## Electronic Monitor & Diagnostic System (continued)

The Electronic Monitor and Diagnostic System alerts you when something starts to go wrong.

If a diagnostic code appears on the display, something needs special attention.

To get your attention, the display code flashes until you erase it. The first 6 flashes are accompanied by beeps.

If more than one coded function requires attention at the same time, the one with the highest priority will be displayed first until erased. Then the one with the next highest priority will flash until erased. And so on.

The following codes are shown in order of their priority.

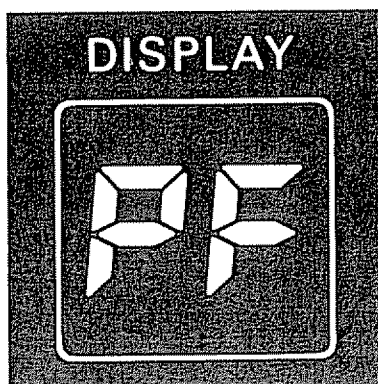

This flashing code tells you the **power to the refrigerator has been interrupted** for more than 2 seconds. Check the condition of food in both the fresh food and freezer compartments. Touch SYSTEM CHECK-RESET pad to erase code.

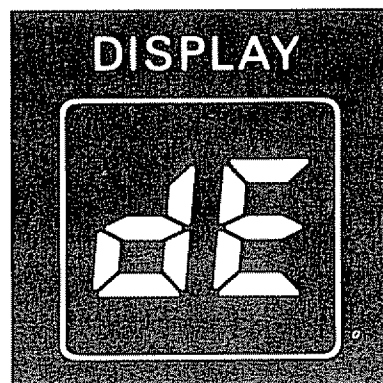

This flashing code tells you something's wrong with the defrost system—**keep doors closed to retain cold and call for service**. Touch SYSTEM CHECK-RESET pad to erase code and to check for other failures.

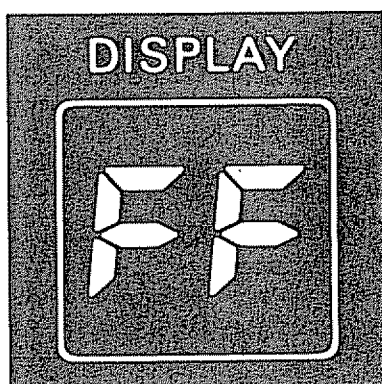

This flashing code tells you to **check your frozen food**. Has any of it started to thaw? A package may be holding the freezer compartment door open. Don't open the door more often than absolutely necessary until freezer compartment temperature returns to normal. Touch SYSTEM CHECK-RESET pad to erase code and to check for other failures. Call for service if necessary.

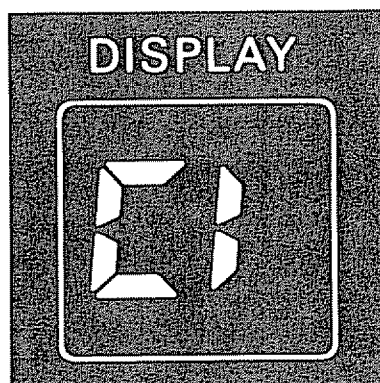

This flashing code tells you to **check the automatic icemaker**. Ice clumps in the storage bin may have stalled the icemaker. Follow corrective measures described on page 21. Touch SYSTEM CHECK-RESET pad to erase code. If code reappears, call for service.

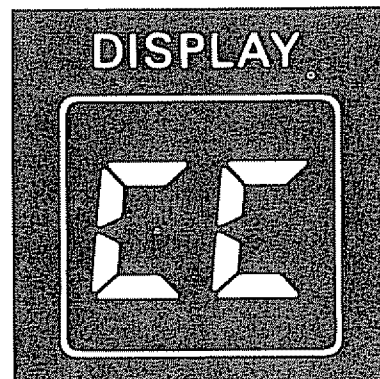

This flashing code tells you to **check temperature controls** and adjust them if necessary. (See directions on page 5.) Touch SYSTEM CHECK-RESET pad to erase code. If code reappears within 4 hours, call for service.

# Electronic Monitor & Diagnostic System (continued)

## Signal Lights and Diagnostic Codes

What they mean, and what to do when they alert you, is summarized on this panel on the inside of the freezer compartment door.

ELECTRONIC MONITOR AND DIAGNOSTIC SYSTEM	
DISPLAY	EXPLANATION / RECOMMENDED ACTION
NORMAL	ALL SYSTEMS OPERATING NORMALLY RESET SYSTEM CHECK TO CHECK SYSTEM .... TOUCH SYSTEM CHECK .... LOOK FOR "NORMAL" READOUT AFTER EACH CODE DISPLAY TOUCH SYSTEM CHECK TO ERASE DIAGNOSTIC CODES FROM DISPLAY
DOOR OPEN	DOORS NOT COMPLETELY CLOSED .... CHECK FOR OPEN BINS .... PACKAGES MAY BE BLOCKING DOOR
WARM TEMPERATURE	THIS MAY OCCUR WHEN REFRIGERATOR IS FIRST TURNED ON OR DOORS LEFT OPEN TOO LONG
FF FREEZER	CHECK FOR THAWING OF FROZEN FOODS .... LIMIT DOOR OPENINGS TO RETAIN COLD .... CALL FOR SERVICE IF NECESSARY
PF POWER	POWER HAS BEEN OFF FOR SOME PERIOD OF TIME .... CHECK CONDITION OF FOOD .... TOUCH RESET
CI ICE MAKER	CHECK ICE BIN FOR BLOCKAGE .... TOUCH RESET .... IF CODE APPEARS AGAIN, CALL FOR SERVICE
dE DEFROST	LIMIT DOOR OPENINGS TO RETAIN COLD .... CALL FOR SERVICE
CC CONTROLS	CHECK TEMPERATURE CONTROLS .... ADJUST IF NECESSARY .... TOUCH RESET .... IF CODE REAPPEARS WITHIN 4 HRS. CALL FOR SERVICE
SEE YOUR USE AND CARE BOOK FOR COMPLETE INSTRUCTIONS	
Your Direct Line to General Electric The GE Answer Center 800.626.7000 ?	

Panel located on the inside of the freezer compartment door.

Electronic Monitor & Diagnostic System

# Ice & Chilled Water Dispenser

## Automatic Icemaker and Ice & Water Dispenser

Your refrigerator has an automatic icemaker and a custom dispenser that dispenses chilled water, ice cubes and crushed ice through the freezer compartment door. Here's how they work.

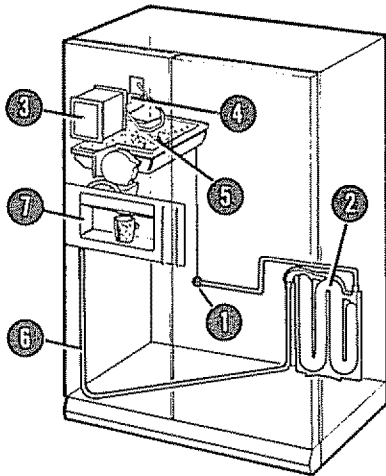

Water flows from household supply through dual solenoid valve (1) to water reservoir (2) and to automatic icemaker (3) as needed

Water is frozen in cube mold (4) and ejected into storage bin (5) where a motor-powered auger moves cubes forward to dispensing unit. When you touch the CUBES pad on front of freezer compartment door, ice cubes will dispense through chute in door when cradle is pressed

When you touch the CRUSHED pad, baffle in housing channels cubes through the crusher and crushed ice falls through chute into glass when cradle is pressed

Chilled water from reservoir flows through tubing in door (6) and is dispensed when cradle is pressed

Touch the LIGHT pad to turn the night light (7) in the dispenser on or off

## Important Facts about Your Custom Dispenser

- **Your icemaker will produce an average of five cubes an hour**—approximately 120 cubes in a 24-hour period—depending on freezer compartment temperature, room temperature, number of door openings and other use conditions. The ice storage bin holds about 250 cubes.
- **Intermittent dispensing of ice is normal.** If ice flow interruption is more than brief, ice clump(s) may be the cause and should be removed following instructions below and on page 12.
- **Overfilling glass with ice and use of narrow or extra-tall glasses should be avoided.** This can jam the chute or cause the door in the chute to freeze shut. Periodically open the freezer compartment door and look down into the chute. If ice is blocking the chute, poke it through with a wooden spoon.
- **To help keep bits of ice from being sprayed beyond the glass, place glass close to ice chute—but not so close that it blocks outgoing ice.**
- **Ice should not be dispensed into thin glasses, fine china or delicate crystal**—they can crack or chip from the combined pressure of your hand pressing them against the cradle and ice dropping into the container.
- **Ice should be dispensed before filling glass with soda or other beverage mixes.** This will prevent splashing which is annoying and which, if the splash reaches the ice and water selector switch, could cause it to stick or bind.
- **Beverages and foods should not be quick-chilled in the ice storage bin.** Cans, bottles or food packages in the storage bin can cause the icemaker to malfunction.
- **Ice other than that produced by your icemaker should not be added to the ice storage bin**—it may not crush and/or dispense well.

## Before Using Your Icemaker and Dispenser

If refrigerator is operated before water connection is made, keep manual icemaker switch in the OFF position

When water supply has been connected to icemaker, raise access door to ice bin and turn manual switch to ON position.

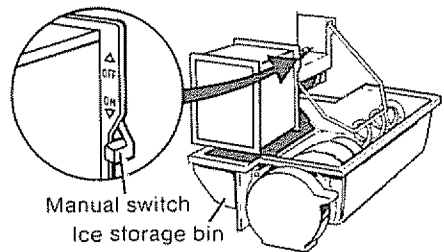
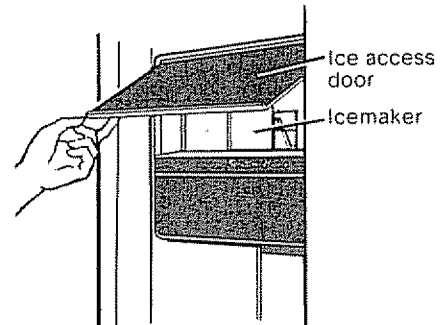

Depress water dispenser cradle for about two minutes to remove trapped air from water line and to fill water reservoir automatically

Ice cube mold automatically fills with water after cooling to freezing temperatures. First cubes normally freeze after several hours

**NOTE:** With a newly-installed refrigerator, allow about 24 hours for the freezer compartment to cool down to the proper ice-making temperature

(continued next page)

# Ice & Chilled Water Dispenser (continued)

## Once Your Icemaker and Dispenser Are in Operation

Throw away the first few batches of ice cubes (10 or 15 cubes). This will flush away any impurities in the water line. Do the same thing after vacations or extended periods when ice isn't used.

Discard the first half dozen glassfuls of water in the kitchen sink. This will eliminate the slight "plastic" taste temporarily imparted to the water by the water reservoir.

**Keep ice level to keep icemaker productive.** Cubes ejected into an empty storage bin will pile up close to the icemaker and push the feeler arm up to the OFF position prematurely when the bin is only partially full. Open the ice access door, reach in, level the cubes by hand and ice-making will resume. Keeping cubes distributed evenly will allow the icemaker to produce enough ice to fill the bin to its maximum capacity.

### Caution:

Under certain rare circumstances, ice cubes may be discolored, usually appearing with a green-bluish hue. The cause of this unusual discoloration is apparently due to a combination of factors such as certain characteristics of local waters, household plumbing and the accumulation of copper salts in an inactive water supply line which feeds the icemaker. Continued consumption of such discolored ice cubes may be injurious to health. If such discoloration is observed, discard the ice cubes and contact your General Electric Factory Service Center or an authorized Customer Care® servicer.

## To Dispense Ice and Water

- For ice, touch CUBES or CRUSHED pad. For water, simply position glass beneath words "CHILLED WATER"

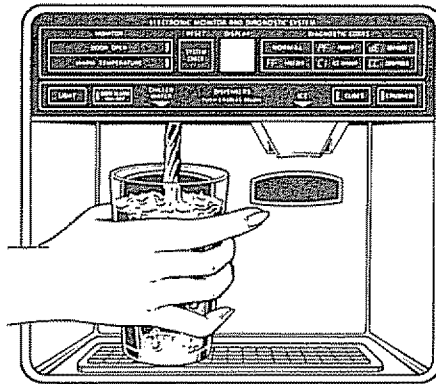
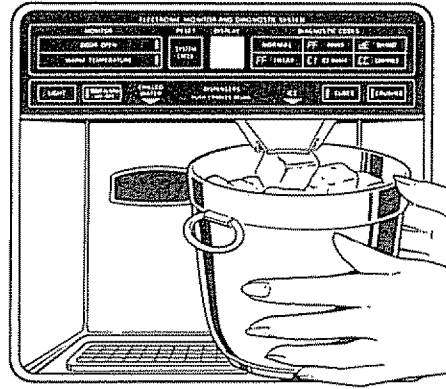

- Grip glass or other container gently near rim and press rim firmly against ice or water dispenser cradle

### Caution:

**Never put fingers or other objects into the ice crusher discharge opening.**

## When Dispensing Ice...

**Some crushed ice may be dispensed even though you touched the CUBES pad.** This happens occasionally when a few cubes inadvertently get diverted to the crusher.

**Sometimes a mound of snow will form on the door in the ice chute.** This condition is normal, and usually occurs when you have dispensed crushed ice repeatedly. The snow will eventually evaporate.

## When Dispensing Water...

**The water system provides approximately six successive 8-ounce glassfuls.** After this, several hours must be allowed for the new water reservoir supply to cool. You probably will not drain all the chilled water from the reservoir on a single occasion.

**The first glass of water dispensed may be warmer than the following ones.** This is normal.

**Dispensed water will be cooler than tap water but not as cold as ice water.** For colder water, simply add crushed ice or cubes before dispensing water.

## To Stop Dispensing

Release pressure from cradle and withdraw slowly to catch last bits of ice or drops of water

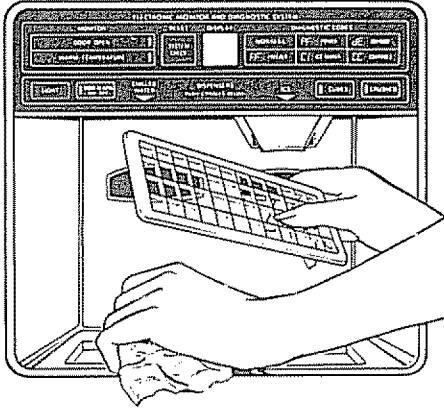

Some slight dripping may occur following dispensing of crushed ice or chilled water. If excessive, the spill should be wiped dry immediately.

Do not pour water in the spill shelf because it is not self draining—pour it in the kitchen sink. The shelf and its grille should be cleaned regularly according to instructions on page 17

## If Ice Clumps Form in Storage Bin...

The icemaker ejects cubes in groups of five, and it is normal for several cubes to be joined together. However, **infrequent usage of ice can cause ice clumps to form in the storage bin**, resulting in temporary malfunction of the dispenser mechanism

If this happens:

- remove storage bin from freezer compartment
- break up ice clumps with fingertip pressure and discard remaining clumps.
- replace bin before remaining cubes melt and fuse together

## To Remove Ice Cube Storage Container

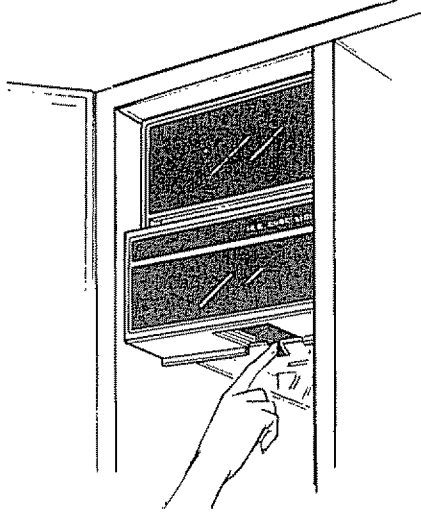

Simultaneously press up on tab under container and pull container straight out while supporting it at front and rear.

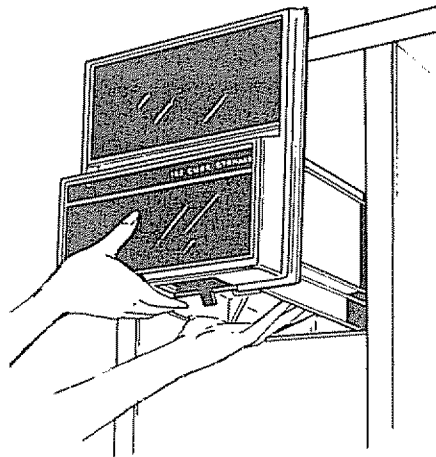

## If Ice Is Used Infrequently...

"Old" ice cubes will become cloudy and taste stale. Empty ice storage bin periodically and wash it in luke-warm water. Be sure to allow storage bin to cool before replacing it—otherwise ice cubes will stick to the metal auger.

## Turn the Manual Icemaker Switch to the OFF Position when...

- home water supply is to be turned off for several hours
- ice storage bin is to be removed for a period of time
- going away on vacation, at which time you should also turn off the valve in the water supply line to your refrigerator.

## If This Is Your First Icemaker...

You'll hear occasional sounds that may be unfamiliar. These are normal icemaking sounds and are not cause for concern.

# Food Storage Suggestions

## Suggested storage times for meat and poultry\*

Eating quality drops after time shown	IN REFRIGERATOR AT 35° to 40°F	IN FREEZER AT 0°F
	DAYS	MONTHS
<b>Fresh Meats</b>		
Roasts (Beef & Lamb)	3 to 5	6 to 12
Roasts (Pork & Veal)	3 to 5	4 to 8
Steaks (Beef)	3 to 5	6 to 12
Chops (Lamb)	3 to 5	6 to 9
Chops (Pork)	3 to 5	3 to 4
Ground & Stew Meats	1 to 2	3 to 4
Variety Meats	1 to 2	3 to 4
Sausage (Pork)	1 to 2	1 to 2
<b>Processed Meats</b>		
Bacon	7	1
Frankfurters	7	½
Ham (Whole)	7	1 to 2
Ham (Half)	3 to 5	1 to 2
Ham (Slices)	3	1 to 2
Luncheon Meats	3 to 5	Freezing not recommended
Sausage (Smoked)	7	
Sausage (Dry & Semi-Dry)	14 to 21	
<b>Cooked Meats</b>		
Cooked Meats and Meal Dishes	3 to 4	2 to 3
Gravy & Meat Broth	1 to 2	2 to 3
<b>Fresh Poultry</b>		
Chicken & Turkey (Whole)	1 to 2	12
Chicken (Pieces)	1 to 2	9
Turkey (Pieces)	1 to 2	6
Duck & Goose (Whole)	1 to 2	6
GIBLETS	1 to 2	3
<b>Cooked Poultry</b>		
Pieces (Covered with Broth)	1 to 2	6
Pieces (Not Covered)	3 to 4	1
Cooked Poultry Dishes	3 to 4	4 to 6
Fried Chicken	3 to 4	4
<b>(Other than for meats &amp; poultry)</b>		
Most fruits and vegetables		FREEZER 8-12 months
Lean fish		6-8 months
Fatty fish, rolls and breads, soups, stew, casseroles		2-3 months
Cakes, pies, sandwiches, left-overs (cooked), Ice cream (original carton)		1 month max

New techniques are constantly being developed. Consult the College or County Extension Service or your local Utility Company for the latest information on freezing and storing foods.

\*U.S. Department of Agriculture

Meats, fish and poultry purchased from the store vary in quality and age; consequently, safe storage time in your refrigerator will vary.

### To store unfrozen meats, fish and poultry:

- Always remove store wrappings
- Rewrap in foil, film or wax paper and refrigerate immediately.

To store cheese, wrap well with wax paper or aluminum foil, or put in a plastic bag.

- Carefully wrap to expel air and help prevent mold
- Store pre-packaged cheese in its own wrapping if you wish.

To store vegetables, use the vegetable drawers—they've been designed to preserve the natural moisture and freshness of produce.

- Crispness can be maintained by covering vegetables with a moist towel.

- As a further aid to freshness, pre-packaged vegetables can be stored in their original wrapping.

*Note: Special fresh food compartment drawers (on models so equipped) make it unnecessary to wrap certain foods which they've been designed to preserve. These drawers are described on page 14.*

To store ice cream—Fine-quality ice cream, with high cream content, will normally require slightly lower temperatures than more "airy" already-packaged brands with low cream content.

- It will be necessary to experiment to determine the freezer compartment location and temperature control setting to keep your ice cream at the right serving temperature
- The rear of the freezer compartment is slightly colder than the front

### Tips on freezing foods

There are three essential requirements for efficient home freezing

- 1. Initial quality.** Freeze only top-quality foods. Freezing retains quality and flavor; it cannot improve quality.
- 2. Speed.** The quicker fruits and vegetables are frozen after picking, the better the frozen product will be. You'll save time, too, because less culling and sorting will be necessary.
- 3. Proper packaging.** Use food wraps designed especially for freezing.

To freeze meat, fish and poultry, wrap well in freezer-weight foil (or other heavy-duty wrapping material) forming it carefully to the shape of the contents. This expels air. Fold and crimp ends of the package to provide a good, lasting seal.

Don't refreeze meat that has completely thawed; meat, whether raw or cooked, can be frozen successfully only once.

Limit freezing of fresh (unfrozen) meats or seafoods to 26 pounds at a time.

### Organize your food storage for convenience.

- Store all like things together. This not only saves time, but electricity—because you can find foods faster.
- Place the oldest items up front so they can be used up promptly
- Use the handy shelves on the door for most frequently used sauces and condiments.

- Use the meat drawer for meats you do not freeze

### To save money in energy and food costs.

- Place most perishable items such as milk, cream or cottage cheese toward the rear of the top shelf as they will stay coldest in this part of the fresh food compartment.
- Cover moist foods with tight lids, plastic film or foil
- Leaf vegetables and fruits placed in storage drawers will last longer when stored in closed plastic containers or wrapped in plastic film
- Do not overload your fresh food or freezer compartment with a lot of warm food at once
- Open the door the fewest times possible to save electrical energy.
- When going out of town for several days, leave as few perishables as possible in the refrigerator. Move the icemaker manual switch to "OFF" and shut off water to the refrigerator.

# General Electric Food-Saver System

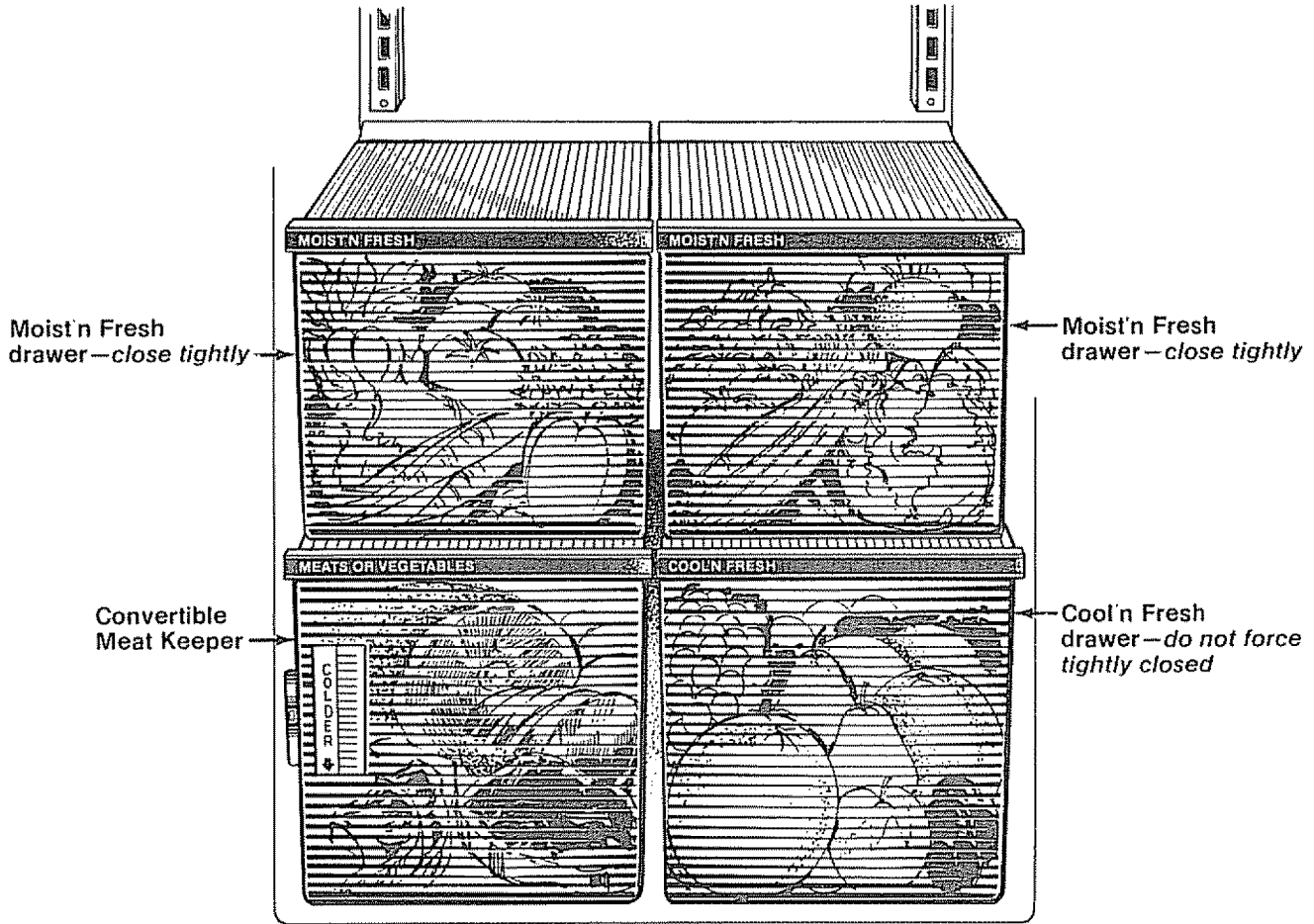

## Moist'n Fresh Drawers

The two top drawers are designed to keep **unwrapped foods** fresh by retaining the natural moisture content of foods such as:

- Artichokes
- Asparagus
- Beets, topped
- Blueberries
- Carrots
- Celery
- Cherries
- Corn
- Currants
- Greens, leafy
- Lettuce
- Parsley
- Peas, green
- Plums
- Radishes
- Rhubarb
- Spinach
- Tomatoes, ripe

As in any refrigerated storage area, **it is recommended that odorous foods be stored wrapped**—foods such as:

- Broccoli
- Brussels
- Sprouts
- Cabbage
- Cauliflower
- Green Onions
- Parsnips
- Turnips

Storage time will depend upon the type of food and its condition when placed in the drawer.

Excess water which may accumulate in the bottom of the Moist'n Fresh drawers should be poured out and the drawers wiped dry.

The Moist'n Fresh drawers are partially sealed by gaskets attached to the covers at the front and back edges. Always replace them in these covers and *push the drawers all the way in*.

## Cool'n Fresh Drawer

The lower right drawer is designed to provide lower humidity storage for items such as:

- Apples
- Apricots
- Grapes
- Mushrooms
- Nectarines
- Oranges
- Peaches
- Pears
- Raspberries
- Summer Squash
- Strawberries
- Tangerines

## Convertible Meat Keeper

(on models so equipped)

The "Meats or Vegetables" drawer has its own cold air duct to allow a stream of cold air from the freezer compartment to flow around the drawer.

The variable temperature control regulates the air flow from the freezer compartment

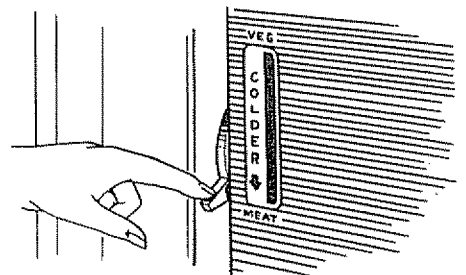

Set control lever to MEAT—the coldest setting—to store fresh meats. If lever is left in meat position for a long period of time, some frost may form on the inside of the drawer.

Set control lever to VEG to convert the drawer to normal refrigerator temperature and provide extra vegetable storage space. Cold air duct is turned off.

Variable settings between these extremes can be selected.

# Shelf Positions

## Drawer Removal

Drawers will stop before coming all the way out of refrigerator to help prevent contents from spilling onto floor. Drawers can easily be removed by tilting up slightly and pulling past "stop" location.

To remove drawers when the fresh food compartment door cannot be opened fully:

1. Pull the upper left drawer straight out
2. Lift the upper left drawer cover and pull it out.

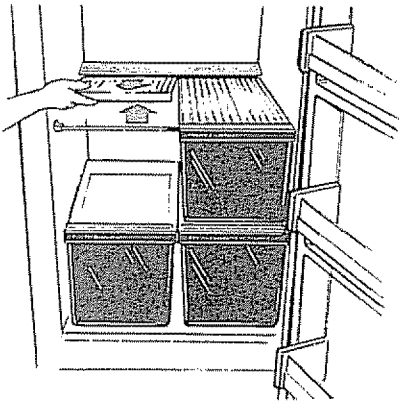

3. Slide the upper right drawer and cover to the left and remove them

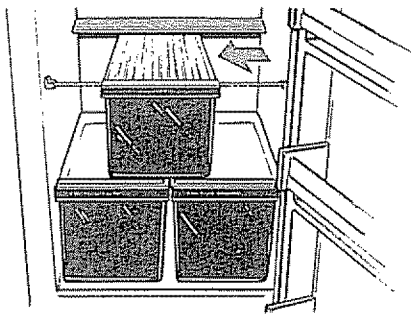

4. Pull the "Meats or Vegetables" drawer straight out, then lift its cover and remove it.

5. Slide the bottom right drawer and cover to the left and remove them.

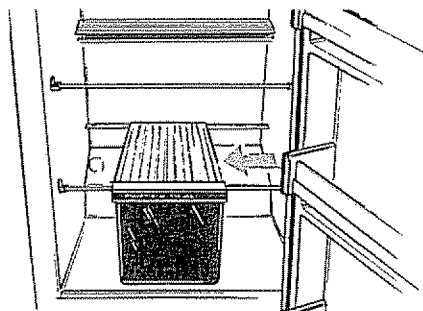

Simply replace in reverse order, making sure grooves at rear of covers engage supporting rods at rear of refrigerator. **"Meats or Vegetables" drawer must be returned to the lower left position.**

## Sealed Snack Pack (on models so equipped)

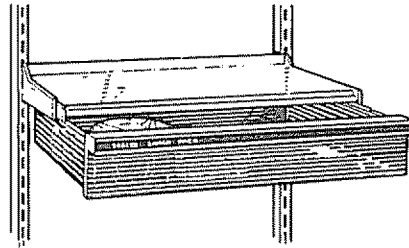

The Sealed Snack Pack—and shelf to which it is attached—can be relocated within the Fresh Food compartment. The sealed drawer retains high humidity for convenient storage of unwrapped meats and cheese, bacon, hors d'oeuvres, spreads and snacks.

## How to rearrange your shelves

### Adjustable Shelves

Shelves in the fresh food and freezer compartments are adjustable, enabling you to make efficient shelf arrangements to fit your family's food storage needs.

### Tempered Glass Shelves in Fresh Food Compartment

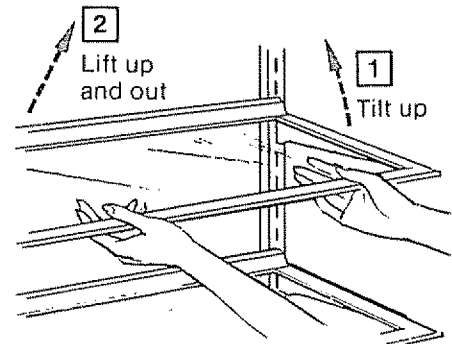

To remove shelves: Tilt shelf up at front, then lift it up and out of tracks on rear wall of refrigerator.

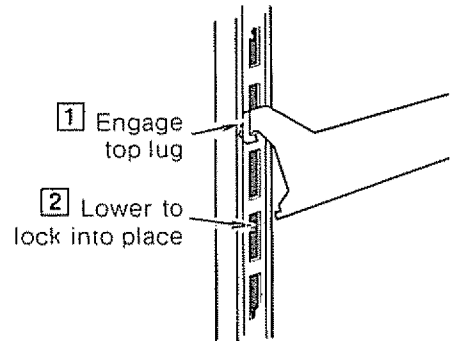

To relocate shelves: Select desired shelf height. With shelf front raised slightly, engage top lugs in tracks at rear of cabinet. Then lower front of shelf until it locks into position.

## Shelf Positions (continued)

### Removable Wine Rack (on models so equipped)

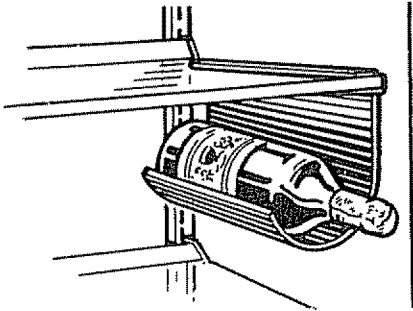

The wine rack is designed to hold a bottle on its side and will fit on any shelf

#### To relocate the wine rack:

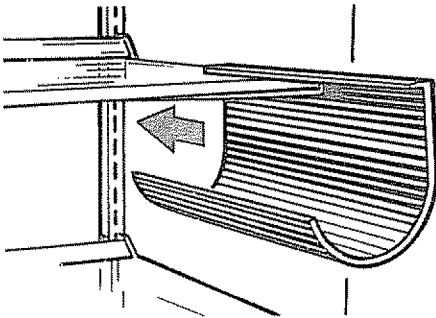

Pull wine rack straight out. Then position its lip over either edge of the shelf you want to suspend it from and push it all the way in

### Porta-Bins on Fresh Food Compartment Door (on models so equipped)

Adjustable Porta-Bins can easily be carried from refrigerator to work area. A dozen eggs in their original carton will fit securely in a Porta-Bin

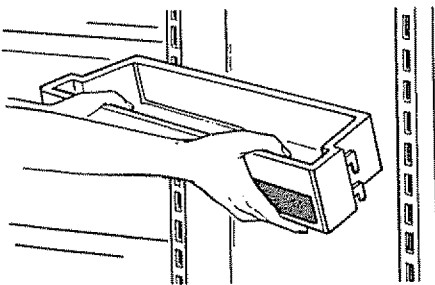

**To remove:** Lift Porta-Bin straight up until mounting hooks disengage

**To relocate:** Select desired shelf height, engage Porta-Bin's hooks in slots on the tracks of the door, and push in. Porta-Bin will lock in place.

### Multi-Position Shelves in Freezer Compartment

Shelf supports at various levels in the freezer compartment let you reposition the shelves from time to time to better accommodate your variable inventory of frozen foods.

#### To reposition shelves:

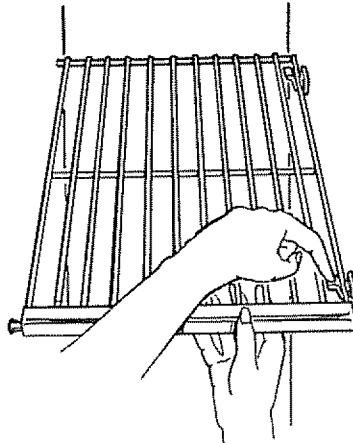

1. While pressing tabs on shelf supports on right wall, lift shelf out of grooves in supports

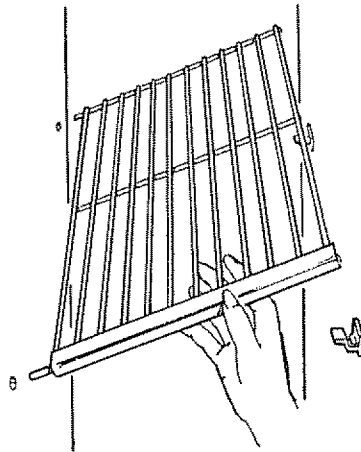

2. Pull shelf sideways until shelf rods come out of holes on left wall

3. Select desired shelf height and insert shelf rods into holes on left wall. **If shelf supports at desired level on right wall have tabs**, lower shelf into grooves on support while pressing tabs. Be sure shelf wire is fully inserted into grooves.

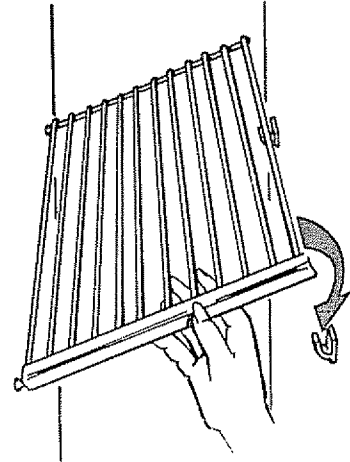

**If shelf supports at desired level on right wall do not have tabs**, merely lower shelf into place on supports

# User Maintenance Instructions

## Cleaning your refrigerator

### Outside

**Protect the paint finish.** The finish on the outside of the refrigerator is a high quality, baked-on paint finish. With proper care, it will stay new-looking and rust-free for years. Apply a coat of appliance polish wax when the refrigerator is new and then at least twice a year.

Appliance Polish Wax & Cleaner (Cat. No. WR97X216) is available from GE and Hotpoint Appliance Parts Marts

**Keep the finish clean.** Wipe with a clean cloth lightly dampened with appliance polish wax or mild liquid dishwashing detergent. Dry and polish with a clean, soft cloth. **Do not** wipe the refrigerator with a soiled dishwashing cloth or wet towel. **Do not use** scouring pads, powdered cleaners, bleach, or cleaners containing bleach

**Clean the door trim the same way.** Do not use gritty finish-dulling cleansers.

**Water-and-ice dispenser spill shelf** should be wiped dry immediately if excessive spills occur. Water allowed to remain on shelf may leave deposits removable by soaking with a mixture of one teaspoon of a non-precipitating water softening compound (such as Calgon brand) or citric acid powder per pint of hot tap water or undiluted vinegar. Soak until deposit disappears or becomes loose enough to rinse away. Usually 30 minutes soaking time is adequate.

### Inside

Clean both fresh food and freezer compartments at least once a year. It is recommended that the refrigerator be unplugged before cleaning. If this is not practical, wring excess moisture out of sponge or cloth when cleaning in the vicinity of switches, lights or controls

Use warm water and baking soda solution—about a tablespoon of baking soda to a quart of water. Rinse thoroughly with water and wipe dry. Follow this same procedure for cleaning door gaskets, meat and vegetable drawers, and all plastic parts. Wash ice storage bin in lukewarm water only. **Do not** use cleansing powders or other abrasive cleaners.

**Do not wash any plastic parts from your refrigerator in your automatic dishwasher.**

### Electronic Monitor and Diagnostic System Panels

Clean the panels on the outside and inside of the freezer compartment door with a glass cleaner, such as Windex brand, and a soft, clean cloth

### Behind

Care should be taken in moving your refrigerator away from the wall. All types of floor coverings can be damaged, particularly cushioned coverings and those with embossed surfaces. Pull the refrigerator straight out and return it to position by pushing it straight in. Moving your refrigerator in a side direction may result in damage to your floor covering or refrigerator

### Condenser

For most efficient operation, remove the base grille (see page 4) and remove the defrost water pan, then either sweep away or vacuum up dust that is readily accessible. This easy cleaning operation should be done at least once a year.

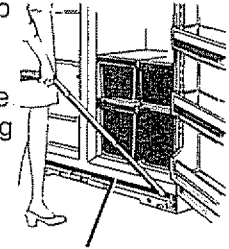

Condenser

### Defrost Water Pan

Pan located behind base grille should be cleaned at least once a year. When reinstalling pan, firmly push pan ALL THE WAY IN until it stops

### Drain Opening in Freezer Compartment

During yearly cleaning, remove bottom freezer basket and pour a solution of baking soda (one teaspoon) and two cups of warm (not boiling) water into the drain opening at the bottom rear of the freezer compartment. This will help eliminate odor and reduce clogging of the drain line to the defrost water pan. Then empty and clean the defrost water pan and replace it.

## When you go on vacation

**For extended vacations or absences**, shut off power to refrigerator, turn the numbered control OFF. Clean interior with baking soda solution of one table-spoon of soda to one quart of water. Wipe dry. To prevent odors, leave open box of soda in refrigerator. Leave doors open.

**For shorter vacations**, remove perishable foods and leave controls at regular settings. However, if room temperature is expected to drop below 60°F, follow same instructions as for extended vacations.

Move icemaker manual switch to OFF position and be sure to shut off water supply. ON-OFF switch is located near the front of the icemaker.

## When you move

Disconnect power cord from wall receptacle, remove all food and clean and dry the interior.

**Secure all loose items** such as grille, shelves, and storage pans by taping them securely in place to prevent damage.

Be sure refrigerator stays in *upright position only* during actual moving and in van. Refrigerator must be secured in van to prevent movement. Protect outside of refrigerator with blanket.

## Accessory

### The perfect companion to your automatic icemaker—Quadra Kleen Water Filter

Your ice cubes can only be as clear and fresh-tasting as the water that produces them. That's why it's a good idea to purify your water with a Quadra Kleen Water Filter.

Its activated charcoal removes musty, stale odors and unpleasant medicinal, metallic tastes. A porous fiber cartridge catches dirt, rust particles, sand and silt while special crystals reduce deposits of hard scale.

The water filter is an option at extra cost and is available from your GE dealer. Specify WR97X214. It has complete installation instructions and installs in minutes on 1/4" O.D. copper water line.

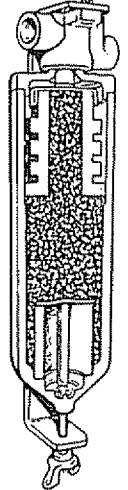

To save time and money, check the Problem Solver before you request service.

If you have a problem, it may be minor. You may be able to correct it yourself. Just use this Problem Solver to locate your problem and then follow the suggested recommendations.

## Rapid Electrical Diagnosis

Your refrigerator is wired for accurate electrical diagnosis in your home—takes only minutes for a service technician to check its entire electrical system. No need for the technician to unplug, move or unload the refrigerator to make the diagnosis.

## The Problem Solver

Save time and money...before you request service, check the following:

PROBLEM	POSSIBLE CAUSE AND REMEDY
NO PANEL TOUCH PAD RESPONSE	<ul style="list-style-type: none"> <li>• If interior light is not on, refrigerator may not be plugged in at wall outlet.</li> <li>• If plug is secure and the refrigerator still fails to operate, plug a lamp or a small appliance into the same outlet to determine if there is a tripped circuit breaker or burned out fuse.</li> </ul>
REFRIGERATOR DOES NOT OPERATE	<ul style="list-style-type: none"> <li>• May be in defrost cycle when motor does not operate for about 30 minutes.</li> <li>• Temperature control in OFF position.</li> <li>• If interior light is not on, refrigerator may not be plugged in at wall outlet.</li> <li>• If plug is secure and the refrigerator still fails to operate, plug a lamp or a small appliance into the same outlet to determine if there is a tripped circuit breaker or burned out fuse.</li> </ul>
MOTOR OPERATES FOR LONG PERIODS	<ul style="list-style-type: none"> <li>• Modern refrigerators with more storage space and a larger freezer compartment require more operating time.</li> <li>• Normal when refrigerator is first delivered to your home—usually requires 24 hours to completely cool down.</li> <li>• Large amounts of food placed in refrigerator to be cooled or frozen.</li> <li>• Hot weather—frequent door openings.</li> <li>• Door left open.</li> <li>• Temperature controls are set too cold. Refer to page 5.</li> <li>• Grille and condenser need cleaning. Refer to page 17.</li> <li>• Check ENERGY SAVING TIPS on page 2.</li> </ul>
MOTOR STARTS & STOPS FREQUENTLY	<ul style="list-style-type: none"> <li>• Temperature control starts and stops motor to maintain even temperatures.</li> </ul>
VIBRATION OR RATTLING	<ul style="list-style-type: none"> <li>• If refrigerator vibrates, more than likely it is not resting solidly on the floor and front roller screws need adjusting or floor is weak or uneven. Refer to ROLLERS, page 4.</li> <li>• If dishes vibrate on shelves, try moving them. Slight vibration is normal.</li> <li>• Defrost water pan rattling, needs to be positioned properly.</li> </ul>

(continued next page)

## The Problem Solver (continued)

PROBLEM	POSSIBLE CAUSE AND REMEDY
HOT AIR FROM BOTTOM OF REFRIGERATOR	<ul style="list-style-type: none"> <li>• Normal air flow cooling motor. <i>In the refrigeration process, it is normal that heat be expelled in the area under the refrigerator. Some floor coverings will discolor at these normal and safe operating temperatures. Your floor covering supplier should be consulted if you object to this discoloration.</i></li> </ul>
DOOR NOT CLOSING PROPERLY	<ul style="list-style-type: none"> <li>• Door gasket on hinge side sticking or folding over. To correct, put a small amount of petroleum jelly on face of gasket.</li> </ul>
OPERATING SOUNDS	<ul style="list-style-type: none"> <li>• The high speed compressor motor required to maintain near zero temperatures in the large freezer compartment may produce higher sound levels than your old refrigerator.</li> <li>• Normal fan air flow—one fan blows cold air through the refrigerator and freezer compartments—another fan cools the compressor motor.</li> <li>• These NORMAL sounds will also be heard from time to time:               <ul style="list-style-type: none"> <li>• Defrost timer switch clicks at defrost.</li> <li>• Defrost water dripping into drain pan.</li> <li>• Temperature control clicks ON or OFF.</li> <li>• Refrigerant boiling or gurgling.</li> <li>• Cracking or popping of cooling coils caused by expansion and contraction during defrost and refrigeration following defrost.</li> <li>• With automatic icemaker, the sound of cubes dropping into the bin and water running in pipes as icemaker refills.</li> </ul> </li> </ul>
FRESH FOOD OR FREEZER COMPARTMENT TEMPERATURE TOO WARM	<ul style="list-style-type: none"> <li>• Temperature control not set cold enough. Refer to page 5.</li> <li>• Warm weather—frequent door openings.</li> <li>• Door left open for long time.</li> <li>• Package may be holding door open.</li> </ul>
FOODS DRY OUT	<ul style="list-style-type: none"> <li>• Foods not covered, wrapped or sealed properly.</li> </ul>
FROST OR ICE CRYSTALS ON FROZEN FOOD	<ul style="list-style-type: none"> <li>• Door may have been left ajar or package holding door open.</li> <li>• Too frequent and too long door openings.</li> <li>• Frost within package is normal.</li> </ul>
SLOW ICE CUBE FREEZING	<ul style="list-style-type: none"> <li>• Door may have been left ajar.</li> <li>• Turn temperature of freezer compartment colder.</li> </ul>
ICE CUBES HAVE ODOR/TASTE	<ul style="list-style-type: none"> <li>• Old cubes need to be discarded.</li> <li>• Ice storage bin needs to be emptied and washed.</li> <li>• Unsealed packages in fresh food and/or freezer compartments may be transmitting odor/taste to ice cubes.</li> <li>• Interior of refrigerator needs cleaning—refer to page 17.</li> <li>• Poor-tasting incoming water. Install Quadra Clean water filter—see page 18</li> </ul>

PROBLEM	POSSIBLE CAUSE AND REMEDY
AUTOMATIC ICEMAKER DOES NOT WORK	<ul style="list-style-type: none"> <li>• ON-OFF control in OFF position.</li> <li>• Water supply turned off or not connected.</li> <li>• Freezer compartment too warm.</li> <li>• Cubes too small—water shut-off valve connecting refrigerator to home water line may be clogged.</li> <li>• Piled up cubes in storage bin may cause icemaker to shut off prematurely. Shut off icemaker and level cubes in bin.</li> </ul>
CUBE DISPENSER DOES NOT WORK	<ul style="list-style-type: none"> <li>• No ice cubes. Remove storage container. If cubes are frozen to wire arm, remove cubes.</li> <li>• No ice cubes. Icemaker turned off or water supply turned off.</li> <li>• Irregular ice clumps in storage container. Break up as many as you can with fingertip pressure and discard the remaining clumps</li> </ul>
WATER HAS POOR TASTE/ODOR	<ul style="list-style-type: none"> <li>• If water dispenser has not been used for an extended period, dispense water in regular manner until all water in reservoir is replenished with fresh water.</li> <li>• Poor-tasting incoming water. Install Quadra Clean water filter—see page 18.</li> </ul>
WATER IN FIRST GLASS IS WARM	<ul style="list-style-type: none"> <li>• Allow about 24 hours for water to cool to proper temperature after refrigerator is first installed.</li> <li>• If water dispenser has not been used for extended period, water in first glass will not be as cool as in succeeding glasses</li> <li>• If water reservoir has been drained, allow several hours for replenished supply to chill.</li> </ul>
WATER DISPENSER DOES NOT WORK	<ul style="list-style-type: none"> <li>• Water supply line turned off or not connected.</li> <li>• Supply line may be clogged with sediment.</li> </ul>
DIVIDER BETWEEN FRESH FOOD AND FREEZER COMPARTMENTS FEELS WARM	<ul style="list-style-type: none"> <li>• Normal warmth is created by automatic energy saver system circulating warm liquid around front edge of freezer compartment to help prevent condensation on outside of refrigerator in hot, humid weather.</li> </ul>
MOISTURE FORMS ON OUTSIDE OF REFRIGERATOR	<ul style="list-style-type: none"> <li>• Not unusual during period of high humidity.</li> </ul>
REFRIGERATOR HAS ODOR	<ul style="list-style-type: none"> <li>• Foods with strong odors should be tightly covered.</li> <li>• Check for spoiled food.</li> <li>• Interior needs cleaning. Refer to page 17.</li> <li>• Defrost water pan needs cleaning.</li> <li>• Keep open box of baking soda in refrigerator; replace monthly.</li> </ul>

(continued next page)

# The Problem Solver (continued)

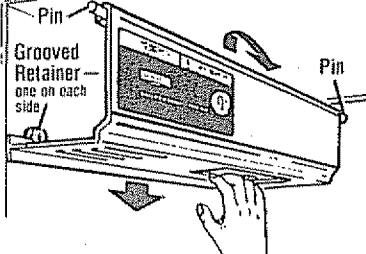
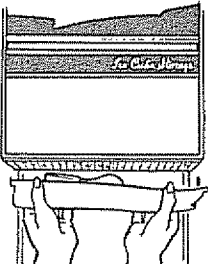
PROBLEM	POSSIBLE CAUSE AND REMEDY
MOISTURE COLLECTS INSIDE	<ul style="list-style-type: none"> <li>• Too frequent and too long door openings</li> <li>• In humid weather air carries moisture into refrigerator when doors are opened.</li> </ul>
WATER ON FLOOR	<ul style="list-style-type: none"> <li>• Defrost water pan full, missing or not in position.</li> </ul>
TO REPLACE A LIGHT BULB IN FRESH FOOD COMPARTMENT:	<ol style="list-style-type: none"> <li>1. Unplug refrigerator.</li> <li>2. Turn numbered temperature control to OFF and pull off knob</li> <li>3. Pull bottom of light panel down about ¼"—just enough to disengage lip at rear from grooves in retainers on rear wall.</li> <li>4. Lift panel to disengage top from pins on side walls, and remove panel</li> </ol> <p>After replacing with same size bulb, reinstall panel (hang top on pins; pull bottom down, push it back and release it to let lip engage grooves in retainers). Replace temperature control knob in OFF position, turn it to previous setting, and plug refrigerator back in.</p> 
TO REPLACE A LIGHT BULB IN FREEZER COMPARTMENT:	<ol style="list-style-type: none"> <li>1. Unplug refrigerator.</li> <li>2. Remove the shelf that's just below light shield (Shelf will be easier to remove if it is emptied first )</li> <li>3. Pull plastic light shield toward you. (It will bend to free tabs from grooves )</li> <li>4. Replace bulb with same size bulb.</li> <li>5. Reinstall shield and shelf.</li> <li>6. Plug in refrigerator.</li> </ol> 

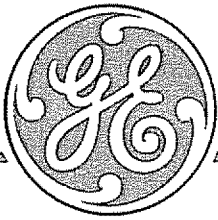

# Consumer Services

At General Electric we're committed to providing you with the best appliances we know how to build and we know that you want your appliances to give you many years of dependable service.

Our Consumer Services are designed with your needs and wants in mind.

# 1.

## Warranty Protection

Your new appliance is a well designed and engineered product. Before it left the factory, it went through rigorous tests to detect manufacturing defects. And you have a written warranty to protect you.

See the warranty on the back page of this book for details.

# 2.

## Prompt Service at your Convenience

Whether your appliance is in or out of warranty, you're just a phone call away from our nationwide network of Factory Trained Service professionals.

Simply call our GE service organization. You'll find them in the White Pages under "General Electric Company" or "General Electric Factory Service," and in the Yellow Pages under "General Electric Customer Care" Service."

Service is scheduled at your convenience and the technician drives a fully-stocked parts service truck so that, in most cases, the repair can be completed in one visit.

We're proud of our service and want you to be pleased, but if for some reason you are not happy with the service you receive, here are three steps to follow for further help.

FIRST, contact the people who serviced your appliance. Explain why you are not pleased. In most cases, this will solve the problem.

NEXT, if you are still not pleased write all the details — including your phone number to:

Manager, Consumer Relations  
General Electric Company  
Appliance Park  
Louisville, Kentucky 40225

FINALLY, if your problem is still not resolved, write:

Major Appliance Consumer Action Panel  
20 North Wacker Drive  
Chicago, Illinois 60606

# 3.

## Service Contracts For trouble-free service beyond the written warranty period.

If you prefer to budget your repair expenditures instead of being surprised by them, GE offers service contracts for varying lengths of time on all GE major appliances. With a contract, we'll

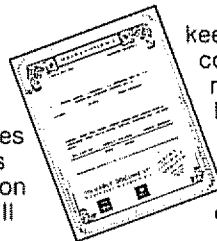

keep your appliance in good operating condition during the contract period at no additional charge. Service contracts let you pay today's prices for service a month, a year, or several years from now. And, you'll receive service from GE trained service technicians using only Genuine GE parts.

# 4.

## The Quick Fix® System You can save money and time by doing it yourself.

For do-it-yourselfers who would prefer to fix GE major appliances themselves... GE offers an industry first, the Quick Fix™ System.

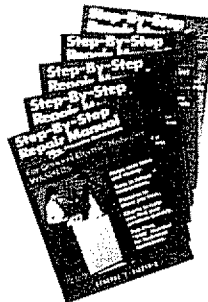

A program for do-it-yourself appliance repair, the system includes *step-by-step repair manuals* for refrigerators, most non-microwave electric ranges, dishwashers, and standard and large capacity washers and dryers, plus *specially packaged replacement parts*, and technical help with a *toll-free 800 number*.

# 5.

## Help for You by Phone

Should you need help in the selection and purchase of new appliances, or have questions about the operation of the GE appliances you now own—or have any other questions about our consumer products or services, you are only a TOLL-FREE call away.

The GE Answer Center™ 800.626.2000 consumer information service is open 24 hours a day, seven days a week.

Our staff of experts stands ready to assist you anytime.



# YOUR GENERAL ELECTRIC REFRIGERATOR WARRANTY

Save proof of original purchase date such as your sales slip or cancelled check to establish warranty period.

## WHAT IS COVERED

### FULL ONE-YEAR WARRANTY

For one year from date of original purchase, we will provide, free of charge, parts and service labor in your home to repair or replace **any part of the refrigerator** that fails because of a manufacturing defect.

### FULL FIVE-YEAR WARRANTY

For five years from date of original purchase, we will provide, free of charge, parts and service labor in your home to repair or replace **any part of the sealed refrigerating system** (the compressor, condenser, evaporator and all connecting tubing) that fails because of a manufacturing defect.

This warranty is extended to the original purchaser and any succeeding owner for products purchased for ordinary home use in the 48 mainland states, Hawaii and Washington, D.C. In Alaska the warranty is the same except that it is LIMITED because you must pay to ship the product to the service shop or for the service technician's travel costs to your home.

All warranty service will be provided by our Factory Service Centers or by our authorized Customer Care® servicers during normal working hours.

Look in the White or Yellow Pages of your telephone directory for GENERAL ELECTRIC COMPANY, GENERAL ELECTRIC FACTORY SERVICE, GENERAL ELECTRIC-HOTPOINT FACTORY SERVICE or GENERAL ELECTRIC CUSTOMER CARE® SERVICE.

## WHAT IS NOT COVERED

- Service trips to your home to teach you how to use the product.
- Read your Use and Care material.** If you then have any questions about operating the product, please contact your dealer or our Consumer Affairs office at the address below, or call, toll free:
- The GE Answer Center™  
800.626.2000  
consumer information service

- Improper installation.

If you have an installation problem, contact your dealer or installer. You are responsible for providing adequate electrical, plumbing and other connecting facilities.

- Replacement of house fuses or resetting of circuit breakers.
- Failure of the product if it is used for other than its intended purpose or used commercially.
- Damage to product caused by accident, fire, floods or acts of God.

**WARRANTOR IS NOT RESPONSIBLE FOR CONSEQUENTIAL DAMAGES.**

Some states do not allow the exclusion or limitation of incidental or consequential damages, so the above limitation or exclusion may not apply to you. This warranty gives you specific legal rights, and you may also have other rights which vary from state to state. To know what your legal rights are in your state, consult your local or state consumer affairs office or your state's Attorney General.

**Warrantor: General Electric Company**

**If further help is needed concerning this warranty, contact:  
Manager—Consumer Affairs, General Electric Company, Appliance Park, Louisville, KY 40225**