

# SNAPPER®

**ASSEMBLY INSTRUCTIONS**  
**OPERATOR'S MANUAL**  
**PARTS LIST**



## Z-VAC

### *Clamshell Grass Catcher Kit for NZM Mid Mount Riders*

Actual product may differ from product pictured above

#### ***Models covered:***

Includes Clamshell, Blower  
and Weight Kits

48" Kit	P/N 7600003
52" Kit	P/N 7600004
61" Kit	P/N 7600005

# **1 preliminaries**

## ***Congratulations!***

You have just purchased one of the finest pieces of outdoor power equipment on the market today. If properly cared for, your new Z-Vac Grass Catcher Kit will provide years of dependable service. Please read and follow this instruction manual carefully in order to get the most out of your new equipment.

As you carefully unpack your unit, you will find the following items:

- 1 Blower Kit (48" P/N 3071107, 52" P/N 3071108, 61" P/N 3063348)**
- 1 Clamshell Catcher Kit (All, 7063382)**
- 1 Weight Kit (All, 3071110)**
- 1 Package containing operating manuals and warranty registration**

Each product leaves our factory in excellent condition; occasionally, however, some damage may occur during shipment. If any such damage is found upon initial inspection, immediately notify the transport carrier who delivered your machine, as they are solely responsible for such damage, as well as any subsequent adjustments necessary.

Before assembly, please take a moment and record your model number and serial number below for future reference (both numbers are located on the serial tag attached to the blower):

**Model number** \_\_\_\_\_

**Serial number** \_\_\_\_\_

Also be sure to promptly fill out and return the warranty registration enclosed in your manual packet.

Your new unit requires very little assembly. Simply follow the instructions contained within this manual to begin enjoying the benefits of your new unit.



## **IMPORTANT! READ CAREFULLY THE FOLLOWING SAFETY RULES BEFORE ASSEMBLING OR OPERATING UNIT.**

### **TRAINING**

- Read, understand, and follow all instructions in the manual and on the unit before starting. If the operator(s) or mechanic(s) can not read English it is the owner's responsibility to explain this material to them.
- Become familiar with the safe operation of the equipment, operator controls, and safety signs.
- All operators and mechanics should be trained. The owner is responsible for training the users.
- Only allow responsible adults, who are familiar with the instructions, to operate the unit.
- Never let children or untrained people operate or service the equipment. Local regulations may restrict the age of the operator.
- The owner/user can prevent and is responsible for accidents or injuries occurring to themselves, other people or property.

### **PREPARATION**

- Evaluate the terrain to determine what accessories and attachments are needed to properly and safely perform the job. Use only accessories and attachments approved by the manufacturer.
- Wear appropriate clothing including safety shoes, safety glasses and ear protection. Long hair, loose clothing or jewelry may get tangled in moving parts.
- Inspect the area where the equipment is to be used and remove all objects such as rocks, toys and wire, which can be thrown by the machine.
- Use extra care when handling gasoline and other fuels. They are flammable and vapors are explosive.
  - a) Use only an approved container.
  - b) Never remove fuel cap or add fuel with the engine running. Allow engine to cool before refueling. Do not smoke.
  - c) Never refuel or drain the machine indoors.
- Check that operator's presence controls, safety switches and shields are attached and functioning properly. Do not operate unless they are functioning properly.

### **OPERATION**

- Never run an engine in an enclosed area.
- Operate only in the daylight or with good artificial light, keeping away from holes and hidden hazards.
- Be sure of your footing while using pedestrian controlled equipment, especially when backing up. Walk, don't run.
- Do not operate in reverse unless absolutely necessary. Always look down and behind before and while traveling in reverse.
- Be aware of the blower discharge direction and do not point it at anyone. Do not operate the blower without hose and bagger hood in place.
- Never leave a running unit unattended. Always stop

engine before leaving unit.

- Never operate with guards not securely in place. Be sure all safety features are attached, adjusted properly and functioning properly.
- Never operate with the hose or cover removed or altered.
- Do not change the engine governor setting or over speed the engine.
- Stop on level ground, shut off engine before leaving the operator's position for any reason.
- Stop equipment and inspect impeller blades after striking objects or abnormal vibration occurs. Make necessary repairs before resuming operations.
- Keep hands and feet away intake and discharge areas.
- Keep pets and bystanders away.
- Do not operate the unit while under the influence of alcohol or drugs.
- Use caution when crossing roads and sidewalks. Stop engine if not blowing.
- Use care when loading or unloading the machine into a trailer or truck.
- Use care when approaching blind corners, shrubs, trees or other objects that may obscure vision.

### **SLOPE OPERATION**

Slopes are a major factor related to loss-of-control and tip-over accidents, which can result in severe injury or death. All slopes require extra caution. If you cannot back up the slope, or if you feel uneasy on it, do not drive on it.

#### **Do**

- Mow up and down slopes, never across face.
- Remove obstacles such as rocks, tree limbs, etc.
- Watch for holes, ruts, or bumps. Uneven terrain could overturn the unit. Tall grass can hide obstacles.
- Keep all movement on the slopes slow and gradual. Do not make sudden changes in speed or direction.

#### **Do Not**

- Do not start or stop on a slope. If tires lose traction, proceed slowly straight down the slope.
- Do not turn on slopes unless necessary, and then, turn slowly and gradually downhill, if possible.
- Do not use near drop-offs, ditches, or embankments. The operator could lose footing or balance or blower could suddenly turn over if a wheel is over the edge of a cliff or ditch, or if an edge caves in.
- Do not operate on slopes with wet grass. Reduced footing or traction could cause sliding.
- Do not operate machine on slopes in excess of 10 degrees (18% grade) when equipped with a grass catcher.
- Do not operate machine without weight kit installed when equipped with a grass catcher.

## **2** *safety rules regarding outdoor power equipment*

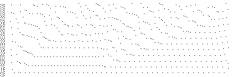

### **CHILDREN**

Tragic accidents can occur if the operator is not alert to the presence of children. Children are often attracted to the unit and its activity. Never assume that children will remain where you last saw them.

- Keep children out of the mowing area and under the watchful care of another responsible adult.
- Do not allow children or others to ride on the machine, attachment, or towed equipment (even with the blades off).
- Be alert and turn unit off if children enter the area.
- Before and during reverse operation, look behind and down for small children.
- Never allow children to operate the unit.
- Use extra care when approaching blind corners, shrubs, trees, or other objects that may obscure vision.

### **EMISSIONS**

- Engine exhaust from this product contains chemicals known, in certain quantities, to cause cancer, birth defects, or other reproductive harm.
- Look for the relevant Emissions Durability Period and Air Index information on the engine emissions label.

### **MAINTENANCE AND STORAGE**

- Always observe safe refueling and fuel handling practices when refueling the unit after transportation or storage.
- Always follow the engine manual instructions for storage preparations before storing the unit for both short and long term periods.
- Always follow the engine manual instructions for proper start-up procedures when returning the unit to service.
- Never store the machine or fuel container inside where there is an open flame, such as in a water heater. Allow unit

to cool before storing.

- Shut off fuel while storing or transporting. Do not store fuel near flames or drain indoors.
- Keep all hardware tight and keep all parts in good working condition. Replace all worn or damaged decals.
- Never tamper with safety devices. Check their proper operation regularly.
- Clean leaves and debris from mufflers and engine to prevent fires. Clean up oil or fuel spillage.
- Stop and inspect the equipment if you strike an object. Repair, if necessary, before restarting.
- Never make adjustments or repairs with the engine running unless specified otherwise.
- Park machine on level ground. Never allow untrained personnel to service machine.
- Carefully release pressure from components with stored energy. (e.g. springs)
- Only replace impellers. Never straighten or weld them.
- Keep hands and feet away from moving parts.
- Frequently check components and replace with manufacturer's recommended parts, when necessary.
- Use only factory authorized replacement parts when making repairs.
- Always comply with factory specifications on all settings and adjustments.
- Only authorized service locations should be utilized for major service and repair requirements.
- Never attempt to make major repairs on this unit unless you have been properly trained. Improper service procedures can result in hazardous operation, equipment damage and voiding of manufacturer's warranty.

## BLOWER KIT INSTALLATION

**STEP 1:** Remove pin, rod and spring securing discharge deflector to mower deck, and remove deflector. Set rod and pin aside for future assembly step. Store deflector for future use. **IMPORTANT:** Never operate mower without discharge deflector or grass catcher securely in place.

**STEP 2:** Remove two bolts securing right deck pulley guard to mower deck and remove guard. Set bolts aside for future assembly step. Store guard for future use. **IMPORTANT:** Never operate mower without a pulley guard securely in place.

**STEP 3:** Lift off and set aside foot rest/center deck cover to expose senter blade deck. Pull blade belt deck idler arm in direction indicated to relieve belt tension, and slip blade belt off of right blade drive pulley.

**NOTE:** Assistance may be needed for removal of blade belt.

**STEP 4:** Remove nut securing pulley to blade spindle, and install supplied blower pulley on top of existing pulley. Replace nut, and torque to 70-80 ft-lbs. Replace deck belt onto groove of bottom pulley.

**NOTE:** Nut secures blade bolt in place. Support bolt from beneath while installing pulley.

**IMPORTANT:** Use gloves when working under deck. Sharp blades can cause injury.

**STEP 5:** Set blower against deck discharge. Align holes in blower mount with holes in deck discharge tabs, and secure blower with discharge deflector rod removed in Step 1, securing with pin. **NOTE:** Do not reinstall the deflector spring when installing the rod.

**STEP 6:** Pull back on idler tension release handle, and install blower belt around top groove of deck pulley. **NOTE:** Make sure belt is not rolled or twisted when installing.

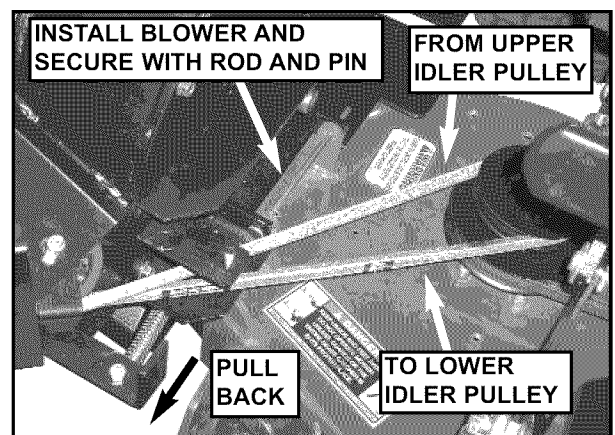
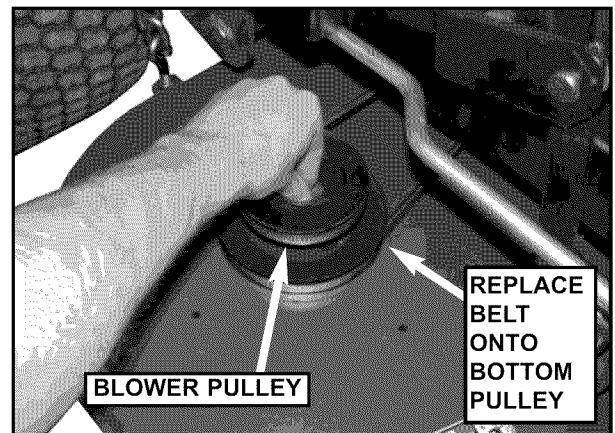
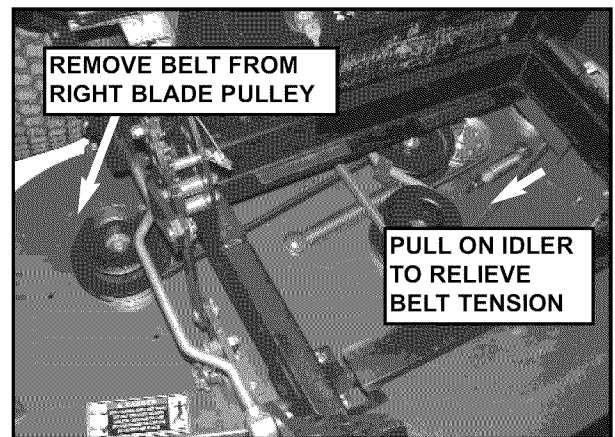
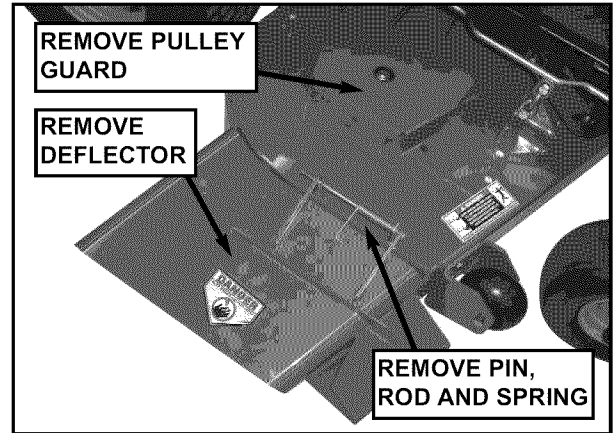

# 3 unit assembly

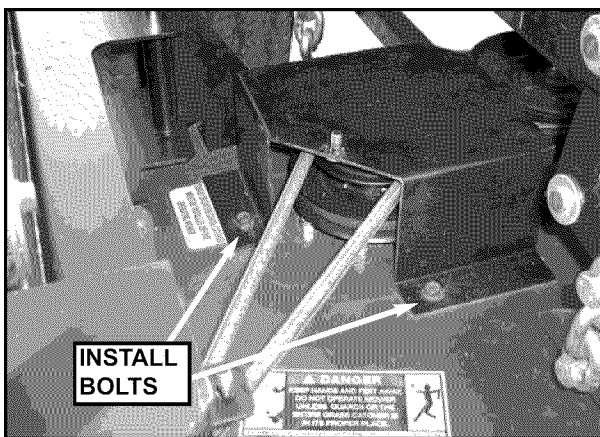
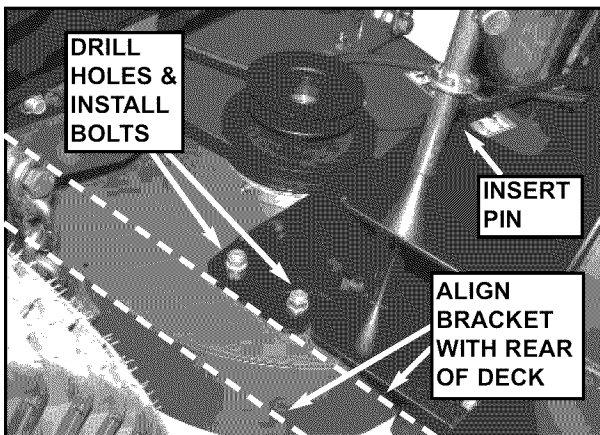
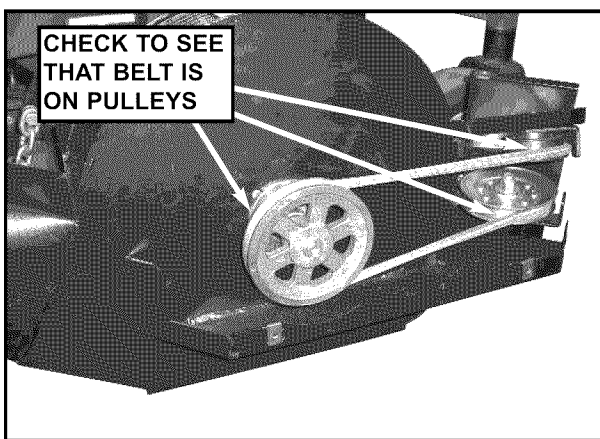
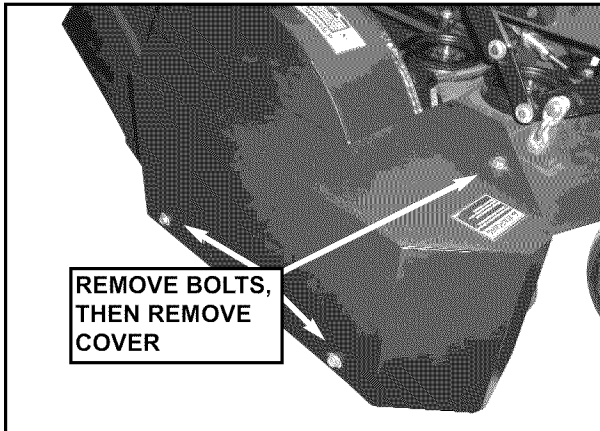

**STEP 6a:** Remove bolts securing impeller pulley cover to blower, and remove cover.

**STEP 6b:** Check to see that blower belt is routed around impeller pulley and idler pulleys after belt is installed onto deck pulley. Replace cover, tightening bolts securely. **IMPORTANT:** Never operate any mower without a pulley guard securely in place.

**STEP 7:** Slip tube of locking pin bracket into blower mount, and secure with T-handle pin, making sure pin goes through both upper and lower holes in blower mount. Then align base of pin bracket parallel with rear of deck, and, using bracket as a template, drill two 7/16" holes through deck. Insert two 3/8-16 x 1" hex bolts up through deck and bracket, securing with hex flange lock nuts. Tighten securely. **IMPORTANT:** Use gloves when working under deck. Sharp blades can cause injury.

**STEP 8:** Lay supplied pulley guard onto deck, aligning holes in guard with holes in deck. Install with bolts securing original guard, tightening securely.

**NOTE:** 48" deck shown; 52" and 61" deck guard configurations may differ.

**STEP 9:** Install belt guard between pulley guard and belt guard support clip on front part of blower mount. Secure with two 5/16 nylon wing nuts. Tighten nuts securely.



## WEIGHT KIT INSTALLATION

**!! Warning:** Weight kit must be installed prior to installing clamshell kit. Failure to do so may result in longitudinal tipping of unit.

**STEP 10:** Lay weight mount channel, with installed weights, across front end of machine as shown. Secure to machine with two clamp plates, one under each caster arm, each held on with two 3/8-16 x 4" hex bolts and lock nuts. See Inset. Tighten securely.

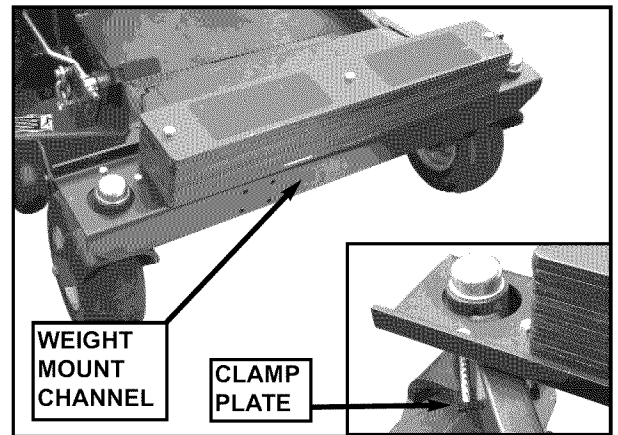

## CLAMSHELL KIT INSTALLATION

**STEP 11:** Install bumper mount standoffs onto rear bumper of machine, utilizing existing hardware on machine. **NOTE:** Invert hardware when installing standoffs, installing bolts out through bumper with nuts facing out.

**NOTE:** When installing standoffs, be sure that the bumper mount plate mounting holes along the back bar of both standoffs are oriented towards the right side of the machine. Refer to the Parts List section of the manual.

**STEP 12:** Install bumper mount plate onto standoffs with four 5/16-18 x 3/4 hex bolts, securing with four 5/16-18 hex flange lock nuts. Tighten securely.

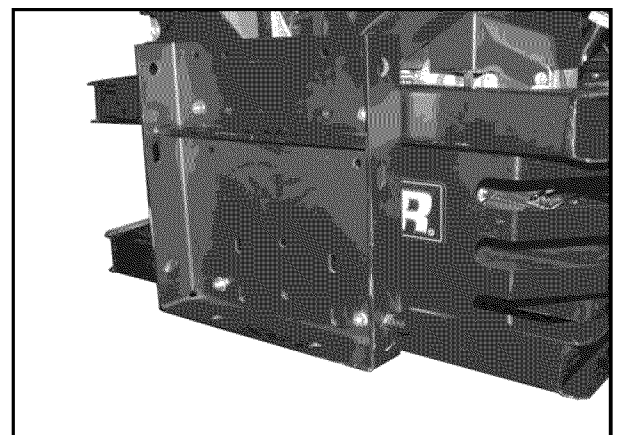
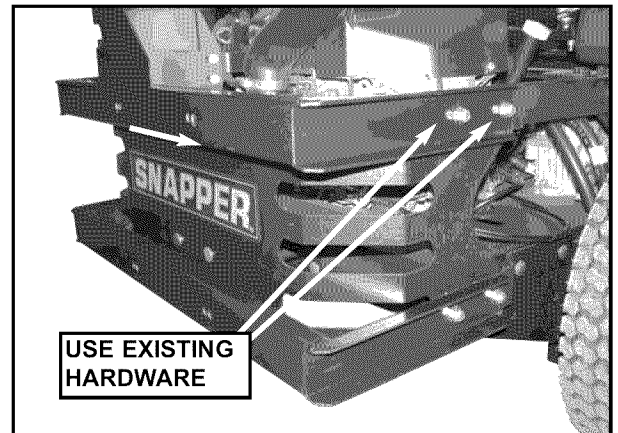

# 3 unit assembly

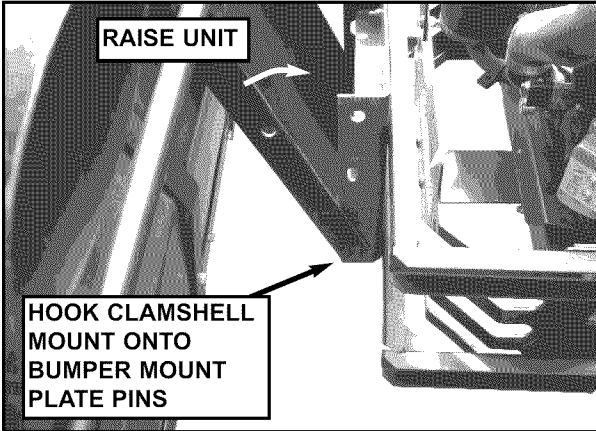

**STEP 13:** Hook bottom of clamshell mount onto pins in bottom of bumper mount plate, then raise clamshell assembly up against bumper mount.

**IMPORTANT:** Assistance is required when installing clamshell unit.

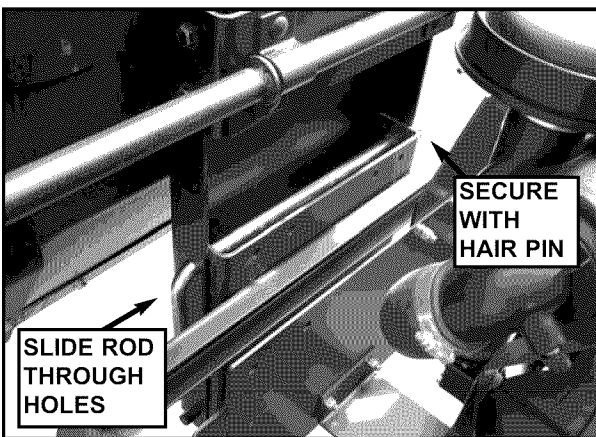

**STEP 14:** Slide hitch rod through aligned holes in clamshell mount and bumper mount plate, securing with hair pin.

**IMPORTANT:** Assistance is required when installing clamshell unit.

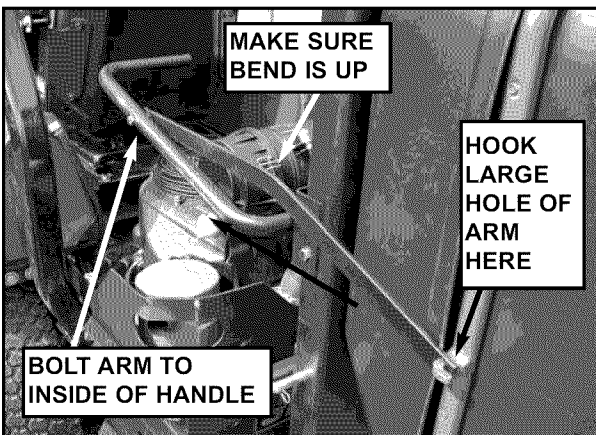

**STEP 15:** Hook the large hole of each actuating arm onto the hook on each side of the rear cover. Then secure the other end of the arm onto the inside of each side of the handle weldment with one 3/8-16 x 2" hex bolt and nyloc nut. Tighten snugly. **NOTE:** Make sure bend of arm is up.

Push handle down to lock cover.

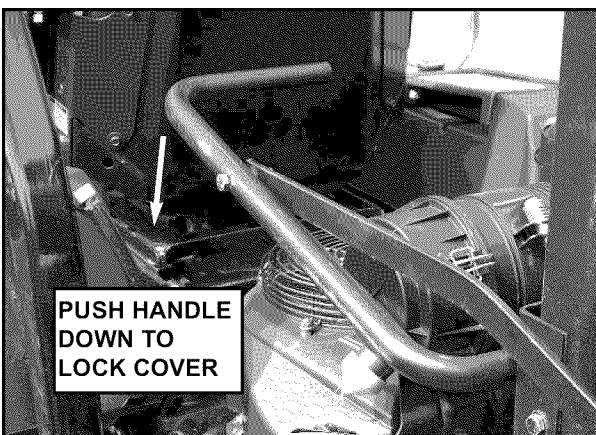



**STEP 16:** Slip one hose clamp onto each side of discharge hose, and install hose between blower and clamshell. **NOTE:** Install hose so that clamp with nut is on the clamshell side, and the clamp with the black quick-release knob is on the blower side. Tighten both clamps securely.

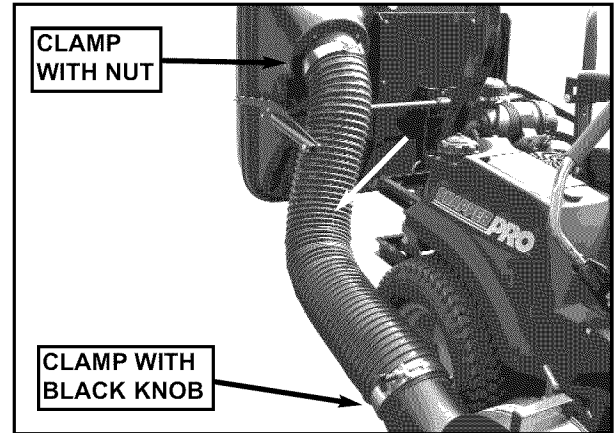

## INTRODUCTION

Follow operation and maintenance instructions in the Operator's Manual provided with the Snapper Mid-Mount Z-Rider.

## GRASS CATCHER OPERATION

1. Select desired cutting height. Choose a setting that will not attempt to cut off too much at once, overloading the machine.
2. After starting engine and allowing a brief warm up period, move engine speed control to highest setting.
3. Drive machine to cutting area. Engage blades.
4. Select a slow forward ground speed until familiar with conditions. Do not select a speed that is too fast, causing the machine to become overloaded.
5. The weight of the grass catcher and contents will affect the stability and handling of the machine. Avoid sudden starts and sharp turns. Reduce speed on slopes, and **DO NOT** operate machine on slopes exceeding 10 degrees (18% grade). Operate machine up and down slopes. **DO NOT** operate machine across the face of slopes. Turn blades off when traveling up slope.
6. Empty grass catcher often to minimize effect on stability and handling. Over filling the catcher will reduce performance and cause clogging of the hose, blower and deck.
7. Do not operate the machine with the Grass Catcher open. The entire Grass Catcher must be installed, the catcher closed and latched properly before operating.

## EMPTYING GRASS CATCHER

1. Empty Grass Catcher often to avoid overfilling. Overfilling reduces performance and causes clogging of hose, blower and deck.
2. Turn blades off. Drive machine to location the clippings are to be dumped. **DO NOT** operate blades in reverse.

If you must back machine to dump clippings in desired location, **LOOK** and **SEE** behind and down for children, pets and hazards before and while backing.

3. Stop motion of machine by returning Motion Control(s) to Neutral (N). Set Park Brake. Stop engine.
4. Lift up on handle sufficiently to allow all clippings to exit catcher. If the dumped pile is too high to allow the catcher to close, you may be required to use a rake or similar implement to distribute the clippings.
5. After dumping, to maintain peak performance, check the catcher screen located on the inside of the Rear Cover Assembly to make sure it is clean and free of any build up. Clean as required with brush or broom.
6. Close catcher. Push down firmly on handle to insure it is properly latched.
7. Re-start engine and drive machine to cutting area. Set engine speed to highest setting, engage blades and resume operation.

⚠

### WARNING

⚠

**DO NOT attempt to remove any clogs from deck, blower, or hose with engine or blade running. STOP engine. STOP blades. Set brake. Remove key. Make sure blades and all rotating components have come to a complete stop before removing any catcher or unclogging any catcher component.**

## IF THE GRASS CATCHER BECOMES CLOGGED

The grass catcher may become plugged if the conditions are too severe, the catcher is overfilled, or the machine is used improperly. If plugging does occur, attempt the following:

1. Engine speed too slow – set engine speed control to “FAST” position.



(Continued On Next Page)



## 4 unit operation & maintenance

### IF THE GRASS CATCHER BECOMES CLOGGED

(Continued From Previous Page)

2. Empty catcher more often.
3. Clean screen on rear cover assembly.
4. Ground speed too fast – cut at slower speed.
5. Removing too much grass – raise cutting height, cut partial width, and cut lawn more frequently.
6. Grass is too wet from rain or dew – allow grass to dry.
7. Blades are dull or worn – inspect blades and replace as necessary. Use only genuine SNAPPER replacement blades.
8. Deck, blower, or hose has clipping build up – clean all clippings from all internal surfaces.

	<b>WARNING</b>	
<b>DO NOT</b> put fingers or hands inside blower! <b>STOP</b> blades. <b>STOP</b> engine. Remove key. Use only a stick, or other suitable means, to clear the blower of clogs or other obstructions!		

	<b>WARNING</b>	
<b>DO NOT</b> attempt any adjustments, maintenance or repairs with engine running. <b>STOP</b> blades. <b>STOP</b> engine. Remove key.		

	<b>WARNING</b>	
Grass Catcher components are subject to deterioration. Inspect frequently. Replace worn or damaged components immediately. Use only genuine SNAPPER replacement parts.		

### To Clear A Plugged Hose

1. Stop blades. Stop engine. Remove key.
2. After all rotating components (engine, blower, blades) have come to a complete stop, loosen hose clamp at outlet of blower, and remove hose from blower.
3. Clear any obstructions from hose. If necessary, use a stick to reach into the hose.
4. Reinstall hose to blower and securely tighten hose clamp.

### To Clear A Plugged Blower

1. Stop blades and blower. Stop engine. Remove key.
2. After all rotating components have come to a complete stop, loosen the hose clamp at the outlet of the blower.
3. Remove hose from blower.
4. Using a stick or similar object, clear all obstructions from blower. **DO NOT INSERT HAND.**
5. Reinstall hose to blower and securely tighten hose clamp.

### GRASS CATCHER MAINTENANCE

Grass Catcher components are subject to wear and deterioration during normal usage. Inspect all components frequently for signs of wear and deterioration. Replace worn or damaged components immediately.

### BEFORE EACH USE

1. Perform pre-start checklist and maintenance as instructed in the SNAPPER Mid-Mount Z-Rider Operator's Manual and Engine Owner's Manual included with the machine.
2. **Clamshell Catcher.** Inspect all catcher components. Replace all worn or damaged parts.
3. **Deck, Blower, Hose.** Clean grass build up from deck, blower, hose, covers and rear cover screen. To maintain peak performance make sure screen is clean at each dumping.
4. **Hose.** Check hose for wear, tears and holes. Replace as needed.
5. **Blades.** Check blades for sharpness, wear, flatness and damage. Refer to MMZ Operator's Manual for blade wear limits and sharpening/replacement instructions.
6. **Blower.** Check blower impeller, blower housing and inlet/outlets for signs of wear and deterioration. Replace as needed. Check all fasteners and hardware to insure none are missing and all are tightened securely. Lubricate impeller shaft bearings with 1 to 3 shots of General Purpose grease from a grease gun.
7. **Belts.** Check belts for wear and fraying. Replace as needed.
8. **Idler Arm.** Check idler arm to insure it pivots freely and bushings are not worn. Replace worn bushings as needed.

## 2 YEAR LIMITED WARRANTY

For two (2) years from purchase date for the original purchaser's residential, non-commercial use, SNAPPER, through any authorized SNAPPER dealer will replace, free of charge (except for taxes where applicable), any part or parts found upon examination by the factory at McDonough, Georgia, to be defective in material or workmanship or both.

For one (1) year from purchase date for the original purchaser's commercial, non-residential use, SNAPPER, through any authorized SNAPPER dealer will replace, free of charge, any part or parts found upon examination by the factory at McDonough, Georgia, to be defective in material or workmanship or both.

For ninety (90) days from purchase date for the original purchaser's rental use, SNAPPER, through any authorized SNAPPER dealer will replace, free of charge, any part or parts found upon examination by the factory at McDonough, Georgia, to be defective in material or workmanship or both

All transportation costs incurred by the purchaser in submitting material to an authorized SNAPPER dealer for replacement under this warranty must be paid by the purchaser.

This warranty does not apply to certain transmissions, to engines and their components, and batteries, as these items are warranted separately. This warranty does not apply to parts that have been damaged by accident, alteration, abuse, improper lubrication, normal wear, or other cause beyond the control of SNAPPER. This warranty does not cover any machine or component part that has been altered or modified changing safety, performance, or durability.

Batteries have a one (1) year warranty period with free replacement if required for one (1) year from the original purchase date. SNAPPER will not be responsible for any installation cost incurred. The battery warranty only covers original equipment batteries and does not cover damage to the battery or machine caused by neglect or abuse, destruction by fire, explosion, freezing, overcharging, improper maintenance, or use of improper electrolyte.

There is no other express warranty.

### DISCLAIMER OF WARRANTY

Implied warranties, including those of merchantability and fitness for a particular purpose, are limited to two (2) years from purchase date for the original purchaser's residential or other non-commercial use, and one (1) year from purchase for the original purchaser's commercial, non-residential use, and ninety (90) days from purchase for the original purchaser's rental use and to the extent permitted by law, any and all implied warranties are excluded. This is the exclusive remedy. Liabilities for consequential damages, under any and all warranties are excluded.

Some states do not allow limitations on how long an implied warranty lasts, or do not allow the exclusion or limitation of incidental or consequential damages, so the above limitation or exclusion may not apply to you.

This warranty gives you specific legal rights, and you may also have other rights which vary from state to state.

**WARNING: THE USE OF REPLACEMENT PARTS OTHER THAN GENUINE SNAPPER PARTS MAY IMPAIR THE SAFETY OF SNAPPER PRODUCTS AND WILL VOID ANY LIABILITY AND WARRANTY BY SNAPPER ASSOCIATED WITH THE USE OF SUCH PARTS.**

**IMPORTANT:** Please fill out the SNAPPER Product Registration Card immediately and mail to:  
Snapper's Product Registration Center, P.O. Box 1379, McDonough, Georgia 30253

# 6 unit breakdown & parts list

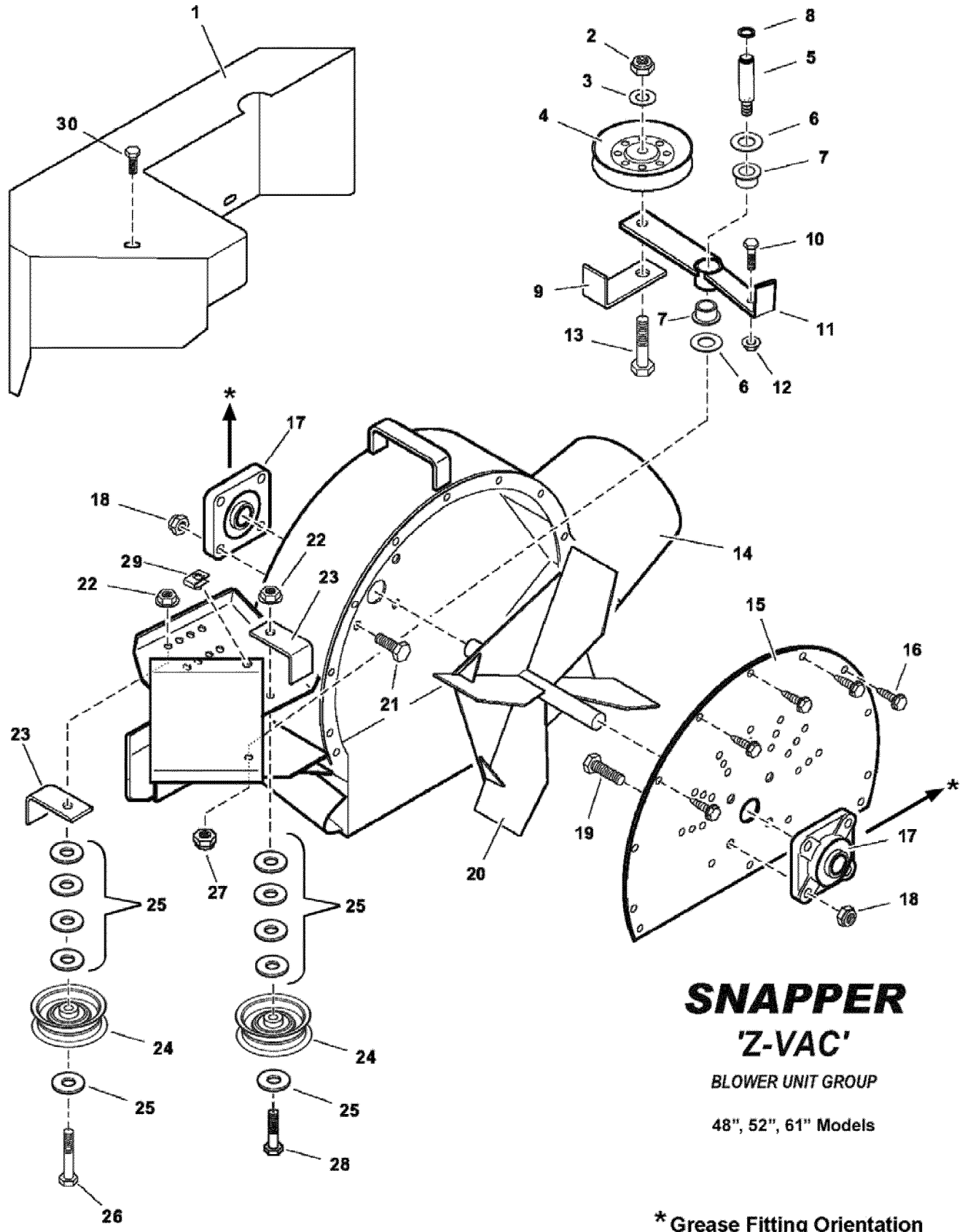

## SNAPPER 'Z-VAC'

BLOWER UNIT GROUP

48", 52", 61" Models

\* Grease Fitting Orientation

**Snapper Z-Vac Blower Unit Group 48", 52", 61" Models**

Item	Part No.	Qty	Description
1	3046782	1	WELDMENT, Blower Belt Guard
2	91121	1	NUT, 1/2-13 Hex Nyloc
3	90183	1	WASHER, 1/2" Flat SAE
4	3021097	1	PULLEY, A Groove Idler, Steel
5	44995	1	IDLER STUD (3/8-24 thread)
6	91804	2	FLAT WASHER, 9/16 Type Narrow
7	14409	2	FLANGE BEARING, 9/16" I.D. (powdered metal)
8	10776	1	RETAINING RING, 1/2"
9	3046824	1	BELT RETAINER, Idler
10	91527	1	SCREW, 5/16-18 x 1-1/4" Hex Head Cap, GR5
11	3047253	1	WELDMENT, Idler Arm
12	91601	1	NUT, 5/16-18 Hex Flange Lock
13	91218	1	SCREW, 1/2-13 x 2-1/2" Hex Head Cap, GR5
14	3046781	1	WELDMENT, Blower Housing
15	3046853	1	BACK PLATE, Blower
16	91541	7	SCREW, 5/16-18 x 3/4" Hex Washer Self-Tap
17	3022832	2	BEARING, Pillow Block, Blower (includes grease fitting)
18	90839	8	NUT, 7/16-14 Hex Center Lock, GR5 or B
19	3031920	4	SCREW, 7/16-14 x 1-1/2" Hex Head Cap, GR5
20	3046854	1	IMPELLER, Fast Vac Blower (weldment)
21	3031919	4	SCREW, 7/16-14 x 1-1/4" Hex Head Cap, GR5
22	90613	2	NUT, 3/8-16 Hex Flange Lock
23	3046813	2	BELT RETAINER
24	3043613	2	PULLEY, Flat Idler, 2-3/4" O.D.
25	90122	9	WASHER, 3/8" Flat SAE
26	91560	1	SCREW, 3/8-16 x 2-1/4" Hex Head Cap, GR5
27	91518	1	NUT, 3/8-24 Hex Nyloc
28	91305	1	SCREW, 3/8-16 x 2" Hex Head Cap, GR5
29	92111	3	U-CLIP, 5/16-18
30	91541	3	SCREW, 5/16-18 x 3/4" Hex Washer Self-Tap

# 6 unit breakdown & parts list

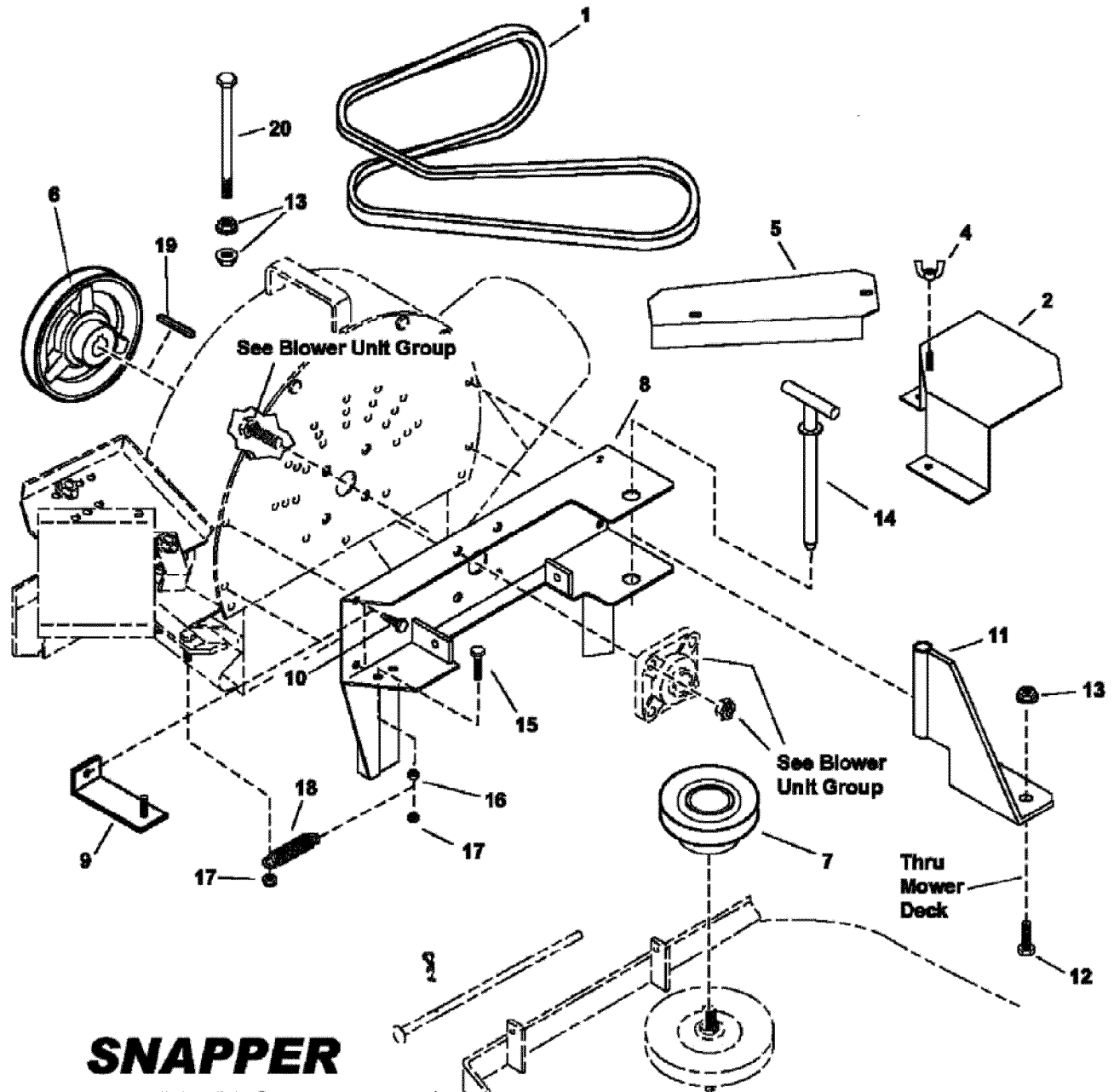

## **SNAPPER 'Z-VAC'**

**BLOWER MOUNT GROUP**

48", 52", 61" Models

**Snapper Z-Vac Blower Mount Group 48", 52", 61" Models**

Item	Part No.	Qty	Description
1	3036323	1	BELT, A Section, 91.125" effective length (used on 48" & 52" Models)
1	3022844	1	BELT, A Section, 92.0" effective length (used on 61" Models)
2	3037161	1	WELDMENT, Belt Cover, Deck (used on 48" & 52" Models)
2	33867	1	WELDMENT, Belt Cover, Deck (used on 61" Models)
3	----	--	NOT USED
4	91537	2	WING LOCKNUT 5/16-18
5	3037162	1	BELT GUARD, 48" Deck
5	3037163	1	BELT GUARD, 52" Deck
5	33847	1	BELT GUARD, 61" Deck
6	3046806	1	PULLEY, Blower Input, 48" & 52"
6	3046809	1	PULLEY, Blower Input, 61"
7	3036324	1	PULLEY, 48"/52" Spindle
8	3027505	1	WELDMENT, 48" Blower Mount
8	3027506	1	WELDMENT, 52" Blower Mount
8	33873	1	WELDMENT, 61" Blower Mount
9	3027507	1	WELDMENT, Guard Support Bracket
10	91541	4	SCREW, 5/16-18 x 3/4" Hex Washer Self-Tap
11	3027508	1	WELDMENT, Deck Mount Bracket
12	91304	2	SCREW, 3/8-16 x 1" Hex Head Cap, GR5
13	90613	4	NUT, 3/8-16 Hex Flange Lock
14	3032118	1	WELDMENT, T-Handle Pin
15	91527	1	SCREW, 5/16-18 x 1-1/4" Hex Head Cap, GR5
16	91601	1	NUT, 5/16-18 Hex Flange Lock
17	90951	2	NUT, 5/16-18 Hex Large Flange Center Lock
18	3020807	1	SPRING, Idler, Fast Vac
19	12315	1	KEY, 1/4 Square x 1.44
20	91617	1	SCREW, 3/8-16 x 6" Hex Head Cap, GR5
--	33740	1	BRACKET, Spring (Not Shown; used on 61" Models)
--	33868	1	WELDMENT, Spring Bracket (Not Shown; used on 61" Models)

# 6 unit breakdown & parts list

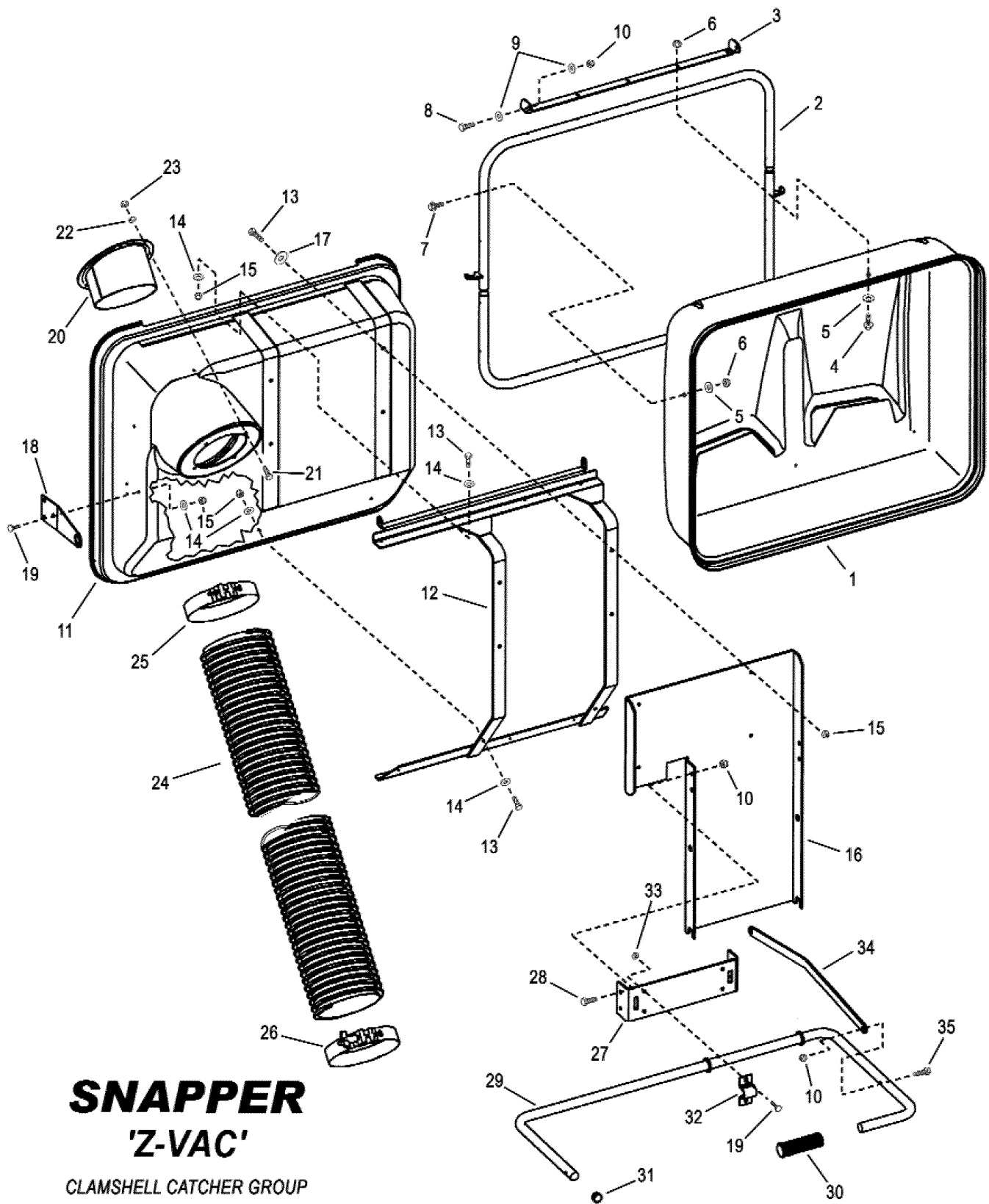

## **SNAPPER** **'Z-VAC'**

CLAMSHELL CATCHER GROUP



**Snapper Z-Vac Clamshell Catcher Group**

Item	Part No.	Qty	Description
1	72979	1	COVER, Rear, Clamshell Bagger
--	73509	1	SCREEN, Clamshell (Not Shown)
--	73525	8	RIVET, 5/32 (Not Shown)
2	58600	1	WELDMENT, Rear Cover Brace
3	73179	1	HINGE, Rear Cover
4	91265	5	SCREW, #10-24 x 1-1/2" Hex Washer Machine
5	36422	18	WASHER, .190 ID x .75 OD Flat
6	91079	18	NUT, 10-24 Hex Flange Lock
7	73145	13	BOLT, #10-24 x 1-1/2" Oval Head
8	91304	2	SCREW, 3/8-16 x 1" Hex Head Cap, GR5
9	91514	4	WASHER, .40 ID x .81 OD Flat
10	91299	8	NUT, 3/8-16 Nyloc
11	73181	1	COVER, Front, Clamshell Bagger
--	72874	1	DEFLECTOR, Clamshell Bagger (Not Shown)
--	91631	2	SCREW, #10-24 x 1/2" Hex Head Machine (Not Shown)
--	36422	2	WASHER, .190 ID x .75 OD Flat (Not Shown)
--	91079	2	NUT, 10-24 Hex Flange Lock (Not Shown)
12	43333	1	BRACE, Front Cover Weldment
13	91527	13	SCREW, 5/16-18 x 1-1/4" Hex Head Cap, GR5
14	91528	21	WASHER, .375 ID x .875 OD Flat
15	91298	16	NUT, 5/16-18 Nyloc
16	11292	1	MOUNT, Clamshell
17	16314	4	WASHER, .33 ID x 1.25 OD Flat
18	11296	1	HANDLE BRACE, Clamshell
19	91303	7	BOLT, 5/16-18 x 1" Carriage
20	43334	1	TUBE ADAPTER WELDMENT
21	91814	4	SCREW, 1/4-20 x 1-1/4" Hex Head Cap, GR5
22	91315	4	WASHER, 1/4" Split Lock
23	91576	4	NUT, 1/4-20 Hex
24	3022833	1	HOSE, Snapper Fast Vac
25	3022875	1	HOSE CLAMP, Upper
26	3022876	1	HOSE CLAMP, Lower
27	11293	1	BRACKET, Handle Mount
28	27198	4	BOLT, 3/8-16 x 1" Hex Flange
29	43332	1	HANDLE WELDMENT
30	11870	1	GRIP
31	72951	1	ENDCAP, Tube
32	43803	2	BRACKET, Hanger
33	91601	4	NUT, 5/16-18 Hex Flange Lock
34	11295	2	ARM, Clamshell Actuating
35	91305	2	SCREW, 3/8-16 x 2" Hex Head Cap, GR5

# 6 unit breakdown & parts list

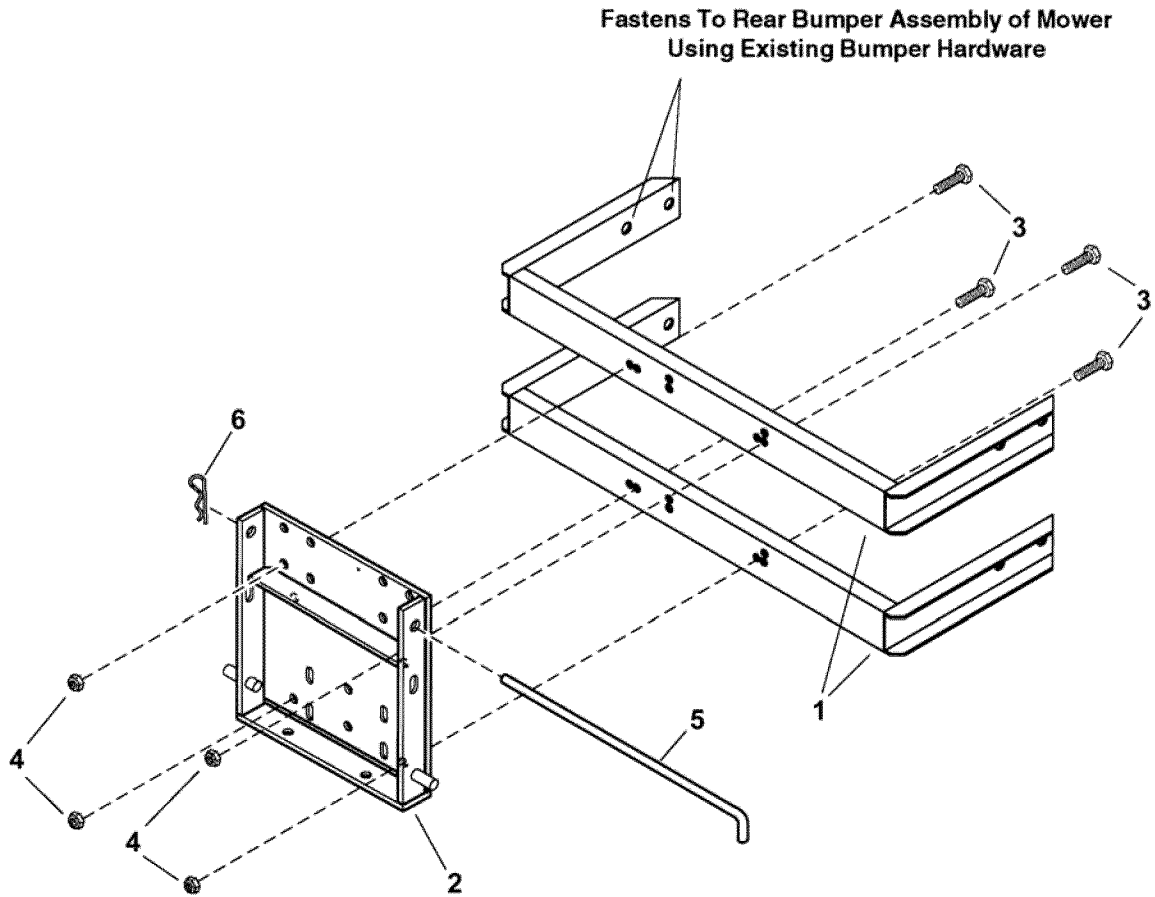

## **SNAPPER** **'Z-VAC'**

CLAMSHELL CATCHER MOUNT GROUP

***Snapper Z-Vac Clamshell Catcher Mount Group***

<b>Item</b>	<b>Part No.</b>	<b>Qty</b>	<b>Description</b>
1	50551	2	STANDOFF, Bumper Mount (weldment)
2	1723436	1	WELDMENT, Bumper Mount Plate
3	91318	4	SCREW, 5/16-18 x 3/4" Hex Head Cap, GR5
4	91601	4	NUT, 5/16-18 Hex Flange Lock, GR5
5	1717085	1	ROD, Hitch
6	15067	1	HAIR PIN, 3/32 x 1-1/2" Cotter

# 6 unit breakdown & parts list

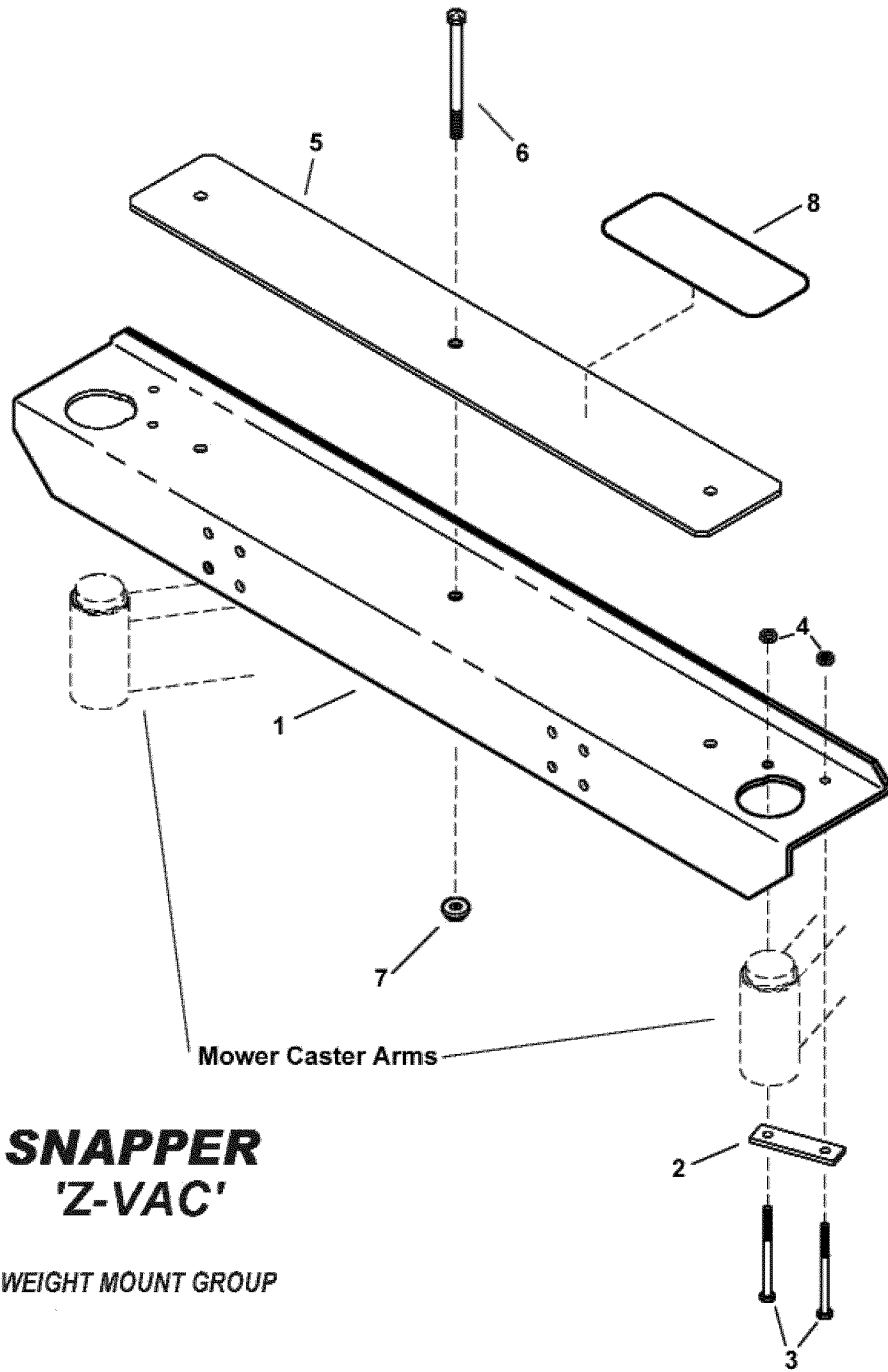

**Snapper Z-Vac Weight Mount Group**

<b>Item</b>	<b>Part No.</b>	<b>Qty</b>	<b>Description</b>
1	3027501	1	CHANNEL, Weight Mounting
2	3046992	2	BAR, Clamp
3	91131	4	BOLT, 3/8-16 x 4" Hex Tap, GR5
4	90546	4	NUT, 3/8-16 Hex Center Lock, GR5 or B
5	3027502	13	BAR, Weight
6	3031021	3	SCREW, 1/2-13 x 4-1/2" Hex Head Cap
7	90619	3	NUT, 1/2-13 Hex Flange Lock
8	3032142	2	PAD, Anti-Skid, Self-Adhesive

# 6 unit breakdown & parts list

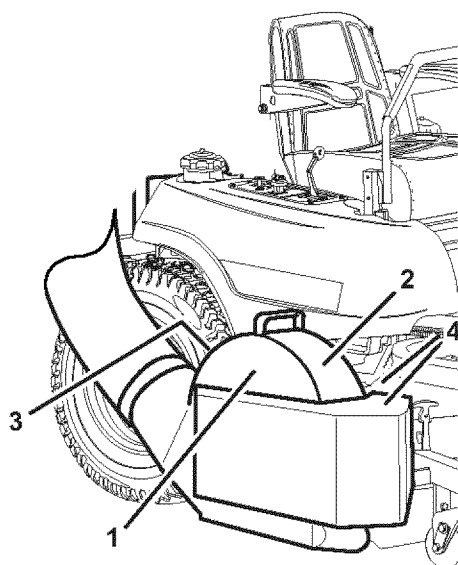

1

2

3

4

5  
(on clamshell unit)

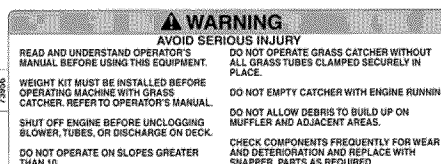
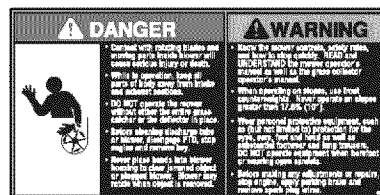

**NOTE:**  
Decals are not to scale.

***Snapper Z-Vac Decal Group***

<b>Item</b>	<b>Part No.</b>	<b>Qty</b>	<b>Description</b>
1	3079231	1	DECAL, Z-Vac
2	3046850	1	DECAL, Danger, Fast-Vac
3	3046851	1	DECAL, Warning, Fast Vac
4	3046883	1	DECAL, Warning, Fast-Vac
5	73956	1	DECAL, Warning, Billboard (on clamshell unit)

# **SNAPPER®**

**ASSEMBLY INSTRUCTIONS**  
**OPERATOR'S MANUAL**  
**PARTS LIST**

## **Z-VAC**

**Clamshell**  
**Grass Catcher Kit**  
**for NZM**  
**Mid Mount**  
**Riders**

# **SNAPPER®**

McDonough, GA 30253 U.S.A.

Manual No. 7011299 (I.R. 03/11/05)