

Safety Instructions & Operator's Manual for **SNAPPER**[®]

MID MOUNT Z-RIDER ZERO TURNING HYDRO DRIVE SERIES 1

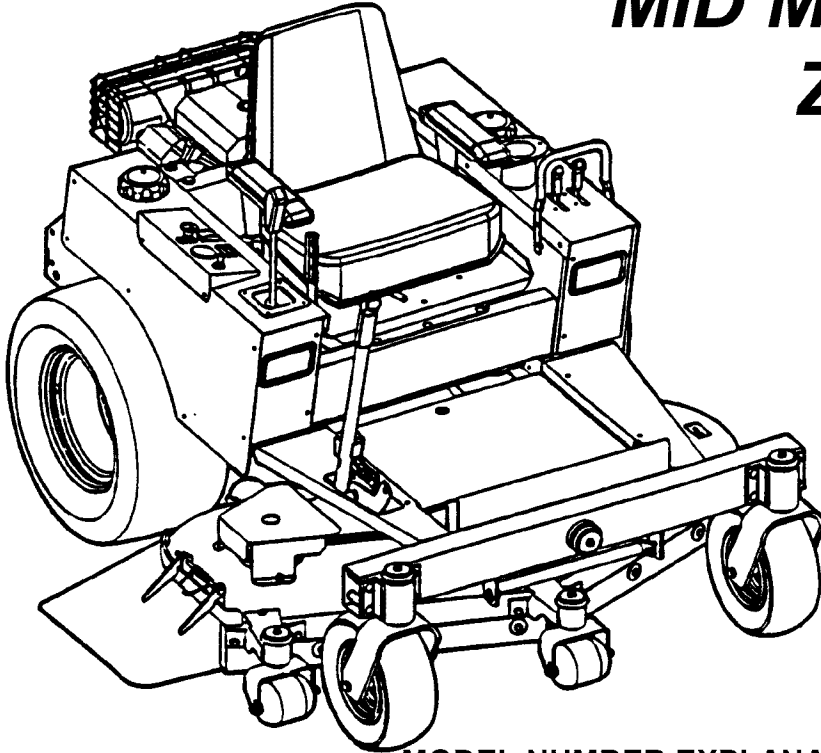

POWER UNIT MODELS	
ZM2501KH	

MOWER UNIT MODELS	
ZM5201M	ZM6101M

MODEL NUMBER EXPLANATION

<table border="1" style="margin: auto;"> <tr> <td style="padding: 5px;">Z</td> <td style="padding: 5px;">M</td> <td style="padding: 5px;">25</td> <td style="padding: 5px;">01</td> <td style="padding: 5px;">KH</td> </tr> </table>		Z	M	25	01	KH
Z	M	25	01	KH		
DRIVE SYSTEM TYPE				ENGINE TYPE		
MOWER ORIENTATION				SERIES DESIGNATION		
				ENGINE HP		
POWER UNIT						
Z – Zero Turning – Hydro Drive	25 – Engine Horse Power	01 – Series Designation	KH – Kohler Engine			
M – Mid Mount Mower						
MOWER UNIT						
Z – Zero Turning – Hydro Drive	52 – Mower Cutting Width	01 – Series Designation	M – Mower Deck			
M – Mid Mount Mower	61 – Mower Cutting Width					

Thank you for buying a SNAPPER Product! Before operating your machine, read this manual carefully and pay particular attention to the "IMPORTANT SAFETY INSTRUCTIONS" on Pages 2 - 4. Remember that all power equipment can be dangerous if used improperly. Also keep in mind that SAFETY requires careful use in accordance with the operating instructions and common sense!

SNAPPER McDonough, GA., 30253 U.S.A.



IMPORTANT SAFETY INSTRUCTIONS



WARNING: This powerful cutting machine is capable of amputating hands and feet and can throw objects that can cause injury and damage! Failure to comply with the following **SAFETY** instructions could result in serious injury or death to the operator or other persons. The owner of the machine must understand these instructions and must allow only persons who understand these instructions to operate machine. Each person operating the machine must be of sound mind and body and must not be under the influence of any substance, which might impair vision, dexterity or judgment. If you have any questions pertaining to your machine which your dealer cannot answer to your satisfaction, call or write the Customer Service Department at SNAPPER, McDonough, Georgia 30253. Phone: (1-800-935-2967).

PROTECTION FOR CHILDREN

Tragic accidents can occur if the operator is not alert to the presence of children. Children are often attracted to the machine and the mowing activity. Never assume that children will remain where you last saw them.

1. **KEEP** children out of the mowing area and under the watchful care of a responsible adult.
2. **DO NOT** allow children in yard when machine is operated (even with the blades **OFF**).
3. **DO NOT** allow children or others to ride on machine or on attachments (even with the blade **OFF**). They may fall and be seriously injured.
4. **DO NOT** allow pre-teenage children to operate machine. Local regulations may restrict the age of the operator.
5. **ALLOW** only adults or responsible teenagers with mature judgment under close adult supervision to operate machine.
6. **DO NOT** operate blades in reverse. **STOP BLADES.** **LOOK** and **SEE** behind and down for children, pets and hazards before and while backing.
7. **USE EXTRA CARE** when approaching blind corners, shrubs, trees, or other objects that may obscure vision.

PROTECTION AGAINST TIPOVERS

Slopes are a major factor related to loss-of-control and tip-over accidents, which can result in severe injury or death. All slopes require extra **CAUTION**. If you cannot back up the slope or if you feel uneasy on the slope, **DO NOT** mow it. Use extra care with grass catchers or other attachments; these and turf conditions affect the handling and the stability of the machine.

1. **DO NOT** operate machine on slopes exceeding 15 degrees (27% grade).
2. Exercise **EXTREME CAUTION** on slopes above 10 degrees (18% grade). Turn blades **OFF** when traveling uphill. Use a slow speed and avoid sudden or sharp turns.
3. **DO NOT** operate machine back and forth across face of slopes. Operate up and down. Practice on slopes with blades off.
4. **AVOID** uphill starts. If machine stops going uphill or tires lose traction, turn blades **OFF** and back slowly down the slope.

PROTECTION AGAINST TIPOVERS

(Continued From Previous Column)

5. **STAY ALERT** for holes and other hidden hazards. Tall grass can hide obstacles. Keep away from ditches, washouts, culverts, fences and protruding objects.
6. **DO NOT** operate machine near drop offs, ditches, embankments, washouts, culverts, fences and protruding objects. **KEEP A SAFE DISTANCE** (at least 3 feet) away from edge of ditches and other drop offs. The machine could turn over if an edge caves in.
7. Always begin forward motion slowly and with caution.
8. Use weights or a weighted load carrier in accordance with instructions supplied with a grass catcher. **DO NOT** operate machine on slopes exceeding 10 degrees (18% grade) when equipped with grass catcher.
9. **DO NOT** put your foot on the ground to try to stabilize the machine.
10. **DO NOT** operate machine on wet grass. Reduced traction could cause sliding.
11. **DO NOT** operate machine under any condition where traction, steering or stability is doubtful.
12. Operator Protective Structures are available for this machine through your local SNAPPER dealer.

PREPARATION

1. Read, understand and follow instructions and warnings in this manual and on the machine, engine and attachments. Know the controls, the safety signs and the proper use of the machine before starting. If the operators or mechanics cannot read English, it is the owner's responsibility to explain this material to them.
2. Only mature, responsible persons shall operate or service the machine and only after proper instruction and training. The owner is responsible for training the operators. Further, the owner/operator can prevent and/or is responsible for accidents or injuries occurring to themselves, other people or property.
3. Data indicates that operators age 60 and above, are involved in a large percentage of mower-related injuries. These operators should evaluate their ability to operate the mower safely enough to protect themselves and others from serious injury.



IMPORTANT SAFETY INSTRUCTIONS



PREPARATION

(Continued From Previous Page)

4. Handle fuel with extra care. Fuels are flammable and vapors are explosive. Use only an approved fuel container. DO NOT remove fuel cap or add fuel with engine running. Add or drain fuel outdoors only with engine stopped and cool. Clean spilled fuel from machine. DO NOT smoke.
5. Practice operation of machine with **BLADES OFF** to learn controls and develop skills.
6. Check the area to be mowed and remove all objects such as toys, wire, rocks, limbs and other objects that could cause injury if thrown by blades or interfere with mowing.
7. Evaluate the terrain to determine what accessories and attachments are needed to properly and safely perform the job. Only use accessories and attachments approved by SNAPPER.
8. Keep people and pets out of mowing area. Immediately, STOP blades, STOP engine, and STOP machine if anyone enters the area.
9. DO NOT operate machine unless all shields, deflectors, switches, blade controls and other safety devices are in place and functioning properly.
10. Make sure all safety decals are clearly legible. Replace if damaged.
11. Protect yourself when mowing and wear appropriate clothing including safety glasses, long pants, ear protection, hardhat and substantial footwear with good traction. Long hair, loose clothing or jewelry may get tangled in moving parts.
12. Know how to STOP blades and engine quickly in preparation for emergencies.
13. Use extra care when loading or unloading the machine into a trailer or truck.
14. Check grass catcher components frequently for signs of wear or deterioration and replace as needed to prevent injury from thrown objects going through weak or worn spots.

OPERATION

1. Mount and dismount machine from left side.
2. Start engine from operator's seat. Make sure blades are OFF and parking brake is set. Use seat belts if provided.
3. DO NOT leave machine with engine running. Stop engine. Stop blades. Set brake. Remove key.
4. DO NOT operate machine unless properly seated with feet on foot rests or pedal(s).
5. DO NOT operate machine while under the influence of alcohol or drugs.

OPERATION

(Continued From Previous Column)

6. STOP MACHINE on level ground, lower deck, engage parking brake and make sure engine and blades have stopped before removing grass catcher or unclogging mower to prevent injury to hands or feet.
7. Blades must be OFF except when cutting grass. Set blades in highest position when mowing over rough ground.
8. Keep hands and feet away from rotating blades underneath deck. DO NOT place foot on ground while **BLADES** are ON or machine is in motion.
9. DO NOT operate machine without entire grass catcher or guards in place. DO NOT point discharge at people, passing cars, windows or doors.
10. Slow down before turning.
11. Watch out for traffic when near or crossing roadways.
12. STOP engine immediately after striking an object or if an abnormal vibration occurs. Remove key. Remove and disconnect the sparkplug wire. Make necessary repairs before resuming operation.
13. Mow only in daylight or with good artificial light.
14. Move motion control levers SLOWLY to maintain control during speed and directional changes.
15. Exercise CAUTION when pulling loads. DO NOT pull loads greater than 300 pounds. Avoid jackknifing. DO NOT turn sharply.
16. DO NOT operate engine in enclosed areas. Engine exhaust gases contain carbon monoxide, an odorless and deadly poison.

MAINTENANCE

1. DO NOT store machine or fuel container inside where fumes may reach an open flame, spark or pilot light such as in a water heater, furnace, clothes dryer or other gas appliance. Allow engine to cool before storing machine in an enclosure. Store fuel container out of the reach of children in a well ventilated, unoccupied building. Shut off fuel (when equipped with valve) while storing or transporting machine.
2. Clean grass and debris from engine, mufflers, drives and cutting units to help prevent overheating and fires. Clean up fuel, oil and excess grease.
3. When draining fuel tank, drain fuel into an approved container outdoors and away from open flame.
4. Check brakes frequently; adjust, repair or replace as needed.
5. Keep all bolts, nuts and screws properly tight. Check that all cotter pins are in proper position.
6. Always provide adequate ventilation when running engine. Engine exhaust gases contain carbon monoxide, an odorless and deadly poison.



IMPORTANT SAFETY INSTRUCTIONS



MAINTENANCE

(Continued From Previous Page)

7. Disconnect battery before performing maintenance or service. Cranking engine could cause injury. Disconnect negative (black) cable from battery first and positive (red) cable last. Reconnect positive first and negative last. Charge battery in an open, well ventilated area away from spark and flames. Unplug charger before connecting or disconnecting from battery. Wear protective clothing and insulated gloves.
8. Park machine on level ground. DO NOT work under machine without safety blocks.
9. Service engine and clean, adjust or repair only when engine and blades are stopped. Remove spark plug wire(s) from spark plug(s) and secure wire(s) away from spark plug(s).
10. DO NOT change engine governor speed settings or overspeed engine. DO NOT make adjustments with the engine running.
11. Lubricate machine at intervals specified in manual to prevent controls from binding.
12. Mower blades are sharp and can cut. Wrap the blades or wear heavy leather gloves and use CAUTION when handling them. Never straighten or weld blades, only replace them.
13. DO NOT test for spark by grounding spark plug next to spark plug hole; spark plug could ignite gas exiting engine.
14. Carefully release pressure from components with stored energy.
15. Have machine serviced by an authorized SNAPPER dealer at least once a year and have the dealer install any new safety devices. Never allow untrained personnel to service machine.
16. Use only genuine SNAPPER replacement parts to assure that original standards are maintained.

TABLE OF CONTENTS

IMPORTANT SAFETY INSTRUCTIONS	2-4
TABLE OF CONTENTS	5
SECTION 1 – FAMILIARIZATION	6
SECTION 2 – SAFETY MESSAGES AND SYMBOLS	7-8
SECTION 3 - OPERATING INSTRUCTIONS	9-12
Pre-start Checklist	9
Starting & Stopping Engine.....	10
Starting & Stopping Mower Blades	10
Parking Brake	11
Adjusting Cutting Height	12
Driving & Stopping Machine	12
SECTION 4 - MAINTENANCE INSTRUCTIONS	13-17
Change Engine Oil.....	13
Check Mower Blade	13
Check Mower Drive Belt	14
Check Belt Tension	14
Service – After every 25 Hours (Engine Components).....	14
Service – After every 25 Hours (Mower Components).....	14
Lubrication	14-15
Mower Blade Spindle Lubrication	14
Mower Deck Linkage Lubrication	14
Front Wheel Bearings Lubrication	15
Transaxle Lubrication	15
Power Transfer Shaft Lubrication.....	15
Other Lubrication.....	15
Before Operating Machine.....	15
Annually - End of Season	15-16
Engine Service.....	15
Fuel Filter Replacement	16
Deck Removal	16-17
Power Transfer Shaft Removal	17
SECTION 5 - ADJUSTMENTS AND REPAIR	18-23
Neutral Position Adjustments	18
Mower Deck Adjustment (Levelness).....	18-19
Parking Brake Adjustment.....	20
Engine Adjustments & Repair.....	20
Mower Blade Replacement	20-21
Mower Drive Belt Removal & Replacement	21
Battery Removal	22
Battery Installation	22
Battery Service & Charging	22
Battery Testing.....	23
New Battery Preparation.....	23
TROUBLESHOOTING	24-25
SERVICE SCHEDULE	26
Maintenance/Replacement Parts	26
WARRANTY	27
PRIMARY MAINTENANCE	28-31

IMPORTANT

NOTICE: Operator Protective Structures are available as optional kits for the Mid-Mount and Out-Front Z-Rider machines. These structures, when installed and used properly can offer additional security to the operator against serious injury in the event of a tip over accident. Operator Protective Structures may be required by local ordinances. Discuss your mowing application and ordinances with your local Snapper Dealer.

Section 1 - FAMILIARIZATION

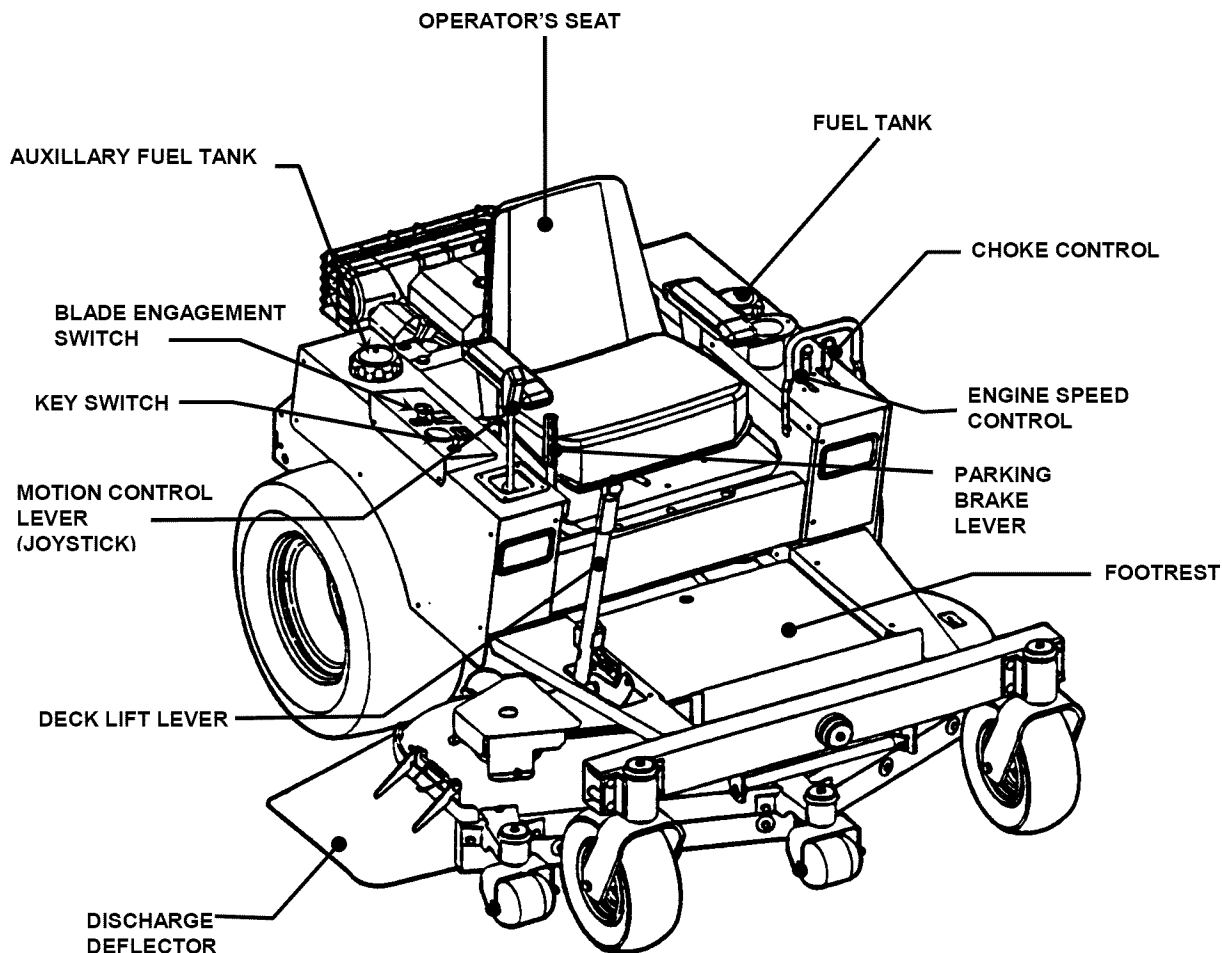

FIGURE 1.1

1.1 INTRODUCTION

This manual has been prepared for the operator's of the SNAPPER MID MOUNT Z-RIDER. Its purpose, aside from recommending standard operating procedures and routine service requirements, is to promote SAFETY through the use of accepted operating practices. Read, Understand and Follow the IMPORTANT SAFETY INSTRUCTIONS on Pages 2 thru 4 of this manual and All SAFETY messages on the MID MOUNT Z-RIDER and its attachments before operating. SNAPPER recommends returning the MID MOUNT Z-RIDER to an authorized SNAPPER dealer annually for inspection and addition of any new devices which might upgrade the safety of the mower.

1.2 NOMENCLATURE

The nomenclature information above, Figure 1.1, shows the essential parts of the SNAPPER MID MOUNT Z-RIDER. It is recommended that all operator's of this equipment become thoroughly familiar with the controls, components, and operation of this machine before operating. Specific details involving the engine are found in the separate engine owner's manual. Study these manuals before operating and keep both handy for future reference. For the nearest SNAPPER dealer in your area, check the yellow pages under the heading LAWN MOWERS. For engine parts and service, look for the engine manufacturer's dealers under the heading, ENGINES - gasoline.

Section 2 – SAFETY MESSAGES AND SYMBOLS



WARNING

TO AVOID SERIOUS INJURY OR DEATH

- READ OPERATOR'S MANUAL AND OTHER INSTRUCTIONAL MATERIALS PROVIDED.
- KNOW LOCATION AND FUNCTION OF ALL CONTROLS.
- NEVER START BLADES UNLESS PROPERLY SEATED ON MACHINE.
- KEEP SAFETY DEVICES (GUARDS, SHIELDS AND SWITCHES) IN PLACE.
- REMOVE OBJECTS THAT COULD BE THROWN BY THE BLADES.
- DO NOT MOVE MOTION CONTROL LEVERS RAPIDLY. AVOID SUDDEN TURNS.
- DO NOT OPERATE BLADES IN REVERSE.
- LOOK DOWN AND BEHIND BEFORE AND DURING REVERSE MOVEMENT.
- DO NOT MOW IN ANY AREA WHERE STABILITY AND TRACTION IS IN DOUBT. DO NOT MOW ON SLOPES STEEPER THAN 15°.
- REDUCE SPEED ON SLOPES. GO FORWARD DOWN SLOPES. GO REVERSE UP SLOPES. NEVER TRAVEL ACROSS SLOPES.
- AVOID UPHILL STARTS. IF MACHINE STOPS GOING UPHILL, STOP BLADES AND BACK DOWN SLOWLY.
- DO NOT MOW WHEN CHILDREN OR OTHERS ARE AROUND. NEVER CARRY CHILDREN DURING OPERATION EVEN WITH BLADES OFF.
- BE SURE ALL MOVING PARTS ARE STATIONARY BEFORE PLACING HANDS AND FEET NEAR BLADES OR SERVICING MACHINE.

CHOKE
"ON"



ENGINE CONTROLS





RABBIT
"FAST"

CHOKE

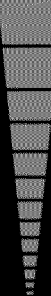

ENGINE
SPEED

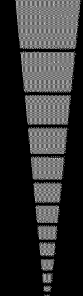

CHOKE
"OFF"





TURTLE
"SLOW"

TO START:
 MAKE SURE OPERATOR IS SEATED PROPERLY.
 PLACE MOTION CONTROL LEVERS IN CENTER/NEUTRAL POSITION.
 PULL UP ON BRAKE LEVER TO SET BRAKE.
 PUSH BLADE SWITCH DOWN TO MAKE SURE BLADE IS DISENGAGED.
 SET CHOKE AND THROTTLE.
 TURN KEY TO START ENGINE.

TO OPERATE:
 ADJUST CHOKE AND THROTTLE.
 PULL BLADE SWITCH UP TO ENGAGE BLADE.
 PUSH PARKING BRAKE LEVER DOWN TO RELEASE BRAKE.
 MOVE MOTION CONTROL LEVERS IN THE DIRECTION OF TRAVEL REQUIRED.
 INCREASE / DECREASE SPEED WITH AMOUNT OF MOTION CONTROL LEVERS TRAVEL FROM CENTER / NEUTRAL POSITION.

TO STOP:
 MOVE MOTION CONTROL LEVERS TO CENTER / NEUTRAL POSITION.
 PUSH BLADE SWITCH DOWN TO DISENGAGE BLADE.
 PULL UP ON BRAKE LEVER TO SET BRAKE.
 TURN KEY TO OFF POSITION AND REMOVE.
 MAKE SURE ALL MOVEMENT HAS STOPPED BEFORE DISMOUNTING.

73601

Section 2 – SAFETY MESSAGES AND SYMBOLS

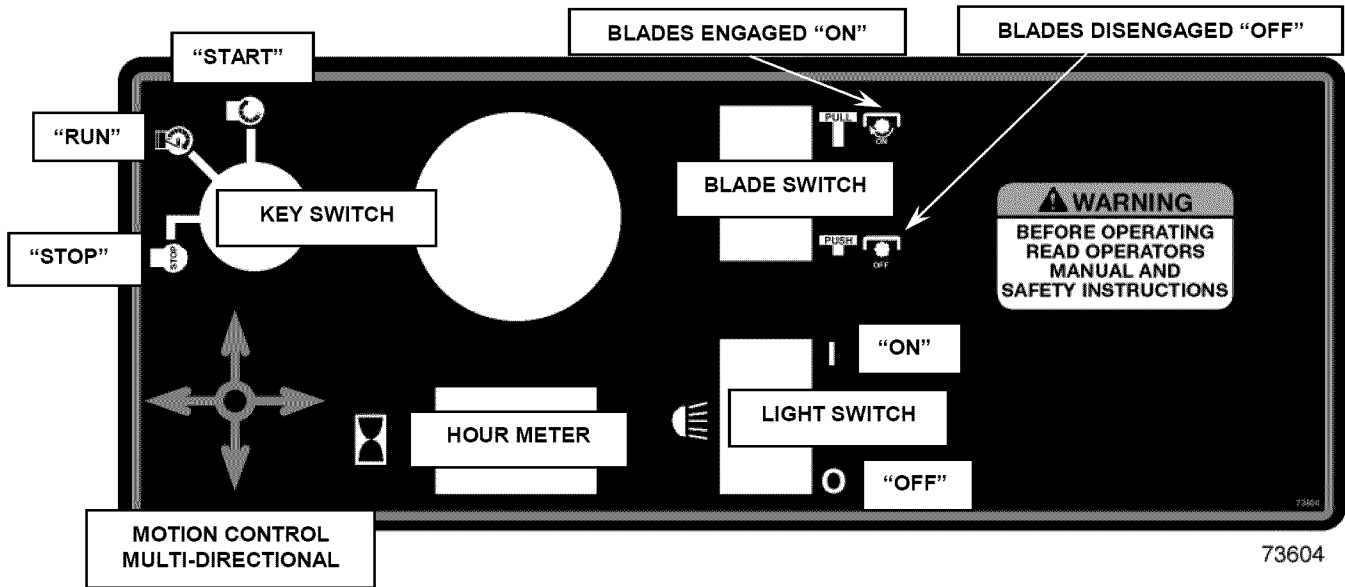

DANGER! ROTATING BLADES
 KEEP CHILDREN AND OTHERS OUT OF MOWING AREA



DANGER! ROTATING BLADES

Section 3 - OPERATING INSTRUCTIONS

2.1 PRE-START CHECK LIST

Make the following checks and perform the service required before each start-up.

2.1.1. Check tires and add or release air as needed to bring pressure to 12 psi in drive tires. Pressure in front deck caster wheels should be 25 psi.

2.1.2. Check guards, deflectors and covers to make sure all are in place and securely tightened.

2.1.3. Check engine oil and add oil as needed to bring level up to the FULL mark. Refer to engine owner's manual for oil specifications. See Figure 2.1.

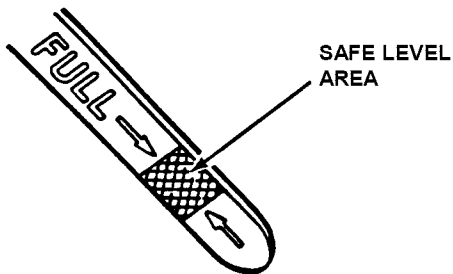

FIGURE 2.1

2.1.4. Check Blade switch to insure it works freely. Switch is pulled "OUT" for blade engagement or pushed back "IN" for blade disengagement. See Figure 2.2. **IMPORTANT:** Disengagement stops blades.

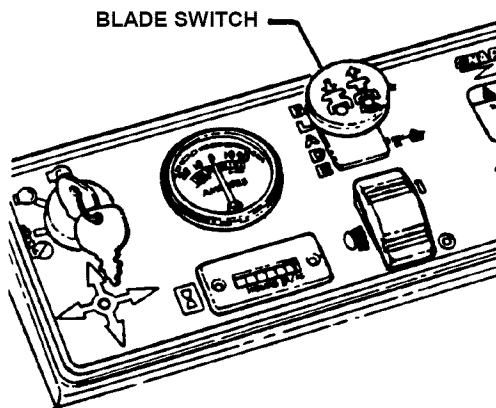

FIGURE 2.2

2.1.5. Clean exterior surfaces of cutting deck and engine of any accumulation of dirt, grass, oil, etc. Keep engine air intake screen and cooling fins clear at all times.

2.1.6. Add fuel to tank of the machine outside where fumes can safely dissipate. Make sure fuel filler cap is tight. Refer to engine owner's manual for fuel specifications.

2.1.7. Adjust position of operator's seat. The seat is mounted on slides. Locate latch lever beneath the seat. Move lever towards the left and slide seat to the desired position. Release latch.

2.1.8. Place mower in desired cutting height setting. Grasp deck lift lever and depress release button located at tip of lever. Move lever to desired setting, 1 thru 7, and release latch. See Figure 1.1.

IMPORTANT: This machine is equipped with hydrostatic drive. The forward and rearward movement of the mower is controlled by a joystick lever. Joystick operations should be performed only from the operator's position in the seat. A small movement of the joystick can cause the machine to move instantly. Move joystick very carefully and slowly.

ROLL RELEASE: To roll the machine without the engine running, pressure within the hydraulic pumps must be released. There is one lever on the upper right side of each pump that is used to release the pressure. Rotate lever counter-clockwise and secure in that position. See Figure 2.3

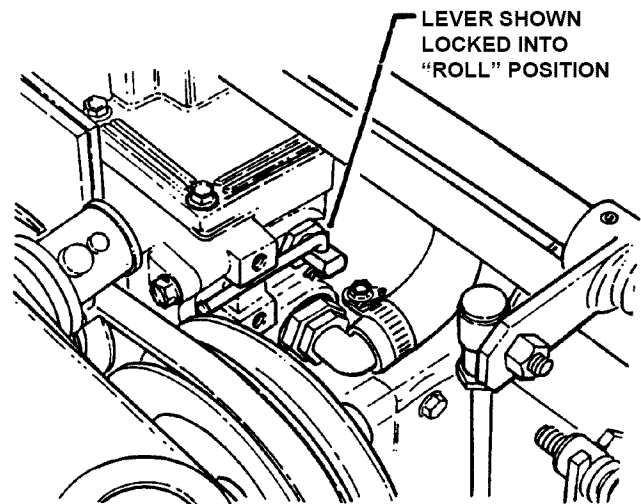
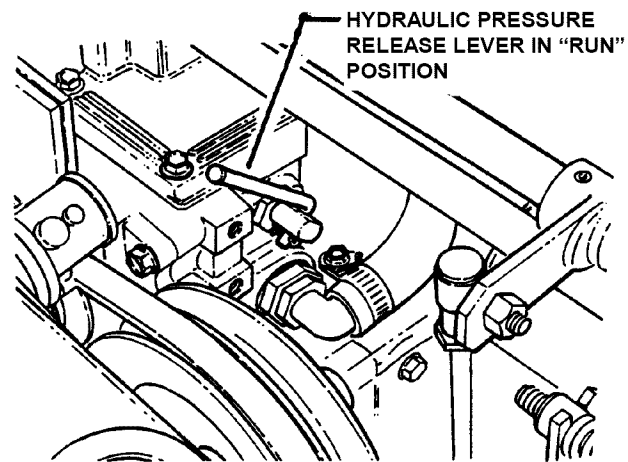

FIGURE 2.3

Section 3 - OPERATING INSTRUCTIONS

2.2 STARTING & STOPPING – ENGINE, BLADES, PARKING BRAKE

This machine is equipped with dual hydrostatic wheel drive transmissions. Each transmission is controlled by a single motion control lever or joystick. This single control lever (joystick) controls the direction of motion, Forward and Reverse, and the speed of motion. Move the joystick forward to propel the machine forward. Move the control rearward to propel the machine in reverse. The speed of motion is continuously variable from neutral (zero) to maximum. Moving the joystick farther from the neutral position will cause the speed of motion to increase. To turn, move the joystick towards the side you want to turn to. DO NOT make sudden changes in speed or direction. Always slow machine motion before turning. To stop the motion of the machine bring the joystick back to the neutral position. Engage parking brake.

2.2.1. STARTING ENGINE

When the ignition key is turned the engine will not start or turn over unless the parking brake is engaged and the blade switch is pushed in to "OFF".

1. Complete pre-start checklist.
2. Sit in operator's seat.
3. Push blade switch in to "OFF", blades disengaged position and engage parking brake. See Figure 2.2 and Figure 2.6.
4. Move choke control forward to choke position to start a cold engine. See Figure 2.4.
5. Move engine speed control to the Rabbit "FAST" position. See Figure 2.4
6. Turn key to the start position until engine starts. See Figure 2.5.

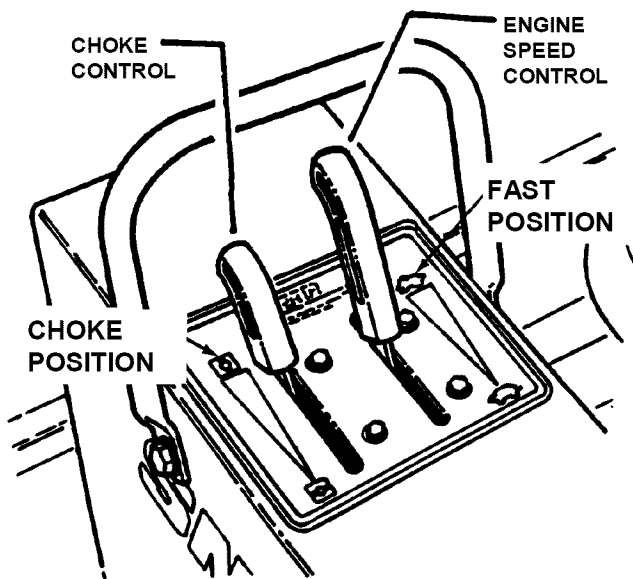

FIGURE 2.4

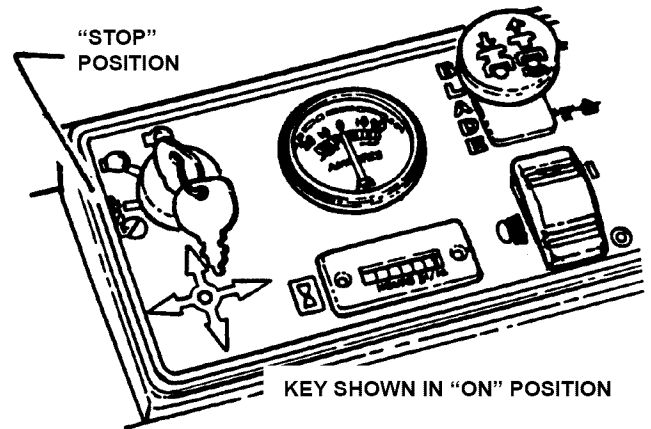

FIGURE 2.5

NOTE: If after 5 seconds of cranking the engine does not start, release the key. Attempt starting again after waiting for approximately 20 seconds.
7. After engine starts, move the choke control to the "OFF" or no choke position. Allow a brief warm-up until engine runs smooth.

2.2.2. STOPPING ENGINE

1. Stop engine by turning key to "STOP" position. Move engine speed control to the Turtle "SLOW" position and turn key to "STOP". See Figure 2.5.

WARNING

DO NOT operate blades in reverse. **STOP BLADES.** **LOOK and SEE** behind and down for children, pets and hazards before and while backing.

2.2.3. STARTING MOWER BLADES

1. Start engine and set engine speed control to the Rabbit "FAST" position.
2. Pull the Blade Switch out to the "ON" position to engage the mower blades. See Figure 2.2.

2.2.4. STOPPING MOWER BLADES

1. Push Blade Switch in to "OFF" position to disengage the blade.

WARNING

Once blades are disengaged, they should come to a complete stop in 7 seconds. If the blades continue to rotate after 7 seconds, the electric clutch should be checked. Replacement of electric clutch may be necessary. Return the machine to an authorized dealer for replacement. **DO NOT CONTINUE** to operate mower if blades fail to stop in 7 seconds.

2. Move engine speed control to the Turtle "SLOW" position. Turn key to "STOP" position. Engage parking brake.

Section 3 - OPERATING INSTRUCTIONS

2.2.5. PARKING BRAKE

1. Engage parking brake by pulling the parking brake lever back to the engaged position.

NOTE: Motion control lever must be in the Neutral position to engage brake. See Figure. 2.6.

NOTE: Engaging the parking brake locks the motion control lever (joystick) in the neutral position.

2. Release parking brake by pushing parking brake lever forward to the released position. See Figure 2.7.

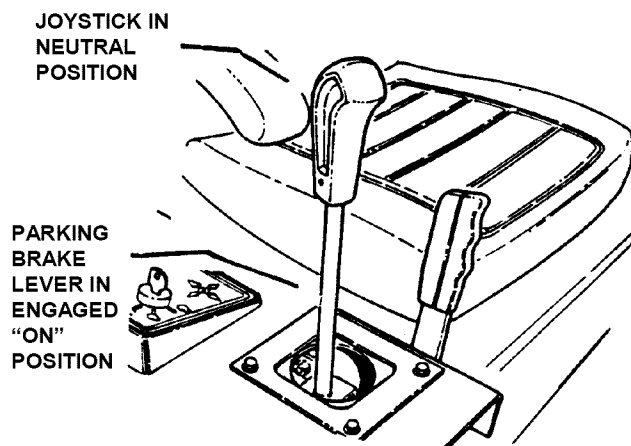

FIGURE 2.6

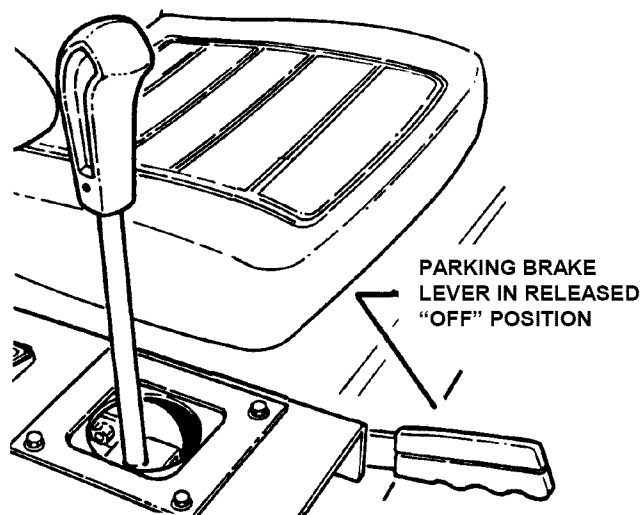

FIGURE 2.7

Section 3 - OPERATING INSTRUCTIONS

2.3 CUTTING HEIGHT ADJUSTMENT

1. Adjust cutting height as desired to any position, using deck lift lever. See Figure 2.8.

NOTE: The engine does not have to be running to adjust cutting height.

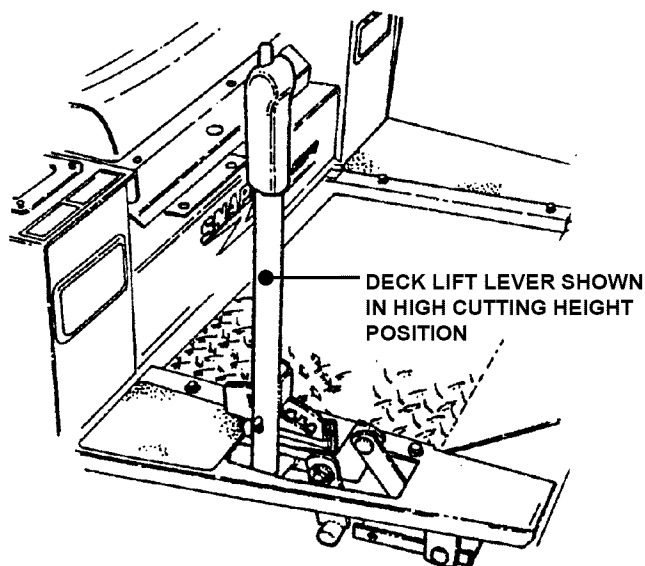

FIGURE 2.8

2.4 OPERATION- MOTION CONTROLS

2.4.1. DRIVING MACHINE

1. Start engine. Release parking brake.
2. Move motion control (joystick) gently and with caution in desired direction:

FORWARD- Move control forward.

REVERSE- Move control to the rear.

LEFT TURN- Move control towards left.

RIGHT TURN- Move control towards right.

ZERO RADIUS TURN- Move control diagonally from neutral in desired direction. See Figure 2.9.

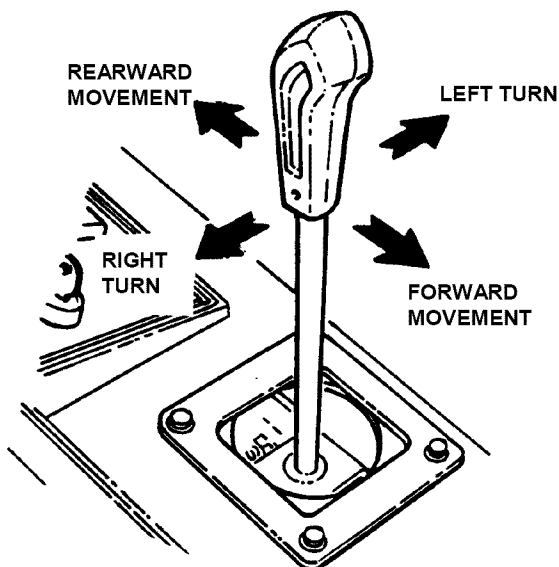

FIGURE 2.9

WARNING

DO NOT make turns at high speed. Slow machine motion. Move motion control lever gently and with caution. DO NOT make sudden changes in speed or direction.

2.4.2. STOPPING MACHINE

1. Return motion control lever (joystick) to neutral.

IMPORTANT: Operator must use hand assistance to bring motion control lever to the neutral position.

2. Engage parking brake.

3. Push blade switch in to "OFF" blades disengaged position.

4. Stop engine. Move engine speed control to turtle "SLOW" position. Turn key to stop position.

5. Remove key.

WARNING

DO NOT park the machine on slopes. DO NOT leave machine with engine running. Stop engine. Stop blades. Engage parking brake. Remove key.

Section 4 - MAINTENANCE

3.1 INTRODUCTION

To retain the quality of the SNAPPER mower, use genuine SNAPPER replacement parts only. Contact a local SNAPPER dealer for parts and service assistance. For the correct part or information for a particular SNAPPER mower, always mention the model and serial number. SNAPPER recommends returning the mower to an authorized SNAPPER dealer annually for inspection and addition of any new devices which might upgrade the safety of the mower. For the nearest SNAPPER dealer in your area, check the yellow pages under the heading LAWN MOWERS. For engine parts and service, look for the engine manufacturer's dealers under the heading, ENGINES - gasoline.

3.2 SERVICE - AFTER FIRST 5 HOURS

WARNING

DO NOT attempt any maintenance, adjustments or service with engine running. STOP engine. STOP blades. Set brake. Remove key. Remove spark plug wires and secure away from spark plugs. Engine and components are HOT. Avoid serious burns, allow sufficient time for all parts to cool.

3.2.1. CHANGE ENGINE OIL

1. Change engine oil as follows:
 - a. Place a 4 quart minimum capacity container under the end of the oil drain.
 - b. Rotate counter clockwise and pull out to open the drain plug. See Figure 3.1.

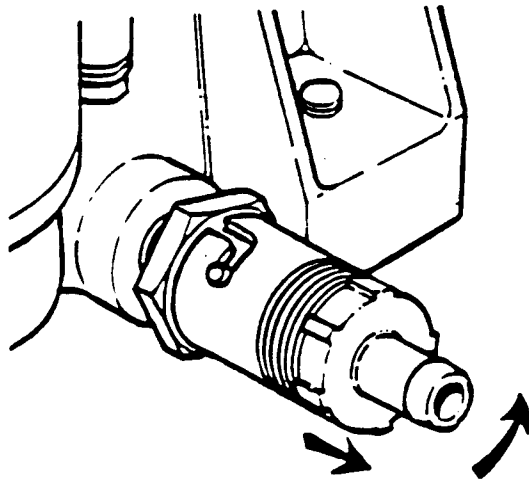

ROTATE PLUG COUNTER CLOCKWISE THEN PULL OUT TO DRAIN OIL

FIGURE 3.1

- c. After all the oil has drained, close the drain by pushing in and rotating clockwise to close. Wipe up any oil that may have spilled. Dispose of drained oil properly. See Figure 3.1.

- d. Fill engine crankcase with new oil. Refer to your engine owner's manual for oil specifications.
- e. Change oil filter at every oil change. Refer to your engine owner's manual for service instructions.

3.2.2. CHECK MOWER BLADE

1. Stop Engine. Remove key. Disconnect spark plug wire(s) and secure away from spark plug(s).
2. Engage parking brake.
3. Use a hydraulic floor jack or hoist to raise machine high enough to gain access to the underside of deck. Secure machine with safety blocks.

WARNING

Wear heavy leather gloves when handling or working around cutting blades. Blades are extremely sharp and can cause severe injury. DO NOT use a cutting blade that shows signs of excessive wear or damage. Refer to section "MOWER BLADE REPLACEMENT" for proper blade inspection and service procedures.

4. Check torque of blade mounting bolts. As necessary, torque to 70 to 80 ft. lbs. See Figure 3.2.
5. Check blade for sharpness, wear and damage. Refer to Section "BLADE WEAR LIMITS".

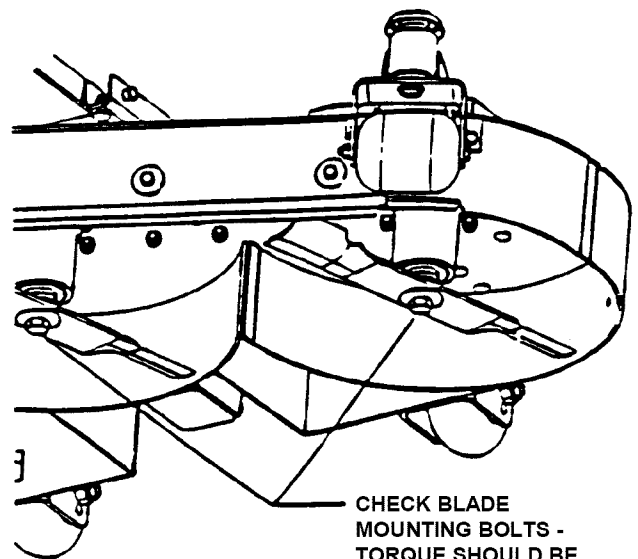

FIGURE 3.2

6. Check blade for straightness.

Section 4 - MAINTENANCE

3.2.3. CHECK MOWER DRIVE BELT

1. Foot Rest Removal

- a. Lower deck to lowest setting.
- b. Remove foot rest. See Figure 3.3.
- c. Removal of foot rest will allow access to deck belt.

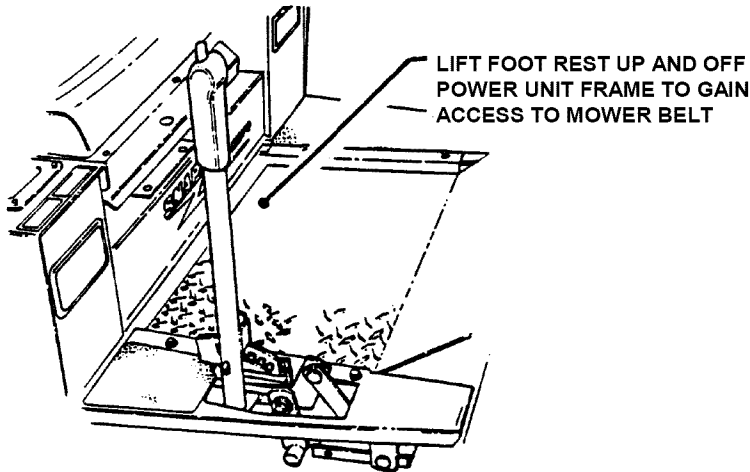

FIGURE 3.3

2. Check Belt Tension

The idler and spring provide proper belt tension and require no adjustment. If belt is frayed, slit, severed or belt strands exposed, replace belt before operating mower.

3.3 AFTER EVERY 25 OPERATING HOURS

3.3.1. ENGINE

1. Engine Oil

Change engine oil. Refer to Section "CHANGE ENGINE OIL". Refer to engine owner's manual for oil specifications.

2. Air Filter

Refer to engine owner's manual for service instructions.

3.3.2. MOWER COMPONENTS

1. Mower Drive Belt

No adjustment required. Replace belt as needed.

2. Mower Blade

Check blade for sharpness, wear, damage, and torque. Refer to Section "MOWER BLADE REPLACEMENT".

3. Mower Deck Levelness

Check mower deck for proper levelness. Adjust as required. Refer to Section "MOWER DECK ADJUSTMENT - LEVELNESS".

4. Clean Mower Deck

- a. Remove key from ignition switch.
- b. Remove spark plug wire(s) and secure away from spark plug(s).

- c. Raise mower deck to its highest setting. It may be necessary to raise mower deck higher using a hydraulic floor jack. Secure machine with safety blocks.
- d. Clean underside of mower deck, removing all accumulation of grass clippings and debris.
- e. Clean top of deck, removing all grass clippings and debris.

5. Mower Blade Spindle - Lubrication

- a. Remove foot rest to gain access to lubrication fitting located on the top of deck below deck pulleys.
- b. Lubricate with Kendall NLGI No. 2 lithium grease or equivalent, from a grease gun until grease purges from vent located on spindle housing underneath deck. See Figure 3.4.

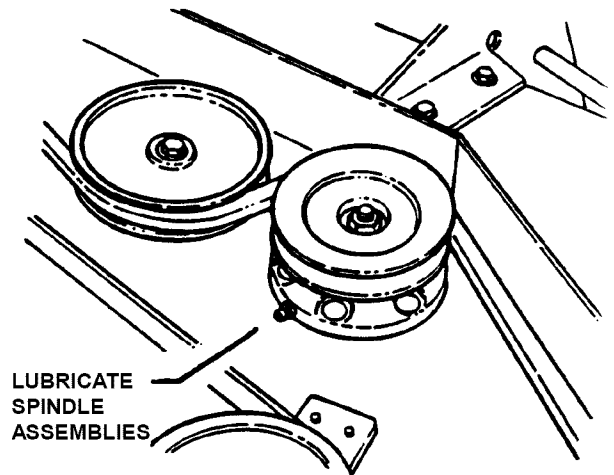

FIGURE 3.4

6. Mower Deck Linkage - Lubrication

Lubricate all mower deck linkage pivot points with a light coat of motor oil.

WARNING

DO NOT attempt any maintenance, adjustments or service with engine running. STOP engine. STOP blades. Set brake. Remove key. Remove spark plug wires and secure away from spark plugs. Engine and components are HOT. Avoid serious burns, allow sufficient time for all parts to cool.

Section 4 - MAINTENANCE

3.3.3. RIDING MOWER - LUBRICATION

1. Front Wheel Bearings

Lubricate with Kendall NLGI No. 2 lithium grease or equivalent, from a grease gun. See Figure 3.5.

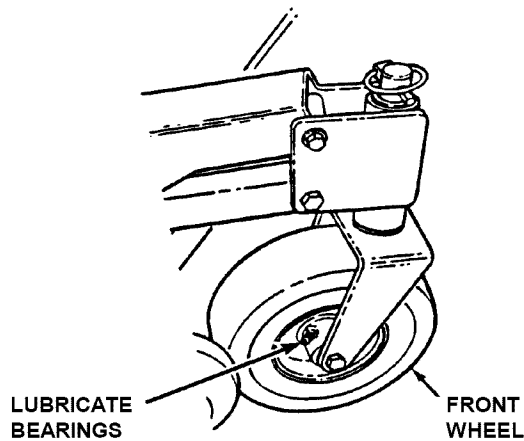
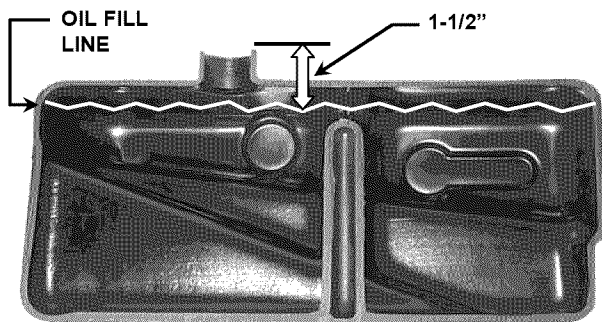

FIGURE 3.5

2. Transaxle

Check the level of fluid in both of the fluid reservoirs. Wipe away all dirt and debris from around reservoir cap before removing. Oil must remain absolutely clean! Check with machine on a level surface with engine "OFF". Engage park brake. Fill reservoir as needed to bring level up to 1-1/2 inches below the top of the filler neck. Use clean, fresh premium hydraulic oil having a viscosity equivalent to SAE 20W20, SAE30 or SAE40. The fluid should be chemically stable, incorporating rust and oxidation inhibitors. Make sure funnels, pouring spouts and oil can are completely clean. Reinstall reservoir cap. See Figure 3.6. **IMPORTANT:** DO NOT remove or service the transaxle fluid filters. This service should be made periodically by an authorized SNAPPER dealer. See the service schedule to determine the recommended change interval.



HYDRAULIC OIL RESERVOIR

IMPORTANT: FLUID LEVEL MUST BE ABOVE TOP OF BAFFLE. RESERVOIR CAPACITY IS ONE (1) GALLON. DO NOT OVERFILL.

FIGURE 3.6

3. Power Transfer Shaft

Lubricate power transfer shaft with Kendall NLGI No. 2 lithium grease or equivalent, from a grease gun. See Figure 3.7.

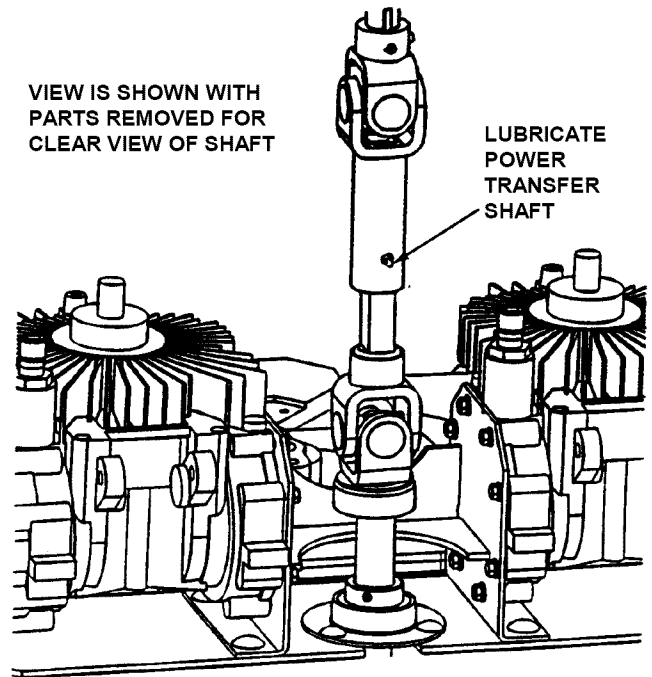

FIGURE 3.7

4. OTHER LUBRICATION POINTS

Lubricate machine caster wheel shafts, traction drive shaft and mower deck idler arm with Kendall NLGI No. 2 lithium grease or equivalent, from a grease gun.

3.4 BEFORE OPERATING MACHINE

1. Clean all dirt and debris from around the two hydraulic fluid reservoirs. Especially around the top and cap area.
2. Clean all dirt and debris from the cooling fins on the engine and from both hydraulic pumps.

3.5 ANNUALLY (END OF EACH SEASON)

Perform all maintenance as described in Section "AFTER EVERY 25 OPERATING HOURS".

3.5.1. ENGINE

Service engine according to engine owner's manual.

(Continued on next Page)

Section 4 - MAINTENANCE

3.5 ANNUALLY (END OF EACH SEASON)

(Continued from previous Page)

3.5.2. FUEL FILTER

Service fuel filter as instructed below. Turn key to "OFF" position. Engine MUST be stopped and MUST be cold before removing filter. Clamp fuel line to prevent fuel spillage or perform filter change when fuel tank and fuel line are empty.

WARNING

Allow engine to cool for at least ten minutes before performing service or maintenance. DO NOT smoke near fuel components when performing service or maintenance. DO NOT perform service and maintenance near an open flame. Wipe off any spilled fuel before starting engine. DO NOT run engine indoors.

1. Remove fuel line clamps from fuel filter.
2. Remove fuel lines from filter. Discard filter.
3. Install new fuel filter. Reinstall fuel line clamps. See Figure 3.8.

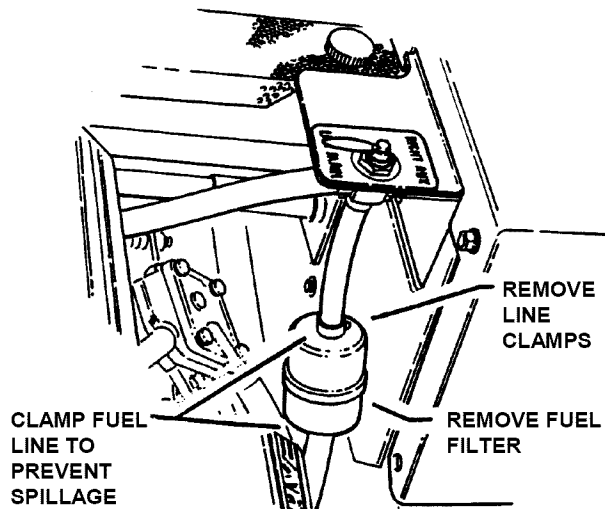

FIGURE 3.8

3.6 DECK REMOVAL

Move power unit/mower deck to an area where the mower deck is to be disconnected. Turn engine "OFF" and remove key from switch. Remove spark plug wire(s) and secure away from spark plug(s). Engage parking brake.

1. Move deck lift lever and set the mower deck to the highest cutting position. See Figure 3.9.
2. Place a wooden block under the front and rear edge of the mower deck.
3. Move deck lift lever and set the mower deck to a lower cutting position until deck rests on wooden blocks. See Figure 3.9.

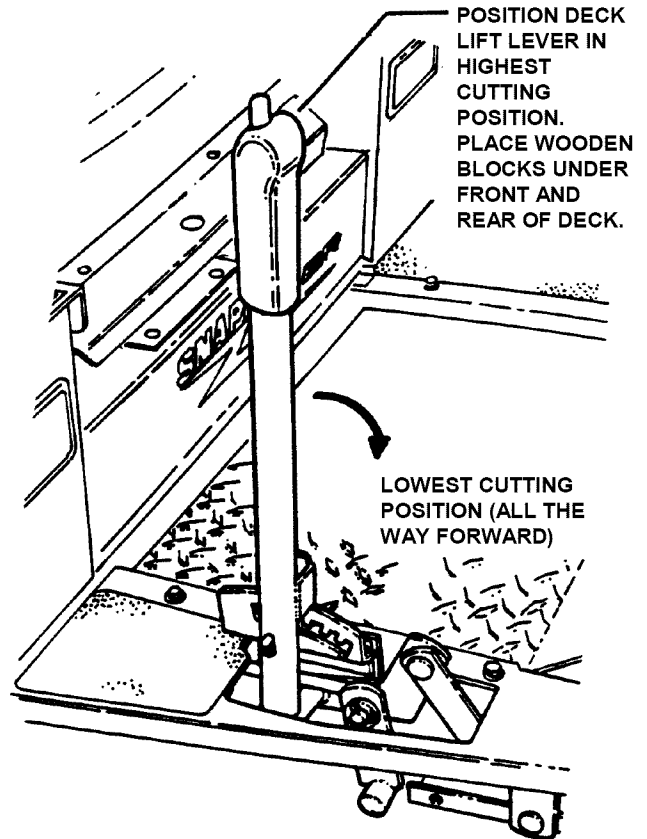

FIGURE 3.9

Section 4 - MAINTENANCE

3.6 DECK REMOVAL (Continued from previous page)

4. Remove shoulder bolts, washers and nuts from rear lift arm. See Figure 3.10.

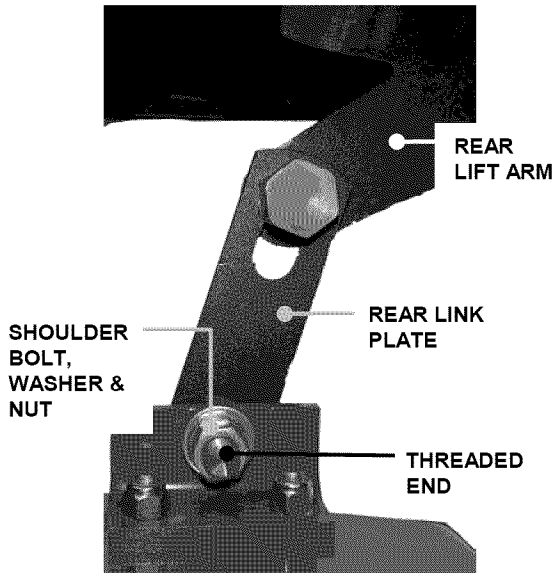

FIGURE 3.10

5. Disconnect pull bar from front axle by removing clevis pins and cotter pins. See Figure 3.11.

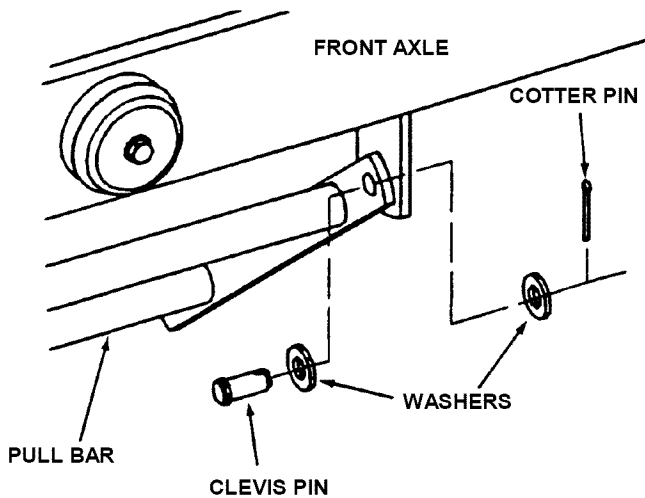

FIGURE 3.11

6. Pull lock collar back and slide power transfer shaft away from power take off shaft (located on power unit below hydro pumps). See Figure 3.12.

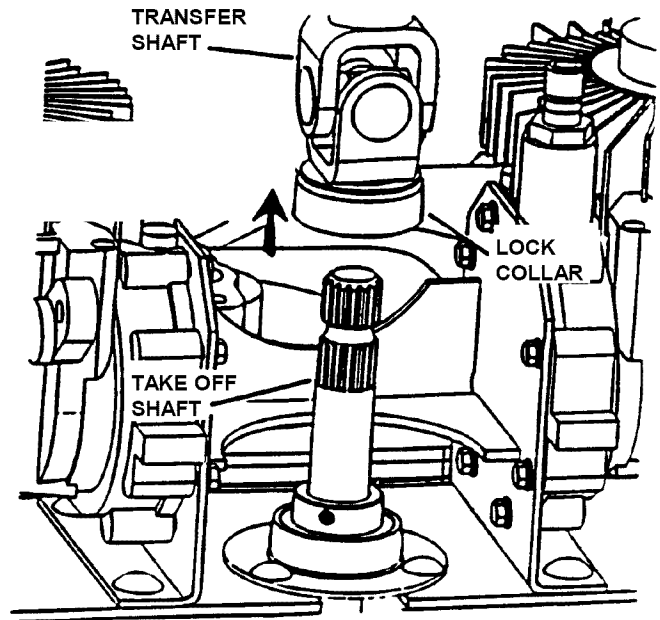

FIGURE 3.12

IMPORTANT: Mower deck is extremely heavy. Be very careful when removing deck from power unit.

7. Remove wooden blocks from underneath deck and roll/slide deck from underneath power unit.

WARNING

DO NOT attempt any maintenance, adjustments or service with engine running. **STOP** engine. **STOP** blades. Set brake. Remove key. Remove spark plug wires and secure away from spark plugs. Engine and components are **HOT**. Avoid serious burns, allow sufficient time for all parts to cool.

3.7 POWER TRANSFER SHAFT REMOVAL

Engage parking brake. Turn engine "OFF" and remove key. The power transfer shaft connects the power unit to the mower deck. The shaft is telescoping for easy removal. Slide locking collar back toward mower deck and shaft will slide off. See Figure 3.12.

Section 5 - ADJUSTMENTS & REPAIR

⚠ DANGER ⚠
Exercise **EXTREME CAUTION** when making this adjustment, due to close proximity of moving parts.

4.1 NEUTRAL POSITION ADJUSTMENTS

The joystick controls the movement and stopping of the machine. Move the joystick to the center or neutral position to stop machine. **IMPORTANT: Always return the joystick with hand assistance to the neutral position. If machine does not come to a complete stop or has any movement when joystick is moved to the neutral position, adjustment must be made.**

1. Turn key to "OFF" position.
2. Raise both wheels off the ground. Wheels should be high enough to rotate freely. Secure with safety blocks.
3. Disconnect parking brake rod from parking brake.
4. Engage parking brake lever. **NOTE:** Engaging parking brake without brake rod connected will lock joystick in center or neutral position.
5. Turn key to start position and start unit.
6. Both wheels should not have any movement, not rotating.
7. If wheel(s) are rotating, disconnect transmission control rods from cross shaft and turn adjusting bolts located on pump(s) clockwise, or counter-clockwise, until wheel(s) stop rotating. See Figure 4.1.
8. With wheels in neutral, (not rotating) stop engine and readjust control rods until they fit into the cross shaft arms with no wheel creep.
9. Reconnect park brake rod.

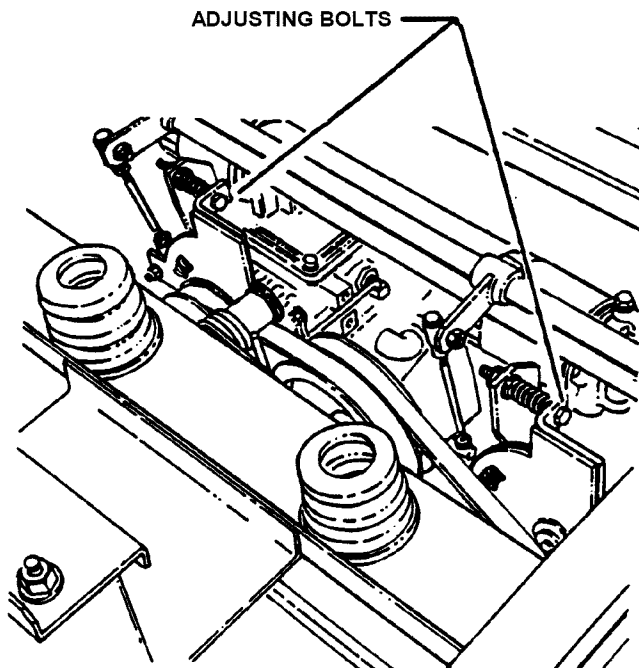

FIGURE 4.1

4.2 MOWER DECK & COMPONENT ADJUSTMENTS

The following mower deck and component adjustments and repairs can be made by the owner. However, if there is difficulty in making these adjustments and repairs, it is recommended that these repairs be made by an authorized SNAPPER dealer.

4.2.1. MOWER DECK ADJUSTMENT (LEVELNESS) SIDE to SIDE and FRONT to REAR

Before making deck leveling adjustments, check tires and add or release air as needed to bring pressure to 12 psi in drive tires. Pressure in front caster wheels should be 25 psi. If tires are properly inflated and mowing is still uneven, adjust deck levelness as follows:

SIDE to SIDE LEVEL

1. Place machine on a smooth level surface.
2. Check blade tips by rotating blades until tips are pointing to the sides of the deck. Check the measurement of outside blade tips to the ground on both blades. The measurement of each of the outside blade tips should be within 1/8" of each other. If measurement of the blade tips is not within 1/8", adjustment should be made to the higher side of the deck to lower it to within the correct measurement.
3. Move deck lift lever and set the mower deck to the highest cutting position.
4. Place a wooden block under the front and rear edge of the mower deck.
5. Move deck lift lever and set the mower deck to a lower cutting position until deck rests on wooden blocks.

(Continued on Next Page)

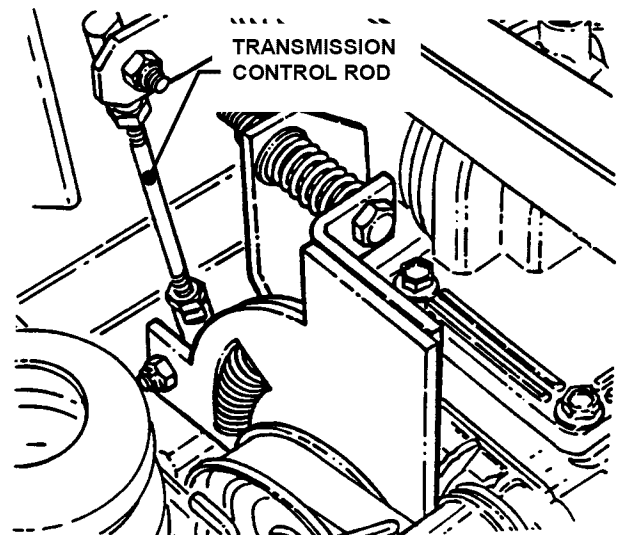

FIGURE 4.1A

Section 5 - ADJUSTMENTS & REPAIR

4.2.1. MOWER DECK ADJUSTMENT (LEVELNESS) (Continued)

6. Loosen the nuts and bolts that secure both front and rear deck support brackets on the high side of deck. Located above each support bracket, on the top part of the power unit frame, are three shim plates. Remove the shim plates on both of the front and rear lift arms and position plates between the support bracket and the frame of the power unit. Inserting the shim plates in this procedure will lower that side of the deck. Retighten the support bracket nuts and bolts to 20 to 30 ft. lbs. of torque. See Figure 4.2.

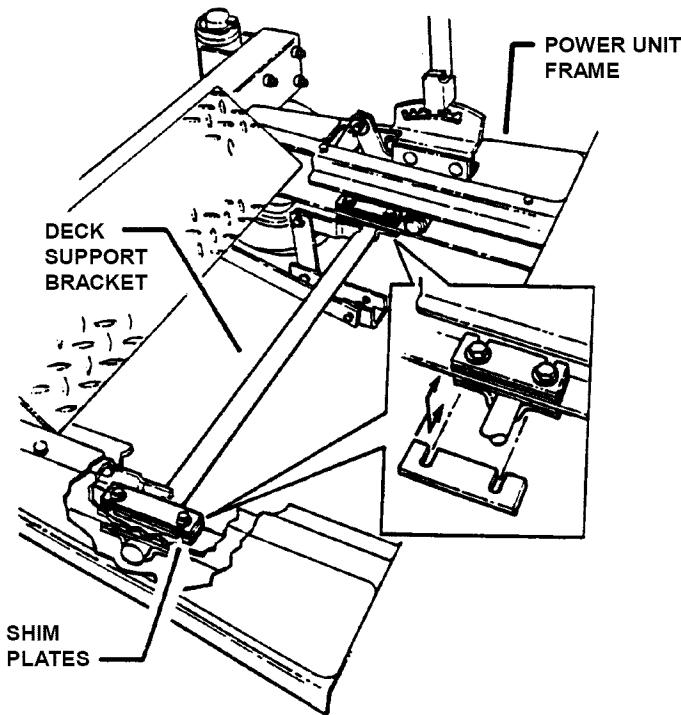

FIGURE 4.2

7. Move deck lift lever and set the mower deck to the highest cutting position and recheck side to side blade tip dimensions. If both blade tips are within 1/8" of each other then levelness is correct. If blade tips are still unlevel repeat steps 1 through 6 and add another shim plate until deck is level.

FRONT to REAR LEVEL

8. Place machine on a smooth level surface.
9. Check blade tips by rotating the outside blades until tips are pointing to the front and rear of deck. Check the measurement of blade tips to the ground on both blades. Front to rear measurement should be 1/4" to 3/8" higher in the rear. If measurement of the blade tips are not within the previously mentioned measurement, adjustment should be made.

10. Move deck lift lever and set the mower deck to the highest cutting position.

11. Place a wooden block under the front and rear edge of the mower deck.

12. Move deck lift lever and set the mower deck to a lower cutting position until deck rests on wooden blocks. This will relieve pressure from deck lift components.

13. **NOTE:** The timing rod connects the front and rear lift arms and maintains the deck in the same attitude through all heights of cut. Adjust the deck by loosening and rotating the timing rod adjusting nuts. Rotate both nuts forward to lower the rear of the deck or rearward to raise the rear of the deck. Tighten the nuts securely. See Figure 4.2A.

14. Raise cutting deck to highest cutting position and check measurement. If blade tips are not within correct measurement repeat steps 8 through 13 until deck is level.

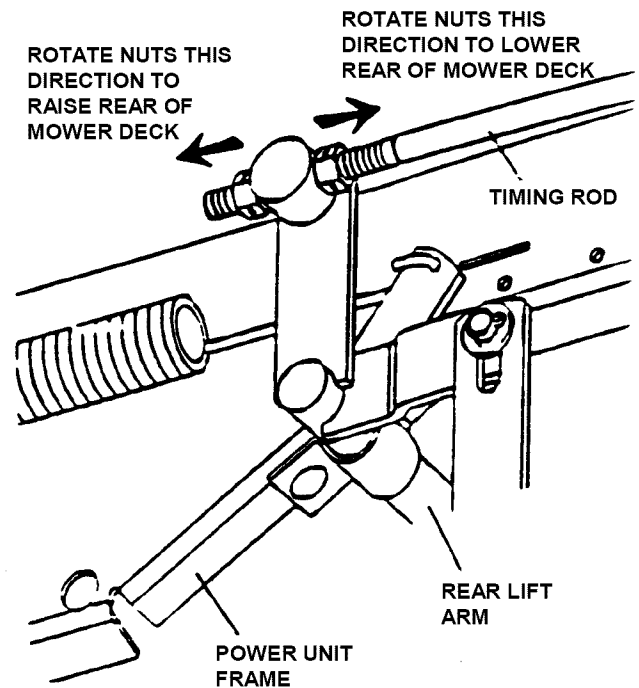

FIGURE 4.2A

Section 5 - ADJUSTMENTS & REPAIR

WARNING
Before attempting any adjustments, maintenance, service, or repairs, stop engine and blade, always remove key from ignition switch, remove spark plug wire(s) and secure wire(s) away from spark plug(s).

4.3 PARKING BRAKE ADJUSTMENT

1. The parking brake can be adjusted by removing the rod from the lever and rotating it clock-wise to increase brake tension. When properly adjusted, the parking brake lever should require 18 to 22 pounds of force to set the brake. If this adjustment does not result in proper braking action contact your authorized SNAPPER dealer for corrective action. See Figure 4.3.

WARNING
Do not operate this machine if the brakes are not functioning properly!

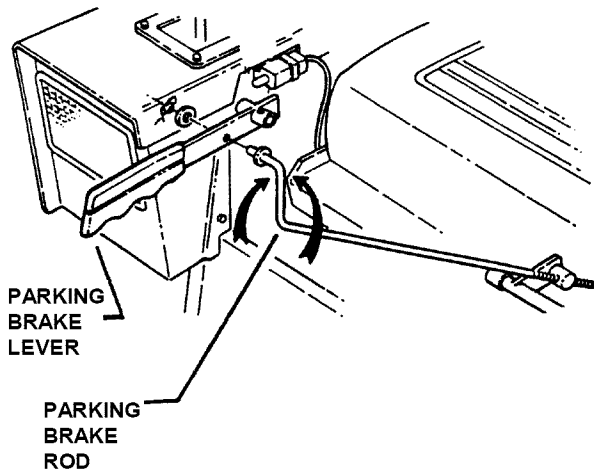

FIGURE 4.3

4.4 ENGINE ADJUSTMENTS & REPAIR

Refer to the engine owner's manual for engine adjustments and/or repairs.

WARNING
Wear heavy leather gloves when handling or working around cutting blades. Blades are extremely sharp and can cause severe injury. DO NOT use a cutting blade that shows signs of excessive wear or damage.

4.5 MOWER BLADE REPLACEMENT

4.5.1. BLADE WEAR LIMITS

1. Inspect blade frequently for signs of excessive wear or damage. See Figure 4.4.

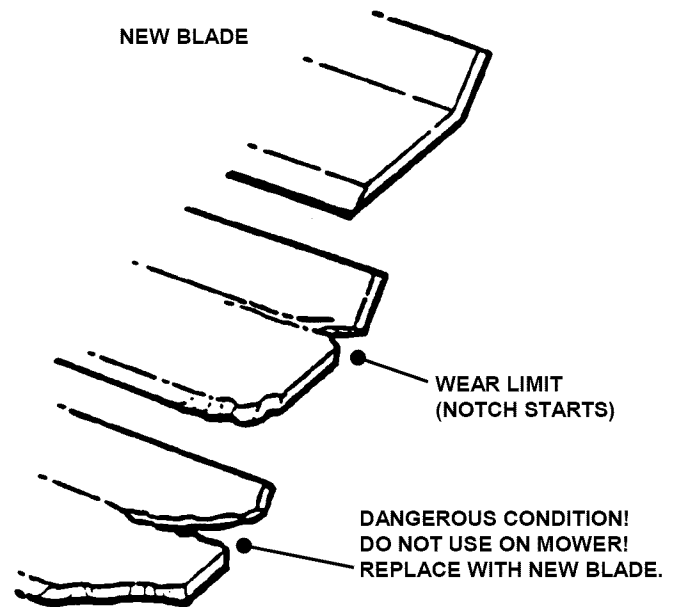

FIGURE 4.4

Section 5 - ADJUSTMENTS & REPAIR

4.5.2. BLADE SHARPENING

1. Remove blade. See Figure 4.5.

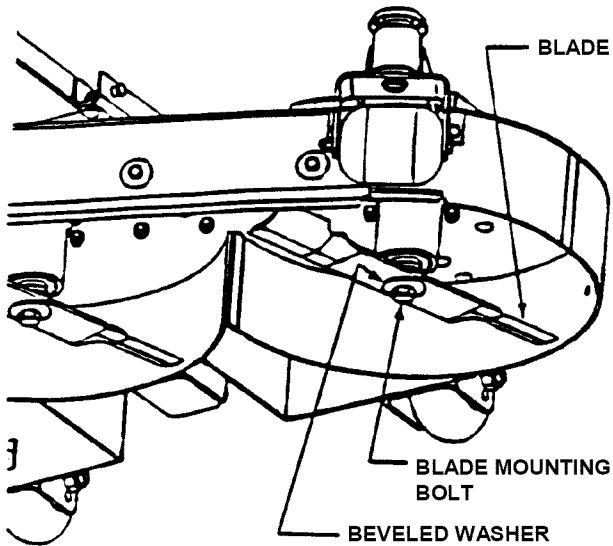

FIGURE 4.5

2. Inspect condition of blade. See Figure 4.4.
3. If blade is in good condition, sharpen at 22 to 28 degrees. DO NOT sharpen beyond original cutting edge. See Figure 4.6.

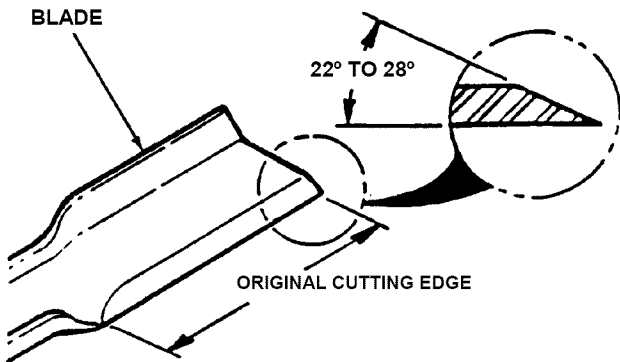

FIGURE 4.6

4. Check blade balance after sharpening. If necessary, correct blade balance by grinding the heavy end of blade.

IMPORTANT: Blade balancing should be performed by a qualified dealer.

5. Reinstall blade. See Figure 4.5. Torque blade mounting bolts to recommended range of 70 to 80 ft. lbs.

4.6 MOWER DRIVE BELT REPLACEMENT

Inspect mower drive belt. Replace belt if it shows signs of excessive wear, damage and/or is broken.

4.6.1. BELT REMOVAL

1. Remove power unit foot rest.
2. Remove old belt.

4.6.2. BELT REPLACEMENT

1. Route belt around blade pulleys and idler pulley in same the position as old belt was removed. It may be necessary to use a pry bar to pull idler pulley back to install belt. See Figure 4.7.
2. Reinstall power unit foot rest.

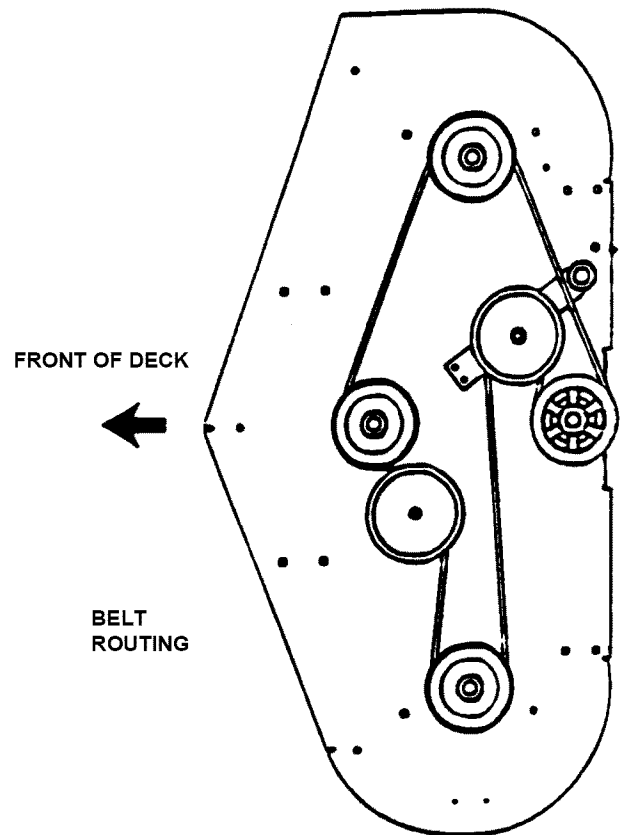

FIGURE 4.7

Section 5 - ADJUSTMENTS & REPAIR

WARNING

Shield the positive terminal with terminal cover located on battery harness. This prevents metal from touching the positive terminal which could cause sparks. Cables must be connected to battery terminals in the proper position. RED (Positive) cable must go to the (+) terminal. BLACK (Negative) cable must go to the (-) terminal.

4.7 BATTERY

4.7.1. BATTERY REMOVAL

1. Remove battery retainer.
2. Slide terminal cover away from positive terminal.
3. Observe and note cable positions on battery. See Figure 4.8.
4. Disconnect cables from battery terminals, disconnecting BLACK (Negative) cable first, then disconnect RED (Positive) last. Retain mounting bolts and nuts.

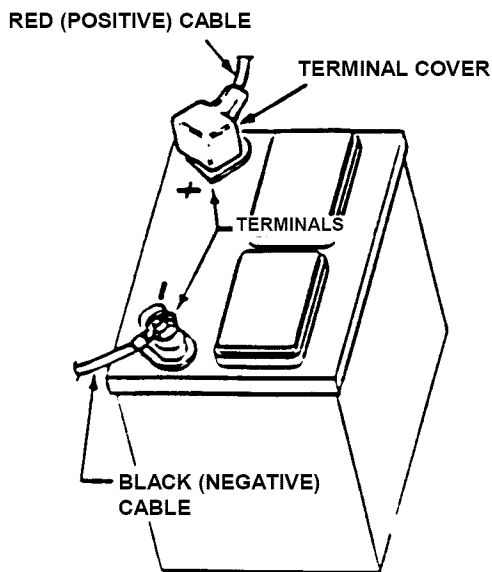

FIGURE 4.8

4.7.2. BATTERY INSTALLATION

1. Position battery into battery compartment.
2. Connect cables to battery terminals. Connect RED (Positive) cable first. Connect BLACK (Negative) cable last.
3. Reinstall battery retainer and positive terminal cover. See Figure 4.9

4.7.3. BATTERY SERVICE

1. Remove battery.
2. Place battery in a well ventilated area on a level surface.
3. Using distilled water, refill cells as required to cover cell plates.

4. With cell caps removed, connect battery charger to battery terminals. RED to positive (+) terminal and BLACK to negative (-) terminal.

5. Slow charge battery at 1 amp for 10 hours. An alternative fast charge should be no more than 2.5 amps for four hours.

6. If battery will not accept charge or is partially charged after 10 hours of charging at 1 amp, replace with new battery.

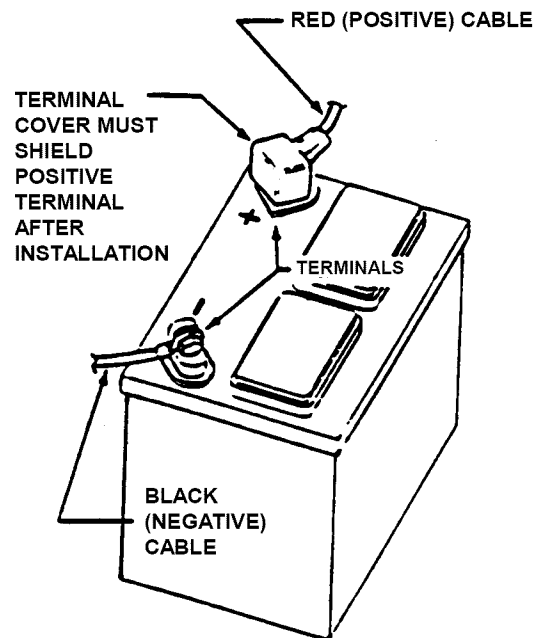

FIGURE 4.9

WARNING

The electrolyte (acid) produces a highly explosive gas. Keep all sparks, flame and fire away from area when charging battery or when handling electrolyte or battery. Electrolyte (acid) is a highly corrosive liquid. Wear eye protection. Wash affected areas immediately after having eye or skin contact with electrolyte (acid). Battery acid is corrosive. Rinse empty acid containers with water and mutilate before discarding. If acid is spilled on battery, bench, or clothing, etc., Flush with clear water and neutralize with baking soda.

Section 5 - ADJUSTMENTS & REPAIR

Battery Condition Chart			
State of Charge	Syringe Hydrometer	Digital Voltmeter	Five Ball Hydrometer
100% Charged w/ Sulfate Stop	1.280	12.80v	Five Balls Floating
100% Charged	1.265	12.60v	Four Balls Floating
75% Charged	1.210	12.40v	Three Balls Floating
50% Charged	1.160	12.10v	Two Balls Floating
25% Charged	1.120	11.90v	One Ball Floating
0% Charged	Less than 1.100	Less than 11.80v	Zero Balls Floating

4.7.4. BATTERY TESTING

There are two types of battery tests: Unloaded and Loaded. The unloaded test is the procedure that will be discussed. It's the simplest and most commonly used. An unloaded test is made on a battery without discharging current. To perform unloaded testing, check charge condition using either a hydrometer or voltmeter.

1. Using a voltmeter, voltage readings appear instantly to show the state of charge. Remember to hook the positive lead to the battery's positive terminal, and the negative lead to the negative terminal.

2. A hydrometer measures the specific gravity of each cell. The specific gravity tells the degree of charge; generally, a specific gravity of about 1.265 to 1.280 indicates full charge. A reading of 1.230 to 1.260 indicates the battery should be charged before testing. The Battery Condition Chart shows the charge level as measured by syringe float hydrometer, digital voltmeter and five ball hydrometer.

4.7.5. NEW BATTERY PREPARATION

1. Remove battery from carton.
2. Place battery in a well ventilated area on a level non-concrete surface.
3. Remove battery cell caps. Fill cells as required with electrolyte (purchased separately) to proper level. Fill to 3/16" above cell plates. Filling battery with electrolyte will bring the battery to 80% charged state.
4. With cell caps removed, connect battery charger to battery terminals; RED to positive (+) and BLACK to negative (-) terminal.

IMPORTANT: 3/16" above cell plates is the recommended level. DO NOT place anything in battery other than specified electrolyte.

WARNING

DO NOT attempt to service or charge the battery while it is installed in the machine. DO NOT use "BOOST" chargers on the battery.

5. Slow charge the battery at 1 amp for 2 hours to bring the battery to full charge.

6. After charging, check level of electrolyte and add as needed to bring level to 3/16" above cell plates.

7. Reinstall cell caps.

8. Install battery into power unit.

9. Connect positive (+) cable (red) first, from wiring harness to the positive terminal (+) on battery using bolt and nut provided in hardware bag. Connect negative (-) cable (black) last, to negative terminal (-) on battery using bolt and nut. Apply a small amount of grease over terminals to prevent corrosion.

10. Install battery retainer and positive terminal cover.

WARNING

Shield the positive terminal with terminal cover located on battery harness. This prevents metal from touching the positive terminal which could cause sparks. Cables must be connected to battery terminals in the proper position. RED (Positive) cable must go to the (+) terminal. BLACK (Negative) cable must go to the (-) terminal.

WARNING

DO NOT OVERFILL!

TROUBLESHOOTING

PROBLEM	PROBABLE CAUSE	CORRECTIVE ACTION
Starter Will Not Crank Engine	1. Battery dead.	1. Service battery.
	2. Blown fuse.	2. Replace fuse.
	3. Electrical connections loose or corroded.	3. Clean and check connections for good contact.
	4. Defective ignition switch.	4. Contact authorized SNAPPER dealer.
Engine Will Not Start	1. Blade engagement switch in the "ON" position.	1. Move blade engagement switch to "OFF".
	2. Park brake not set.	2. Set park brake.
	3. Fuel tank empty.	3. Fill fuel tank with fresh fuel.
	4. Engine needs choking.	4. Move choke control to "CHOKE" position.
	5. Spark plug wire disconnected.	5. Place spark plug wire onto spark plug.
	6. Battery weak or dead.	6. Service battery.
	7. Faulty parking brake, blade or ignition switch.	7. Contact authorized SNAPPER dealer.
Engine Stalls After Running	1. Operator not in seat.	1. Sit in operator's seat.
	2. Choke control in the "CHOKE" position.	2. Move choke control to "OFF" position.
	3. Fuel tank empty.	3. Fill with fuel to proper level.
	4. Engine air pre-cleaner and or air cleaner dirty.	4. Clean free of all debris.
	5. Spark plug defective or gap set improperly.	5. Service spark plug.
	6. Fuel filter stopped up.	6. Replace fuel filter.
	7. Water, debris or stale fuel in fuel system.	7. Drain and clean fuel system.
Engine Loses Power	1. Excessive load on engine.	1. Lessen load.
	2. Engine air pre-cleaner or air cleaner dirty	2. Clean or replace filters.
	3. Engine oil level low.	3. Fill with engine oil to proper level.
	4. Engine cooling fins & air intake screen excessively dirty.	4. Clean cooling fins, air intake screen of all debris.
	5. Spark plug faulty.	5. Service spark plug.
	6. Water, debris or stale fuel in fuel system.	6. Drain and clean fuel system.
Engine Backfires When Turned To "STOP"	1. Throttle control set too "FAST".	1. Set throttle control to "SLOW" and allow engine to idle. Then, turn key to "OFF".
Excessive Vibration	1. Damaged or bent mower blades.	1. Service mower blade(s).
	2. Loose blade components.	2. Service and tighten loose parts.
	3. Loose or missing air lift (if equipped).	3. Replace air lifts. Tighten to proper torque.

(Trouble Shooting Continued on Next Page)

TROUBLESHOOTING

PROBLEM	PROBABLE CAUSE	CORRECTIVE ACTION
Tractor Will Not Move Loss Of Traction	1. Joystick in the neutral "N" position.	1. Place joystick in desired speed position.
	2. Roll release lever is in "ROLL" position.	2. Move roll release lever to the engaged position.
	3. Low transmission hydraulic oil level.	3. Bring hydraulic oil to proper level.
	4. Parking Brake engaged.	4. Move parking brake to disengaged position..
	5. Traction drive belt requires replacement	5. Replace traction drive belt.
Blade(s) Not Cutting	1. Blade engagement switch in the "OFF" position.	1. Move blade switch to the "ON" position.
	2. Clutch belt slipping.	2. Replace clutch belt.
	3. Mower belt slipping.	3. Replace mower belt.
	4. Electric clutch not functioning.	4. Contact authorized SNAPPER dealer.
	5. Check gearbox for damage.	5. Contact authorized SNAPPER dealer.
	6. Power transfer shaft disconnected or damaged.	6. Connect power transfer shaft or repair damage.
Cutting Grass Improperly	1. Uneven tire pressure.	1. Bring to proper pressure.
	2. Cutting height too low or high.	2. Adjust cutting height.
	3. Engine speed too slow.	3. Move throttle control to "FAST" position.
	4. Forward speed too fast.	4. Move joystick to a slower speed.
	5. Terraced cut, side to side.	5. Adjust side to side level
	6. Excessive deck pitch, front to rear.	6. Adjust front to rear level.
	7. Cutting blade(s) dull or damaged.	7. Sharpen cutting edges or replace blade(s).
	8. Blade belt slipping.	8. Replace blade belt.
	9. Check electric clutch.	9. Adjust to proper specifications.
	10. Check clutch belt.	10. Replace clutch belt.
	11. Check gearbox for damage.	11. Contact authorized SNAPPER dealer.
Poor Grass Discharge	1. Engine speed too slow.	1. Move throttle control to "FAST" position.
	2. Forward speed too fast.	2. Move joystick to a slower speed.
	3. Grass is wet.	3. Mow when grass is dry.
	4. Excessively worn or damaged blade(s).	4. Service mower blade(s)
	5. Build up of grass clippings and debris under deck.	5. Clean deck.
	6. Improper blade(s) installed on deck.	6. Install proper SNAPPER blades.
	7. Blade(s) installed improperly on deck.	7. Install blades properly.
Battery Will Not Charge	1. Poor cable connections.	1. Clean cables and battery terminals.
	2. Bad battery cell(s)	2. Replace with new battery.
	3. Faulty alternator.	3. Contact engine manufacturer's dealer.

SERVICE SCHEDULE

ITEM	SERVICE PERFORMED	REF.	EACH USE	5 HRS	25 HRS	50 HRS	100 HRS	EACH SEASON	
Engine Oil	Check Oil Level	Page 9	X						
	Initial Oil Change	Page 13		X					
	Periodic Oil Change	Page 13				X*			
Air Pre-Cleaner	Clean Sponge Element	Engine Manual & Page 14.			X**				
Air Cleaner	Clean or Replace	Engine Manual.			X**				
Spark Plug	Replace	Engine Manual.					X		
Fuel Filter	Replace	Page 16					X		
Engine Cooling System	Clean Shroud & Fins	Engine Manual & Page 15					X**		
Battery	Check Electrolyte	Page 23			X			X	
	Charge Battery	Page 22						X	
	Testing Battery	Page 23						X	
Tires	Check Pressures	Page 9	X			X		X	
Drive Belts	Check For Wear And Tension	Page 14			X	X		X	
Mower Blades	Check For Wear, Damage & Replacement	Pages 20-21	X						
Mower Deck	Clean Debris Accumulation	Page 14	X						
Lubrication Points	Grease or Oil	Pages 14-15			X			X	
Hydrostatic Trans. Oil	Check Oil Level	Page 15				X		X	
Hydrostatic Trans. Filter	Replace Filter	Page 15	First Change at 200 Hours. Thereafter every 500 Hours.						

* Change oil every 25 hours when operating under heavy load or high temperatures.

**Clean more often under dusty conditions or when air debris is present

MAINTENANCE PARTS

4.7.6. MAINTENANCE/REPLACEMENT PARTS

MAINTENANCE/REPLACEMENT PARTS	52" MOWER DECK	61" MOWER DECK
Mower Blades	2-9246 (3)	2-9251 (3)
Mower Deck Belt	4-2776	3-5542
Upper Drive Shaft To Hydro Pump Belt	4-5254 (2)	
Deck Drive Shaft To Electric Clutch -Belt	3-5543 (2)	
Battery	3-5610	

SNAPPER®

2 YEAR LIMITED WARRANTY

For two (2) years from purchase date for the original purchaser's use, **SNAPPER**, through any authorized **SNAPPER** dealer will replace, free of charge (except for taxes where applicable), any part or parts found upon examination by the factory at McDonough, Georgia, to be defective in material or workmanship or both.

SNAPPER FIELD SERVICEABLE SPINDLES and their components used on **SNAPPER PRO**® Mid Size walks and **SNAPPERZRIDER**® ride on commercial equipment have a three (3) year limited warranty against defects in material or workmanship or both.

All transportation costs incurred by the purchaser in submitting material to an authorized **SNAPPER** dealer for replacement under this warranty must be paid by the purchaser.

This warranty does not apply to engines and their components, and batteries, as these items are warranted separately. This warranty does not apply to parts that have been damaged by accident, alteration, abuse, improper lubrication, normal wear, or other cause beyond the control of **SNAPPER**. This warranty does not cover any machine or component that has been altered or modified, changing safety, performance, or durability.

Batteries have a one (1) year prorated warranty period with free replacement if required during the first ninety (90) days from the original purchase date. **SNAPPER** will not be responsible for any installation cost incurred. The battery warranty only covers original equipment batteries and does not cover damage to the battery or machine caused by neglect or abuse, destruction by fire, explosion, freezing, overcharging, improper maintenance, or use of improper electrolyte.

There is no other express warranty.

DISCLAIMER OF WARRANTY

Implied warranties, including those of merchantability and fitness for a particular purpose, are limited to two (2) years from purchase date for the original purchaser's use, and up to the extent permitted by law and all implied warranties are excluded. This is the exclusive remedy. Liabilities for consequential damages, under any and all warranties are excluded.

Some states do not allow limitations on how long an implied warranty lasts, or do not allow the exclusion or limitation of incidental or consequential damages, so the above limitation or exclusion may not apply to you.

This warranty gives you specific legal rights, and you may also have other rights which vary from state to state.

WARNING: THE USE OF REPLACEMENT PARTS OTHER THAN GENUINE SNAPPER PARTS MAY IMPAIR THE SAFETY OF SNAPPER PRODUCTS AND WILL VOID ANY LIABILITY AND WARRANTY BY SNAPPER ASSOCIATED WITH THE USE OF SUCH PARTS.

IMPORTANT: Please fill out the attached **SNAPPER** Product Registration Card immediately and mail to:
Snapper's Product Registration Center, P.O. Box 1379, McDonough, Georgia. 30253

PRIMARY MAINTENANCE

SNAPPER®

VS. DIRT!

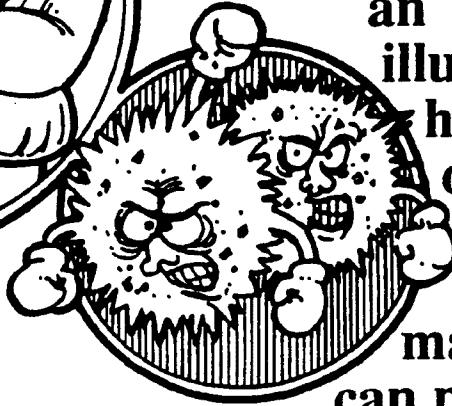
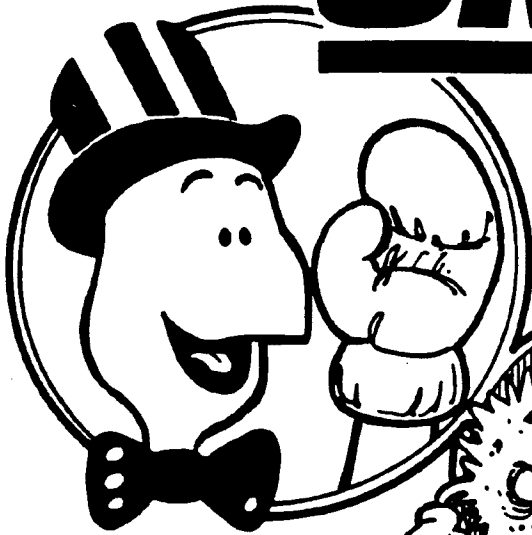

an illustration of how dirt can damage your engine & how reasonable maintenance can protect it!

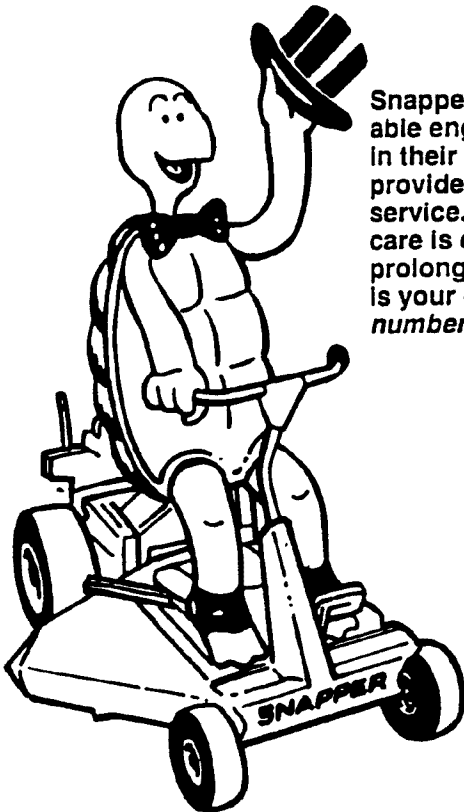

Snapper uses the best available engines and components in their products in order to provide long, satisfactory service. However, proper care is essential in prolonging engine life. Dirt is your engine's *enemy number 1!*

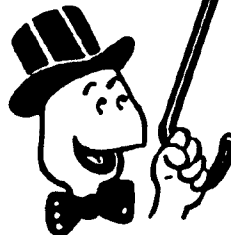
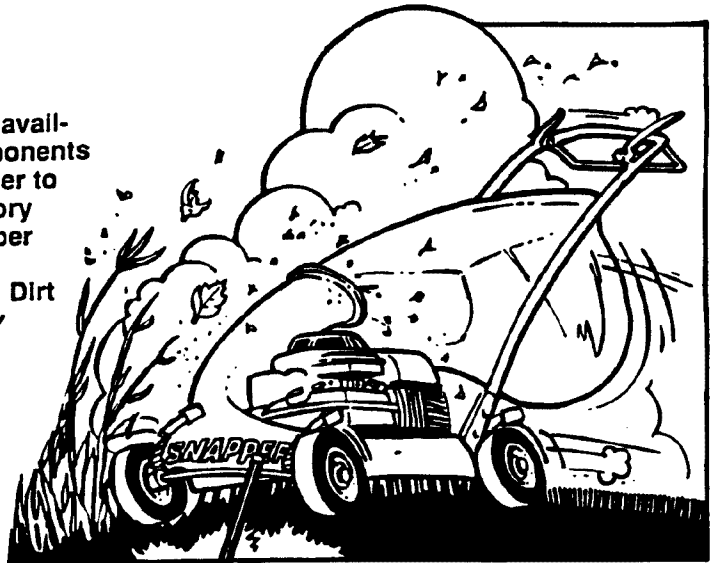

The engine on your Snapper product spends its entire life operating close to the ground at high speed creating a virtual storm of dust and dirt!

PRIMARY MAINTENANCE

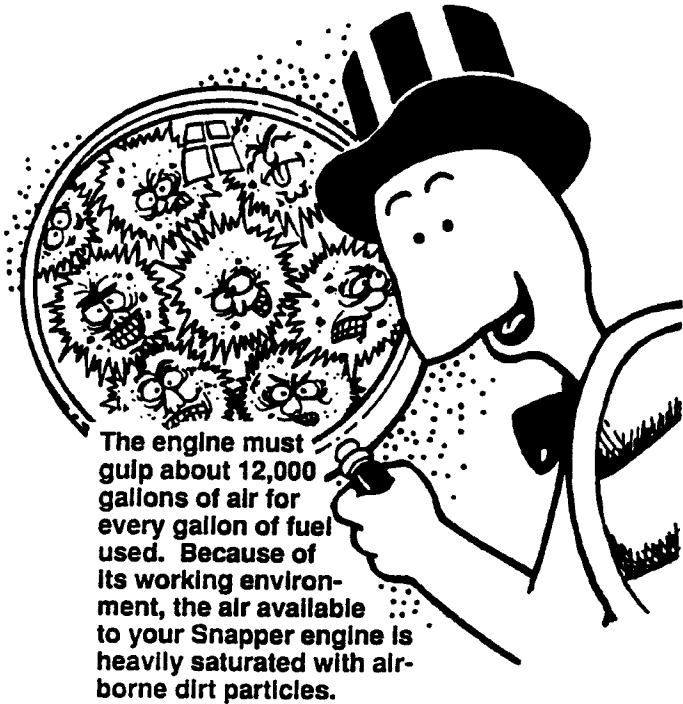

The engine must gulp about 12,000 gallons of air for every gallon of fuel used. Because of its working environment, the air available to your Snapper engine is heavily saturated with airborne dirt particles.

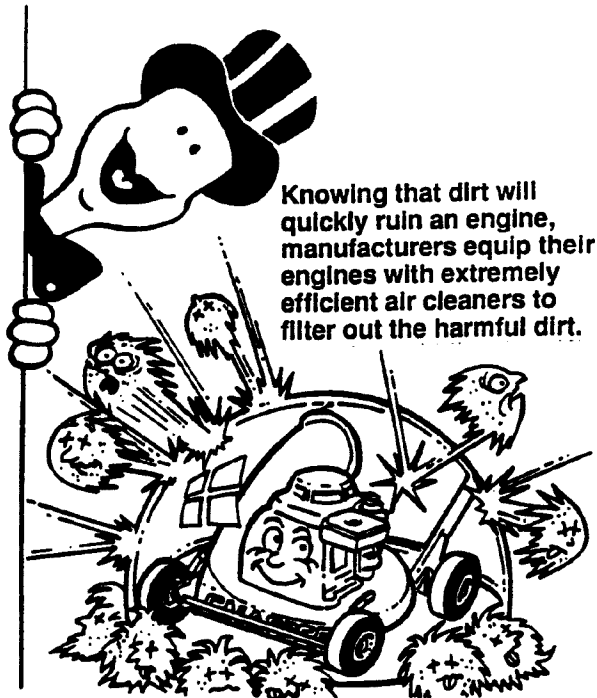

Knowing that dirt will quickly ruin an engine, manufacturers equip their engines with extremely efficient air cleaners to filter out the harmful dirt.

As the dirt particles are stopped, they build up and begin to clog the outside of the filter. This reduces the amount of air available to the engine and causes an over-rich fuel mixture which results in the following adverse effects:

An improperly serviced, dirt clogged air cleaner will:

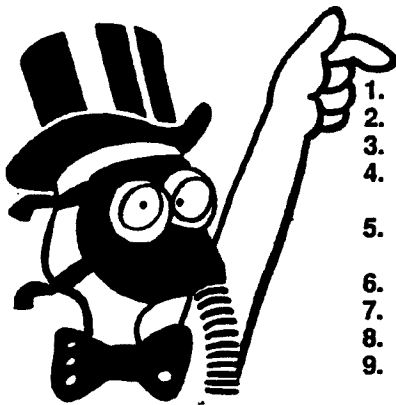

1. Increase fuel consumption
2. cause power loss
3. result in hard starting
4. create smoke from unburned fuel
5. produce carbon build-up internally
6. foul spark plug electrodes
7. score cylinder walls
8. burn valves
9. wear out the engine prematurely
10. COST YOU MONEY!

Damage caused by a poorly serviced air cleaner is not covered under the engine warranties. So, save yourself unnecessary expenses and undue aggravation by keeping the air cleaner properly serviced at the intervals specified in the engine owner's manual.

It doesn't take long to service an air cleaner. Follow the specific instructions in the engine owner's manual for the type filter used. Prevent dirt from falling into the carburetor intake when servicing your air cleaner. Make sure components are installed in correct sequence after servicing to prevent unfiltered air from entering the engine. Some servicing hints on several common types are:

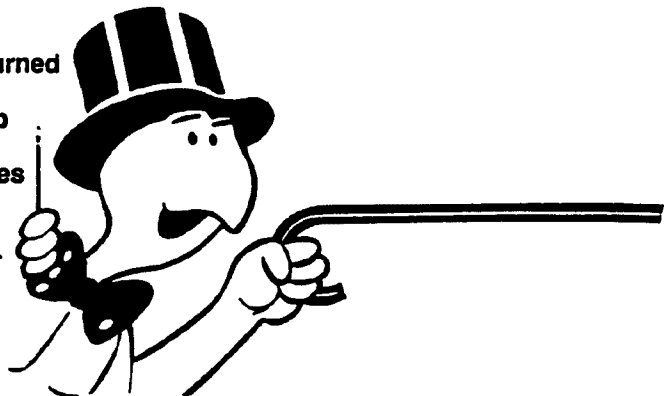

PRIMARY MAINTENANCE

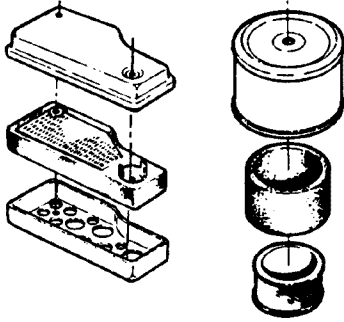

Generally, wash foam-type filters in a dishwashing detergent and water solution. Rinse and wring dry, then saturate with oil and squeeze out excess. *Failure to re-oil this type filter will ruin the engine.*

Clean paper elements by tapping lightly. Blowing with air will rupture paper elements.

Use a flashlight to detect clogged or torn paper elements - replace if damaged in any way.



Air is also needed to keep your engine cool. Dirt, dust & debris build up to restrict and clog cooling air intake screens and fins. Clean screens and fins at frequent intervals. The engine blower housing and shrouds should be removed at least once each season or more often under dry, dusty conditions for a thorough cleaning of fins.

Failure to keep external surfaces clean not only presents fire hazards, but causes overheating and resulting engine damages such as:

1. distorted valve guides
2. sticking valves
3. scuffed, scored cylinder walls
4. overspeeding
5. loss of power
6. complete failure of engine.

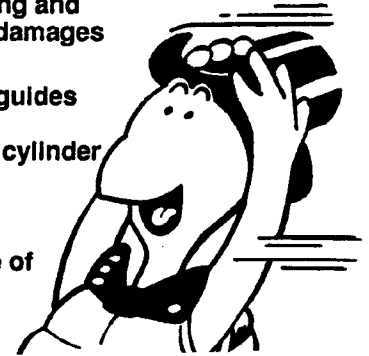

Dirt can also be introduced into an engine in dirty fuel from a contaminated container. Always use clean fresh fuel from a clean container to guard against dirt, sludge and water contamination.

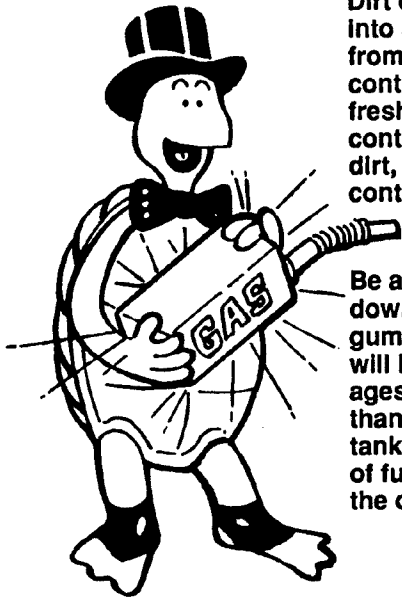

Be aware that fuel breaks down in storage and forms gummy compounds which will block carburetor passages. Never use fuel more than 3 months old. Drain tank then run the engine out of fuel before storing during the off-season.

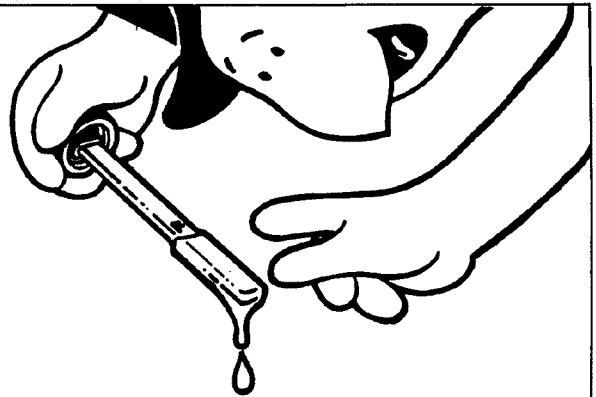

An engine must also have proper lubrication. All engines use some oil. On 4-cycle engines, **CHECK OIL LEVEL BEFORE EACH START-UP.** Wipe area clean around the oil check plug or dipstick opening to keep dirt from falling into the engine when checking the oil. Always check with the machine on a level surface. On engines with dipstick, keep the level up to, but not over, the **FULL** mark. When adding oil, allow time for all of the oil to flow down the fill tube to prevent a false full reading when the level could actually be low and result in engine damage.

PRIMARY MAINTENANCE

On 4-cycle engines with an oil level plug, don't be fooled into thinking the engine has sufficient lubricating oil if you can see "some" oil in the opening - the level should always be brought up to the point of overflowing at the top of the fill hole.

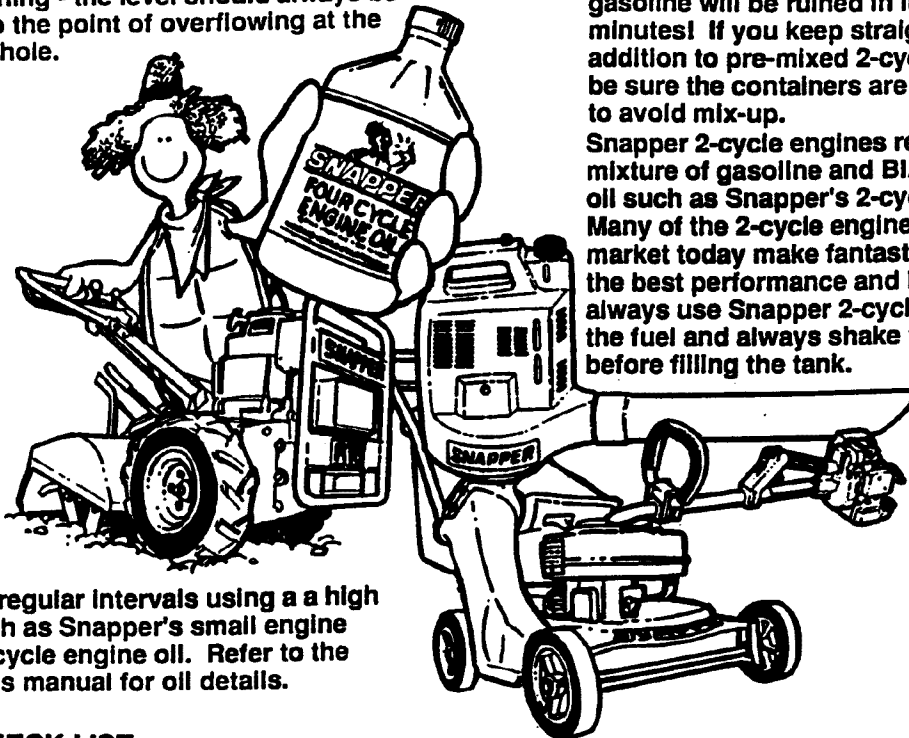
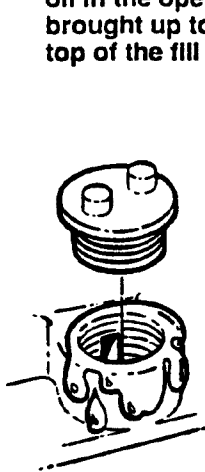

On 2-cycle engines, lubrication must be provided by an exact mixture of gasoline and 2-cycle air-cooled engine oil. A 2-cycle engine that is mistakenly run on straight gasoline will be ruined in less than 5 minutes! If you keep straight gasoline in addition to pre-mixed 2-cycle engine fuel, be sure the containers are clearly marked to avoid mix-up.

Snapper 2-cycle engines require a 32 to 1 mixture of gasoline and BIA certified TC-W oil such as Snapper's 2-cycle engine oil. Many of the 2-cycle engine oils on the market today make fantastic claims, but for the best performance and long engine life, always use Snapper 2-cycle oil. Pre-mix the fuel and always shake the container before filling the tank.

Change oil at regular intervals using a high quality oil such as Snapper's small engine formulated 4-cycle engine oil. Refer to the engine owner's manual for oil details.

STARTING CHECK LIST

- | | |
|-------------------------------|--|
| 1. Engine Oil | <ul style="list-style-type: none"> • To full level (4-cycle) • Properly mixed with gas (2 cycle) |
| 2. Air Cleaner | <ul style="list-style-type: none"> • Clean and properly serviced • Full fresh clean gasoline |
| 3. Fuel Tank | <ul style="list-style-type: none"> • Fuel valve open • Cap vent open • Inline filter clean |
| 4. Choke | <ul style="list-style-type: none"> • Operating properly |
| 5. Primer (on some engines) | <ul style="list-style-type: none"> • Used properly |
| 6. Safety Inter-lock Switches | <ul style="list-style-type: none"> • In proper position • All wires properly connected |
| 7. Switch & Blade Control | <ul style="list-style-type: none"> • Switch On • Blade control properly positioned on walk mower |
| 8. Spark plug | <ul style="list-style-type: none"> • Wire connected • Good connection • Start position |
| 9. Throttle control | |
| 10. Blade | <ul style="list-style-type: none"> • Properly installed and torqued • Sharpened |
| 11. Muffler | <ul style="list-style-type: none"> • Good condition • Not clogged • Grass & leaves cleaned away |

Read and follow all safety instructions in safety booklets and manuals.

Keep in mind that dirt is your engine's *enemy #1* both internally and externally! Internally, dirt will quickly ruin an engine and externally it will cause overheating and resulting internal damages. Damage caused by improper lubrication, poor air cleaner service or overheating due to dirt cannot be covered under warranty.

It only takes a few moments to service the engine (and equipment) on a routine basis but the rewards will be a quick starting, responsive engine that will provide long satisfactory service with minimum maintenance cost. The prestart checklist in the next column and instructions in your Snapper Operator's Manual are designated to help you keep your Snapper in top operating condition with minimum effort!

Safety Instructions & Operator's Manual for

SNAPPER®

MID MOUNT Z-RIDER

ZERO TURNING

HYDRO DRIVE

SERIES 1

IMPORTANT

Snapper products are built using engines that meet or exceed all applicable emissions requirements on the date manufactured. The labels on those engines contain very important emissions information and critical safety warnings. Read, Understand, and Follow all warnings and instructions in this manual, the engine manual, and on the machine, engine and attachments. If you have any questions about your Snapper product, contact your local authorized Snapper dealer or contact Snapper Customer Service at Snapper, McDonough, GA. 30253. Phone: (1-800-935-2967).



WARNING

BATTERY POSTS, TERMINALS AND RELATED ACCESSORIES CONTAIN LEAD AND LEAD COMPOUNDS, CHEMICALS KNOWN TO THE STATE OF CALIFORNIA TO CAUSE CANCER AND BIRTH DEFECTS OR OTHER REPRODUCTIVE HARM. WASH HANDS AFTER HANDLING.



WARNING

ENGINE EXHAUST, SOME OF ITS CONSTITUENTS, AND CERTAIN VEHICLE COMPONENTS CONTAIN OR EMIT CHEMICALS KNOWN TO THE STATE OF CALIFORNIA TO CAUSE CANCER OR OTHER REPRODUCTIVE HARM.

SNAPPER® McDonough, GA., 30253 U.S.A.