

WEIDERPRO™

290 W

Sears Model No. 831.15891.0
Kmart Model No. WEBE0938.0

Serial No. _____

Write the serial number in the space above for future reference.

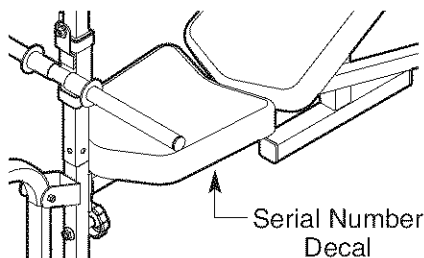

USER'S MANUAL

QUESTIONS?

As a manufacturer, we are committed to providing complete customer satisfaction. If you have questions, or if parts are missing, **PLEASE DO NOT CONTACT THE STORE; please contact Customer Care.**

IMPORTANT: You must note the product model number and serial number (see the drawing above) before contacting us:

SEARS CUSTOMERS:
1-800-4-MY-HOME®
(1-800-469-4663)

KMART CUSTOMERS:
1-877-992-5999
Mon.-Fri., 6 a.m.-6 p.m. MT
Sat. 8 a.m.-4 p.m. MT

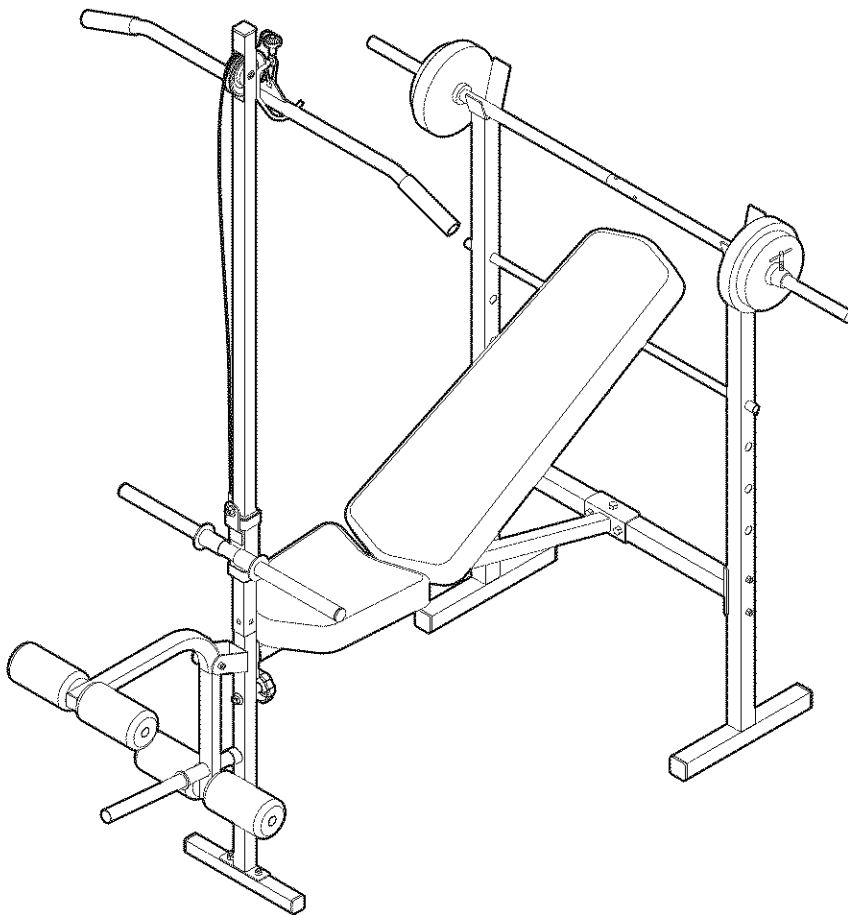

▲ CAUTION

Read all precautions and instructions in this manual before using this equipment. Save this manual for future reference.



Visit our website at

www.weiderfitness.com

new products, prizes,
fitness tips, and much more!

TABLE OF CONTENTS

WARNING DECAL PLACEMENT2

IMPORTANT PRECAUTIONS3

BEFORE YOU BEGIN4

PART IDENTIFICATION CHART5

ASSEMBLY6

ADJUSTMENT10

EXERCISE GUIDELINES12

PART LIST14

EXPLODED DRAWING15

ORDERING REPLACEMENT PARTSBack Cover

LIMITED WARRANTYBack Cover

WARNING DECAL PLACEMENT

This drawing shows the location(s) of the warning decal(s). **If a decal is missing or illegible, call the telephone number on the front cover of this manual and request a free replacement decal. Apply the decal in the location shown.** Note: The decal(s) may not be shown at actual size.

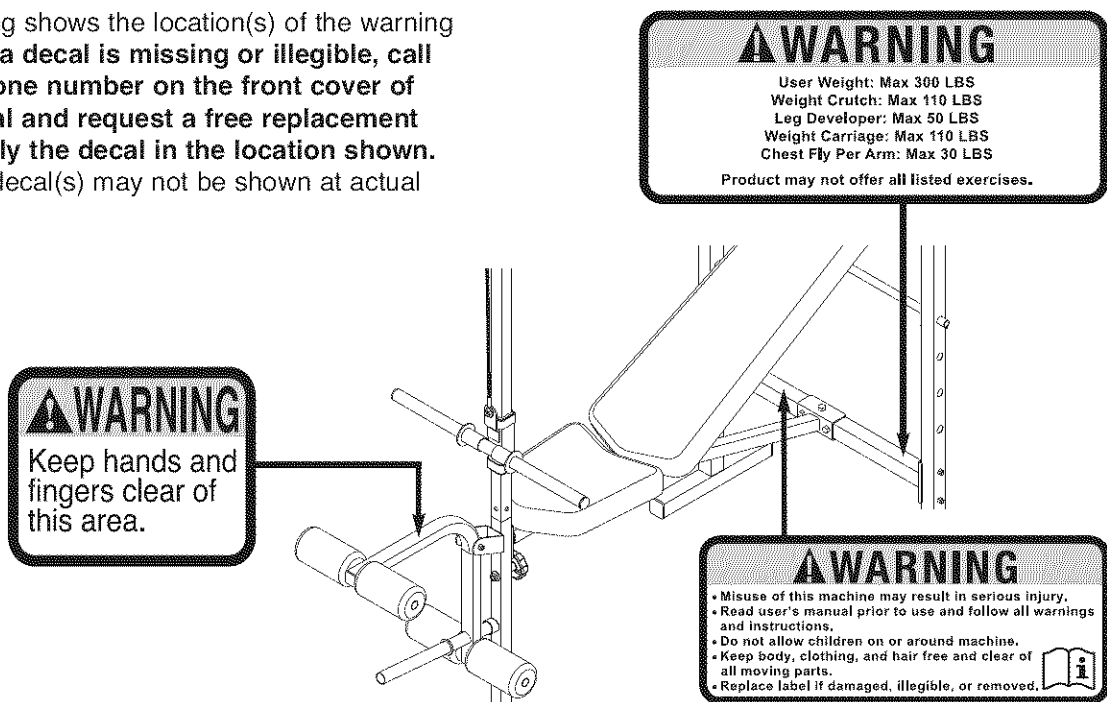

IMPORTANT PRECAUTIONS

⚠️ WARNING: To reduce the risk of serious injury, read all important precautions and instructions in this manual and all warnings on your weight bench before using your weight bench. ICON assumes no responsibility for personal injury or property damage sustained by or through the use of this product.

1. Before beginning any exercise program, consult your physician. This is especially important for persons over the age of 35 or persons with pre-existing health problems.
2. Use the weight bench only as described in this manual.
3. It is the responsibility of the owner to ensure that all users of the weight bench are adequately informed of all precautions.
4. The weight bench is intended for home use only. Do not use the weight bench in any commercial, rental, or institutional setting.
5. Keep the weight bench indoors, away from moisture and dust. Place the weight bench on a level surface, with a mat beneath it to protect the floor or carpet. Make sure that there is enough clearance around the weight bench to mount, dismount, and use the weight bench.
6. Inspect and properly tighten all parts regularly. Replace any worn parts immediately.
7. Keep children under age 12 and pets away from the weight bench at all times.
8. Keep hands and feet away from moving parts.
9. Always wear athletic shoes for foot protection while exercising.
10. The weight bench is designed to support a maximum user weight of 300 lbs. (136 kg) and a maximum total weight of 410 lbs. (186 kg). Do not place more than 110 lbs. (50 kg), including a barbell and weights, on the weight rests. Do not place more than 110 lbs. (50 kg) on the weight carriage. Do not place more than 50 lbs. (23 kg) on the leg lever.
11. Do not use a barbell that is longer than five ft. (1.5 m) with the weight bench.
12. Always make sure there is an equal amount of weight on each side of the barbell when you are using it. When adding or removing weights, always keep some weight on both ends of the barbell to prevent the barbell from tipping.
13. When you are using the leg lever, place a barbell with the same amount of weight on the weight rests to balance the bench.
14. When using the backrest in an inclined or level position, make sure that the backrest support is inserted completely through the uprights and turned to the locked position.
15. Always remove the curl post and the lat tower from the front leg before using the leg lever.
16. If you feel pain or dizziness at any time while exercising, stop immediately and begin cooling down.
17. Always exercise with a partner. Your partner should stand behind you to catch the barbell if you cannot complete a repetition.

BEFORE YOU BEGIN

Thank you for selecting the WEIDER PRO™ 290 W weight bench. The versatile 290 W weight bench is designed to develop every major muscle group of the body. Whether your goal is to tone your body, build dramatic muscle size and strength, or develop a healthier cardiovascular system, the weight bench will help you to achieve the specific results you want.

For your benefit, read this manual carefully before using the weight bench. If you have questions after

reading this manual, please see the front cover of this manual. To help us assist you, note the product model number and serial number before contacting us. The model number and the location of the serial number decal are shown on the front cover of this manual.

Before reading further, please review the drawing below and familiarize yourself with the labeled parts.

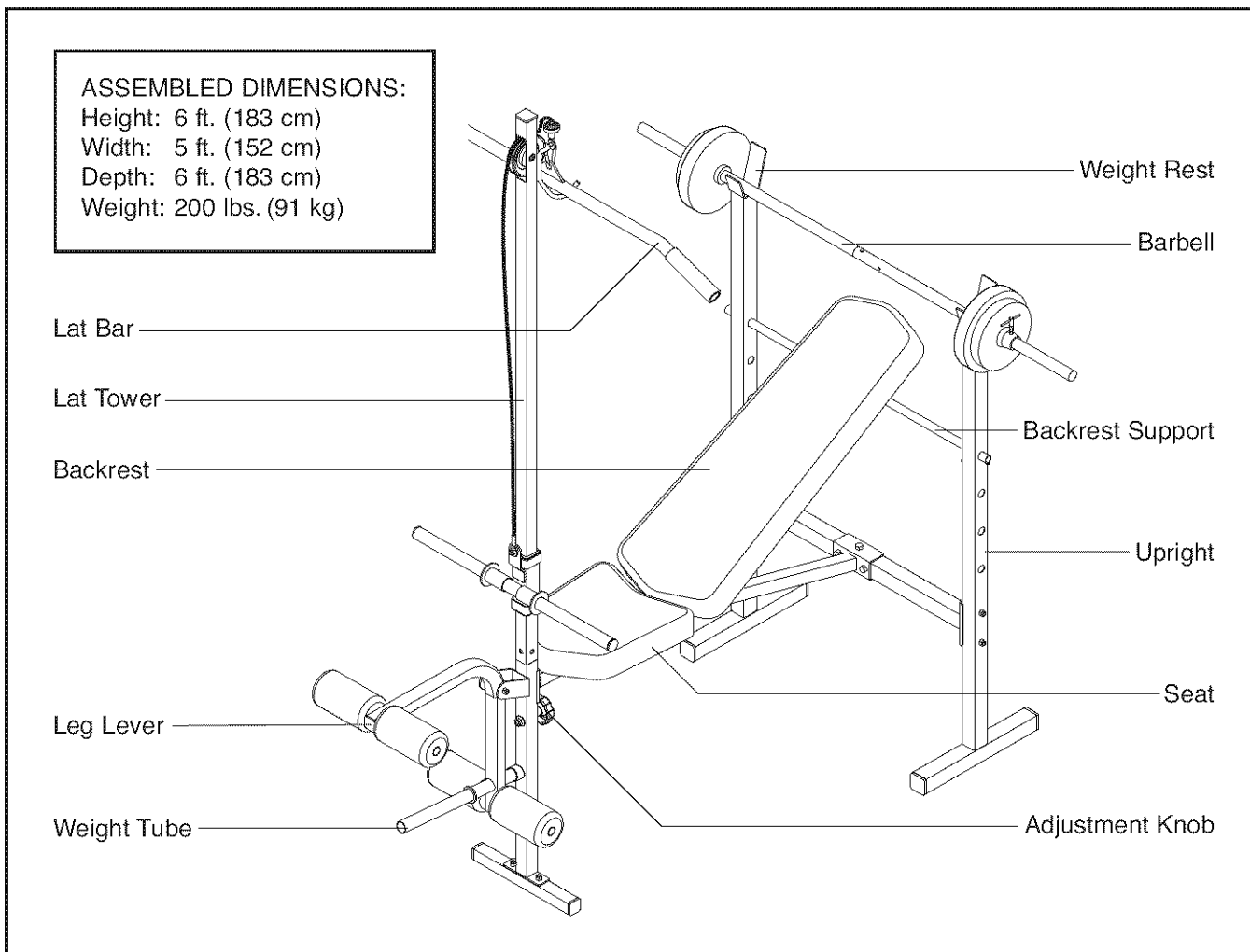

PART IDENTIFICATION CHART

This chart is provided to help you identify the small parts used in assembly. The number in parentheses below each part refers to the key number of the part from the PART LIST near the end of this manual. **Note: Some small parts may have been preattached. If a part is not in the hardware kit, check to see if it has been preattached.**

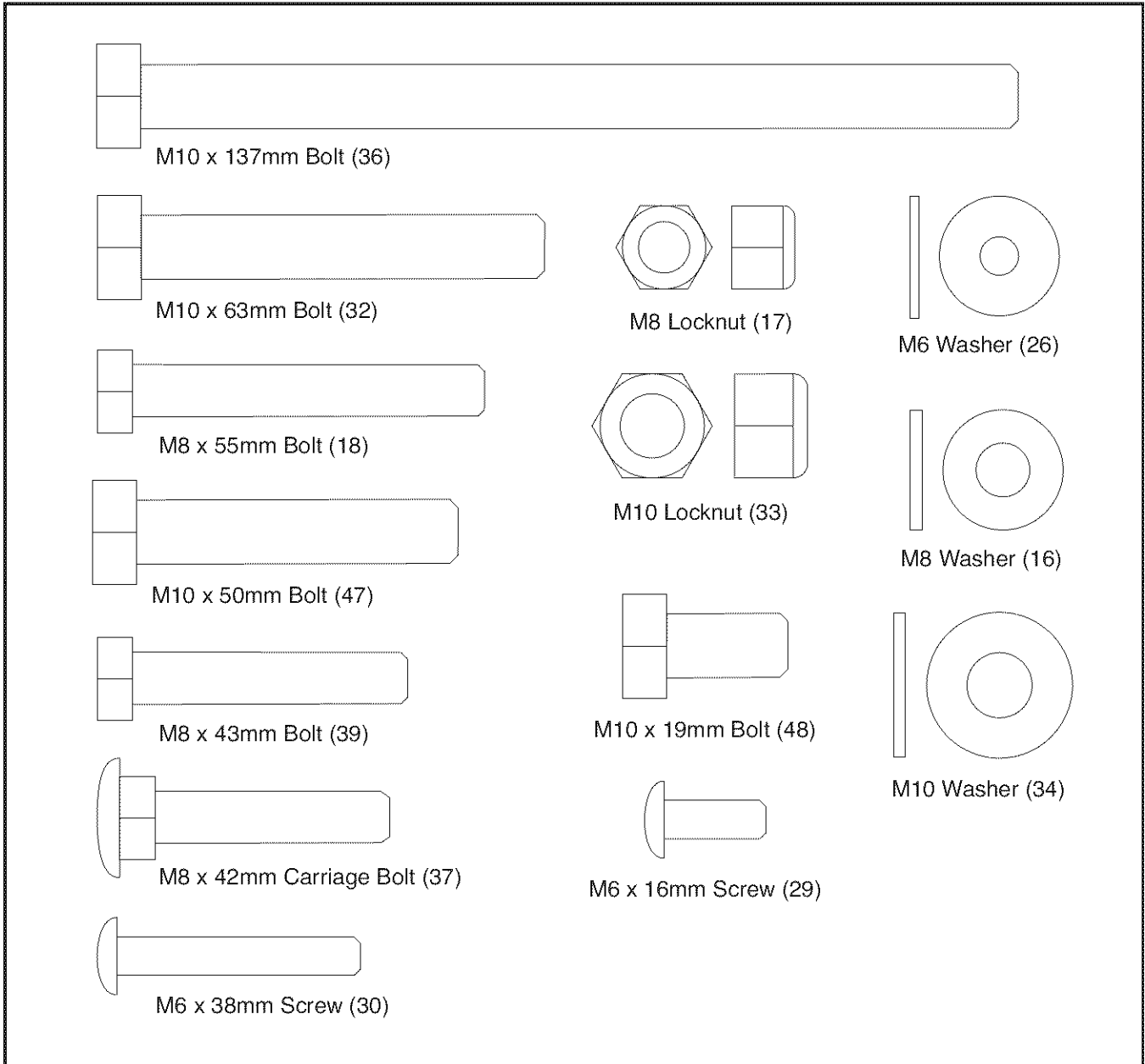

ASSEMBLY

Make Things Easier for Yourself

Everything in this manual is designed to ensure that the weight bench can be assembled successfully by almost anyone. Set aside plenty of time so that assembly will go smoothly.

Before beginning assembly, carefully read the following information and instructions:

- Assembly requires two people.
- Because of its size, the weight bench should be assembled in the location where it will be used. Make sure that there is enough clearance to walk around the weight bench as you assemble it.
- Place all parts in a cleared area and remove the packing materials. Do not dispose of the packing materials until assembly is completed.

- For help identifying small parts, use the PART IDENTIFICATION CHART on page 5.
- As you assemble the weight bench, make sure all parts are oriented as shown in the drawings.
- Tighten all parts as you assemble them, unless instructed to do otherwise.
- The included grease and the following tools (not included) may be required for assembly:

Two adjustable wrenches 

One hammer 

One standard screwdriver 

One Phillips screwdriver 

Assembly will be more convenient if you have a socket set, a set of open-end or closed-end wrenches, or a set of ratchet wrenches.

1. **Before assembling the weight bench, make sure that you have read and understand the information in the box above.**

Orient the Crossbar (3) so that the warning decals are on top. Attach the Crossbar to an Upright (1) with two M8 x 55mm Bolts (18), two M8 Washers (16), and two M8 Locknuts (17); **do not tighten the Locknuts yet.**

Attach the Crossbar (3) to the other Upright (1) in the same way.

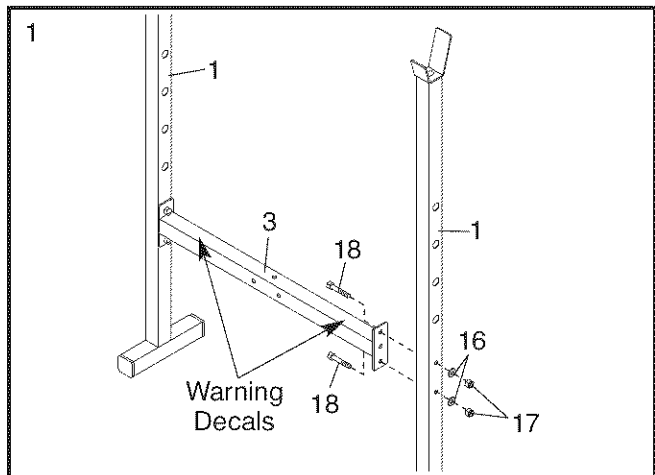

2. Orient the Stabilizer (13) so that the indented holes are facing the floor. Attach the Front Leg (8) to the Stabilizer with two M8 x 42mm Carriage Bolts (37) and two M8 Locknuts (17); **do not tighten the Locknuts yet.**

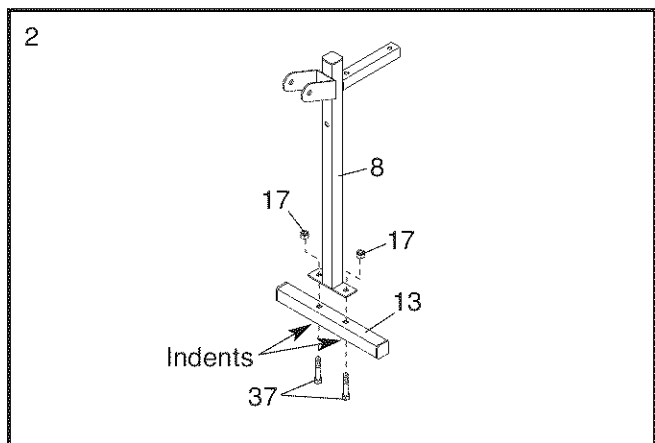

- Attach the Front Leg (8) to the Frame (2) with two M8 x 43mm Bolts (39), four M8 Washers (16), and two M8 Locknuts (17); **do not tighten the Locknuts yet.**

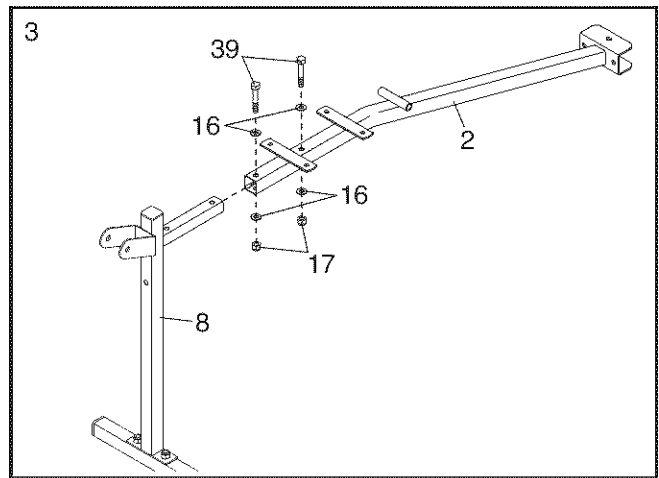

- Attach the Frame (2) to the Crossbar (3) with three M8 x 55mm Bolts (18), two M8 Washers (16), and three M8 Locknuts (17); **do not tighten the Locknuts yet.**

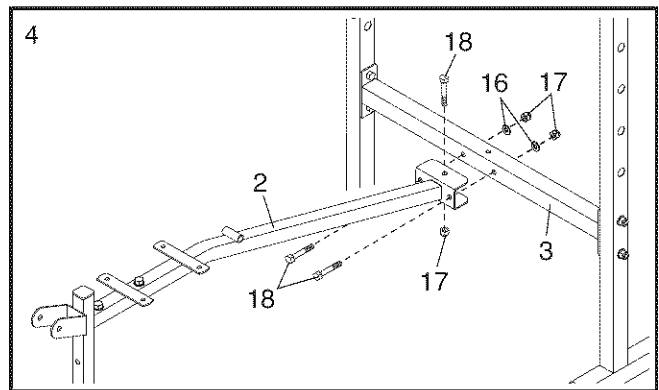

- Apply some of the included grease to an M10 x 63mm Bolt (32). Attach the Leg Lever (4) to the Front Leg (8) with the Bolt and an M10 Locknut (33). **Do not overtighten the Locknut; the Leg Lever must pivot easily.**

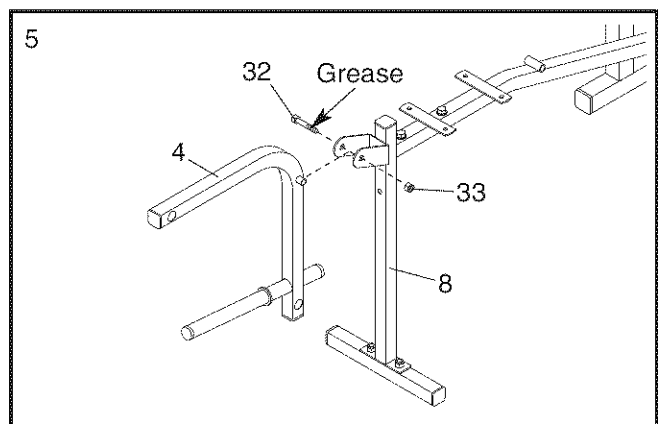

- Insert a Long Pad Tube (10) into a hole in the Leg Lever (4). Slide two Foam Pads (23) onto the Long Pad Tube.

Attach the other Long Pad Tube (10) and Foam Pads (23) in the same way.

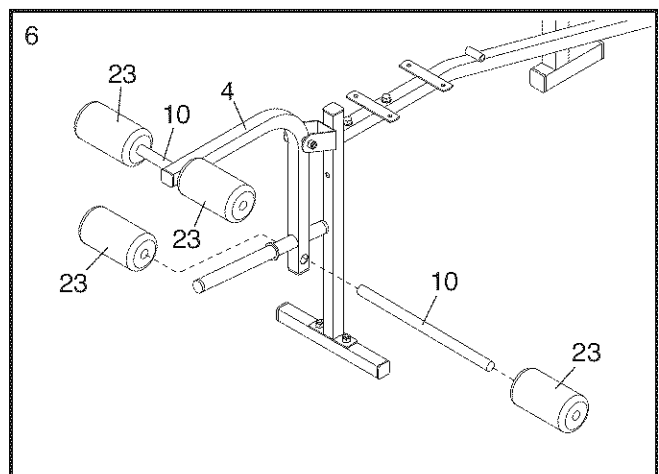

- Attach the Backrest Tubes (5) to the Backrest (6) with four M6 x 38mm Screws (30) and four M6 Washers (26); **do not tighten the Screws yet.**

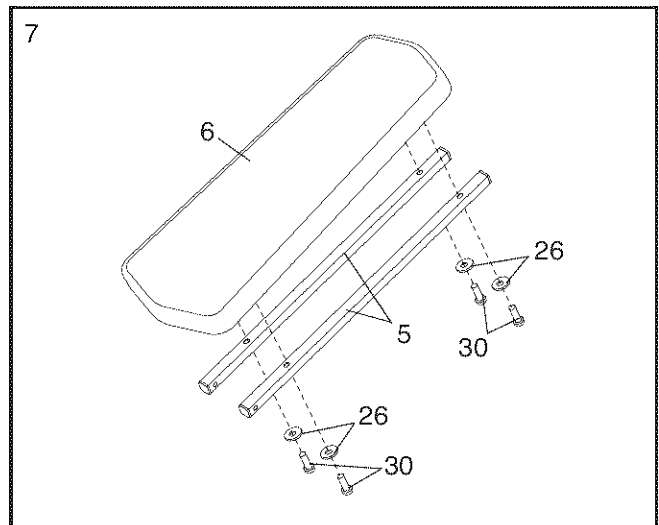

- Insert the Backrest Support (7) into a set of holes in the Uprights (1). Rotate the Backrest Support to the locked position, with the locking pin wrapped around the left Upright.

Grease an M10 x 137mm Bolt (36). Attach the Backrest Tubes (5) to the welded tube on the Frame (2) with the Bolt, two M10 Washers (34), and an M10 Locknut (33). **Do not overtighten the Locknut; the Backrest Tubes must pivot easily.**

See steps 1–4. Tighten the M8 Locknuts (17).
See step 7. Tighten the M6 x 38mm Screws (30).

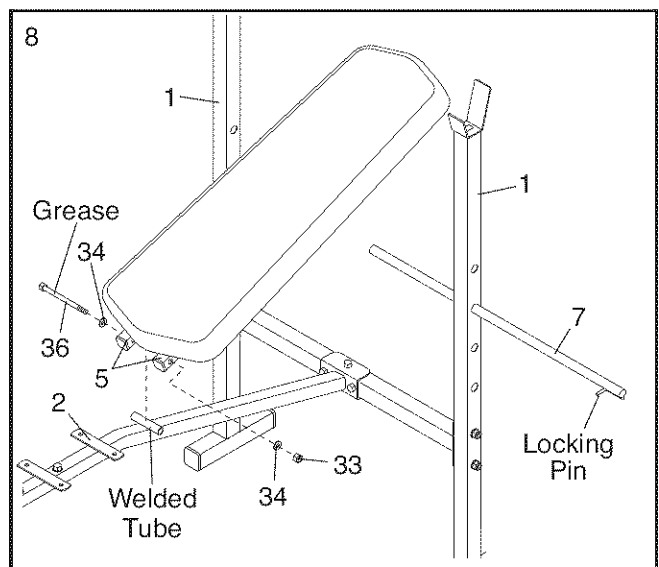

- Attach the Seat (11) to the Frame (2) with four M6 x 16mm Screws (29).

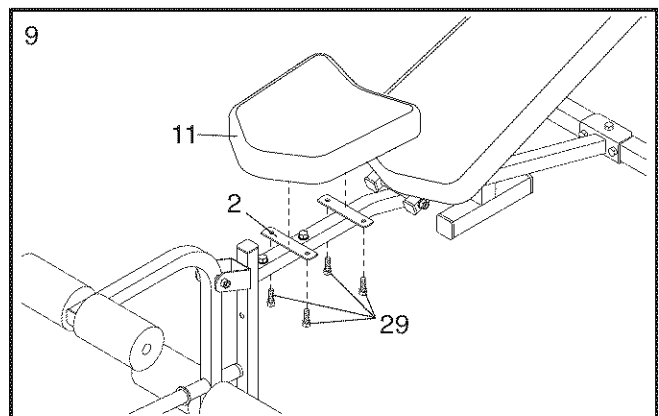

10. Attach the Curl Pad (45) to the Curl Post (27) with two M6 x 16mm Screws (29).

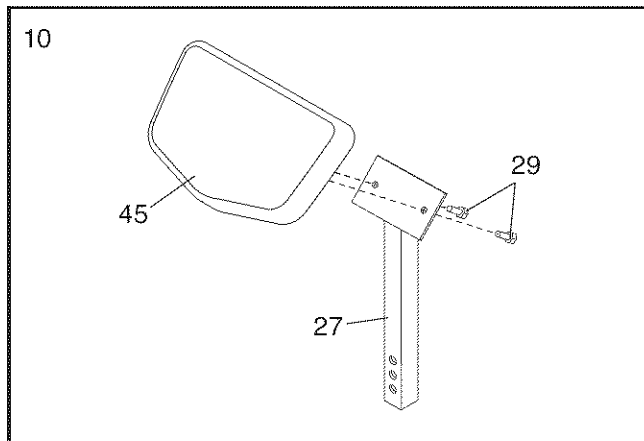

11. Route the Cable (19) through the Lat Tower (14) and over the Pulley (25). **Make sure that the Cable is under the lat bar rest.** Attach the Pulley inside the Lat Tower with an M10 x 50mm Bolt (47), two M10 Washers (34), two 10mm Large Spacers (49), and an M10 Locknut (33).

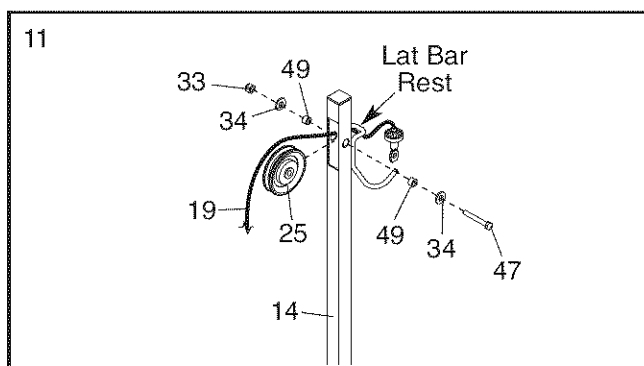

12. Insert an M10 x 19mm Bolt (48) into the bracket on the Weight Carriage (12).

Slide the Weight Carriage (12) onto the Lat Tower (14). **Make sure that the bracket on the Weight Carriage and the lat bar rest (see step 11) on the Lat Tower are on opposite sides of the Lat Tower.** Attach the Cable (19) to the M10 x 19mm Bolt (48) with an M10 Locknut (33).

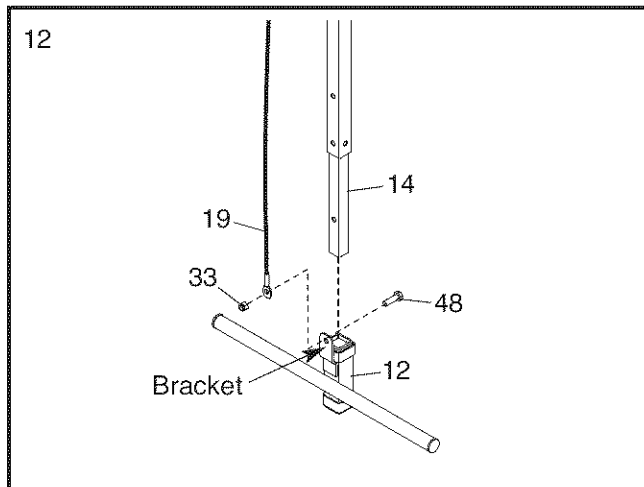

13. Insert the Inner Bar (43) into the Outer Bar (40) and align the indicated holes. Using a hammer, tap the two Roll Pins (41) into the holes until they are flush with the Outer Bar.

14. **Make sure that all parts are properly tightened before the weight bench is used.** Note: Some hardware may be left over after assembly is completed. The use of all remaining parts will be explained in ADJUSTMENT, starting on page 10.

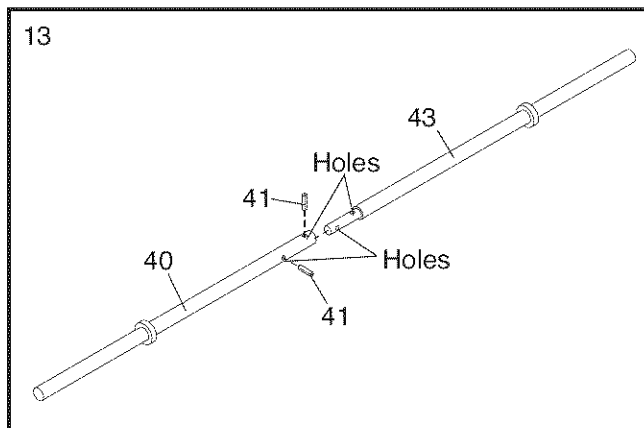

ADJUSTMENT

The steps below explain how the weight bench can be adjusted. See the accompanying exercise guide to see the correct form for several exercises.

Make sure all parts are properly tightened each time the weight bench is used. Replace any worn parts immediately. Clean the weight bench with a damp cloth and a mild, non-abrasive detergent; **do not use solvents to clean the weight bench.**

ADJUSTING THE BACKREST

The Backrest (6) can be used in a declined position, a level position, or any of three inclined positions. To use the Backrest in a declined position, remove the Backrest Support (7) and lay the Backrest on the Crossbar (3).

To use the Backrest (6) in a level position or an inclined position, insert the Backrest Support (7) into a set of holes in the Uprights (1). Rotate the Backrest Support to the locked position, with the locking pin wrapped around the left Upright. Rest the Backrest on the Backrest Support.

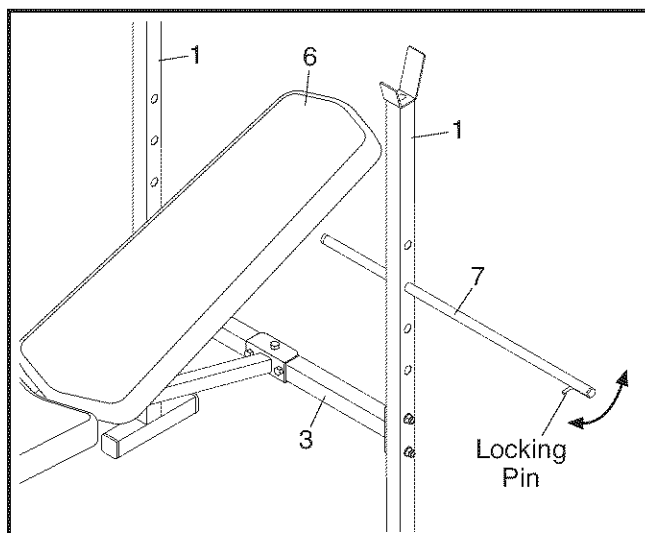

ATTACHING WEIGHTS TO THE WEIGHT CARRIAGE OR THE LEG LEVER

To use the Weight Carriage (12), first slide the Weight Spacers (52) onto the Weight Carriage as shown. Next, slide the desired Weights (38, 44) onto the Weight Carriage. **Then, slide the two Small Weight Collars (51) against the Weights, and fully tighten the Small Weight Collars.**

To use the Leg Lever (4), slide the desired Weights (38, 44) onto the weight tube on the Leg Lever.

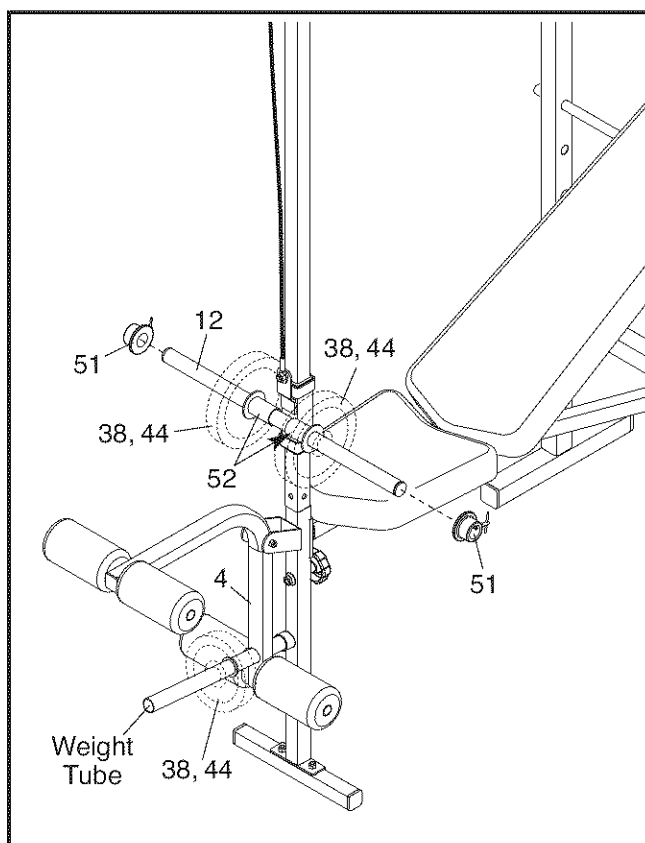

WARNING: Do not place more than 110 lbs. (50 kg) on the Weight Carriage (12). Always secure the Weights (38, 44) on the Weight Carriage with the Small Weight Collars (51).

Do not place more than 50 lbs. (23 kg) on the Leg Lever (4). When using the Leg Lever, place a barbell with the same amount of weight on the weight rests to balance the bench.

ATTACHING WEIGHTS TO THE BARBELL

Slide an equal amount of Weight (38, 44) onto each end of the barbell. Then, slide the two Large Weight Collars (42) against the Weights, and fully tighten the Large Weight Collars.

WARNING: Do not place more than 100 lbs. (45 kg) on the barbell. Always secure the Weights (38, 44) on the barbell with the Large Weight Collars (42).

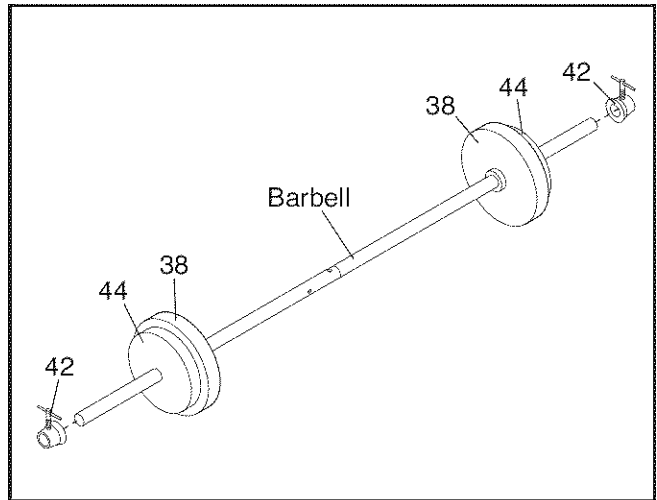

ATTACHING THE CURL PAD OR THE LAT TOWER

For some exercises, the Curl Pad (45) must be attached to the weight bench. Remove the 30mm Square Inner Cap (22) from the Front Leg (8). Insert the Curl Post (27) into the Front Leg, and align an adjustment hole in the Curl Post with the adjustment hole in the Front Leg. Secure the Curl Post with the Curl Knob (31).

The Lat Tower (14) can be attached in the same way.

Note: When the Curl Pad (45) or the Lat Tower (14) are not being used, store them away from the weight bench, and insert the 30mm Square Inner Cap (22) into the Front Leg (8).

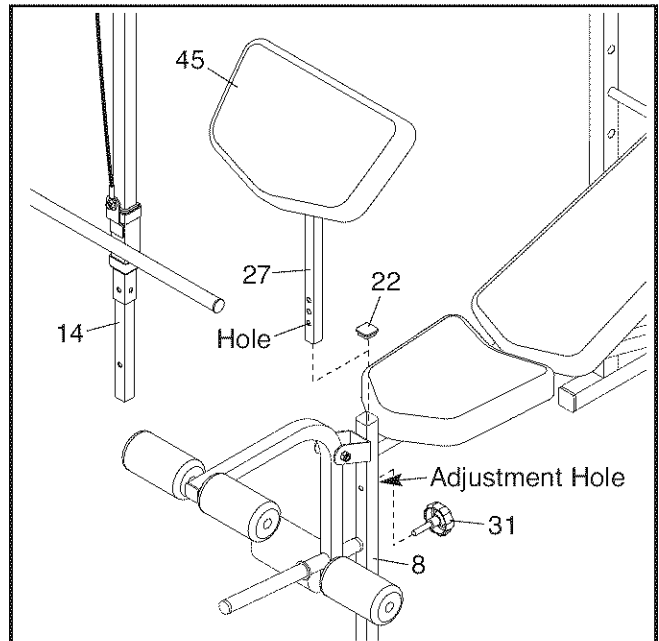

ATTACHING THE LAT BAR

Attach the Lat Bar (15) to the Cable (19) with a Cable Clip (50). Remove the Lat Bar when performing an exercise that does not require it.

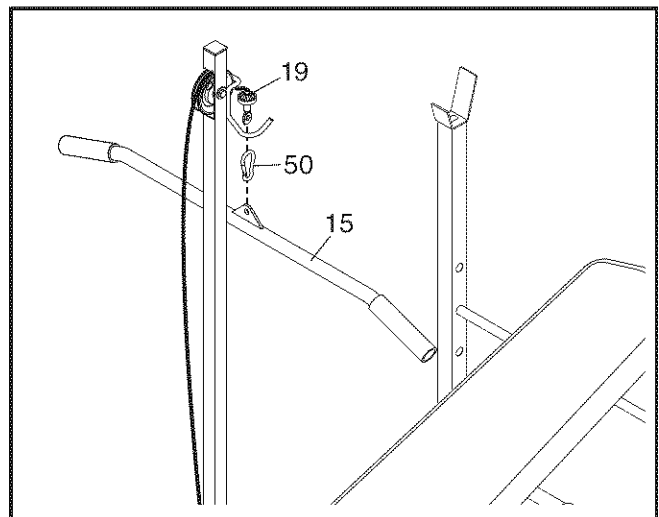

EXERCISE GUIDELINES

THE FOUR BASIC TYPES OF WORKOUTS

Muscle Building

To increase the size and strength of your muscles, push them close to their maximum capacity. Your muscles will continually adapt and grow as you progressively increase the intensity of your exercise. You can adjust the intensity level of an individual exercise in two ways:

- by changing the amount of resistance used
- by changing the number of repetitions or sets performed. (A “repetition” is one complete cycle of an exercise, such as one sit-up. A “set” is a series of repetitions.)

The proper amount of resistance for each exercise depends upon the individual user. You must gauge your limits and select the amount of resistance that is right for you. Begin with 3 sets of 8 repetitions for each exercise you perform. Rest for 3 minutes after each set. When you can complete 3 sets of 12 repetitions without difficulty, increase the amount of resistance.

Toning

You can tone your muscles by pushing them to a moderate percentage of their capacity. Select a moderate amount of resistance and increase the number of repetitions in each set. Complete as many sets of 15 to 20 repetitions as possible without discomfort. Rest for 1 minute after each set. Work your muscles by completing more sets rather than by using high amounts of resistance.

Weight Loss

To lose weight, use a low amount of resistance and increase the number of repetitions in each set. Exercise for 20 to 30 minutes, resting for a maximum of 30 seconds between sets.

Cross Training

Cross training is an efficient way to get a complete and well-balanced fitness program. An example of a balanced program follows:

- Plan strength training workouts on Monday, Wednesday, and Friday.
- Plan 20 to 30 minutes of aerobic exercise, such as running on a treadmill or riding on an elliptical exerciser or exercise cycle, on Tuesday and Thursday.
- Rest from both strength training and aerobic exercise for at least one full day each week to give your body time to regenerate.

The combination of strength training and aerobic exercise will reshape and strengthen your body, plus develop your heart and lungs.

PERSONALIZING YOUR EXERCISE PROGRAM

Determining the appropriate length of time for each workout, and the numbers of repetitions and sets to complete, is an individual matter. Avoid overdoing it during the first few months of your exercise program. Progress at your own pace and be sensitive to your body’s signals. If you experience pain or dizziness while exercising, stop immediately and cool down. Find out what is wrong before continuing. Remember that adequate rest and a proper diet are important factors in any exercise program.

WARMING UP

Begin each workout with 5 to 10 minutes of stretching and light exercise to warm up. Warming up prepares your body for more strenuous exercise by increasing circulation, raising your body temperature, and delivering more oxygen to your muscles.

WORKING OUT

Each workout should include 6 to 10 different exercises. Select exercises for every major muscle group, emphasizing areas that you want to develop most. To give balance and variety to your workouts, vary the exercises from workout to workout.

Schedule your workouts for the time of day when your energy level is the highest. Each workout should be followed by at least one day of rest. Once you find the schedule that is right for you, stick with it.

EXERCISE FORM

Maintaining proper form is an essential part of an effective exercise program. This requires moving through the full range of motion for each exercise, and moving only the appropriate parts of the body. Exercising in an uncontrolled way will leave you feeling exhausted. On the exercise guide accompanying this manual you will find photographs showing the correct form for several exercises, and a list of the muscles affected. See the muscle chart on the next page to find the names of the muscles.

The repetitions in each set should be performed smoothly and without pausing. The exertion stroke of each repetition should last about half as long as the return stroke. Proper breathing is important. Exhale during the exertion stroke of each repetition and inhale during the return stroke. Never hold your breath.

Rest for a short period of time after each set. The ideal resting periods follow:

- Rest for three minutes after each set for a muscle building workout.
- Rest for one minute after each set for a toning workout.
- Rest for 30 seconds after each set for a weight loss workout.

Plan to spend the first couple of weeks familiarizing yourself with the equipment and learning the proper form for each exercise.

COOLING DOWN

End each workout with 5 to 10 minutes of stretching. Include stretches for both your arms and legs. Move slowly as you stretch and do not bounce. Ease into each stretch gradually and go only as far as you can without strain. Stretching at the end of each workout is an effective way to increase flexibility.

STAYING MOTIVATED

For motivation, keep a record of each workout. Write the date, the exercises performed, the resistance used, and the numbers of sets and repetitions completed. Record your weight and key body measurements at the end of every month. The key to achieving the greatest results is to make exercise a regular and enjoyable part of your everyday life.

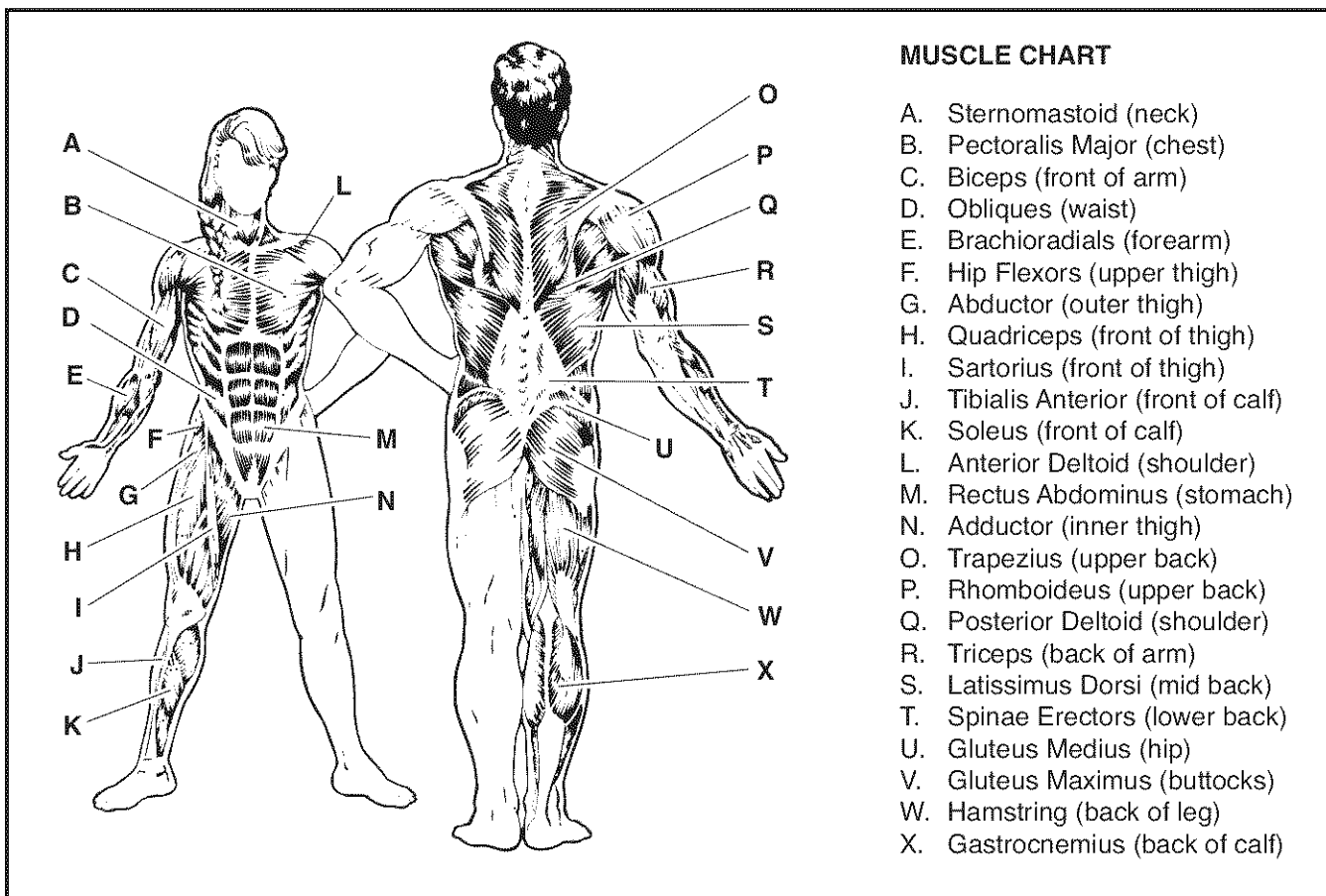

MUSCLE CHART

- A. Sternomastoid (neck)
- B. Pectoralis Major (chest)
- C. Biceps (front of arm)
- D. Obliques (waist)
- E. Brachioradials (forearm)
- F. Hip Flexors (upper thigh)
- G. Abductor (outer thigh)
- H. Quadriceps (front of thigh)
- I. Sartorius (front of thigh)
- J. Tibialis Anterior (front of calf)
- K. Soleus (front of calf)
- L. Anterior Deltoid (shoulder)
- M. Rectus Abdominus (stomach)
- N. Adductor (inner thigh)
- O. Trapezius (upper back)
- P. Rhomboideus (upper back)
- Q. Posterior Deltoid (shoulder)
- R. Triceps (back of arm)
- S. Latissimus Dorsi (mid back)
- T. Spinae Erectors (lower back)
- U. Gluteus Medius (hip)
- V. Gluteus Maximus (buttocks)
- W. Hamstring (back of leg)
- X. Gastrocnemius (back of calf)

Key No.	Qty.	Description	Key No.	Qty.	Description
1	2	Upright	29	6	M6 x 16mm Screw
2	1	Frame	30	4	M6 x 38mm Screw
3	1	Crossbar	31	1	Curl Knob
4	1	Leg Lever	32	1	M10 x 63mm Bolt
5	2	Backrest Tube	33	4	M10 Locknut
6	1	Backrest	34	4	M10 Washer
7	1	Backrest Support	35	4	25mm Square Inner Cap
8	1	Front Leg	36	1	M10 x 137mm Bolt
9	6	19mm Round Inner Cap	37	2	M8 x 42mm Carriage Bolt
10	2	Long Pad Tube	38	4	15-pound Weight
11	1	Seat	39	2	M8 x 43mm Bolt
12	1	Weight Carriage	40	1	Outer Bar
13	1	Stabilizer	41	2	Roll Pin
14	1	Lat Tower	42	2	Large Weight Collar
15	1	Lat Bar	43	1	Inner Bar
16	10	M8 Washer	44	2	10-lb. Weight
17	11	M8 Locknut	45	1	Curl Pad
18	7	M8 x 55mm Bolt	46	2	Lat Tower Bushing
19	1	Cable	47	1	M10 x 50mm Bolt
20	1	25mm Round Angled Cap	48	1	M10 x 19mm Bolt
21	4	38mm Square Inner Cap	49	2	10mm Large Spacer
22	6	30mm Square Inner Cap	50	1	Cable Clip
23	4	Foam Pad	51	2	Small Weight Collar
24	7	25mm Round Inner Cap	52	2	Weight Spacer
25	1	Pulley	*	—	User's Manual
26	4	M6 Washer	*	—	Exercise Guide
27	1	Curl Post	*	—	Grease Packet
28	2	Lat Handgrip			

Note: Specifications are subject to change without notice. See the back cover of this manual for information about ordering replacement parts. *These parts are not illustrated.

EXPLODED DRAWING SEARS MODEL NO. 831.15891.0; KMART MODEL NO. WEBE0938.0

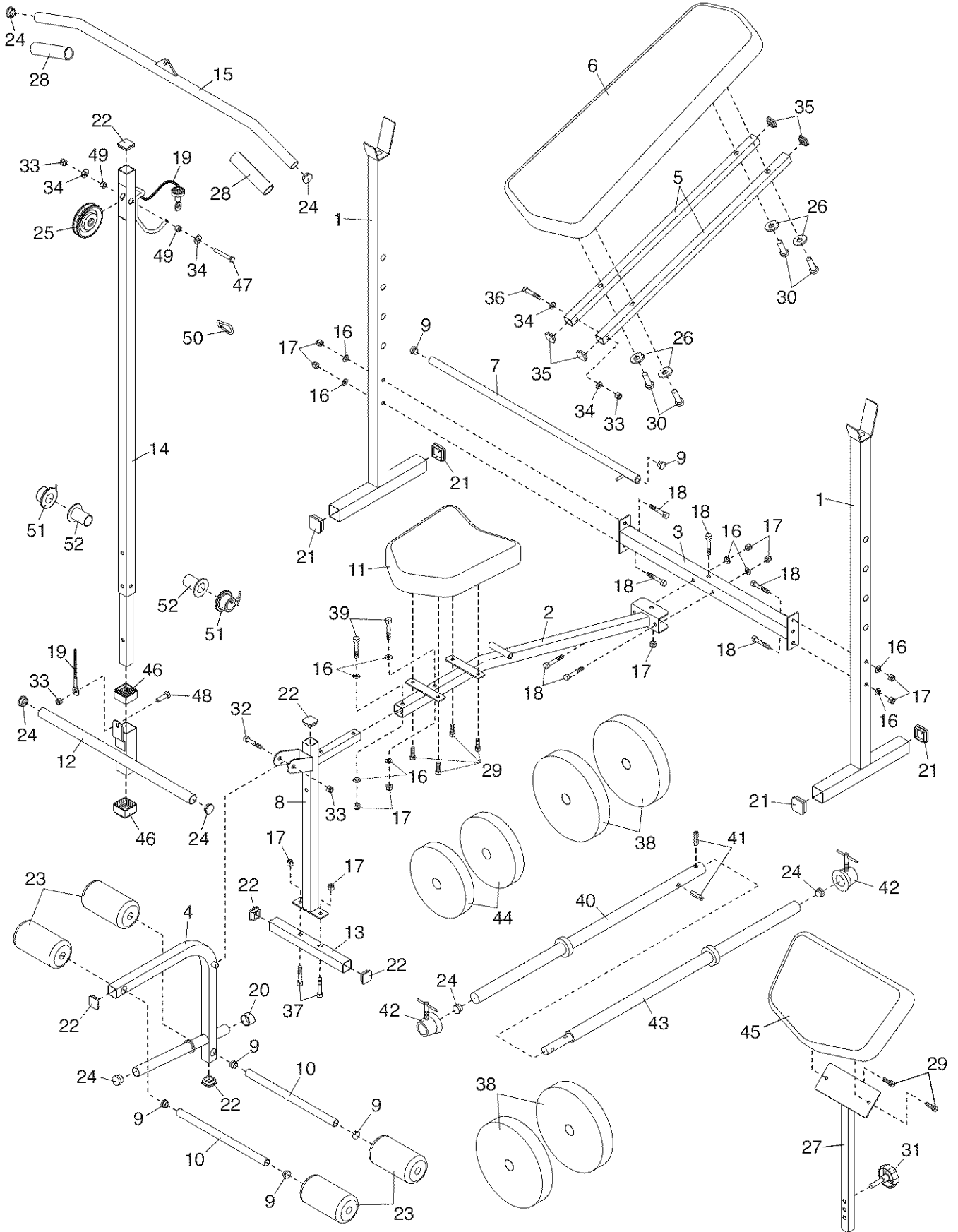

R0608A

ORDERING REPLACEMENT PARTS

To order replacement parts, please see the front cover of this manual. To help us assist you, be prepared to provide the following information when contacting us:

- the model number and serial number of the product (see the front cover of this manual)
- the name of the product (see the front cover of this manual)
- the key number and description of the replacement part(s) (see the PART LIST and the EXPLODED DRAWING near the end of this manual)

LIMITED WARRANTY

ICON Health & Fitness, Inc. (ICON) warrants this product to be free from defects in workmanship and material, under normal use and service conditions. Parts and labor are warranted for ninety (90) days from the date of purchase.

This warranty extends only to the original purchaser. ICON's obligation under this warranty is limited to repairing or replacing, at ICON's option, the product through one of its authorized service centers. All repairs for which warranty claims are made must be preauthorized by ICON. If the product is shipped to a service center, freight charges to and from the service center will be the customer's responsibility. For replacement parts shipped while the product is under warranty, the customer will be responsible for a minimal handling charge. For in-home service, the customer will be responsible for a minimal trip charge. This warranty does not extend to any damage to a product caused by or attributable to freight damage, abuse, misuse, improper or abnormal usage, or repairs not provided by an ICON authorized service center; products used for commercial or rental purposes; or products used as store display models. No other warranty beyond that specifically set forth above is authorized by ICON.

ICON is not responsible or liable for indirect, special, or consequential damages arising out of or in connection with the use or performance of the product; damages with respect to any economic loss, loss of property, loss of revenues or profits, loss of enjoyment or use, or costs of removal or installation; or other consequential damages of whatsoever nature. Some states do not allow the exclusion or limitation of incidental or consequential damages. Accordingly, the above limitation may not apply to you.

The warranty extended hereunder is in lieu of any and all other warranties, and any implied warranties of merchantability or fitness for a particular purpose are limited in their scope and duration to the terms set forth herein. Some states do not allow limitations on how long an implied warranty lasts. Accordingly, the above limitation may not apply to you.

This warranty gives you specific legal rights. You may also have other rights that vary from state to state.

ICON Health & Fitness, Inc., 1500 S. 1000 W., Logan, UT 84321-9813