

PRO-FORM[®] CROSSWALK 480

Model No. 831.24824.1

Serial No. _____

Write the serial number in the space above for future reference.

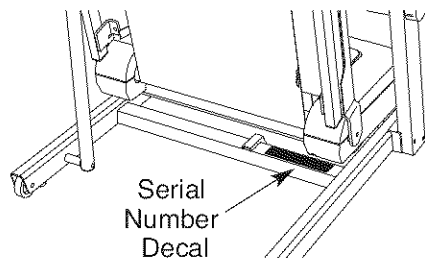

- Assembly
- Operation
- Maintenance
- Part List and Drawing

⚠ CAUTION

Read all precautions and instructions in this manual before using this equipment. Save this manual for future reference.

TREADMILL EXERCISER User's Manual

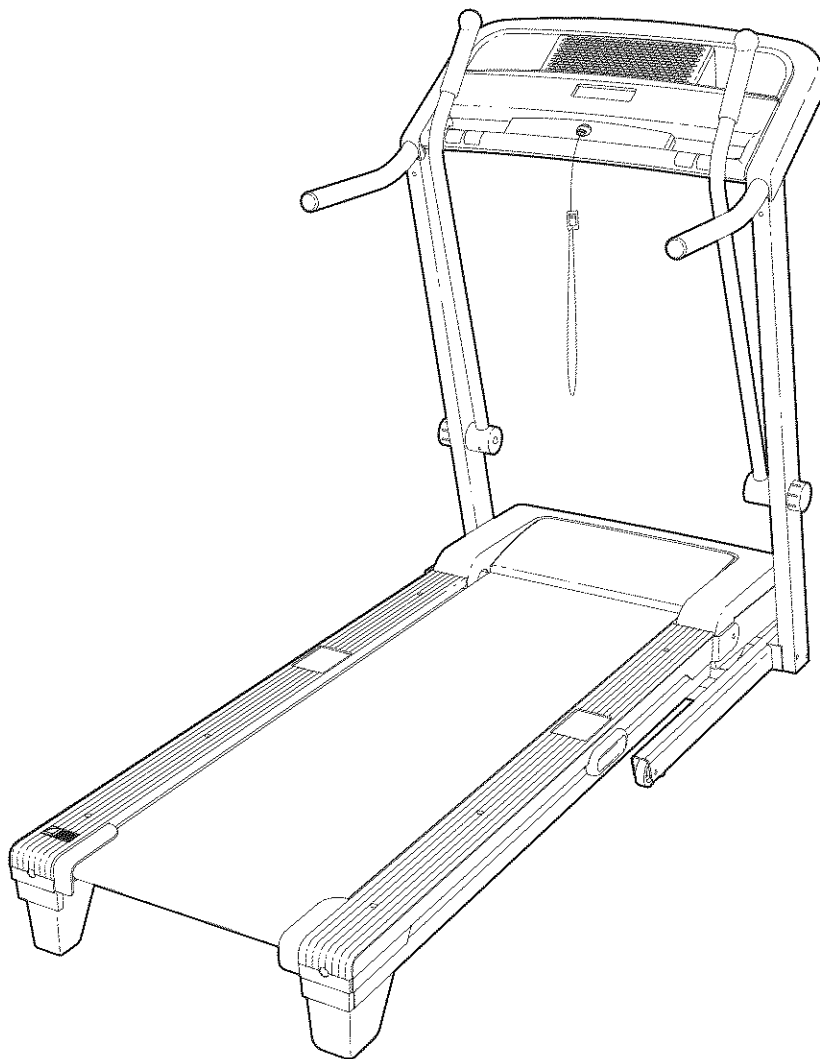

Sears, Roebuck and Co., Hoffman Estates, IL 60179

TABLE OF CONTENTS

WARNING DECAL PLACEMENT2

IMPORTANT PRECAUTIONS3

BEFORE YOU BEGIN5

ASSEMBLY6

OPERATION AND ADJUSTMENT14

HOW TO FOLD AND MOVE THE TREADMILL20

TROUBLESHOOTING22

EXERCISE GUIDELINES25

PART LIST26

EXPLODED DRAWING28

ORDERING REPLACEMENT PARTSBack Cover

90 DAY FULL WARRANTYBack Cover



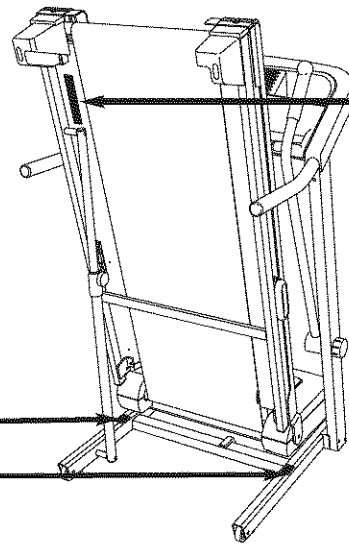

WARNING DECAL PLACEMENT

This drawing shows the locations of the warning decals. If a decal is missing or illegible, call 1-888-533-1333 and request a free replacement decal. Apply the decal in the location shown. Note: The decals may not be shown at actual size.



WARNING:

Protect yourself and others from risk of serious injury. Read the user's manual and :

-  •Stand only on the side rails when starting or stopping treadmill.
- Change speed in small increments.
- Hold handrails to prevent falling, and always wear the safety clip while operating treadmill.
- Stop if you feel faint, dizzy, or short of breath.
- Fully engage storage latch before treadmill is moved or stored.
- Reduce incline to its lowest level before folding treadmill into storage position.
-  •Never allow children on or around treadmill.
- Remove key when not in use.
-  •Keep clothing, fingers, and hair away from moving belt.
- Never try to adjust or fix the belt while it is moving.
-  •Always wear athletic shoes while operating treadmill.

IMPORTANT PRECAUTIONS

▲ WARNING: To reduce the risk of serious injury, read all important precautions and instructions in this manual and all warnings on your treadmill before using your treadmill. Sears assumes no responsibility for personal injury or property damage sustained by or through the use of this product.

1. Before beginning any exercise program, consult your physician. This is especially important for persons over age 35 or persons with pre-existing health problems.
2. It is the responsibility of the owner to ensure that all users of this treadmill are adequately informed of all warnings and precautions. Use the treadmill only as described.
3. Place the treadmill on a level surface, with at least 8 ft. (2.4 m) of clearance behind it and 2 ft. (0.6 m) on each side. Do not place the treadmill on any surface that blocks air openings. To protect the floor or carpet from damage, place a mat under the treadmill.
4. Keep the treadmill indoors, away from moisture and dust. Do not put the treadmill in a garage or covered patio, or near water.
5. Do not operate the treadmill where aerosol products are used or where oxygen is being administered.
6. Keep children under age 12 and pets away from the treadmill at all times.
7. The treadmill should be used only by persons weighing 275 lbs. (125 kg) or less.
8. Never allow more than one person on the treadmill at a time.
9. Wear appropriate exercise clothes while using the treadmill. Do not wear loose clothes that could become caught in the treadmill. Athletic support clothes are recommended for both men and women. *Always wear athletic shoes; never use the treadmill with bare feet, wearing only stockings, or in sandals.*
10. When connecting the power cord (see page 14), plug the power cord into a surge suppressor (not included) and plug the surge suppressor into a grounded circuit capable of carrying 15 or more amps. No other appliance should be on the same circuit. Do not use an extension cord.
11. Use only a single-outlet surge suppressor that meets all of the specifications described on page 14. To purchase a surge suppressor, see your local Sears store or call the telephone number on the back cover of this manual and order part number 146148, or see your local electronics store.
12. Failure to use a properly functioning surge suppressor could result in damage to the control system of the treadmill. If the control system is damaged, the walking belt may change speed, accelerate, or stop unexpectedly, which may result in a fall and serious injury.
13. Keep the power cord and the surge suppressor away from heated surfaces.
14. Never move the walking belt while the power is turned off. Do not operate the treadmill if the power cord or plug is damaged, or if the treadmill is not working properly. (See TROUBLESHOOTING on page 22 if the treadmill is not working properly.)
15. Read, understand, and test the emergency stop procedure before using the treadmill (see HOW TO TURN ON THE POWER on page 16).
16. Never start the treadmill while you are standing on the walking belt. Always hold the handrails or crosswalk arms while using the treadmill.
17. The treadmill is capable of high speeds. Adjust the speed in small increments to avoid sudden jumps in speed.
18. The pulse sensor is not a medical device. Various factors, including the user's movement, may affect the accuracy of heart rate readings. The pulse sensor is intended only as an exercise aid in determining heart rate trends in general.

19. Never leave the treadmill unattended while it is running. Always remove the key, unplug the power cord, and switch the reset/off circuit breaker to the off position when the treadmill is not in use. (See the drawing on page 5 for the location of the circuit breaker.)
20. Do not attempt to raise, lower, or move the treadmill until it is properly assembled. (See ASSEMBLY on page 6, and HOW TO FOLD AND MOVE THE TREADMILL on page 20.) You must be able to safely lift 45 lbs. (20 kg) to raise, lower, or move the treadmill.
21. When folding or moving the treadmill, make sure that the frame is held securely in the storage position.
22. Never insert any object into any opening on the treadmill.
23. Inspect and properly tighten all parts of the treadmill regularly.
24. **DANGER:** Always unplug the power cord immediately after use, before cleaning the treadmill, and before performing the maintenance and adjustment procedures described in this manual. Never remove the motor hood unless instructed to do so by an authorized service representative. Servicing other than the procedures in this manual should be performed by an authorized service representative only.
25. This treadmill is intended for in-home use only. Do not use this treadmill in a commercial, rental, or institutional setting.

SAVE THESE INSTRUCTIONS

BEFORE YOU BEGIN

Thank you for selecting the new PROFORM® CROSSWALK 480 treadmill. The CROSSWALK 480 treadmill offers a selection of features designed to make your workouts at home more effective and enjoyable. And when you're not exercising, the CROSSWALK 480 treadmill can be folded up, requiring less than half the floor space of other treadmills.

For your benefit, read this manual carefully before using the treadmill. If you have questions after read-

ing this manual, please see the back cover of this manual. To help us assist you, please note the product model number and serial number before contacting us. The model number and the location of the serial number decal are shown on the front cover of this manual.

Before reading further, please review the drawing below and familiarize yourself with the labeled parts.

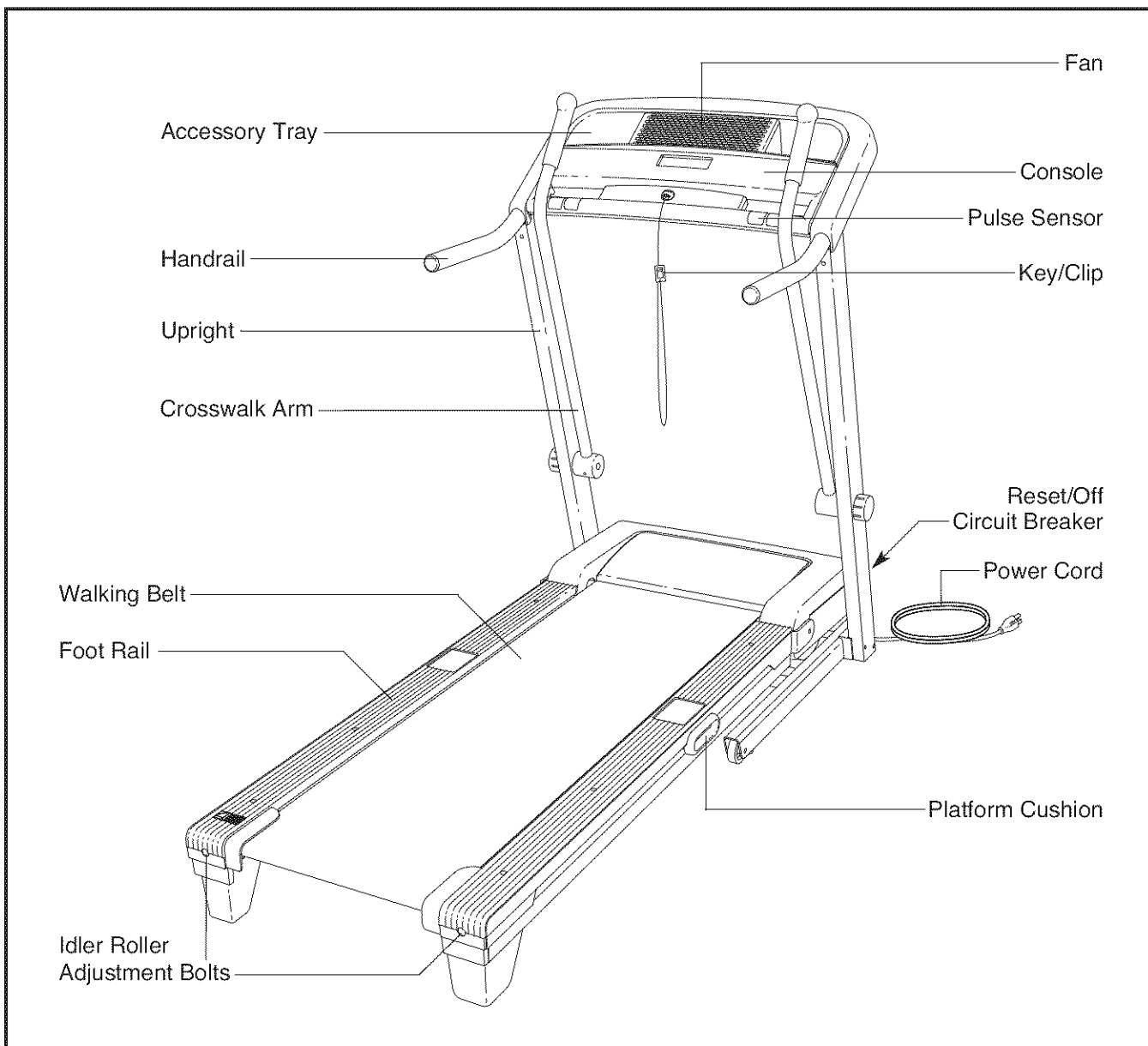

ASSEMBLY

Assembly requires two persons. Set the treadmill in a cleared area and remove all packing materials. **Do not dispose of the packing materials until assembly is completed.** Note: The underside of the treadmill walking belt is coated with high-performance lubricant. During shipping, a small amount of lubricant may be transferred to the top of the walking belt or the shipping carton. This is a normal condition and does not affect treadmill performance. If there is lubricant on top of the walking belt, simply wipe off the lubricant with a soft cloth and a mild, non-abrasive cleaner.

Assembly requires the included hex keys  and your own Phillips screwdriver , adjustable wrench , and scissors .

Use the drawings below to identify the assembly hardware. The number in parentheses below each drawing is the key number of the part, from the PART LIST near the end of this manual. The number after the parentheses is the quantity needed for assembly. **Note: If a part is not in the hardware kit, check to see if it is preattached to one of the parts to be assembled. To avoid damaging plastic parts, do not use power tools for assembly. Extra hardware may be included. If a part is missing, call 1-888-533-1333.**

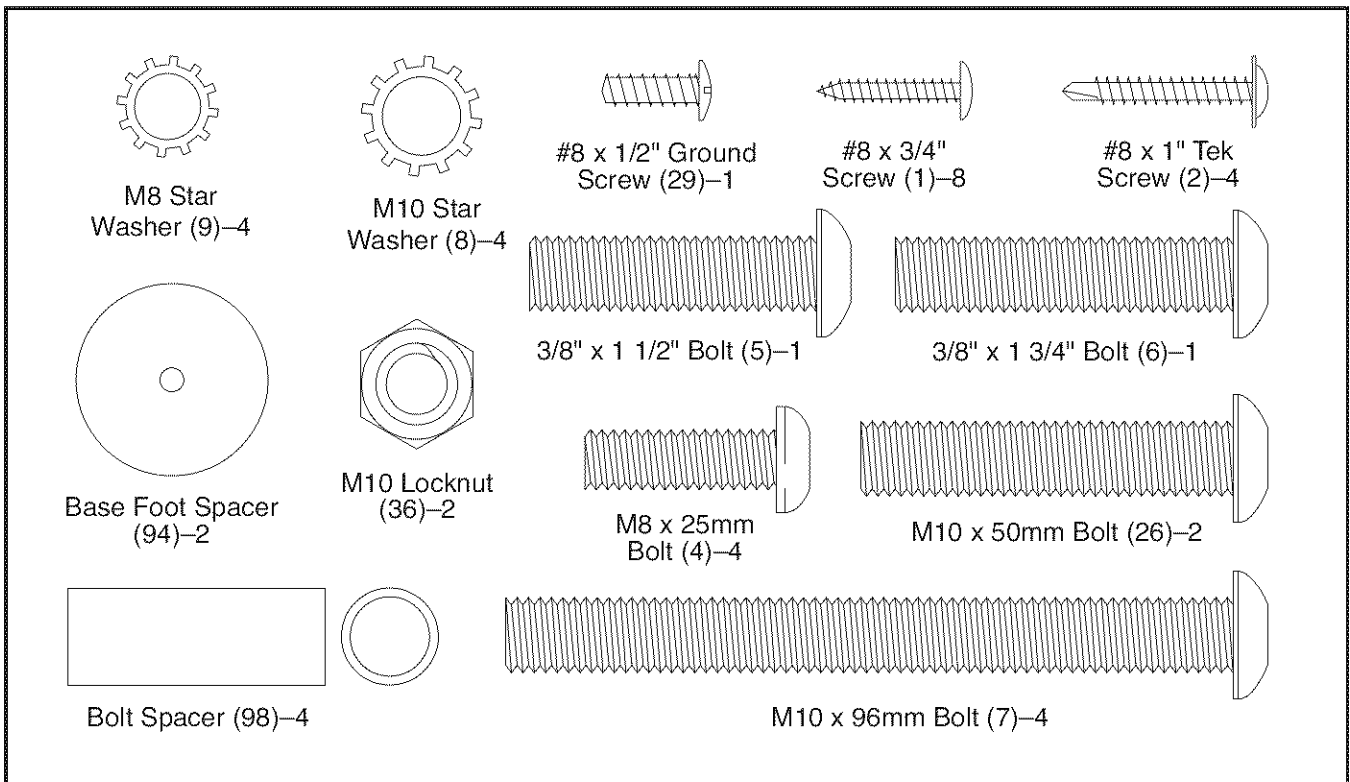

1. **Make sure that the power cord is unplugged.**

With the help of a second person, carefully tip the treadmill onto its left side. Partially fold the Frame (57) so that the treadmill is more stable; **do not fully fold the Frame yet.**

Cut the tie securing the Wire Harness (92) to the Base (99). Next, locate a tie in the indicated hole in the Base, and use the tie to pull the Wire Harness out of the hole.

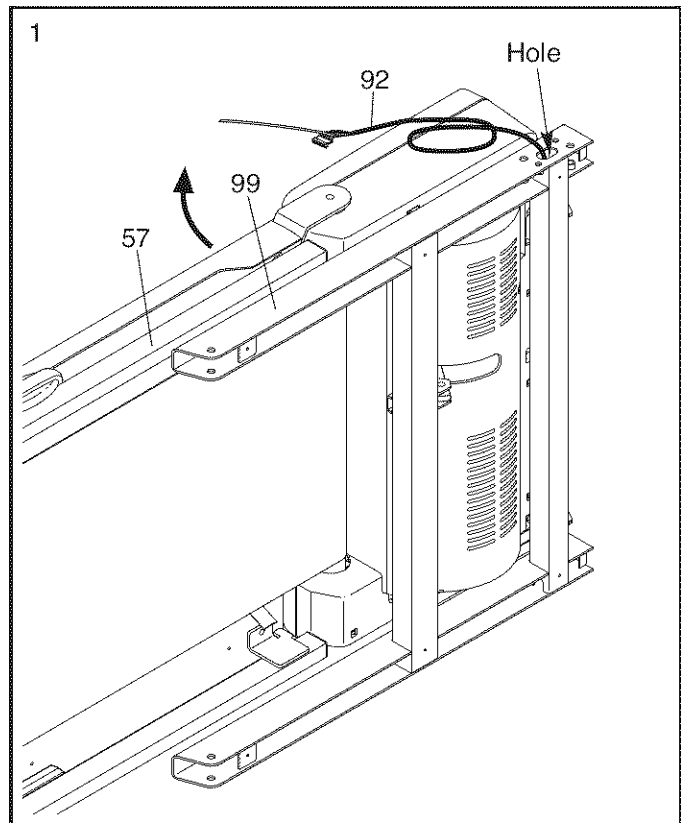

2. Attach two Base Feet (93) to the Base (99) in the locations shown with two #8 x 1" Tek Screws (2) and two Base Foot Spacers (94).

Attach the other two Base Feet (93) with only two #8 x 1" Tek Screws (2).

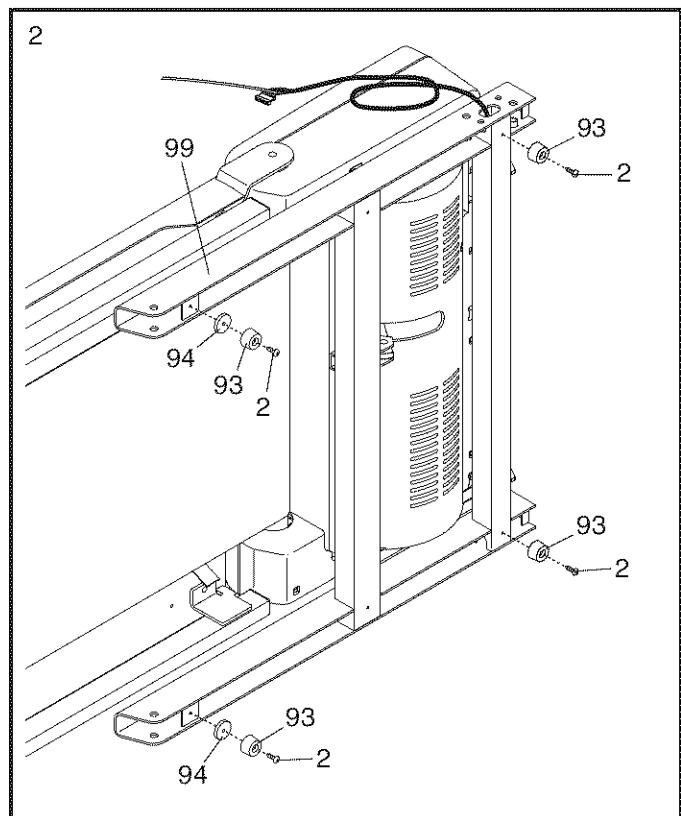

- Attach a Wheel (95) to the Base (99) with an M10 x 50mm Bolt (26) and an M10 Locknut (36). **Do not overtighten the Locknut; the Wheel must turn freely.**

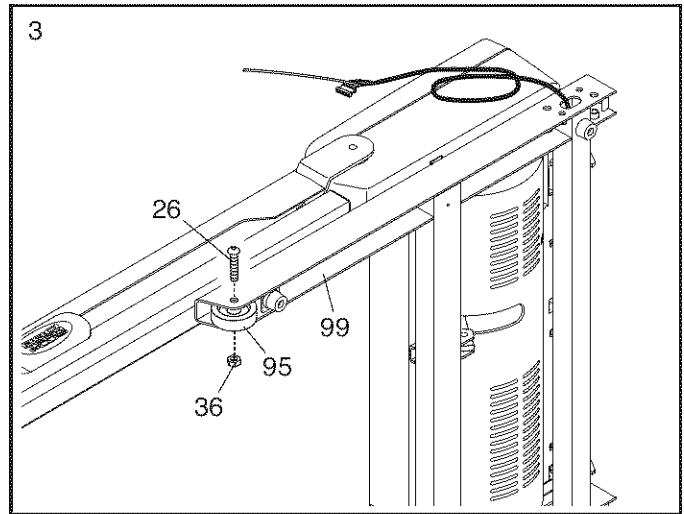

- Identify the Right Upright (80) and the Right Upright Spacer (90), which are marked with stickers.

Insert the Wire Harness (92) through the Right Upright Spacer (90) as shown. Then, set the Right Upright Spacer on the Base (99).

With the help of a second person, hold the Right Upright (80) near the Base (99). **See the inset drawing.** Tie the wire tie in the Right Upright securely around the end of the Wire Harness (92). Then, pull the other end of the wire tie until the Wire Harness is routed completely through the Right Upright.

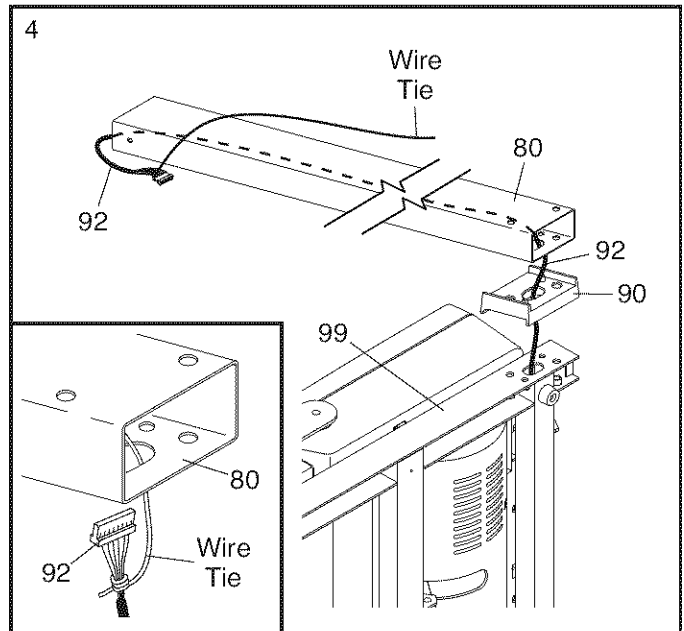

- Hold a Bolt Spacer (98) inside the lower end of the Right Upright (80). Insert an M10 x 96mm Bolt (7) with an M10 Star Washer (8) into the Right Upright and the Bolt Spacer. **Repeat this step with a second Bolt Spacer (98), M10 x 96mm Bolt (7), and M10 Star Washer (8).**

Hold the Right Upright Spacer (90) and the Right Upright (80) against the Base (99). **Be careful not to pinch the Wire Harness (92).** Tighten the M10 x 96mm Bolts (7) until the heads of the Bolts touch the Upright; **do not fully tighten the Bolts yet.**

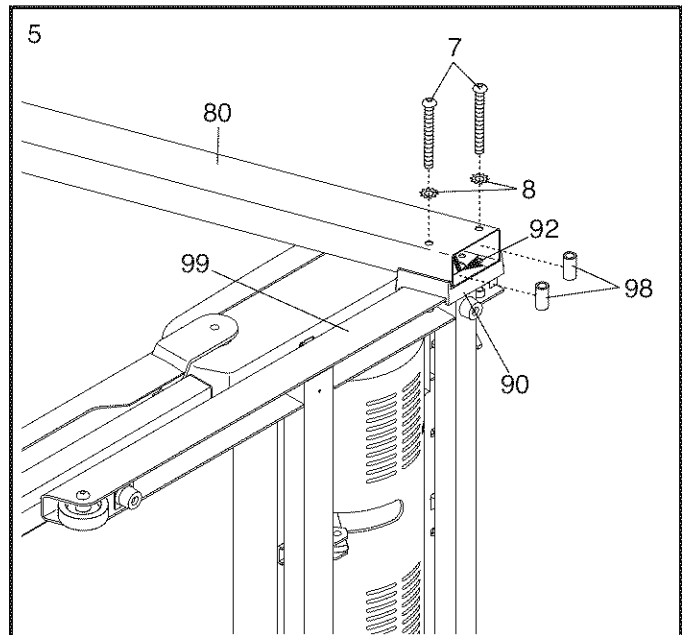

6. Press a Base Cap (91) into the Base (99).

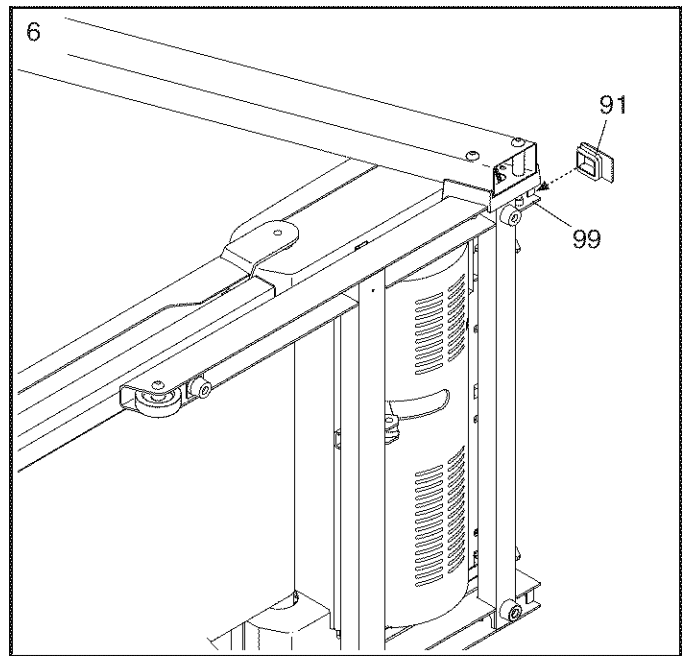

7. With the help of a second person, carefully tip the treadmill onto its right side. Partially fold the Frame (57) so that the treadmill is more stable; **do not fully fold the Frame yet.**

Attach a Wheel (95) to the Base (99) with an M10 x 50mm Bolt (26) and an M10 Locknut (36). **Do not overtighten the Locknut; the Wheel must turn freely.**

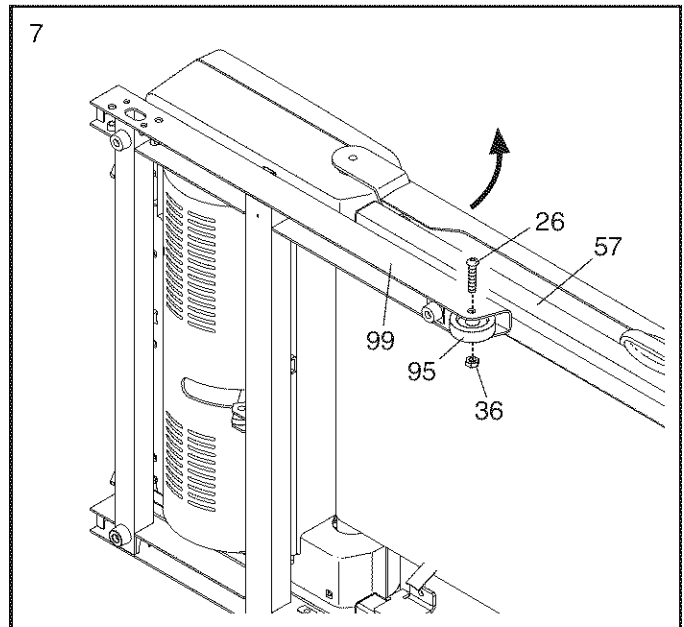

8. With the help of a second person, hold a Bolt Spacer (98) inside the lower end of the Left Upright (79). Insert an M10 x 96mm Bolt (7) with an M10 Star Washer (8) into the Left Upright and the Bolt Spacer. **Repeat this step with a second Bolt Spacer (98), M10 x 96mm Bolt (7), and M10 Star Washer (8).**

Orient the Left Upright (79) and the Left Upright Spacer (89) as shown. Hold the Left Upright Spacer and the Left Upright against the Base (99). Tighten the M10 x 96mm Bolts (7) until the heads of the Bolts touch the Upright; **do not fully tighten the Bolts yet.**

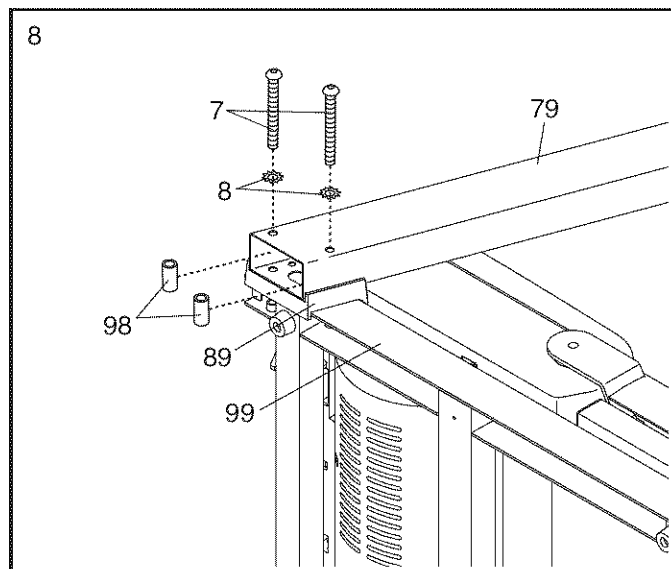

9. Press a Base Cap (91) into the Base (99).

With the help of a second person, tip the treadmill so that the Base (99) is flat on the floor.

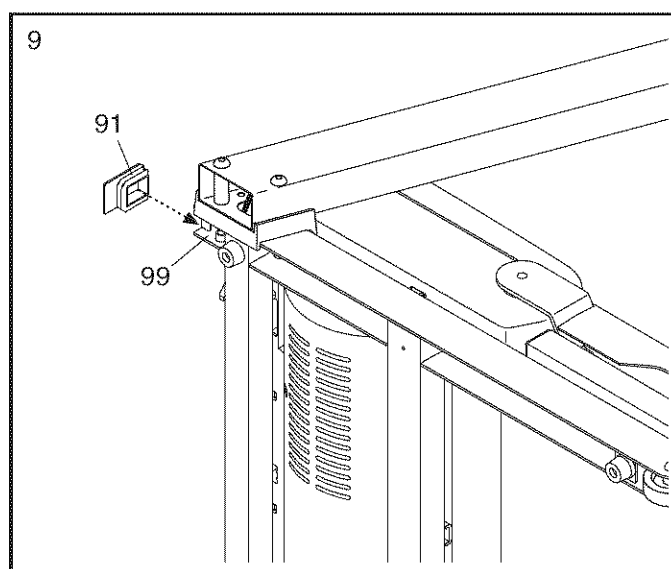

10. Set the console assembly face down on a soft surface to avoid scratching the console assembly.

Identify the Right Handrail (100) which is marked with a sticker. Hold the Right Handrail near the console assembly. Attach the console ground wire to the Right Handrail with a #8 x 1/2" Ground Screw (29).

Next, insert the console wire into the large hole in the Right Handrail (100) and out of the top as shown. Attach the Right Handrail with three #8 x 3/4" Screws (1). **Make sure that no wires are pinched. Start all three Screws before tightening any of them; do not over-tighten the Screws.**

Remove the ties from the M8 Cage Nuts (39). If necessary, press the Cage Nuts back into place.

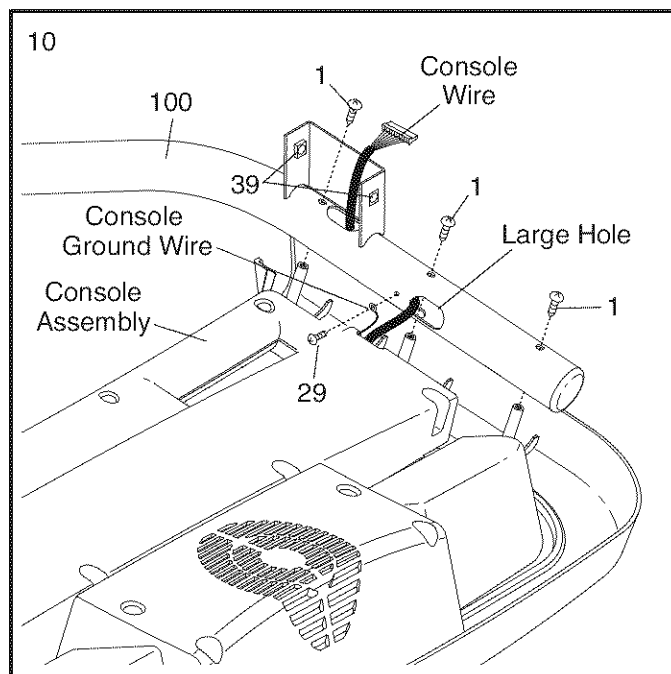

11. Attach the Left Handrail (21) to the console assembly with three #8 x 3/4" Screws (1).

Remove the ties from the M8 Cage Nuts (39). If necessary, press the Cage Nuts back into place.

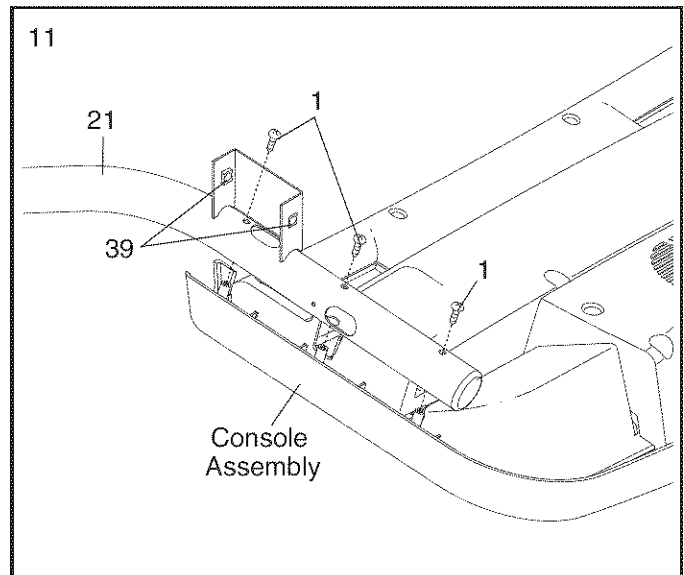

12. Have a second person hold the console assembly near the Right Upright (80).

Connect the Wire Harness (92) to the console wire. **See the inset drawing. The connectors should slide together easily and snap into place.** If they do not, turn one connector and try again. **IF THE CONNECTORS ARE NOT CONNECTED PROPERLY, THE CONSOLE MAY BE DAMAGED WHEN THE POWER IS TURNED ON.** Remove the wire tie from the Wire Harness. Then, insert the connectors into the Right Upright (80).

Set the console assembly on the Right Upright (80) and the Left Upright (not shown). **Make sure that no wires are pinched.**

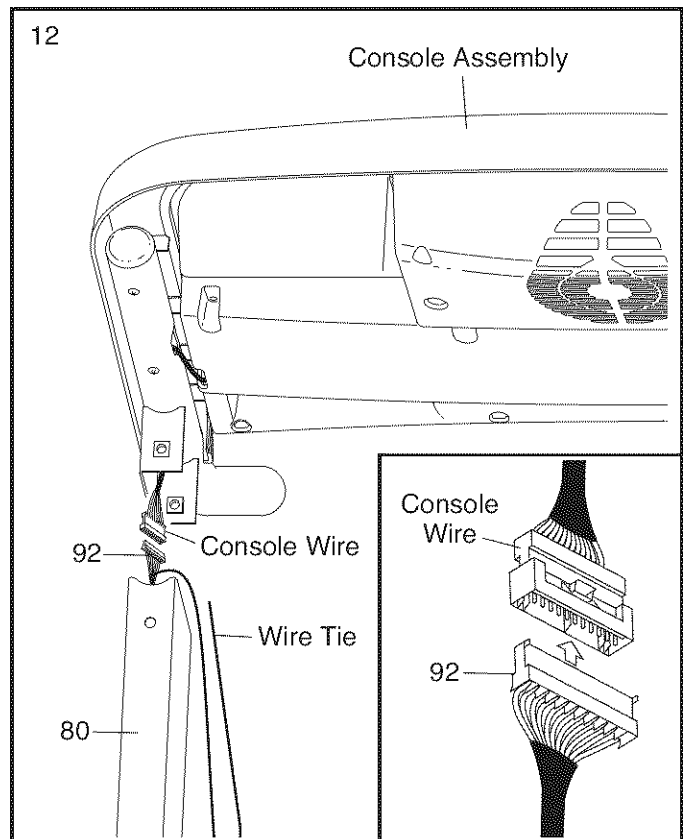

13. Finger tighten two M8 x 25mm Bolts (4) with two M8 Star Washers (9) into the Left Upright (79) and the Left Handrail (21); **do not fully tighten the Bolts yet.**

Next, finger tighten two M8 x 25mm Bolts (4) with two M8 Star Washers (9) into the Right Upright (80) and the Right Handrail (100). **Then, tighten all four Bolts.**

See steps 5 and 8. Tighten the M10 x 96mm Bolts (7).

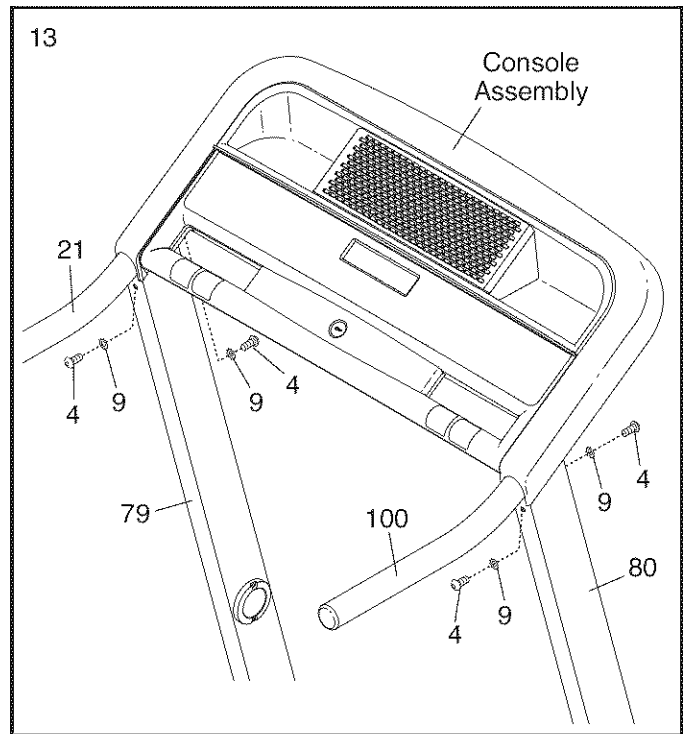

14. Remove the Resistance Knob (88) from a resistance mechanism. **Make sure that the 3/8" x 4 3/4" Bolt (3) stays inside of the resistance mechanism and that the resistance mechanism does not come apart.** Note: See the lower drawing to reassemble the resistance mechanism if necessary.

Insert the Resistance Cone (85) into the Upright Insert (84) in the Left Upright (79), with the two large holes on top as shown. Then, attach the Resistance Knob (88) onto the 3/8" x 4 3/4" Bolt (3). **Do not fully tighten the Resistance Knob.**

Attach the other resistance mechanism to the Right Upright (80) as described above.

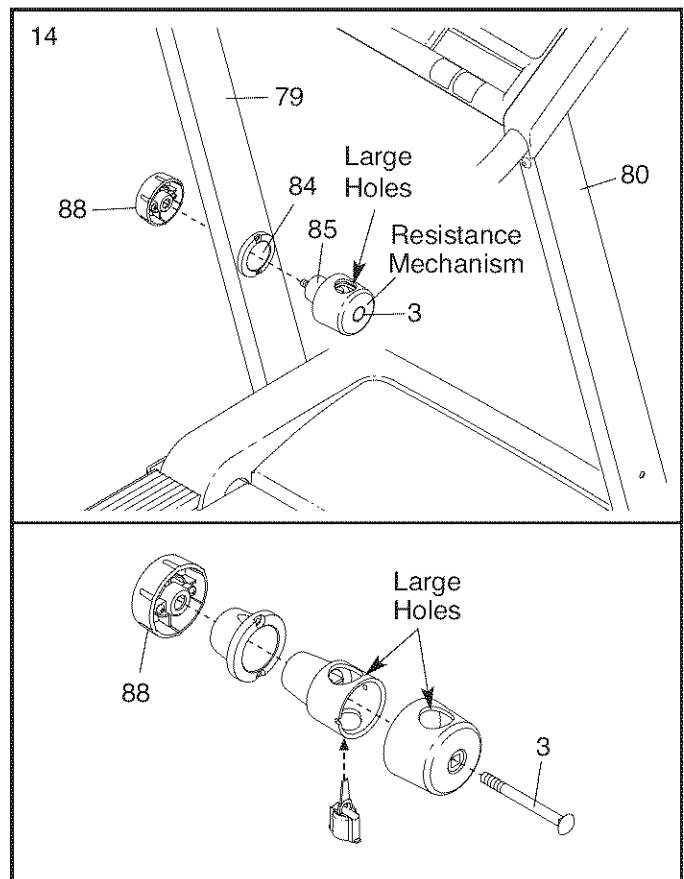

15. Insert the end of a Crosswalk Arm (82) into the hole in the top of a resistance mechanism. **Make sure that the bend in the Crosswalk Arm is positioned as shown.**

Tighten the #8 x 3/4" Screw (1) into the resistance mechanism and Crosswalk Arm (82) from the direction shown. Press a Small Cap (13) into the hole for the Screw.

Attach the other Crosswalk Arm (82) as described above.

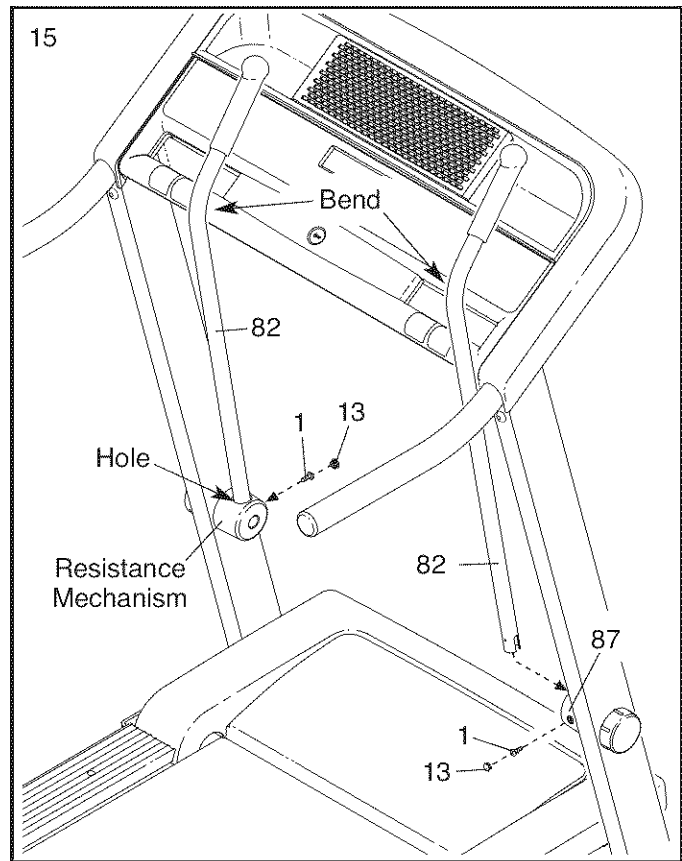

16. Raise the Frame (57) to the position shown. **Have a second person hold the Frame until this step is completed.**

Orient the Storage Latch (54) so that the large barrel and the Latch Knob (55) are in the positions shown.

Attach the upper end of the Storage Latch (54) to the Frame (57) with a 3/8" x 1 1/2" Bolt (5).

Attach the lower end of the Storage Latch (54) to the Base (99) with a 3/8" x 1 3/4" Bolt (6). Note: It may be necessary to move the Frame (57) back and forth to align the Storage Latch with the Base.

Lower the Frame (57) (see HOW TO LOWER THE TREADMILL FOR USE on page 21).

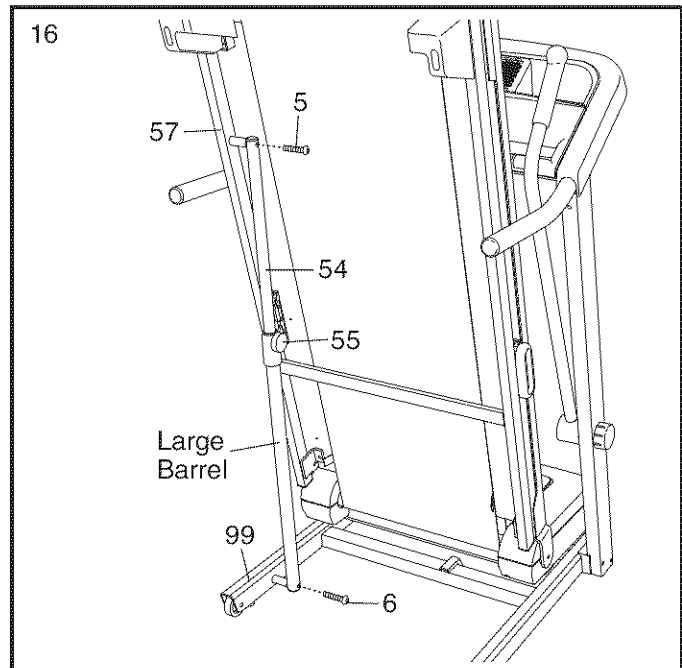

17. **Make sure that all parts are properly tightened before you use the treadmill.** If there are sheets of clear plastic on the treadmill decals, remove the plastic. To protect the floor or carpet, place a mat under the treadmill. Keep the included hex keys in a secure place; the large hex key is used to adjust the walking belt (see pages 23 and 24).

OPERATION AND ADJUSTMENT

THE PRE-LUBRICATED WALKING BELT

Your treadmill features a walking belt coated with high-performance lubricant. **IMPORTANT: Never apply silicone spray or other substances to the walking belt or the walking platform. Such substances will deteriorate the walking belt and cause excessive wear.**

HOW TO PLUG IN THE POWER CORD

⚠ DANGER: Improper connection of the equipment-grounding conductor can result in an increased risk of electric shock. Check with a qualified electrician or serviceman if you are in doubt as to whether the product is properly grounded. Do not modify the plug provided with the product—if it will not fit the outlet, have a proper outlet installed by a qualified electrician.

Your treadmill, like any other type of sophisticated electronic equipment, can be seriously damaged by sudden voltage changes in your home's power. Voltage surges, spikes, and noise interference can result from weather conditions or from other appliances being turned on or off. **To decrease the possibility of your treadmill being damaged, always use a surge suppressor with your treadmill (see drawing 1 at the right). To purchase a surge suppressor, see your local Sears store or call the telephone number on the back cover of this manual and order part number 146148, or see your local electronics store.**

Use only a single-outlet surge suppressor that is UL 1449 listed as a transient voltage surge suppressor (TVSS). The surge suppressor must have a UL suppressed voltage rating of 400 volts or less and a minimum surge dissipation of 450 joules. The surge suppressor must be electrically rated for 120 volts AC and 15 amps. There must be a monitoring light on the surge suppressor to indicate whether it is functioning properly. Failure to use a properly functioning surge suppressor could result in damage to the control system of the treadmill. If the control system is damaged, the walking belt may change speed, accelerate, or stop unexpectedly, which may result in a fall and serious injury.

This product must be grounded. If it should malfunction or break down, grounding provides a path of least resistance for electric current to reduce the risk of elec-

tric shock. This product is equipped with a cord having an equipment-grounding conductor and a grounding plug. **Plug the power cord into a surge suppressor, and plug the surge suppressor into an appropriate outlet that is properly installed and grounded in accordance with all local codes and ordinances. Important: The treadmill is not compatible with GFCI-equipped outlets.**

This product is for use on a nominal 120-volt circuit, and has a grounding plug that looks like the plug illustrated in drawing 1 below. A temporary adapter that looks like the adapter illustrated in drawing 2 may be used to connect the surge suppressor to a 2-pole receptacle as shown in drawing 2 if a properly grounded outlet is not available.

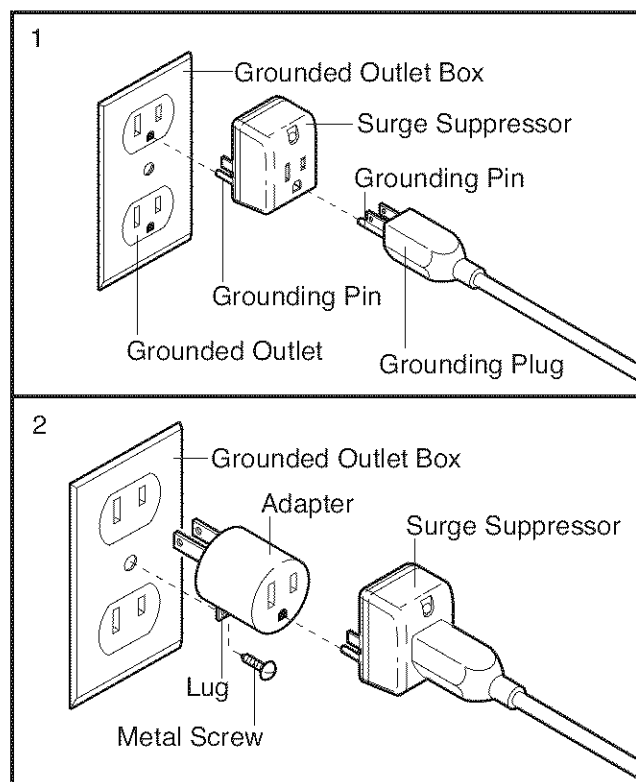

The temporary adapter should be used only until a properly grounded outlet (drawing 1) can be installed by a qualified electrician.

The green-colored rigid ear, lug, or the like extending from the adapter must be connected to a permanent ground such as a properly grounded outlet box cover. Whenever the adapter is used it must be held in place by a metal screw. **Some 2-pole receptacle outlet box covers are not grounded. Contact a qualified electrician to determine if the outlet box cover is grounded before using an adapter.**

CONSOLE DIAGRAM

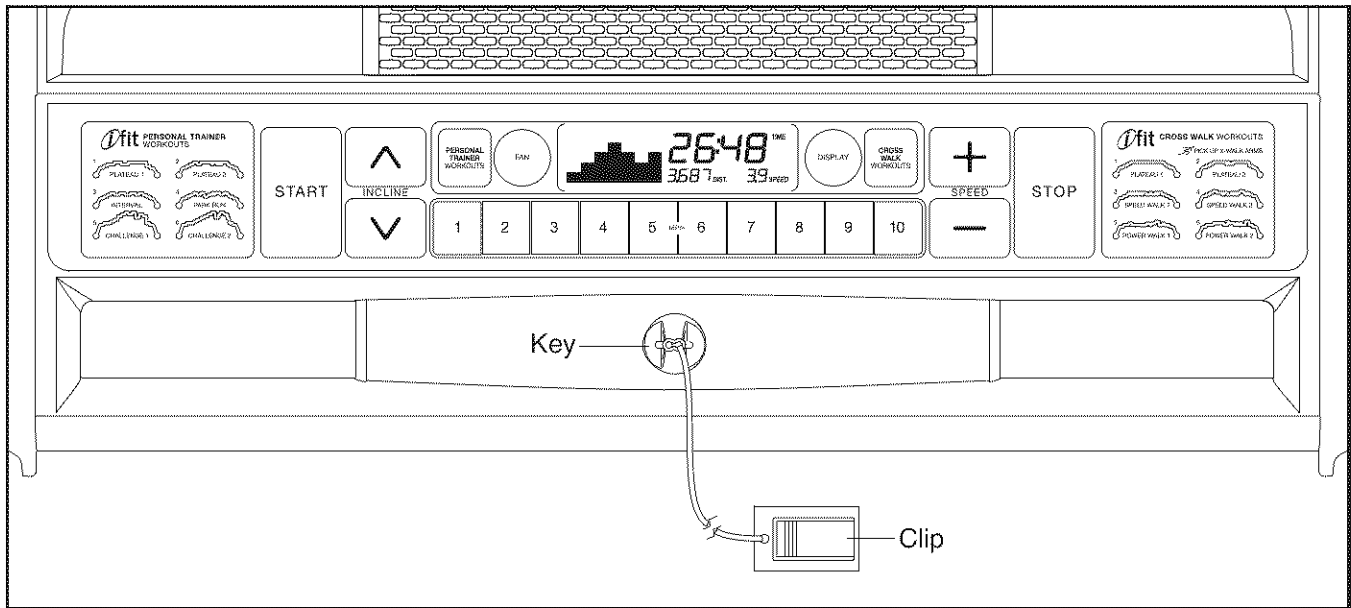

FEATURES OF THE CONSOLE

The treadmill console offers a selection of features designed to make your workouts more effective and enjoyable. When you select the manual mode of the console, you can change the speed and incline of the treadmill with the touch of a button. As you exercise, the console will display continuous exercise feedback. You can even measure your heart rate using the built-in handgrip pulse sensor.

The console also features six preset iFit personal trainer workouts. Each workout controls the speed and incline of the treadmill as it guides you through an effective workout. In addition, the console offers six preset iFit crosswalk workouts that automatically control the speed and incline of the treadmill and prompt you to use the crosswalk arms for a total body workout.

To turn on the power, see page 16. To use the manual mode, see page 16. To use a preset workout, see page 18. To use the information mode, see page 19.

IMPORTANT: If there is a sheet of clear plastic on the face of the console, remove the plastic. To prevent damage to the walking platform, wear clean athletic shoes while using the treadmill. The first time the treadmill is used, observe the alignment of the walking belt, and center the walking belt if necessary (see page 24).

Note: The console can display speed and distance in either miles or kilometers. To find which unit of measurement is selected, see THE INFORMATION MODE on page 19. For simplicity, all instructions in this manual refer to miles.

HOW TO TURN ON THE POWER

IMPORTANT: If the treadmill has been exposed to cold temperatures, allow it to warm to room temperature before turning on the power. If you do not do this, you may damage the console displays or other electrical components.

Plug in the power cord (see page 14). Next, locate the reset/off circuit breaker on the treadmill frame near the power cord. Switch the circuit breaker to the reset position.

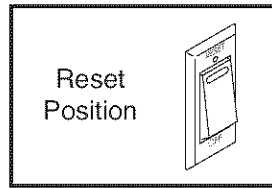

IMPORTANT: The console features a display demo mode, designed to be used if the treadmill is displayed in a store. If the displays light as soon as you plug in the power cord and switch the reset/off circuit breaker to the reset position, the demo mode is turned on. To turn off the demo mode, hold down the Stop button for a few seconds. If the displays remain lit, see THE INFORMATION MODE on page 19 to turn off the demo mode.

Next, stand on the foot rails of the treadmill. Find the clip attached to the key (see the drawing on page 15) and slide the clip onto the waistband of your clothes. Then, insert the key into the console. After a moment, the displays will light. **IMPORTANT:** In an emergency situation, the key can be pulled from the console, causing the walking belt to slow to a stop. Test the clip by carefully taking a few steps backward; if the key is not pulled from the console, adjust the position of the clip.

HOW TO USE THE MANUAL MODE

1. Insert the key into the console.

See HOW TO TURN ON THE POWER above.

2. Select the manual mode.

When the key is inserted, the manual mode will be selected. If you have selected a workout, press either of the Workout buttons repeatedly until only zeros appear in the displays.



3. Start the walking belt.

To start the walking belt, press the Start button, the Speed increase button, or one of the ten numbered speed buttons.

If you press the Start button or the Speed increase button, the walking belt will begin to move at 1 mph. As you exercise, change the speed of the walking belt as desired by pressing the Speed increase and decrease buttons. Each time you press a button, the speed setting will change by 0.1 mph; if you hold down a button, the speed setting will change in increments of 0.5 mph.

If you press one of the ten numbered speed buttons, the walking belt will gradually change speed until it reaches the selected speed setting.

To stop the walking belt, press the Stop button. The time will begin to flash in the display. To restart the walking belt, press the Start button, the Speed increase button, or one of the ten numbered speed buttons.

4. Change the incline of the treadmill as desired.

To change the incline of the treadmill, press the Incline increase and decrease buttons. Each time you press a button, the incline setting will change by 0.5 percent; if you hold down a button, the incline setting will change quickly.

5. Follow your progress with the displays.

When you select the manual mode, a track representing 1/4 mile will appear in the matrix.

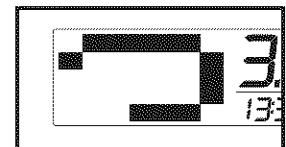

As you walk or run on the treadmill, the indicators around the track will appear in succession until the entire track appears. The track will then disappear and the indicators will again begin to appear in succession.

The lower left display can show the elapsed time and the distance that you have walked or run during your workout. Each time you change the incline, the display will show the incline setting for a few seconds. Note: When a workout is selected, the display will show the time remaining in the workout instead of the elapsed time.



The lower right display can show the speed of the walking belt and the approximate number of calories that you have burned during your workout. The display will also show your heart rate when you use the handgrip pulse sensor (see step 6 below).

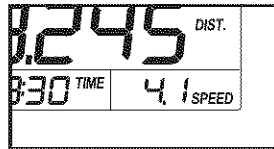

The upper display can show the elapsed time, the distance that you have walked or run, the approximate number of calories you have burned, or the speed of the walking belt. Press the Display button repeatedly until the upper display shows the information that you are most interested in viewing. Note: While information is shown in the upper display, the same information will not be shown in the lower left or lower right display.

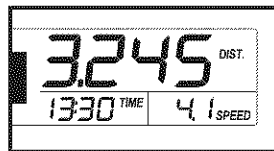

To reset the displays, press the Stop button, remove the key, and then reinsert the key.

6. Measure your heart rate if desired.

Before using the handgrip pulse sensor, remove the sheets of clear plastic from the metal contacts. In addition, make sure that your hands are clean.

To measure your heart rate, **stand on the foot rails** and place your hands on the metal contacts—**avoid moving your hands.**

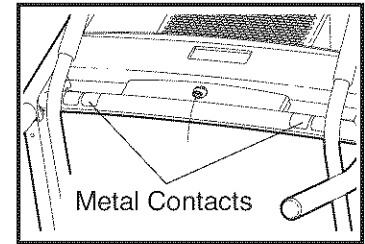

When your pulse is detected, the heart symbol in the display will begin to flash, one or two dashes will appear, and then your heart rate will be shown. **For the most accurate heart rate reading, continue to hold the contacts for about 15 seconds.**

7. Turn on the fan if desired.

The fan features low and high speed settings. Press the Fan button repeatedly to select a fan speed or to turn off the fan. Note: If the fan is on when the walking belt is stopped, the fan will turn off automatically after a few minutes.

8. When you are finished exercising, remove the key from the console.

Step onto the foot rails, press the Stop button, and **adjust the incline of the treadmill to the lowest setting. The incline must be at the lowest setting when you fold the treadmill to the storage position, or you may damage the treadmill.** Next, remove the key from the console and put it in a secure place.

When you are finished using the treadmill, switch the reset/off circuit breaker to the "off" position and unplug the power cord. **IMPORTANT: If you do not do this, the treadmill's electrical components may wear prematurely.**

HOW TO USE A PRESET WORKOUT

1. Insert the key into the console.

See HOW TO TURN ON THE POWER on page 16.

2. Select an iFit personal trainer workout or an iFit cross walk workout.

To select a preset workout, press the Personal Trainer Workouts button or the Cross walk

Workouts button repeatedly until "P 1," "P 2," "P

3," "P 4," "P 5," or "P 6" appears in the display.

When you select a workout, the maximum speed and incline settings of the workout will flash in the displays for a few seconds; then the display will show how long the workout will last. A profile of the speed settings of the workout will scroll across the matrix.

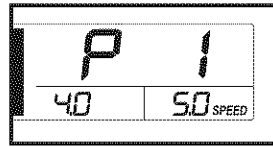

3. Press the Start button or the Speed increase button to start the workout.

A moment after you press the button, the treadmill will automatically adjust to the first speed and incline settings for the workout. Hold the handrails and begin walking.

Each workout is divided into 30 one-minute segments. One speed setting and one incline setting are programmed for each segment. Note: The same speed and incline settings may be programmed for consecutive segments.

During the workout, the profile will show your progress. The flashing segment of the profile represents the current segment of the workout.

The height of the flashing segment indicates the speed setting for the current segment. At the end of each segment, a series of tones will sound and the next segment of the profile will begin to flash. If a different speed or incline setting is programmed for the next segment, the speed or incline setting will flash in the display to alert you.

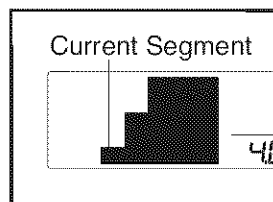

If you have selected a cross walk workout, you will be prompted to use the crosswalk arms. When the cross walk indicator on the console lights up, move the crosswalk arms forward and backward as you walk or run on the treadmill. This action exercises your arms, shoulders, and back for a total body workout.

The workout will continue in this way until the last segment of the profile flashes in the display and the last segment ends. The walking belt will then slow to a stop.

If the speed or incline setting for the current segment is too high or too low, you can manually override the setting by pressing the Speed and Incline buttons; **however, when the current segment of the workout ends, the treadmill will automatically adjust to the speed and incline settings for the next segment.**

To stop the workout at any time, press the Stop button. To restart the workout, press the Start button or the Speed increase button. The walking belt will begin to move at 1 mph. When the next segment of the workout begins, the treadmill will automatically adjust to the speed and incline settings for that segment.

4. Change the incline of the treadmill as desired.

See step 4 on page 16.

5. Follow your progress with the displays.

See step 5 on pages 16 and 17.

6. Measure your heart rate if desired.

See step 6 on page 17.

7. Turn on the fan if desired.

See step 7 on page 17.

8. When you are finished exercising, remove the key from the console.

See step 8 on page 17.

THE INFORMATION MODE

The console features an information mode that keeps track of treadmill usage information and allows you to select a unit of measurement for the console. You can also turn on and turn off the display demo mode.

To select the information mode, insert the key into the console while holding down the Stop button. Then, release the Stop button. When the information mode is selected, the following information will be shown:

The upper display will show the total number of hours that the treadmill has been used.



The lower left display will show the total number of miles or kilometers that the walking belt has moved.

An "E" for English miles or an "M" for metric kilometers will appear in the lower right display. Press the Speed increase button to change the unit of measurement, if desired.

The console features a display demo mode, designed to be used if the treadmill is displayed in a store. While the demo mode is turned on, the console will function normally when you plug in the power cord, switch the reset/off circuit breaker to the reset position, and insert the key into the console. However, when you remove the key, the displays will remain lit, although the buttons will not function. If the demo mode is turned on, a "d" will appear in the lower right display while the information mode is selected. To turn on or turn off the demo mode, press the Speed decrease button.

To exit the information mode, remove the key from the console.

HOW TO USE THE CROSSWALK ARMS

As you walk on the treadmill, you can hold the handrails or use the crosswalk arms. To exercise your arms, shoulders, and back for a total body workout, move the crosswalk arms forward and backward as you walk on the treadmill.

To vary the intensity of your upper body exercise, the resistance of the crosswalk arms can be adjusted. To increase the resistance, turn the resistance knobs clockwise; to decrease the resistance, turn the knobs counterclockwise.

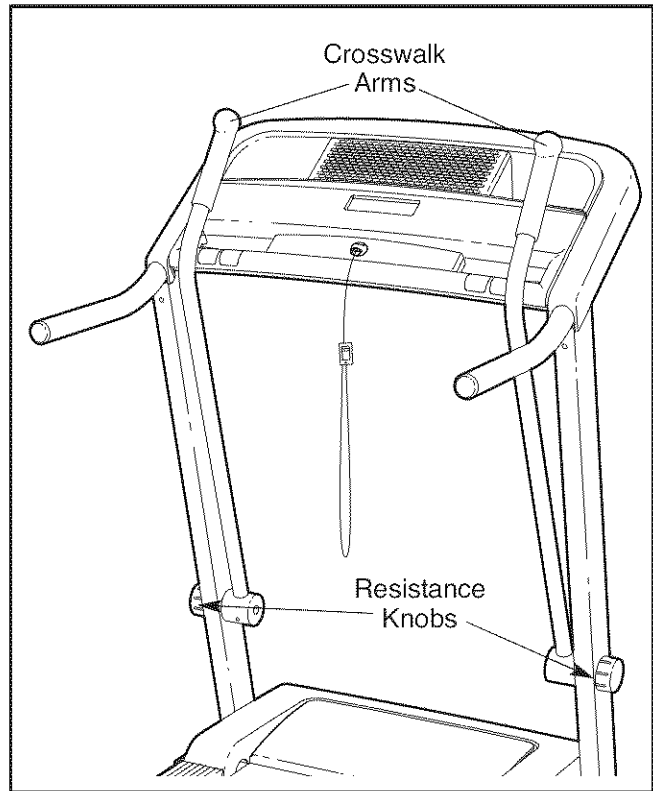

HOW TO FOLD AND MOVE THE TREADMILL

HOW TO FOLD THE TREADMILL FOR STORAGE

Before folding the treadmill, adjust the incline to the lowest position. If you do not do this, you may damage the treadmill when you fold it. Remove the key and unplug the power cord. **CAUTION:** You must be able to safely lift 45 lbs. (20 kg) to raise, lower, or move the treadmill.

1. Hold the metal frame firmly in the location shown by the arrow at the right. **CAUTION:** To decrease the possibility of injury, do not lift the frame by the plastic foot rails. Make sure to bend your legs and keep your back straight as you raise the frame. Raise the frame about halfway to the vertical position.
2. Raise the frame until the latch knob locks into the storage position. **Make sure that the latch knob is locked in the storage position.**

To protect the floor or carpet from damage, place a mat under the treadmill. Keep the treadmill out of direct sunlight. Do not leave the treadmill in the storage position in temperatures above 85° F (30° C).

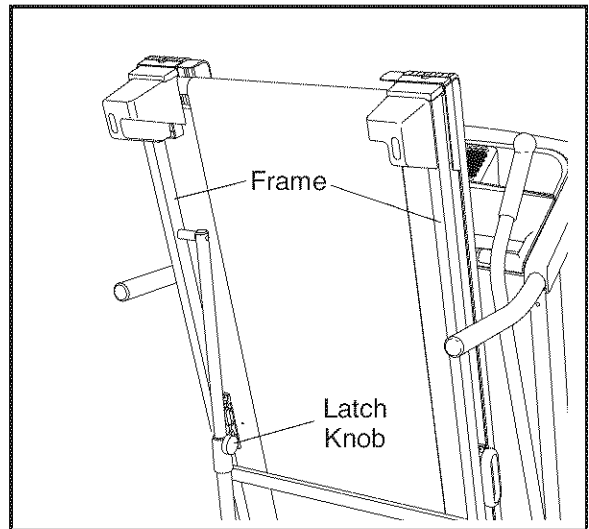
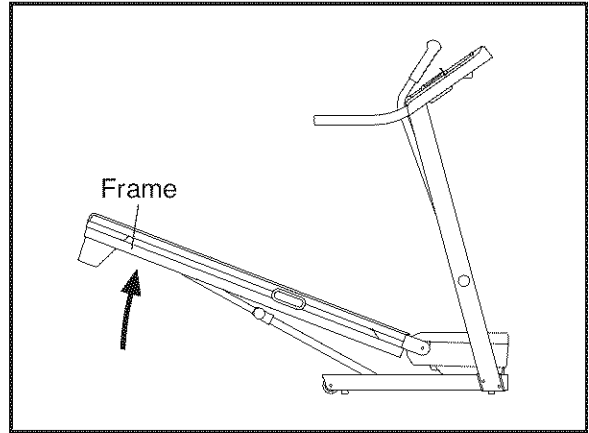

HOW TO MOVE THE TREADMILL

Before moving the treadmill, convert it to the storage position as described above. **Make sure that the latch knob is locked in the storage position.**

1. Hold a handrail and the frame, and place one foot against one of the wheels.
2. Tilt the treadmill back until it rolls freely on the wheels. Carefully move the treadmill to the desired location. **Never move the treadmill without tipping it back. To reduce the risk of injury, use extreme caution while moving the treadmill. Do not attempt to move the treadmill over an uneven surface.**
3. Place one foot against a wheel, and carefully lower the treadmill until it is resting in the storage position.

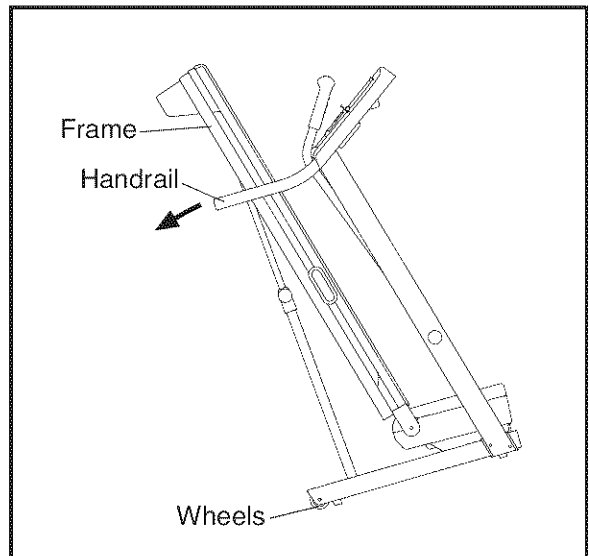

HOW TO LOWER THE TREADMILL FOR USE

1. Hold the upper end of the treadmill with your left hand. Pull the latch knob to the right and hold it. It may be necessary to push the frame forward as you pull the knob to the right. Pivot the frame downward and release the latch knob.

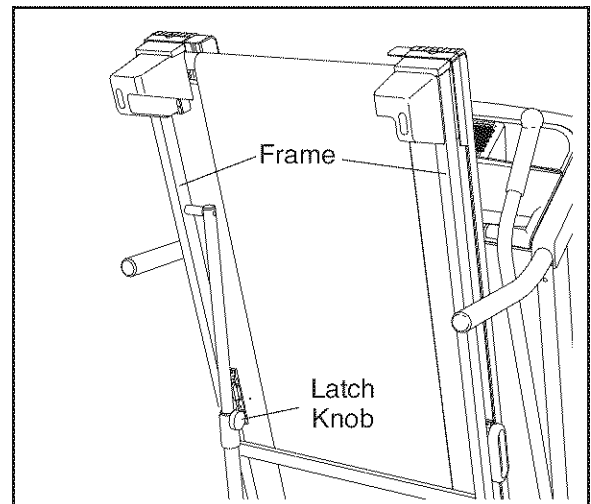

2. Hold the metal frame firmly with both hands and lower it to the floor. **CAUTION: Do not grip only the plastic foot rails or drop the frame to the floor. Bend your legs and keep your back straight.**

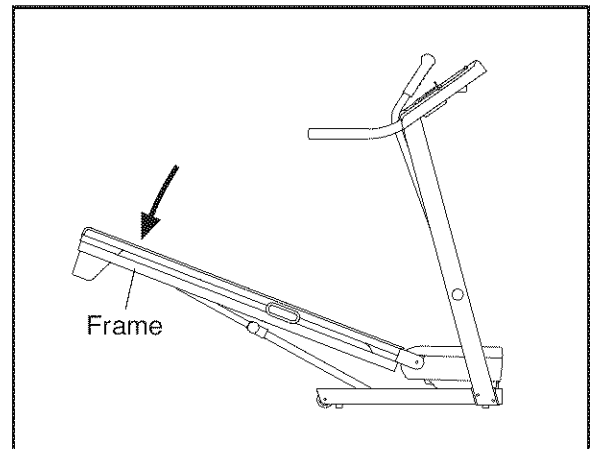

TROUBLESHOOTING

Most treadmill problems can be solved by following the steps below. Find the symptom that applies, and follow the steps listed. If further assistance is needed, please see the back cover of this manual.

PROBLEM: The power does not turn on

SOLUTION: a. Make sure that the power cord is plugged into a surge suppressor, and that the surge suppressor is plugged into a properly grounded outlet (see page 14). Use only a single-outlet surge suppressor that meets all of the specifications described on page 14. **IMPORTANT: The treadmill is not compatible with GFCI-equipped outlets.**

b. After the power cord has been plugged in, make sure that the key is inserted into the console.

c. Check the reset/off circuit breaker located on the treadmill frame near the power cord. If the switch protrudes as shown, the circuit breaker has tripped. To reset the circuit breaker, wait for five minutes and then press the switch back in.

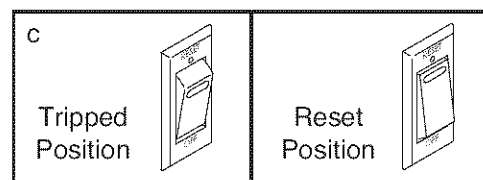

PROBLEM: The power turns off during use

SOLUTION: a. Check the reset/off circuit breaker (see the drawing above). If the circuit breaker has tripped, wait for five minutes and then press the switch back in.

b. Make sure that the power cord is plugged in. If the power cord is plugged in, unplug it, wait for five minutes, and then plug it back in.

c. Remove the key from the console. Reinsert the key into the console.

d. If the treadmill still will not run, please see the back cover of this manual.

PROBLEM: The console displays remain lit when you remove the key from the console

SOLUTION: a. The console features a display demo mode, designed to be used if the treadmill is displayed in a store. If the displays remain lit when you remove the key, the demo mode is turned on. To turn off the demo mode, hold down the Stop button for a few seconds. If the displays are still lit, see THE INFORMATION MODE on page 19 to turn off the demo mode.

PROBLEM: The displays of the console do not function properly

SOLUTION: a. Adjust the incline level of the treadmill to 5 percent. Remove the key from the console and **UNPLUG THE POWER CORD**. With the help of a second person, carefully tip down the Uprights (79, 80). There may be two Screws (A) in the bottom of the Belly Pan (78). If there are, remove them. Note: A Phillips screwdriver with a shaft at least 5 in. (13 cm) long is required. Then, raise the Uprights.

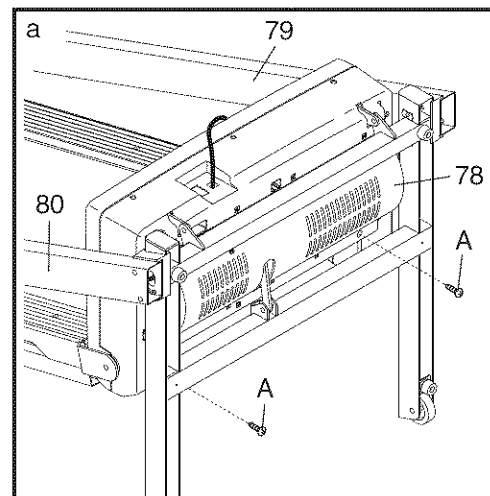

Remove the three #8 x 3/4" Screws (1) and carefully pivot the Motor Hood (63) off.

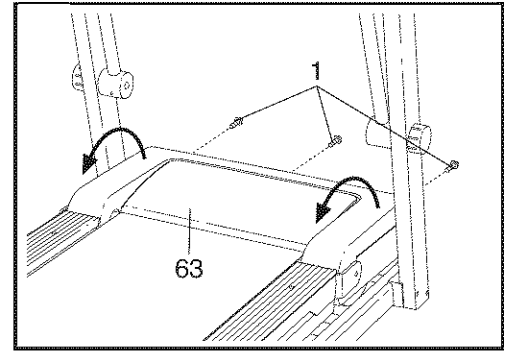

Locate the Reed Switch (69) and the Magnet (48) on the left side of the Pulley (52). Turn the Pulley until the Magnet is aligned with the Reed Switch. **Make sure that the gap between the Magnet and the Reed Switch is about 1/8 in. (3 mm).** If necessary, loosen the #8 x 3/4" Screw (1), move the Reed Switch slightly, and then retighten the Screw. Reattach the Motor Hood (not shown) with the three #8 x 3/4" Screws (not shown) and the two Screws (not shown) if necessary. Run the treadmill for a few minutes to check for a correct speed reading.

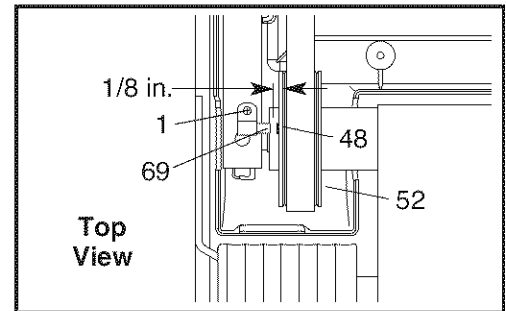

PROBLEM: The incline of the treadmill does not change correctly

SOLUTION: a. With the key in the console, press one of the Incline buttons. **While the incline is changing, remove the key.** After a few seconds, re-insert the key. The treadmill will automatically rise to the maximum incline level and then return to the minimum level. This will recalibrate the incline system.

PROBLEM: The walking belt slows when walked on

SOLUTION: a. Use only a single-outlet surge suppressor that meets all of the specifications described on page 14.

b. If the walking belt is overtightened, treadmill performance may decrease and the walking belt may become damaged. Remove the key and **UNPLUG THE POWER CORD.** Using the hex key, turn both idler roller bolts counterclockwise, 1/4 of a turn. When the walking belt is properly tightened, you should be able to lift each edge of the walking belt 2 to 3 in. (5 to 7 cm) off the walking platform. Be careful to keep the walking belt centered. Then, plug in the power cord, insert the key, and run the treadmill for a few minutes. Repeat until the walking belt is properly tightened.

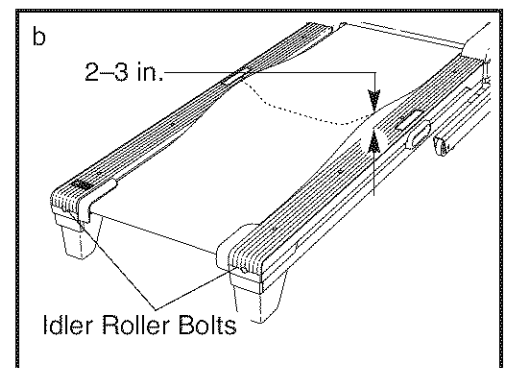

c. If the walking belt still slows when walked on, see the back cover of this manual.

PROBLEM: The walking belt is off-center or slips when walked on

SOLUTION: a. **If the walking belt is off-center**, first remove the key and **UNPLUG THE POWER CORD**. **If the walking belt has shifted to the left**, use the hex key to turn the left idler roller bolt clockwise 1/2 of a turn; **if the walking belt has shifted to the right**, turn the bolt counterclockwise 1/2 of a turn. Be careful not to overtighten the walking belt. Then, plug in the power cord, insert the key, and run the treadmill for a few minutes. Repeat until the walking belt is centered.

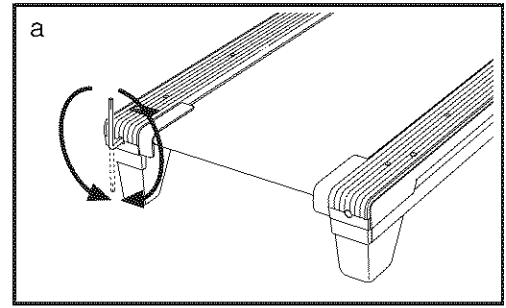

b. **If the walking belt slips when walked on**, first remove the key and **UNPLUG THE POWER CORD**. Using the hex key, turn both idler roller bolts clockwise, 1/4 of a turn. When the walking belt is correctly tightened, you should be able to lift each side of the walking belt 2 to 3 in. (5 to 7 cm) off the walking platform. Be careful to keep the walking belt centered. Then, plug in the power cord, insert the key, and carefully walk on the treadmill for a few minutes. Repeat until the walking belt is properly tightened.

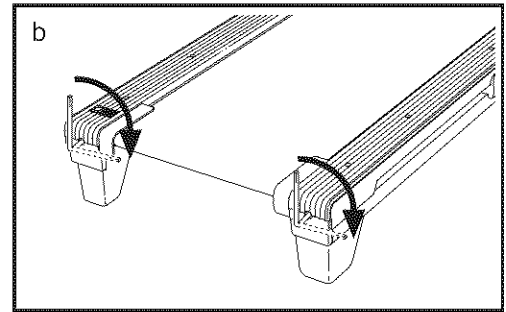

PROBLEM: The crosswalk arms squeak during use

SOLUTION: a. (Note: Correcting this problem requires a small amount of white marine grease, available at hardware stores.) Turn the Resistance Knob (88) counterclockwise and remove it. Next, remove the Resistance Cone (85) with the Crosswalk Arm (82).

Apply a **thin layer** of white marine grease to the outer surface of the Resistance Cone (85). Then, reattach the Resistance Cone with the Crosswalk Arm (82) and the Resistance Knob (88).

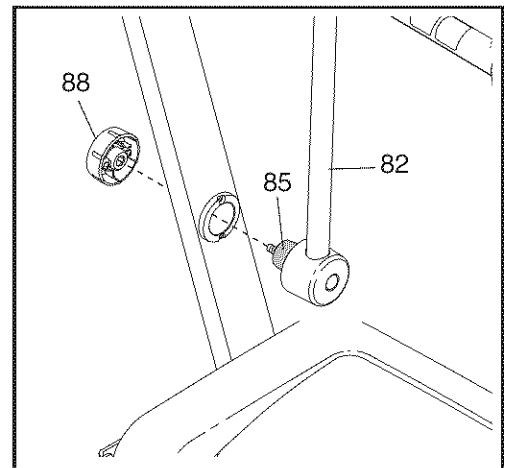

EXERCISE GUIDELINES

⚠ WARNING: Before beginning this or any exercise program, consult your physician. This is especially important for individuals over the age of 35 or individuals with pre-existing health problems.

The pulse sensor is not a medical device. Various factors, including your movement, may affect the accuracy of heart rate readings. The sensor is intended only as an exercise aid in determining heart rate trends in general.

These guidelines will help you to plan your exercise program. For detailed exercise information, obtain a reputable book or consult your physician. Remember, proper nutrition and adequate rest are essential for successful results.

EXERCISE INTENSITY

Whether your goal is to burn fat or to strengthen your cardiovascular system, exercising at the proper intensity is the key to achieving results. You can use your heart rate as a guide to find the proper intensity level. The chart below shows recommended heart rates for fat burning and aerobic exercise.

165	155	145	140	130	125	115	♥
145	138	130	125	118	110	103	♥
125	120	115	110	105	95	90	♥
20	30	40	50	60	70	80	

To find the proper intensity level, find your age at the bottom of the chart (ages are rounded off to the nearest ten years). The three numbers listed above your age define your “training zone.” The lowest number is the heart rate for fat burning, the middle number is the heart rate for maximum fat burning, and the highest number is the heart rate for aerobic exercise.

Burning Fat—To burn fat effectively, you must exercise at a low intensity level for a sustained period of time. During the first few minutes of exercise, your body uses *carbohydrate calories* for energy. Only after the first few minutes of exercise does your body begin to use stored *fat calories* for energy. If your goal is to burn fat, adjust the intensity of your exercise until your heart rate is near the lowest number in your training zone. For maximum fat burning, exercise with your heart rate near the middle number in your training zone.

Aerobic Exercise—If your goal is to strengthen your cardiovascular system, you must perform aerobic exercise, which is activity that requires large amounts of oxygen for prolonged periods of time. For aerobic exercise, adjust the intensity of your exercise until your heart rate is near the highest number in your training zone.

WORKOUT GUIDELINES

Warming up—Start with 5 to 10 minutes of stretching and light exercise. A warm-up increases your body temperature, heart rate, and circulation in preparation for exercise.

Training Zone Exercise—Exercise for 20 to 30 minutes with your heart rate in your training zone. (During the first few weeks of your exercise program, do not keep your heart rate in your training zone for longer than 20 minutes.) Breathe regularly and deeply as you exercise—never hold your breath.

Cooling down—Finish with 5 to 10 minutes of stretching. Stretching increases the flexibility of your muscles and helps to prevent post-exercise problems.

EXERCISE FREQUENCY

To maintain or improve your condition, complete three workouts each week, with at least one day of rest between workouts. After a few months of regular exercise, you may complete up to five workouts each week, if desired. Remember, the key to success is to make exercise a regular and enjoyable part of your everyday life.

PART LIST—Model No. 831.24824.1

R0708B

To locate the parts listed below, see the EXPLODED DRAWING near the end of this manual.

Key No.	Qty.	Description	Key No.	Qty.	Description
1	25	#8 x 3/4" Screw	51	1	Walking Platform
2	4	#8 x 1" Tek Screw	52	1	Drive Roller/Pulley
3	2	3/8" x 4 3/4" Bolt	53	1	Latch Cap
4	4	M8 x 25mm Bolt	54	1	Storage Latch
5	1	3/8" x 1 1/2" Bolt	55	1	Latch Knob
6	1	3/8" x 1 3/4" Bolt	56	1	Right Foot Rail
7	4	M10 x 96mm Bolt	57	1	Frame
8	4	M10 Star Washer	58	2	Idler Roller Bracket
9	4	M8 Star Washer	59	1	Right Rear Foot
10	5	#8 x 3/4" Tek Screw	60	2	Idler Roller Bracket Plate
11	2	3/8" Locknut	61	1	Idler Roller
12	20	#8 x 5/8" Screw	62	1	Left Rear Foot
13	2	Small Cap	63	1	Motor Hood
14	2	M8 x 35mm Bolt	64	1	Drive Motor
15	2	M8 x 90mm Bolt	65	3	Cable Tie
16	2	M10 x 30mm Bolt	66	1	Lift Frame
17	1	3/8" x 1 3/4" Bolt	67	2	Lift Frame Spacer
18	1	3/8" x 1 1/2" Bolt	68	1	Incline Stop Bracket
19	2	3/8" x 1" Bolt	69	1	Reed Switch
20	1	M6 x 44mm Bolt	70	1	Reed Switch Clamp
21	1	Left Handrail	71	1	Lift Frame Ground Wire
22	8	M5.5 x 25mm Screw	72	1	Lift Motor
23	2	1/4" Motor Bolt	73	1	Lift Motor Spacer
24	2	3/8" x 1" Bolt	74	1	Controller
25	1	3/8" x 4" Bolt	75	1	Power Cord
26	2	M10 x 50mm Bolt	76	1	Power Cord Grommet
27	4	#8 x Belt Guide Screw	77	1	Reset/Off Circuit Breaker
28	2	Idler Roller Bolt	78	1	Belly Pan
29	8	#8 x 1/2" Ground Screw	79	1	Left Upright
30	2	1/4" Lock Washer	80	1	Right Upright
31	2	1/4" Flat Washer	81	2	Crosswalk Arm Handgrip
32	1	3/8" Star Washer	82	2	Crosswalk Arm
33	1	3/8" Flat Washer	83	1	Left Foot Rail
34	3	3/8" Jam Nut	84	2	Upright Insert
35	2	3/8" Flange Nut	85	2	Resistance Cone
36	4	M10 Locknut	86	2	Resistance Cone Insert
37	4	M8 Flange Nut	87	2	Arm Insert
38	3	Hood Clip	88	2	Resistance Knob
39	4	M8 Cage Nut	89	1	Left Upright Spacer
40	1	6mm Hex Key	90	1	Right Upright Spacer
41	1	4mm Hex Key	91	2	Base Cap
42	1	5mm Hex Key	92	1	Wire Harness
43	1	Hex Key	93	4	Base Foot
44	1	Warning Decal	94	2	Base Foot Spacer
45	2	Platform Cushion	95	2	Wheel
46	2	Belt Guide	96	1	Base Ground Wire
47	2	Frame Cap	97	2	Warning Decal
48	1	Magnet	98	4	Bolt Spacer
49	1	Drive Roller Belt	99	1	Base
50	1	Walking Belt	100	1	Right Handrail

Key No.	Qty.	Description	Key No.	Qty.	Description
101	1	Filter Wire	111	1	Releasable Tie
102	4	Handrail Cap	112	1	Drive Motor Bracket
103	1	Console Base	113	7	8" Cable Tie
104	1	Book Holder	*	–	12" Blue Wire, 2F
105	1	Fan Grill	*	–	6" Blue Wire, 2F
106	1	Fan Housing/Fan	*	–	10" Blue Wire, M/F
107	1	7 1/2" Cable Tie	*	–	4" Black Wire, M/F
108	1	Console	*	–	8" Green Wire, F/R
109	1	Key/Clip	*	–	8" Red Wire, M/F
110	4	15 1/2" Cable Tie	*	–	User's Manual

Note: Specifications are subject to change without notice. See the back cover of this manual for information about ordering replacement parts. **If a part is missing, call 1-888-533-1333.** *These parts are not illustrated.

28

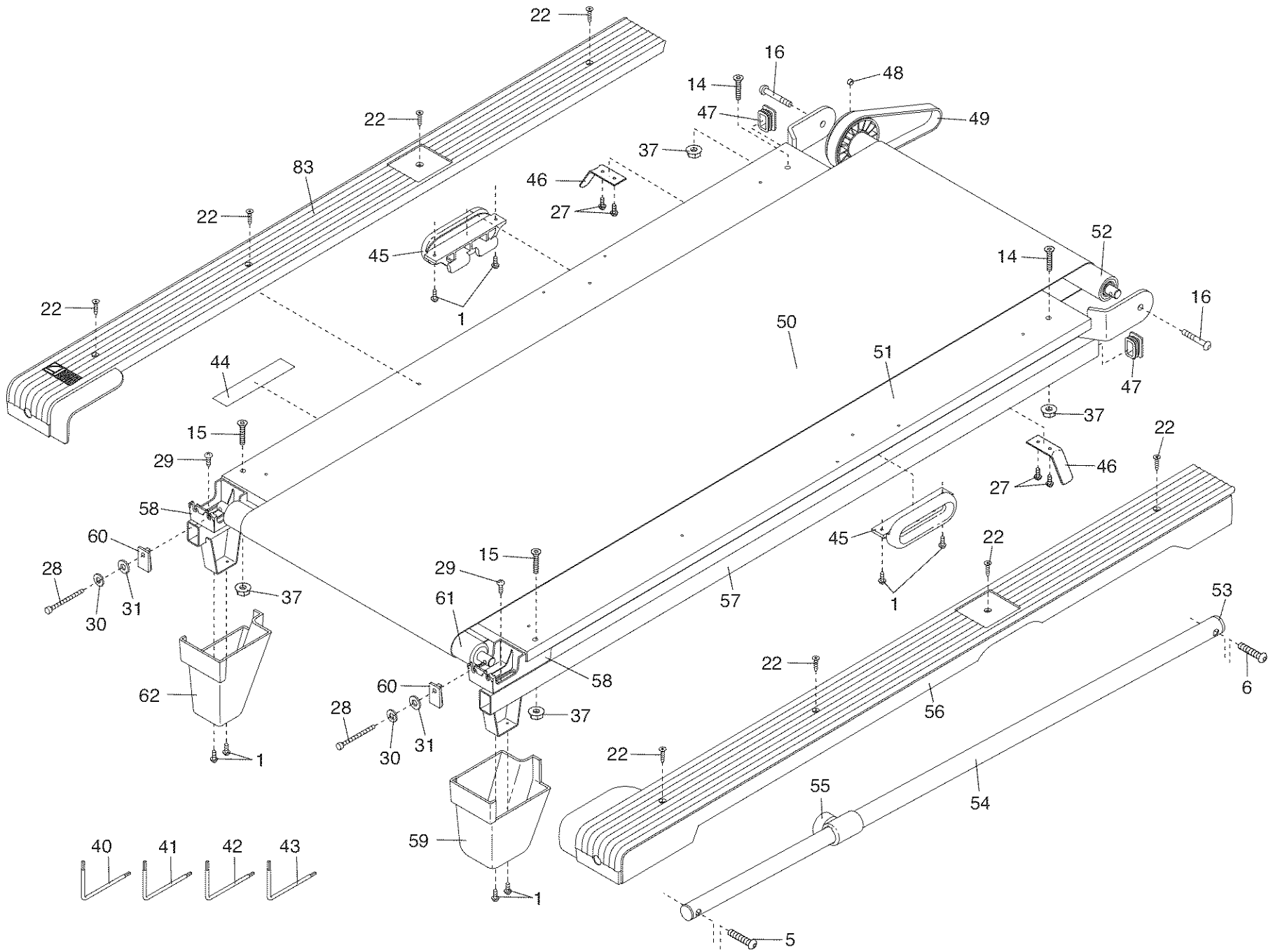

EXPLODED DRAWING A—Model No. 831.24824.1

R0708B

EXPLODED DRAWING B—Model No. 831.24824.1

R0708B

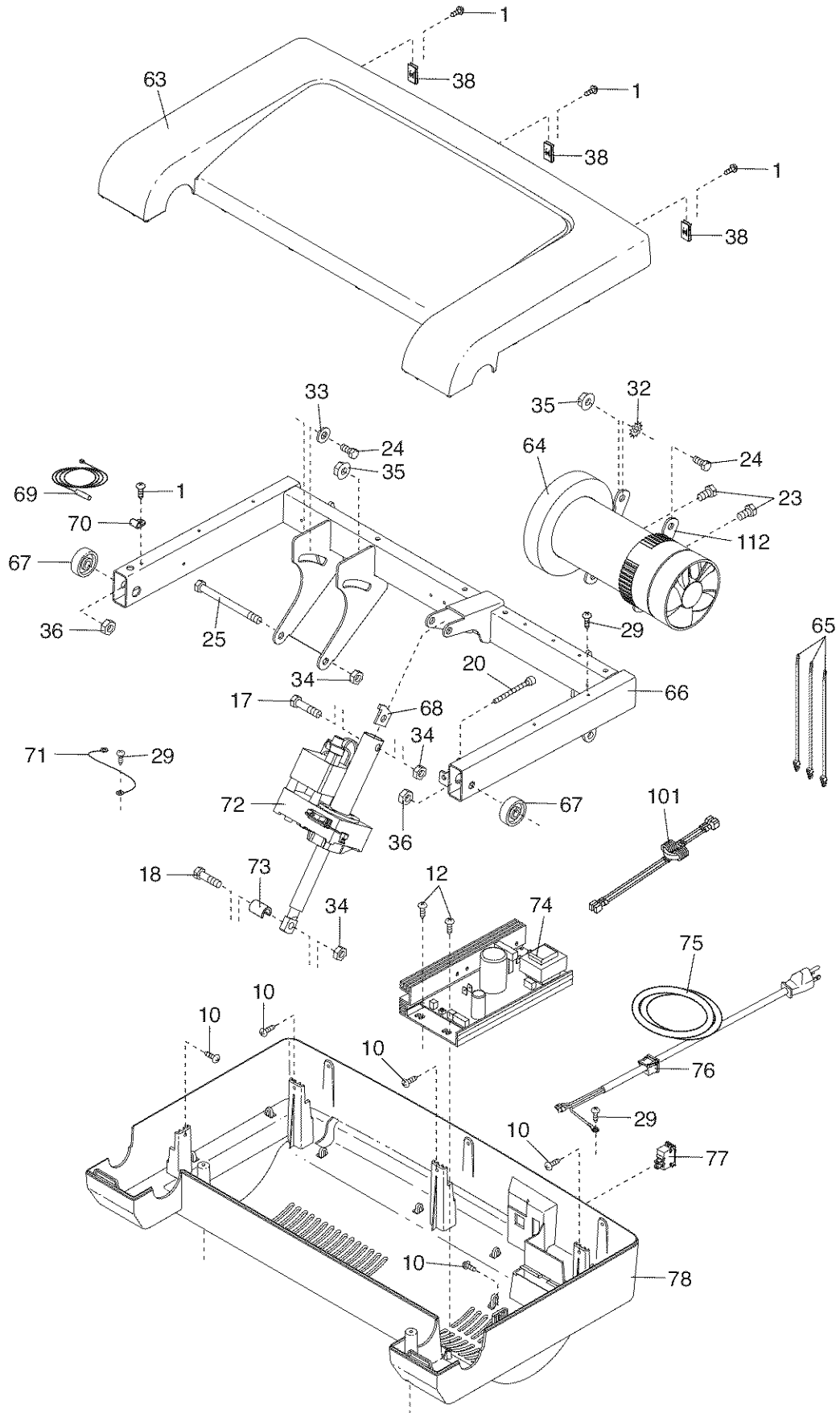

EXPLODED DRAWING C—Model No. 831.24824.1

R0708B

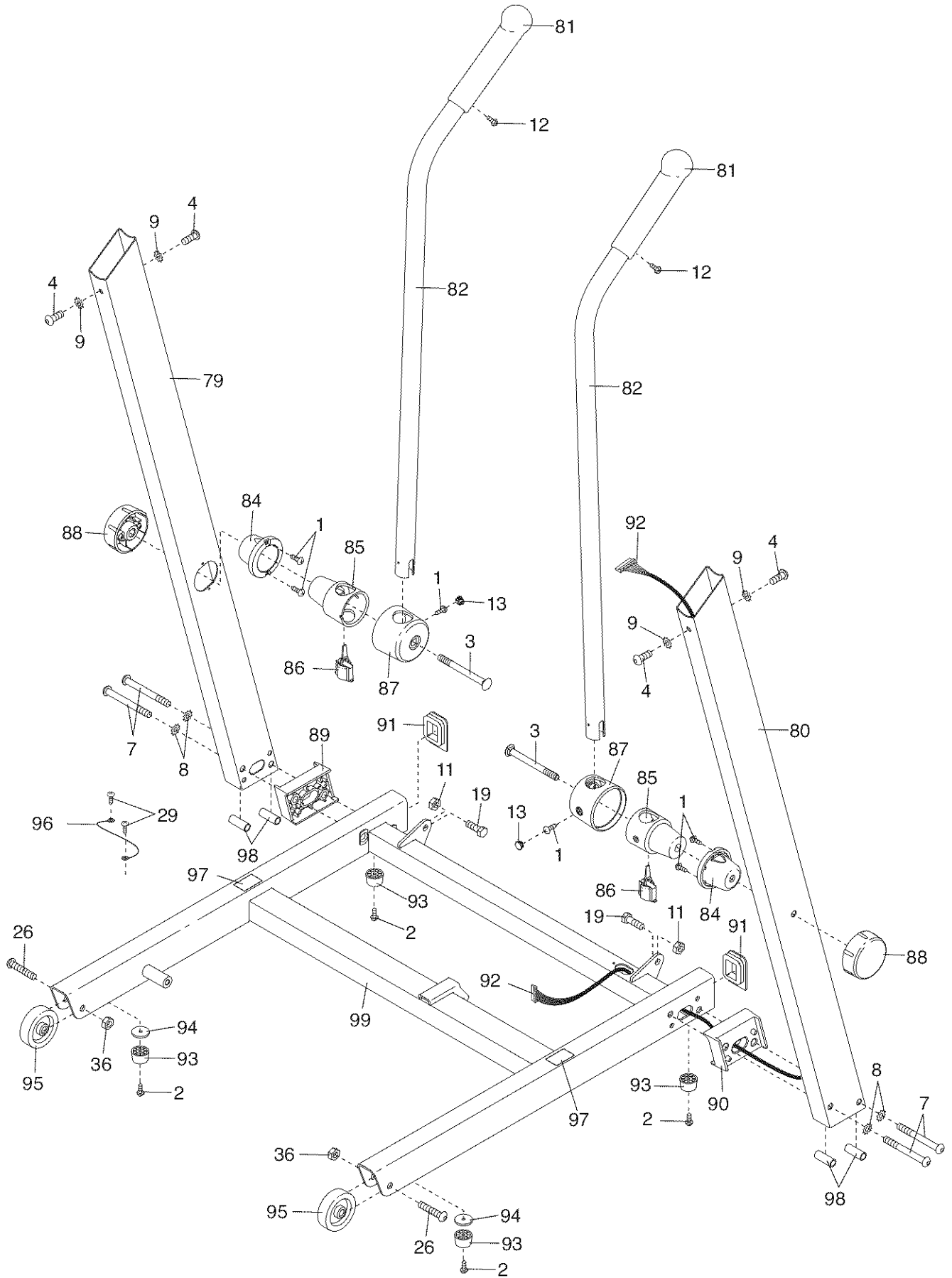

EXPLODED DRAWING D—Model No. 831.24824.1

R0708B

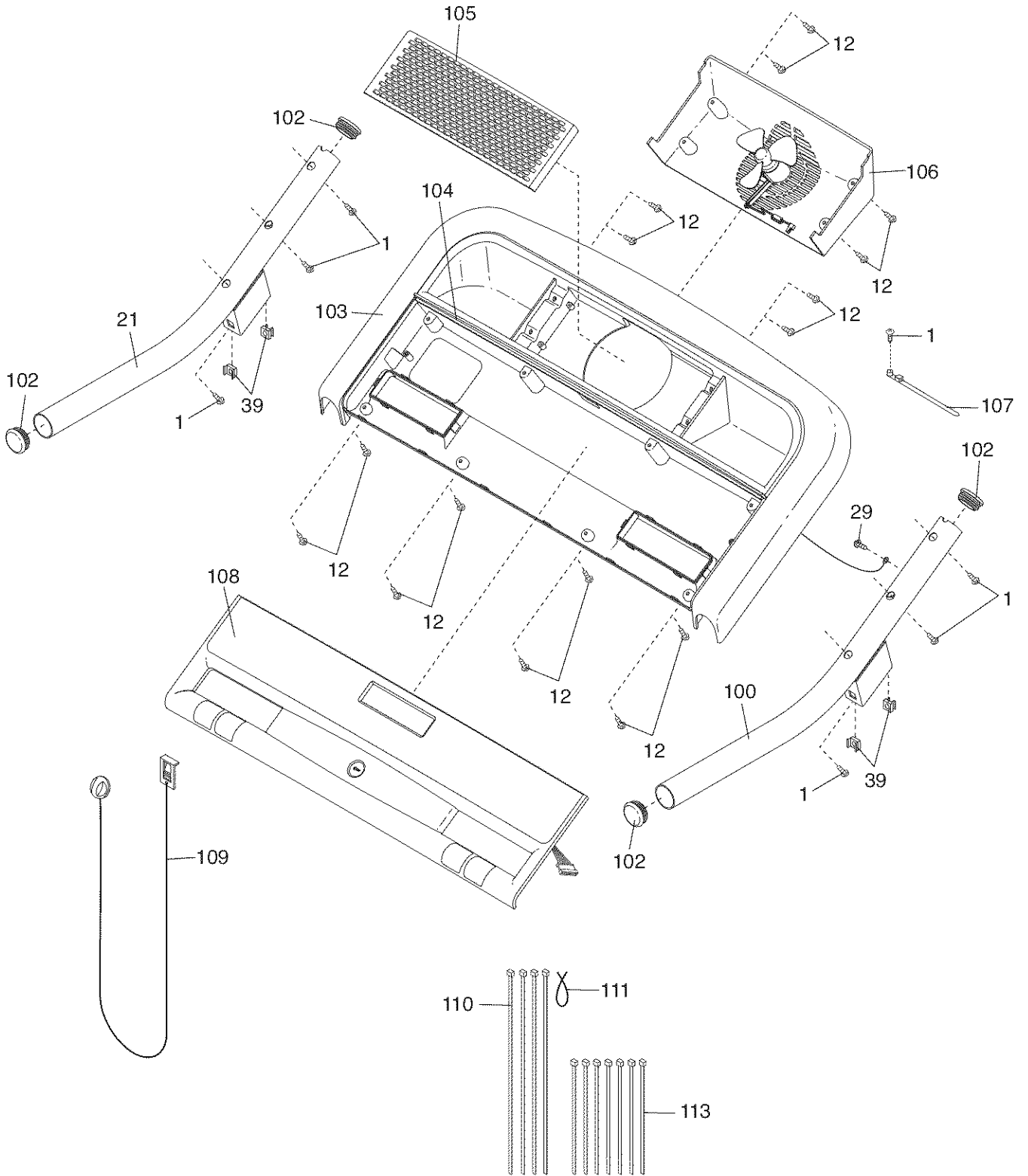

Get it fixed, at your home or ours!

Your Home

For repair—**in your home**—of **all** major brand appliances, lawn and garden equipment, or heating and cooling systems, **no matter who made it, no matter who sold it!**

For the replacement parts, accessories, and user's manuals that you need to do-it-yourself.

For Sears professional installation of home appliances and items like garage door openers and water heaters.

1-800-4-MY-HOME® (1-800-469-4663)

Call anytime, day or night (U.S.A. and Canada)

www.sears.com

www.sears.ca

Our Home

For repair of carry-in items like vacuums, lawn equipment, and electronics, call or go on-line for the location of your nearest **Sears Parts & Repair Center.**

1-800-488-1222 Call anytime, day or night (U.S.A. only)

www.sears.com

To purchase a protection agreement (U.S.A.) or maintenance agreement (Canada) on a product serviced by Sears:

1-800-827-6655 (U.S.A.)

1-800-361-6665 (Canada)

Para pedir servicio de reparación a domicilio, y para ordenar piezas:

1-888-SU-HOGAR® (1-888-784-6427)



® Registered Trademark / ™ Trademark / ™ Service Mark of Sears Brands, LLC
® Marca Registrada / ™ Marca de Fábrica / ™ Marca de Servicio de Sears Brands, LLC

90 DAY FULL WARRANTY

If this Sears Treadmill Exerciser fails due to a defect in material or workmanship within 90 days of the date of purchase, call 1-800-4-MY-HOME® (1-800-469-4663) to arrange for free repair (or replacement if repair proves impossible). The incline motor is warranted for 90 days from the date of purchase; the drive motor is warranted for 7 years from the date of purchase.

This warranty does not apply when the Treadmill Exerciser is used commercially or for rental purposes.

This warranty gives you specific legal rights, and you may also have other rights which vary from state to state.

Sears, Roebuck and Co., Hoffman Estates, IL 60179