

Safety Instructions & Operator's Manual for
SNAPPER[®]
ZERO-TURN RIDING MOWER

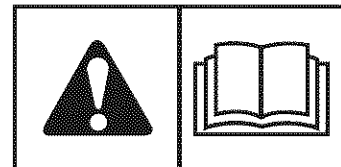

500Z Series

26HP Zero-Turn Riders

Mfg. No.	Description
5900731	500ZB2648 Snapper 26HP 500Z Zero-Turn Rider with 48" Mower

Thank you for purchasing this quality-built Snapper product. We're pleased that you've placed your confidence in the Snapper brand. When operated and maintained according to the instructions in this manual, your Snapper product will provide many years of dependable service.

This manual contains safety information to make you aware of the hazards and risks associated with this machine and how to avoid them. This machine is designed and intended to be used and maintained according to the manual for finish cutting of established lawns and is not intended for any other purpose. It is important that you read and understand these instructions thoroughly before attempting to start or operate this equipment

PRODUCT REFERENCE DATA	
Unit Model Number	Unit SERIAL Number
Mower Deck Model Number	Mower Deck SERIAL Number
Dealer Name	Date Purchased
ENGINE REFERENCE DATA	
Engine Make	Engine Model
Engine Type/Spec.	Engine Code/Serial Number

See **Features and Controls** for the location of Identification Numbers

DATE PURCHASED

--	--	--	--	--	--

⚠ WARNING

Engine exhaust from this product contains chemicals known, in certain quantities, to cause cancer, birth defects, or other reproductive harm.

Copyright © 2008 Briggs & Stratton Corporation
Milwaukee, WI, USA. All rights reserved.

The Snapper logo is a trademark of Briggs & Stratton Corporation Milwaukee, WI, USA.

Contact Information:
Snapper Products
535 Macon St.
McDonough, GA 30253
www.snapper.com

Table of Contents

Operator Safety	2
Safety Rules and Information	2
Safety Decals	8
Safety Interlock System	9
Features & Controls	10
Identification Numbers	10
Control Functions	11
Operation	13
General	13
Checks Before Starting	13
Checking Tire Pressures	14
Seat Adjustment	14
Mowing Height Adjustment	15
Foot Pedal Adjustment.....	15
Starting the Engine	16
Stopping the Rider.....	16
Pushing the Rider by Hand.....	16
Zero Turn Driving Practice	17
Mowing.....	19
Mowing Reccomendations	19
Mowing Methods.....	20
Attaching a Trailer.....	21
Regular Maintenance	22
Maintenance Schedule.....	22
Checking/Adding Fuel.....	23
Fuel Filter.....	23
Oil & Filter Change.....	23
Lubrication.....	24
Check Transmission Oil Level.....	25
Transmission Oil Filter Change	25
Servicing the Mower Blades	26
Ground Speed Control Lever Adjustment	28
Speed Balancing Adjustment	28
Neutral Adjustment.....	28
Parking Brake Adjustment	29
Return to Neutral Adjustment.....	30
Deck Rod Timing Adjustment.....	31
Deck Leveling Adjustment	31
Mower Belt Replacement.....	32
Hydraulic Pump Drive Belt Replacement.....	33
Battery Maintenance.....	34
Battery Service	35
Storage.....	37
Starting After Long Term Storage.....	37
Troubleshooting	38
Troubleshooting the Rider	38
Troubleshooting the Mower.....	39
Troubleshooting Common Cutting Problems.....	40
Specifications	41
Slope Identification Guide	42

NOTE: In this manual, "left" and "right" are referred to as seen from the operating position.

Operator Safety Safety Rules and Information

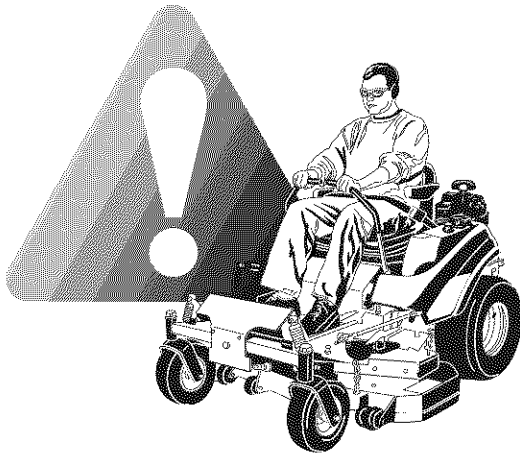

OPERATING SAFETY

Congratulations on purchasing a superior-quality piece of lawn and garden equipment. Our products are designed and manufactured to meet or exceed all industry standards for safety.

Do not operate this machine unless you have been trained. Reading and understanding this operator's manual is a way to train yourself.

Power equipment is only as safe as the operator. If it is misused, or not properly maintained, it can be dangerous! Remember, you are responsible for your safety and that of those around you.

Use common sense, and think through what you are doing. If you are not sure that the task you are about to perform can be safely done with the equipment you have chosen, ask a professional: contact your local authorized dealer.

READ THE MANUAL

The operator's manual contains important safety information you need to be aware of **BEFORE** you operate your unit as well as **DURING** operation.

Safe operating techniques, an explanation of the product's features and controls, and maintenance information is included to help you get the most out of your equipment investment.

Be sure to completely read the Safety Rules and Information found on the following pages. Also completely read the Operation section.

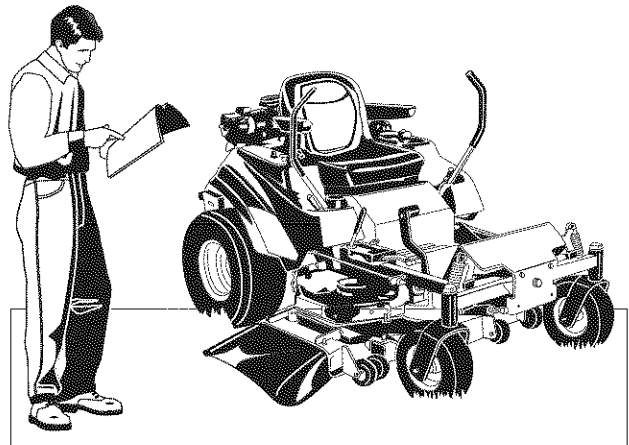

CHILDREN

Tragic accidents can occur with children. Do not allow them anywhere near the area of operation. Children are often attracted to the unit and mowing activity. Never assume that children will remain where you last saw them. If there is a risk that children may enter the area where you are mowing, have another responsible adult watch them.

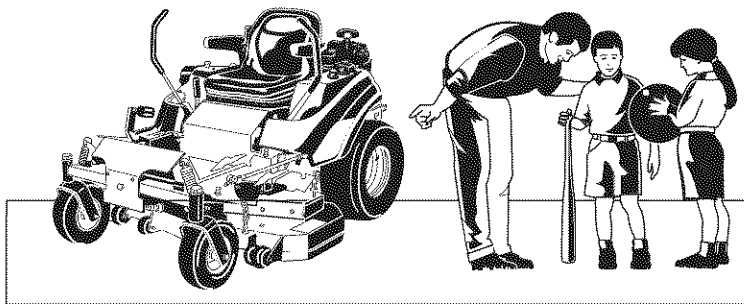

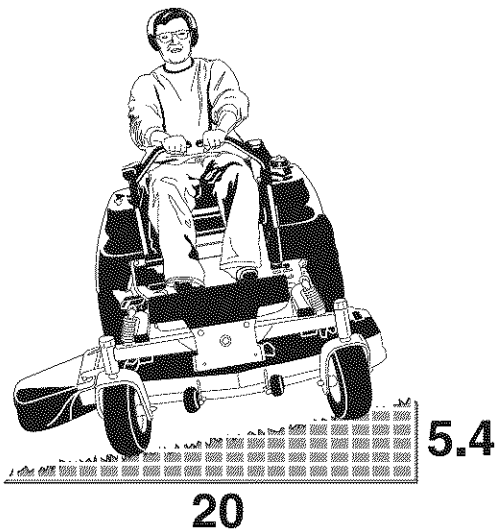

SLOPE OPERATION

Operation on slopes can be dangerous. Using the unit on a slope that is too steep where you do not have adequate wheel traction (and control) can cause sliding, loss of steering, control, and possible rollover. You should not operate on a slope greater than a 5.4 foot rise over a 20 foot length (15 degrees).

Always mow across slopes, not up and down (to maintain traction on the wheels) and avoid sudden turns or rapid speed changes. Reduce speed and use extreme caution on ALL slopes.

Also, note that the surface condition you are on can greatly impact your ability to safely operate this machine. Operating on wet or slippery slopes can cause sliding and loss of steering and control. Do not operate on slopes that are slippery, wet, or have soft soil conditions.

If you feel unsure about operating the unit on a slope, don't do it. It's not worth the risk.

THROWN OBJECTS

This unit has spinning mower blades. These blades can pick up and throw debris that could seriously injure a bystander. Be sure to clean up the area to be mowed and remove objects that could be thrown by the blade **BEFORE** you start mowing.

Do not operate this unit without the entire grass catcher or discharge guard (deflector) in place.

Also, do not allow anyone in the area while the unit is running! If someone does enter the area, shut the unit off immediately until they leave.

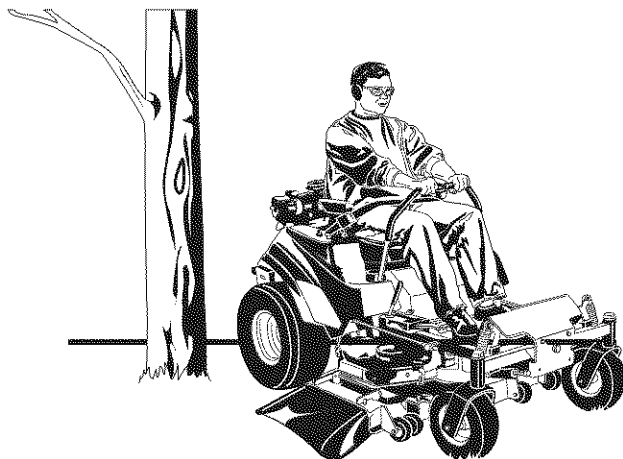
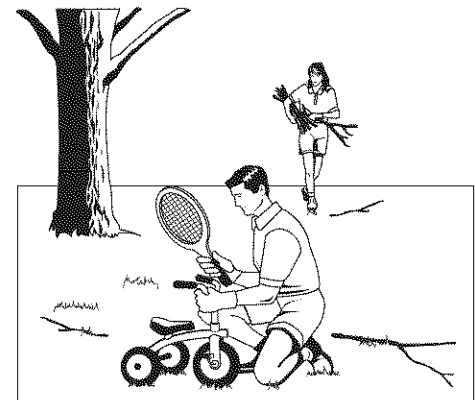

MOVING PARTS

This equipment has many moving parts that can injure you or someone else. However, if you stay in the operator zone (stay seated in the seat), and follow the safety rules in this operator's manual, the unit is safe to operate.

The mower deck has spinning mower blades that can amputate hands and feet. Do not allow anyone near the unit while it is running! Keep safety devices (guards, shields, and switches) in place and working.

To help you, the operator, use this equipment safely, it is equipped with an operator-present safety system. Do NOT attempt to alter or bypass the system. See your dealer immediately if the system does not pass all the safety interlock system tests found in this manual.

RETAINING WALLS, DROP-OFFS, AND WATER

Retaining walls and drop-offs around steps and water are a common hazard. Give yourself a minimum of two mower widths of clearance around these hazards and hand-trim with a walk behind mower or string trimmer. Wheels dropping over retaining walls, edges, ditches, embankments, or into water can cause rollovers, which may result in serious injury, death, or drowning.

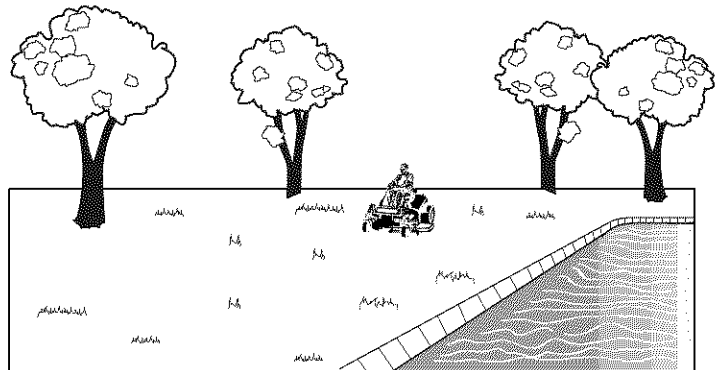
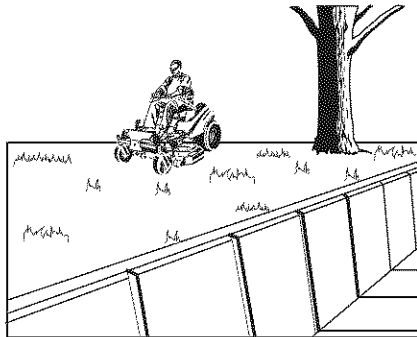

FUEL AND MAINTENANCE

Always disengage all drives, shutoff the engine, and remove the key before doing any cleaning, refueling, or servicing.

Gasoline and its vapors are extremely flammable. Do not smoke while operating or refueling. Do not add fuel while engine is hot or running. Allow engine to cool for at least 3 minutes prior to adding fuel.

Do not add fuel indoors, in an enclosed trailer, garage, or any other enclosed area that is not well ventilated. Gasoline spills should be cleaned up promptly and before operation begins.

Gasoline should be stored only in sealed containers approved for fuel.

Proper maintenance is critical to the safety and performance of your unit. Keep the unit free of grass, leaves, and excess oil. Be sure to perform the maintenance procedures listed in this manual, especially periodically testing the safety system.

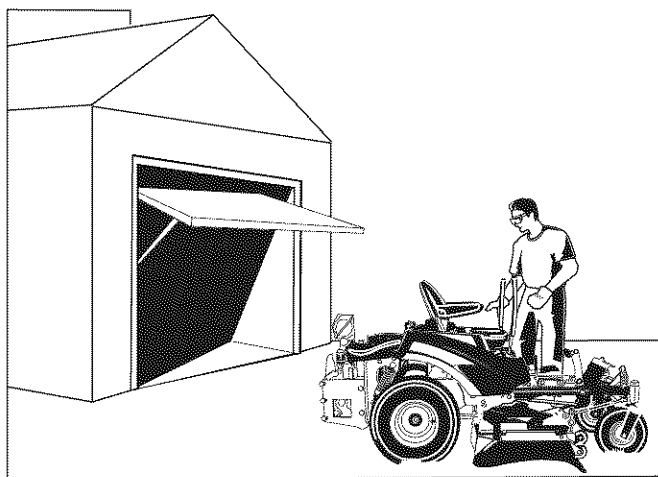
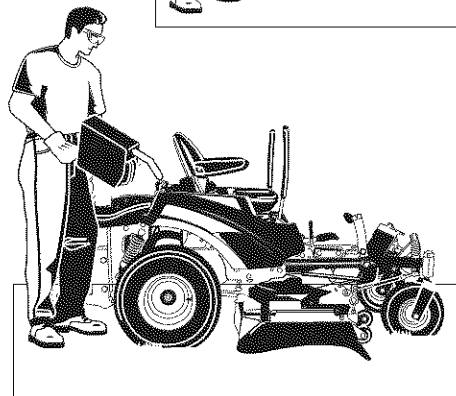
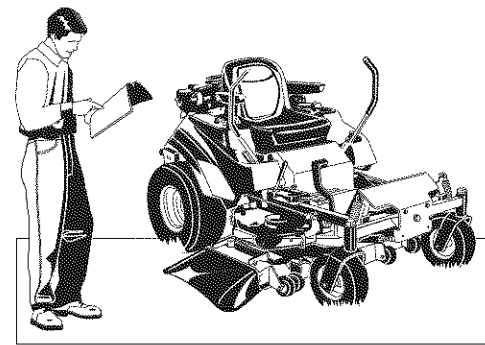

ENCLOSED AREAS

Only operate this unit outdoors and away from unventilated areas such as inside garages or enclosed trailers. The engine emits poisonous carbon monoxide gas and prolonged exposure in an enclosed area can result in serious injury or death.



Read these safety rules and follow them closely. Failure to obey these rules could result in loss of control of unit, severe personal injury or death to you, or bystanders, or damage to property or equipment.

This mowing deck is capable of amputating hands and feet and throwing objects. The triangle  in text signifies important cautions or warnings which must be followed.

GENERAL OPERATION

1. Read, understand, and follow all instructions in the manual and on the unit before starting.
2. Do not put hands or feet near rotating parts or under the machine. Keep clear of the discharge opening at all times.
3. Only allow responsible adults, who are familiar with the instructions, to operate the unit (local regulations can restrict operator age).
4. Clear the area of objects such as rocks, toys, wire, etc., which could be picked up and thrown by the blade(s).
5. Be sure the area is clear of other people before mowing. Stop the unit if anyone enters the area.
6. Never carry passengers.
7. Do not mow in reverse unless absolutely necessary. Always look down and behind before and while travelling in reverse.
8. Never direct discharge material toward anyone. Avoid discharging material against a wall or obstruction. Material may ricochet back toward the operator. Stop the blade(s) when crossing gravel surfaces.
9. Do not operate the machine without the entire grass catcher, discharge guard (deflector), or other safety devices in place and operational.
10. Slow down before turning.
11. Never leave a running unit unattended. Always disengage the blades (PTO), set parking brake, stop engine, and remove keys before dismounting.
12. Disengage blades (PTO) when not mowing. Shut off engine and wait for all parts to come to a complete stop before cleaning the machine, removing the grass catcher, or unclogging the discharge guard.
13. Operate the machine only in daylight or good artificial light.
14. Do not operate the unit while under the influence of alcohol or drugs.
15. Watch for traffic when operating near or crossing roadways.
16. Use extra care when loading or unloading the unit into a trailer or truck.
17. Always wear eye protection when operating this unit.
18. Data indicates that operators, age 60 years and above, are involved in a large percentage of power equipment-related injuries. These operators should evaluate their ability to operate the equipment safely enough to protect themselves and others from injury.
19. Follow the manufacturer's recommendations for wheel weights or counterweights.
20. Keep in mind the operator is responsible for accidents occurring to other people or property.
21. All drivers should seek and obtain professional and practical instruction.
22. Always wear substantial footwear and trousers. Never operate when barefoot or wearing sandals.
23. Before using, always visually check that the blades and blade hardware are present, intact, and secure. Replace worn or damaged parts.
24. Disengage attachments before: refueling, removing an attachment, making adjustments (unless the adjustment can be made from the operator's position).
25. When the machine is parked, stored, or left unattended, lower the cutting means unless a positive mechanical lock is used.
26. Before leaving the operator's position for any reason, engage the parking brake (if equipped), disengage the blades (PTO), stop the engine, and remove the key.
27. To reduce fire hazard, keep the unit free of grass, leaves, & excess oil. Do not stop or park over dry leaves, grass, or combustible materials.
28. It is a violation of California Public Resource Code Section 4442 to use or operate the engine on or near any forest-covered, brush-covered, or grass-covered land unless the exhaust system is equipped with a spark arrester meeting any applicable local or state laws. Other states or federal areas may have similar laws.
29. OSHA regulations may require the use of hearing protection when exposed to sound levels greater than 85 dBA for an 8 hour time period.

CAUTION



This machine produces sound levels in excess of 85 dBA at the operator's ear and can cause hearing loss through extended periods of exposure.

Wear hearing protection when operating this machine.

TRANSPORTING AND STORAGE

1. When transporting the unit on an open trailer, make sure it is facing forward, in the direction of travel. If the unit is facing backwards, wind lift could damage the unit.
2. Always observe safe refueling and fuel handling practices when refueling the unit after transportation or storage.
3. Never store the unit (with fuel) in an enclosed poorly ventilated structure. Fuel vapors can travel to an ignition source (such as a furnace, water heater, etc.) and cause an explosion. Fuel vapor is also toxic to humans and animals.
4. Always follow the engine manual instructions for storage preparations before storing the unit for both short and long term periods.
5. Always follow the engine manual instructions for proper start-up procedures when returning the unit to service.
6. Never store the unit or fuel container inside where there is an open flame or pilot light, such as in a water heater. Allow unit to cool before storing.

SLOPE OPERATION

Slopes are a major factor related to loss-of-control and tip-over accidents, which can result in severe injury or death. Operation on all slopes requires extra caution. If you cannot back up the slope or if you feel uneasy on it, do not operate on it.

Control of a walk-behind or ride-on machine sliding on a slope will not be regained by the application of the brake. The main reasons for loss of control are: insufficient tire grip on the ground, speed too fast, inadequate braking, the type of machine is unsuitable for its task, lack of awareness of the ground conditions, incorrect hitching and load distribution.

1. Mow across slopes, not up and down.
2. Watch for holes, ruts, or bumps. Uneven terrain could overturn the unit. Tall grass can hide obstacles.
3. Choose a slow speed so that you will not have to stop or change speeds while on the slope.
4. Do not mow on wet grass. Tires may lose traction.
5. Avoid starting, stopping, or turning on a slope. If tires lose traction (i.e. machine stops forward motion on a slope), disengage the blade(s) (PTO) and drive slow off the slope.
6. Keep all movement on slopes slow and gradual. Do not make sudden changes in speed or direction, which could cause the machine to rollover.
7. Use extra care while operating machines with grass catchers or other attachments; they can affect the stability of the unit. Do not use on steep slopes.
8. Do not try to stabilize the machine by putting your foot on the ground (ride-on units).
9. Do not mow near drop-offs, ditches, or embankments. The mower could suddenly turn over if a wheel is over the edge of a cliff or ditch, or if an edge caves in.
10. Do not use grass catchers on steep slopes.
11. Do not mow slopes if you cannot back up them.
12. See your authorized dealer/retailer for recommendations of wheel weights or counterweights to improve stability.
13. Remove obstacles such as rocks, tree limbs, etc.
14. Use slow speed. Tires may lose traction on slopes even though the brakes are functioning properly.
15. Do not turn on slopes unless necessary, and then, turn slowly and gradually uphill, if possible. Never mow down slopes.

TOWED EQUIPMENT (RIDE-ON UNITS)

1. Tow only with a machine that has a hitch designed for towing. Do not attach towed equipment except at the hitch point.
2. Follow the manufacturer's recommendations for weight limit for towed equipment and towing on slopes. See

WARNING

Never operate on slopes greater than 15° which is a rise of 5.4 feet (1.6 m) vertically in 20 feet (6 m) horizontally.

Select slow ground speed before driving onto slope. Use extra caution when operating on slopes with rear-mounted grass catchers.

Mow across the face of slopes, not up and down, use caution when changing directions and DO NOT START OR STOP ON SLOPE.

- attaching a trailer under OPERATION.
3. Never allow children or others in or on towed equipment.
4. On slopes, the weight of the towed equipment may cause loss of traction and loss of control.
5. Travel slowly and allow extra distance to stop.
6. Do not shift to neutral and coast down hill.

CHILDREN

Tragic accidents can occur if the operator is not alert to the presence of children. Children are often attracted to the unit and the mowing activity. Never assume that children will remain where you last saw them.

1. Keep children out of the mowing area and under the watchful care of another responsible adult.
2. Be alert and turn unit off if children enter the area.
3. Before and during reverse operation, look behind and down for small children.
4. Never carry children, even with the blade(s) off. They may fall off and be seriously injured or interfere with safe unit operation. Children who have been given rides in the past may suddenly appear in the mowing area for another ride and be run over or backed over by the machine.
5. Never allow children to operate the unit.
6. Use extra care when approaching blind corners, shrubs, trees, or other objects that may obscure vision.

EMISSIONS

1. Engine exhaust from this product contains chemicals known, in certain quantities, to cause cancer, birth defects, or other reproductive harm.
2. Look for the relevant Emissions Durability Period and Air Index information on the engine emissions label.

IGNITION SYSTEM

1. This spark ignition system complies with Canadian ICES-002.

SERVICE AND MAINTENANCE

Safe Handling of Gasoline

1. Extinguish all cigarettes, cigars, pipes, and other sources of ignition.
2. Use only approved gasoline containers.
3. Never remove the gas cap or add fuel with the engine running. Allow the engine to cool before refueling.
4. Never fuel the machine indoors.
5. Never store the machine or fuel container where there is an open flame, spark, or pilot light such as near a water heater or other appliance.
6. Never fill containers inside a vehicle or on a truck bed with a plastic bed liner. Always place containers on the ground away from your vehicle before filling.
7. Remove gas-powered equipment from the truck or trailer and refuel it on the ground. If this is not possible, then refuel such equipment on a trailer with a portable container, rather than from a gasoline dispenser nozzle.
8. Keep nozzle in contact with the rim of the fuel tank or container opening at all times until fueling is complete. Do not use a nozzle lock-open device.
9. If fuel is spilled on clothing, change clothing immediately.
10. Never over-fill the fuel tank. Replace gas cap and tighten securely.
11. Use extra care in handling gasoline and other fuels. They are flammable and vapors are explosive.
12. If fuel is spilled, do not attempt to start the engine but move the machine away from the area of spillage and avoid creating any source of ignition until fuel vapors have dissipated.
13. Replace all fuel tank caps and fuel container caps securely.

Service & Maintenance

1. Never run the unit in an enclosed area where carbon monoxide fumes may collect.
2. Keep nuts and bolts, especially blade attachment bolts, tight and keep equipment in good condition.
3. Never tamper with safety devices. Check their proper operation regularly and make necessary repairs if they are not functioning properly.
4. Keep unit free of grass, leaves, or other debris build-up. Clean up oil or fuel spillage, and remove any fuel-soaked debris. Allow machine to cool before storage.
5. If you strike an object, stop and inspect the machine. Repair, if necessary, before restarting.
6. Never make adjustments or repairs with the engine running.
7. Check grass catcher components and the discharge guard frequently and replace with manufacturer's recommended parts, when necessary.
8. Mower blades are sharp. Wrap the blade or wear gloves, and use extra caution when servicing them.
9. Check brake operation frequently. Adjust and service as required.
10. Maintain or replace safety and instructions labels, as necessary.
11. Do not remove the fuel filter when the engine is hot as spilled gasoline may ignite. Do not spread fuel line clamps further than necessary. Ensure clamps grip hoses firmly over the filter after installation.
12. Do not use gasoline containing METHANOL, gasohol containing more than 10% ETHANOL, gasoline additives,

or white gas because engine/fuel system damage could result.

13. If the fuel tank must be drained, it should be drained outdoors.
14. Replace faulty silencers/mufflers.
15. Maintain or replace safety and instruction labels as necessary.
16. Use only factory authorized replacement parts when making repairs.
17. Always comply with factory specifications on all settings and adjustments.
18. Only authorized service locations should be utilized for major service and repair requirements.
19. Never attempt to make major repairs on this unit unless you have been properly trained. Improper service procedures can result in hazardous operation, equipment damage and voiding of manufacturer's warranty.
20. On multiple blade mowers, take care as rotating one blade can cause other blades to rotate.
21. Do not change engine governor settings or over-speed the engine. Operating the engine at excessive speed can increase the hazard of personal injury.
22. Disengage drive attachments, stop the engine, remove the key, and disconnect the spark plug wire(s) before: clearing attachment blockages and chutes, performing service work, striking an object, or if the unit vibrates abnormally. After striking an object, inspect the machine for damage and make repairs before restarting and operating the equipment.
23. Never place hands near the moving parts, such as a hydro pump cooling fan, when the tractor is running. (Hydro pump cooling fans are typically located on top of the transaxle).
24. Units with hydraulic pumps, hoses, or motors: **WARNING:** Hydraulic fluid escaping under pressure may have sufficient force to penetrate skin and cause serious injury. If foreign fluid is injected into the skin it must be surgically removed within a few hours by a doctor familiar with this form of injury or gangrene may result. Keep body and hands away from pin holes or nozzles that eject hydraulic fluid under high pressure. Use paper or cardboard, and not hands, to search for leaks. Make sure all hydraulic fluid connections are tight and all hydraulic hoses and lines are in good condition before applying pressure to the system. If leaks occur, have the unit serviced immediately by your authorized dealer.
25. **WARNING:** Stored energy device. Improper release of springs can result in serious personal injury. Springs should be removed by an authorized technician.
26. Models equipped with an engine radiator: **WARNING:** Stored energy device. To prevent serious bodily injury from hot coolant or steam blow-out, never attempt to remove the radiator cap while the engine is running. Stop the engine and wait until it is cool. Even then, use extreme care when removing the cap.

Safety Decals

This unit has been designed and manufactured to provide you with the safety and reliability you would expect from an industry leader in outdoor power equipment manufacturing.

Although reading this manual and the safety instructions it contains will provide you with the necessary basic knowledge to operate this equipment safely and effectively, we have placed several safety labels on the unit to remind you of this important information while you are operating your unit.

All DANGER, WARNING, CAUTION and instructional messages on your rider and mower should be carefully read and obeyed. Personal bodily injury can result when these instructions are not followed. The information is for your safety and it is important! The safety decals below are on your rider and mower.

If any of these decals are lost or damaged, replace them at once. See your local dealer for replacements.

These labels are easily applied and will act as a constant visual reminder to you, and others who may use the equipment, to follow the safety instructions necessary for safe, effective operation.

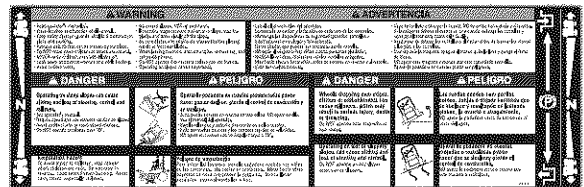
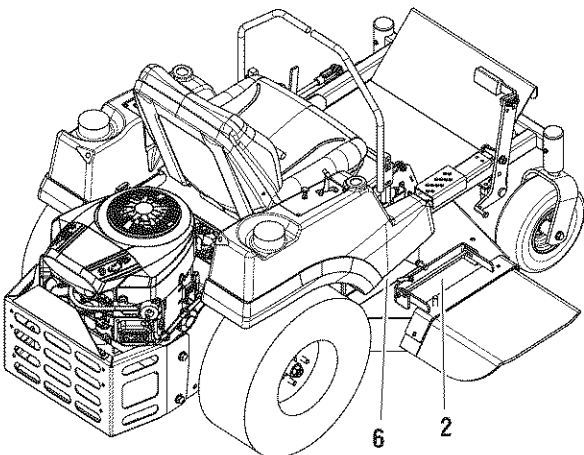
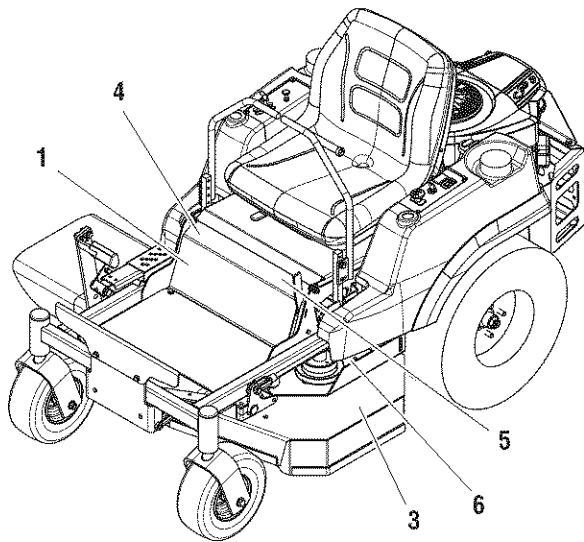

1



2



3



4



5

6

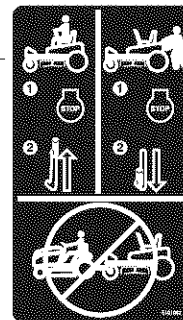



Safety Interlock System

This unit is equipped with safety interlock switches. These safety systems are present for your safety, do not attempt to bypass safety switches, and never tamper with safety devices. Check their operation regularly.

Operational SAFETY Checks

Test 1 — Engine should NOT crank if:

- PTO switch is engaged, OR
- Parking brake is not engaged, OR
- Ground speed control levers are not in the NEUTRAL position.

Test 2 — Engine SHOULD crank if:

- PTO switch is NOT engaged, AND
- Parking brake is engaged, AND
- Ground speed control levers are locked in the NEUTRAL position.

Test 3 — Engine should SHUT OFF if:

- Operator rises off seat with PTO engaged, OR
- Operator rises off seat with parking brake disengaged.
- Operator moves ground speed control levers out of their neutral positions before disengaging parking brake.

Test 4 — Blade Brake Check

Mower blades and mower drive belt should come to a complete stop within seven (7) seconds after electric PTO switch is turned off (or operator rises off seat). If mower drive belt does not stop within seven (7) seconds, see your dealer.

NOTE: Once the engine has stopped, PTO switch must be turned off, parking brake must be engaged, and the motion control handles must be locked in the NEUTRAL position after the operator returns to the seat in order to start the engine.

WARNING

If the unit does not pass a safety test, do not operate it. See your authorized dealer. Under no circumstance should you attempt to defeat the purpose of the safety interlock system.

Safety Icons

The alert symbol is used to identify safety information about hazards that can result in personal injury. A signal word (DANGER, WARNING, or CAUTION) is used with the alert symbol to indicate the likelihood and the potential severity of the injury. In addition, a hazard icon may be used to represent the type of hazard. An explanation of hazard levels and icons are as follows:

DANGER

This indicates a hazard which, if not avoided, will result in serious injury or death.

WARNING

This indicates a hazard which, if not avoided, could result in serial injury or death.

CAUTION

This indicates a hazard which, if not avoided, might result in minor or moderate injury.

CAUTION or NOTICE

These messages presented without the alert symbol indicate a situation where the unit or property could be damaged.

North American Safety Icons

Hazard	Safety Icon	Hazard	Safety Icon
Alert		Amputation Foot in Blade	
Toxic Fumes		Thrown Objects	
Read the Manual		Maintain a Safe Distance	
Open Flame Hazard		Keep Children Away	
Fire Hazard		Hot Surface	
Amputation Rotating Parts		Wear Protective Gear	
Amputation Hand in Blade		Pinch Point	
Rollover Hazard		Overhead Obstacles	

Features and Controls

Identification Numbers

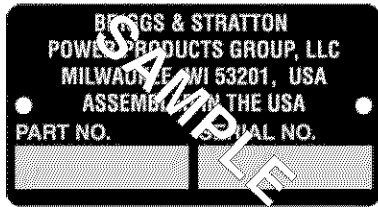

When contacting your authorized dealer for replacement parts, service, or information you **MUST** have these numbers.

Record your part number, serial number and engine serial numbers in the space provided on the inside front cover for easy access. These numbers can be found in the locations shown in Figure 1.

NOTE: For location of engine identification numbers, refer to the engine owner's manual.

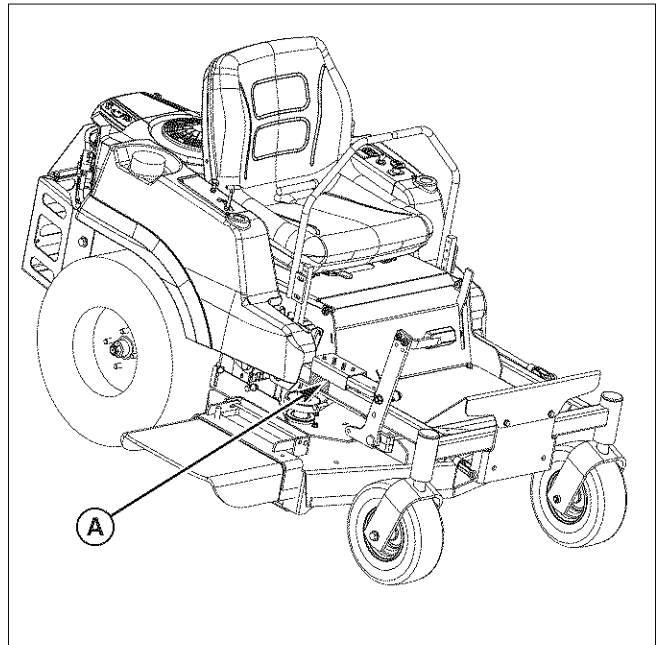

Figure 1. Identification Numbers
A. Identification Tag

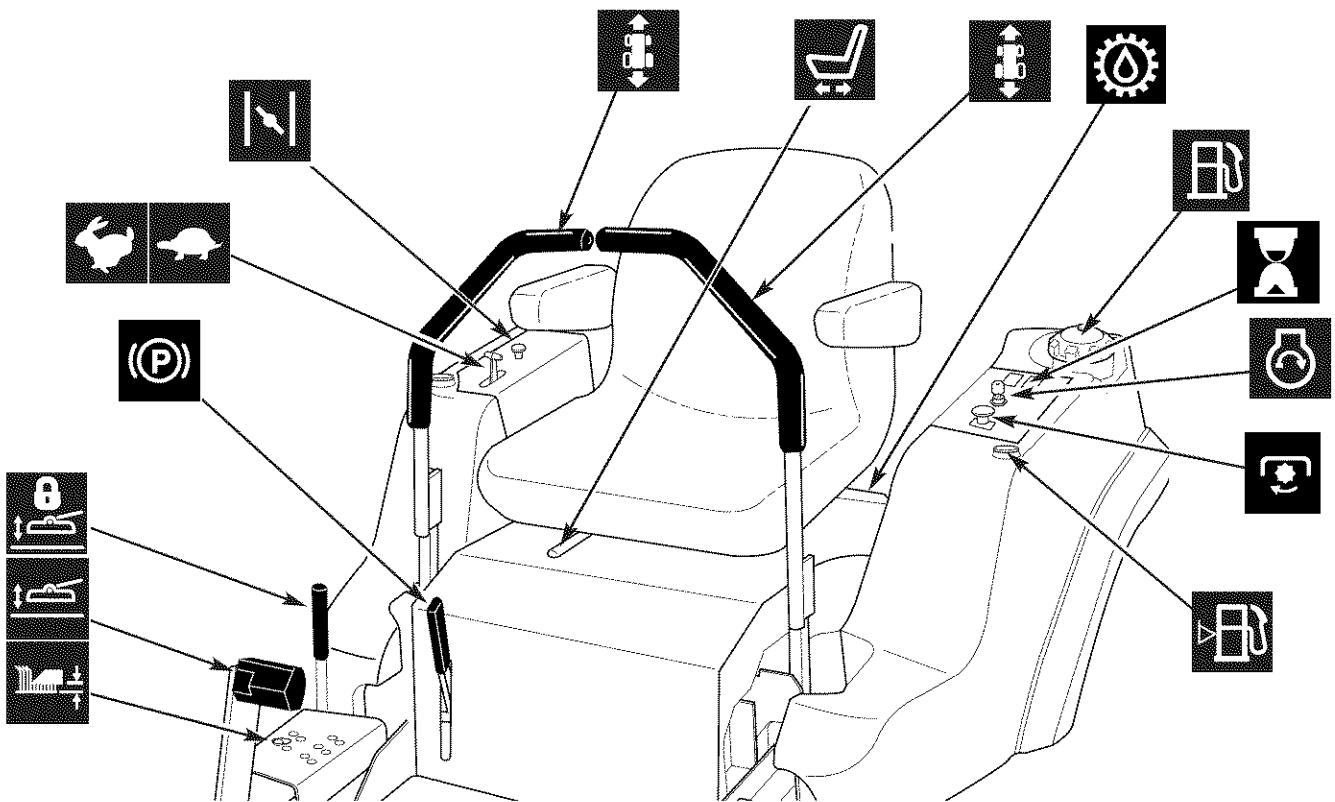

Figure 2. Control Locations

Controls

Control Functions

The information below briefly describes the function of individual controls. Starting, stopping, driving, and moving require the combined use of several controls applied in specific sequences. To learn what combination and sequence of controls to use for various tasks see the OPERATION section.

Ground Speed Control Levers

These levers control the ground speed of the rider. The left lever controls the left rear drive wheel and the right lever controls the right rear drive wheel.

Moving a lever forward increases the FORWARD speed of the associated wheel, and pulling back on a lever increases the REVERSE speed.

Note: The further a lever is moved away from the neutral position the faster the drive wheel will turn.



See the Operation section for proper steering instructions.

Seat Adjustment Lever

The seat can be adjusted forward and back. Move the lever towards the left, position the seat as desired, and release the lever to lock the seat in position.

Ignition Switch

The ignition switch starts and stops the engine, it has three positions:

-  OFF Stops the engine and shuts off the electrical system.
-  RUN Allows the engine to run and powers the electrical system.
-  START Cranks the engine for starting.

NOTE: Never leave the ignition switch in the RUN position with the engine stopped—this drains the battery.

Parking Brake

 DISENGAGE Releases the parking brake.

 ENGAGE Locks the parking brake.

Pull the parking brake lever up to engage the parking brake. Push the lever down to disengage the parking brake. *NOTE: To start the unit the parking brake must be engaged.*

PTO (Power Take Off) Switch

The PTO switch engages and disengages the mower. Pull UP on the switch to engage, and push DOWN to disengage.

Deck Lift Pedal, Cutting Height Adjustment Pin & Deck Lift Lock Lever

These control the cutting height of the mower deck. Depress the pedal until it locks into the 4-1/2" (11,47 cm) position. Place the adjustment pin in the desired cutting height and release the lift lock lever.

Throttle Control

The throttle controls engine speed. Move the throttle forward to increase engine speed and back to decrease engine speed. Always operate at FULL throttle.

Choke

Close the choke for cold starting. Open the choke once the engine starts. A warm engine may not require choking. Pull the knob UP to close the choke. Push to knob DOWN to open the choke.

Hour Meter / Maintenance Reminder

Measures the time of the PTO being engaged. The hour meter measures the number of hours the PTO has been engaged. The hour meter will flash an initial oil change indicator at 5 hours, and a lubrication reminder every 50 hours. These reminders display for approximately two hours and will automatically reset themselves.

Note: The hour meter will register the passage of time only when the PTO is engaged. The hour meter has a self contained power source so the total hours are always visible.

Fuel Tank Cap

To remove the cap, turn counterclockwise.

Fuel Level Gauge

Displays the fuel level in the tank.

Transmission Oil Fill

This unit is equipped with two transmission oil reservoirs. The transmission oil reservoirs are located beneath the operator's seat and in front of the engine. Transmission oil is added through the transmission oil reservoirs. It also serves as extra holding capacity as the transmissions heat up and the oil expands. See CHECK TRANSMISSION OIL LEVEL for oil level check and fill procedures.

Operation

General Operating Safety

Before first time operation:

- Be sure to read all information in the Safety and Operation sections before attempting to operate this tractor and mower.
- Become familiar with all of the controls and how to stop the unit.
- Drive in an open area without mowing to become accustomed to the unit.

⚠ WARNING

Never allow passengers to ride on the unit.

Before leaving the operator's position for any reason, engage the parking brake, disengage the PTO, stop the engine and remove the key.

To reduce fire hazard, keep the engine, tractor and mower free of grass, leaves and excess grease. Do not stop or park tractor over dry leaves, grass or combustible materials.

Gasoline is highly flammable and must be handled with care. Never fill the tank when the engine is still hot from recent operation. Do not allow open flame, smoking or matches in the area. Avoid over-filling and wipe up any spills.

⚠ WARNING

Do not load this zero-turn rider on a trailer or truck using two separate ramps. Only use a single ramp that is at least one foot wider than the width of the rear wheels of this rider. This rider has a zero turning radius and the rear wheels could fall off the ramps, or the rider could tip over injuring the operator or bystanders.

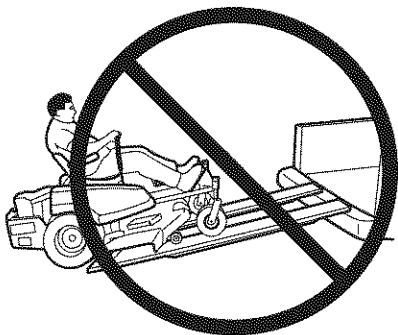

⚠ WARNING

Never operate on slopes greater than (15°) which is a rise of 5.4 feet (1,6 m) vertically in 20 feet (607 cm) horizontally.

Select slow ground speed before driving onto a slope. Use extra caution when operating on slopes with a rear-mounted grass catcher.

Mow across the face of slopes, not up and down, use caution when changing directions and **DO NOT START OR STOP ON SLOPE.**

Checks Before Starting

- Check that crankcase is filled to full mark on the engine oil dipstick (A, Figure 3). See the engine Operator's Manual for instructions and oil recommendations.
- Fill the fuel tanks with fresh fuel. Refer to engine manual for fuel recommendations.
- Make sure all nuts, bolts, screws and pins are in place and tight.
- Make sure the fuel selector valve (B) is in the "ON" position.
- Check the tire pressures. See *Check Tire Pressures*.
- Adjust the seat position, and make certain you can reach all controls from operator's position. See *Seat Adjustment*.
- Adjust the height of the mower deck to the desired position. See *Mowing Height Adjustment*.

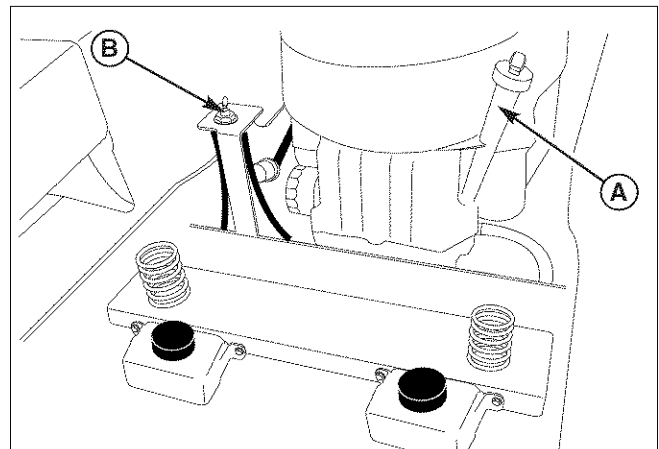

Figure 3. Checks Before Starting
 A. Engine Oil Dipstick
 B. Fuel Valve Selector

Check Tire Pressures

Tire pressure should be checked periodically, and maintained at the levels shown in the chart. Note that these pressures may differ slightly from the "Max Inflation" stamped on the side-wall of the tires. The pressures shown provide proper traction, improve cut quality, and extend tire life.

Tire	Pressure
Front	40 psi (2,76 bar)
Rear	15 psi (1,03 bar)

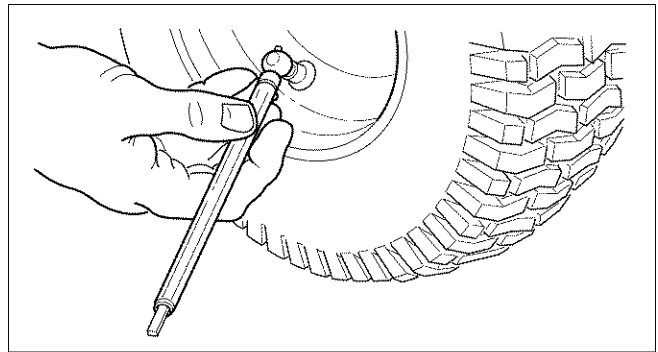

Figure 4. Checking Tire Pressure

Seat Adjustment

See Figure 5. The seat can be adjusted forward and backward. Move the lever towards the left, position the seat as desired, and release the lever to lock the seat into position.

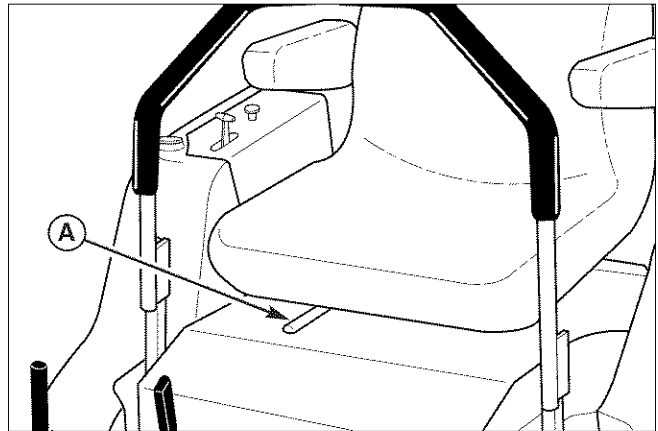

Figure 5. Seat Adjustment
A. Seat Adjustment Lever

Mowing Height Adjustment

The cutting height adjustment pin (A, Figure 6) controls the mower cutting height. The cutting height is adjustable between 1-1/2" (3,37 cm) and 4-1/2" (11,47 cm) in 1/4" (0,64 cm) increments.

1. Depress the deck lift foot pedal (B) until it locks into the 4-1/2" (11,47 cm) position.
2. Place the cutting height adjustment pin in the desired cutting height.
3. Depress the deck lift foot pedal then push the lock lever (C) toward the right to release the lock.
4. Release the deck lift foot pedal until it comes to rest against the cutting height adjustment pin.

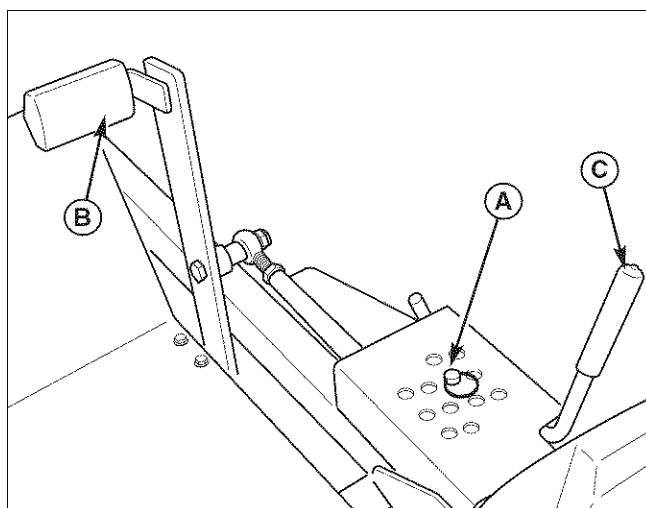

Figure 6. Mowing Height Adjustment

- A. Cutting Height Adjustment Pin
- B. Deck Lift Foot Pedal
- C. Deck Lift Lock lever

Foot Pedal Adjustment

The deck lift foot pedal can be adjusted to accommodate the operator's height for optimal comfort.

To adjust pedal position:

1. Remove the foot pedal (A, Figure 7) from the pedal mount tab (B).
2. Remove the pedal mount hardware (C) and rotate the tab 180 degrees.
3. Reinstall the pedal mount hardware and tighten securely.
4. Reinstall the foot pedal on the pedal mount tab in the proper orientation as shown in Figure 7.

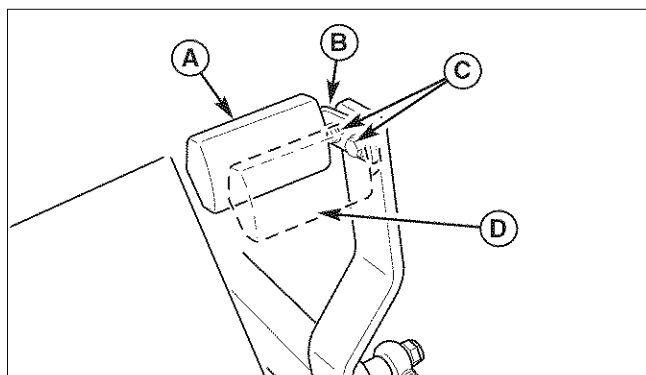

Figure 7. Foot Pedal Adjustment

- A. Deck Lift Foot Pedal
- B. Pedal Mount Tab
- C. Pedal Mount Hardware
- D. Optional Position

Starting the Engine

WARNING

If you do not understand how a specific control functions, or have not yet thoroughly read the **FEATURES & CONTROLS** section, do so now.

Do NOT attempt to operate the tractor without first becoming familiar with the location and function of **ALL** controls.

1. While sitting in the operator's seat, engage the parking brake by pulling the parking brake lever up, make sure the PTO switch is disengaged (pressed down fully) and the ground speed control levers are locked in the NEUTRAL position.
2. **NOTE: A warm engine may not require choking.** Set the engine throttle control to FULL throttle position. Then fully close the choke by pulling the knob OUT fully.
3. Insert the key into the ignition switch and turn it to START.
4. After the engine starts, gradually open the choke (push knob down fully). Reduce to half throttle speed and allow to warm up.

Warm up the engine by running it for at least a minute before engaging the PTO switch or driving the rider.

5. **After warming the engine, ALWAYS operate the unit at FULL THROTTLE** when mowing.

In the event of an emergency the engine can be stopped by simply turning the ignition switch to STOP. Use this method only in emergency situations. For normal engine shut down follow the procedure given in **STOPPING THE RIDER.**

Stopping the Rider

1. Returning the ground speed control levers to the middle position will stop rider movement. Pivot the levers outward and lock them in NEUTRAL.
2. Disengage the PTO by pushing down on the PTO switch.
3. Engage the parking brake by pulling the handle up until it locks into position.
4. Move the throttle control to mid-throttle position and turn the ignition key to OFF. Remove the key.

Pushing the Rider By Hand

NOTICE

DO NOT TOW RIDER

Towing the units will cause transmission damage. Do not use another vehicle to push or pull this unit.

1. Disengage the PTO, engage the parking brake, turn the ignition OFF, and remove the key.
2. Locate the transmission release levers (A, Figure 8) located underneath the front of the fuel tanks.
3. Pull both transmission release levers back and down so that they lock in the disengaged (free-wheel position) (C).
4. Disengage the parking brake.
The tractor can now be pushed by hand.
5. After moving the tractor, re-engage the transmissions by pulling the transmission release levers up and pushing them forward to the engaged (drive) position (B).

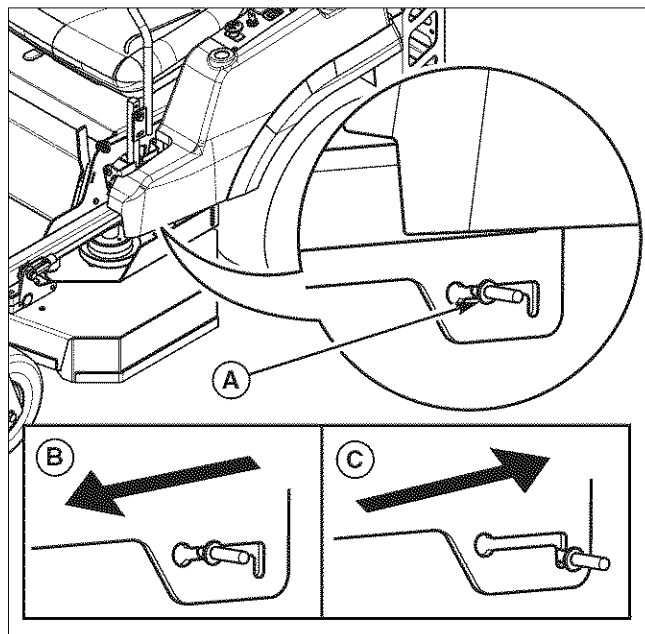

Figure 8. Transmission Release Levers (LH shown)

- A. Transmission Release Lever
- B. Engaged Position (Drive Position)
- C. Disengaged Position (Free-wheel Position)

Zero Turn Driving Practice

The lever controls of the Zero Turn rider are responsive, and learning to gain a smooth and efficient control of the rider's forward, reverse, and turning movements will take some practice.

Spending some time going through the maneuvers shown and becoming familiar with how the unit accelerates, travels, and steers — before you begin mowing — is absolutely essential to getting the most out of the Zero Turn rider.

Locate a smooth, flat area of your lawn — one with plenty of room to maneuver. (Clear the area of objects, people and animals before you begin.) Operate the unit at mid-throttle during this practice session (ALWAYS operate at full throttle when mowing), and turn slowly to prevent tire slippage and damage to your lawn.

We suggest you begin with the Smooth Travel procedure to the right, and then advance through the forward, reverse, and turning maneuvers.

You must release the parking brake prior to moving the ground speed control levers inward.

Smooth Travel

The lever controls of the Zero Turn rider are responsive.

The BEST method of handling the ground speed control levers is in three steps — as shown in Figure 9.

FIRST place your hands onto the levers as shown.

SECOND, to go forward gradually push the levers forward with your palms.

THIRD, to speed up move the levers farther forward. To slow down smoothly, slowly move the levers toward neutral.

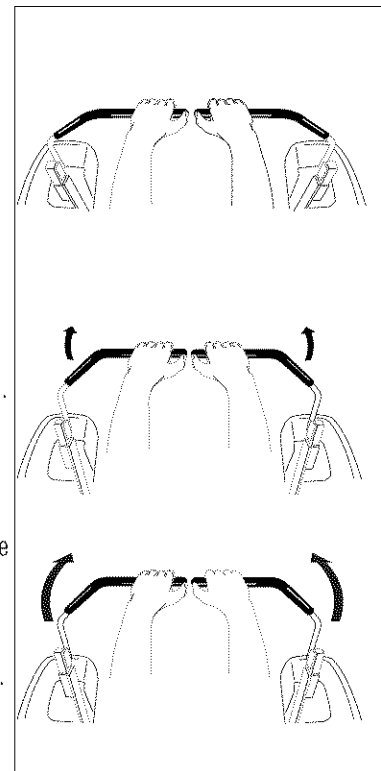

Figure 9. Move Control Levers Gradually

Forward Travel Practice

Gradually move both ground speed control levers — evenly FORWARD from neutral. Slow down and repeat.

NOTE: Straight forward travel takes practice. If necessary, top speed can be balance-adjusted — see the Speed Balancing Adjustment in the Adjustments section near the back of this manual.

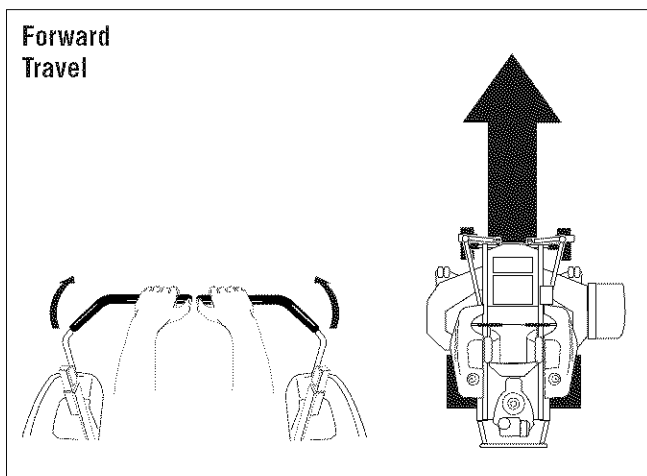

Figure 10. Forward Travel

Reverse Travel Practice

LOOK DOWN & BEHIND, then gradually move both ground speed control levers evenly BACK from neutral. Slow down and repeat.

NOTE: Practice backing up for several minutes before attempting to do so near objects. The rider turns sharply in reverse as well as forward, and backing up straight takes practice.

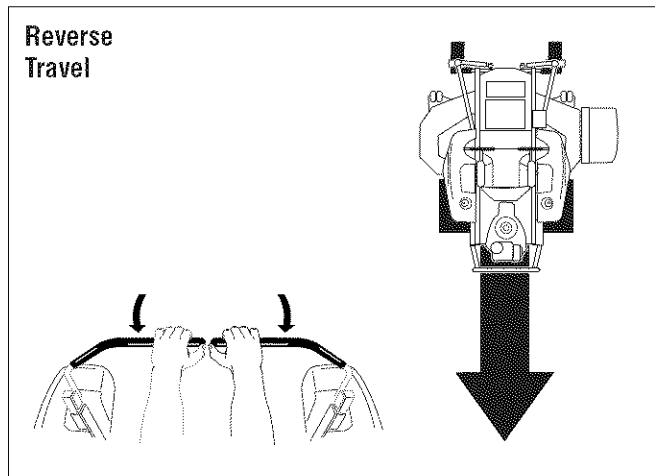

Figure 11. Reverse Travel

Practice Turning Around a Corner

While traveling forward allow one lever to gradually return back toward neutral. Repeat several times.

NOTE: To prevent pivoting directly on the tire tread, it is best to keep both wheels going at least slightly forward.

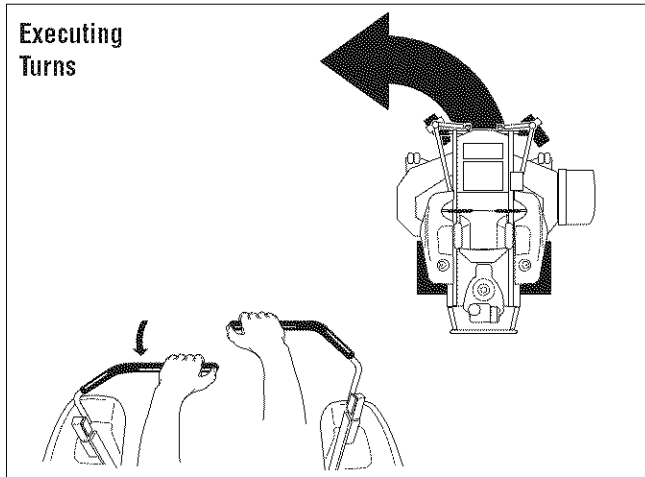

Figure 12. Turning Around a Corner

Practice Turning In Place

To turn in place, “Zero Turn,” gradually move one ground speed control lever forward from neutral and one lever back from neutral simultaneously. Repeat several times.

NOTE: Changing the amount each lever is pulled—forward or back, changes the “pivot point” you turn on.

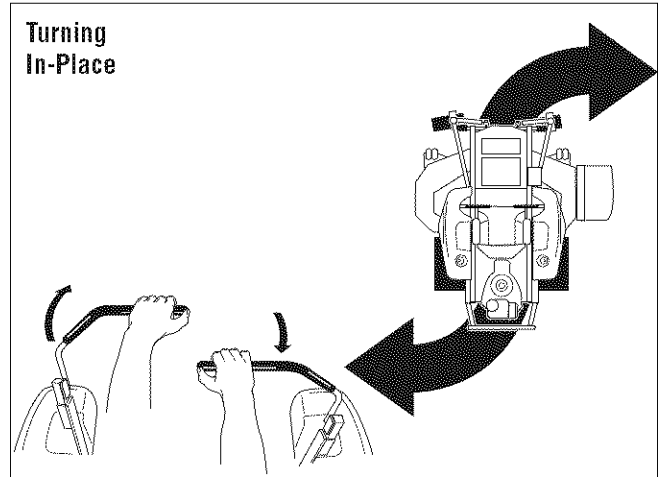

Figure 13. Turning in Place

Executing an End-Of-Row Zero Turn

Your Zero Turn Rider’s unique ability to turn in place allows you to turn around at the end of a cutting row rather than having to stop and Y-turn before starting a new row.

For example, to execute a left end-of row zero turn:

1. Slow down at the end of the row.
2. Move the RIGHT ground speed control lever forward slightly while moving the LEFT ground speed control lever back to center and then slightly back from center.
3. Begin mowing forward again.

This technique turns the rider LEFT and slightly overlaps the row just cut —eliminating the need to back up and re-cut missed grass.

As you become more familiar and experienced with operating the Zero Turn rider, you will learn more maneuvers that will make your mowing time easier and more enjoyable.

Remember, the more you practice, the better your control of the Zero Turn will be!

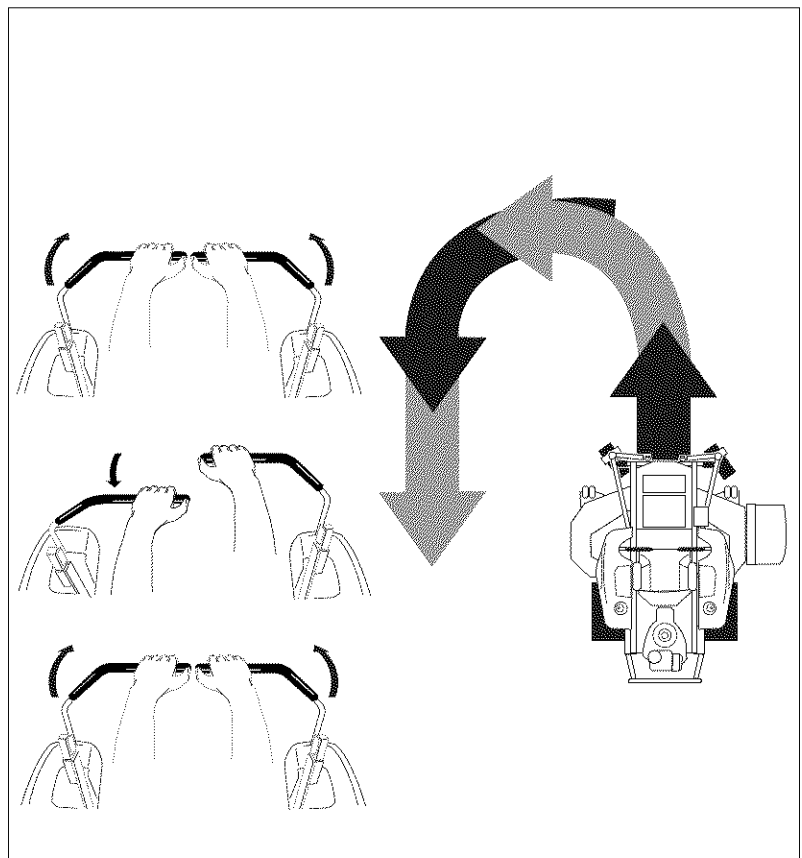

Figure 14. Executing an End-Of-Row Turn

Mowing

1. Engage the parking brake. Make sure the PTO switch is disengaged, the ground speed control levers are locked in the NEUTRAL position and the operator is on the seat.
2. Start the engine (see *Starting The Engine*).
3. Set the mower cutting height (see *Mowing Height Adjustment*).
4. Set the throttle to FULL.
5. Engage the PTO by pulling up on the PTO switch.
6. Begin mowing. See *Mowing Recommendations* for tips on mowing patterns, lawn care, and trouble shooting information.
7. When finished, shut off the PTO by pushing the PTO switch down completely.
8. Stop the engine (see *Stopping The Rider and Engine*).

Mowing Recommendations

Several factors can affect how well your machine cuts grass. Following proper mowing recommendations can improve the performance and life of your machine.

Height of Grass

Often cutting height is a matter of personal preference. Typically, you should mow the grass when it is between three and five inches high. The proper cutting height range for a specific lawn will depend upon several factors, including the type of grass, the amount of rainfall, the prevailing temperature, and the lawn's overall condition.

Cutting the grass too short causes weak, thin grass plants, which are easily damaged by dry periods and pests. Cutting too short is often more damaging than allowing the grass to be slightly higher.

Letting grass grow a bit longer—especially when it is hot and dry—reduces heat build-up, preserves needed moisture and protects the grass from heat damage and other problems. However, allowing grass to grow too high can cause thin turf and additional problems.

Cutting off too much at one time shocks the plant's growth system and weakens the grass plants. **A good rule of thumb is the 1/3 rule: to cut no more than one third of the grass height, and never more than 1 inch at a time.**

The amount of grass you are able to cut in one pass is also effected by the type of mowing system you are using (for example, broadcasting with side discharge decks can process a much larger volume of grass than mulching does).

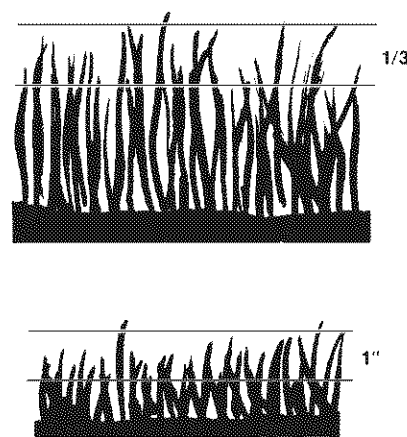

Figure 15. Proper Cutting Height

Tall Grass Requires Incremental Cutting

For extremely tall grass, set the cutting height at maximum for the first pass, and then reset it to the desired height and mow a second or third time.

Don't cover the grass surface with a heavy layer of clippings. Consider using a grass collection system and starting a compost pile.

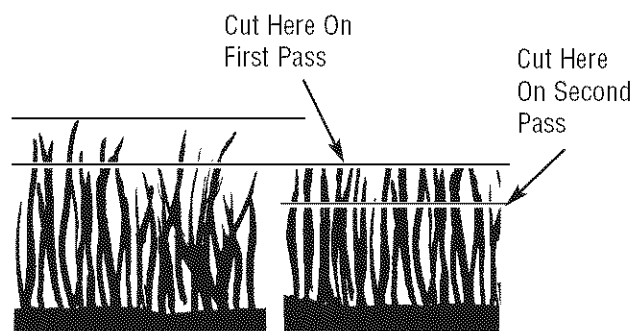

Figure 16. Incremental Cutting

When and How Often to Mow

The time of day and condition of the grass greatly affect the results you'll get when mowing. For the best results, follow these guidelines:

1. Mow when the grass is between three and five inches high.
2. Mow with sharp blades. Short clippings of grass one inch or shorter decompose more quickly than longer blades. Sharp mower blades cut grass cleanly and efficiently, preventing frayed edges which harm the grass.
3. Mow at time of day when the grass is cool and dry. Late afternoon or early evening often provide these ideal mowing conditions.
4. Avoid mowing after rain or even heavy dew, and never mulch when the grass is wet (moist grass does not mulch well, and clumps beneath the mower deck).

Mowing Patterns

Always start mowing on a smooth, level area.

The size and type of area to be mowed will determine the best mowing pattern to use. Obstructions such as trees, fences and buildings, and conditions such as slopes and grades must also be considered.

1. Cut long straight strips overlapping slightly.
2. Where possible, change patterns occasionally to eliminate matting, graining or a corrugated appearance.
3. For a truly professional cut, mow across the lawn in one direction, then recut the lawn by mowing perpendicular to the previous cut.

Note: Always operate the engine at full throttle when mowing.

If you hear the engine slowing down, you are mowing too fast—using a slower ground speed will improve the cutting efficiency of the blades and prevents many common cutting problems. Use an appropriate ground speed for the thickness and height of the grass you are cutting (3rd gear or slower for manual gear models). If you hear the engine slowing down you are mowing too fast, use a slower ground speed.

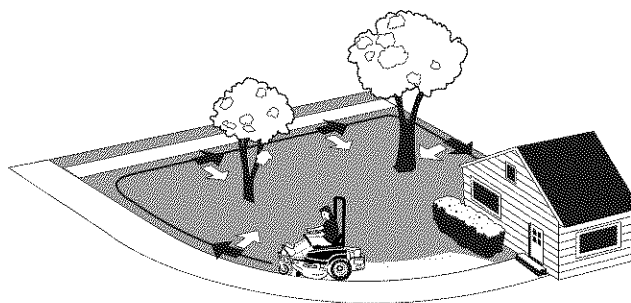

Where possible, make one or two passes around the outside of the area discharging the grass INTO the lawn to keep the cut grass off fences and walks.

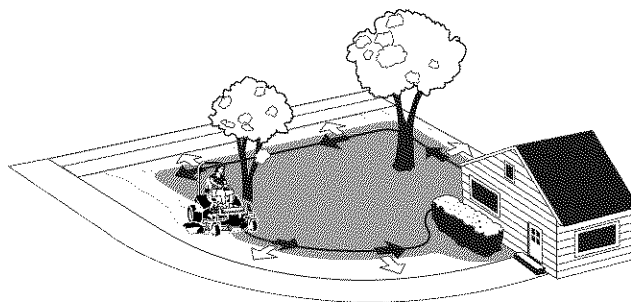

The remainder of the mowing should be done in the opposite direction so that the clippings are dispersed OUT onto the area of lawn previously cut.

Mowing Methods

Proper Broadcast Mowing

Broadcasting, or side-discharging, disperses fine clippings evenly over the entire lawn. Many golf courses use this method. Your mower has a deep dish deck to allow freer circulation of clippings so they are broadcast evenly over the lawn.

Engine Speed & Ground Speed for Broadcasting

Always operate the engine at full throttle when mowing. If you hear the engine slowing down, you are mowing too fast—using a slower ground speed will improve the cutting efficiency of the blades and prevents many common cutting problems.

ALWAYS use an appropriate ground speed for the thickness and height of the grass you are cutting (3rd gear or slower for manual gear models). If you hear the engine slowing down you are mowing too fast, use a slower ground speed.

How Much Grass to Cut Off When Broadcasting

Mow when the grass is 3-5 inches long. Do not cut the grass shorter than 2 to 2-1/2 inches. Do not cut off more than 1 inch of grass in a single pass.

Proper Mulching

Mulching consists of a mower deck which cuts and recuts clippings into tiny particles and which then blows them down INTO the lawn. These tiny particles decompose rapidly into by-products your lawn can use. UNDER PROPER CONDITIONS, your mulching mower will virtually eliminate noticeable clippings on the lawn surface.

NOTE: When mulching under heavy cutting conditions, a rumbling sound may be present and is normal.

Mulching Requires EXCELLENT Mowing Conditions

Mulching mowers cannot function properly if the grass is wet, or if the grass is simply too high to cut. Even more than normal mowing, mulching requires that the grass be dry and the appropriate amount is cut.

Do not use the mower as a mulching mower during the first two or three mowings in the spring. The long grass blades, quick growth, and often wetter conditions are more suitable for broadcasting (side-discharging) or grass bagging operation.

Engine Speed & Ground Speed for Mulching

Use full engine throttle matched with a slow ground speed so that clippings will be finely cut. Ground speed while mulching should be HALF of the speed that would be used when broadcasting (side discharging) under similar conditions. Since mulching requires more horsepower than broadcasting, using a slower ground speed is vitally important for proper mulching operation.

How Much Grass to Mulch

The best mulching action typically results from cutting only the top 1/2 inch to 3/4 inch of grass blade. This provides short clippings which decompose properly (much more quickly than longer clippings). The ideal cutting height will vary with climate, time of year, and quality of your lawn. We recommend that you experiment with both the cutting height and ground speed until you achieve the best cut. Start with a high cutting height and using progressively lower settings until you find a cutting height that is matched to your mowing conditions and preferences.

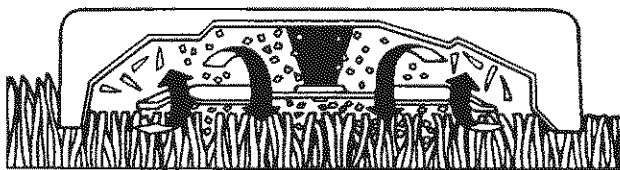

Figure 17. Mulching Action

Attaching A Trailer

The maximum weight of a towed trailer should be less than 200 lbs (91kg). Secure the trailer with an appropriately sized clevis pin (A, Figure 18) and clip (B).

Excessive towed loads can cause loss of traction and loss of control on slopes. Reduce towed weight when operating on slopes. The surface being driven on greatly impacts traction and stability. Wet or slippery surfaces can greatly reduce traction and the ability to stop or turn. Carefully evaluate the surface conditions before operating the unit and trailer, and never operate on slopes greater than 10°. See SLOPE OPERATION and TOWED EQUIPMENT in the safety section of this manual for additional safety information.

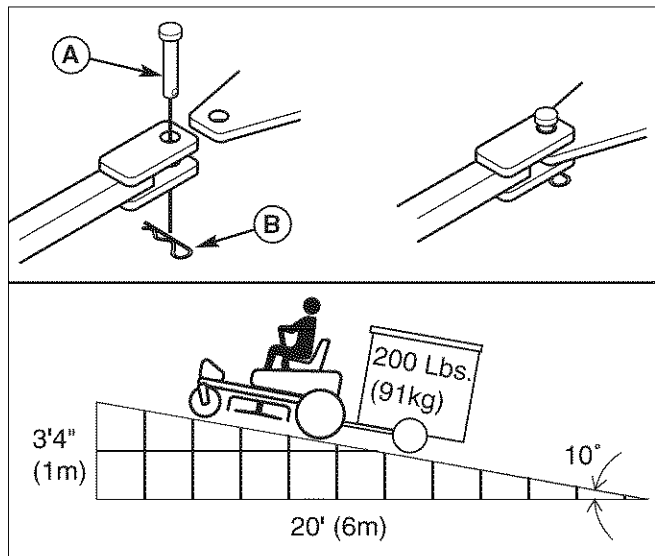

Figure 18. Trailer Weight Recommendations
 A. Clevis Pin
 B. Clip

Regular Maintenance

Regular Maintenance

Maintenance Schedule

The following schedule should be followed for normal care of your rider and mower. You will need to keep a record of your operating time. Determining operating time is easily accomplished by observing the elapsed time recorded by the hour meter.

Safety Items	Before Each Use	Every 5 Hours	Every 25 Hours	Every 100 Hours	Every 250 Hours	Spring & Fall
Check Safety Interlock System	•					•
Check Rider Brakes	•					•
Check Mower Blade Stopping Time				•		•
Rider Maintenance	Before Each Use	Every 5 Hours	Every 25 Hours	Every 100 Hours	Every 250 Hours	Spring & Fall
Check Rider / Mower for loose hardware	•	•				
Clean Deck & Check / Replace Mower Blades**			•			
Lubricate Rider & Mower **			•			
Clean Battery & Cables				•		
Check Tire Pressure			•			
Check Transmission Oil	•				•	
Change Transmission Oil Filter **					•	
Engine Maintenance	Before Each Use	Every 5 Hours	Every 25 Hours	Every 100 Hours	Every 250 Hours	Spring & Fall
Check Engine Oil Level	•					
Check / Clean Cooling Fins & Intake **			•			
Service Air Filter *						
Change Oil & Filter *						
Check / Replace Spark Plugs *						
Check / Replace Fuel Filter *						

* Refer to engine owner's manual. Change original engine oil after initial break-in period.

** More often in hot (over 85° F: 30° C) weather or dusty operating conditions.

Checking / Adding Fuel

To add fuel:

1. Remove the fuel cap.
2. Fill the tank to about 1-1/2" (3,81 cm) of the bottom of the filler neck. This will allow for fuel expansion.

NOTE: Do not overfill. Refer to your engine manual for specific fuel recommendations.

3. Install and hand tighten the fuel cap.

Fuel Filter

The fuel filter is located in the fuel line between the fuel tank and the carburetor, near the fuel pump. If filter is dirty or clogged, replace as follows:

1. Disconnect the negative battery cable.
2. Place a container below the filter to catch any spilled fuel.
3. Using pliers, open and slide the hose clamps from the fuel filter (D, Figure 19).
4. Remove the hoses from the fuel filter.
5. Install the new fuel filter in the proper flow direction in the fuel line.
6. Secure with the hose clamps.
7. Reconnect the negative battery cable when finished.

Change Oil & Filter

1. Warm engine by running for a few minutes. (Refer to the engine operator's manual for oil and filter replacement instructions.)
2. **Briggs & Stratton Models:** Locate the oil drain hose (A, Figure 19) on the left side of the engine and route the oil drain hose over the rear of the engine deck.
3. Place a small pan under the oil drain hose to catch the oil. Using the appropriate tools, remove the cap (B) from the oil drain hose (A) and drain the engine oil into the pan.
4. After draining, replace the cap and wipe up any spilled oil. Route the oil drain towards the front of the machine facing so the oil drain hose is retained during normal operation.
5. Place an absorbent shop cloth under the engine oil filter. Remove the engine oil filter and replace with a new one.
6. **Briggs & Stratton Models:** Remove the engine oil dipstick (F) that is located on the left side of the engine and refill with new oil (Refer to the engine operator's manual for oil recommendations.)
7. Remove the shop cloth and wipe up any spilled oil.

Engine Maintenance

Refer to the engine owner's manual for all engine maintenance procedures and recommendations.

⚠ WARNING

Gasoline is highly flammable and must be handled with care. Never fill the tank when the engine is still hot from recent operation. Do not allow open flame, smoking or matches in the area. Avoid over-filling and wipe up any spills.

Do not remove fuel filter when engine is hot, as spilled gasoline may ignite. **DO NOT** spread hose clamps further than necessary. Ensure clamps grip hoses firmly over filter after installation.

NOTICE

Do not use gasoline containing METHANOL, gasohol containing more than 10% ethanol, gasoline additives, premium gasoline, or white gas because engine/fuel system damage could result.

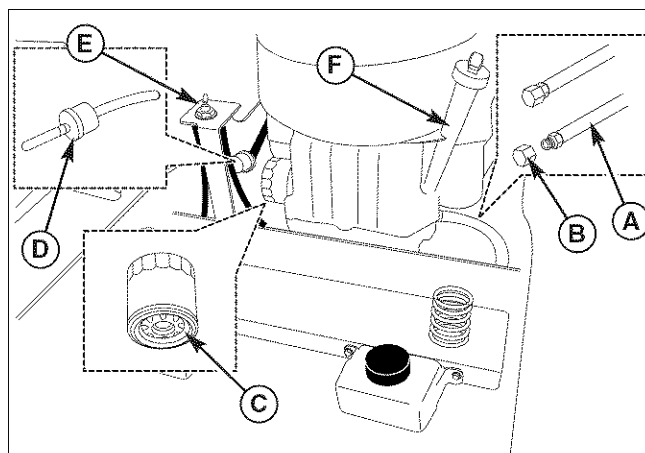

Figure 19. Engine Oil Drain (Briggs & Stratton shown)

- A. Oil Drain Hose
- B. Cap
- C. Oil Filter
- D. Fuel Filter
- E. Fuel Tank Selection Valve
- F. Oil Dipstick

Lubrication

Lubricate the unit at the locations shown in Figures 20 through 23 as well as the following lubrication points.

Grease:



- front caster wheel axles & yokes
- deck lift pivot blocks
- mower deck spindles
- mower deck idler arm

Use grease fittings when present. Disassemble parts to apply grease to moving parts when grease fittings are not installed.

Not all greases are compatible. Red Grease (p/n 5022285) is recommended, automotive-type high-temperature, lithium grease may be used when this is not available.

Oil:



- control handle pivots
- seat plate pivots
- deck lift pivots
- discharge chute hinge

Generally, all moving metal parts should be oiled where contact is made with other parts. Keep oil and grease off belts and pulleys. Remember to wipe fittings and surfaces clean both before and after lubrication.

Lubricating the Front Casters:

NOTE: Front casters should be lubricated annually.

1. Remove the 1/4-28 bolt (A, Figure 23) screwed into the front caster and install a 1/4-28 grease fitting.
2. Grease the front caster.
3. Remove the 1/4-28 grease fitting and reinstall the 1/4-28 bolt.
4. Repeat process for the other side of the machine.

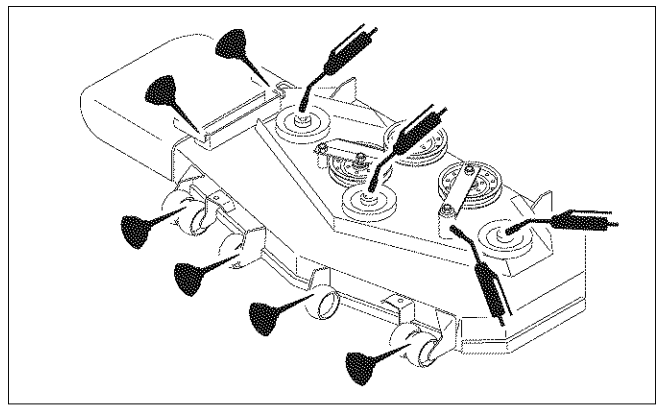

Figure 20. Deck Lubrication

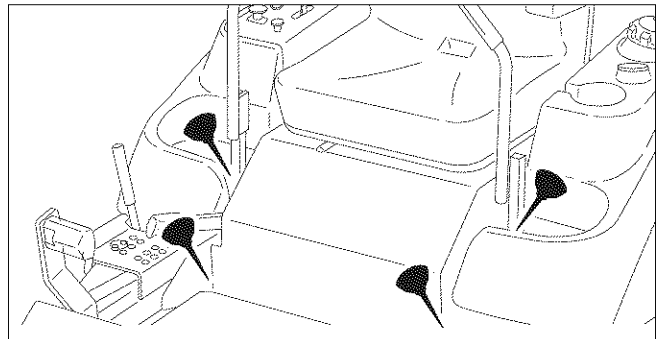

Figure 21. Control Handle Pivots & Seat Plate Pivots

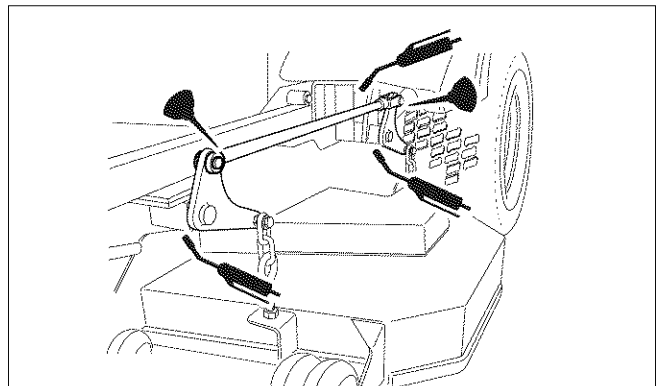

Figure 22. Deck Lift Linkage Pivots

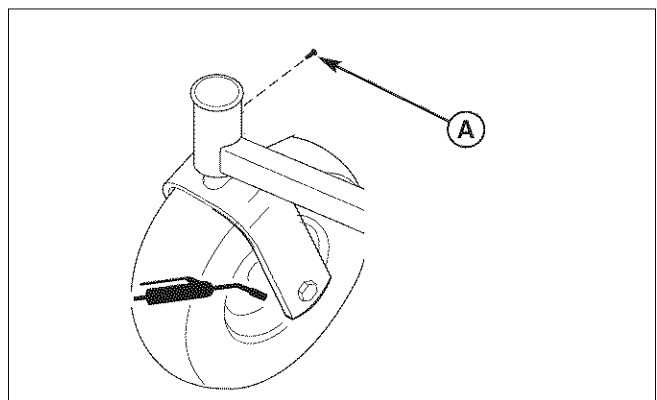

Figure 23. Front Caster & Wheel
A. 1/4-28 Bolt

Check / Fill Transmission Oil

Oil Type: 20W-50 conventional detergent motor oil.

1. Check the oil level when the unit is cold. Locate the transmission oil reservoirs (A, Figure 24) located on the seat support plate. The oil should be up to the "FULL COLD" mark (B). If the oil is below this level, proceed to step 2.
2. Before removing the reservoir caps, make sure the area around the reservoir cap and fill neck of the reservoir is free of dust, dirt, or other debris. Remove the reservoir cap.
3. Add oil up to the "FULL COLD" mark (B).
4. Reinstall the reservoir caps.

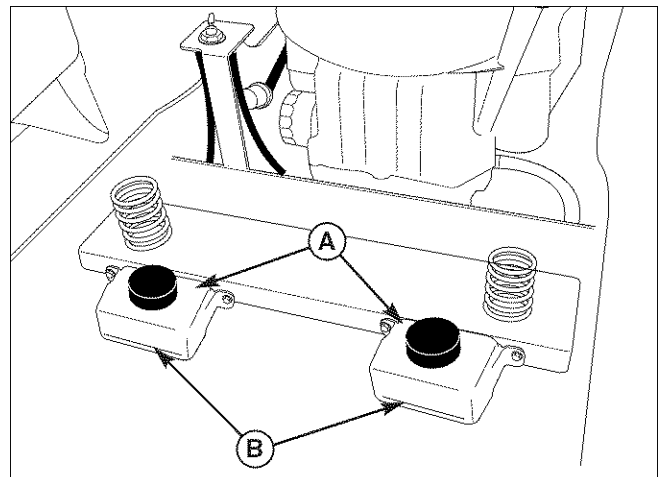

Figure 24. Checking Transmission Oil Level
A. Transmission Oil Reservoirs
B. "FULL COLD" mark

Transmission Oil Filter Change

Change Interval: Every 200 Hours

Replacement Filter Number: 5101026X1

1. Locate the transmission oil filters (A, Figure 25) underneath the rear of the machine on the transmissions.
2. Remove the three 1/4" filter guard screws (C) and the filter guard (B).
3. Clean the area around the filter base and remove the filter.
4. Apply a film of new oil to the gasket of the new replacement filter. After the oil has drained, thread the new filter onto the filter base until the gasket makes contact, then tighten 3/4 of a turn more.
5. Reinstall the filter guard with the three 1/4" filter guard screws
6. Using a hex bit swivel socket or a modified allen wrench remove the top port plug from the transmissions.
7. Remove the transmission reservoir cap and fill with oil until oil appears at the bottom of the transmission's top port (approximately 2 qts (1,89L).
8. Reinstall the top port plug and tighten to 15 ft lbs (20,38 Nm).
9. Continue to add oil to the transmission oil reservoirs until the oil level reaches the "FULL COLD" mark. Reinstall the oil reservoir cap.
10. Repeat this process for the other side of the machine.
11. Run the unit for several minutes and check the transmission oil level.

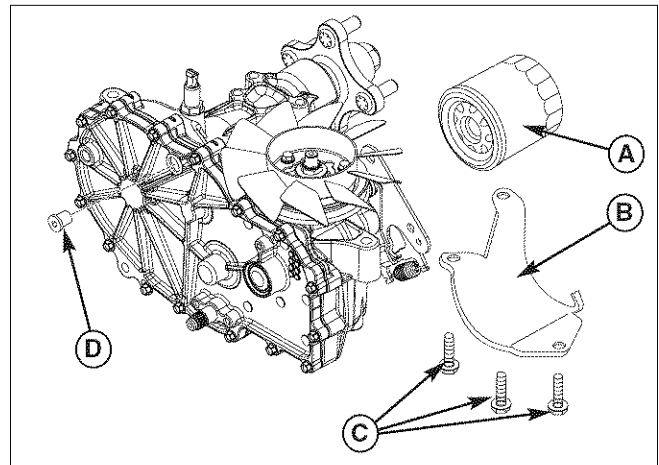

Figure 25. Transmission (Left Side Shown.)
A. Transmission Oil Filter
B. Filter Guard
C. 1/4" Filter Guard Screws
D. Top Port Plug

IMPORTANT NOTE: Use caution after changing the filter; air in the hydraulic system may affect the responsiveness of the ground speed control levers. Repeat step 11 until the air is out of the system.

Servicing The Mower Blades

Removing the Mower Blade

CAUTION

Avoid injury! Mower blades are sharp.

- Always wear gloves when handling mower blades or working near blades.

1. To remove the mower blade, use a 1" wrench on the flats of the spindle shaft and remove the mower blade mounting bolt with a 15/16" wrench (Figure 26).
2. If there are no flats on the spindle shaft, wedge a wooden block between the mower blade and the mower deck housing to keep the mower blade from turning.

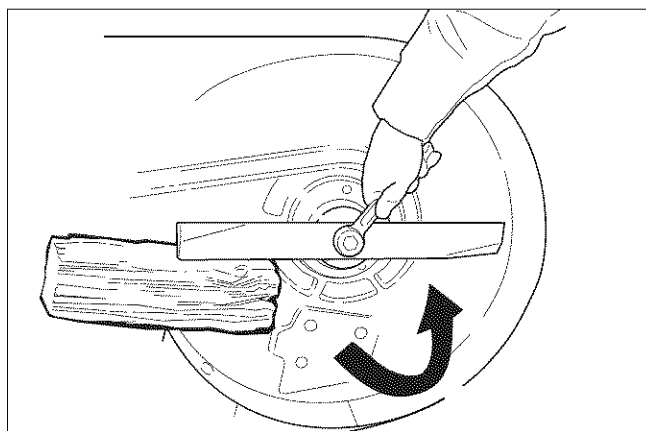

Figure 26. Loosening the Mower Blade for Removal

Inspecting the Mower Blades

DANGER

Avoid injury! A worn or damaged blade can break, and a piece of the mower blade could be thrown into the operator's or bystander's area, resulting in serious personal injury or death.

- Inspect the mower blade every 25 hours or at least once a year.

- If the mower blade hits a solid object, stop the engine immediately and inspect the mower blade.

- Never weld or straighten bent mower blades.

1. Remove the mower blade from the unit. *See Removing the Blade.*
2. Inspect the mower blade (Figures 27 & 28). **Discard the mower blade if it has any of the below conditions.**
 - A.) Has more than .5" (12,7 mm) of the mower blade metal removed from previous sharpening or wear (D, Figure 27).
 - B.) The air lifts are excessively eroded (B & C, Figure 28) and the notch (C) is .25" (6,35 mm) deep or greater.
 - C.) Mower blade is bent or broken.
3. If the cutting edges are not sharp or have nicks, sharpen the blades. *See Sharpening the Mower Blades.*

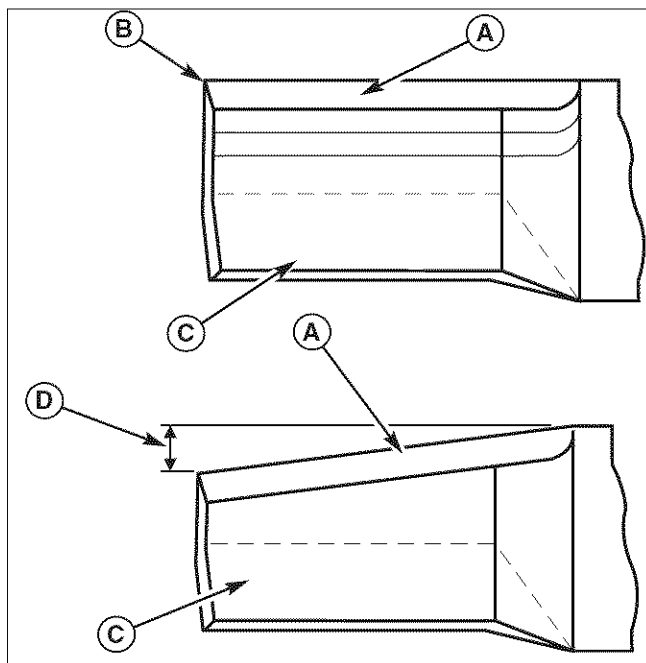

Figure 27. Inspecting the Mower Blade Tips

A. Mower Blade Cutting Edge

B. Square Corner

C. Air Lift

D. Wear Measurement - **DISCARD** Mower Blade If greater than .5" (12,7 mm)

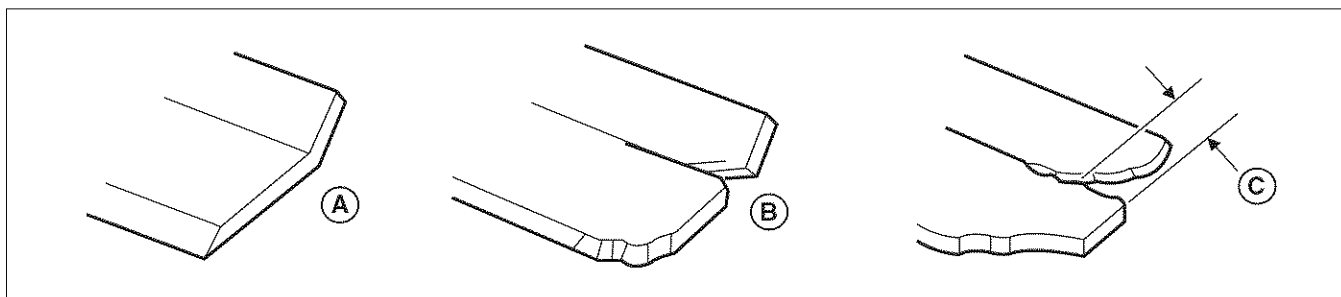

Figure 28. inspecting the Mower Blade Air Lifts

A. New Mower Blade

B. Mower Blade at Wear Limit (A notch begins to form)

C. Mower Blade in Dangerous Condition (Notch measures .25" (6,35 mm) or greater **DO NOT USE**. Replace with new mower blade.)

Sharpening the Mower Blade

⚠ CAUTION

Avoid injury! Mower blades are sharp.

- Always wear gloves when handling the mower blades.
- Always wear safety eye protection when grinding.

1. Sharpen the mower blades with grinder, hand file, or electric blade sharpener.
2. Sharpen the mower blade by removing an equal amount of material from each end of the mower blade.
3. Keep the original bevel (A, Figure 29) when grinding. DO NOT change the mower blade bevel.
4. The mower blade should have a maximum 1/64" (0,40 mm) cutting edge (B) or less.
5. Balance the mower blades before installing.

Balancing the Mower Blades

⚠ CAUTION

Avoid injury! Keep mower blades balanced.

- An unbalanced mower blade can create excessive vibration and damage the unit or cause mower blade failure.

1. Clean the mower blade to remove any dried grass or other debris.
2. See Figure 30. Put the mower blade on a nail in a vise and turn the mower blade to the horizontal position.
3. Check the balance of the mower blade. If either end of the mower blade moves downward, sharpen the heavy end until the mower blade is balanced. *See Sharpening the Mower Blades* for proper sharpening instructions.
4. Repeat the process until the mower blade remains in the horizontal position.

Reinstalling the Mower Blades

1. Reinstall each mower blade with the air lifts pointing up towards the mower deck as shown in Figure 31.
48" Models: Secure with the mower blade mounting bolt and flat washer (A & B, Figure 31) and torque to 70 ft. lbs (94 Nm).
2. If there are no flats on the spindle shaft, wedge a wooden block between the mower blade and the mower deck housing to keep the mower blade from turning.

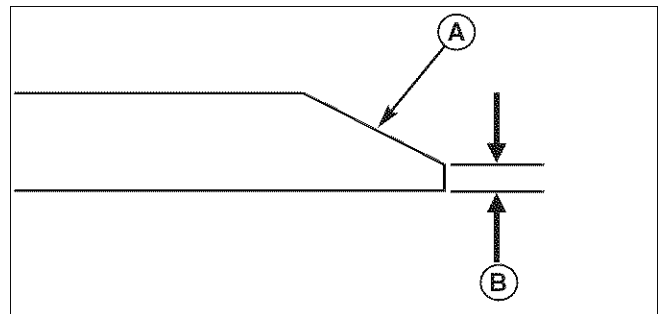

Figure 29. Sharpening the Mower Blade
A. Mower Blade Bevel
B. Mower Blade Cutting Edge

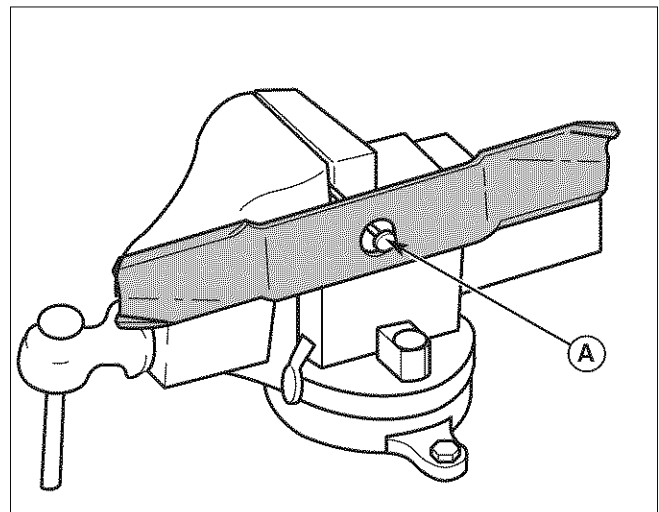

Figure 30. Balancing the Mower Blade
A. Nail

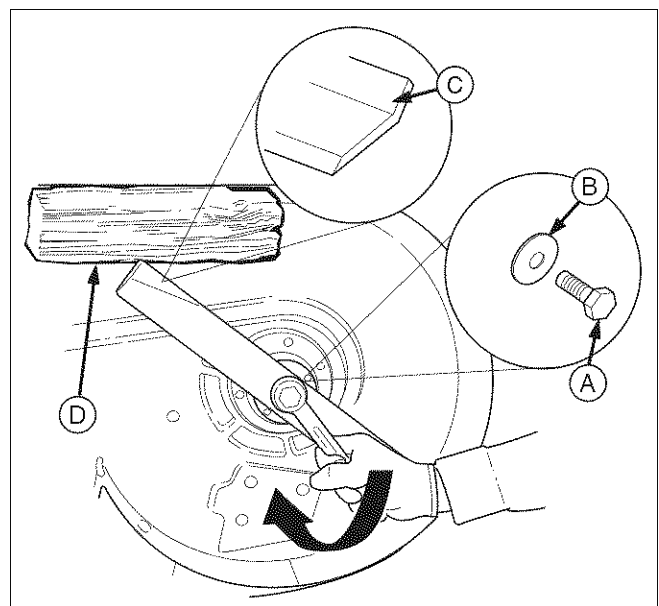

Figure 31. Tightening the Mower Blade for Installation
A. Mower Blade Mounting Bolt
B. Flat Washer
C. Mower Blade Air Lift (Points Up For Installation)
D. 4 X 4 Wooden Block

Ground Speed Control Lever Adjustment

The control levers can be adjusted in three ways. The alignment of the control levers, the placement of the levers (how close the ends are to one another) and the height of the levers can be adjusted.

To Adjust the Handle Alignment

Loosen the mount bolts (A, Figure 32) and pivot the lever(s) (B) to align with each other.

To Adjust the Handle Placement

Loosen the jam nuts and adjust the placement bolt (C, Figure 33) in or out to properly adjust the lever end spacing.

To Adjust the Handle Height

Remove the mounting hardware and reposition the handle either up or down from its original position. You will need to readjust the handle alignment as described above.

Speed Balancing Adjustment

If the rider veers to the right or left when the ground speed control levers are in the maximum forward position, the top speed of each of these levers can be balanced by turning the adjustment bolt(s) (A, Figure 33). Only adjust the speed of the wheel that is traveling faster.

To Reduce the Speed of the Faster Wheel

1. Loosen the securing nut.
2. Turn the top speed adjustment bolt COUNTER-CLOCKWISE to reduce the speed.
3. Retighten the securing nut when adjustment is complete.

WARNING

DO NOT adjust the tractor for a faster overall speed forward or reverse than it was designed for.

Neutral Adjustment

If the tractor "creeps" while the ground speed control levers are locked in their NEUTRAL positions, see your dealer.

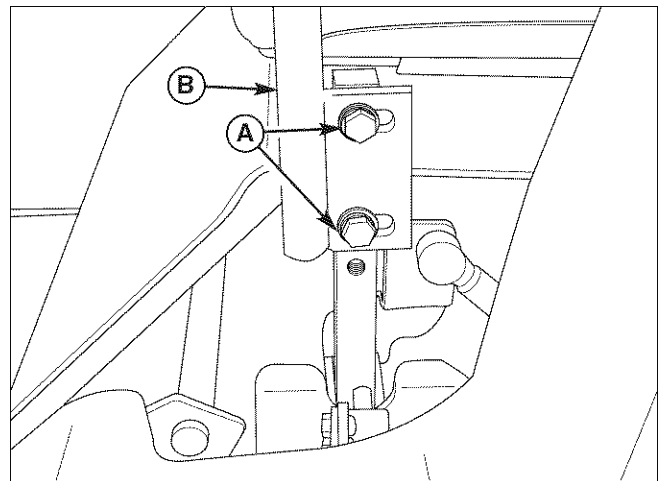

Figure 32. Control Lever Adjustment

A. Placement Hardware

B. Ground Speed Control Lever

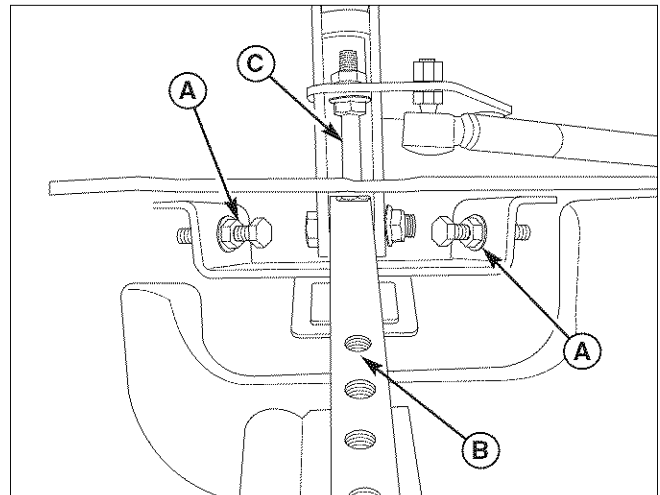

Figure 33. Top Speed Adjustment

A. Top Speed Adjustment Bolt

B. Control Lever Base

C. Alignment Hardware

Parking Brake Adjustment

1. Disengage the PTO, stop the engine, engage the parking brake, and remove the key from the ignition.
2. Raise the seat plate to gain access to the parking brake components.
3. Measure the distance from the top of the brake spring rod (C, Figure 34) to the top of the lock nut (D) on both sides of the unit. The measurement should be .50" (1,27 cm). If not, adjust the locknut to achieve the measurement of .50" (1,27 cm)
4. Measure the distance between the bottom of the brake shaft weldment (G) and the top of the set collar (F). The measurement should be .375" (0,95 cm). If not, position the set collar until the measurement equals .375" (0,95 cm).

If this does not correct the braking problem, see your Snapper Pro dealer.

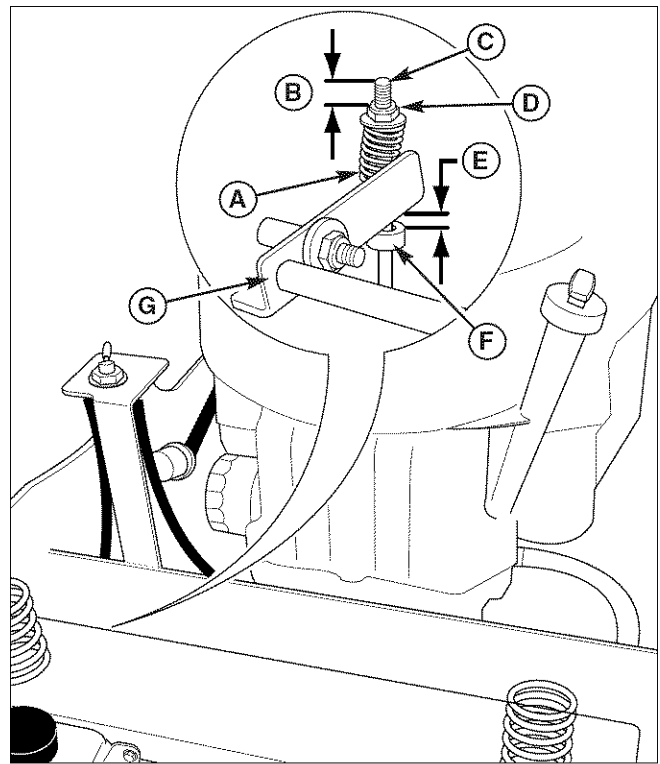

Figure 34. Parking Brake Adjustment

- A. Brake Spring
- B. First Measurement - .50" (1,27 cm)
- C. Brake Spring Rod
- D. Lock Nut
- E. Second Measurement - .375" (0,95 cm)
- F. Set Collar
- G. Brake Shaft Weldment

Return-to-Neutral Adjustment

To determine if it is necessary to adjust the neutral return, perform the following steps.

1. Disengage the PTO, engage the parking brake and turn off the engine.
2. Move the ground speed control levers into the operating position, pull the levers rearward and release.
3. Move the ground speed control levers out towards the neutral position. If the levers do not align with the notches in the neutral lock plate, it is necessary to adjust the neutral return rod (B, Figure 35).

Adjustment

WARNING

To avoid serious injury, perform adjustments only with the engine stopped, the key removed and the tractor on level ground.

1. Disengage the PTO, engage the parking brake and turn off the engine.
2. There are three jam nuts (A, Figure 35) on the linkage rod (B). The first two are used together to turn the rod and the third (towards the front of the machine) is used to lock the rod in place. Loosen the jam nut that locks against the ball joint and turn the linkage rod to adjust. If the machine creeps forward, turn the linkage rod **CLOCKWISE** (while standing at the rear of the machine, facing forward). If the machine creeps backward, turn the rod **COUNTER-CLOCKWISE**.
3. Lock the jam nut (A) against the ball joint when neutral is achieved.
4. Pull the ground speed control lever rearward and release to check position again. Adjust as necessary to align the ground speed control levers with the notches in the neutral lock plate.

NOTE: This adjustment should not be performed while the machine is running.

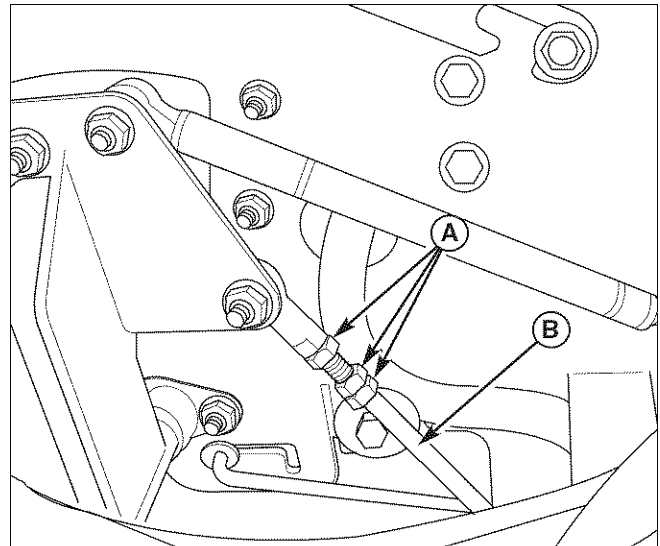

Figure 35. Return-to-Neutral Adjustment
A. Jam Nuts
B. Neutral Return Rod

Deck Rod Timing Adjustment

1. Park the machine on a flat, level surface. Disengage the PTO, engage the parking brake, turn off the engine, and remove the ignition key. Rear tires must be inflated to 15 psi (1,03 bar); front tires to 40 psi (2,76 bar).
2. To check the lift rod timing, measure and record the distance between the lift pivots and the rod pivots. Repeat for other side of unit. See Figure 36.
3. If the measurements for the rods are equal, no further adjustment is required. If the measurements are NOT equal (greater than 1/8" (3,17 mm) difference), adjustment is required continue with Step 4.
4. Lock the deck lift pedal in the 4-1/2" (11,47 cm) position. Remove the cutting height adjustment pin and lower the mower deck.
5. To ensure that the deck is in the lowest position, push the pedal by hand towards the rear of the unit and install the height adjustment pin in the 3" (7,6 cm) position to hold in place.
6. Block up the mower deck until all hanger chains are slack. Refer to Figure 38.
7. See Figure 37. To adjust the lift rod, loosen the jam nut on the front clevis then remove the 1/2" clevis pin fastening the clevis to the lift pivot arm. Turn the clevis clockwise to shorten the distance between the rod pivots or counterclockwise to lengthen the distance between the rod pivots. Reinstall the clevis on the lift pivot arm and secure with the 1/2" clevis pin previously removed. Tighten the jam nut against the clevis.
8. Remove the blocks from the under the mower deck.
9. Remove the cutting height adjustment pin from in front of the deck lift pedal arm. Lift mower deck and reinstall adjustment pin in desired mowing height.

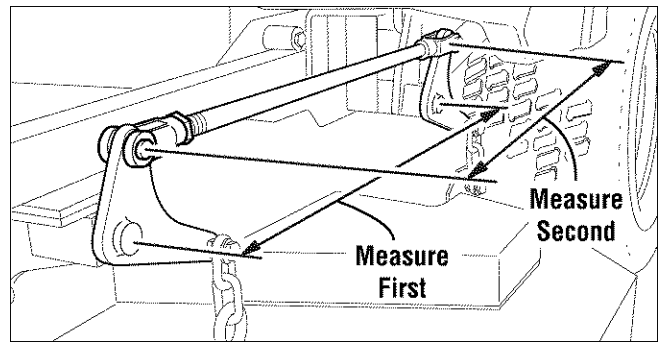

Figure 36. Check Lift Rod Timing

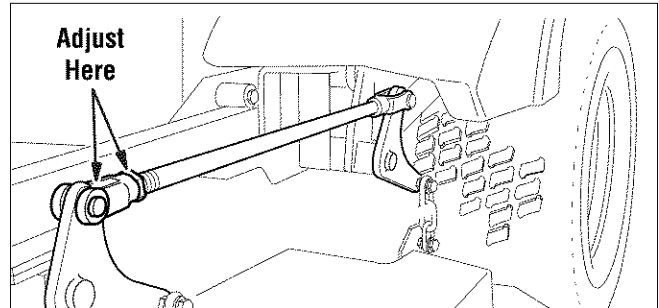

Figure 37. Adjust Lift Rod Timing

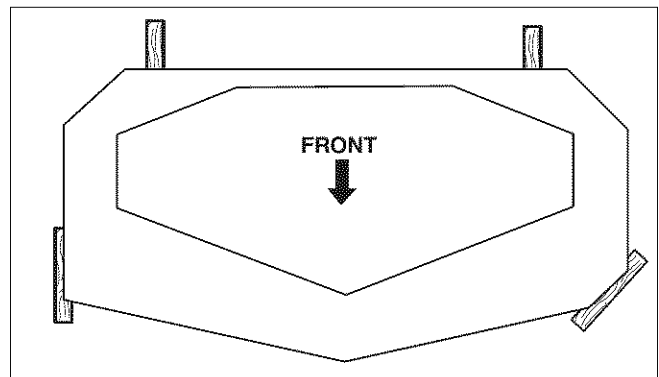

Figure 38. 2 x 4 Locations

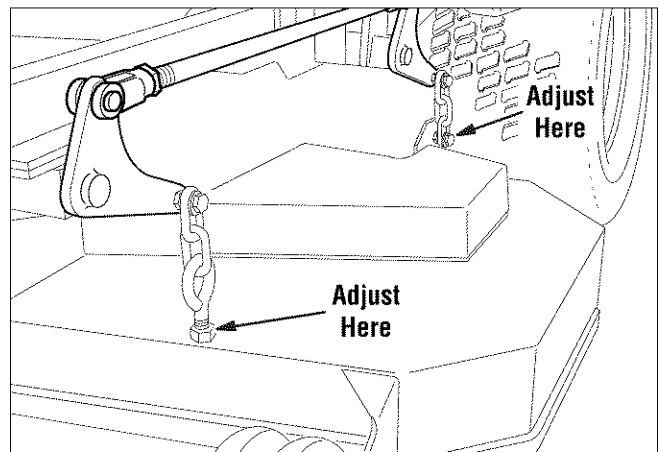

Figure 39. Hanger Chain Adjustment

Deck Leveling Adjustment

NOTE: Before adjusting the deck level, the deck lift rod timing must be checked and/or adjusted.

1. Park the machine on a flat, level surface. Disengage the PTO, stop the engine and engage the parking brake. Rear tires must be inflated to 15 psi (1,03 bar); front tires to 40 psi (2,76 bar).
2. Lock the deck lift pedal in the 4-1/2" (11,47 cm) position. Place the deck height adjustment pin in the 4" position and lower the deck lift pedal until the arm contacts the pin.
3. Place 2 x 4 blocks under each corner of the mower deck with the 3-1/2" sides being vertical. Place a 1/4" (0,64 cm) thick spacer on top of the rear 2 x 4 blocks. See Figure 38.
4. Adjust the front eyebolts until the chains are tight and the deck is still resting on the 2 x 4's. Tighten the jam nuts. See Figure 39.
5. Loosen the nuts and allow the rear of the deck to rest on the 2 x 4's and 1/4" spacers. Slide the chains down in the slots until the chains are tight and tighten the nuts. See Figure 39.
6. Remove all 2 x 4 blocks and spacers from under the mower deck.

Mower Belt Replacement - 48" Deck Models

NOTICE

To avoid damaging belts, **DO NOT PRY BELTS OVER PULLEYS.**

1. Park the tractor on a smooth, level surface such as a concrete floor. Disengage the PTO, engage the parking brake, turn off the engine, and remove the ignition key.
2. Lower the mower deck to its lowest cutting position and remove the mower deck guards.
3. Using a 1/2" breaker bar, place the square end in the square hole located in the end of the idler arm (A, Figures 40). Carefully rotate the breaker bar **CLOCKWISE**, which will relieve the tension on the belt exerted from the idler arm.

⚠ WARNING

Use extreme caution when rotating the idler arm with the breaker bar, due to the increased tension in the spring as the idler arm is being rotated. Injury may result if the breaker bar is prematurely released while the spring is under tension.

4. Slide the drive belt over the edge of the stationary idler pulley (B). Carefully release the tension on the breaker bar.
5. Remove the old belt and replace with a new one. Make sure the V-side of the belt runs in the pulley grooves (Figure 41).
6. Install the drive belt on the PTO pulley, the spindle pulleys and all idler pulleys except the stationary pulley (B, Figure 40). Carefully rotate the breaker bar **CLOCKWISE** and install the belt on the stationary idler pulley (B). Carefully release the tension on the breaker bar.
7. Reinstall the mower deck guards.
8. Run the mower under no-load condition for about 5 minutes to break-in the new belt.

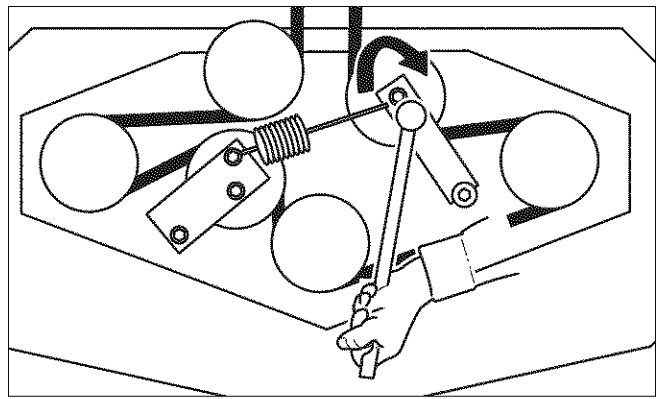

Figure 40. Mower PTO Belt

- A. Idler Arm
- B. Stationary Idler Pulley

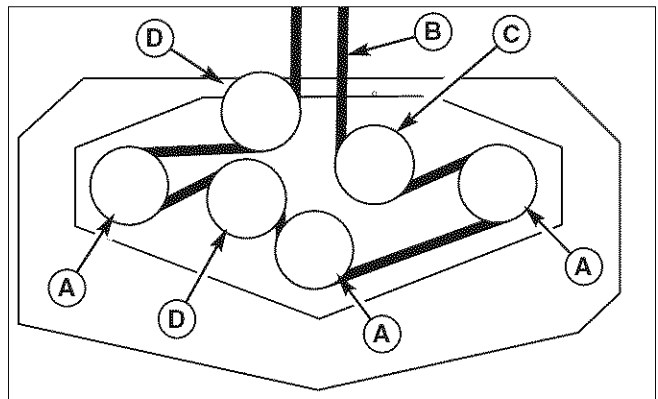

Figure 41. Mower PTO Belt Routing

- A. Spindle Pulley
- B. PTO Drive Belt
- C. Spring-loaded Idler Pulley
- D. Stationary Idler Pulley

Hydraulic Pump Drive Belt Replacement

1. Park the tractor on a smooth, level surface such as a concrete floor. Disengage the PTO, engage the parking brake, turn off the engine, and remove the ignition key.
2. Remove the PTO drive belt (see MOWER BELT REPLACEMENT for removal instructions).
3. Loosen and remove the crankshaft bolt (C, Figure 42) and the PTO clutch (B) from the engine crankshaft.

⚠ WARNING

STORED ENERGY DEVICE: Improper release of the belt tension spring can result in personal injury. Use extreme caution when removing this spring.

4. Loosen the nut on the spring anchor eyebolt (G, Figure 43) to release the majority of the belt tension. Use caution and remove the nut to completely release the tension.

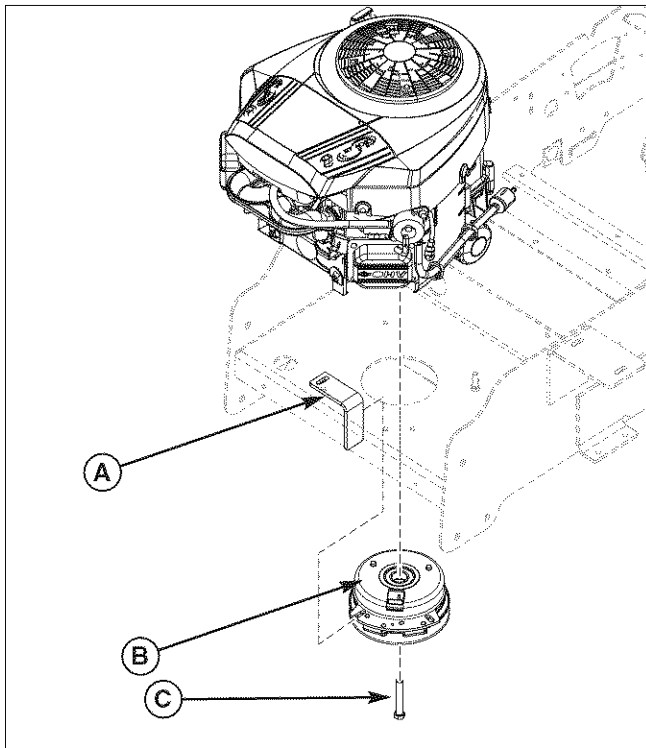

Figure 42. Removing the PTO Clutch
 A. PTO Clutch Mounting Tab
 B. PTO Clutch
 C. Crankshaft Bolt

5. Remove the old belt and replace it with the new one. Make sure the V-side of the belt runs in the grooves of the crankshaft pulley and the transmission pulleys (B & C).
6. Reinstall the spring anchor eyebolt (G) into the anchor tab and loosely fasten the nut. Adjust the anchor eyebolt until a measurement of 5-7/8" (14.92 cm) is achieved from the outside of the spring hooks. Tighten nut.
7. Reinstall the PTO clutch to the engine crankshaft and secure with the crankshaft bolt. Tighten the crankshaft bolt to 65 ft. lbs (88 Nm).

NOTE: Make sure that the slot in the PTO clutch lines up with the PTO clutch mounting tab (A, Figure 42) underneath the engine deck.

8. Reinstall the PTO drive belt.

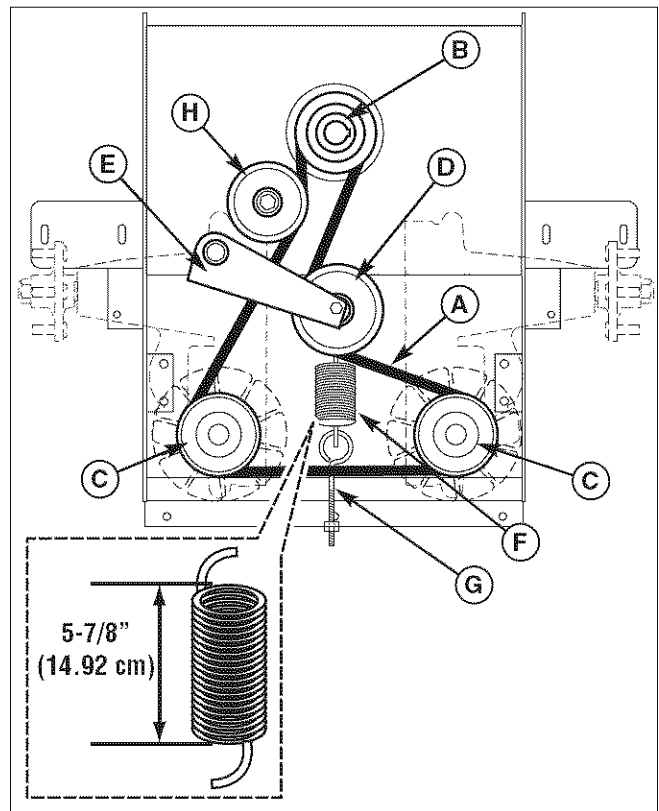

Figure 43. Hydraulic Pump Drive Belt Replacement
 A. Pump Drive Belt
 B. Crankshaft Pulley
 C. Pump Pulley
 D. Idler Pulley
 E. Idler Arm
 F. Spring
 G. Spring Anchor Eyebolt
 H. Stationary Idler Pulley

Battery Maintenance

NOTE: This unit is equipped with a maintenance-free BCIU1 battery.

Cleaning the Battery and Cables

⚠ WARNING

Be careful when handling the battery. Avoid spilling electrolyte. Keep flames and sparks away from the battery.

When removing or installing battery cables, disconnect the negative cable **FIRST** and reconnect it **LAST**. If not done in this order, the positive terminal can be shorted to the frame by a tool.

1. Disconnect the cables from the battery, negative (black) cable first (B, Figure 44).
2. Clean the battery terminals and cable ends with a wire brush until shiny.
3. Reinstall the battery and reattach the battery cables, positive (red) cable first (A).
4. Coat the cable ends and battery terminals with petroleum jelly or non-conducting grease.

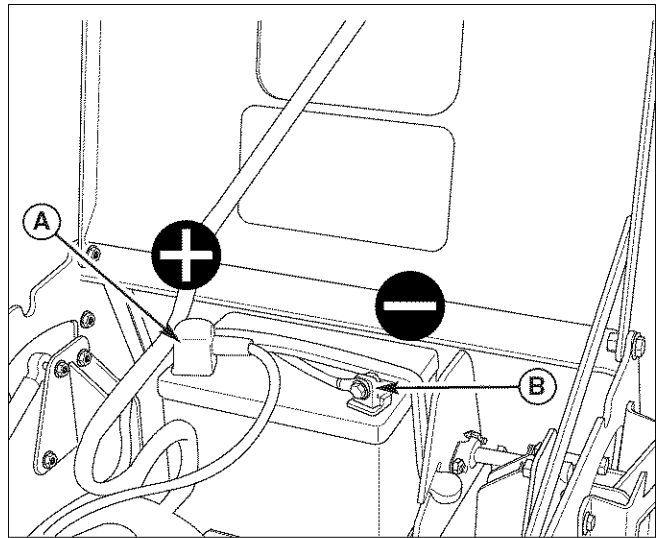

Figure 44. Battery Compartment
A. Positive (+) Cable & Terminal
B. Negative (-) Cable & Terminal

Battery Service

Checking Battery Voltage



WARNING

Keep open flames and sparks away from the battery; the gasses coming from it are highly explosive. Ventilate the battery well during charging.

A voltmeter can be used to determine condition of battery. When engine is off, the voltmeter shows battery voltage, which should be 12 volts. When engine is running, the voltmeter shows voltage of charging circuit which normally is 13 to 14 volts.

A dead battery or one too weak to start the engine may not mean the battery needs to be replaced. For example, it may mean that the alternator is not charging the battery properly. If there is any doubt about the cause of the problem, see your dealer. If you need to replace the battery, follow the steps under Cleaning the Battery & Cables in the Regular Maintenance Section.

Charging a Completely Discharged Battery

1. Be aware of all the safety precautions you should observe during the charging operation. If you are unfamiliar with the use of a battery charger and hydrometer, have the battery serviced by your dealer.
2. Add distilled water sufficient to cover the plate (fill to the proper level near the end of the charge). If the battery is extremely cold, allow it to warm before adding water because the water level will rise as it warms. Also, an extremely cold battery will not accept a normal charge until it becomes warm.
3. Always unplug or turn the charger off before attaching or removing the clamp connections.
4. Carefully attach the clamps to the battery in proper polarity (usually red to [+] positive and black to [-] negative).
5. While charging, periodically measure the temperature of the electrolyte. If the temperature exceeds 125° F (51.6° C), or if violent gassing or spewing of electrolyte occurs, the charging rate must be reduced or temporarily halted to prevent battery damage.
6. Charge the battery until fully charged (until the specific gravity of the electrolyte is 1.250 or higher and the electrolyte temperature is at least 60° F). The best method of making certain a battery is fully charged, but not over charged, is to measure the specific gravity of a cell once per hour. The battery is fully charged when the cells are gassing freely at low charging rate and less than 0.003 change in specific gravity occurs over a three hour period.

Jump Starting With Auxiliary (Booster) Battery

Jump starting is not recommended. However, if it must be done, follow these directions. Both booster and dis-charged batteries should be treated carefully when using jumper cables. Follow the steps below EXACTLY, being careful not to cause sparks. Refer to Figure 45.

1. Both batteries must be of the same voltage.
2. Position the vehicle with the booster battery adjacent to the vehicle with the discharged battery so that booster cables can be connected easily to the batteries in both vehicles. Make certain vehicles do not touch each other.
3. Wear safety glasses and shield eyes and face from batteries at all times. Be sure vent caps are tight. Place damp cloth over vent caps on both batteries.
4. Connect positive (+) cable to positive post of discharged battery (wired to starter or solenoid).
5. Connect the other end of same cable to same post marked positive (+) on booster battery.
6. Connect the second cable negative (-) to other post of booster battery.
7. Make final connection on engine block of stalled vehicle away from battery. Do not lean over batteries.
8. Start the engine of the vehicle with the booster battery. Wait a few minutes, then attempt to start the engine of the vehicle with the discharged battery.
9. If the vehicle does not start after cranking for thirty seconds, STOP PROCEDURE. More than thirty seconds seldom starts the engine unless some mechanical adjustment is made.
10. After starting, allow the engine to return to idle speed. Remove the cable connection at the engine or frame. Then remove the other end of the same cable from the booster battery.
11. Remove the other cable by disconnecting at the discharged battery first and then disconnect the opposite end from the booster battery.
12. Discard the damp cloths that were placed over the battery vent caps.

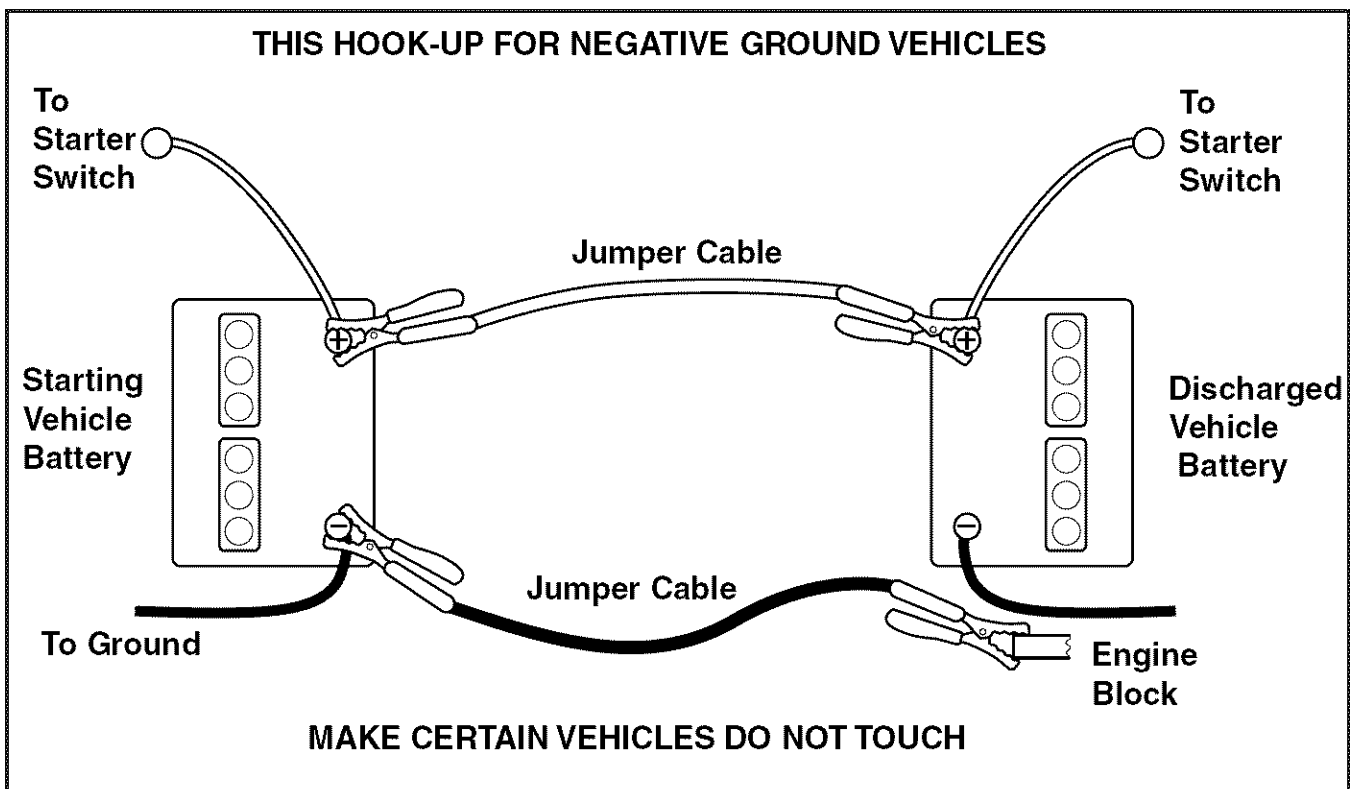

Figure 45. Jump Starting

⚠ WARNING

Any procedure other than the preceding could result in:

- (1) personal injury caused by electrolyte squirting out the battery vents,
- (2) personal injury or property damage due to battery explosion,
- (3) damage to the charging system of the booster vehicle or of the immobilized vehicle.

Do not attempt to jump start a vehicle having a frozen battery because the battery may rupture or explode. If a frozen battery is suspected, examine all fill vents on the battery. If ice can be seen or if the electrolyte fluid cannot be seen, do not attempt to start with jumper cables as long as the battery remains frozen.

⚠ WARNING

For your personal safety, use extreme care when jump starting. Never expose battery to open flame or electric spark – battery action generates hydrogen gas which is flammable and explosive. Do not allow battery acid to contact skin, eyes, fabrics, or painted surfaces. Batteries contain a sulfuric acid solution which can cause serious personal injury or property damage.

When removing or installing battery cables, disconnect the negative cable **FIRST** and reconnect it **LAST**. If not done in this order, the positive terminal can be shorted to the frame by a tool.

To avoid engine damage, do not disconnect battery while engine is running. Be sure terminal connections are tight before starting.

Storage

Temporary Storage (30 Days Or Less)

Remember, the fuel tank will still contain some gasoline, so never store the unit indoors or in any other area where fuel vapor could travel to any ignition source. Fuel vapor is also toxic if inhaled, so never store the unit in any structure used for human or animal habitation.

Here is a checklist of things to do when storing your unit temporarily or in between uses:

- Keep the unit in an area away from where children may come into contact with it. If there's any chance of unauthorized use, remove the spark plug (s) and put in a safe place. Be sure the spark plug opening is protected from foreign objects with a suitable cover.
- If the unit can't be stored on a reasonable level surface, chock the wheels.
- Clean all grass and dirt from the mower.

Long Term Storage (Longer Than 30 Days)

Before you store your unit for the off-season, read the Maintenance and Storage instructions in the Safety Rules section, then perform the following steps:

1. Drain crankcase oil while engine is hot and refill with a grade of oil that will be required when unit is used again.
2. Prepare the mower deck for storage as follows:
 - a. Remove mower deck from the unit.
 - b. Clean underside of mower deck.
 - c. Coat all bare metal surfaces with paint or light coat of oil to prevent rusting.
3. Clean external surfaces and engine.
4. Prepare engine for storage. See engine owner's manual.
5. Clean any dirt or grass from cylinder head cooling fins, engine housing and air cleaner element.
6. Cover air cleaner and exhaust outlet tightly with plastic or other waterproof material to keep out moisture, dirt and insects.
7. Completely grease and oil unit as outlined in the Normal Care section.
8. Clean up unit and apply paint or rust preventative to any areas where paint is chipped or damaged.
9. Be sure the battery is filled to the proper level with water and is fully charged. Battery life will be increased if it is removed, put in a cool, dry place and fully charged about once a month. If battery is left in unit, disconnect the negative cable.

WARNING

Never store the unit, with gasoline in engine or fuel tank, in a heated shelter or in enclosed, poorly ventilated enclosures. Gasoline fumes may reach an open flame, spark or pilot light (such as a furnace, water heater, clothes dryer, etc.) and cause an explosion.

Handle gasoline carefully. It is highly flammable and careless use could result in serious fire damage to your person or property.

Drain fuel into an approved container outdoors away from open flame or sparks.

10. Drain fuel system completely or add a gasoline stabilizer to the fuel system. If you have chosen to use a fuel stabilizer and have not drained the fuel system, follow all safety instructions and storage precautions in this manual to prevent the possibility of fire from the ignition of gasoline fumes. Remember, gasoline fumes can travel to distant sources of ignition and ignite, causing risk of explosion and fire.

NOTE: Gasoline, if permitted to stand unused for extended periods (30 days or more), may develop gummy deposits which can adversely affect the engine carburetor and cause engine malfunction. To avoid this condition, add a gasoline stabilizer to the fuel tank and run the engine a few minutes, or drain all fuel from the unit before placing it in storage.

Starting After Long Term Storage

Before starting the unit after it has been stored for a long period of time, perform the following steps.

1. Remove any blocks from under the unit.
2. Install the battery if it was removed.
3. Unplug the exhaust outlet and air cleaner.
4. Fill the fuel tank with fresh gasoline. See engine manual for recommendations.
5. See engine owner's manual and follow all instructions for preparing engine after storage.
6. Check crankcase oil level and add proper oil if necessary. If any condensation has developed during storage, drain crankcase oil and refill.
7. Inflate tires to proper pressure. Check fluid levels.
8. Start the engine and let it run slowly. DO NOT run at high speed immediately after starting. Be sure to run engine only outdoors or in well ventilated area.

Troubleshooting

Troubleshooting Chart

While normal care and regular maintenance will extend the life of your equipment, prolonged or constant use may eventually require that service be performed to allow it to continue operating properly.

The troubleshooting guide below lists the most common problems, their causes and remedies.

See the information on the following pages for instructions on how to perform most of these minor adjustments and service repairs yourself. If you prefer, all of these procedures can be performed for you by your local authorized dealer.

WARNING

To avoid serious injury, perform maintenance on the tractor or mower only when the engine is stopped and the parking brake engaged.

Always remove the ignition key, disconnect the spark plug wire and fasten it away from the plug before beginning the maintenance, to prevent accidental starting of the engine.

Troubleshooting the Rider

Problem	Cause	Remedy
Engine will not turnover or start.	<ol style="list-style-type: none"> 1. Parking brake not engaged. 2. PTO (electric clutch) switch in ON position. 3. Ground speed control levers not in "NEUTRAL" position. 4. Out of fuel. 5. Engine flooded. 6. Fuse blown. 7. Battery terminals require cleaning. 8. Battery discharged or dead. 9. Wiring loose or broken. 10. Solenoid or starter motor faulty. 11. Safety interlock switch faulty. 12. Spark plug(s) faulty, fouled or incorrectly gapped. 13. Water in fuel. 14. Gas is old or stale. 	<ol style="list-style-type: none"> 1. Engage parking brake. 2. Place in OFF position. 3. Move ground speed control levers to "NEUTRAL" position. 4. If engine is hot, allow it to cool, then refill the fuel tank. 5. Move choke control to closed position. 6. Replace fuse. 7. Clean the battery terminals 8. Recharge or replace. 9. Visually check wiring & replace broken or frayed wires. Tighten loose connections. 10. Repair or replace. See authorized dealer 11. Replace as needed. See authorized service dealer. 12. Clean and gap or replace. See engine manual. 13. Drain fuel & replace with fresh fuel. 14. Drain fuel & replace with fresh fuel.
Engine starts hard or runs poorly.	<ol style="list-style-type: none"> 1. Fuel mixture too rich. 2. Spark plug faulty, fouled, or incorrectly gapped. 	<ol style="list-style-type: none"> 1. Clean air filter. Check choke adjustment. 2. Clean and gap or replace. (See engine manual.)
Engine knocks.	<ol style="list-style-type: none"> 1. Low oil level. 2. Using wrong grade oil. 	<ol style="list-style-type: none"> 1. Check/add oil as required. 2. See engine manual.
Excessive oil consumption.	<ol style="list-style-type: none"> 1. Engine running too hot. 2. Using wrong weight oil. 3. Too much oil in crankcase. 	<ol style="list-style-type: none"> 1. Clean engine fins, blower screen and air cleaner. 2. See engine manual. 3. Drain excess oil.
Engine exhaust is black.	<ol style="list-style-type: none"> 1. Dirty air filter. 2. Engine choke control is in closed position. 	<ol style="list-style-type: none"> 1. Replace air filter. See engine manual. 2. Open choke control.

Rider Troubleshooting Continued.

Problem	Cause	Remedy
Engine runs, but rider will not drive.	<ol style="list-style-type: none"> 1. Transmission release lever(s) in "open" position. 2. Belt is broken. 3. Drive belt slips. 4. Brake is not fully released. 	<ol style="list-style-type: none"> 1. Move the transmission release lever(s) to the "closed" position. 2. See Drive Belt Replacement. 3. See problem and cause below. 4. See authorized service dealer
Rider drive belt slips.	<ol style="list-style-type: none"> 1. Pulleys or belt greasy or oily. 2. Tension too loose. 3. Belt stretched or worn. 	<ol style="list-style-type: none"> 1. Clean as required. 2. Adjust spring tension. See Drive Belt Replacement 3. Replace belt.
Brake will not hold.	<ol style="list-style-type: none"> 1. Brake is incorrectly adjusted. 2. Brake pads worn. 	<ol style="list-style-type: none"> 1. See Brake Adjustment. 2. Replace with new brake pads.
Rider steers or handles poorly.	<ol style="list-style-type: none"> 1. Steering linkage is loose. 2. Improper tire inflation. 	<ol style="list-style-type: none"> 1. Check and tighten any loose connections. 2. See Regular Maintenance Section.

Troubleshooting the Mower

Problem	Cause	Remedy
Mower will not raise.	<ol style="list-style-type: none"> 1. Lift linkage not properly attached or damaged. 	<ol style="list-style-type: none"> 1. See authorized service dealer for repair.
Engine stalls easily with mower engaged.	<ol style="list-style-type: none"> 1. Engine speed too slow. 2. Ground speed too fast. 3. Cutting height set too low. 4. Discharge chute jamming with cut grass. 	<ol style="list-style-type: none"> 1. Set to full throttle. 2. Decrease Ground Speed. 3. Cut tall grass at maximum cutting height during first pass. 4. Cut grass with discharge pointing toward previously cut area.
Excessive mower vibration.	<ol style="list-style-type: none"> 1. Blade mounting bolts are loose. 2. Mower blades, arbors, or pulleys are bent. 3. Mower blades are out of balance. 4. Belt installed incorrectly. 	<ol style="list-style-type: none"> 1. Tighten to 70 ft.lbs. (94 N.m.). 2. Check and replace as necessary. 3. Remove, sharpen, and balance blades. See Maintenance Section. 4. Reinstall Correctly.
Excessive belt wear or breakage.	<ol style="list-style-type: none"> 1. Bent or rough pulleys. 2. Using incorrect belt. 	<ol style="list-style-type: none"> 1. Repair or replace. 2. Replace with correct belt.
Mower drive belt slips or fails to drive.	<ol style="list-style-type: none"> 1. Idler pulley spring broken or not properly attached. 2. Mower drive belt broken. 	<ol style="list-style-type: none"> 1. Repair or replace as needed. 2. Replace drive belt.
Mower does not engage.	<ol style="list-style-type: none"> 1. Electrical wiring damage. 2. PTO clutch not adjusted 3. Battery voltage too low. 	<ol style="list-style-type: none"> 1. Locate & repair damaged wire. 2. See PTO Clutch Adjustment section 3. Recharge battery and check alternator. See Battery Maintenance section.

Troubleshooting Common Cutting Problems

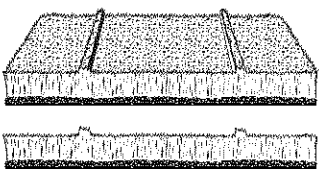
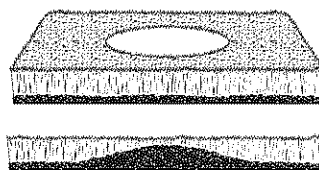
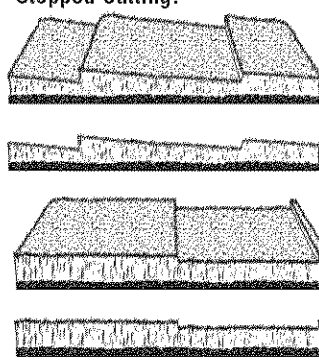
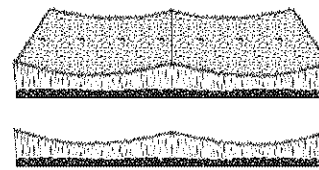
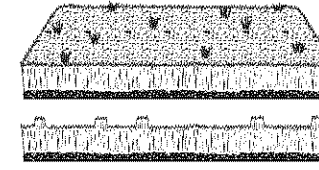
Problem	Cause	Remedy
Streaking. 	<ol style="list-style-type: none"> 1. Blades are not sharp. 2. Blades are worn down too far. 3. Engine speed is too slow. 4. Ground speed is too fast. 5. Deck is plugged with grass 6. Not overlapping cutting rows enough. 7. Not overlapping enough when turning. 	<ol style="list-style-type: none"> 1. Sharpen your blades. 2. Replace your blades. 3. Always mow at full throttle. 4. Slow down. 5. Clean out the mower. 6. Overlap your cutting rows. 7. When turning your effective cutting width decreases—overlap more when turning.
Scalping. 	<ol style="list-style-type: none"> 1. Lawn is uneven or bumpy. 2. Mower deck cutting height is set too low. 3. Ground speed is too fast. 4. Deck is not leveled correctly. 5. Tire pressure is low or uneven 	<ol style="list-style-type: none"> 1. Roll or level the lawn. 2. Raise the cutting height. 3. Slow down. 4. Correctly level the deck. 5. Check and inflate the tires.
Stepped Cutting. 	<ol style="list-style-type: none"> 1. Deck is not leveled correctly. 2. Tires are not properly inflated. 3. Blades are damaged. 4. Deck shell is damaged. 5. Mower spindle is bent or loose. 6. Blades are installed incorrectly. 	<ol style="list-style-type: none"> 1. Level the deck correctly. 2. Check and inflate the tires. 3. Replace the blades. 4. Repair or replace the deck. 5. Repair or replace the spindle. 6. Reinstall the blades correctly.
Uneven Cutting. 	<ol style="list-style-type: none"> 1. Deck is not leveled correctly. 2. Blades are dull or worn. 3. Blades are damaged. 4. Deck is clogged with grass clippings. 5. Deck shell is damaged. 6. Mower spindle is bent or loose. 7. Blades are installed incorrectly. 8. Tires are not properly inflated. 	<ol style="list-style-type: none"> 1. Level the deck correctly. 2. Sharpen or replace the blades. 3. Replace the blades. 4. Clean out the deck. 5. Repair or replace the deck. 6. Repair or replace the spindle. 7. Reinstall the blades correctly. 8. Check and inflate the tires.
Stingers. 	<ol style="list-style-type: none"> 1. Blades are not sharp or nicked. 2. Blades are worn down too far. 3. Engine speed is too slow. 4. Ground speed is too fast. 5. Deck is plugged with grass. 	<ol style="list-style-type: none"> 1. Sharpen your blades. 2. Replace your blades. 3. Always mow at full throttle. 4. Slow down. 5. Clean out the mower.

Specifications

NOTE: Specifications are correct at time of printing and are subject to change without notice.

ENGINE:

26 HP Briggs & Stratton

Make	Briggs & Stratton
Model	44P777-0124-G1
Horsepower	26 @ 3600 rpm
Displacement	44.2 Cu. in (724 cc)
Electrical System	12 Volt Starter, 16 amp. Alternator, Battery: 340 CCA
Oil Capacity	2.0 US qt.. (1.9 L) w/ Filter

CHASSIS:

Fuel Tank	Capacity: 8 Gallons (30,3 L)
Rear Wheels	Tire Size: 20 x 8.00 -10 (48" Model) Inflation Pressure: 15 psi (1,03 bar)
Front Wheels	Tire Size: 11 x 4.00 - 5 Inflation Pressure: 40 psi (2,76 bar)

TRANSMISSIONS:

HydroGear ZL-KMEF-3L7C-1LLX (LH)

HydroGear ZL-GMEF-3L7B-1LLX (RH)

Type	ZT2800
Hydraulic Fluid	SAE 20W-50 motor oil
Speeds	Forward: 0-7 MPH (0-11,27 km/h)
@ 3400 rpm	Reverse: 0-5 MPH (0-8.05 km/h)
Continuous Torque	180 ft. lbs. (244 N.m.)
Output	
Maximum Weight on Axle	440 lbs. (200 Kg) per axle

DIMENSIONS:

Overall Length:	68" (173 cm)
Overall Width	
48" Model:	49" (125 cm)
Height:	43" (109 cm)
Weight (apx.):	750 lbs. (340 kg)

Engine Power Rating Information

The gross power rating for individual gas engine models is labeled in accordance with SAE (Society of Automotive Engineers) code J1940 (Small Engine Power & Torque Rating Procedure), and rating performance has been obtained and corrected in accordance with SAE J1995 (Revision 2002-05). Torque values are derived at 3060 RPM; horsepower values are derived at 3600 RPM. Actual gross engine power will be lower and is affected by, among other things, ambient operating conditions and engine-to-engine variability. Given both the wide array of products on which engines are placed and the variety of environmental issues applicable to operating the equipment, the gas engine will not develop the rated gross power when used in a given piece of power equipment (actual "on-site" or net horsepower). This difference is due to a variety of factors including, but not limited to, accessories (air cleaner, exhaust, charging, cooling, carburetor, fuel pump, etc.), application limitations, ambient operating conditions (temperature, humidity, altitude), and engine-to-engine variability. Due to manufacturing and capacity limitations, Briggs & Stratton may substitute an engine of higher rated power for this Series engine.

SLOPE IDENTIFICATION GUIDE

1 FOLD ALONG APPROPRIATE DOTTED LINE

THIS IS A 15 DEGREE SLOPE

THIS IS A 10 DEGREE SLOPE

**2 ALIGN THIS EDGE WITH A VERTICAL SURFACE
(TREE, POLE, FENCE POST, BUILDING, ETC)**

**3 COMPARE THE ANGLE
OF THE FOLD TO THE
ANGLE OF THE SLOPE**

INSTRUCTIONS

1. Fold this page along the dotted line indicated above.
2. Align the left edge of this guide with a vertical tree, a power line pole, a fence post, or any vertical structure.
3. Compare the angle of the fold with the angle of the hill.

SNAPPER®

ZERO-TURN RIDING MOWER

Product Specifications:

ENGINE:

26 HP Briggs & Stratton

Make	Briggs & Stratton
Model	44P777-0124-G1
Oil Capacity	2.0 US qt. (1,9 L) w/ Filter

CHASSIS:

Fuel Tank	Capacity: 8 Gallons (30,3 L)
Rear Wheels	Tire Size: 20 x 8.00 -10 (48" Model) Inflation Pressure: 15 psi (1,03 bar)
Front Wheels	Tire Size: 11 x 4.00 - 5 Inflation Pressure: 40 psi (2,76 bar)

Common Service Parts:

BELTS AND BLADES:

TRACTOR

Pump Drive Belt	5022173
------------------------	---------

48" MOWER DECK

Deck Drive Belt	5101301
Mower Blade	5020843

SNAPPER®

535 Macon St.
McDonough, GA 30253

www.snapper.com