

Safety Instructions & Operator's Manual for **SNAPPER**[®]

REAR ENGINE RIDING MOWER SERIES 23



MODELS	
281123BV	301223BVE
2811523BV	3012523BVE
281223BVE	3013523BVE
2812523BVE	331323HVE
2813523BVE	331523KVE
301123BV	331623BVE
3011523BV	331723BVE

MODEL NUMBER EXPLANATION					
33	15	23	K	V	E
CUTTING WIDTH _____	ENGINE HP * _____	SERIES DESIGNATION _____	ENGINE OPTIONS _____	ENGINE TYPE _____	ENGINE MODEL _____
28 - 28" Cutting Deck	11 - 11.0 HP Engine	135 - 13.5 HP Engine	23 - Series Designation	B - Briggs Engine	V - Over Head Valve
30 - 30" Cutting Deck	115 - 11.5 HP Engine	15 - 15.0 HP Engine		K - Kohler Engine	E - Electric Start
33 - 33" Cutting Deck	12 - 12.0 HP Engine	16 - 16.0 HP Engine		H - Honda Engine	
	125 - 12.5 HP Engine	17 - 17.0 HP Engine			
	13 - 13.0 HP Engine				

Thank you for buying a SNAPPER Product! Before operating your machine, read this manual carefully and pay particular attention to the "IMPORTANT SAFETY INSTRUCTIONS" on Pages 2 thru 4. Remember that all power equipment can be dangerous if used improperly. Also keep in mind that SAFETY requires careful use in accordance with the operating instructions and common sense!

NOTE: Specifications are correct at time of printing and are subject to change without notice.

* Actual sustained equipment horsepower will likely be lower due to operating limitations and environmental factors. Please refer to 'Engine Power Rating Information' on Page 4 for further information.

SNAPPER McDonough, GA., 30253 U.S.A.



IMPORTANT SAFETY INSTRUCTIONS



WARNING: This powerful cutting machine is capable of amputating hands and feet and can throw objects that can cause injury and damage! Failure to comply with the following **SAFETY** instructions could result in serious injury or death to the operator or other persons. The owner of the machine must understand these instructions and must allow only persons who understand these instructions to operate machine. Each person operating the machine must be of sound mind and body and must not be under the influence of any substance, which might impair vision, dexterity or judgment. If you have any questions pertaining to your machine which your dealer cannot answer to your satisfaction, call or write the Customer Service Department at SNAPPER, McDonough, Georgia 30253. Phone: (1-800-935-2967).

PROTECTION FOR CHILDREN

Tragic accidents can occur if the operator is not alert to the presence of children. Children are often attracted to the machine and the mowing activity. Children who have been given rides in the past may suddenly appear in the mowing area for another ride and be run over or backed over by the machine. Never assume that children will remain where you last saw them.

1. **KEEP** children out of the mowing area and under the watchful care of a responsible adult other than the operator.
2. **DO NOT** allow children in yard when machine is operated (even with the blade OFF).
3. **DO NOT** allow children or others to ride on machine, attachments or towed equipment (even with the blades OFF). They may fall and be seriously injured.
4. **DO NOT** allow pre-teenage children to operate machine.
5. **ALLOW** only responsible adults & teenagers with mature judgment under close adult supervision to operate machine.
6. **DO NOT** operate blades in reverse. **STOP BLADES. LOOK and SEE** behind and down for children, pets and hazards before and while backing.
7. **USE EXTRA CARE** when approaching blind corners, shrubs, trees, or other objects that may obscure vision.

PROTECTION AGAINST TIPOVERS

Slopes are a major factor related to loss-of-control and tip-over accidents, which can result in severe injury or death. All slopes require extra **CAUTION**. If you cannot back up the slope or if you feel uneasy on the slope, **DO NOT** mow it. Use extra care with grass catchers or other attachments; these affect the handling and the stability of the machine.

1. **DO NOT** operate machine on slopes exceeding 15 degrees (27% grade).
2. Exercise **EXTREME CAUTION** on slopes above 10 degrees (18% grade). Turn blades OFF when traveling uphill. Use a slow speed and avoid sudden or sharp turns.
3. **DO NOT** operate machine back and forth across face of slopes. Operate up and down. Practice on slopes with blades off.
4. **AVOID** starting, stopping or turning on slopes. If machine stops going uphill or tires lose traction, turn blades OFF and back slowly straight down the slope.

PROTECTION AGAINST TIPOVERS

(Continued From Previous Column)

5. **STAY ALERT** for holes and other hidden hazards. Tall grass can hide obstacles. Keep away from ditches, washouts, culverts, fences and protruding objects.
6. **KEEP A SAFE DISTANCE** (at least 3 feet) away from edge of ditches and other drop offs. The machine could turn over if an edge caves in.
7. Always begin forward motion slowly and with caution.
8. Use weights or a weighted load carrier in accordance with instructions supplied with a grass catcher. **DO NOT** operate machine on slopes exceeding 10 degrees (18% grade) when equipped with grass catcher.
9. **DO NOT** put your foot on the ground to try to stabilize the machine.
10. **DO NOT** operate machine on wet grass. Reduced traction could cause sliding.
11. Choose a low enough speed setting so that you will not have to stop or shift on a slope. Tires may lose traction on slopes even though the brakes are functioning properly.
12. **DO NOT** operate machine under any condition where traction, steering or stability is doubtful.
13. Always keep the machine in gear when going down slopes. **DO NOT** shift to neutral (or actuate hydro roll release) and coast downhill.

PREPARATION

1. Read, understand, and follow instructions and warnings in this manual and on the machine, engine and attachments. Know the controls and the proper use of the machine before starting.
2. Only mature, responsible persons shall operate the machine and only after proper instruction.
3. Data indicates that operators age 60 and above, are involved in a large percentage of mower-related injuries. These operators should evaluate their ability to operate the mower safely enough to protect themselves and others from serious injury.
4. Handle fuel with extra care. Fuels are flammable and vapors are explosive. Use only an approved fuel container. **DO NOT** remove fuel cap or add fuel with engine running. Add fuel outdoors only with engine stopped and cool. Clean spilled fuel from machine. **DO NOT** smoke.
5. Practice operation of machine with **BLADES OFF** to learn controls and develop skills.



IMPORTANT SAFETY INSTRUCTIONS



PREPARATION

(Continued From Previous Page)

6. Check the area to be mowed and remove all objects such as toys, wire, rocks, limbs and other objects that could cause injury if thrown by blade or interfere with mowing.
7. Keep people and pets out of mowing area. Immediately STOP blades, STOP engine, and STOP machine if anyone enters the area.
8. Check shields, deflectors, switches, blade controls and other safety devices frequently for proper operation and location.
9. Make sure all safety decals are clearly legible. Replace if damaged.
10. Protect yourself when mowing and wear safety glasses, long pants and substantial footwear.
11. Know how to STOP blades and engine quickly in preparation for emergencies.
12. Use extra care when loading or unloading the machine into a trailer or truck.
13. Check grass catcher components frequently for signs of wear or deterioration and replace as needed to prevent injury from thrown objects going through weak or worn spots.

SAFE HANDLING OF GASOLINE

To avoid personal injury or property damage, use extreme care in handling gasoline. Gasoline is extremely flammable and the vapors are explosive

1. Extinguish all cigarettes, cigars, pipes and other sources of ignition.
2. Use only an approved fuel container.
3. DO NOT remove fuel cap or add fuel with the engine running. Allow the engine to cool before refueling.
4. DO NOT refuel the machine indoors.
5. DO NOT store the machine or fuel container inside where there is an open flame, spark or pilot light such as on a water heater or other appliances.
6. DO NOT fill fuel containers inside a vehicle or on a truck or trailer bed with a plastic liner. Always place the containers on the ground away from the vehicle before filling.
7. Remove gas-powered equipment from the vehicle or trailer and refuel it on the ground. If this is not possible, then refuel equipment using a portable container, rather than a gasoline dispenser nozzle.
8. DO NOT start gas powered equipment in enclosed vehicles or trailers.
9. Keep the nozzle in contact with the rim of the fuel tank or container opening at all times until fueling is complete. DO NOT use a nozzle lock-open device
10. If fuel is spilled on clothing, change clothing immediately.
11. Never overfill a fuel tank. Replace fuel cap and tighten securely.

OPERATION

1. Mount and dismount machine from left side. Keep clear of discharge opening at all times.
2. Start engine from operator's seat, if possible. Make sure blades are OFF and parking brake is set.
3. DO NOT leave machine with engine running. STOP engine, STOP blades, SET brake, and Remove key before leaving operators position of any reason.
4. DO NOT operate machine unless properly seated with feet on feet rests or pedal(s).
5. STOP BLADES and ENGINE and make sure blades have stopped before removing grass catcher or unclogging mower to prevent loss of fingers or hand.
6. Blades must be OFF except when cutting grass. Set blades in highest position when mowing over rough ground.
7. Keep hands and feet away from rotating blades underneath deck. DO NOT place foot on ground while BLADES are ON or machine is in motion.
8. DO NOT operate machine without entire grass catcher or guards in place and working. DO NOT point discharge at people, passing cars, windows or doors.
9. Slow down before turning.
10. Watch out for traffic when near or crossing roadways.
11. STOP engine immediately after striking an obstruction. Inspect machine and repair damage before resuming operation.
12. Operate machine only in daylight or with good artificial light.
13. Move joystick (if equipped) SLOWLY to maintain control during speed and directional changes.
14. Exercise CAUTION when pulling loads. Limit loads to those you can safely control and attach loads to hitch plate as specified with SNAPPER attachment instructions.
15. On slopes, the weight of the towed equipment may cause loss of traction and loss of control. When towing, travel slowly and allow extra distance to stop.
16. DO NOT operate engine in enclosed areas. Engine exhaust gases contain carbon monoxide, a deadly poison.
17. DO NOT discharge material against a wall or obstruction. Material may ricochet back towards the operator.
18. Only use accessories approved by the manufacturer. See manufacturer's instructions for proper operation and installation of accessories.



IMPORTANT SAFETY INSTRUCTIONS



TOWING

1. Tow only with a machine that has a hitch designed for towing. DO NOT attach towed equipment except at the hitch point.
2. Follow the manufacturer's recommendation for weight limits for towed equipment and towing on slopes.
3. DO NOT allow children or others on towed equipment.
4. On slopes, the weight of the towed equipment may cause loss of traction and loss of control.
5. Travel slowly and allow extra distance to stop.

MAINTENANCE

1. DO NOT store machine or fuel container inside where fumes may reach an open flame, spark or pilot light such as in a water heater, furnace, clothes dryer or other gas appliance. Allow engine to cool before storing machine in an enclosure. Store fuel container out of the reach of children in a well ventilated, unoccupied building.
2. Keep engine free of grass, leaves or excess grease to reduce fire hazard and engine overheating.
3. When draining fuel tank, drain fuel into an approved container outdoors and away from open flame.
4. Check brakes frequently; adjust, repair or replace as needed.
5. Keep all bolts, nuts and screws properly tight. Check that all cotter pins are in proper position.

MAINTENANCE

(Continued From Previous Column)

6. Always provide adequate ventilation when running engine. Exhaust gases contain carbon monoxide, an odorless and deadly poison.
7. Disconnect negative (black) cable from battery before performing maintenance or service. Cranking engine could cause injury.
8. DO NOT work under machine without safety blocks.
9. Service engine and make adjustments only when engine is stopped. Remove spark plug wire(s) from spark plug(s) and secure wire(s) away from spark plug(s).
10. DO NOT change engine governor speed settings or overspeed engine.
11. Lubricate machine at intervals specified in manual to prevent controls from binding.
12. Mower blades are sharp and can cut. Wrap the blades or wear heavy leather gloves and use CAUTION when handling them.
13. DO NOT test for spark by grounding spark plug next to spark plug hole; spark plug could ignite gas exiting engine.
14. Have machine serviced by an authorized SNAPPER dealer at least once a year and have the dealer install any new safety devices.
15. Maintain or replace safety and instruction labels as necessary.
16. Use only genuine SNAPPER replacement parts to assure that original standards are maintained.

Engine Power Rating Information

The gross power rating labels for individual gas engine models meet or exceed SAE (Society of Automotive Engineers) code J1940 (Small Engine Power & Torque Rating Procedure) and rating performance has been obtained and corrected in accordance with SAE J1995 (Revision 2002-05). Actual gross engine power may be lower and is affected by, but not limited to, ambient operating conditions and engine to engine variability. Given both the wide array of products on which engines are placed, and the variety of environmental issues applicable to operating the equipment, the gas engine will not develop the rated gross power when used in a given piece of power equipment (actual "on-site" or net horsepower). This difference is due to a variety of factors including, but not limited to, accessories (air cleaner, exhaust, charging, cooling, carburetor, fuel pump, etc.), application limitations, ambient operating conditions (temperature, humidity, altitude), and engine to engine variability.

Statement of Usage

This manual contains safety information to make you aware of the hazards and risks associated with the machine and how to avoid them. This machine is designed and intended to be used and maintained according to the manual for finish cutting of established lawns and is not intended for any other purpose. It is important that you read and understand these instructions thoroughly before attempting to start or operate this equipment.

TABLE OF CONTENTS

IMPORTANT SAFETY INSTRUCTIONS	2-4
TABLE OF CONTENTS	5
SECTION 1 - FAMILIARIZATION	6
SECTION 2 - OPERATING INSTRUCTIONS	7-13
Pre-start Checklist.....	7
Operator's Seat Adjustment	7
Starting & Stopping Engine, Blade & Wheel Drive.....	8-11
Starting & Stopping Mower Blades.....	10-11
Starting & Stopping Wheel Drive	10-11
Parking Brake.....	12
Cutting Height Adjustment	12
Reverse Lockout Mechanism	13
SECTION 3 - MAINTENANCE INSTRUCTIONS	14-19
Service – After First 5 Hours	14-16
Change Engine Oil.....	14
Service Engine Air Cleaner.....	14
Check Mower Blade	14
Check Blade Drive Belt	15
Blade Brake	15
Service Brake / Park Brake	15
Check Interlock System	16
Reverse Lockout Mechanism	16
Lubrication – Grease Fittings – Overview	16
Service – Every 25 Operating Hours	16-18
Check Engine.....	16
Battery Fluid Level	17
Mower Deck Levelness	17
Clean Mower Deck.....	17
Mower Blade Spindle – Lubrication	17
Mower Deck Linkage – Lubrication	17
Front Wheel Bearing – Lubrication.....	17
Shift Lever – Lubrication	17
Rear Axle Bearing – Lubrication.....	18
Differential / Chain Case – Lubrication	18
Service – Annually.....	18
Engine.....	19
Fuel Filter.....	19
Every Two Years	19
Storage – Out of Season.....	19
Removing Fuel Tank.....	19
SECTION 4- ADJUSTMENTS AND REPAIR	20-28
Engine Adjustments & Repair	20
Mower Deck & Component Adjustments	20
Blade Brake Adjustment	20
Mower Deck Adjustment (Side to Side Levelness)	21
Mower Deck Adjustment (Front to Rear Levelness)	21
Mower Drive Belt Adjustment – 28” & 30” Decks.....	22
Rear Engine Rider Drive Components	23
Service Brake/Park Brake Adjustment	23
Mower Blade Replacement	24
Blade Sharpening	24
Mower Drive Belt Removal/Replacement – 28” 30” & 33” Decks	25
Battery Removal, Replacement, Service	26-28
ACCESSORIES.....	28
TROUBLESHOOTING	29-30
MAINTENANCE SCHEDULE.....	31
MAINTENANCE/REPLACEMENT PARTS.....	32
WARRANTY	33
PRIMARY MAINTENANCE.....	34-37
PRODUCT REGISTRATION FORM	38

Section 1 - FAMILIARIZATION

IMPORTANT: The figures and illustrations in this manual are provided for reference only and may differ from your specific model. Contact your Snapper dealer if you have questions.



FIGURE 1.1

1.1 INTRODUCTION

This manual has been prepared for the operator's of the SNAPPER Rear Engine Rider. Its purpose, aside from recommending standard operating procedures and routine service requirements, is to promote SAFETY through the use of accepted operating practices. **Read, Understand and Follow** the IMPORTANT SAFETY INSTRUCTIONS on Pages 2 thru 4 of this manual and **All SAFETY** messages on the Rear Engine Rider and its attachments before operating.

1.2 NOMENCLATURE

The nomenclature drawing above, Figure 1.1, shows the essential parts of the SNAPPER Rear Engine Rider. It is recommended that all operators of this equipment become thoroughly familiar with the controls, components, and operation of this machine before operating. Specific details involving the engine are found in the separate engine owner's manual. Study these manuals before operating and keep both handy for future reference.

Section 2 - OPERATING INSTRUCTIONS

2.1 PRE-START CHECK LIST

Make the following checks and perform the service required before each start-up.

2.1.1. Check tires and add or release air as needed to bring pressure to 12 PSI in front and 12 PSI in rear tires.

2.1.2. Check guards, deflectors and covers to make sure all are in place and securely tightened.

2.1.3. Check engine oil and add oil as needed to bring level up to the FULL mark. Refer to engine owner's manual for oil specifications. See Figure 2.1.

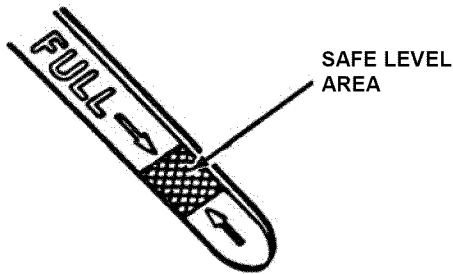

FIGURE 2.1

2.1.4. Adjust seat as needed to most comfortable position. Refer to Section "OPERATOR'S SEAT ADJUSTMENT".

2.1.5. Check blade control to insure it works freely. If blade pedals are depressed, blade lever can be moved manually from "ON" to "OFF" to stop blade.

2.1.6. Check Reverse Lockout Mechanism. With blade pedals depressed, shift lever must not go into reverse.

2.1.7. Clean exterior surfaces of cutting deck and engine of any accumulation of dirt, grass, oil, etc. Keep engine air intake screen and cooling fins clear at all times.

2.1.8. Add fuel to tank after pushing the Rear Engine Rider outside where fumes can dissipate. Make sure fuel filler cap is tight and vent is open after refueling. Refer to engine owner's manual for fuel specifications. See Figure 2.2.

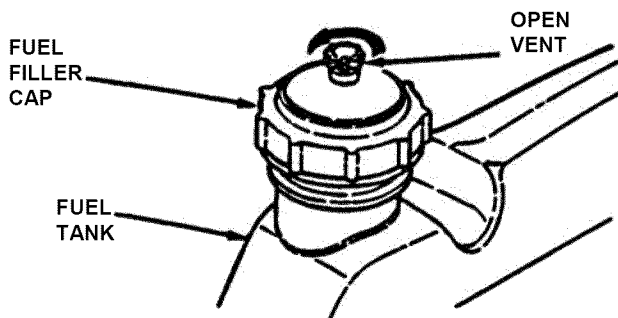

FIGURE 2.2

2.2 OPERATOR'S SEAT ADJUSTMENT

2.2.1. FRONT TO REAR ADJUSTMENT

1. With the engine stopped, loosen the two adjusting knobs and move seat to desired position. After adjustment, tighten knobs securely. If seat does not move after loosening knobs, it may be necessary to loosen the 5/16" patch lock screws or hex nuts located at the rear of the seat. See Figure 2.3.

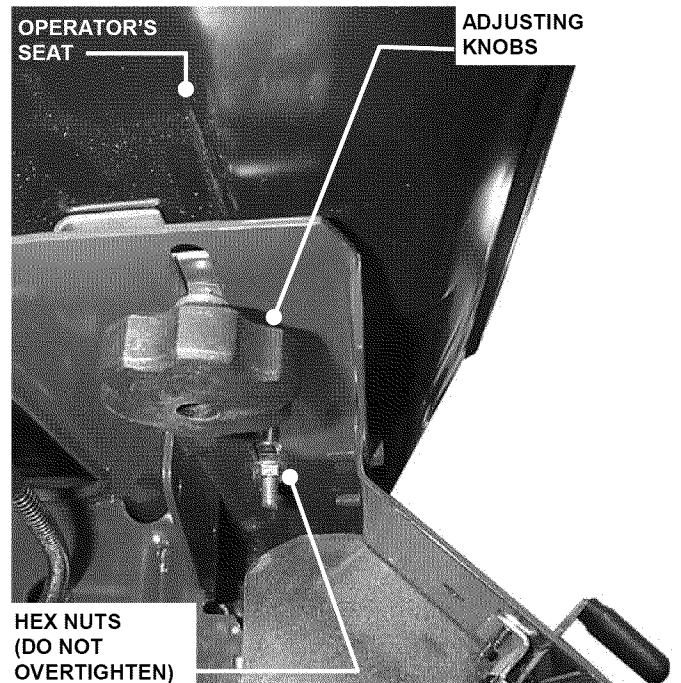
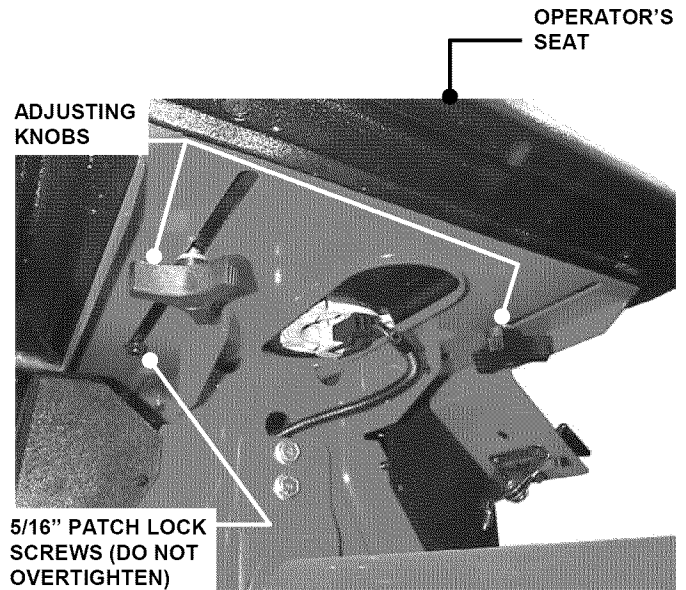

FIGURE 2.3

Section 2 - OPERATING INSTRUCTIONS

2.3 STARTING & OPERATION

2.3.1. ENGINE (ELECTRIC START)

IMPORTANT: When the ignition key is turned to "START", the engine will turn over, but will not start unless the Clutch/Brake pedal is pressed all the way down, the Blade Lever is in the "OFF" position (See Figure 2.5). The operator should be in the seat. Start engine as follows:

1. Move transmission shift lever to (N) Neutral position. **DO NOT** start engine with transmission shift lever in a drive position.



2. Make certain the Blade Lever is in the "OFF" position. See Figure 2.4.

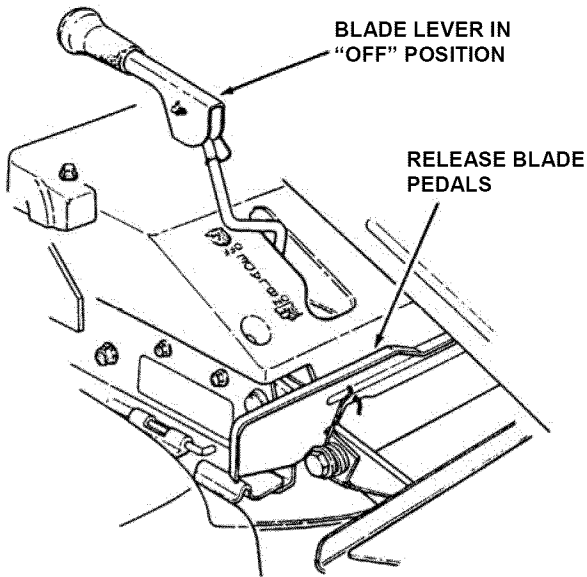

FIGURE 2.4

3. Press Clutch/Brake Pedal all the way down and hold while starting engine. See Figure 2.5.

4. Open vent on fuel filler cap by turning counterclockwise. **IMPORTANT:** Failure to open vent on the fuel filler cap can cause engine to stall. See Figure 2.2.

5. Move engine speed control to the choke position. See Figure 2.6.

6. Turn key to the "START" position until engine starts. See Figure 2.7. **NOTE:** If after 5 seconds of cranking the engine and it does not start, release the key, make sure the Clutch/Brake Pedal is fully depressed and attempt starting again after waiting for approximately 20 seconds.

7. After engine starts, move engine speed control to the "FAST" position, allow a brief warm-up until engine runs smooth.

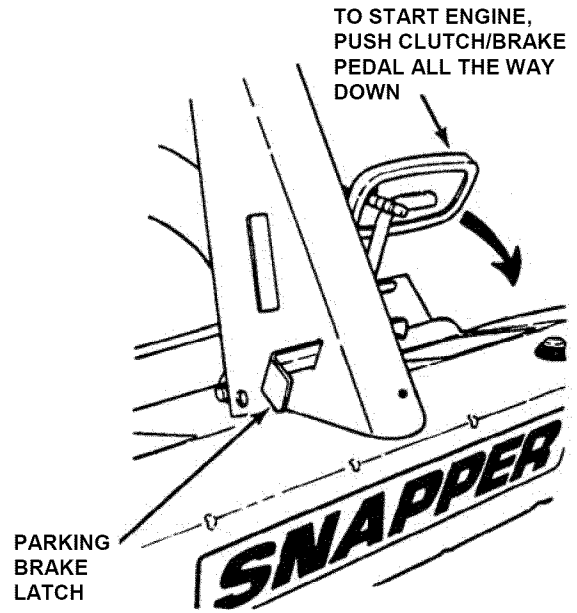

FIGURE 2.5

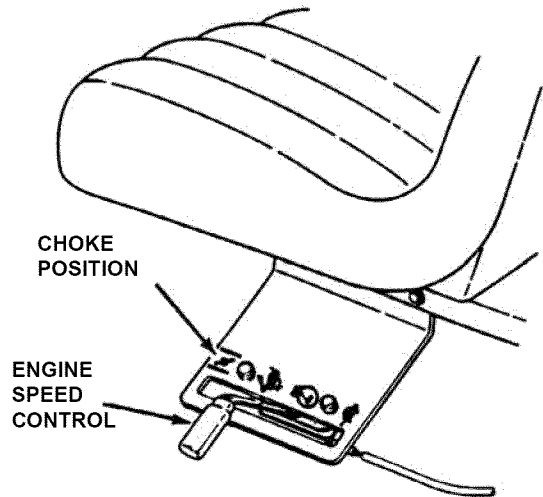

FIGURE 2.6

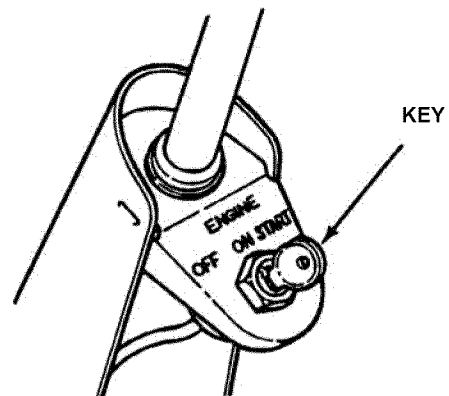

FIGURE 2.7
(Continued on Next Page)

Section 2 - OPERATING INSTRUCTIONS

2.3 STARTING & OPERATION

2.3.1. ENGINE (ELECTRIC START) (Continued)

8. Should the battery be too weak to start the engine, refer to Section "ENGINE (MANUAL START)" to manually start the electric start engines.

9. On Model 3314522BVE, the engine is equipped with a fuel shut-off solenoid. If the battery is dead, the engine can be started with the recoil back-up starter if the throttle control is in the choke position (HOT engine or COLD engine).

2.3.2. ENGINE (MANUAL START)

IMPORTANT: When the ignition key is turned to "ON", and the recoil handle is pulled, the engine will turn over, but will not start unless the Clutch/Brake Pedal is pressed all the way down with Parking Brake engaged (See Figure 2.8) and the Blade Lever is in the "Off" position (See Figure 2.4). Start engine as follows:

1. Move transmission shift lever to (N) Neutral position. **DO NOT** start engine with transmission shift lever in a drive position.

4. Open vent on fuel filler cap by turning counterclockwise. **NOTE:** Failure to open vent on the fuel filler cap can cause engine to stall.

5. Move engine speed control to the choke position to start a cold engine. See Figure 2.6.

6. Turn key to "ON" position. See Figure 2.9.

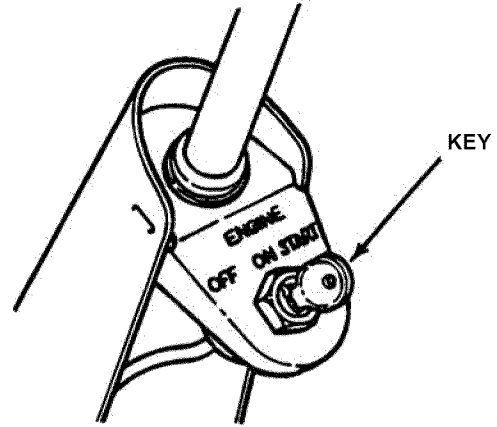

FIGURE 2.9

7. Pull starter rope with a smooth, even motion until engine starts. Always guide the starter rope back into the recoil housing. Never allow rope to snap back. After Engine starts, move engine speed control to the "FAST" position.

8. Allow a brief warm-up until engine runs smooth.

WARNING

It is possible to start engine with transmission shift lever in a drive position. Follow starting instructions carefully.

2. Make certain the Blade Lever is in the "OFF" position. See Figure 2.4.

3. Press Clutch/Brake Pedal all the way down, move Parking Brake Latch over and release the Clutch/Brake Pedal to set Parking Brake. See Figure 2.8.

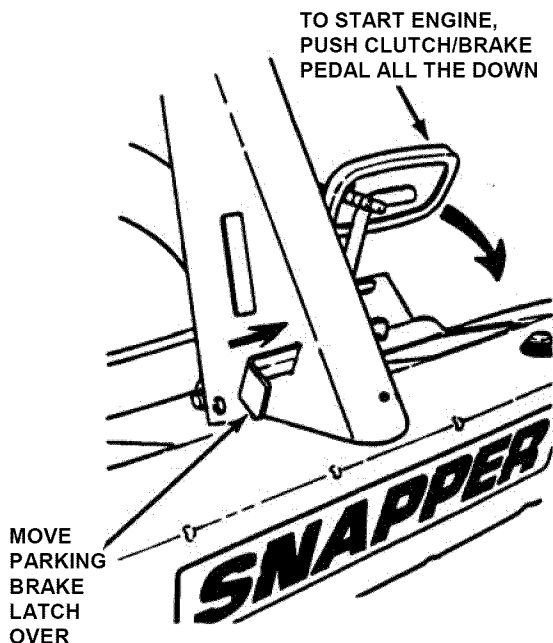

FIGURE 2.8

Section 2 - OPERATING INSTRUCTIONS



WARNING



Once blade is disengaged, it should come to a complete stop in 3 seconds or less. If the blade continues to rotate after 3 seconds, the blade brake must be adjusted. Refer to Section "BLADE BRAKE ADJUSTMENT" for adjustment procedures or return machine to an authorized SNAPPER dealer for adjustment. **DO NOT CONTINUE** to operate machine until blade brake is adjusted and functioning properly.

2.3 STARTING & OPERATION

2.3.3. MOWER BLADE

1. With engine running, move engine speed control to the "FAST" position.
2. Move blade lever forward to the "ON" position, then depress blade pedals to hold blade lever in the "ON" position. See Figure 2.10.

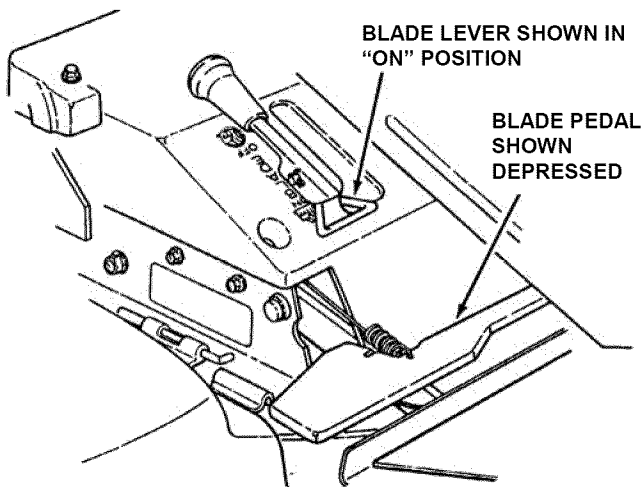

FIGURE 2.10

2.3.4. WHEEL DRIVE

1. With engine running, adjust engine speed control to "FAST" position.
2. Depress clutch/brake pedal. See Figure 2.11.
3. Place transmission shift lever in notch for first speed. See Figure 2.12.
4. Release clutch/brake pedal to begin desired ground speed.
5. During forward motion, the transmission shift lever may be placed in any desired forward speed without depressing the clutch/brake pedal.

NOTE: For best cutting results, move the transmission shift lever into a slow forward speed and the engine speed control to a fast position. This combination will allow the mower blades to lift the grass while cutting smoothly and evenly.



WARNING



DO NOT operate blades in reverse. **STOP BLADES. LOOK and SEE** behind and down for children, pets and hazards before and while backing.

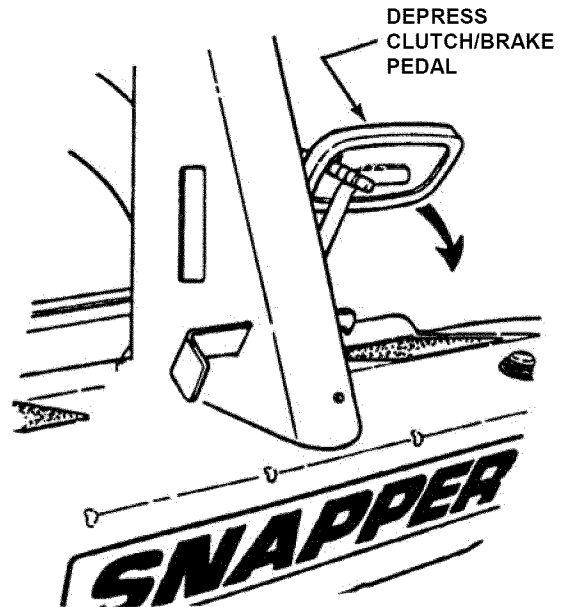

FIGURE 2.11

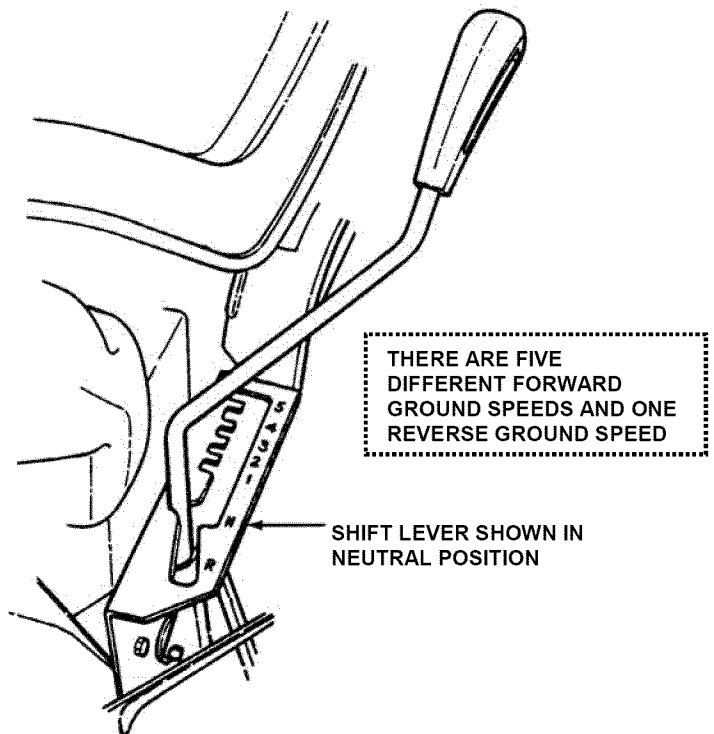

FIGURE 2.12

Section 2 - OPERATING INSTRUCTIONS

WARNING
DO NOT leave the machine with the engine running. STOP Blade. STOP engine. Shift to neutral and engage park brake. Remove key.

2.4 STOPPING - ENGINE, WHEEL DRIVE, BLADE

2.4.1. ENGINE

1. Stop engine by turning key to the "OFF" position. See Figure 2.13.

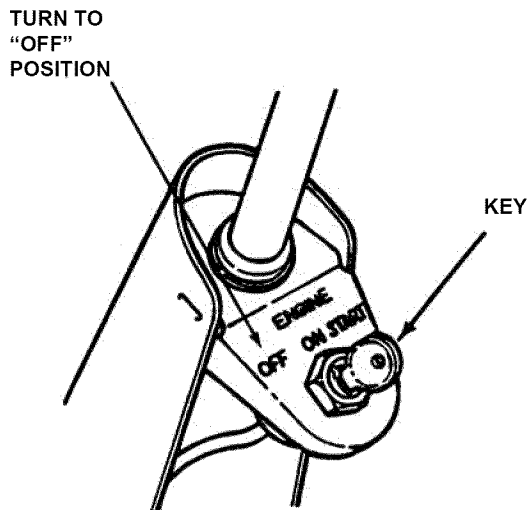

FIGURE 2.13

2.4.2. WHEEL DRIVE

1. Stop motion of Rear Engine Rider by pushing clutch/brake pedal all the way "DOWN" to apply brake. See Figure 2.14.

TO APPLY BRAKES, PUSH CLUTCH/BRAKE PEDAL ALL THE WAY DOWN

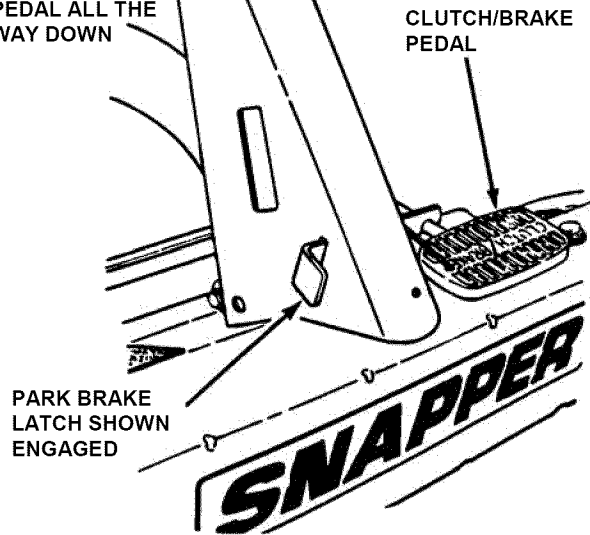

FIGURE 2.14

WARNING
Once blade is disengaged, it should come to a complete stop in 3 seconds or less. If the blade continues to rotate after 3 seconds, the blade brake must be adjusted. Refer to Section "BLADE BRAKE ADJUSTMENT" for adjustment procedures or return machine to an authorized SNAPPER dealer for adjustment. DO NOT CONTINUE to operate machine until blade brake is adjusted and functioning properly.

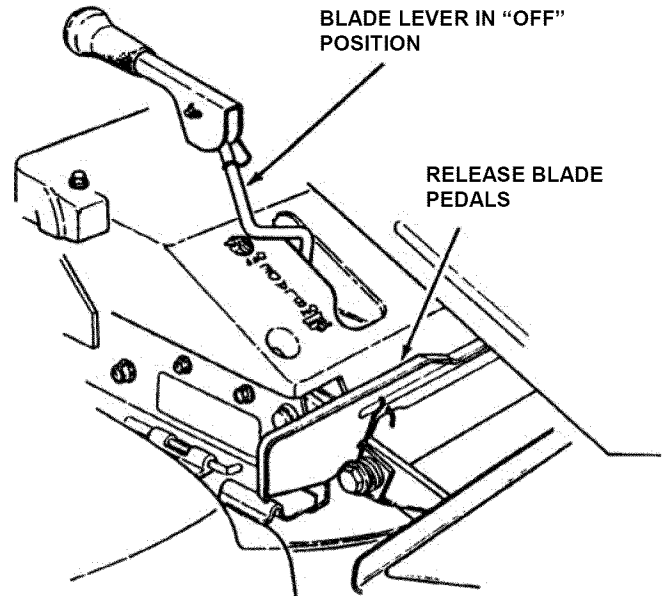

FIGURE 2.15

2.4.3. MOWER BLADE

1. Stop mower blade by releasing blade pedals or moving blade lever rearward to the "OFF" position. See Figure 2.15.

Section 2 - OPERATING INSTRUCTIONS

2.4 STOPPING - ENGINE, WHEEL DRIVE, BLADE

2.4.4. PARK BRAKE

1. Engage park brake by pushing clutch/brake pedal "DOWN" and moving the park brake latch to the "ENGAGED" position. While holding the park brake latch "ENGAGED", release clutch/brake pedal to set park brake. See Figure 2.16.

2.5. CUTTING HEIGHT ADJUSTMENT

1. Adjust cutting height as desired to any one of five positions using deck lift lever. Move deck lift lever up or down to desired cutting height and then move over to secure in the height of cut notch. See Figure 2.18.

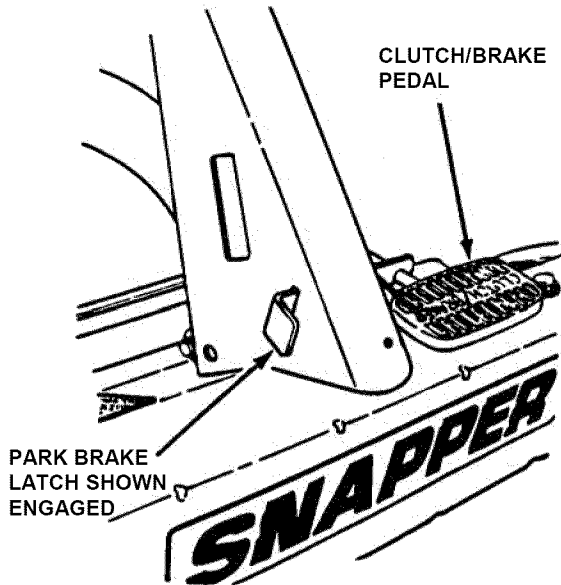

FIGURE 2.16

2. Release park brake by pushing down on the clutch/brake pedal, parking brake latch will move to the "OFF" position unassisted. See Figure 2.17.

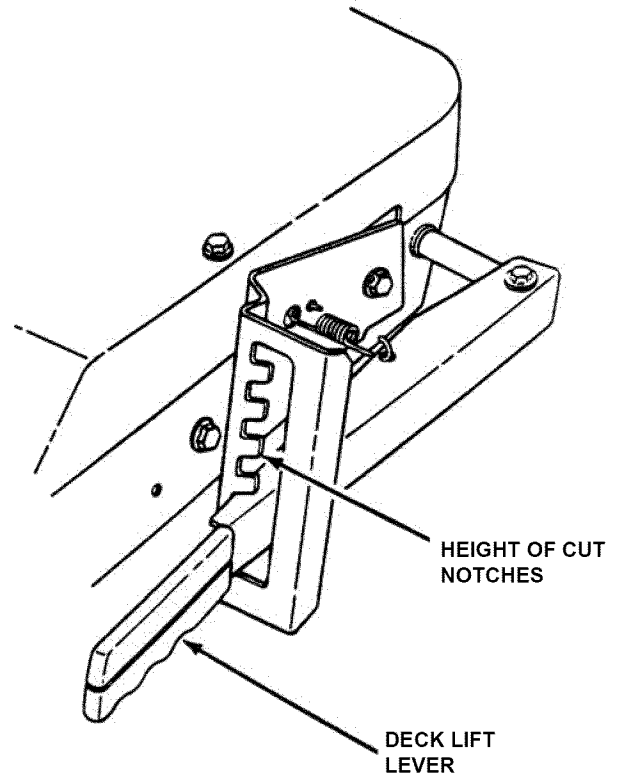

FIGURE 2.18

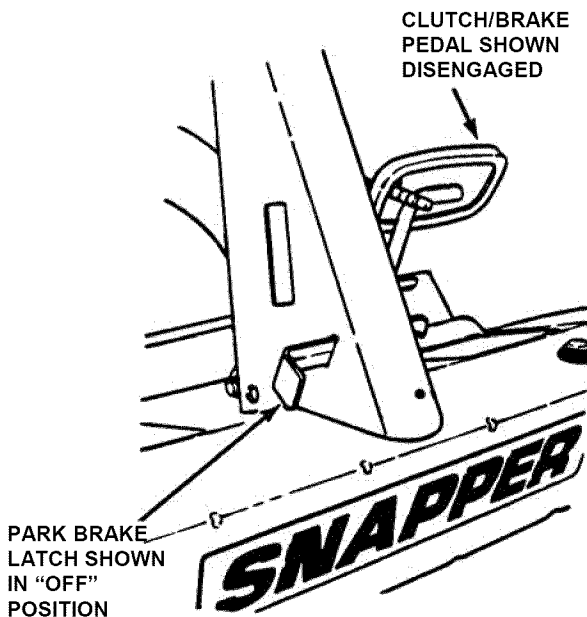

FIGURE 2.17

Section 2 - OPERATING INSTRUCTIONS

2.6 REVERSE LOCKOUT MECHANISM

Data indicates that tragic back-over accidents occur each year. These accidents usually involve unsupervised children. Many times these children have been given rides on the machine and have been trained to view this potentially dangerous piece of machinery as fun rather than being taught how to avoid danger.

This riding mower has a Reverse Lockout Mechanism. This mechanism prevents the mower from being shifted into reverse with the blade running. To shift into reverse you must first stop the blade by releasing the blade pedals and then shift to reverse. It is our recommendation that this mechanism remain functional and the operator of this equipment develop the habit of never backing up with the blade running. As the Safety Instructions Indicate, **DO NOT operate blades in reverse. STOP BLADES, LOOK AND SEE BEHIND AND DOWN for children, pets and hazards before and while backing.**

We realize that this could cause a change to your previous mowing method but we encourage you to adjust to this new system. Do not defeat the Reverse Lockout Mechanism.

If you operate your mower near roadways or use attachments that require quicker shifting to reverse, there is an override lever provided. This lever can be pushed and held before starting the blade and will allow reverse operation until the blade pedals are released, at which time the system will return to its Reverse Lockout mode. This feature should never be selected unless you are absolutely sure that no children or others are present in the mowing area and that all children are away and supervised by a responsible adult.

2.6.1. Reverse Lockout Mechanism Override

1. Stop machine. Stop blade.
2. Depress and hold Override Lever.
3. Depress and hold Blade Pedals. Release Override Lever.
4. Move blade lever forward to "ON" position.



IMPORTANT: DO NOT use the Reverse Lockout Mechanism Override as the normal operating mode. To return to the Reverse Lockout Mechanism mode, release blade pedals to turn blade off. The Override will reset to Reverse Lockout. Check the Reverse Lockout Mechanism frequently for proper function. With the blade pedals depressed, the shift lever must not go into reverse. DO NOT operate machine if Reverse Lockout Mechanism is not functioning properly. Contact your local Snapper dealer for assistance.

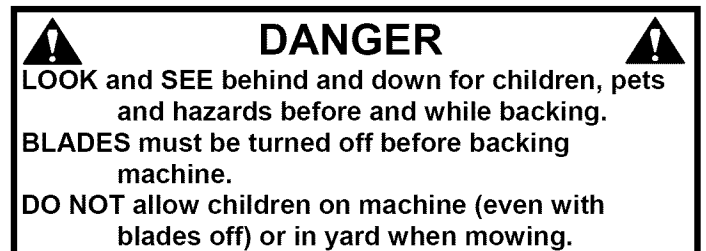
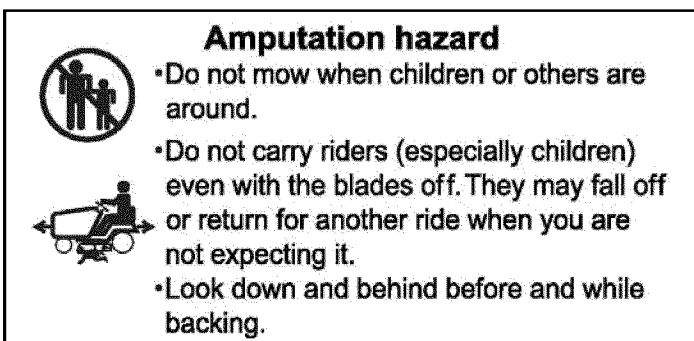

Section 3 – MAINTENANCE

WARNING
DO NOT attempt any adjustments, maintenance, service or repairs with the engine running. STOP engine. STOP blade. Engage parking brake. Remove key. Remove spark plug wire from spark plug and secure away from plug. Engine and components are HOT. Avoid serious burns, allow all parts to cool before working on machine. Fuel Filler Cap and vent must be closed securely to prevent fuel spillage.

3.1 INTRODUCTION

To retain the quality of the Rear Engine Rider, use genuine SNAPPER replacement parts only. Contact a local SNAPPER dealer for parts and service assistance. For the correct part or information for a particular Rear Engine Riding Mower, always mention the model and serial number. SNAPPER recommends returning the Rear Engine Rider to an authorized SNAPPER dealer annually for inspection and addition of any new devices, which might upgrade the safety of the Rear Engine Rider. For the nearest SNAPPER dealer in your area, check the yellow pages under the heading LAWN MOWERS. For engine parts and service, look for the engine manufacturer's dealers under the heading, ENGINES - gasoline.

3.2 SERVICE - AFTER FIRST 5 HOURS

Routine maintenance is important to the performance and life of your Rear Engine Rider. Service performed properly and at the recommended interval is essential. Refer to Section "MAINTENANCE SCHEDULE" in this manual and in the Engine Owner's Manual. Carefully complete all of the recommended service procedures.

3.2.1. CHANGE ENGINE OIL

1. Place bricks or wooden blocks under the front wheels to lower rear of engine.
2. Loosen or remove oil fill cap on engine.
3. Loosen oil drain plug.
4. Place a 2 quart minimum capacity container under the end of the oil drain. Open oil drain. See Figure 3.1 for oil drains used on the Rear Engine Riders.

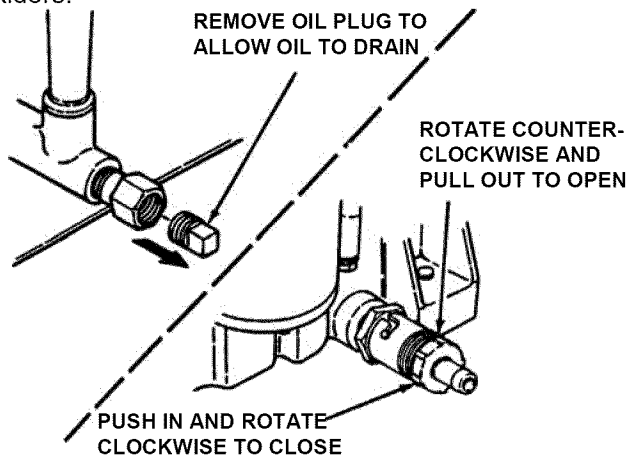

FIGURE 3.1

5. After all the oil has drained, close the drain and wipe up any oil that may have spilled. See Figure 3.1. Dispose of used oil properly.
6. Fill engine crankcase with new oil. Refer to your engine owner's manual for oil specifications.
7. Change oil filter on engines equipped with oil filters at every oil change. Refer to your engine owner's manual for service instructions.

3.2.2. SERVICE ENGINE AIR CLEANER

The engine is equipped with a dual element air cleaner. Both the foam pre-cleaner and cartridge require service. Refer to Engine Owner's Manual for recommended service procedures.

3.2.3. CHECK MOWER BLADE

1. Follow **WARNING** statement found on this page.
2. Check fuel level in tank. If over 3/4 full, remove tank. Refer to Section "REMOVING FUEL TANK". If 3/4 or less, proceed to next step.
3. Carefully stand Rear Engine Rider on rear bumper.

WARNING
Remove the battery if the Rear Engine Rider will be left standing on the rear bumper for longer than 2 hours. Refer to Section "BATTERY REMOVAL". DO NOT use a cutting blade that shows signs of excessive wear or damage on the Rear Engine Rider. Refer to Section "MOWER BLADE REPLACEMENT" for proper blade inspection and service procedures.

4. Check torque of blade mounting bolts. As necessary, torque to 30 to 40 ft. lbs. See Figure 3.2.
5. Check blade for sharpness, wear and damage. Refer to Section "BLADE WEAR LIMITS".

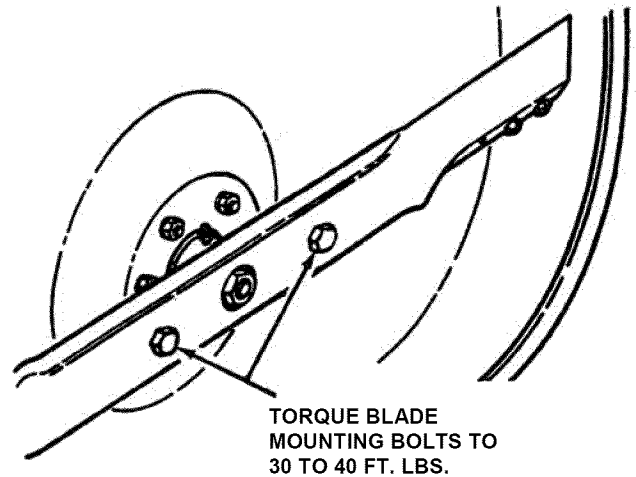

FIGURE 3.2

6. Check blade for straightness. Refer to Section "ADJUSTING MOWER BLADE".

Section 3 - MAINTENANCE

WARNING

DO NOT attempt any adjustments, maintenance, service or repairs with the engine running. STOP engine. STOP blade. Engage parking brake. Remove key. Remove spark plug wire from spark plug and secure away from plug. Engine and components are HOT. Avoid serious burns, allow all parts to cool before working on machine. Fuel Filler Cap and vent must be closed securely to prevent fuel spillage.

3.2 SERVICE - AFTER FIRST 5 HOURS

3.2.4. CHECK BLADE DRIVE BELT

The blade drive consists of a single belt from the engine to the deck. Inspect for signs of deterioration and proper tension.

1. Lower deck to lowest setting.
2. Remove four self-tapping screws, two on each side of mower drive belt cover. See Figure 3.3.
3. Slide cover back and rotate out on left side of mower deck.

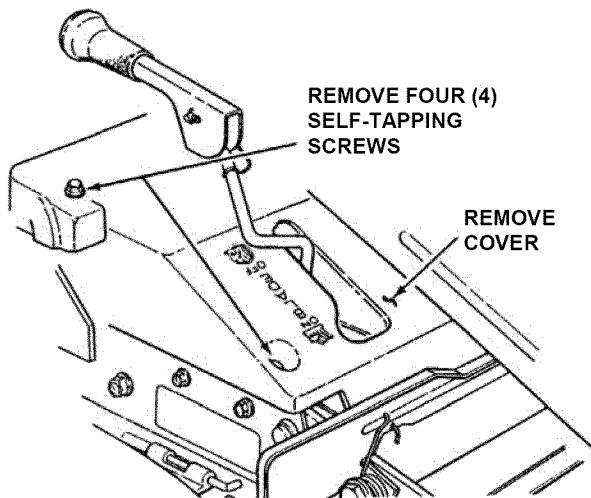

FIGURE 3.3

4. With engine "OFF" and deck in 3rd height of cut position, move blade lever back to the "ON" position and depress blade pedals.

5. **28" and 30" Decks:** Measure the belt spacing at idler pulley. See Figure 3.4. The belt spacing should be 1-1/4" but no less 1". If the measurement is less than 1", the belt tension should be adjusted. Refer to Section "BLADE DRIVE BELT ADJUSTMENT".

WARNING

The following procedure requires the engine and blades to be operated. Exercise extreme caution. Clear area of loose parts & tools first. Only operate blades when seated in the operator's seat.

IMPORTANT: The blade drive belt on 33" decks does not require tension adjustment. If the belt becomes worn or slack it must be replaced. Refer to Section "BLADE DRIVE BELT REPLACEMENT".

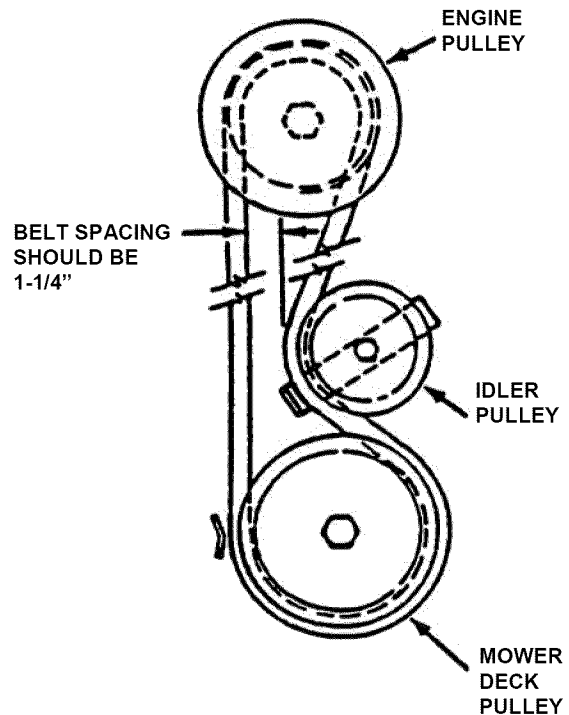

FIGURE 3.4

3.2.5. BLADE BRAKE

1. Check blade brake for proper function. Blade should stop rotating in 3 seconds or less after moving the blade control lever to the "OFF" position or after releasing the blade pedals.

WARNING

Blades must stop rotating in 3 seconds or less after the blade has been turned off. DO NOT operate machine until blade brake has been adjusted and functioning properly.

2. If the blade continues to rotate longer than 3 seconds do not operate machine. Refer to Section "BLADE BRAKE ADJUSTMENT" or contact your SNAPPER dealer for assistance.

3.2.6. SERVICE BRAKE / PARK BRAKE

1. Check machine brake for proper function. Engage park brake. Push machine. Rear tires should skid. Drive machine forward and apply brake. Machine should come to a complete stop in less than 5 ft.

2. If brakes are not functioning properly brake adjustment must be completed before operating machine. Refer to Section "SERVICE BRAKE - PARK BRAKE ADJUSTMENT".

Section 3 – MAINTENANCE

3.2 SERVICE - AFTER FIRST 5 HOURS

3.2.7. SAFETY INTERLOCK SYSTEM CHECKS

Perform the following interlock system checks periodically during the operating season. Contact your authorized Snapper dealer if you have questions.

WARNING

DO NOT operate machine if any safety interlock or safety device is not in place and functioning properly. DO NOT attempt to defeat, modify or remove any safety device.

ENGINE MUST NOT START IF:

- 1) Clutch/Brake Pedal is not fully depressed OR,
- 2) Blade Control is in the "ON" (blades engaged) position.

ENGINE SHOULD START IF:

- 1) Blade Control is in the "OFF" (blades disengaged) position AND,
- 2) Clutch/Brake Pedal is fully depressed.

ENGINE AND BLADES MUST STOP IF:

- 1) Operator rises off of seat with Blade Control in "ON" (blades engaged) position OR,
- 2) Operator rises off of seat with Clutch/Brake Pedal not fully depressed.

3.2.8. REVERSE LOCKOUT MECHANISM

Check function of Reverse Lockout Mechanism with engine off.

1. Depress and hold blade pedals.
2. Depress and hold clutch/brake pedal.
3. Shift lever must not go into reverse.

WARNING

DO NOT operate machine if Reverse Lockout Mechanism is not functioning properly. Contact your SNAPPER dealer immediately for assistance.

3.2.9. LUBRICATION – GREASE FITTINGS

The following components on the Rear Engine Rider are equipped with grease fittings and require periodic lubrication. Apply General Purpose grease (NLGI No.2) with a grease gun.

1. Front Wheel Bearings. Refer to Section "FRONT WHEEL BEARINGS – LUBRICATION".
2. Rear Axle Bearing. Refer to Section "REAR AXLE BEARING – LUBRICATION".
3. Mower Blade Spindle. Refer to Section "MOWER BLADE SPINDLE – LUBRICATION".
4. Shift Lever. Refer to Section "SHIFT LEVER – LUBRICATION".

3.3 SERVICE - EVERY 25 OPERATING HOURS

Perform all service required after the first 5 hours of operation. Refer to Section "SERVICE – AFTER 5 HOURS".

3.3.1. CHECK ENGINE

1. Change engine oil. Refer to Section "CHANGE ENGINE OIL". Refer to engine owner's manual for oil specification.

2. Change air filter. Pull up and rotate the air cleaner latch to remove cleaner cover. See Figure 3.4.

IMPORTANT: When cover is removed, you are viewing the carburetor side of the air filter, which will appear clean. Remove filter and pre-cleaner for inspection.

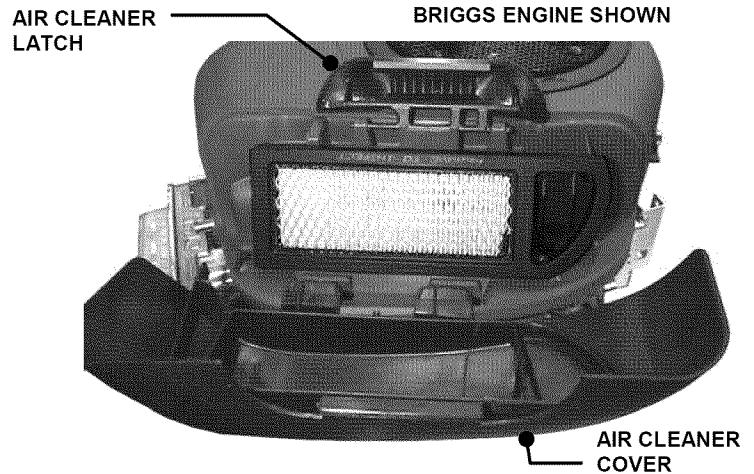

FIGURE 3.4

3. Refer to engine owner's manual for cleaning and service instructions. Remove and clean engine air pre-cleaner. Remove and replace engine air cleaner. See Figure 3.5. Install pre-cleaner and air cleaner per engine owner's manual.

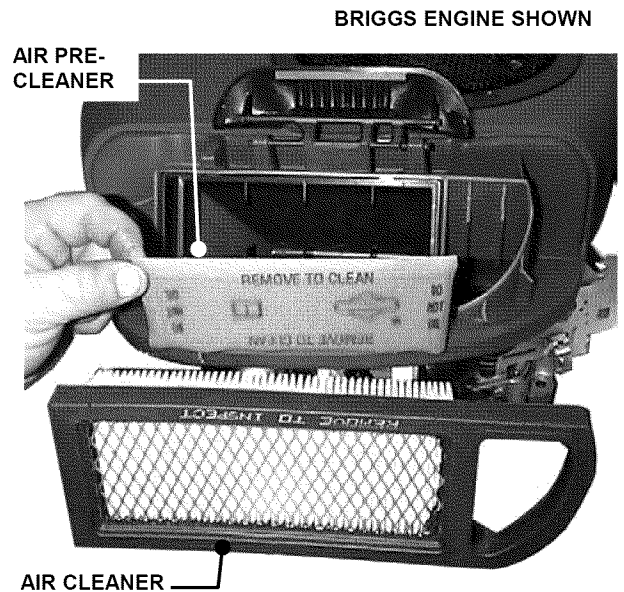



FIGURE 3.5

4. Reinstall air cleaner cover. Insert tabs located at the bottom of the cover into corresponding slots in engine cover. Position cover and engage latch over cover and rotate and push down to lock. **IMPORTANT:** The tabs on the air cleaner cover must be completely inserted into engine cover or the compartment will not be completely sealed to prevent debris from entering into the carburetor.

Section 3 - MAINTENANCE

	WARNING	
<p>DO NOT attempt any adjustments, maintenance or service with the engine or blades running. Stop blades. Stop engine. Engage parking brake. Remove key. Remove spark plug wires from spark plugs and (gas only) secure wires away from spark plugs. Engine and components are HOT. Avoid serious burns by allowing all parts sufficient time to cool. Fuel Filler Cap and Vent must be closed securely to prevent fuel spillage.</p>		

3.3 SERVICE - EVERY 25 OPERATING HOURS

3.3.2. BATTERY FLUID LEVEL

1. Remove battery. Refer to Section "BATTERY REMOVAL".
2. Remove battery caps. Check fluid level.
3. Add water only to bring fluid to proper level – **DO NOT OVERFILL.**
4. Reinstall battery. Refer to Section "BATTERY INSTALLATION".

3.3.3. MOWER DECK LEVELNESS

Check mower deck for proper level. Adjust as required. Refer to Section "MOWER DECK ADJUSTMENT – LEVELNESS".

3.3.4. CLEAN MOWER DECK

1. Follow **WARNING** statement found on this page.
2. Check fuel level in tank. If over 3/4 full, remove tank. Refer to Section "REMOVING FUEL TANK". If 3/4 or less, proceed to next step.
3. Carefully stand Rear Engine Rider on rear bumper.
4. Clean underside of mower deck, removing all accumulation of grass clippings and debris.
5. Clean top of deck, removing all grass clippings and debris.

3.3.5 MOWER BLADE SPINDLE - LUBRICATION

1. Follow **WARNING** statement found on this page.
2. Check fuel level in tank. If over 3/4 full, remove tank. Refer to Section "FUEK TANK REMOVAL". If 3/4 or less, proceed to next step.
3. Carefully stand Rear Engine Rider on rear bumper.
4. Lubricate spindle with three shots of general purpose grease from grease gun. See Figure 3.5.

IMPORTANT: If the Rear Engine Rider will be on its rear bumper for longer than two hours, remove the battery. Refer to Section "BATTERY REMOVAL".

3.3.6. MOWER DECK LINKAGE - LUBRICATION

Lubricate all mower deck linkage pivot points with a light coat of motor oil.

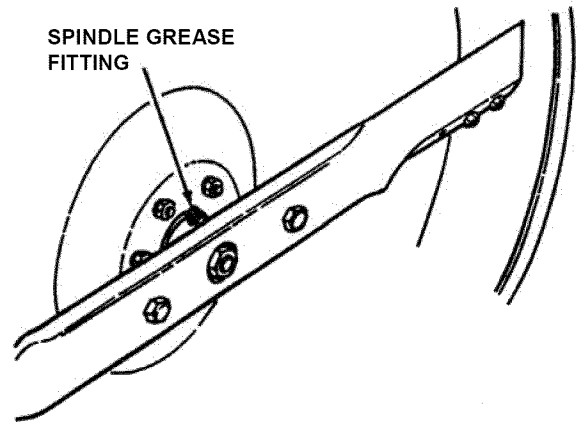

FIGURE 3.5

3.3.7. FRONT WHEEL BEARING - LUBRICATION

1. Lubricate front wheel bearings with five shots of general purpose grease, from grease gun. See Figure 3.6.

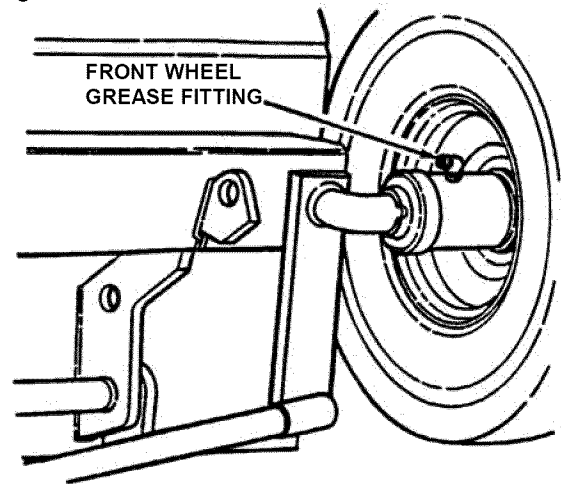

FIGURE 3.6

3.3.7a. SHIFT LEVER - LUBRICATION

1. Lubricate shift lever fitting with two shots of general purpose grease from grease gun. See Figure 3.6a.

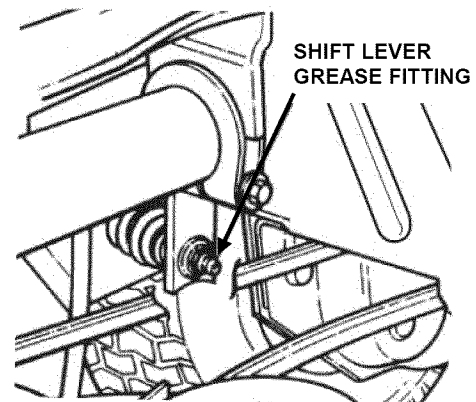

FIGURE 3.6a

Section 3 – MAINTENANCE

WARNING

DO NOT attempt any adjustments, maintenance, service or repairs with the engine running. Stop engine. Stop blade. Engage parking brake. Remove key. Remove spark plug wire from spark plug and secure away from plug. Engine and components are HOT. Avoid serious burns, allow all parts to cool before working on machine. Fuel Filler Cap and Vent must be closed securely to prevent fuel spillage.

3.3 SERVICE - EVERY 25 OPERATING HOURS

3.3.8. REAR AXLE BEARING - LUBRICATION

1. The left rear axle bearing requires three shots of general purpose grease from grease gun. See Figure 3.7.

2. The right rear axle bearing is lubricated by the differential lubricant and requires no grease.

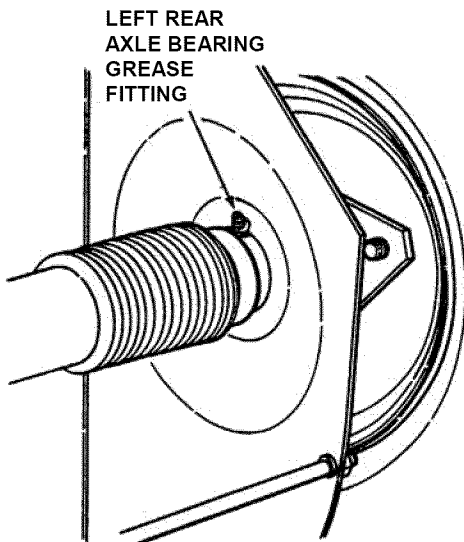

FIGURE 3.7

3.3.9. DIFFERENTIAL/CHAIN CASE - LUBRICATION

1. Stand rear engine rider on its rear bumper and check the fill/level plug, for cracks and wear. Replace fill/level plug if signs of wear are visible.

IMPORTANT: If the Rear Engine Rider will be on its rear bumper for longer than two hours, remove the battery. Refer to Section "BATTERY REMOVAL".

2. To check lubricant, remove fill/level plug and visually inspect for lubricant on the internal parts of the differential. If no lubricant is visible on the internal parts of the differential, add transmission grease as needed. See Figure 3.8.

IMPORTANT: Overfilling of the differential with lubricant will cause lubricant to leak onto drive components of the Rear Engine Rider.

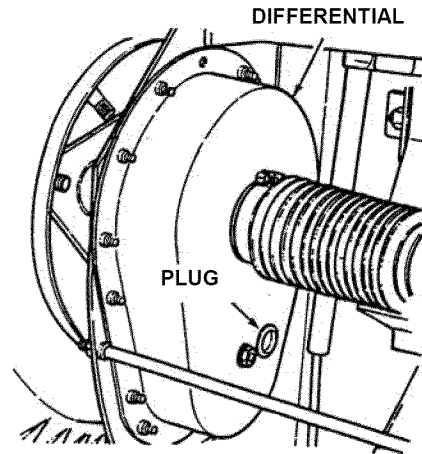

FIGURE 3.8

3. Check fill/level plug for damage. If signs of wear or cracks are visible, replace plug with new plug. See Figure 3.9.

4. To check lubricant in chain case, remove fill/level plug and look for lubricant on the internal components of the chain case. If no lubricant is visible, add SNAPPER transmission grease as needed. See Figure 3.9.

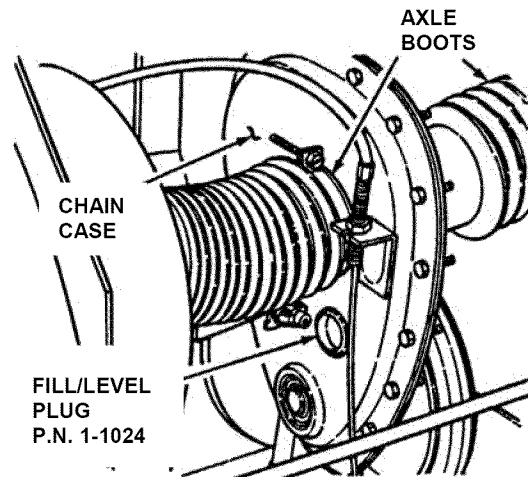

FIGURE 3.9

3.3.10. Check "MAINTENANCE SCHEDULE" Section of Engine Owner's Manual for additional engine service.

Section 3 – MAINTENANCE

WARNING

DO NOT attempt any adjustments, maintenance, service or repairs with the engine running. Stop engine. Stop blade. Engage parking brake. Remove key. Remove spark plug wire from spark plug and secure away from plug. Engine and components are HOT. Avoid serious burns, allow all parts to cool before working on machine. Fuel Filler Cap and Vent must be closed securely to prevent fuel spillage.

3.4 SERVICE - ANNUALLY

3.4.1. ENGINE

1. Perform all maintenance as specified in "MAINTENANCE SCHEDULE" Section of this manual.

3.4.2. FUEL FILTER

Service fuel filter as instructed below, on COLD ENGINE ONLY!

IMPORTANT: To stop flow of fuel, tank may be removed from bracket and set on the floor so the fuel level will be below the filter. Refer to Section "REMOVING FUEL TANK".

1. Remove hose clamps from fuel filter.
2. Remove fuel lines from filter. Discard filter.
3. Install new fuel filter. See Figure 3.10.
4. Reinstall fuel tank into bracket.
5. Carefully reinstall fuel clamps.
6. Check fuel system for leaks.

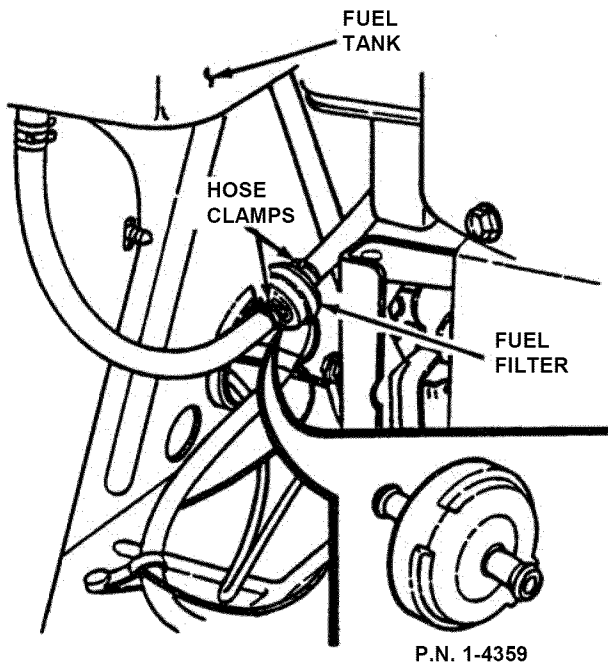

FIGURE 3.10

3.5 EVERY TWO YEARS

In addition to regular maintenance, the following components of the Rear Engine Rider should be carefully inspected every two years for wear or damage. Replace worn or damaged parts with genuine SNAPPER replacement parts available from an authorized SNAPPER dealer.

- 3.5.1. All bushings and pivot areas.
- 3.5.2. Check both front wheel king pins.
- 3.5.3. Transmission shift lever and detent.
- 3.5.4. Clutch disc.
- 3.5.5. Clutch Yoke.
- 3.5.6. Mower deck linkage and pivot areas.

3.6 STORAGE (OUT OF SEASON)

If desired, the Rear Engine Rider can be stored on the rear bumper. Perform the following procedures to insure the Rear Engine Rider will operate properly when taken out of storage.

- 3.6.1. Thoroughly clean the Rear Engine Rider by removing all grass clippings and debris.
- 3.6.2. Perform maintenance and lubrication as required.
- 3.6.3. Drain fuel from fuel tank.
- 3.6.4. Start engine and allow it to run until engine runs out of fuel. This allows the carburetor and fuel system to remain clean during storage.
- 3.6.5. Remove battery. Refer to Section "BATTERY STORAGE".
- 3.6.6. Close vent on fuel filler cap.
- 3.6.7. Carefully stand Rear Engine Rider on rear bumper in desired location for storage.

3.7 REMOVING FUEL TANK

Before removing fuel tank from rear engine rider, move rider outdoors where fumes can be easily dissipated. Removal of the tank is accomplished from the left side of the machine by pulling the tank straight up and away from the fuel tank bracket. Holding the fuel tank, remove the fuel filler cap and pour remaining fuel in an approved container. See Figure 3.11.

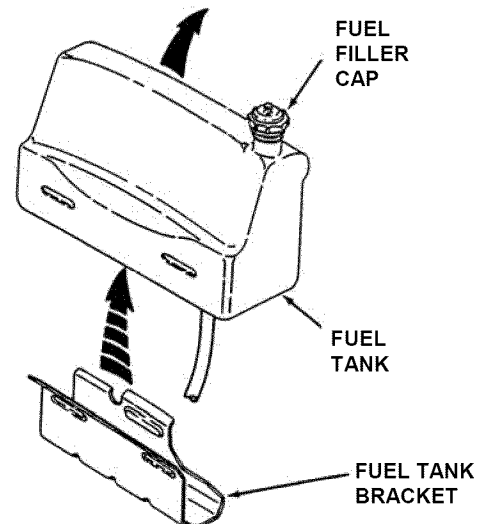

FIGURE 3.11

Section 4 - ADJUSTMENTS & REPAIR

WARNING
DO NOT attempt any adjustments, maintenance, service or repairs with the engine running. Stop engine. Stop blade. Engage parking brake. Remove key. Remove spark plug wire from spark plug and secure away from plug. Engine and components are HOT. Avoid serious burns, allow all parts to cool before working on machine. Fuel Filler Cap and Vent must be closed securely to prevent fuel spillage.

4.1 ENGINE ADJUSTMENTS & REPAIR

Refer to the engine owner's manual for those adjustments and/or repairs that can be made by the owner.

4.2 MOWER DECK & COMPONENT ADJUSTMENTS

The following mower deck and component adjustments and repairs can be made by the owner. However, if there is difficulty in achieving these adjustments and repairs, it is recommended that these repairs be made by an authorized SNAPPER dealer.

WARNING
Once blade is disengaged it should come to a stop in 3 seconds or less. If the blade continues to rotate after 3 seconds the blade brake must be adjusted. DO NOT continue to operate the machine if the blade brake is not operating properly.

4.2.1. BLADE BRAKE ADJUSTMENT

The automatic Blade Brake should stop the blades within 3 seconds anytime the blades are disengaged by moving blade lever to the "OFF" position or by releasing the Blade Pedals. When the Blade Brake is properly adjusted there should be 3" to 3-1/4" clearance between the Blade Engagement Lever and the edge of the Latch Plate. Check this by disengaging the Blade Lever as shown in Figure 4.1. Perform the following measurement and adjustment.

1. With the blade engagement lever disengaged, measure the distance between the front of the blade lever and the edge of the latch plate. The dimension should be 3" to 3-1/4" clearance between lever and edge of plate. See Figure 4.1. If the dimension is incorrect go to step 2.
2. Remove Belt Cover. Refer to Section "BLADE BELT COVER REMOVAL".
3. If dimension is greater than 3-1/4", rotate nut clockwise to increase brake tension. If dimension is less than 3", rotate nut counter-clockwise to decrease brake tension. See Figure 4.2.
4. Reinstall belt cover and tighten bolts securely.

WARNING
DO NOT operate machine until blade brake is adjusted and functioning properly. If blade stop time can not be achieved with the adjustment procedure described above, take machine immediately to an authorized Snapper dealer.

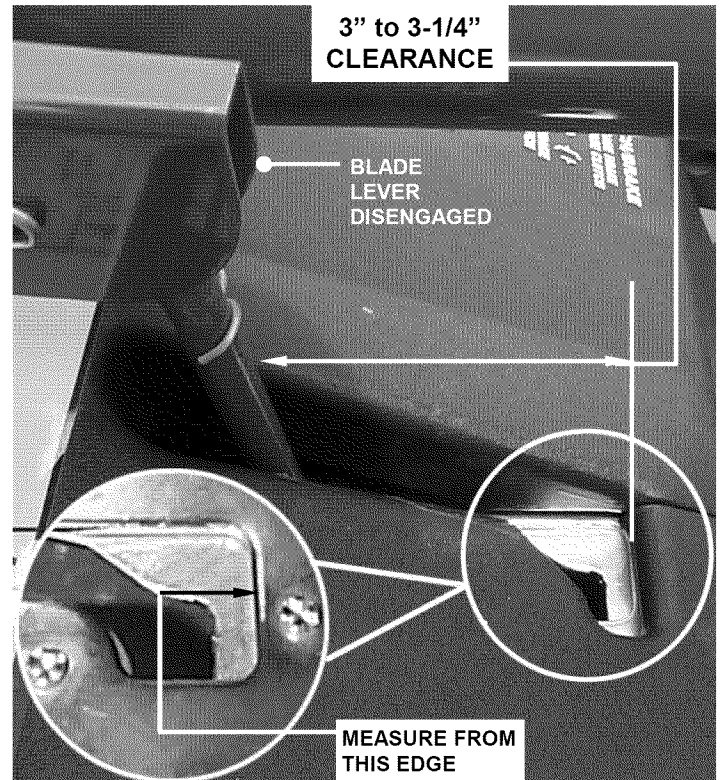

FIGURE 4.1

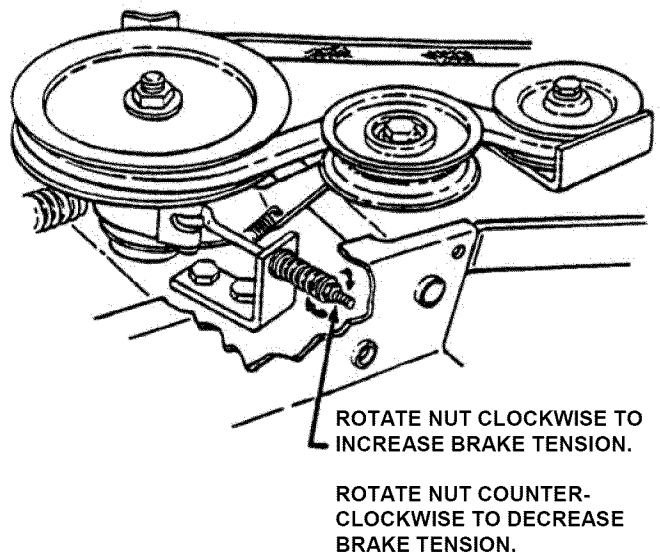

FIGURE 4.2

(Continued on Next Page)

Section 4 - ADJUSTMENTS & REPAIR

WARNING

DO NOT attempt any adjustments, maintenance, service or repairs with the engine running. STOP engine. STOP blade. Engage parking brake. Remove key. Remove spark plug wire from spark plug and secure away from plug. Engine and components are HOT. Avoid serious burns, allow all parts to cool before working on machine. Fuel Filler Cap and vent must be closed securely to prevent fuel spillage.

4.2.2. MOWER DECK ADJUSTMENT (Side-To-Side Levelness)

Before making deck leveling adjustments, check the tire pressure. Front tires 12 PSI, rear tires 12 PSI. If tires are properly inflated and mowing is still uneven, adjust side-to-side deck levelness.

1. Place Rider on a smooth level surface.
2. Turn engine off and remove key, remove spark plug wire from spark plug and secure wire away from plug.
3. Place a piece of angle iron, pipe, or similar object under center of deck at the rear.
4. Remove rear hanger chains and allow center, rear of deck to rest on angle iron.
5. Measure the distance from blade tips to floor. If the measurement is within 1/8" from side-to-side, the deck attitude is satisfactory. If difference from side-to-side is greater than 1/8", continue with adjustment.
6. Loosen the shoulder bolt & nut that retains the left side of blade pedal. See Figure 4.3.

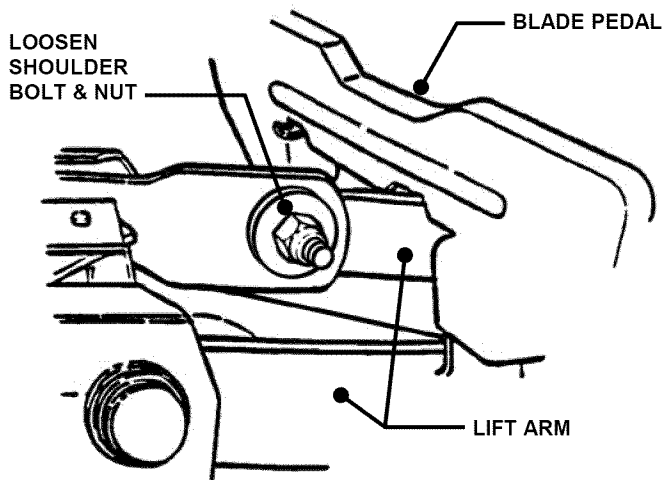

FIGURE 4.3

7. Move lift arm up or down as required until blade tips are within 1/8" of each other. See Figure 4.3.
8. Tighten shoulder bolt & nut loosened in Step 6. Recheck both sides of deck for correct levelness.
9. Readjust rear hanger chain pivots to align with holes in support brackets. See Figure 4.4.
10. Remove angle iron, pipe, or similar object and proceed to check front to rear levelness.

4.2.3. MOWER DECK ADJUSTMENT (Front to Rear Levelness - 28", & 33" Decks)

With the Rear Engine Rider on a smooth, level surface, rotate blade until blade tips are at front and rear of deck. Measure the distance from blade tips to floor. The distance should be the same, or the rear 1/8" to 1/4" lower than the front. If the rear blade tip is higher or is more than 1/4" lower than the front, proceed with adjustment. Go to Step 1.

(Front to Rear Levelness - 30" Decks)

With the Rear Engine Rider on a smooth, level surface, rotate blade until blade tips are at front and rear of deck. Measure the distance from blade tips to floor. The distance should be the same, or the rear 1/8" to 1/4" higher than the front. If the rear blade tip is lower or is more than 1/4" higher than the front, proceed with adjustment. Go to Step 1.

1. Remove rear hanger chains.
2. Turn each hanger pivot the same number of rotations on the eye-bolt to raise or lower the rear of the deck. See Figure 4.4.
3. Reinstall rear hanger chains and measure blade tips again.
4. Repeat steps "1" through "3" until proper levelness is obtained.

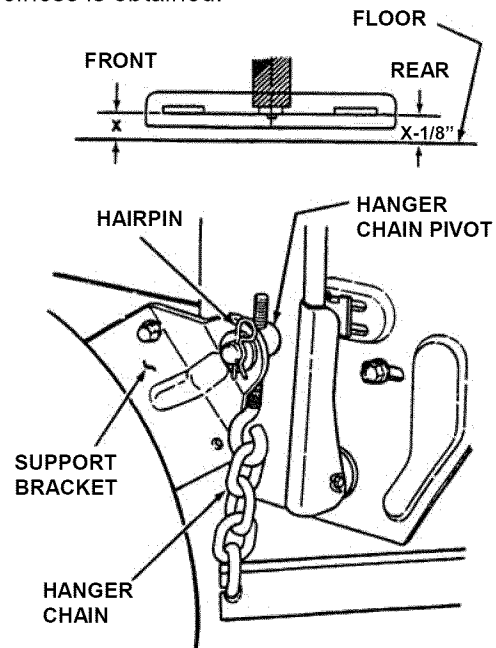

FIGURE 4.4

Section 4 - ADJUSTMENTS & REPAIR

WARNING
DO NOT attempt any adjustments, maintenance, service or repairs with the engine running. STOP engine. STOP blade. Engage parking brake. Remove key. Remove spark plug wire from spark plug and secure away from plug. Engine and components are HOT. Avoid serious burns, allow all parts to cool before working on machine. Fuel Filler Cap and vent must be closed securely to prevent fuel spillage.

4.2.4. MOWER DRIVE BELT ADJUSTMENT (FOR 28" & 30" DECKS ONLY)

1. Remove mower drive belt cover. Refer to Section "CHECK MOWER DRIVE BELT".
2. Move blade lever up and over to the "ON" position.
3. Place deck cutting height in the 3rd position. Measure the belt spacing between idler pulley and belt. The distance should measure 1-1/4" but no less than 1". See Figure 4.5.

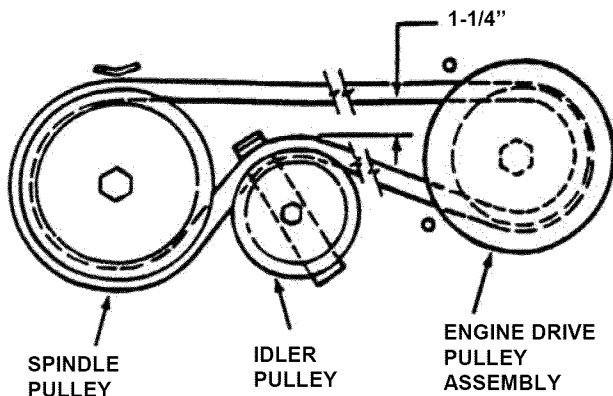

FIGURE 4.5

4. If the distance is less than 1", adjust belt tension.
5. Move blade lever to the "OFF" position.
6. Loosen hardware that secures the clamp that anchors the front frame assembly to the rear main case. See Figure 4.6.
7. Pull front frame forward until belt spacing, with blade lever "ON", measures 1-1/4".
8. Retighten hardware that secures clamp. Make sure hardware is tightened securely.

IMPORTANT: The SNAPPER Rear Engine Rider Models with 33" decks do not require belt tension adjustment. But, if front frame assembly clamp is loosened for any reason, recheck belt spacing between idler pulley and belt. With blade lever in the "ON" position, the distance should measure 1-3/4".

9. When belt adjustment is complete it will be necessary to check Clutch/Brake Cable slack.
10. Disengage parking brake and allow pedal to remain in the engaged wheel drive (Up) position. See Figure 4.7.
11. Clutch/Brake Cable should have approximately 3/16" of slack. If the cable does not have slack adjustment of cable must be performed.

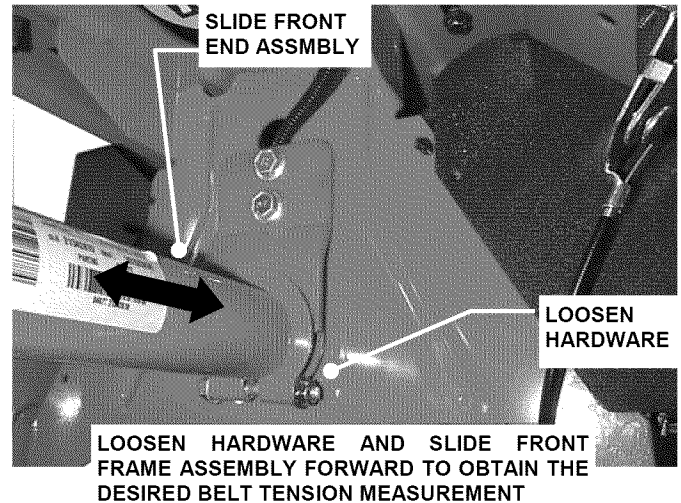

FIGURE 4.6

12. Peel back the rubber clutch/brake pedal pad and push one ferrule through hole in pedal to attain slack in cable. See Figure 4.7. Recheck cable for the approximate 3/16" of slack. Replace pedal pad when adjustment is complete.

IMPORTANT: Too much slack may cause improper clutching and braking could be affected. Too little slack may cause improper clutch function. Recheck service brake/park brake and readjust if necessary. Refer to Section "SERVICE BRAKE/PARK BRAKE ADJUSTMENT".

PEEL BACK PEDAL PAD. PUSH ONE FERRULE THROUGH PEDAL. RECHECK CABLE SLACK

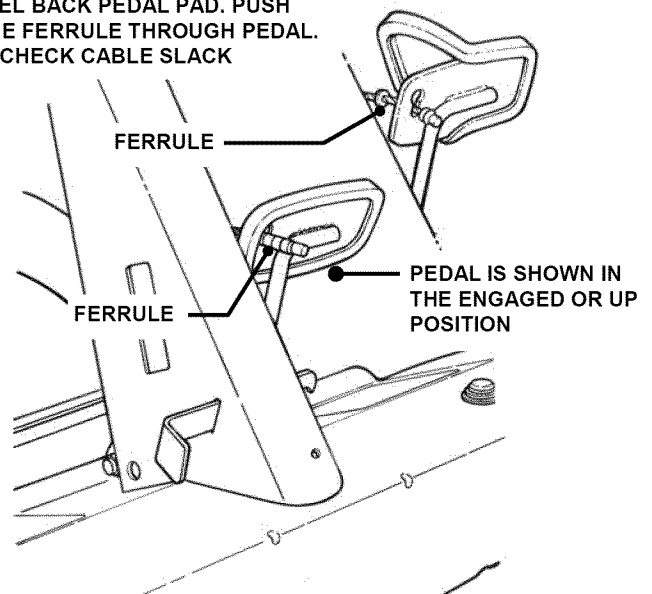

FIGURE 4.7

Section 4 - ADJUSTMENTS & REPAIR

WARNING

DO NOT attempt any adjustments, maintenance, service or repairs with the engine running. **STOP** engine. **STOP** blade. Engage parking brake. Remove key. Remove spark plug wire from spark plug and secure away from plug. Engine and components are **HOT**. Avoid serious burns, allow all parts to cool before working on machine. Fuel Filler Cap and vent must be closed securely to prevent fuel spillage.

4.3 REAR ENGINE RIDER DRIVE COMPONENTS

Your Snapper rider is equipped with a patented smooth start clutch. The clutch should operate smoothly and provide ample traction. If problems are experienced, contact your Snapper dealer for repair.

4.3.1 SERVICE BRAKE/PARK BRAKE ADJUSTMENT

Test the wheel brake on a dry concrete surface. When properly adjusted, the Rear Engine Rider will stop within 5 feet from fastest speed. If stopping distance is more than 5 feet, the wheel brake should be adjusted as follows:

1. Follow **WARNING** statement found on this page. Check fuel level in tank. Refer to Section "REMOVING FUEL TANK". If over 3/4 full, remove tank.
2. If 3/4 or less, proceed to next step.
3. Carefully stand Rear Engine Rider on rear bumper.
4. Depress clutch/brake pedal all the way down. Move and hold the park brake lever in the "ON" position and release the clutch/brake pedal to lock the park brake. See Figure 4.8.

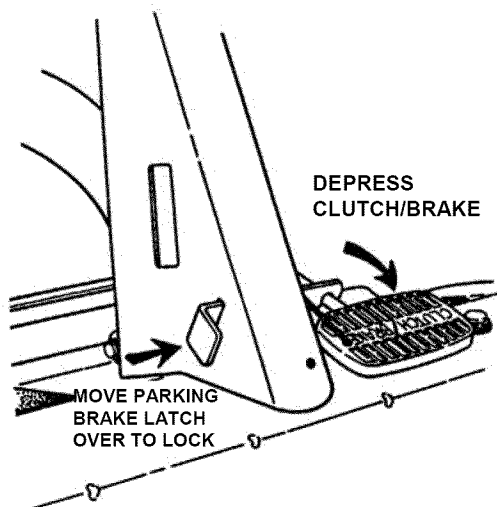

FIGURE 4.8

5. Measure the distance between end of clutch/brake cable and bottom of housing. Measurement should be 3/4". See inset of Figure 4.9.

6. If measurement is not 3/4", loosen the two jam-nuts. See Figure 4.10. Hold the clutch/brake cable to the chain case bracket.

7. Adjust cable up or down using the jam-nuts to obtain a distance of 3/4" between end of clutch/brake cable and bottom of housing. See Figure 4.9.

8. After adjustment is complete, securely tighten cable jam-nuts.

9. Retest wheel brake.

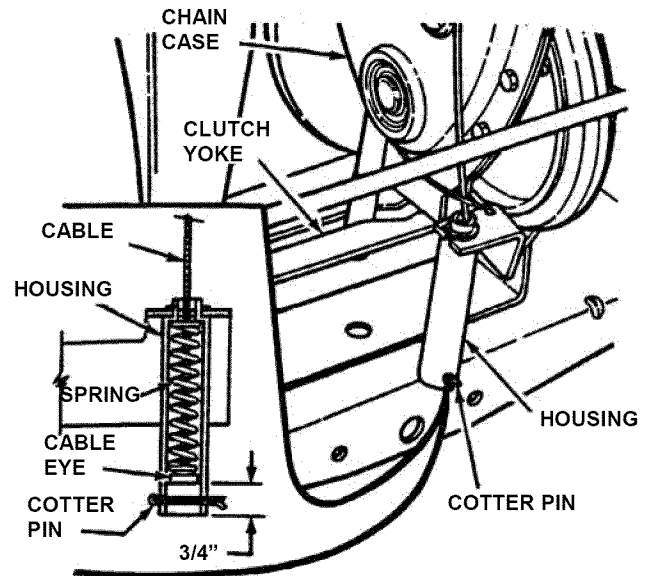

FIGURE 4.9

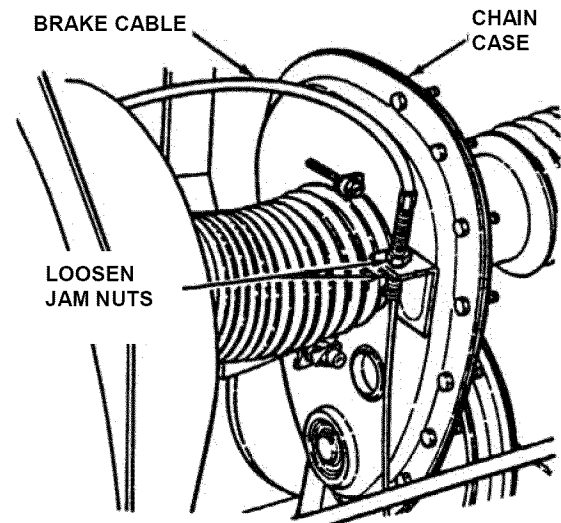

FIGURE 4.10

Section 4 - ADJUSTMENTS & REPAIR

WARNING

DO NOT attempt any adjustments, maintenance, service or repairs with the engine running. Stop engine. Stop blade. Engage parking brake. Remove key. Remove spark plug wire from spark plug and secure away from plug. Engine and components are HOT. Avoid serious burns, allow all parts to cool before working on machine. Fuel Filler Cap and Vent must be closed securely to prevent fuel spillage. DO NOT use a cutting blade that shows signs of excessive wear or damage. On Rear Engine Riders equipped with a grass catcher attachment, the air lifts should be replaced when the blade is replaced.

4.4 MOWER BLADE REPLACEMENT

4.4.1. BLADE WEAR LIMITS

1. Inspect blade frequently for signs of excessive wear or damage. See Figure 4.11.

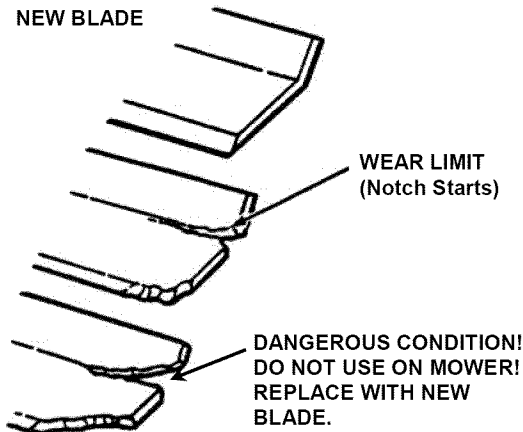

FIGURE 4.11

WARNING

Wear heavy leather gloves when handling or working around cutting blades. Blades are extremely sharp and can cause severe injury. DO NOT use a cutting blade that shows signs of excessive wear or damage.

4.4.2. BLADE SHARPENING

1. Follow **WARNING** statement found on this page.
2. Check fuel level in tank. If over 3/4 full, remove tank. Refer to Section "REMOVING FUEL TANK". If 3/4 or less, proceed to next step.
3. Carefully stand Rear Engine Rider on rear bumper.
4. Remove blade. See Figure 4.12.

5. Inspect condition of blade. See Figure 4.11.
6. If blade is in good condition, sharpen at 22 to 28 degrees. DO NOT sharpen beyond existing cutting edge. See Figure 4.13.
7. Check blade balance after sharpening. If necessary, correct blade balance by grinding the heavy end of blade.
8. Reinstall blade. See Figure 4.12. Torque blade mounting bolts to recommended range of 30 to 40 ft. lbs.

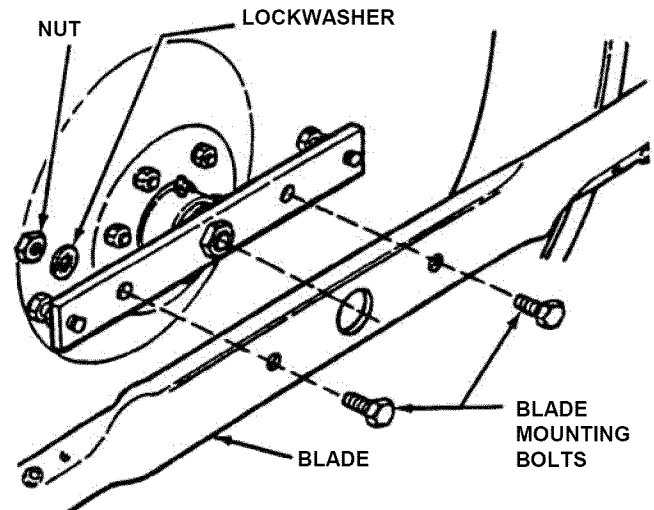

FIGURE 4.12

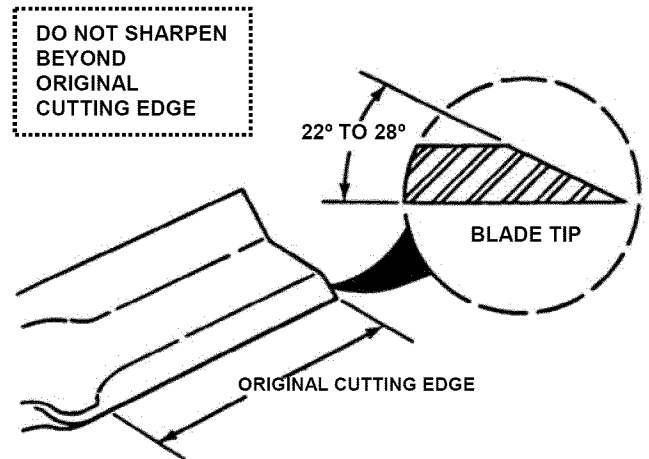

FIGURE 4.13

Section 4 - ADJUSTMENTS & REPAIR

WARNING

DO NOT attempt any adjustments, maintenance, service or repairs with the engine running. STOP engine. STOP blade. Engage parking brake. Remove key. Remove spark plug wire from spark plug and secure away from plug. Engine and components are HOT. Avoid serious burns, allow all parts to cool before working on machine. Fuel Filler Cap and vent must be closed securely to prevent fuel spillage.

4.5 MOWER DRIVE BELT REPLACEMENT

Inspect mower drive belt as described in Section "CHECK MOWER DRIVE BELT". Replace belt if signs of excessive wear and/or damage are present.

4.5.1. BELT REMOVAL

1. Remove mower drive belt cover. Refer to Section "DRIVE BELT COVER REMOVAL".
2. Remove old belt.

4.5.2. BELT REPLACEMENT

1. Follow **WARNING** statement found on this page.
2. Check fuel level in tank. If over 3/4 full, remove tank. Refer to Section "REMOVING FUEL TANK". If 3/4 or less, proceed to next step.
3. Carefully stand Rear Engine Rider on rear bumper.
4. Route new belt through engine belt guide up to engine pulley. See Figure 4.14.

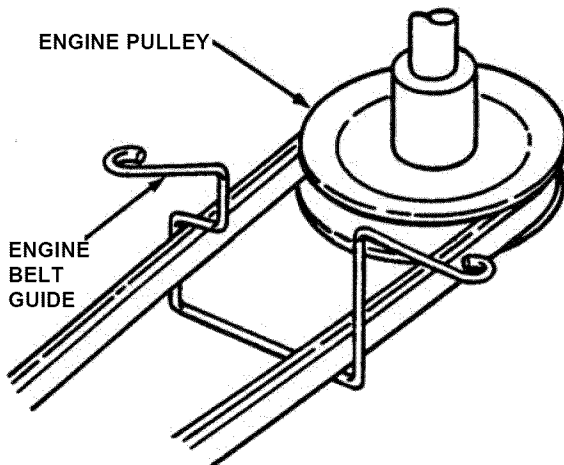

FIGURE 4.14

5. Move transmission shift lever to the neutral (N) position.
6. Rotate clutch yoke (clutch yoke shown in Figure 4.9) out with your hand and work belt between drive disc and rubber driven disc.
7. To clear the primary chain case, move transmission shift lever to the #5 position. Route belt around drive disc and into drive pulley belt groove.
8. Remove idler. See Figure 4.15 and 4.16.

9. Route belt onto spindle pulley. Make sure belt is inside spindle belt guide and idler belt guide. Route belt as shown in Figure 4.15 or 4.16.

10. Reinstall idler removed in Step 8. The idler belt guide tab should be positioned in the hole located on idler arm. Tighten idler pulley bolt securely.

11. Adjust belt guide. See Figure 4.15 or 4.16 for proper belt-to-belt guide clearances.

12. Check mower drive belt tension and adjust if necessary (28" & 30" decks only). Refer to Section "MOWER DRIVE BELT ADJUSTMENT".

13. Reinstall mower drive belt cover.

28" & 30" DECKS

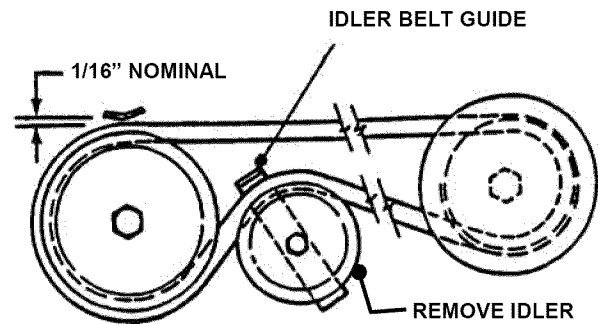

FIGURE 4.15

33" DECKS

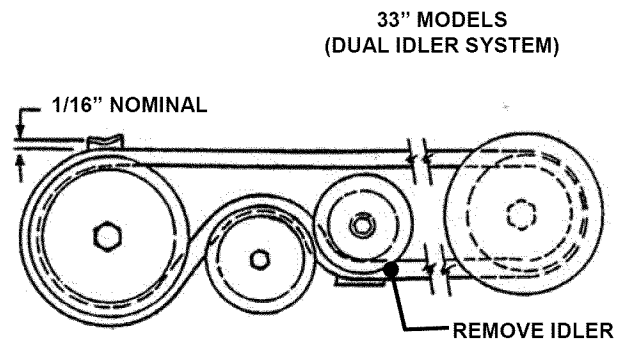

FIGURE 4.16

Section 4 - ADJUSTMENTS & REPAIR

WARNING

DO NOT attempt any adjustments, maintenance, service or repairs with the engine running. Stop engine. Stop blade. Engage parking brake. Remove key. Remove spark plug wire from spark plug and secure away from plug. Engine and components are HOT. Avoid serious burns, allow all parts to cool before working on machine. Fuel Filler Cap and Vent must be closed securely to prevent fuel spillage. DO NOT attempt to service or charge the battery while it is installed on the machine.

4.6 BATTERY

4.6.1. BATTERY REMOVAL

1. Carefully pull each side of battery cover away from ratchet fasteners and remove cover. See Figure 4.17.

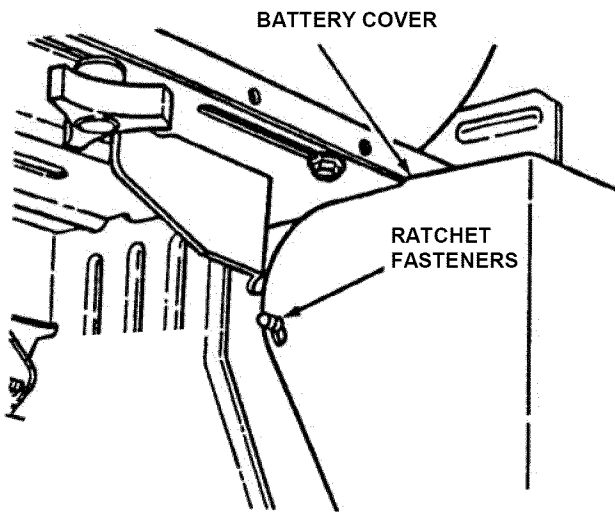

FIGURE 4.17

2. Remove the hair pin and swivel from the deck support to allow clearance for battery removal.
3. Slide battery from battery box to gain access to terminal cables.
4. Observe and note cable positions on battery. See Figure 4.18.
5. Disconnect cables from battery terminals, disconnecting BLACK (Negative) cable first. Retain mounting bolts and nuts.

CAUTION

If battery is removed, DO NOT operate engine without insulating Positive + battery cable terminal with electrical tape, or sparking from battery cables can result.

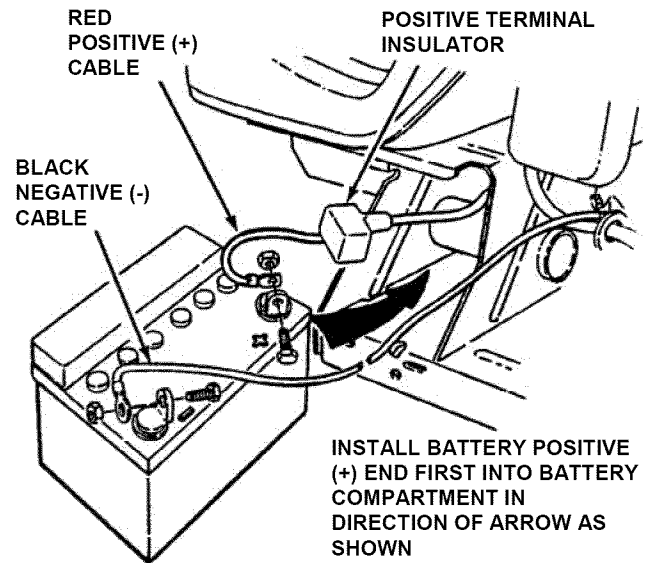

FIGURE 4.18



WARNING

Cables must be connected to battery terminals in the proper position as show in Figure 4.18. DO NOT attempt to charge battery while installed on the Rear Engine Rider. DO NOT use "BOOST" chargers on the battery.

4.6.2. BATTERY INSTALLATION

1. Slide battery partially into battery housing.
2. Connect positive (+) cable (red) first, from wiring harness to the positive terminal (+) on battery using bolt and nut provided in hardware bag. Connect negative (-) cable (black) last, to negative terminal (-) on battery using bolt and nut. Apply a small amount of grease over terminals to prevent corrosion.
3. Reinstall positive terminal insulator.
4. Insert battery completely into battery housing.
5. Reinstall battery cover. See Figure 4.17.
6. Reinstall swivel and hair pin for deck support.

Section 4 - ADJUSTMENTS & REPAIR

 **WARNING** 
The electrolyte (acid) produces a highly explosive gas. Keep all sparks, flame and fire away from area when charging battery or when handling electrolyte or battery. Electrolyte (acid) is a highly corrosive liquid. Wear eye protection. Wash affected areas immediately after having eye or skin contact with electrolyte (acid). Battery acid is corrosive. Rinse empty acid containers with water and mutilate before discarding. If acid is spilled on battery, bench, or clothing, etc., Flush with clear water and neutralize with baking soda. **DO NOT attempt to charge battery while installed on the RIDER. DO NOT use "BOOST" chargers on the battery.**

4.6.3. BATTERY SERVICE

1. Remove battery. Refer to Section "BATTERY REMOVAL".
2. Place battery in a well ventilated area on a level surface.
3. Using distilled water, refill cells as required to cover cell plates of which can also be visualized through the plastic battery case.
4. With cell caps removed, connect battery charger to battery terminals. Red to positive (+) terminal and black to negative (-) terminal.
5. Slow charge battery at 1 amp for 10 hours.
6. If battery will not accept charge or is partially charged after 10 hours of charging at 1 amp, replace with new battery.

4.6.4. BATTERY STORAGE

If mower is to be stored out of season on its rear bumper, it is recommended the battery be removed, charged and stored.

1. Remove battery. Refer to Section "BATTERY REMOVAL".
2. Perform battery service.
3. Bring battery to full charge, if required.
4. Store battery in an area away from the RIDER on a wood surface. **DO NOT STORE BATTERY ON A CONCRETE SURFACE.**

4.6.5. NEW BATTERY PREPARATION

1. Remove battery from carton.
2. Place battery in a well ventilated area on a level non-concrete surface.
3. Remove battery cell caps. Fill cells as required with electrolyte (purchased separately) to proper level. Filling battery with electrolyte will bring the battery to 80% charged state.
4. With cell caps removed, connect battery charger to battery terminals; RED to positive (+) and BLACK to negative (-) terminal.



 **WARNING** 
DO NOT attempt to charge battery while installed on the Riding Mower. DO NOT use "BOOST" chargers on the battery. DO NOT OVERFILL!

5. Slow charge the battery at 1 amp for 2 hours to bring the battery to full charge.
6. After charging, check level of electrolyte and add as needed to bring level to 3/16" above cell plates.
7. Reinstall cell caps.
8. Remove the hair pin and swivel from the deck support to allow clearance for battery installation.
9. Slide battery partially into battery housing.
10. Connect positive (+) cable (red) first, from wiring harness to the positive terminal (+) on battery using bolt and nut provided in hardware bag. Connect negative (-) cable (black) last, to negative terminal (-) on battery using bolt and nut. Apply a small amount of grease over terminals to prevent corrosion.
11. Insert battery completely into battery housing.
12. Reinstall battery cover. See Figure 4.17.
13. Reinstall swivel and hair pin for deck support.

4.6.6. BATTERY TESTING

There are two types of battery tests: Unloaded and Loaded. The unloaded test is the procedure that will be discussed. It's the simplest and most commonly used. An unloaded test is made on a battery without discharging current. To perform unloaded testing, check charge condition using either a hydrometer or voltmeter.

1. Using a voltmeter, voltage readings appear instantly to show the state of charge. Remember to hook the positive lead to the battery's positive terminal, and the negative lead to the negative terminal.
2. A hydrometer measures the specific gravity of each cell. The specific gravity tells the degree of charge; generally, a specific gravity of about 1.265 to 1.280 indicates full charge. A reading of 1.230 to 1.260 indicates the battery should be charged. The chart on the next page shows the charge level as measured by syringe float hydrometer, digital voltmeter and five ball hydrometer.

 **WARNING** 
Shield the positive terminal with terminal cover located on battery harness. This prevents metal from touching the positive terminal, which could cause sparks.

(Battery Testing Chart on Next Page)



Section 4 - ADJUSTMENTS & REPAIR

4.6.6. BATTERY TESTING

Battery Condition Chart			
State of Charge	Syringe Hydrometer	Digital Voltmeter	Five Ball Hydrometer
100% Charged w/ Sulfate Stop	1.280	12.80v	Five Balls Floating
100% Charged	1.265	12.60v	Four Balls Floating
75% Charged	1.210	12.40v	Three Balls Floating
50% Charged	1.160	12.10v	Two Balls Floating
25% Charged	1.120	11.90v	One Ball Floating
0% Charged	Less than 1.100	Less than 11.80v	Zero Balls Floating

SNAPPER REAR ENGINE RIDER ACCESSORIES

PART NO.	DESCRIPTION OF KIT	MODELS USED ON
7060517.....	Wheel Weight (8" Wheels)	All Rear Engine Riders
7060601.....	Smooth Start Clutch	All Rear Engine Riders
7060697.....	Dump Cart	All Rear Engine Riders
7061400.....	Gauge Wheel.....	All 33" Deck Rear Engine Riders
7060794.....	Gauge Wheel.....	All 41" & 42" Deck Rear Engine Riders
7060941.....	Single Bag Catcher *	All 25" Deck Rear Engine Riders
7060942.....	Single Bag Catcher *	All 26" & 30" Deck Rear Engine Riders
7060943.....	Single Bag Catcher *	All 28" & 33" Deck Rear Engine Riders
7060944.....	Single Bag Catcher *	All 41" & 42" Deck Rear Engine Riders
7060945.....	Twin Bag Catcher *	All 41" & 42" Deck Rear Engine Riders
7060946.....	Twin Bag Catcher *	All 28" & 33" Deck Rear Engine Riders
7060947.....	Bag-N-Wagon *	All 28" & 33" Deck Rear Engine Riders
7060948.....	Thatcherizer.....	All Series 7 & Newer Riders
7060964.....	Wagon Cover.....	All 28" & 33" Deck Rear Engine Riders
7061190.....	Weight (Front).....	All Series 7 & Newer Riders
7060959.....	Dozer Blade (36" Blade).....	All Rear Engine Riders
7060357.....	Tire Chains (Tires-16 x 6.50-8)	All Rear Engine Riders
7060358.....	Tire Chains (Tires-16 x 4.80-8)	All Rear Engine Riders
7061823.....	Ninja Recycling (Cover).....	All 25" Deck Rear Engine Riders
7061049.....	Recycling (Cover).....	All 25" Deck Rear Engine Riders
7061253.....	Ninja Recycling (Cover).....	All 28" Deck Rear Engine Riders
7061254.....	Ninja Recycling (Cover).....	All 30" Deck Rear Engine Riders
7061255.....	Ninja Recycling (Cover).....	All 33" Deck Rear Engine Riders
7061987.....	Ninja Recycling (Cover).....	All 41" & 42" Deck Rear Engine Riders
7061910.....	Utility Trailer	
7061911.....	Aerator	
7061912.....	Dethatcher	
7061913.....	Lawn Sweeper	
7061914.....	Dethatcher Kit	
7061915.....	Lawn Roller	
7061916.....	Broadcast Spreader	

	<p>* WARNING</p> <p>Catcher bags used on SNAPPER products are made of woven fabric, and thus are subject to deterioration and wear during normal usage. Check condition of bags before each use. Immediately replace worn or damaged catcher bags with only bags recommended by SNAPPER.</p>	
---	---	---

TROUBLESHOOTING

PROBLEM	PROBABLE CAUSE	CORRECTIVE ACTION
Engine Will Not Start Using Recoil Starter	1. Fuel tank empty.	1. Fill fuel tank with fresh fuel to proper level.
	2. Engine needs choking.	2. Move choke control to "CHOKE" position.
	3. Spark plug wire disconnected.	3. Place spark plug wire onto spark plug.
	4. Faulty parking brake, blade or ignition switch.	4. Contact authorized SNAPPER dealer.
	5. Park brake not engaged.	5. Engage park brake.
	6. Ignition is in the OFF position.	6. Turn ignition switch to the RUN position.
Engine Will Not Start Using Electric Starter	1. Fuel tank empty.	1. Fill fuel tank with fresh fuel to proper level.
	2. Engine needs choking.	2. Move choke control to "CHOKE" position.
	3. Spark plug wire disconnected.	3. Place spark plug wire onto spark plug.
	4. Faulty parking brake, blade or ignition switch.	4. Contact authorized SNAPPER dealer.
	5. Park brake not engaged.	5. Engage park brake.
	6. Blown Fuse.	6. Replace with new 20 AMP fuse.
	7. Faulty interlock module.	7. Contact authorized SNAPPER dealer.
	8. Ignition is in the OFF position.	8. Turn ignition switch to the START position.
	9. Battery is weak or dead.	9. Charge or replace with new battery.
	10. Battery cables loose, broken disconnected or corroded.	10. Clean and connect battery cables. If broken, replace with new battery cables.
	11. Faulty electric starter or starter solenoid.	11. Contact authorized SNAPPER dealer.
	12. Starter cable loose, broken or disconnected.	12. Connect starter cable. If broken, replace with new starter cable.
	13. Electrical wiring harness disconnected or broken.	13. Connect or replace with new wiring harness.
Engine Stalls After Running	1. Operator not in seat.	1. Sit in operator's seat.
	2. Choke control in the "CHOKE" position.	2. Move choke control to "OFF" position.
	3. Fuel tank empty.	3. Fill fuel tank with fresh fuel to proper level.
	4. Engine air pre-cleaner and or air cleaner dirty.	4. Clean free of all debris.
	5. Spark plug defective or gap set improperly.	5. Service spark plug.
	6. Fuel filter restricted.	6. Replace fuel filter.
	7. Water, debris or stale fuel in fuel system.	7. Drain and clean fuel system.
Engine Loses Power	1. Excessive load on engine.	1. Lessen load.
	2. Engine air pre-cleaner or air cleaner dirty.	2. Clean or replace filters.
	3. Spark plug faulty.	3. Service spark plug.
	4. Water, debris or stale fuel in fuel system.	4. Drain and clean fuel system. Replace filter.
	5. Debris build up on engine cooling screen.	5. Clean all debris from engine cooling screen.
Engine Backfires When Turned To "STOP"	1. Throttle control set too "FAST".	1. Set throttle control to "SLOW" and allow engine to idle. Then, turn key to "OFF".
Excessive Vibration	1. Damaged, out of balance or bent mower blades.	1. Service mower blade(s).
	2. Loose blade components.	2. Service and tighten loose parts.
	3. Loose or missing air lift (if equipped).	3. Replace air lifts. Tighten to proper torque.
	4. Lumpy or frayed belt.	4. Replace belt.
	5. Bent Idler, stationary or spindle pulley.	5. Replace pulley.

(Trouble Shooting Continued on Next Page)

TROUBLESHOOTING

PROBLEM	PROBABLE CAUSE	CORRECTIVE ACTION
Rider Will Not Move Loss Of Traction	1. Drive disc worn or damaged.	1. Replace drive disc.
	2. Rubber drive disc is not tracking properly on drive disc.	2. Adjust rubber drive disc.
	3. Tapered axle bolt and nut missing.	3. Replace with SNAPPER tapered bolt & nut.
	4. Axle bearing seized.	4. Contact authorized SNAPPER dealer.
	5. Insufficient lubrication in chain case or transmission/differential.	5. Contact authorized SNAPPER dealer.
Blade(s) Not Cutting	1. Blade engagement lever in the "OFF" position.	1. Move lever to the "ON" position.
	2. Mower belt slipping.	2. Adjust or replace mower belt.
	3. Cutting blade is dull, worn or damaged.	3. Sharpen or replace cutting blade.
Cutting Grass Improperly	1. Uneven tire pressure.	1. Bring to proper pressure. 12 PSI front tire & 12 PSI rear tire.
	2. Cutting height too low or high.	2. Adjust cutting height.
	3. Engine speed too slow.	3. Move throttle control to "FAST" position.
	4. Forward speed too fast.	4. Move transmission shift lever to a slower speed.
	5. Terraced cut, side to side.	5. Adjust side to side level.
	6. Excessive deck pitch, front to rear.	6. Adjust front to rear pitch.
	7. Cutting blade(s) dull or damaged.	7. Sharpen cutting edges or replace blade(s).
	8. Mower belt slipping.	8. Adjust tension or replace mower belt.
Poor Grass Discharge	1. Engine speed too slow.	1. Move throttle control to "FAST" position.
	2. Forward speed too fast.	2. Move transmission shift lever to a slower speed.
	3. Grass is wet.	3. Mow when grass is dry.
	4. Excessively dull, worn or damaged blade(s).	4. Service mower blade.
	5. Build up of grass clippings and debris under deck.	5. Clean the underside of deck.
	6. Improper blade installed on deck.	6. Install proper SNAPPER blades.
Oil Leaking	1. Leaking chain case or differential plugs.	1. Verify plugs are not cracked & are in good shape. Check gaskets.
	2. Leaking engine block.	2. Contact authorized SNAPPER dealer.

MAINTENANCE SCHEDULE

SUBJECT	SERVICE TO BE PERFORMED	REFERENCE PAGES	EACH USE	5 HOURS	25 HOURS	50 HOURS	100 HOURS	EACH SEASON
Engine	Check Oil Level	Page 7	X					
Engine	Initial Oil Change	Page 14		X				
Engine	Periodic Oil Change	Page 16				X*		
Air Pre-Cleaner	Service Sponge Pre-Cleaner Element	Engine Manual			X**			
Air Cleaner	Replace Element	Engine Manual			X**			
Spark Plug	Replace Plugs	Engine Manual					X	
Fuel Filter	Replace Filter	Page 19					X	
Engine Cooling System	Clean Shrouds & Fins	Engine Manual					X**	
Battery	Check Electrolyte	Page 27			X			X
Battery	Charge Battery	Page 26, 27						X
Tires	Check Pressures	Page 7	X					
Drive Belts	Check For Wear And Tension	Pages 15, 25			X			X
Mower Blades	Check For Wear And Damage	Pages 24			X			
Mower Deck	Clean Debris Accumulation	Page 14, 16	X		X			X
Lubrication Points	Grease or Oil	Pages 16 - 18			X			X
Lubricate Chain Case & Transmission	Check Grease Level	Pages 17, 18					X	X
Blade Brake Stopping Time	Check blade stopping for proper operation	Pages 15, 20	X					X
Clutch/Brake System	Check Clutch/Brake for proper operation	Page 15, 23	X					X
Reverse Lockout Mechanism	Check function.	Page 7, 13, 16	X	X				

*Change oil every 25 hours when operating under heavy load or high temperatures.

**Clean more often under dusty conditions or when air debris is present

MAINTENANCE/REPLACEMENT PARTS

MAINTENANCE PARTS	
Engine Speed Control (Briggs Engine)	7022751
Engine Speed Control (Kohler Engine)	7074320
Engine Speed Control (Honda Engine)	7075089
Clutch/Brake Cable	7022449
Clutch/Brake Cable (33" Deck Models Only)	7074131
Brake Cable	7072648
28" Cutter Blade (Standard - Not Air Lift Compatible)	7035635
28" Cutter Blade (Standard - Air Lift Compatible)	7019515
28" Cutter Blade (Mulching)	7016980
28" Cutter Blade (Ninja - Quad Edge)	7026453
30" Cutter Blade (Standard - Not Air Lift Compatible)	N/A
30" Cutter Blade (Standard - Air Lift Compatible)	7018069
30" Cutter Blade (Ninja - Quad Edge)	7026565
33" Cutter Blade (Standard - Not Air Lift Compatible)	7034168
33" Cutter Blade (Standard - Air Lift Compatible)	7019523
33" Cutter Blade (Mulching)	7016982
33" Cutter Blade (Ninja - Quad Edge)	7024741
Air Lift Kit (28" & 33" Decks)	7060480
Air Lift Kit (30" Decks)	7060735
Engine to Cutting Deck Belt (28" & 30" Decks)	7022252
Engine to Cutting Deck Belt (33" Decks)	7043844
Rubber Drive Disc	7053103
Parts Manual for Rear Engine Rider Series 22 & 23	7006128

SNAPPER®

2 YEAR LIMITED WARRANTY

For two (2) years from purchase date for the original purchaser's residential, non-commercial use, **SNAPPER**, through any authorized **SNAPPER** dealer will replace, free of charge (except for taxes where applicable), any part or parts found upon examination by the factory at McDonough, Georgia, to be defective in material or workmanship or both.

For ninety (90) days from purchase date for the original purchaser's commercial, rental, or other non-residential use, **SNAPPER**, through any authorized **SNAPPER** dealer will replace, free of charge, any part or parts found upon examination by the factory at McDonough, Georgia, to be defective in material or workmanship or both.

All transportation costs incurred by the purchaser in submitting material to an authorized **SNAPPER** dealer for replacement under this warranty must be paid by the purchaser.

This warranty does not apply to certain transmissions, to engines and their components, and batteries, as these items are warranted separately. This warranty does not apply to parts that have been damaged by accident, alteration, abuse, improper lubrication, normal wear, or other cause beyond the control of **SNAPPER**. This warranty does not cover any machine or component part that has been altered or modified changing safety, performance, or durability.

Batteries have a one (1) year warranty period with free replacement if required for one (1) year from the original purchase date. **SNAPPER** will not be responsible for any installation cost incurred. The battery warranty only covers original equipment batteries and does not cover damage to the battery or machine caused by neglect or abuse, destruction by fire, explosion, freezing, overcharging, improper maintenance, or use of improper electrolyte.

There is no other express warranty.

DISCLAIMER OF WARRANTY

Implied warranties, including those of merchantability and fitness for a particular purpose, are limited to two (2) years from purchase date for the original purchaser's residential or other non-commercial use, and ninety (90) days from purchase for the original purchaser's commercial, rental or other non-residential use, and to the extent permitted by law, any and all implied warranties are excluded. This is the exclusive remedy. Liabilities for consequential damages, under any and all warranties are excluded.

Some states do not allow limitations on how long an implied warranty lasts, or do not allow the exclusion or limitation of incidental or consequential damages, so the above limitation or exclusion may not apply to you.

This warranty gives you specific legal rights, and you may also have other rights which vary from state to state.

WARNING: THE USE OF REPLACEMENT PARTS OTHER THAN GENUINE SNAPPER PARTS MAY IMPAIR THE SAFETY OF SNAPPER PRODUCTS AND WILL VOID ANY LIABILITY AND WARRANTY BY SNAPPER ASSOCIATED WITH THE USE OF SUCH PARTS.

IMPORTANT: Please fill out the attached **SNAPPER** Product Registration Card immediately and mail to:
Snapper's Product Registration Center, P.O. Box 1379, McDonough, Georgia 30253

PRIMARY MAINTENANCE

SNAPPER®

vs. DIRT!

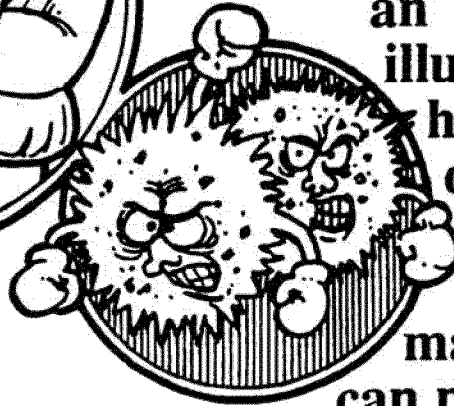

an illustration of how dirt can damage your engine & how reasonable maintenance can protect it!

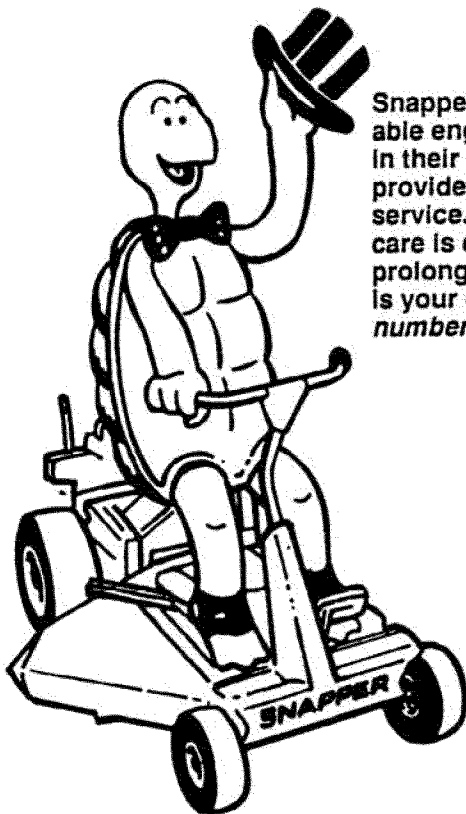

Snapper uses the best available engines and components in their products in order to provide long, satisfactory service. However, proper care is essential in prolonging engine life. Dirt is your engine's enemy number 1!

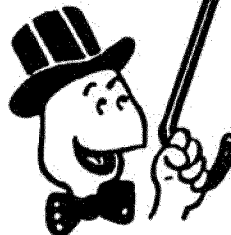

The engine on your Snapper product spends its entire life operating close to the ground at high speed creating a virtual storm of dust and dirt!

PRIMARY MAINTENANCE

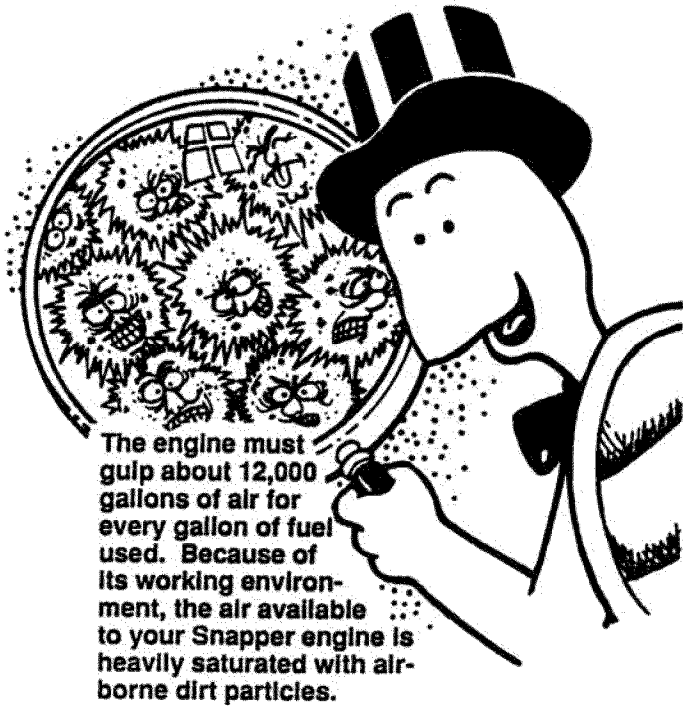

The engine must gulp about 12,000 gallons of air for every gallon of fuel used. Because of its working environment, the air available to your Snapper engine is heavily saturated with airborne dirt particles.

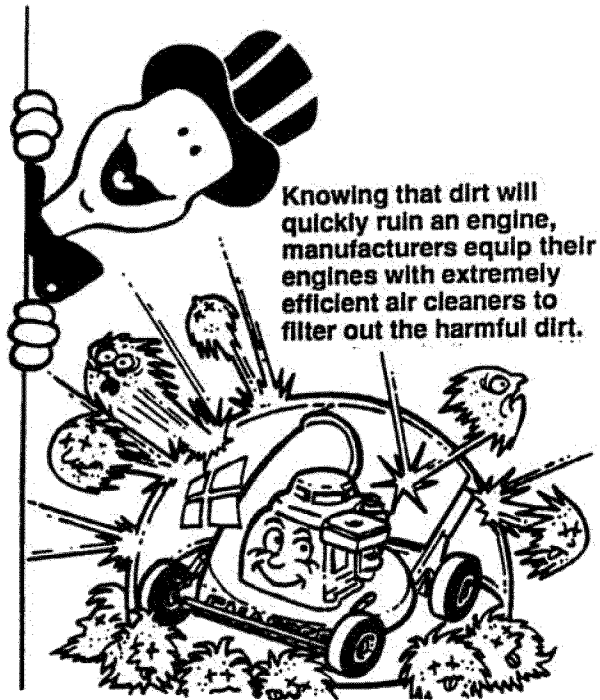

Knowing that dirt will quickly ruin an engine, manufacturers equip their engines with extremely efficient air cleaners to filter out the harmful dirt.

As the dirt particles are stopped, they build up and begin to clog the outside of the filter. This reduces the amount of air available to the engine and causes an over-rich fuel mixture which results in the following adverse effects:

An improperly serviced, dirt clogged air cleaner will:

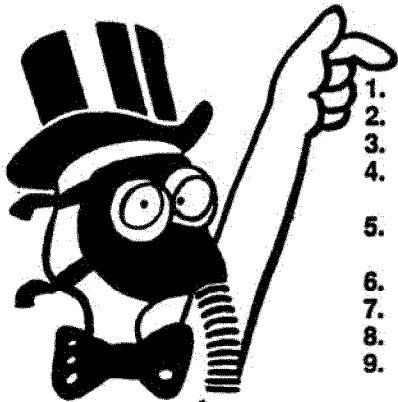

1. Increase fuel consumption
2. cause power loss
3. result in hard starting
4. create smoke from unburned fuel
5. produce carbon build-up internally
6. foul spark plug electrodes
7. score cylinder walls
8. burn valves
9. wear out the engine prematurely
10. COST YOU MONEY!

Damage caused by a poorly serviced air cleaner is not covered under the engine warranties. So, save yourself unnecessary expenses and undue aggravation by keeping the air cleaner properly serviced at the intervals specified in the engine owner's manual.

It doesn't take long to service an air cleaner. Follow the specific instructions in the engine owner's manual for the type filter used. Prevent dirt from falling into the carburetor intake when servicing your air cleaner. Make sure components are installed in correct sequence after servicing to prevent unfiltered air from entering the engine. Some servicing hints on several common types are:

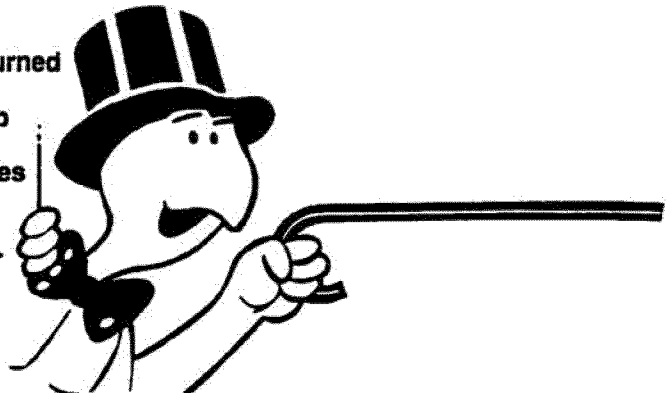

PRIMARY MAINTENANCE

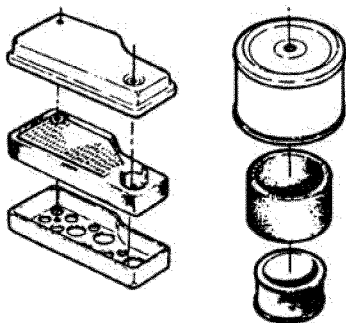

Generally, wash foam-type filters in a dishwashing detergent and water solution. Rinse and wring dry, then saturate with oil and squeeze out excess. *Failure to re-oil this type filter will ruin the engine.*

Clean paper elements by tapping lightly. Blowing with air will rupture paper elements.

Use a flashlight to detect clogged or torn paper elements - replace if damaged in any way.

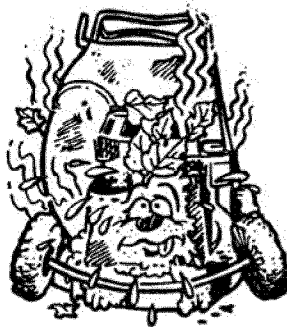

Air is also needed to keep your engine cool. Dirt, dust & debris build up to restrict and clog cooling air intake screens and fins. Clean screens and fins at frequent intervals. The engine blower housing and shrouds should be removed at least once each season or more often under dry, dusty conditions for a thorough cleaning of fins.

Failure to keep external surfaces clean not only presents fire hazards, but causes overheating and resulting engine damages such as:

1. distorted valve guides
2. sticking valves
3. scuffed, scored cylinder walls
4. overspeeding
5. loss of power
6. complete failure of engine.

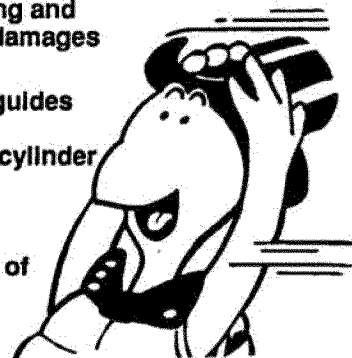

Dirt can also be introduced into an engine in dirty fuel from a contaminated container. Always use clean fresh fuel from a clean container to guard against dirt, sludge and water contamination.



Be aware that fuel breaks down in storage and forms gummy compounds which will block carburetor passages. Never use fuel more than 3 months old. Drain tank then run the engine out of fuel before storing during the off-season.



An engine must also have proper lubrication. All engines use some oil. On 4-cycle engines, **CHECK OIL LEVEL BEFORE EACH START-UP.** Wipe area clean around the oil check plug or dipstick opening to keep dirt from falling into the engine when checking the oil. Always check with the machine on a level surface. On engines with dipstick, keep the level up to, but not over, the **FULL** mark. When adding oil, allow time for all of the oil to flow down the fill tube to prevent a false full reading when the level could actually be low and result in engine damage.

PRIMARY MAINTENANCE

On 4-cycle engines with an oil level plug, don't be fooled into thinking the engine has sufficient lubricating oil if you can see "some" oil in the opening - the level should always be brought up to the point of overflowing at the top of the fill hole.

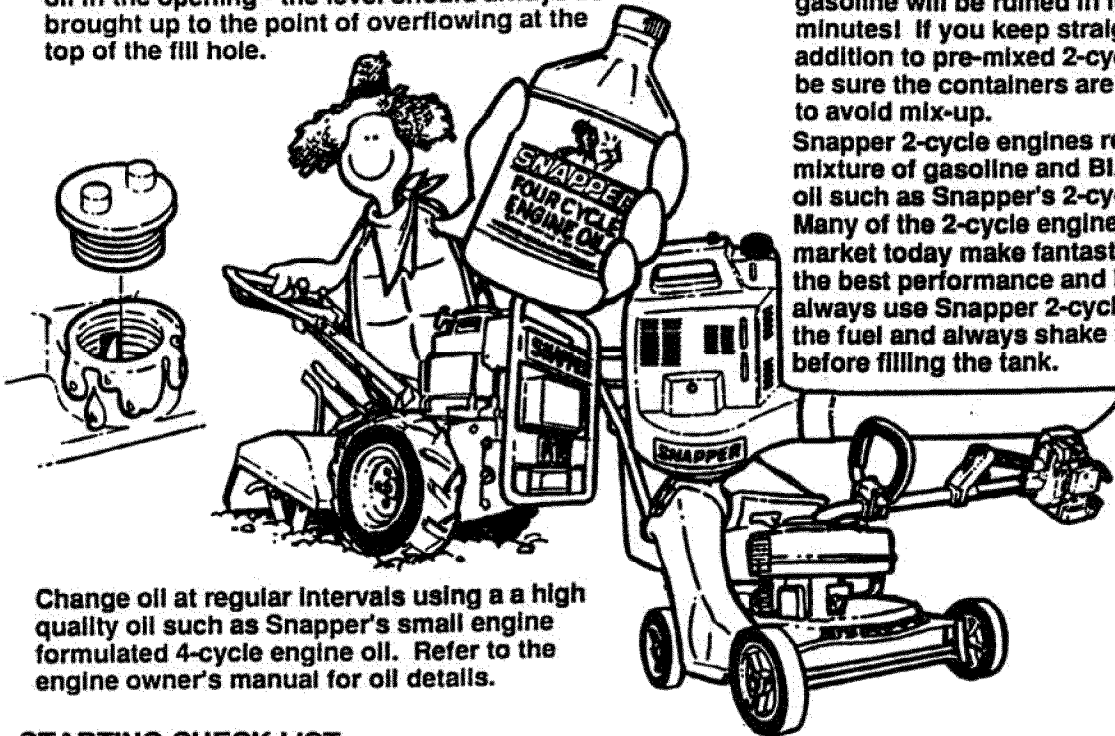

On 2-cycle engines, lubrication must be provided by an exact mixture of gasoline and 2-cycle air-cooled engine oil. A 2-cycle engine that is mistakenly run on straight gasoline will be ruined in less than 5 minutes! If you keep straight gasoline in addition to pre-mixed 2-cycle engine fuel, be sure the containers are clearly marked to avoid mix-up.

Snapper 2-cycle engines require a 32 to 1 mixture of gasoline and BIA certified TC-W oil such as Snapper's 2-cycle engine oil. Many of the 2-cycle engine oils on the market today make fantastic claims, but for the best performance and long engine life, always use Snapper 2-cycle oil. Pre-mix the fuel and always shake the container before filling the tank.

Change oil at regular intervals using a high quality oil such as Snapper's small engine formulated 4-cycle engine oil. Refer to the engine owner's manual for oil details.

STARTING CHECK LIST

- | | |
|------------------------------|--|
| 1. Engine Oil | <ul style="list-style-type: none"> • To full level (4-cycle) • Properly mixed with gas (2 cycle) |
| 2. Air Cleaner | <ul style="list-style-type: none"> • Clean and properly serviced • Full fresh clean gasoline |
| 3. Fuel Tank | <ul style="list-style-type: none"> • Fuel valve open • Cap vent open • Inline filter clean |
| 4. Choke | • Operating properly |
| 5. Primer (on some engines) | • Used properly |
| 6. Safety Interlock Switches | <ul style="list-style-type: none"> • In proper position • All wires properly connected |
| 7. Switch & Blade Control | <ul style="list-style-type: none"> • Switch On • Blade control properly positioned on walk mower |
| 8. Spark plug | <ul style="list-style-type: none"> • Wire connected • Good connection • Start position |
| 9. Throttle control | |
| 10. Blade | <ul style="list-style-type: none"> • Properly installed and torqued • Sharpened |
| 11. Muffler | <ul style="list-style-type: none"> • Good condition • Not clogged • Grass & leaves cleaned away |

Read and follow all safety instructions in safety booklets and manuals.

Keep in mind that dirt is your engine's *enemy* #1 both internally and externally! Internally, dirt will quickly ruin an engine and externally it will cause overheating and resulting internal damages. Damage caused by improper lubrication, poor air cleaner service or overheating due to dirt cannot be covered under warranty.

It only takes a few moments to service the engine (and equipment) on a routine basis but the rewards will be a quick starting, responsive engine that will provide long satisfactory service with minimum maintenance cost. The prestart checklist in the next column and instructions in your Snapper Operator's Manual are designated to help you keep your Snapper in top operating condition with minimum effort!

SNAPPER PRODUCT REGISTRATION FORM

**IMPORTANT: KEEP THIS INFORMATION FOR YOUR PERSONAL RECORDS
(Complete the following information on your Snapper purchase)**

Model Number _____

Serial Number _____

Date of Purchase _____

Retailer _____

Retailer's Phone Number _____

It is very important that you register your purchase with Snapper to ensure warranty coverage. Please mail your product registration card to:

Snapper at P.O. Box 777, McDonough, Georgia 30253.

Or you may register on line at www.snapper.com.

You can contact us at our web site or if you would like to speak with a Customer Service Representative. Call us at the Snapper Customer Relations Center. For faster service please have your Serial Number and Model Number available.

Call the Snapper Customer Relations Center at 1-800-935-2967.

Safety Instructions & Operator's Manual for
SNAPPER[®]
REAR ENGINE RIDING MOWER
SERIES 23

IMPORTANT

Snapper products are built using engines that meet or exceed all applicable emissions requirements on the date manufactured. The labels on those engines contain very important emissions information and critical safety warnings. Read, Understand, and Follow all warnings and instructions in this manual, the engine manual, and on the machine, engine and attachments. If you have any questions about your Snapper product, contact your local authorized Snapper dealer or contact Snapper Customer Service at Snapper, McDonough, GA. 30253. Phone: (1-800-935-2967).



WARNING

BATTERY POSTS, TERMINALS AND RELATED ACCESSORIES CONTAIN LEAD AND LEAD COMPOUNDS, CHEMICALS KNOWN TO THE STATE OF CALIFORNIA TO CAUSE CANCER AND BIRTH DEFECTS OR OTHER REPRODUCTIVE HARM. WASH HANDS AFTER HANDLING.



WARNING

ENGINE EXHAUST, SOME OF ITS CONSTITUENTS, AND CERTAIN VEHICLE COMPONENTS CONTAIN OR EMIT CHEMICALS KNOWN TO THE STATE OF CALIFORNIA TO CAUSE CANCER OR OTHER REPRODUCTIVE HARM.

SNAPPER[®] McDonough, GA., 30253 U.S.A.