

SAVE FOR FUTURE REFERENCE

4637037 / 0-4164588 (12-2-99)

## OWNER'S MANUAL

Model No. 415.154060



**Caution:**  
Read and follow all  
**Safety Statements,**  
**Assembly Instructions,**  
**and Use and Care**  
**Directions** *before*  
attempting to assemble  
and cook.

**Installer / assembler:** Leave  
these instructions with  
consumer.

**To Consumer:** Keep this  
manual for future reference.

 **Some parts may  
contain sharp edges,**  
**especially as noted in the  
manual! Wear protective  
gloves if necessary.**

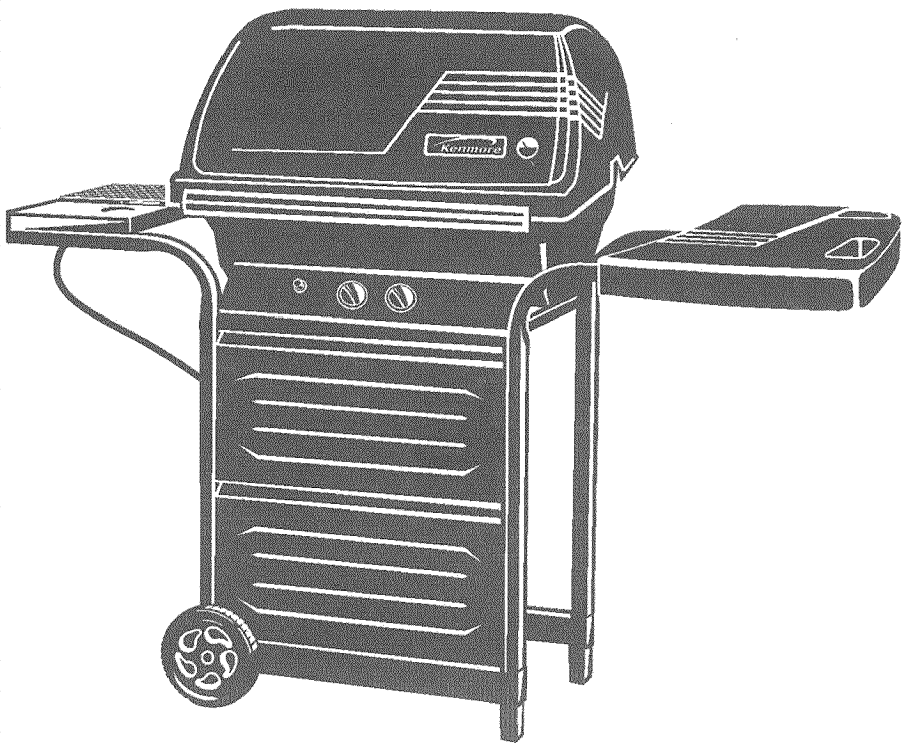

## LP GAS GRILL

- Assembly Instructions
- Parts List  
Parts Diagram

If you have questions or need assistance during assembly, please call 1-800-241-7548. You will be speaking to a representative of the grill manufacturer and not a Sears employee. If you would like to order replacement parts, please contact Sears at 1-800-366-PART as noted on the back of this manual.

**This Grill is for Outdoor Use Only**

**Sears, Roebuck and Co., Hoffman Estates, IL 60179 U.S.A**

Key	Qty	Description	Part #
1	2	Leg Assembly	4502044
2	2	Leg Extender	4156109
3	2	Rail	4503058
4	7	#10-24x1-1/2 Mach Screw	4080303
5	14	#10-24 Hex Nut (keys)	4080208
6	1	Tank Support Bracket	4502040
7	3	#10-24x3/8 Mach Screw	4080379
		STD511003	
8	4	End Cap	4080642
9	2	Wheel	4156956
10	2	5/16 Axle Bolt	4080155
11	4	3/4 Hitch Pin	4156515
12	8	#10x1/2 Self-Tap Screw	4080652
13	2	Fixed Panel	4503880
14	4	Push Fastener	4080675
15	1	Console	4525420
16	1	Valve/Hose/Regulator	4524315
17	1	Grill Bottom	4581968
18	1	Grease Clip	5156607
19	2	1/4-20x1-1/2 Mach Screw	4080324
		STD512515	
20	2	1/4-20 Hex Nut	4080656
21	1	Burner Assembly	4505008
22	1	Briquet Grate	4157101
23	1	Collector Box	4501543
24	1	Electrode	5156119
25	1	#6x3/8 Self-Tap Screw	4080264
26	1	Ignitor Wire	4153720
27	1	Drip VaporISER Bar	4156417
28	1	Side Shelf	4154283
29	5	#10x1-1/2 Screw	4080756
30	1	Grill Lid	4581045
31	2	1/4x1-1/8 Hinge Pin	4156513
32	1	Logo Plate	4156081
33	2	3/16 Pal Nut	4153096
34	1	Heat Indicator w/Bracket	4156800
35	1	Handle	4059000
36	2	#10-24x3-1/2 Mach Screw	4080307
37	2	Handle Spacer	5069502
38	2	Insulated Washer	4080418
39	1	SwingAway	4152124
40	1	Sideburner Body	4525153
41	1	Sideburner Frame	4501705
42	2	#6-32x3/8 Mach Screw	4080361
		STD510603	
43	1	Sideburner Valve Bracket	4501709
44	2	#10-24x3/8 Mach Screw	4080696
45	1	Sideburner Burner	4068076
46	1	Sideburner Ignitor Wire	5156109
47	1	Sideburner Grate	4156376
48	1	Sideburner Knob	4154248
49	1	Ignitor	5156113
50	2	Control Knob	4154203
51	1	Tank Wire	4154195
52	---	Briquets	4159300
53	1	Cooking Grate	4152739

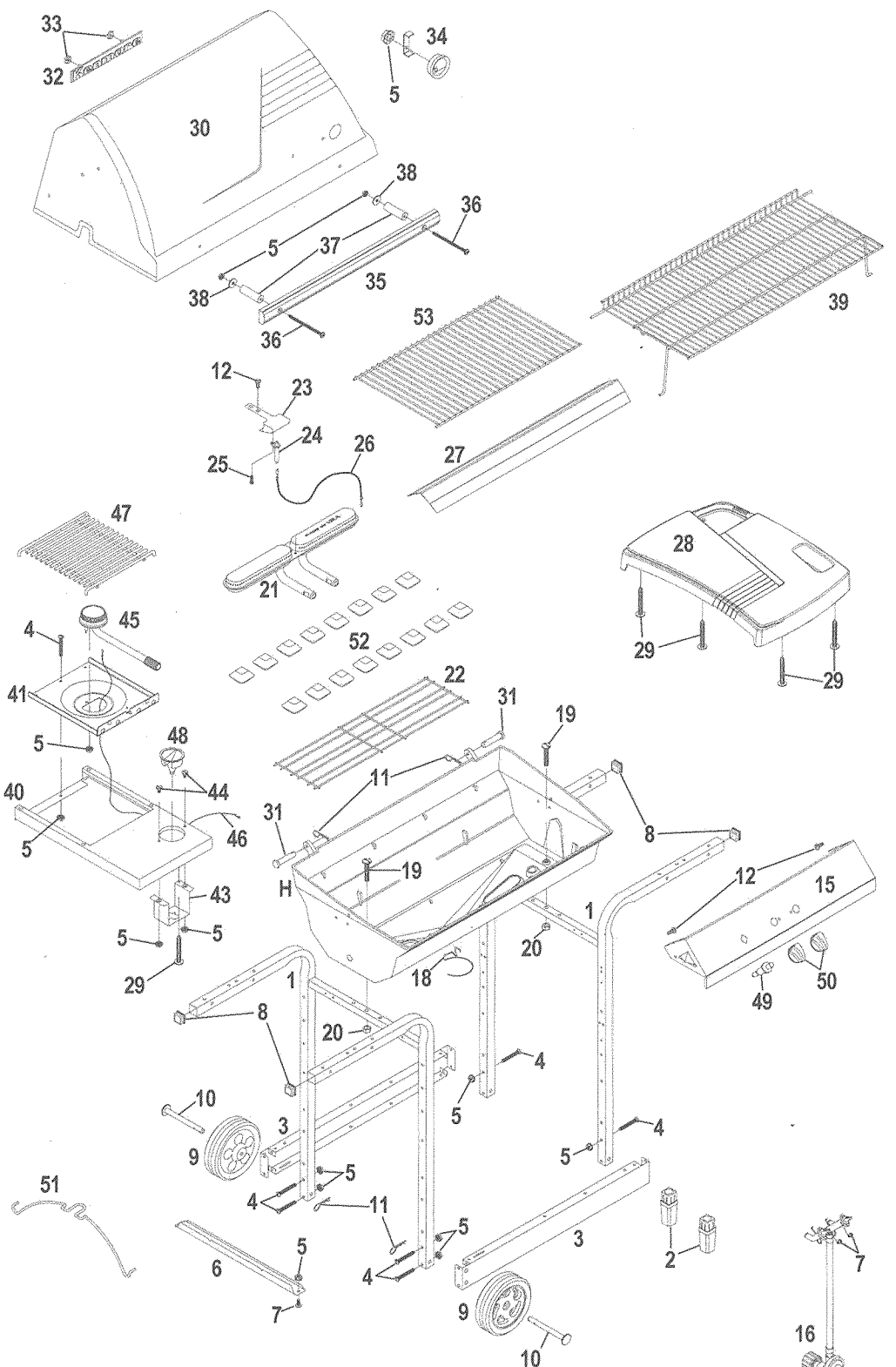

### Before Beginning Assembly

- Necessary tools for assembly of your grill include: screwdrivers (flathead and Phillips®), hammer, pliers and adjustable wrench. A 3/8" and 7/16" nut driver would be ideal.

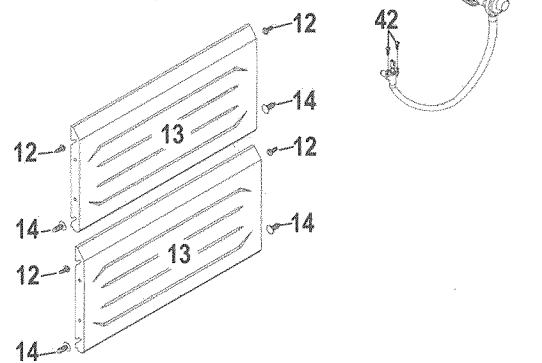
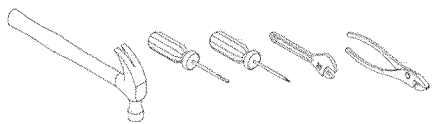

**1**

**NOTE:** Rail with label has the serial and model number for your grill. Write this information on Page 2 of your Use and Care in the "Warranty Information" box.

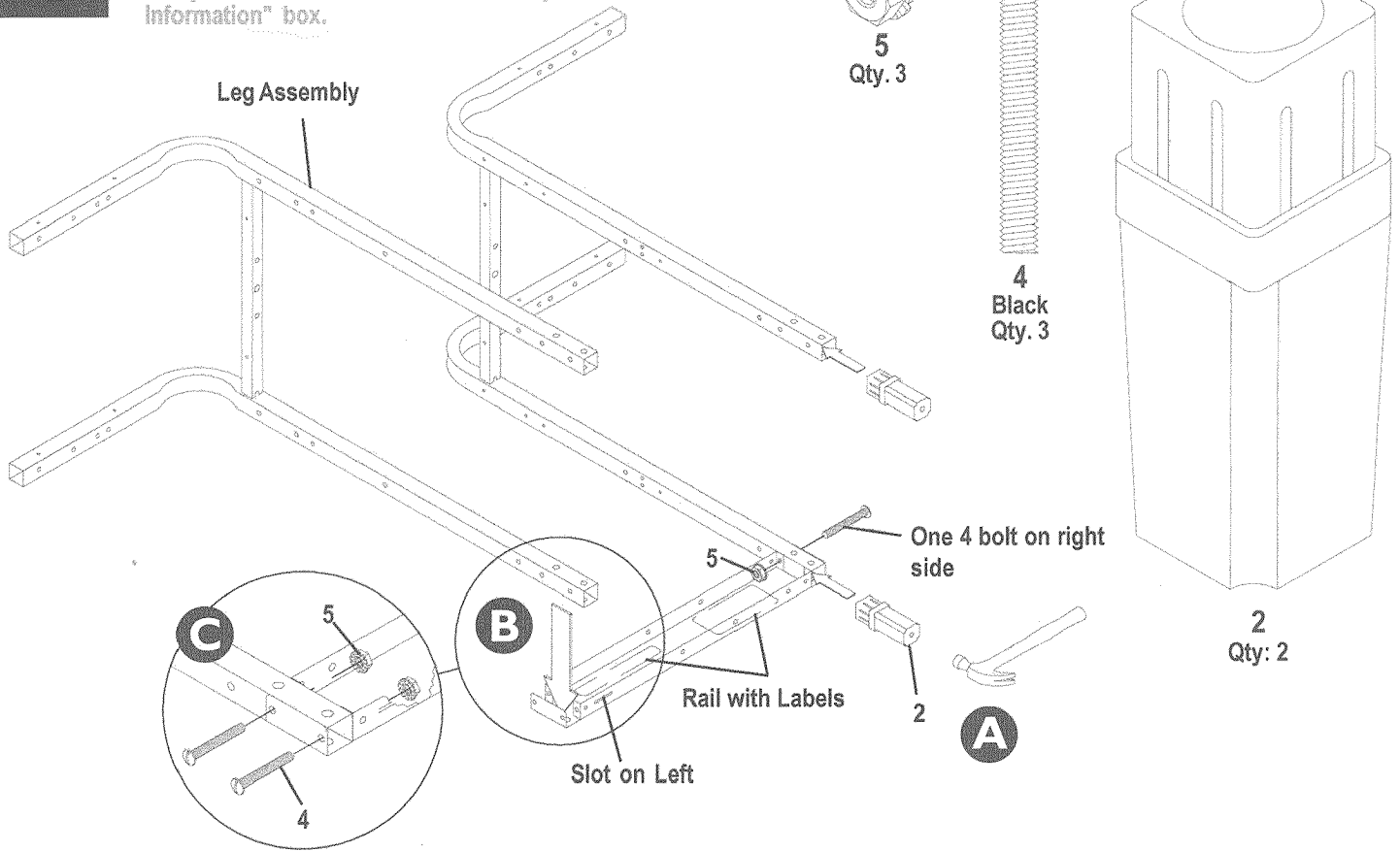

**2**

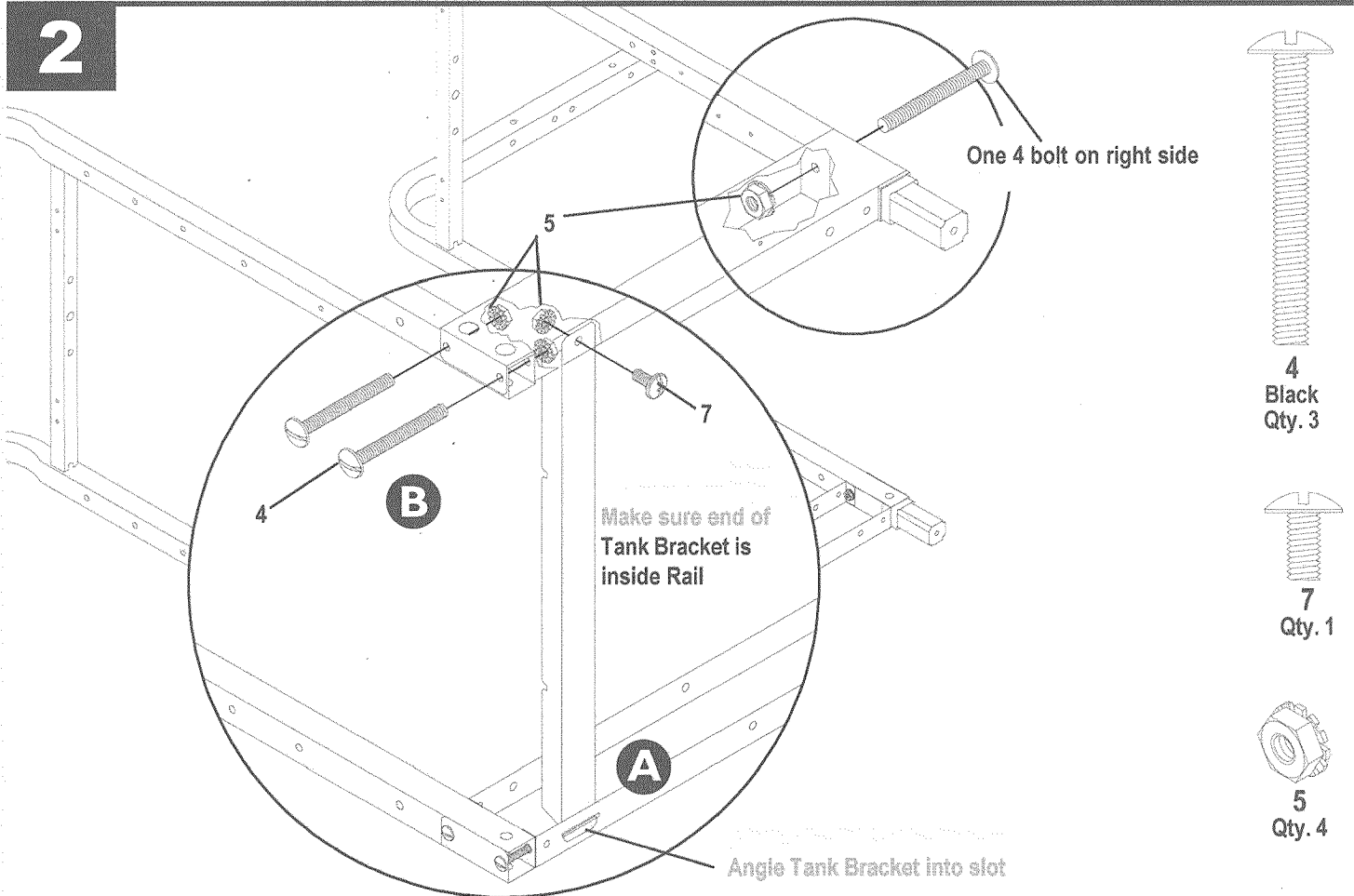

**3**

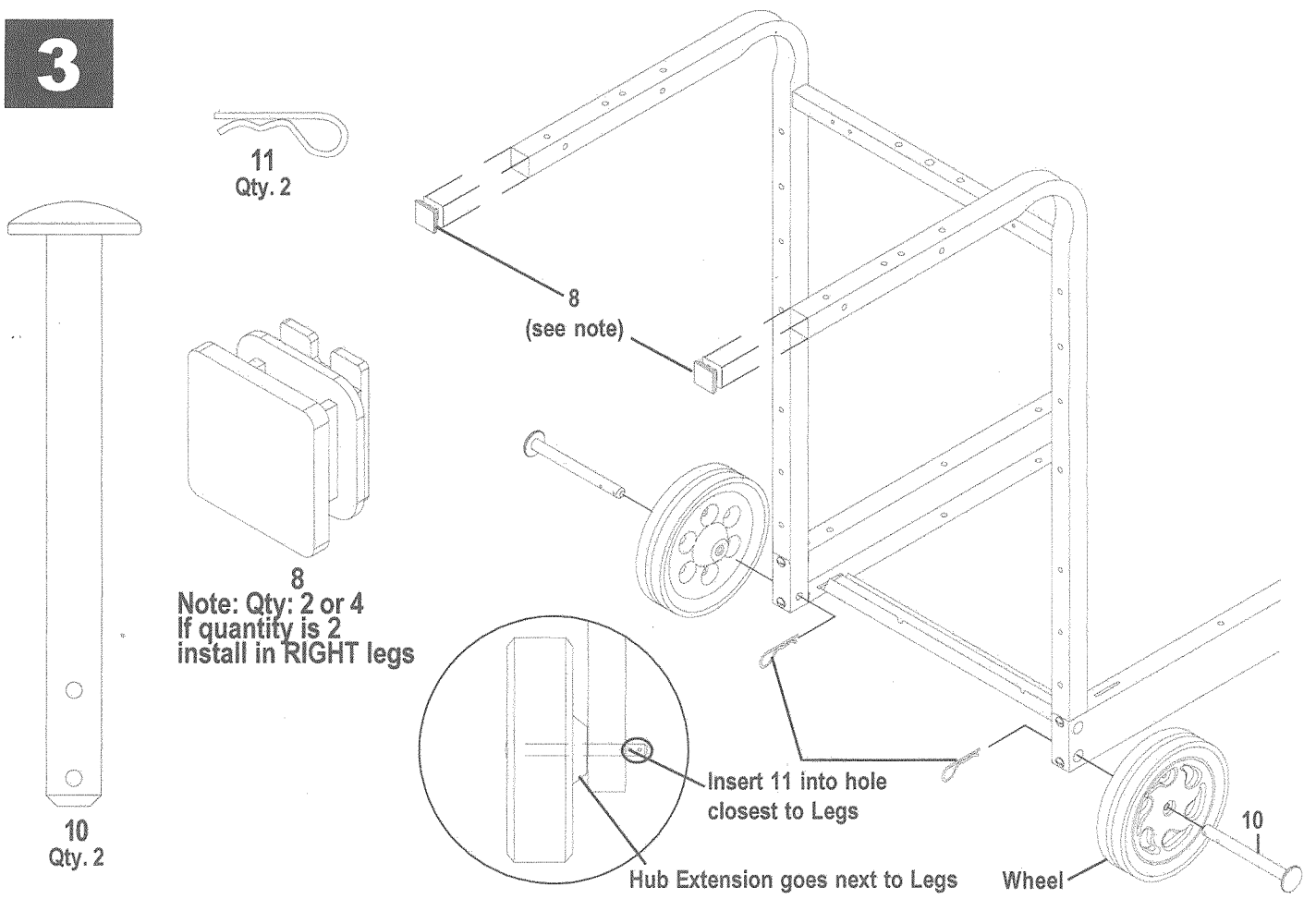

**4**

▲ Fully tighten after Console is attached

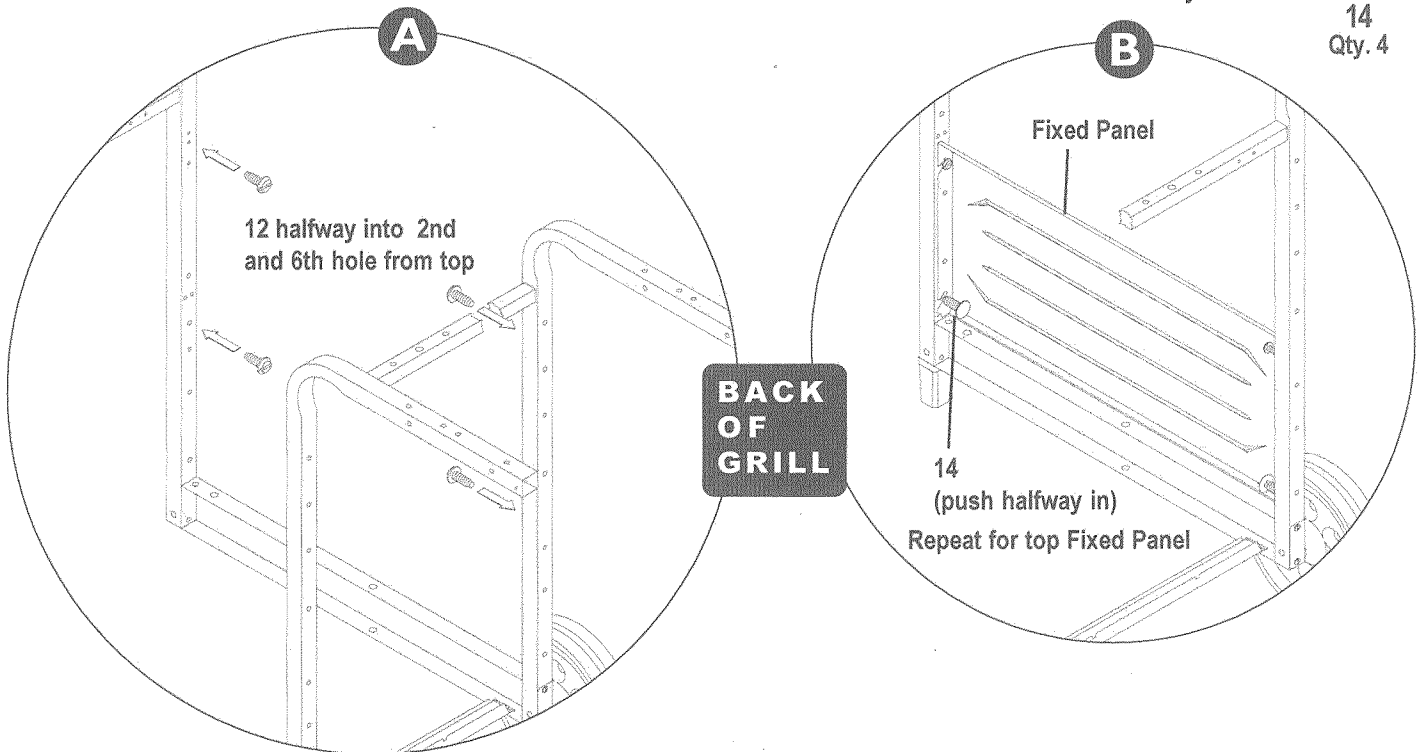
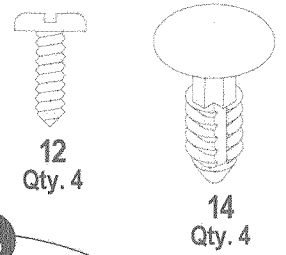

5



▲ Fully tighten screws on the fixed panels.

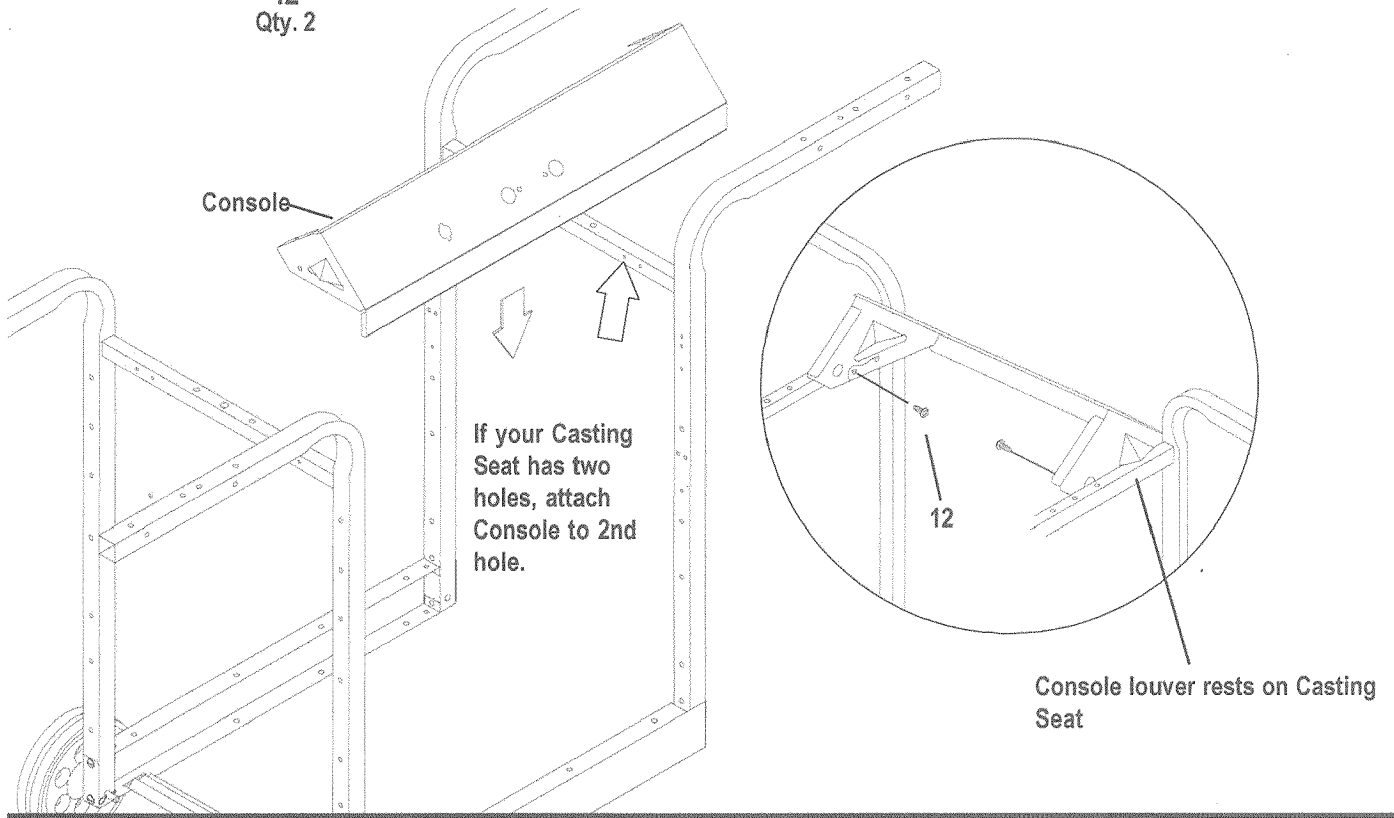

6

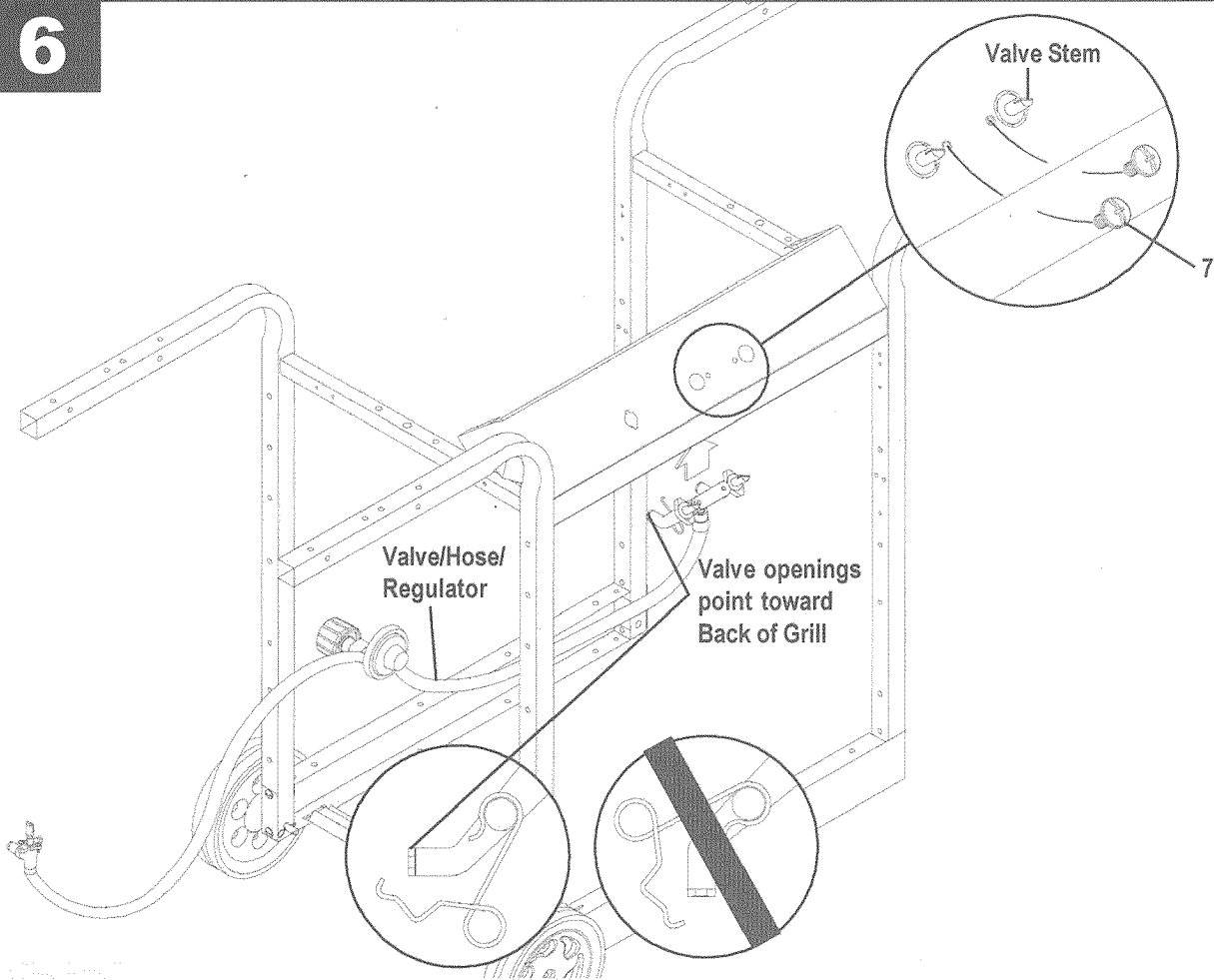
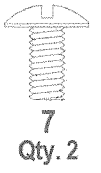

7

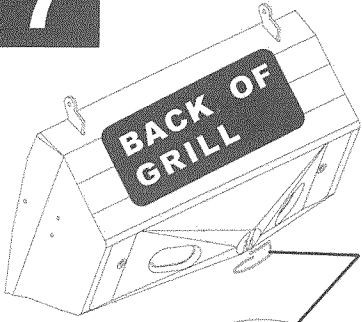

A

▲ Use an empty soup can to hang from the Grease Clip.

### CAUTION

- Failure to install can in clip will cause hot grease to drip from bottom of grill with risk of fire or property damage.

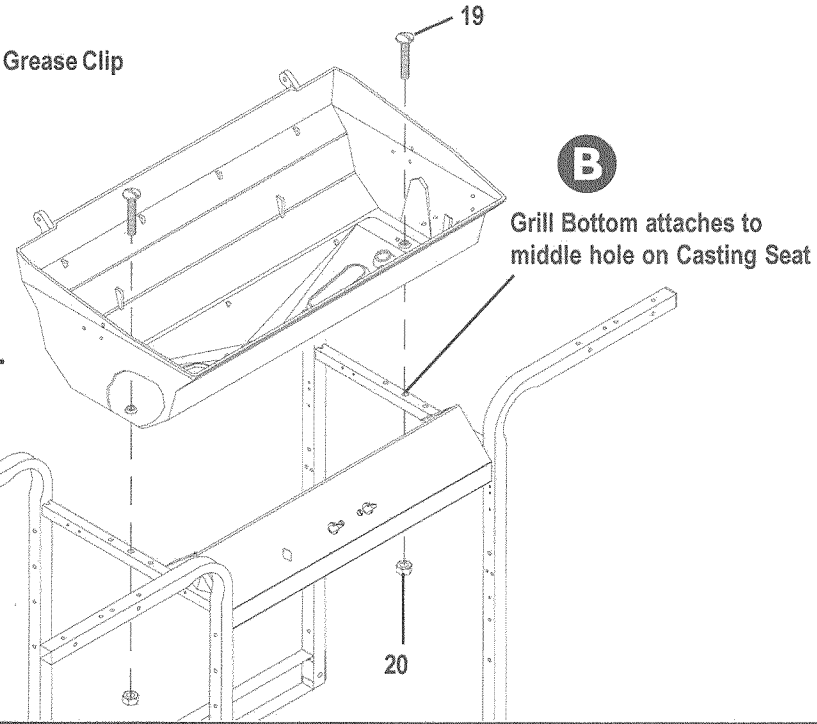

B

Grill Bottom attaches to middle hole on Casting Seat

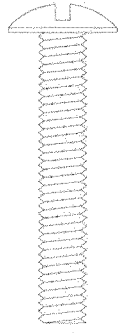

19  
Qty. 2



20  
Qty. 2

8

▲ **VERY IMPORTANT:**  
 Burner tubes must pass through holes in grill bottom and engage valve attached to console.

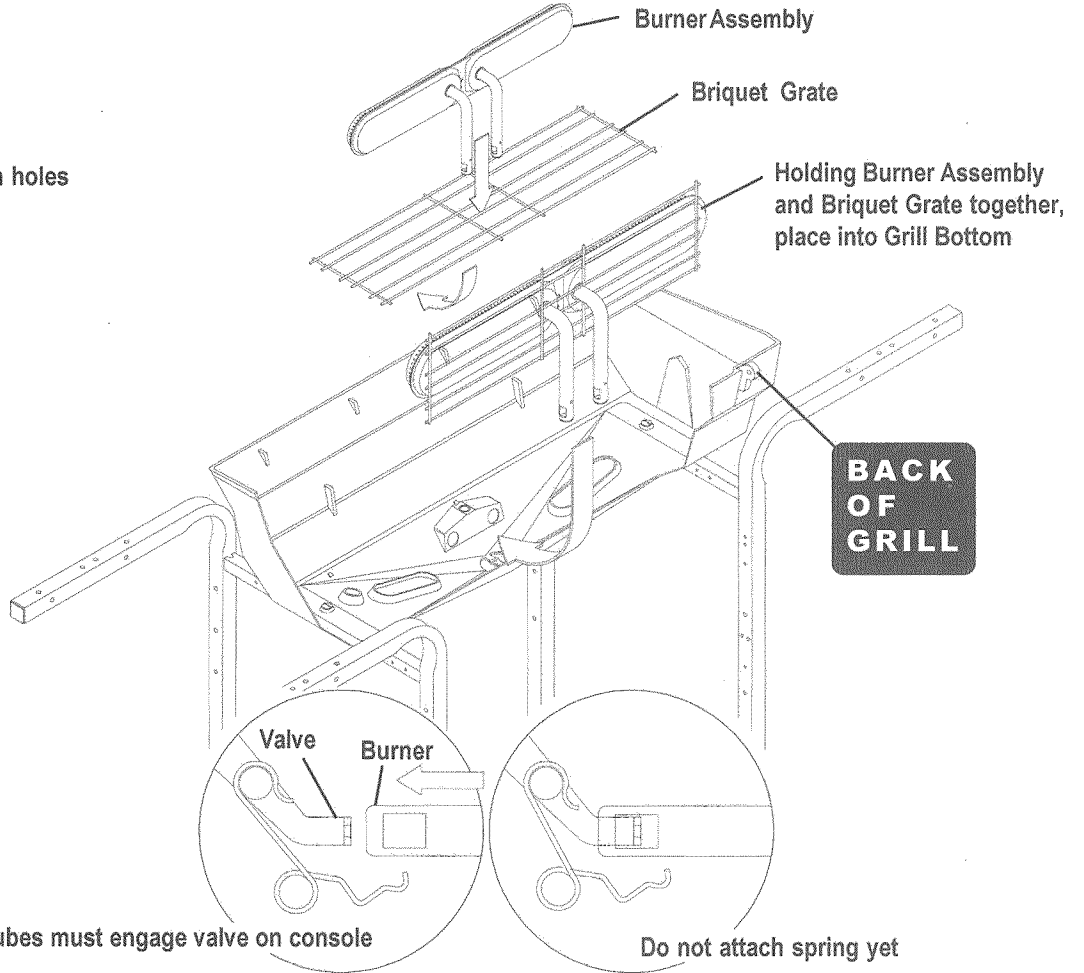

BACK OF GRILL

Burner Tubes must engage valve on console

Do not attach spring yet

# 9

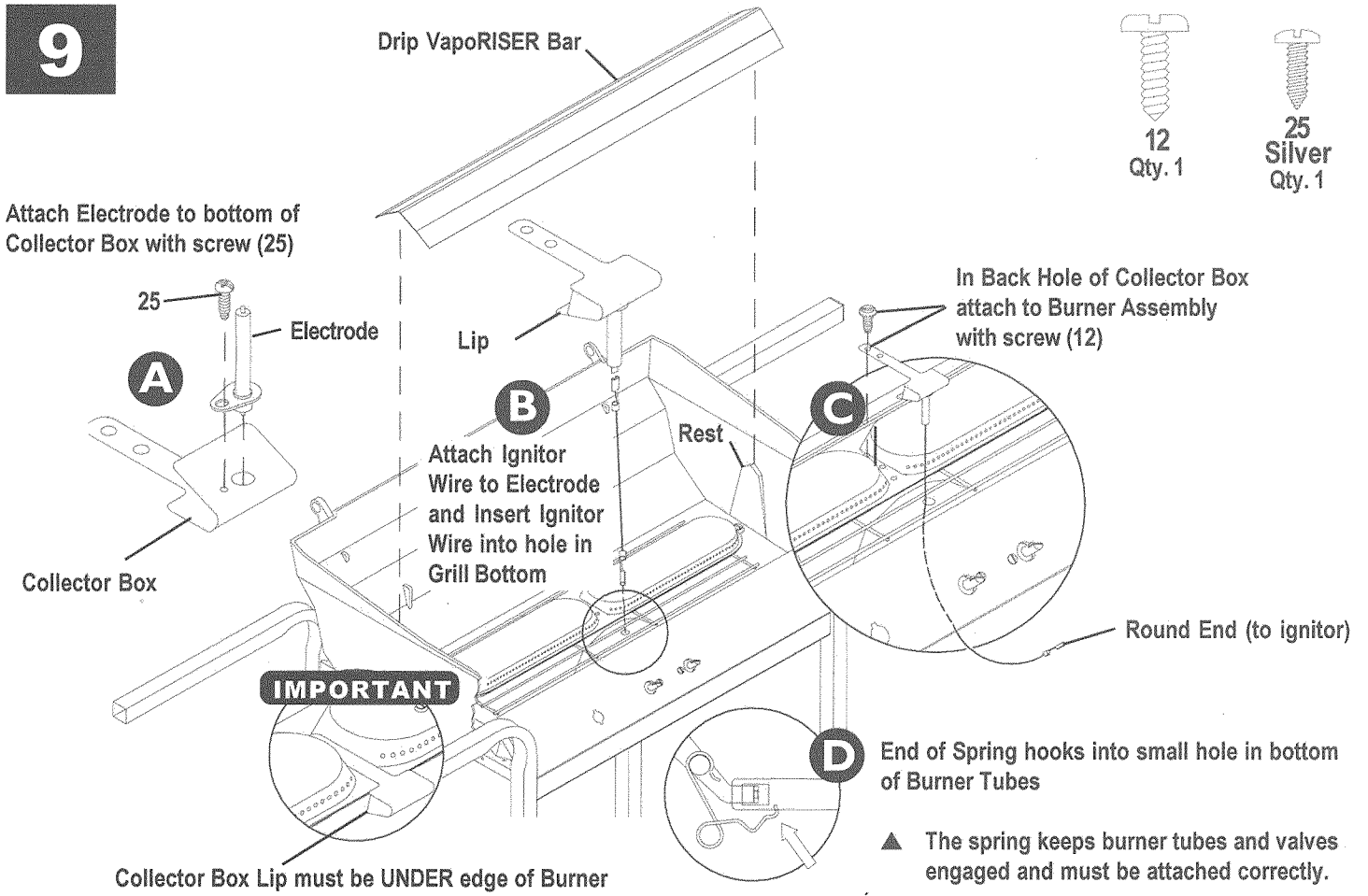

# 10

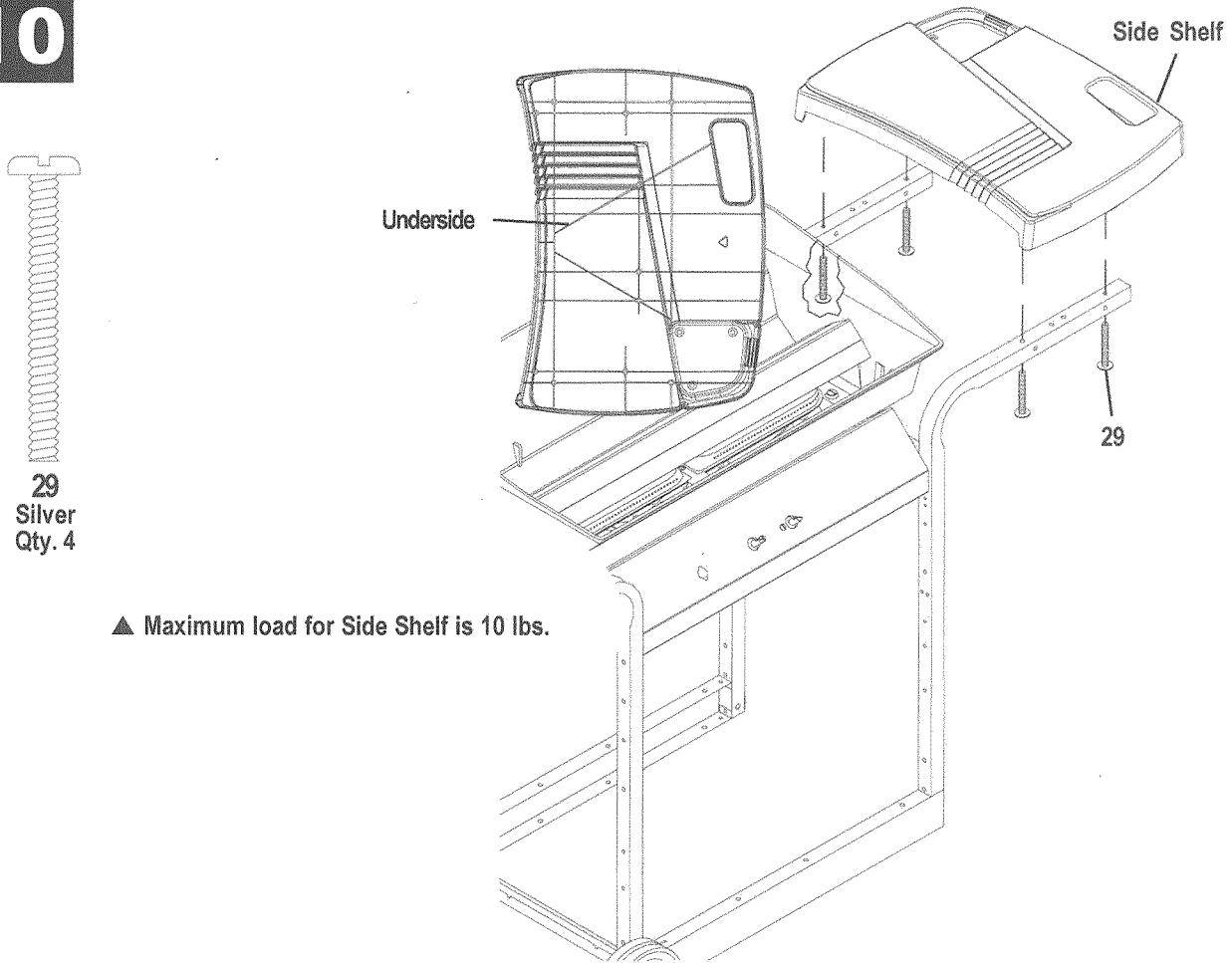

# 11

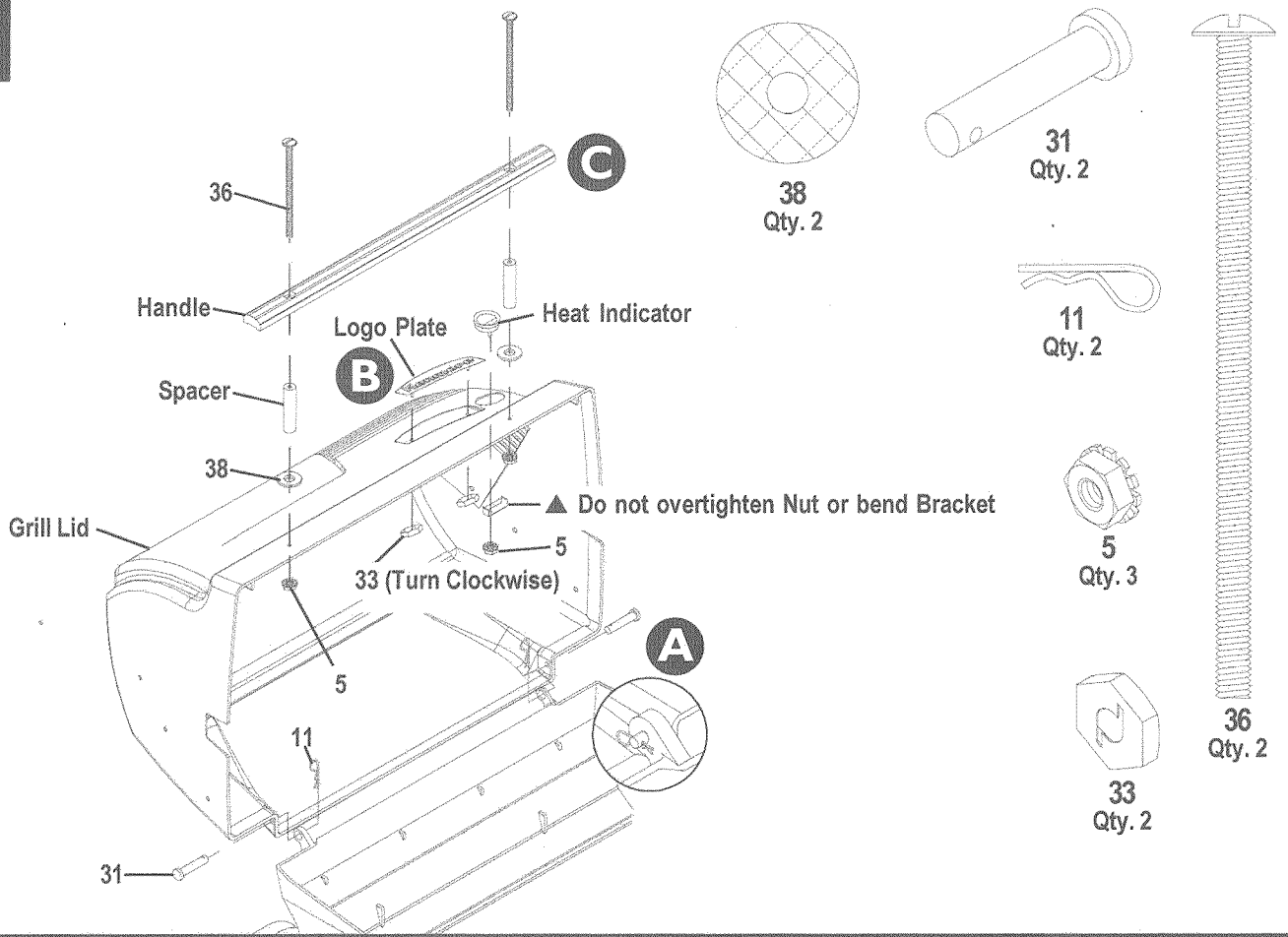

# 12

- ▲ SwingAway will keep food warm, while keeping it away from flames. Do not use SwingAway for cooking meats or heavy food items.
- ▲ Pivot and leg wires must run underneath SwingAway surface.

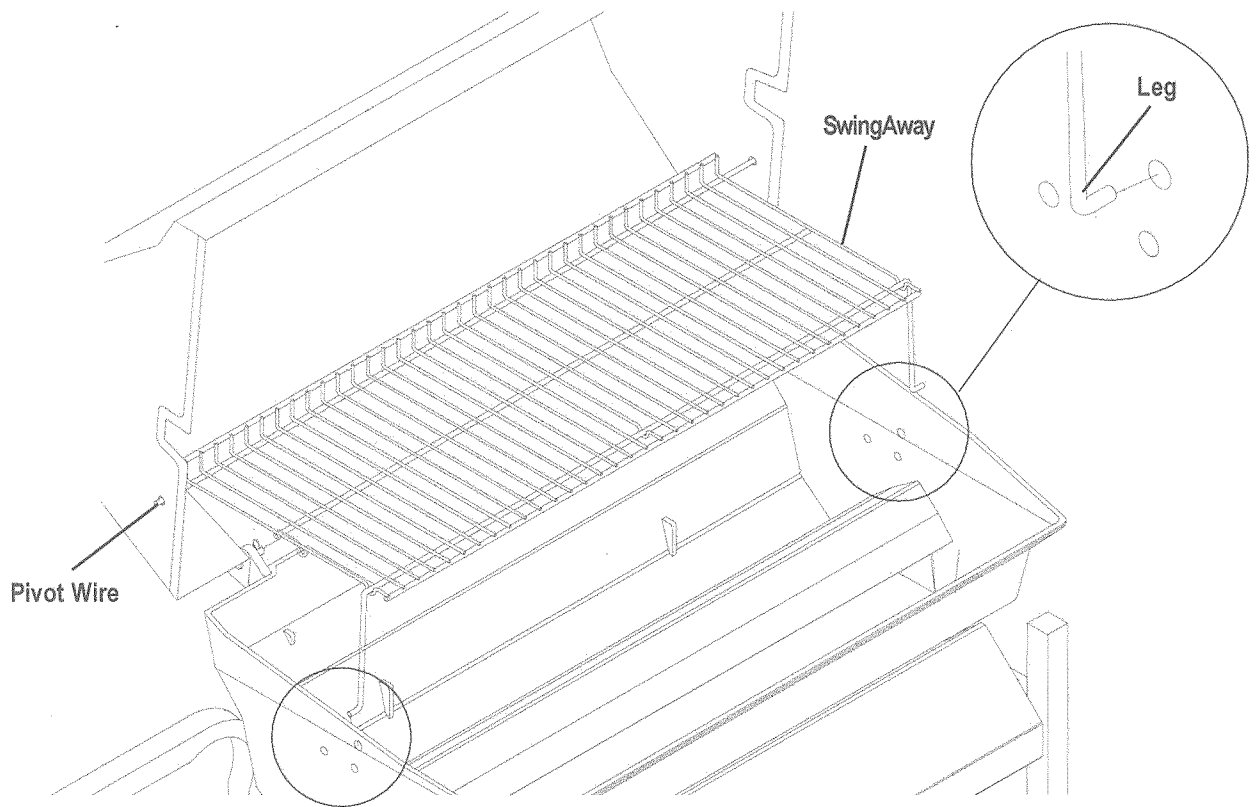



# 13

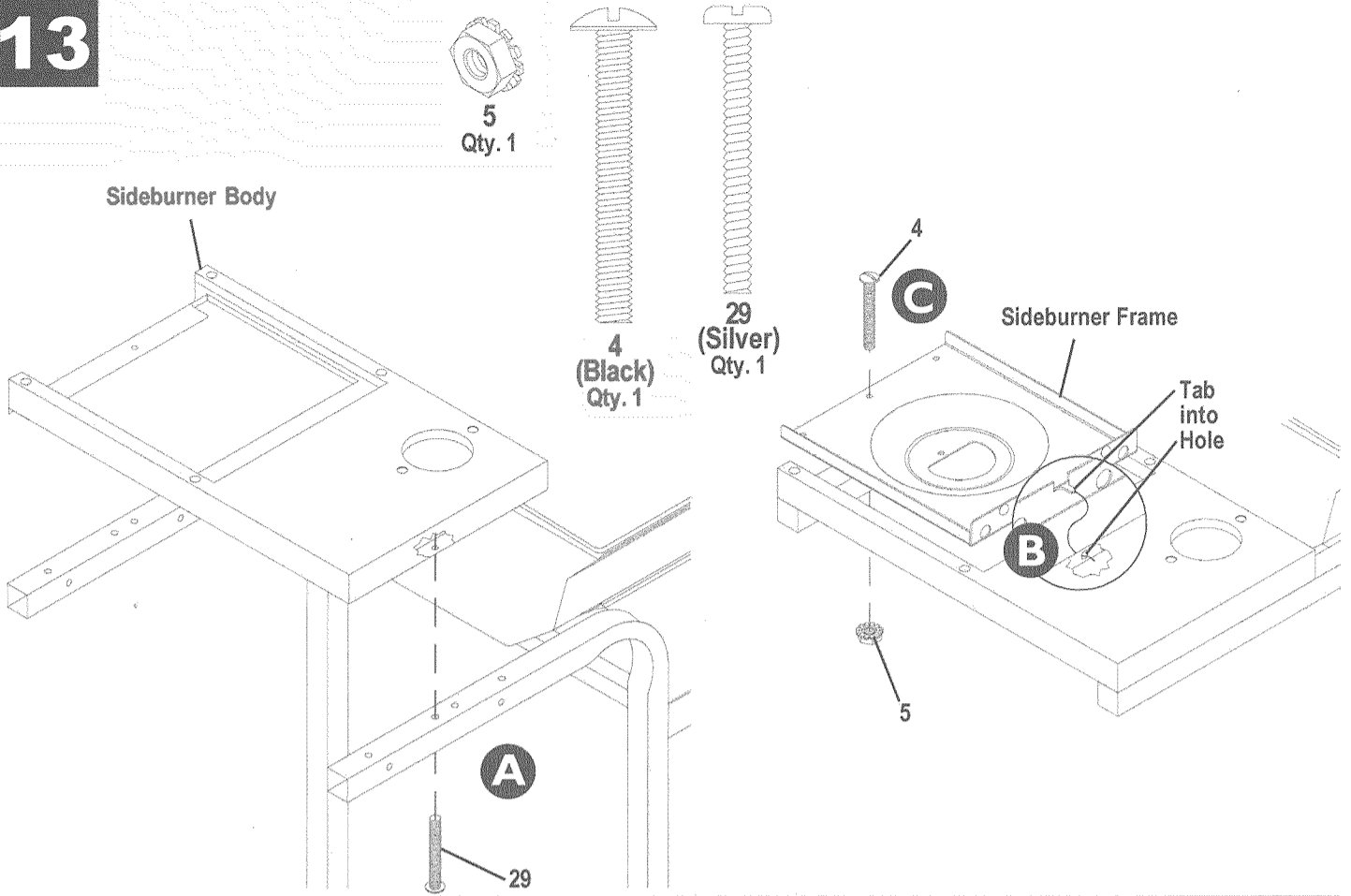

# 14

Thread 42 halfway into sideburner valve, place in right slot of valve bracket



5 Qty. 3

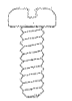

42 Qty. 2



44 Qty. 2

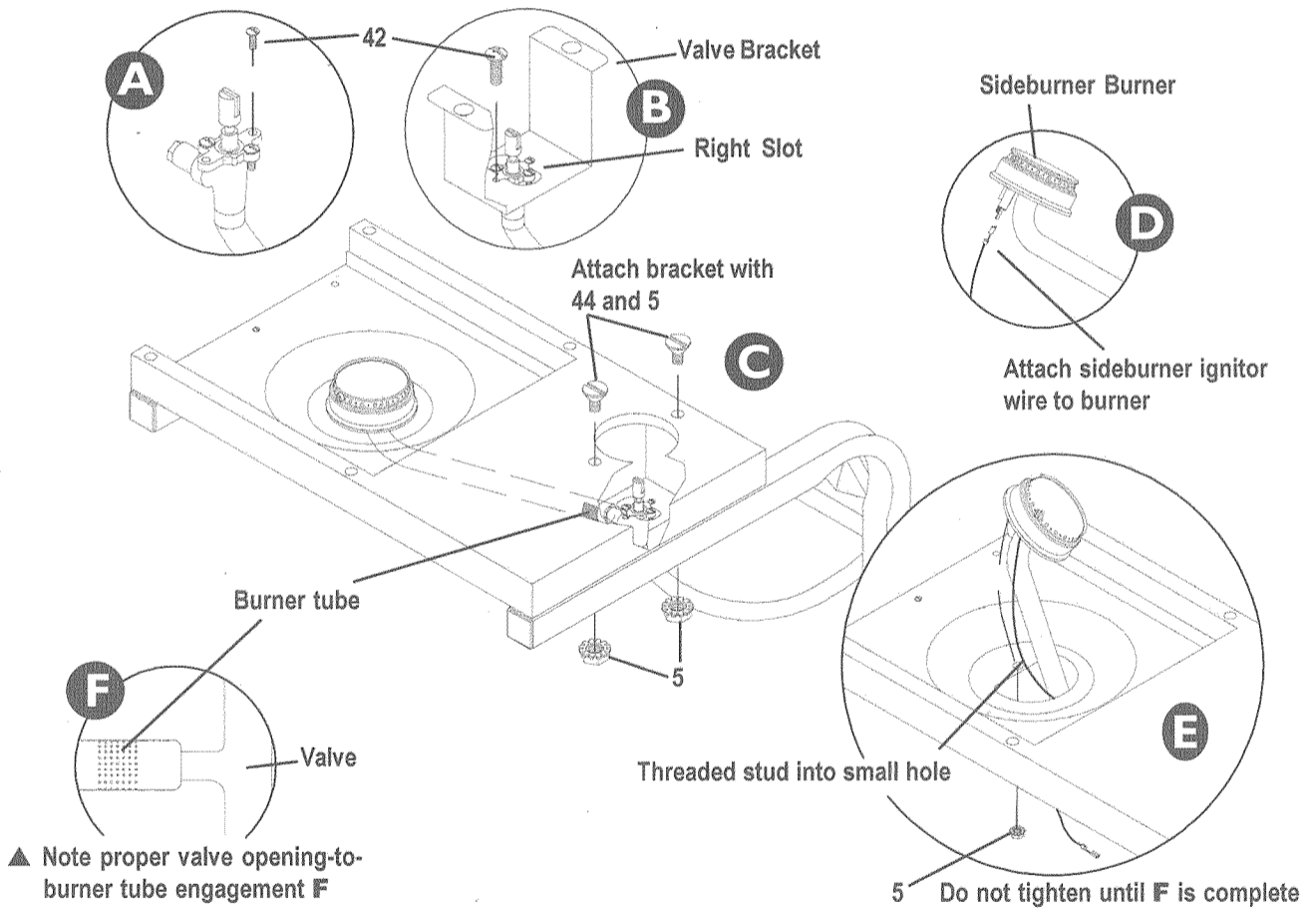

# 15

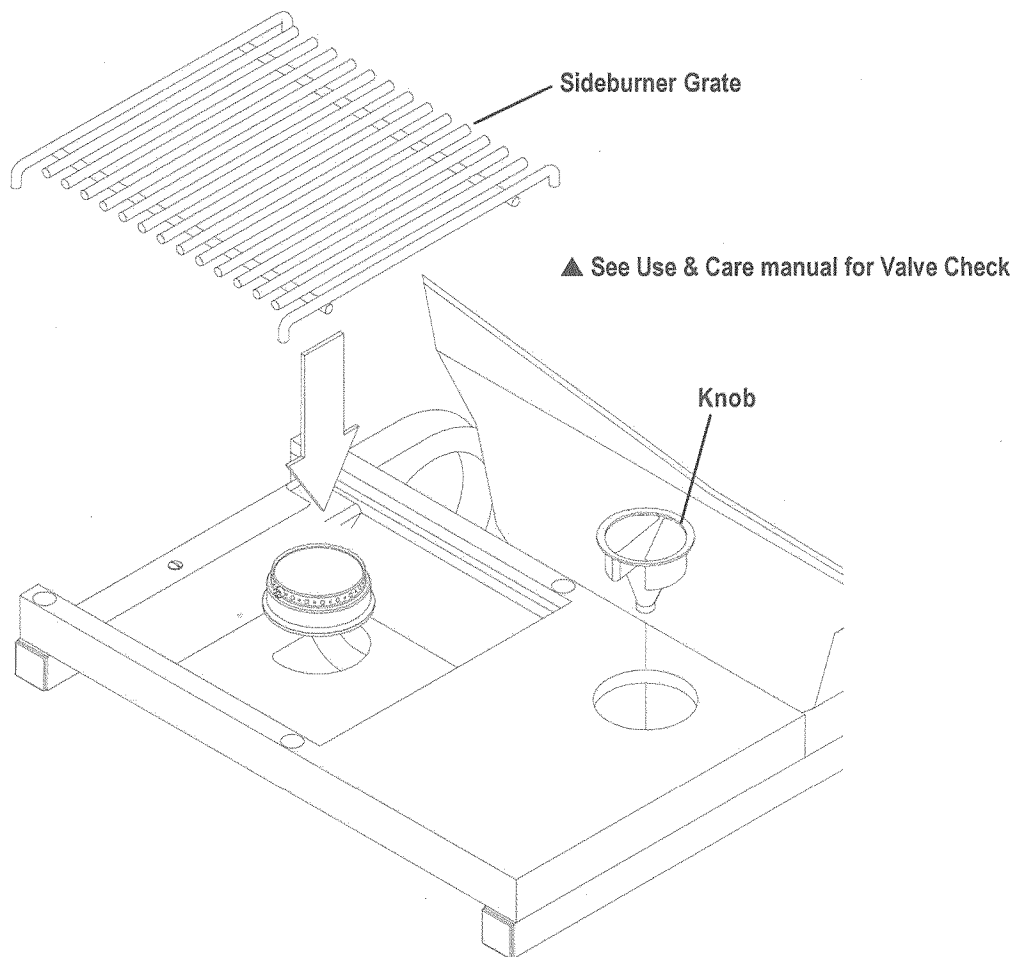

# 16

- ▲ When installing Ignitor do not push on button. This may cause a minor shock.
- ▲ Sideburner electrode wire must be connected to Ignitor for grill and Sideburner to ignite.
- ▲ Ignitor Wire(s) must not come into contact with grill bottom.
- ▲ See Use and Care for Valve Check.

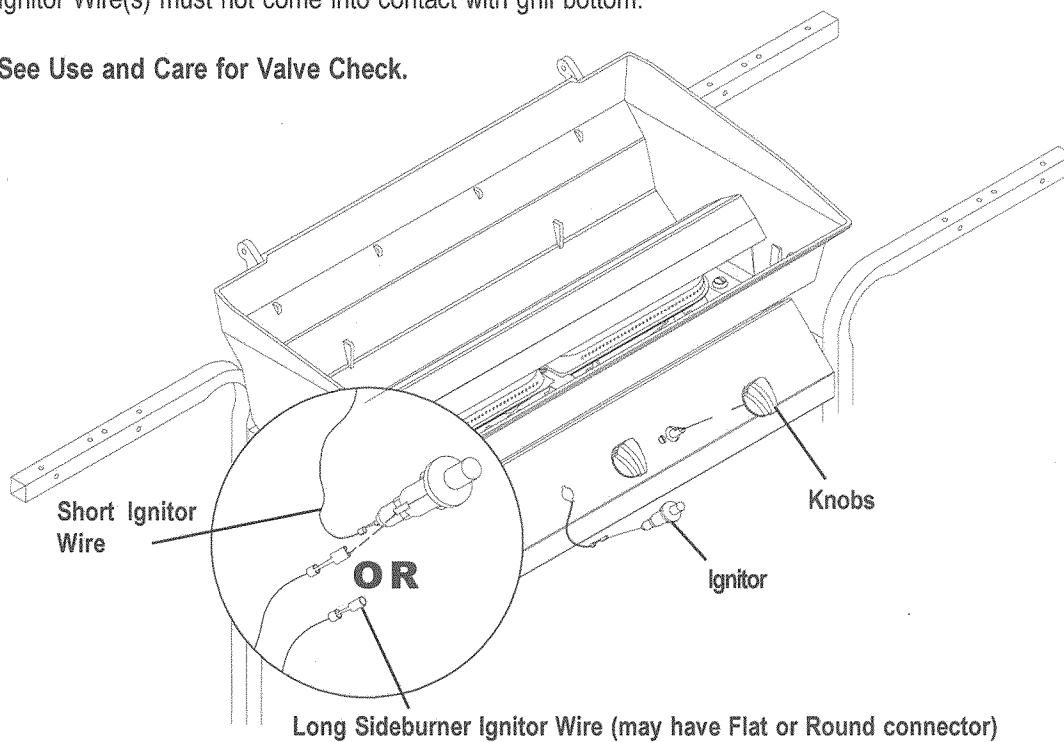

# 17

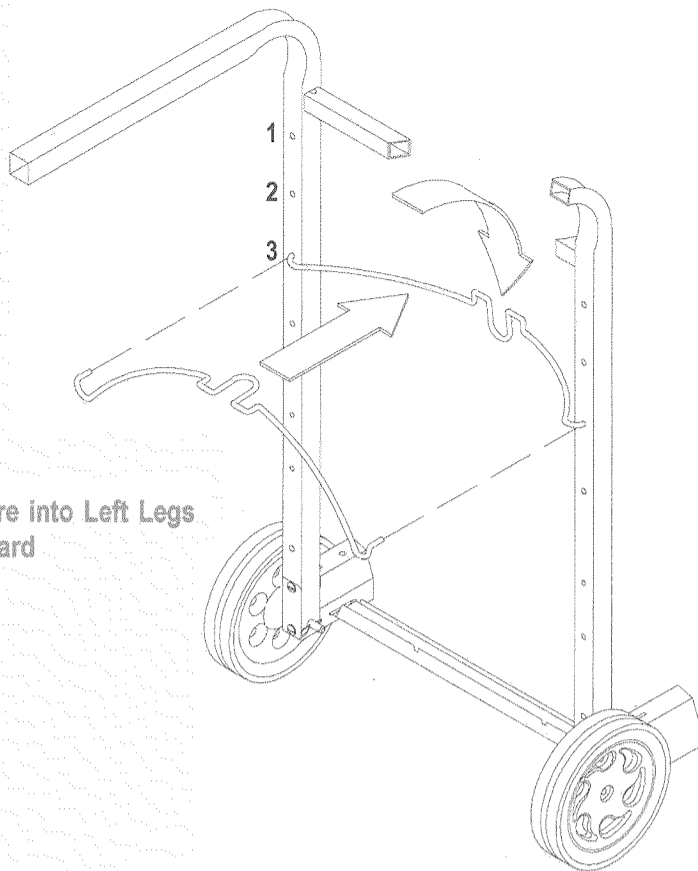

Insert Tank Wire into Left Legs and rotate inward

# 18

▲ LP tank is sold separately. Fill before attaching to grill.

▲ Curved portion of tank wire should be to inside of tank collar.

▲ For filling of tank and connection of tank to regulator, see the Use and Care Manual.

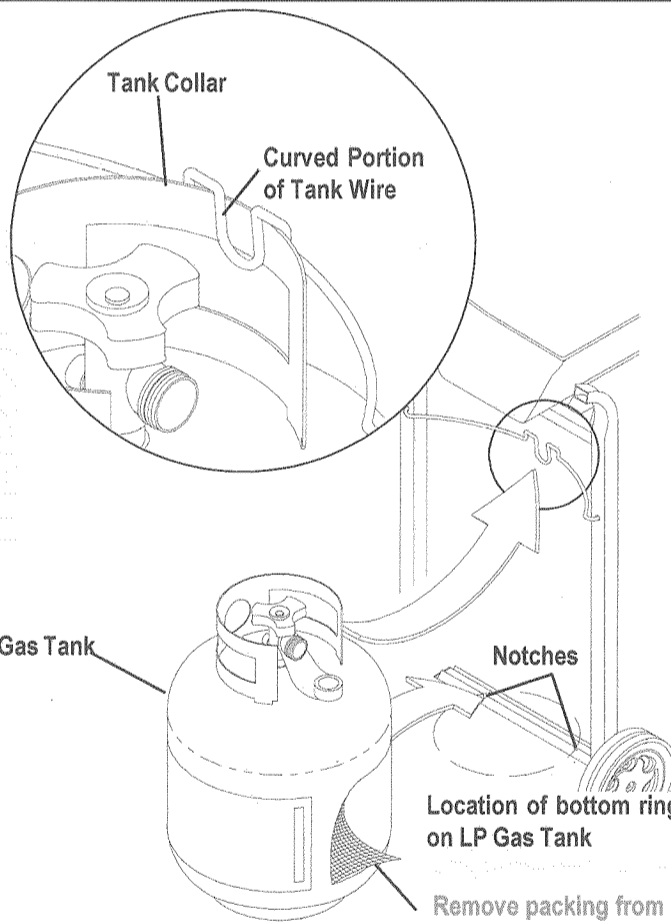

## CAUTION

- Tank collar opening must face to front of cart once tank is attached.
- Failure to install tank correctly may allow gas hose to be damaged in operation.

See Use and Care Manual for important safety instructions before using.

# 19

Perform the "Burner Flame Check" in the Use and Care section.

▲ Let grill cool before placing briquets.

Place 16 briquets. Do not layer or stack just enough to cover fire grate surface.

▲ Do not let briquets cover burner port holes

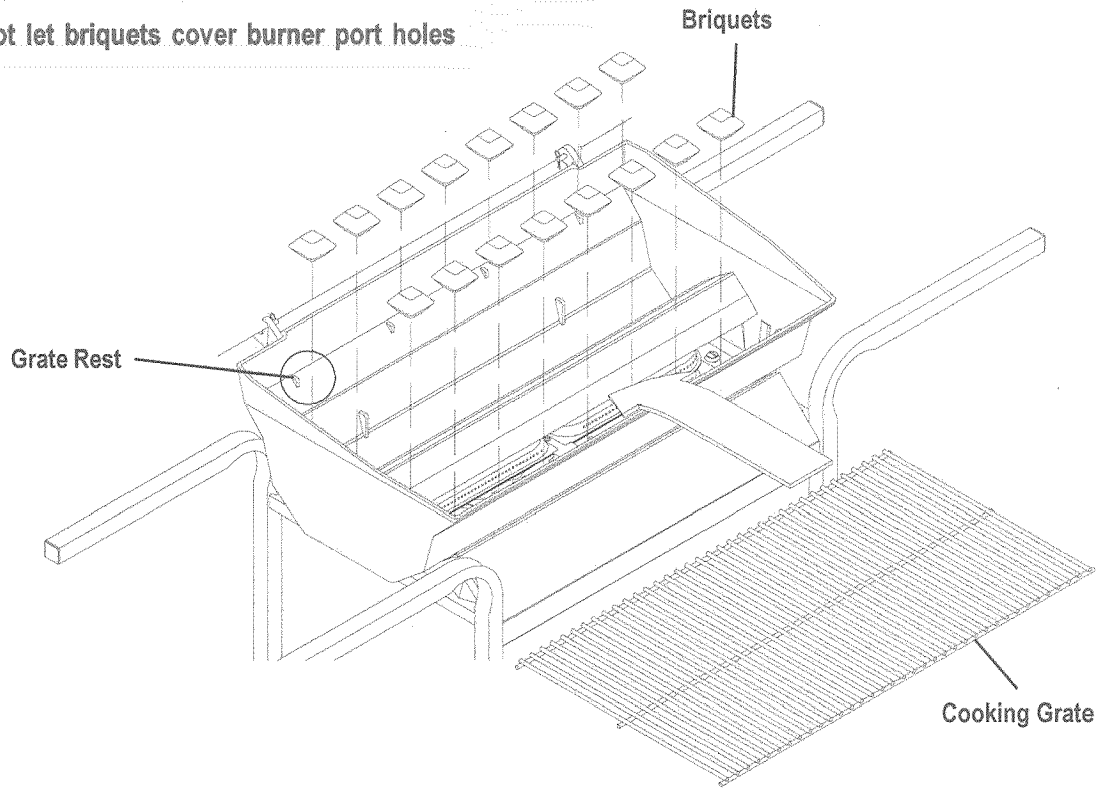



# Recipes

---

## Char-Broil Turkey

Yield: 14 to 16 generous servings or 1 lb. per person

Cooking time: 25 minutes per pound • Method: Grill on low

12 to 14 lb. turkey, thawed completely	vegetable oil
1 large apple, quartered	1 quart water
1-1/2 sticks butter	2 stalks celery, cut in 2" pieces
1 orange, quartered	2 onions, cut in large cubes
1 lemon, thinly sliced or 4 tbs. lemon juice	salt and pepper
cheesecloth (optional)	

Heat grill to medium. Wash and rinse turkey, removing giblets. Dry with absorbent paper. Bend wings back behind turkey. Season inside of turkey with salt and pepper. Rub outside of bird with oil. Stuff with onions, celery, orange and apple. Completely fill cavity (this gives moisture to the turkey). Cover openings of turkey with excess skin. Melt butter in a large aluminum foil pan. Add turkey, water and lemon juice. Place on grill and turn heat to low. Baste with butter, cover top with cheesecloth and baste again. Baste every 1/2 hour until done. Serve with **Giblet Gravy**.

## Giblet Gravy

2 to 3 turkey or chicken giblets	salt and pepper to taste
3-4 tbs. turkey or chicken fat	1/4 tsp. Accent
1/4 cup flour	dash of thyme
2 cups fat-free pan juices	1/8 tsp. Kitchen Bouquet
2 hard boiled eggs, finely chopped	milk, if needed
giblet broth, if needed	

Boil giblets until tender, reserving broth. Chop giblets and set aside. Remove grilled turkey from baking pan and place on hot platter. Pour all pan juices into large measuring cup. Skim off fat, reserving 3 to 4 tbs. Place reserved fat into a deep saucepan, heating over moderate heat. Stir in flour, whisking well with wire whisk. Cook over low heat until bubbly then remove from heat. Add fat-free pan juices (add milk and giblet broth to juices to make 2 full cups). Blend well with wire whisk. Season with salt, pepper, Accent, thyme and Kitchen Bouquet, whisking continuously. Return mixture to heat and continue stirring for 3 to 4 minutes. Add chopped eggs.

## Smoked Turkey Breast

Cooking time: 25 minutes Per Pound • Method: Grill Indirect Heat

1 turkey breast, fresh or thawed	1 large bottle Italian dressing
1 large plastic roasting bag	1 small bottle soy sauce

Mix dressing and soy sauce. Place turkey breast in bag and pour mixture over turkey breast. Marinate in refrigerator overnight. Light one side of grill with setting on low. Remove turkey from marinade and reserve liquid. Put meat thermometer in turkey breast being certain not to touch bone. Place turkey on the grill away from direct heat. Grill over low fire, basting and rotating often. Remove when meat thermometer registers 180°F.

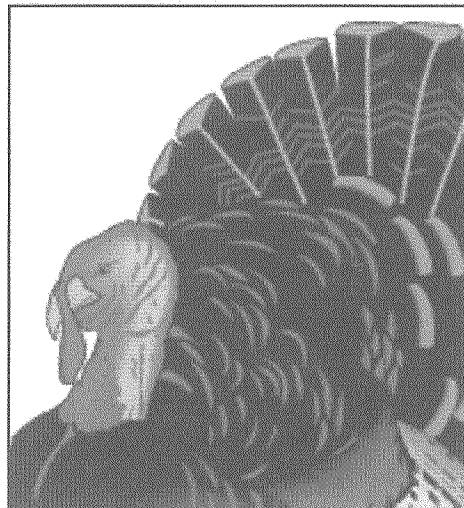



# Recipes

---

## Savory Sirloin Steak

Yield: 4-6 Servings • Cooking Time: 15-25 Minutes • Method: Medium-Hot

1/4 cup Worcestershire sauce	1 (3 lb.) sirloin steak
1 tbs. minced onion	2 tbs. steak sauce
2 tbs. lemon juice	2 tbs. butter, melted
2 tbs. oil	1 tbs. chopped parsley
1 tsp. salt	1 tsp. Worcestershire
1/2 tsp. instant minced garlic	

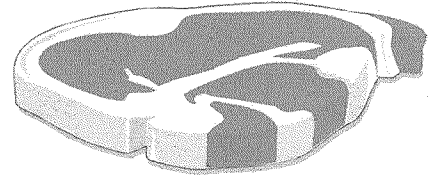

Combine first 6 ingredients. Pour into a heavy plastic bag and add steak. Marinate in refrigerator 4 hours or overnight, turning occasionally. Remove steaks from marinade about 1 hour before grilling. Drain. Place on grill over hot fire. Grill about 8 to 12 minutes on each side, or to desired degree of doneness. Combine remaining ingredients and spoon over steak before serving. Slice steak in thin diagonal slices.

## Teriyaki Steak

Yield: 6-8 Servings • Cooking Time: 30 Minutes • Method: Medium-Hot

1 2 lb. flank steak	1 tsp. ginger	1/4 cup water
1 clove garlic, minced	2 tbs. sugar	2 tsp. meat tenderizer
1/3 cup grated onion	1/2 cup soy sauce	1 tsp. Liquid Smoke

Score steak in diamond pattern on both sides. Place steak in heavy plastic bag. Combine marinade ingredients and pour over steaks. Marinate at room temperature 2 to 3 hours, or in refrigerator overnight, turning occasionally. Allow steak to come to room temperature before grilling. Reserve marinade. Place on grill over medium-hot fire and grill with lid down for 15 minutes, basting often. Turn and grill another 15 minutes or until done to your liking. Continue basting.

## Eye of Round

Yield: 6 Servings • Cooking Time: About 1-1/4 Hours • Method: Low-Medium

1 (3 lb.) eye of round	1/3 cup wine vinegar
2/3 cup Worcestershire sauce	2/3 cup salad oil
1/3 cup soy sauce	

Marinate roast overnight in above mixture. Cook over low fire until done. Check after 1 hour for medium rare. Slice very thin and serve with **Horseradish Sauce**.

## Horseradish Sauce

Yields: 1-1/2 cups

Combine all ingredients in blender.	1 (3 oz.) pkg. cream cheese	2 tbs. horseradish	1 cup sour cream
1/4 tsp. each : sugar, salt and pepper	1 tsp. grated onion		



# Recipes

---

## Indirect Cooking:

You can bake or slowly roast many foods on a covered grill by cooking indirectly. Simply light the gas on one side of the grill and place the food on the other side. Close the lid and your grill will bake or roast like a conventional oven.

### Lemon Herb Chicken

Yield: 6 Servings • Cooking Time: 45 Minutes • Method: Low

1/2 cup fresh lemon juice	Grated rind of 1 lemon
1-1/2 tsp. crushed sweet basil	1/2 tsp. crushed thyme
2 cloves garlic, crushed	2 tsp. salt
1 tsp. paprika	1 cup oil
1-1/2 tsp. onion powder	1 cut up frying chicken

Combine all ingredients and pour into plastic bag. Add chicken and marinate for 6 to 8 hours in refrigerator, turning occasionally. Remove from refrigerator 1 hour before grilling. Place chicken on grill, skin-side up. Cook for 20 to 25 minutes, basting often with marinade. Turn, cook for 20 minutes longer. Serve immediately.

### Polynesian Chicken

Yield: 4 Servings • Cooking Time • 1 to 1-1/2 Hours • Method: Low

2 (2 Lb.) split broilers	2 tsp. salt
1/2 cup oil	1/2 tsp. pepper

Brush chicken with oil and season with salt and pepper. Place on grill with bone side down. Grill slowly. Turn after 20 to 25 minutes and cook about 20 minutes longer. Meanwhile make the below listed glaze.

### Pineapple Glaze

1 cup crushed pineapple, drained and reserve 1/4 cup syrup	2 tbs. prepared mustard
2 tbs. lemon juice	1/2 tsp. salt
	1 cup brown sugar

Combine ingredients, brush both sides of chicken with glaze and broil about 10 minutes more or until tender. Turn and baste with glaze. Serve extra glaze with chicken.

### Chicken Shish Kabobs

Yield: 4 Servings • Cooking Time: 12-16 Minutes • Method: Medium

4 chicken breast halves, boned and cut into 1-1/2 inch pieces	1 cup soy sauce
1 green pepper, cut in 1 inch pieces	1/2 lb. mushrooms
1 zucchini squash sliced and parboiled	1 small can pineapple chunks, juice reserved

Combine all but pineapple chunks (include the pineapple juice). Marinate for 8 to 12 hours in refrigerator. Thread chicken, pineapple, mushrooms and bell pepper alternately on skewers. Grill over medium fire for 6 to 8 minutes on each side or until done.

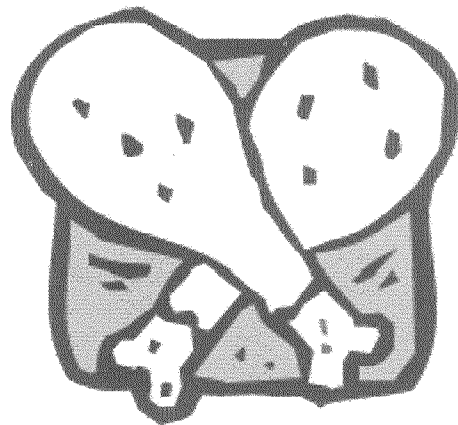

**For the repair or replacement parts you need  
delivered directly to your home**

Call 7 am - 7 pm, 7 days a week

**1-800-366-PART**

(1-800-366-7278)

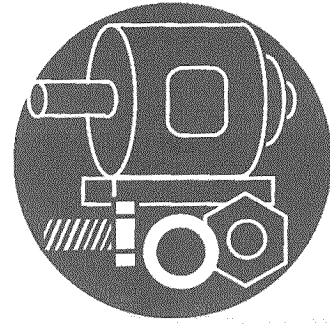

**For in-home major brand repair service**

Call 24 hours a day, 7 days a week

**1-800-4-REPAIR**

(1-800-473-7247)

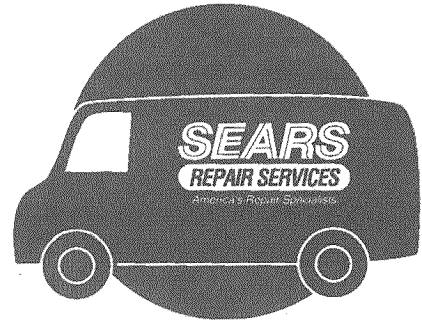

**For the location of a  
Sears Parts and Repair Center in your area**

Call 24 hours a day, 7 days a week

**1-800-488-1222**

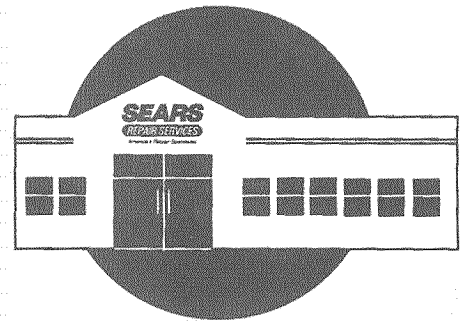

**For information on purchasing a Sears  
Maintenance Agreement or to inquire  
about an existing Agreement**

Call 9 am - 5 pm, Monday-Saturday

**1-800-827-6655**



When ordering repair parts always give the following  
information:

- Model Number
- Part Number
- Name of Item
- Part Description





SAVE FOR FUTURE REFERENCE

4637037 / 0-4164588 (12-2-99)

## OWNER'S MANUAL

Model No. 415.154060



**Caution:**  
Read and follow all  
**Safety Statements,**  
**Assembly Instructions,**  
**and Use and Care**  
**Directions** *before*  
attempting to assemble  
and cook.

**Installer / assembler:** Leave  
these instructions with  
consumer.

**To Consumer:** Keep this  
manual for future reference.

 **Some parts may  
contain sharp edges,**  
**especially as noted in the**  
**manual! Wear protective**  
**gloves if necessary.**

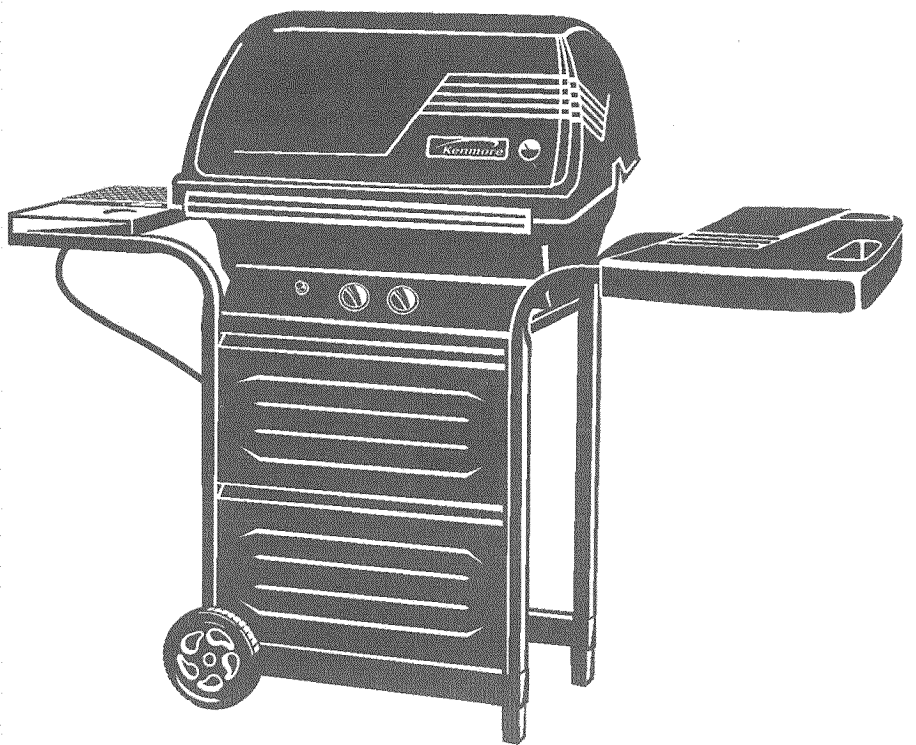

## LP GAS GRILL

- Assembly Instructions
- Parts List  
Parts Diagram

If you have questions or need assistance during assembly, please call 1-800-241-7548. You will be speaking to a representative of the grill manufacturer and not a Sears employee. If you would like to order replacement parts, please contact Sears at 1-800-366-PART as noted on the back of this manual.

**This Grill is for Outdoor Use Only**

**Sears, Roebuck and Co., Hoffman Estates, IL 60179 U.S.A**

Key	Qty	Description	Part #
1	2	Leg Assembly	4502044
2	2	Leg Extender	4156109
3	2	Rail	4503058
4	7	#10-24x1-1/2 Mach Screw	4080303
5	14	#10-24 Hex Nut (keys)	4080208
6	1	Tank Support Bracket	4502040
7	3	#10-24x3/8 Mach Screw	4080379
		STD511003	
8	4	End Cap	4080642
9	2	Wheel	4156956
10	2	5/16 Axle Bolt	4080155
11	4	3/4 Hitch Pin	4156515
12	8	#10x1/2 Self-Tap Screw	4080652
13	2	Fixed Panel	4503880
14	4	Push Fastener	4080675
15	1	Console	4525420
16	1	Valve/Hose/Regulator	4524315
17	1	Grill Bottom	4581968
18	1	Grease Clip	5156607
19	2	1/4-20x1-1/2 Mach Screw	4080324
		STD512515	
20	2	1/4-20 Hex Nut	4080656
21	1	Burner Assembly	4505008
22	1	Briquet Grate	4157101
23	1	Collector Box	4501543
24	1	Electrode	5156119
25	1	#6x3/8 Self-Tap Screw	4080264
26	1	Ignitor Wire	4153720
27	1	Drip VaporISER Bar	4156417
28	1	Side Shelf	4154283
29	5	#10x1-1/2 Screw	4080756
30	1	Grill Lid	4581045
31	2	1/4x1-1/8 Hinge Pin	4156513
32	1	Logo Plate	4156081
33	2	3/16 Pal Nut	4153096
34	1	Heat Indicator w/Bracket	4156800
35	1	Handle	4059000
36	2	#10-24x3-1/2 Mach Screw	4080307
37	2	Handle Spacer	5069502
38	2	Insulated Washer	4080418
39	1	SwingAway	4152124
40	1	Sideburner Body	4525153
41	1	Sideburner Frame	4501705
42	2	#6-32x3/8 Mach Screw	4080361
		STD510603	
43	1	Sideburner Valve Bracket	4501709
44	2	#10-24x3/8 Mach Screw	4080696
45	1	Sideburner Burner	4068076
46	1	Sideburner Ignitor Wire	5156109
47	1	Sideburner Grate	4156376
48	1	Sideburner Knob	4154248
49	1	Ignitor	5156113
50	2	Control Knob	4154203
51	1	Tank Wire	4154195
52	---	Briquets	4159300
53	1	Cooking Grate	4152739

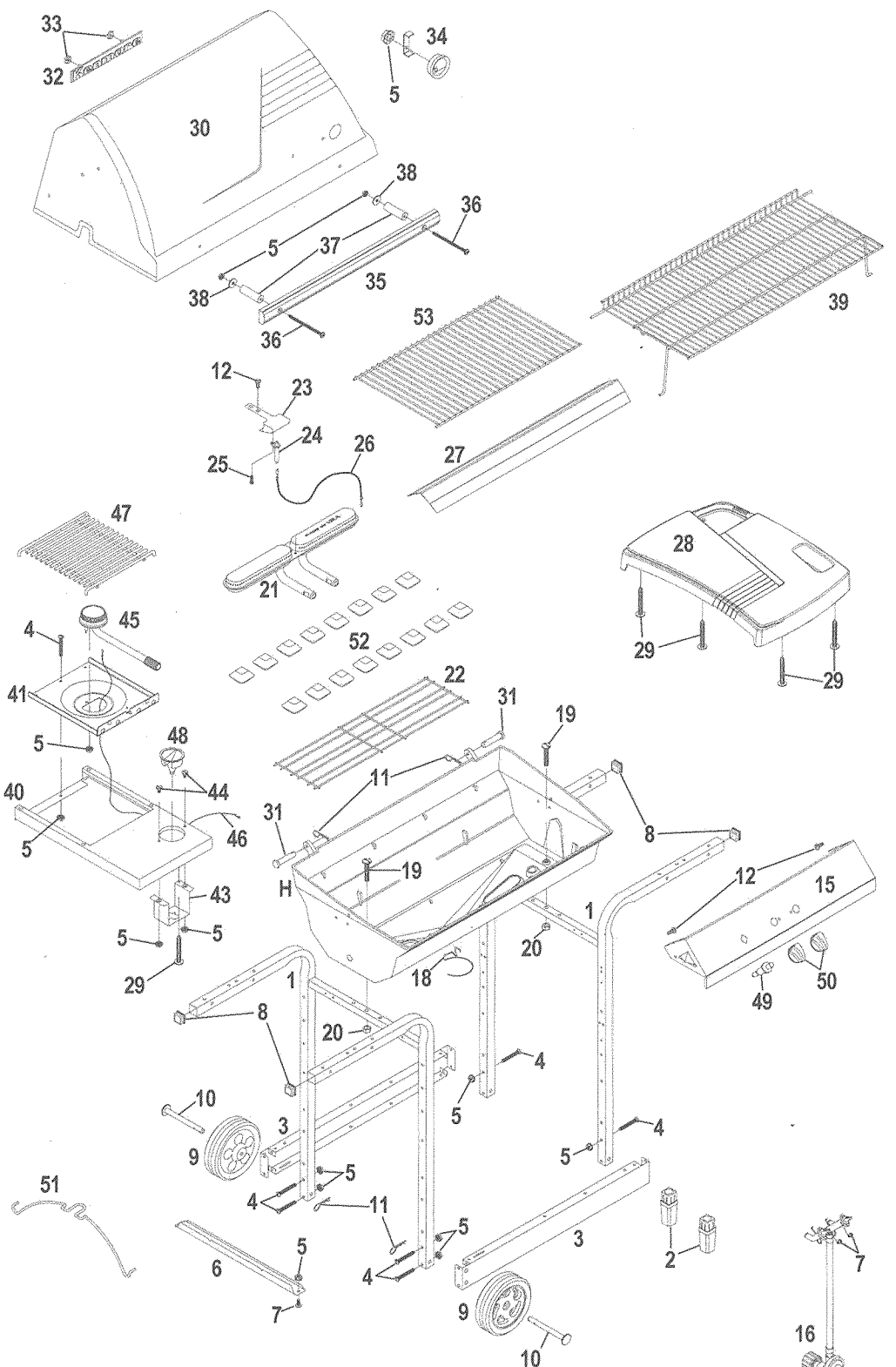

### Before Beginning Assembly

- Necessary tools for assembly of your grill include: screwdrivers (flathead and Phillips®), hammer, pliers and adjustable wrench. A 3/8" and 7/16" nut driver would be ideal.

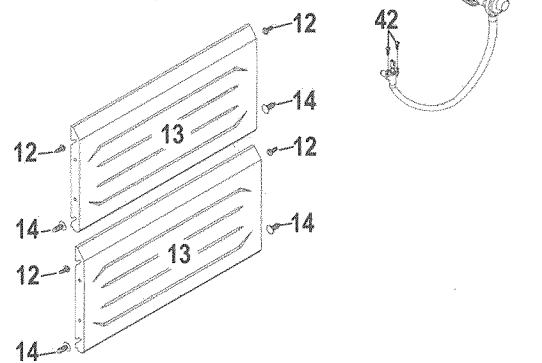
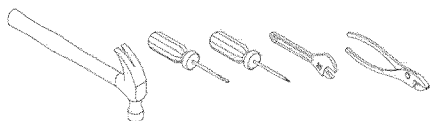

**1**

**NOTE:** Rail with label has the serial and model number for your grill. Write this information on Page 2 of your Use and Care in the "Warranty Information" box.

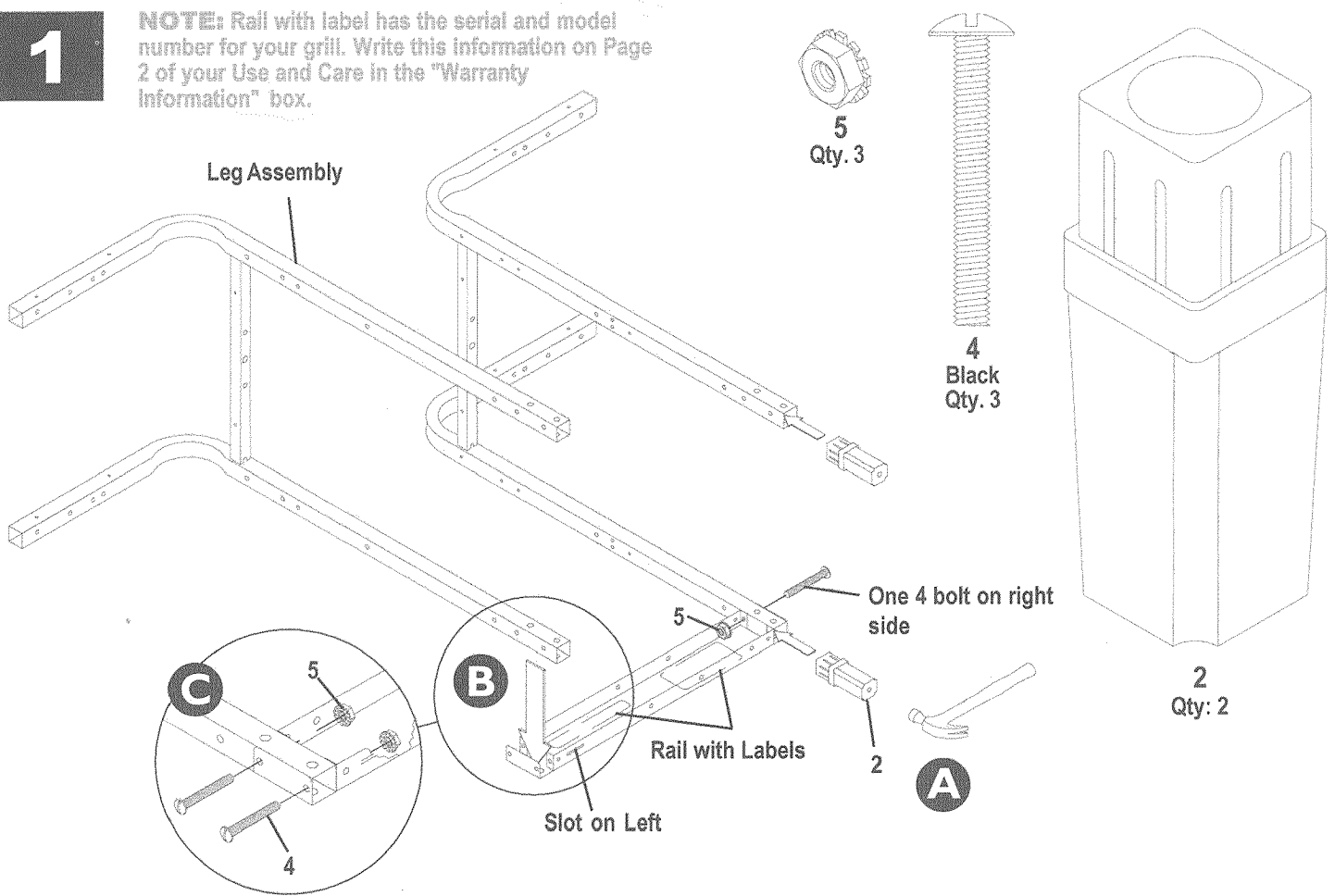

**2**

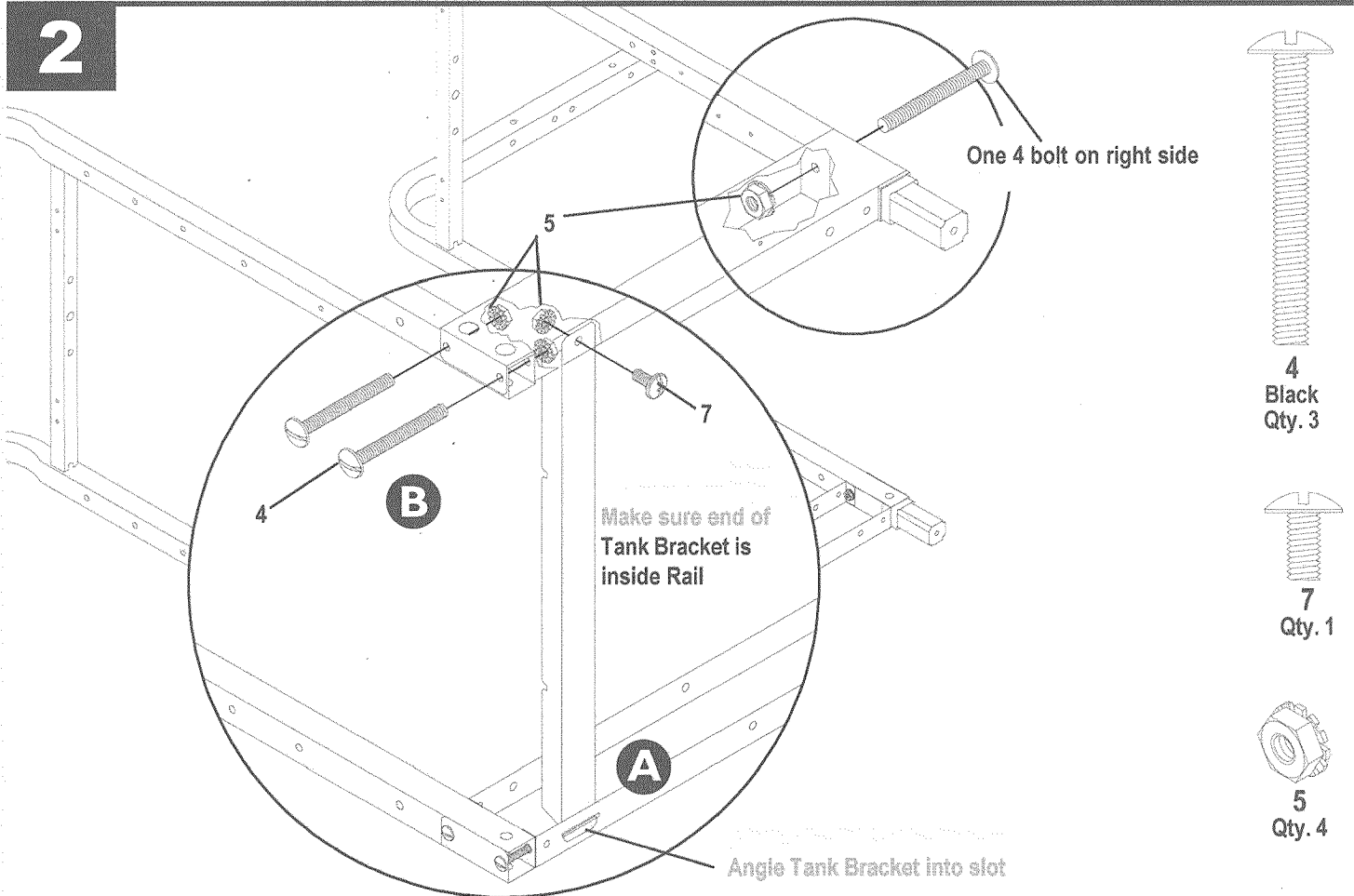

**3**

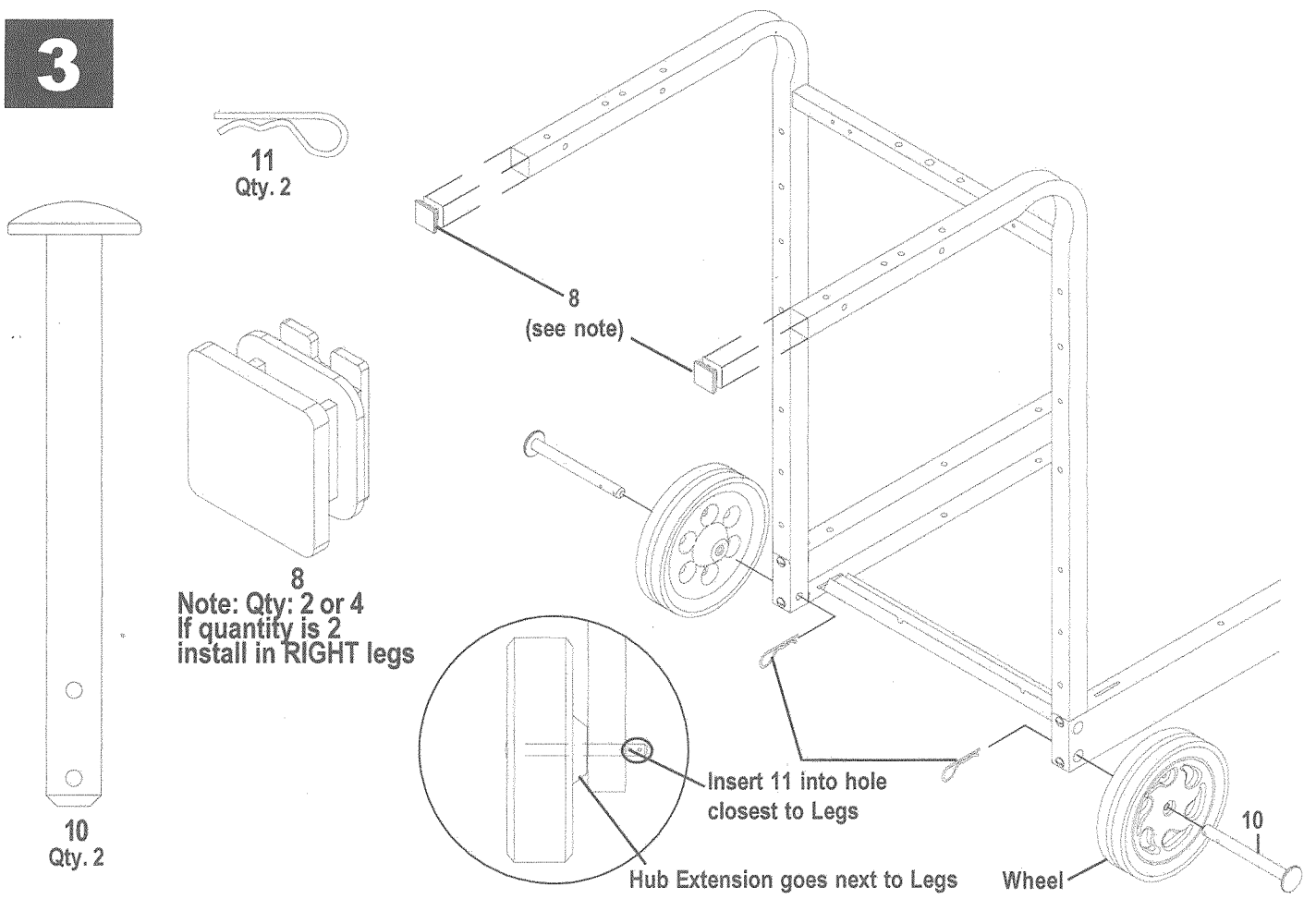

**4**

▲ Fully tighten after Console is attached

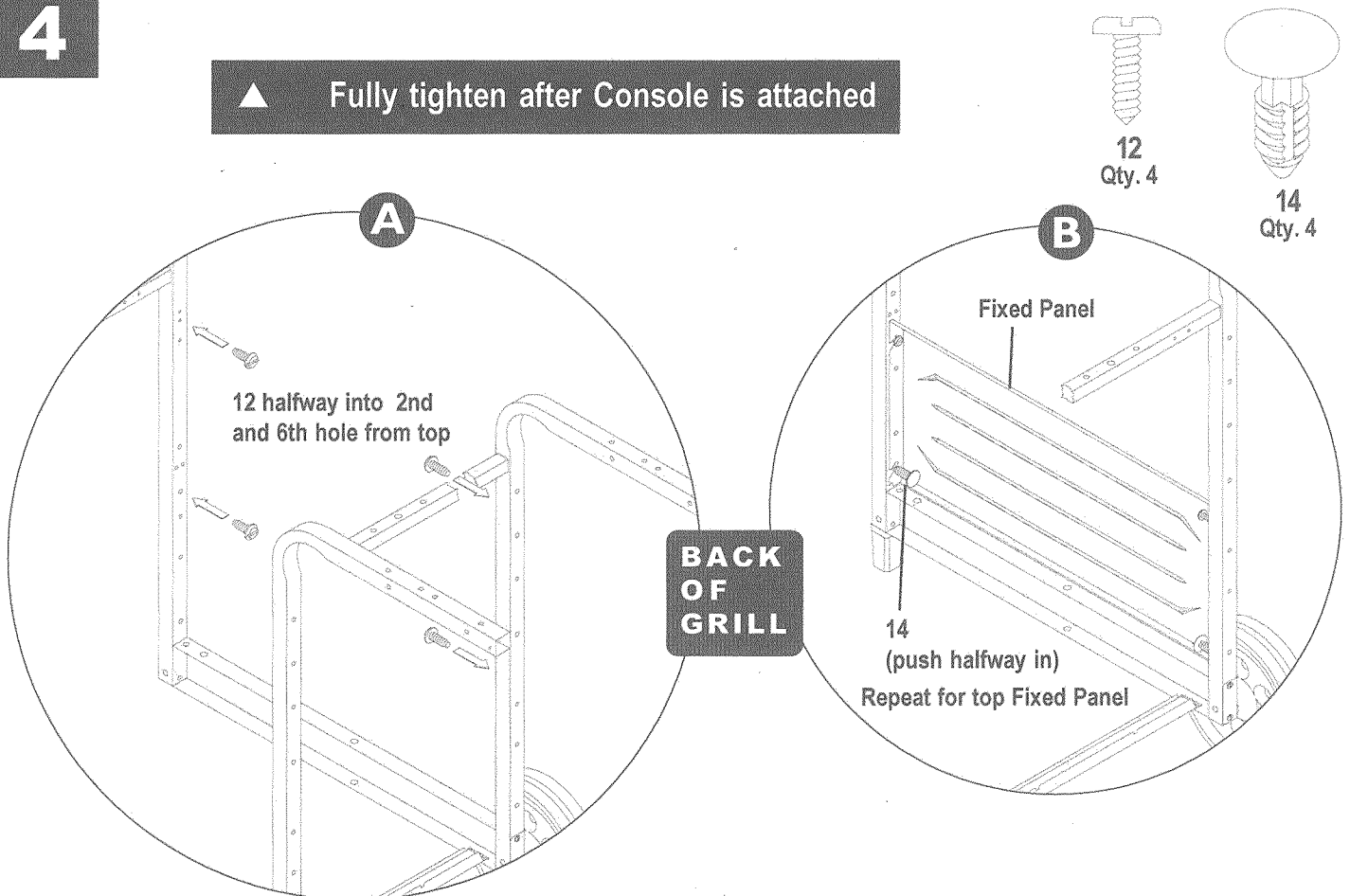

5



▲ Fully tighten screws on the fixed panels.

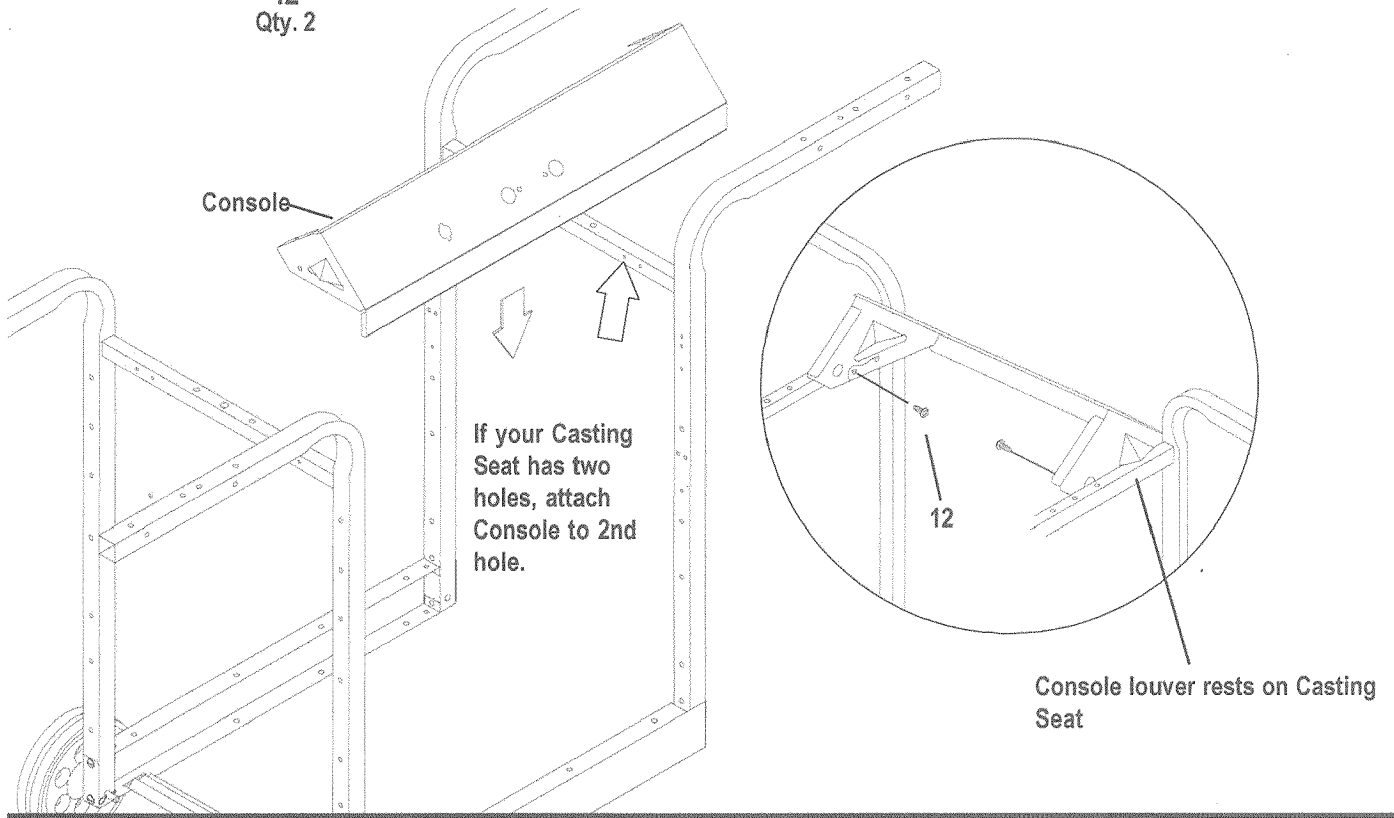

6

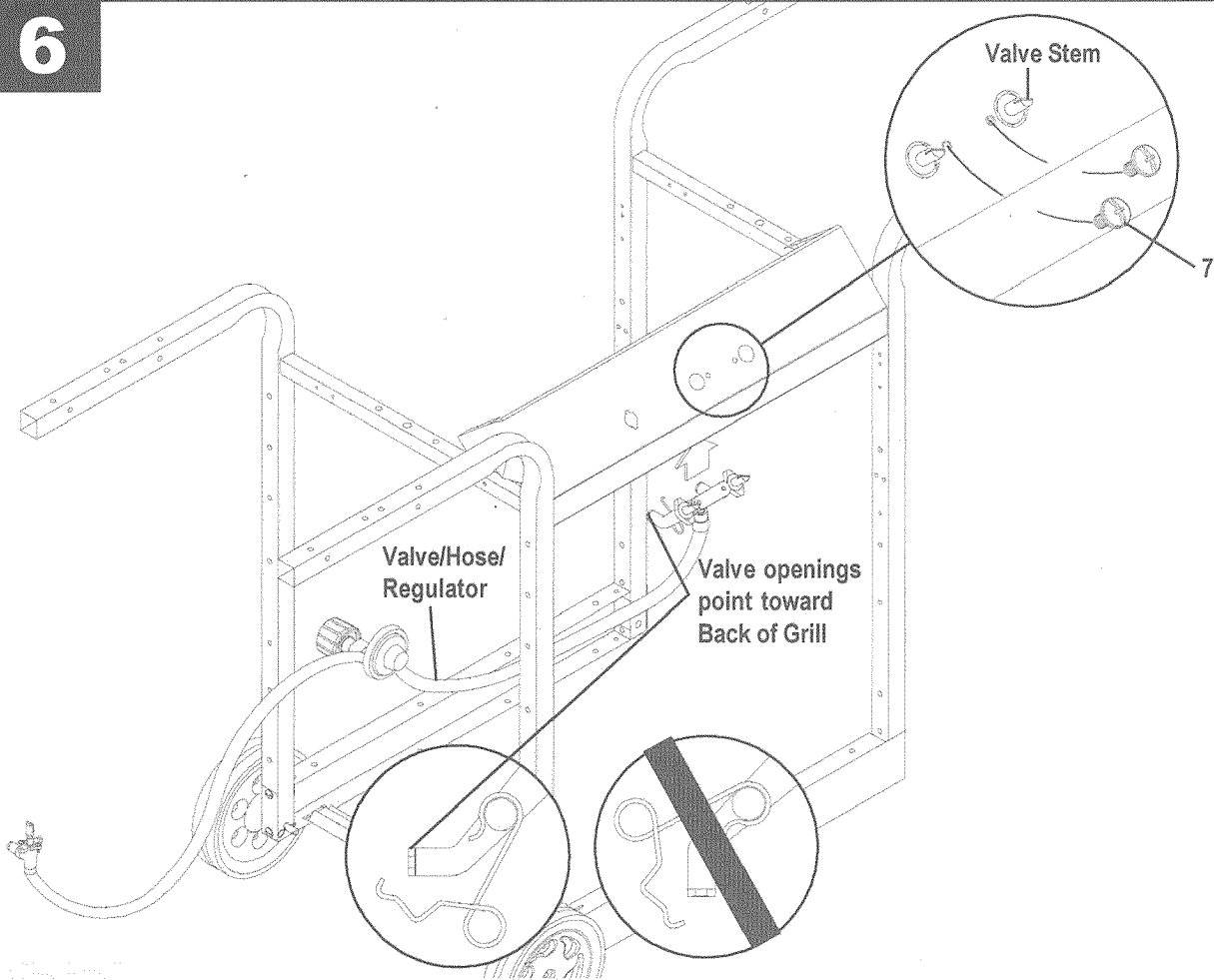
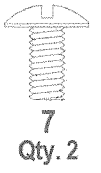

7

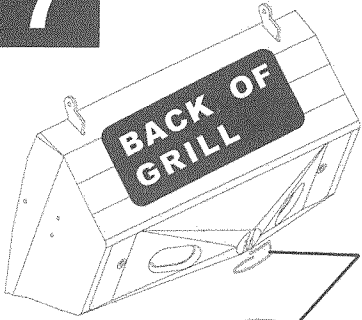

A

Grease Clip

▲ Use an empty soup can to hang from the Grease Clip.

### ▲ CAUTION

- Failure to install can in clip will cause hot grease to drip from bottom of grill with risk of fire or property damage.

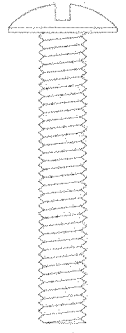
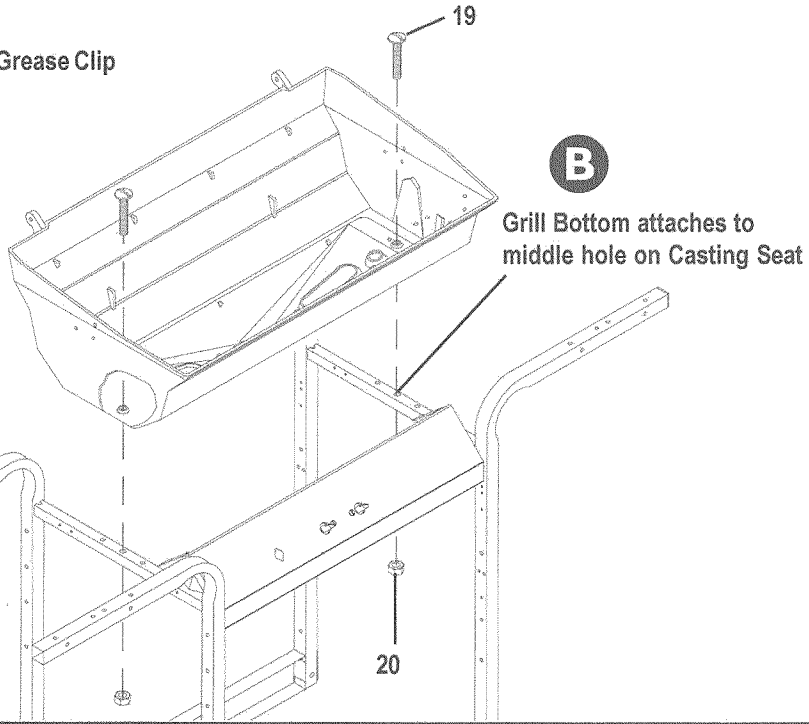

19  
Qty. 2



20  
Qty. 2

8

▲ VERY IMPORTANT:  
Burner tubes must pass through holes in grill bottom and engage valve attached to console.

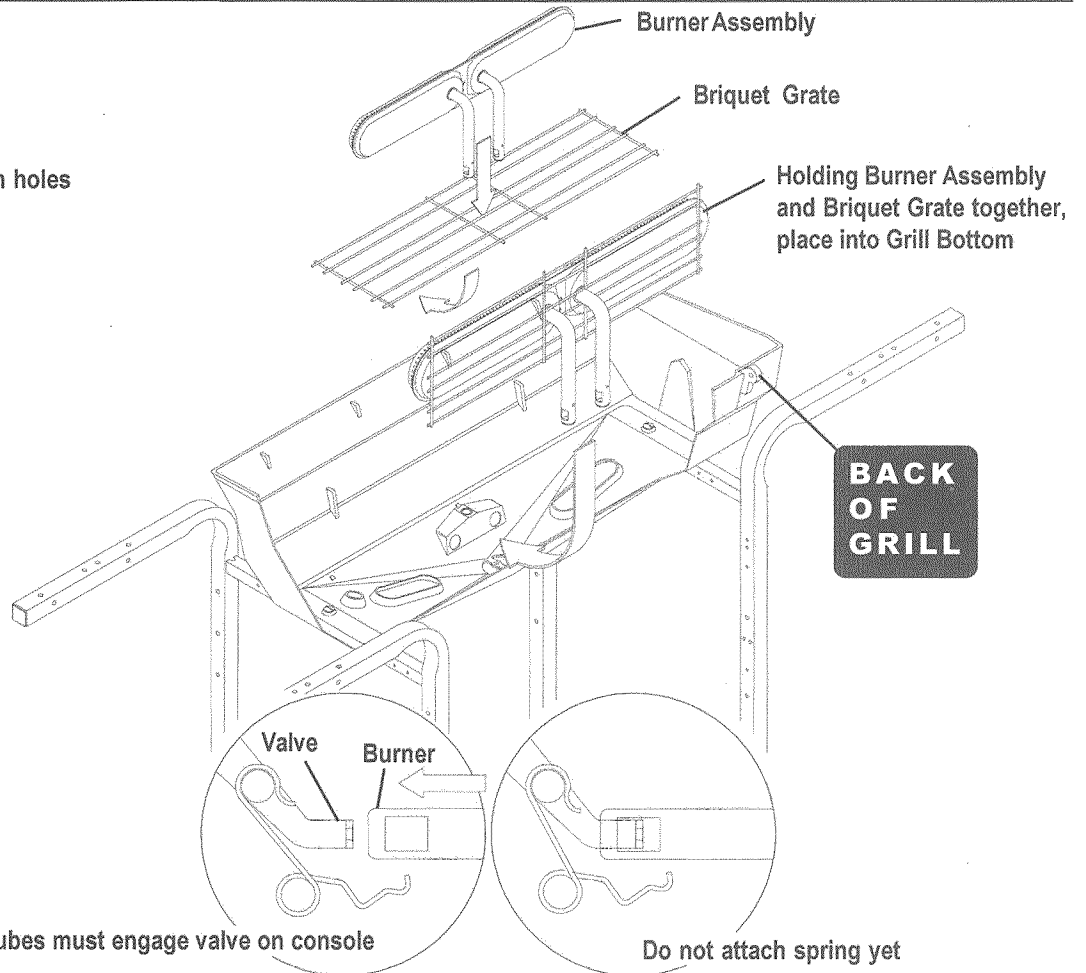

# 9

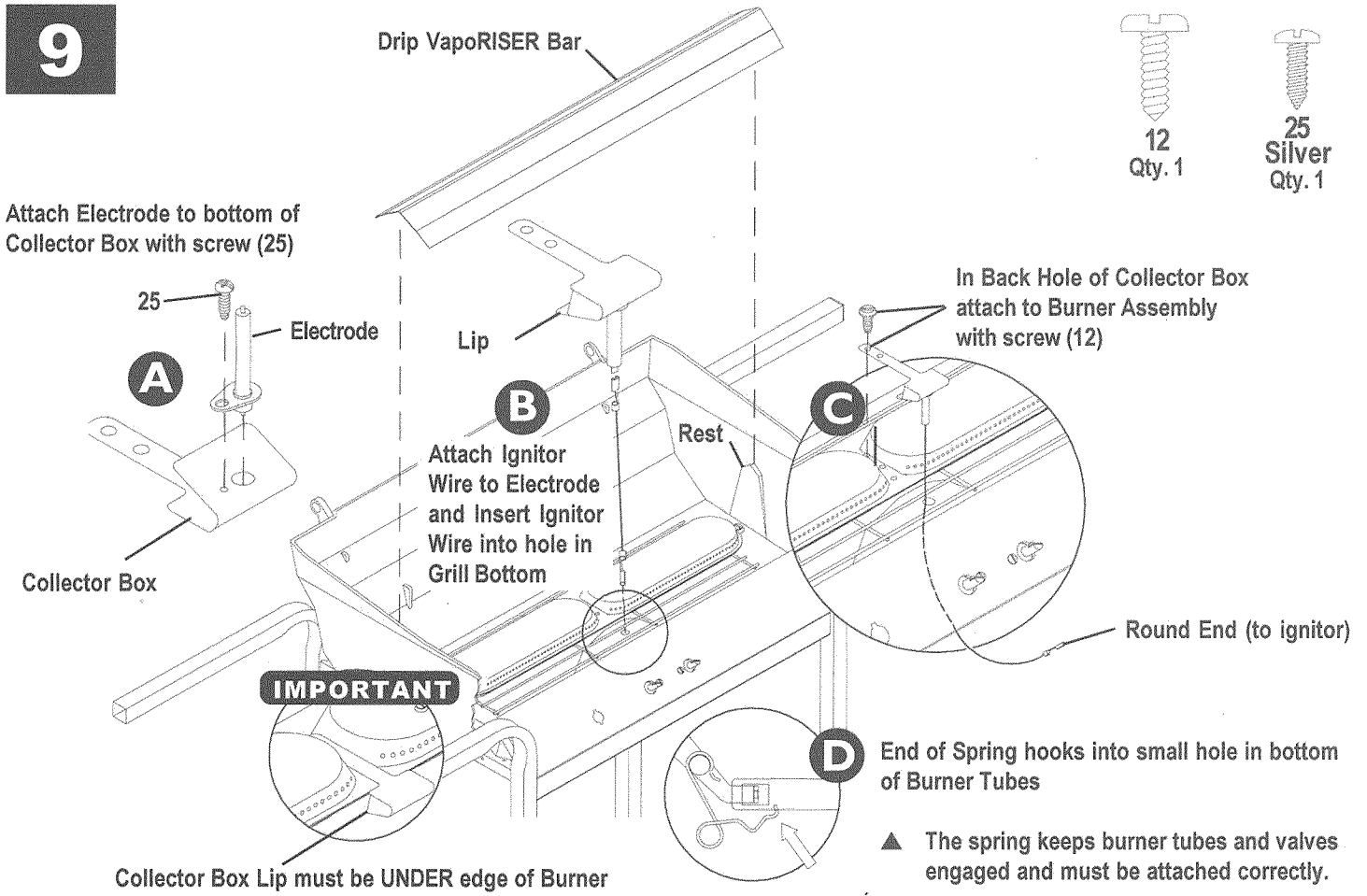

# 10

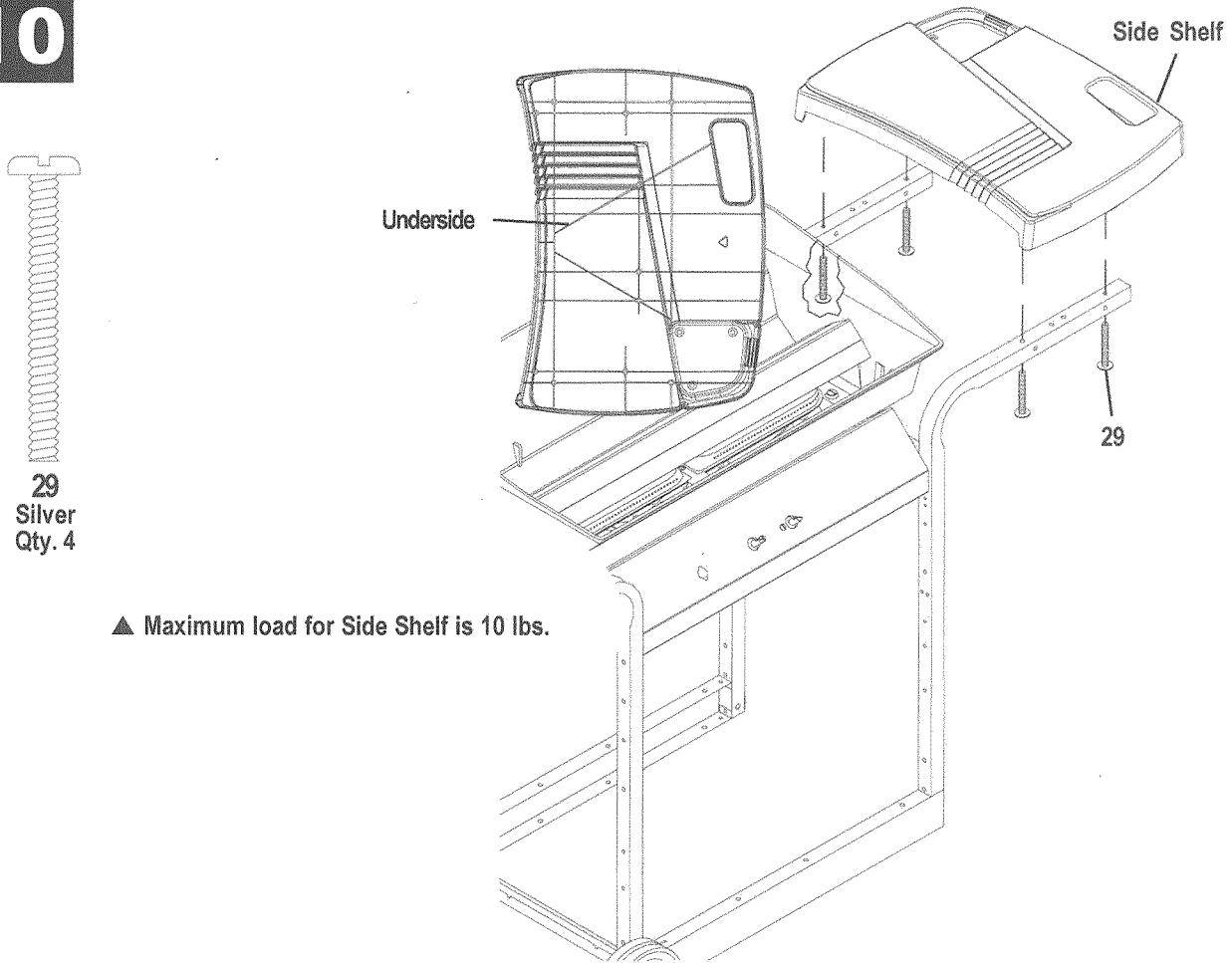

# 11

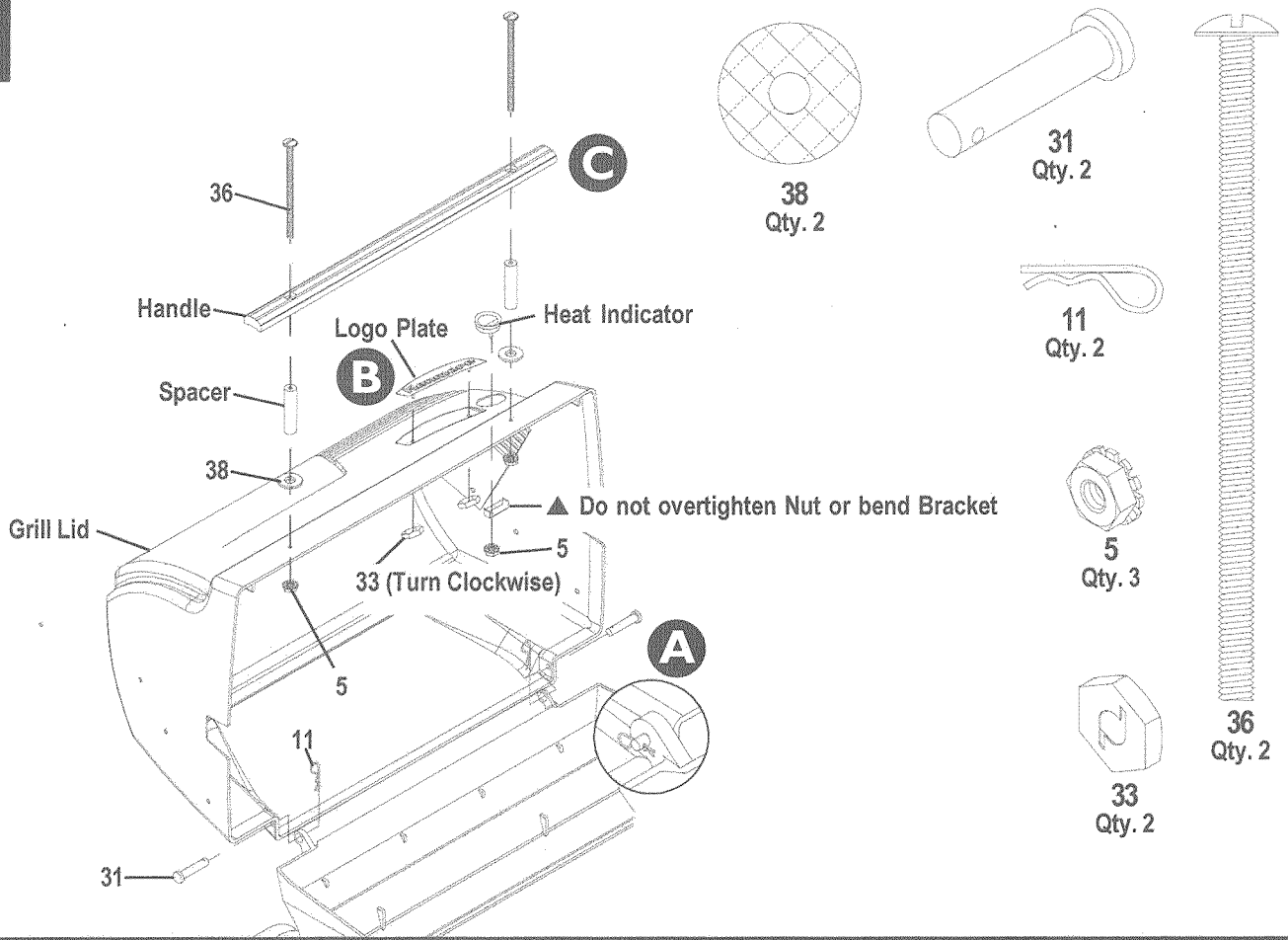

# 12

- ▲ SwingAway will keep food warm, while keeping it away from flames. Do not use SwingAway for cooking meats or heavy food items.
- ▲ Pivot and leg wires must run underneath SwingAway surface.

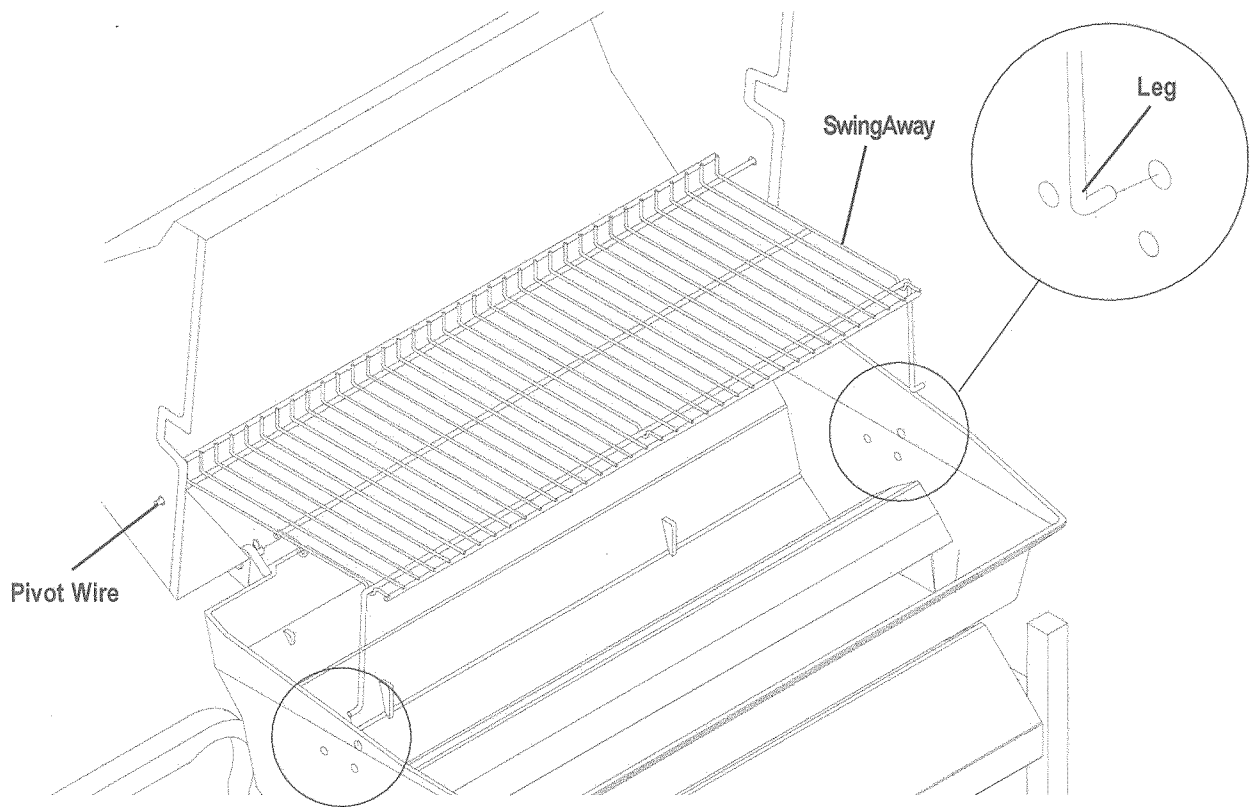





# 15

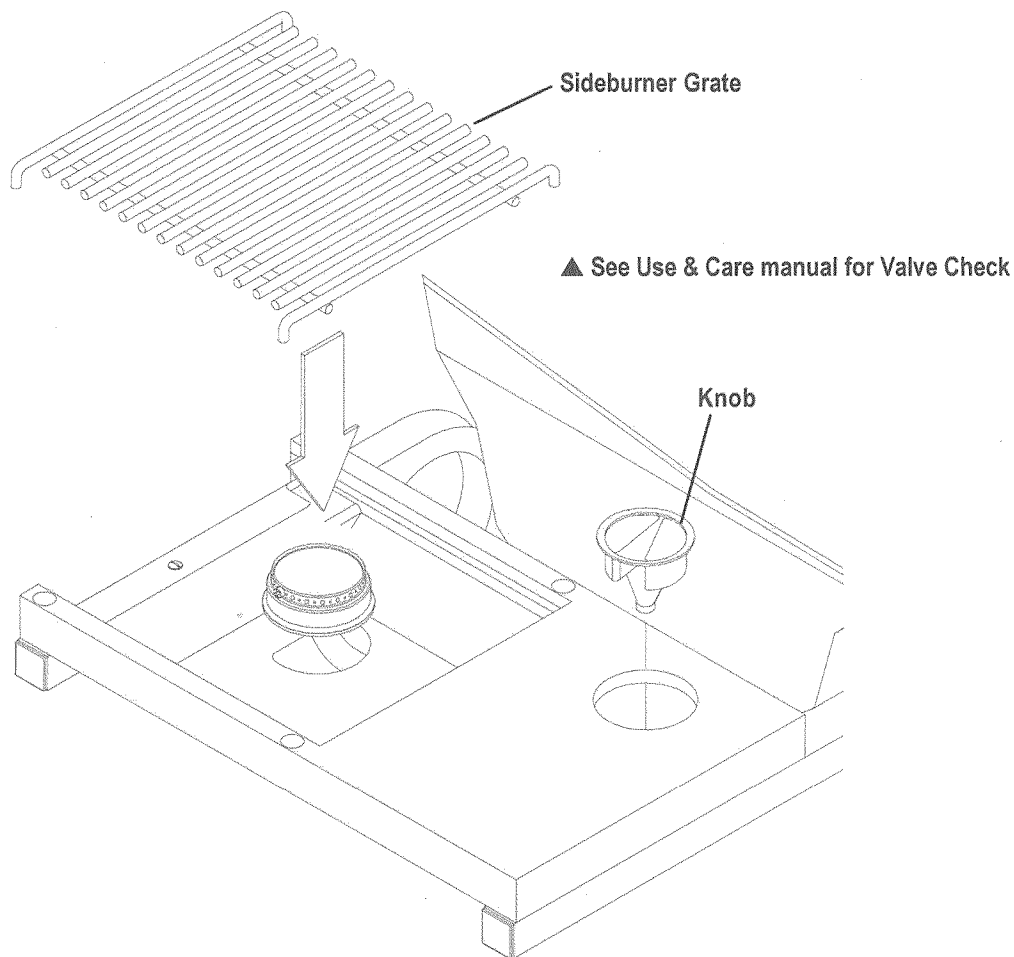

# 16

- ▲ When installing Ignitor do not push on button. This may cause a minor shock.
- ▲ Sideburner electrode wire must be connected to Ignitor for grill and Sideburner to ignite.
- ▲ Ignitor Wire(s) must not come into contact with grill bottom.
- ▲ See Use and Care for Valve Check.

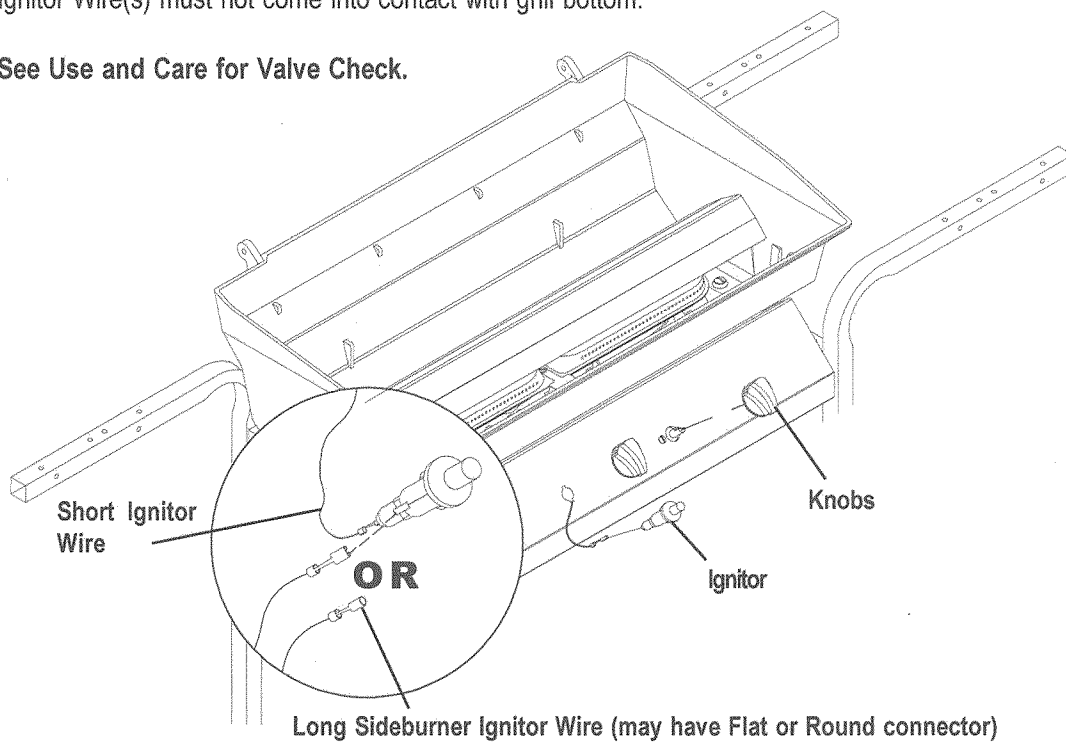

# 17

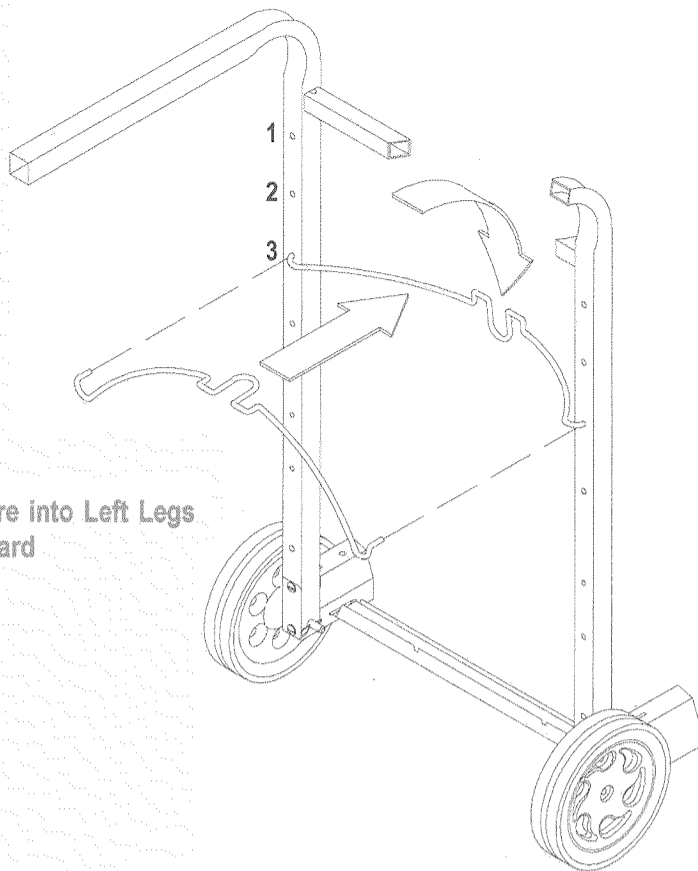

Insert Tank Wire into Left Legs and rotate inward

# 18

▲ LP tank is sold separately. Fill before attaching to grill.

▲ Curved portion of tank wire should be to inside of tank collar.

▲ For filling of tank and connection of tank to regulator, see the Use and Care Manual.

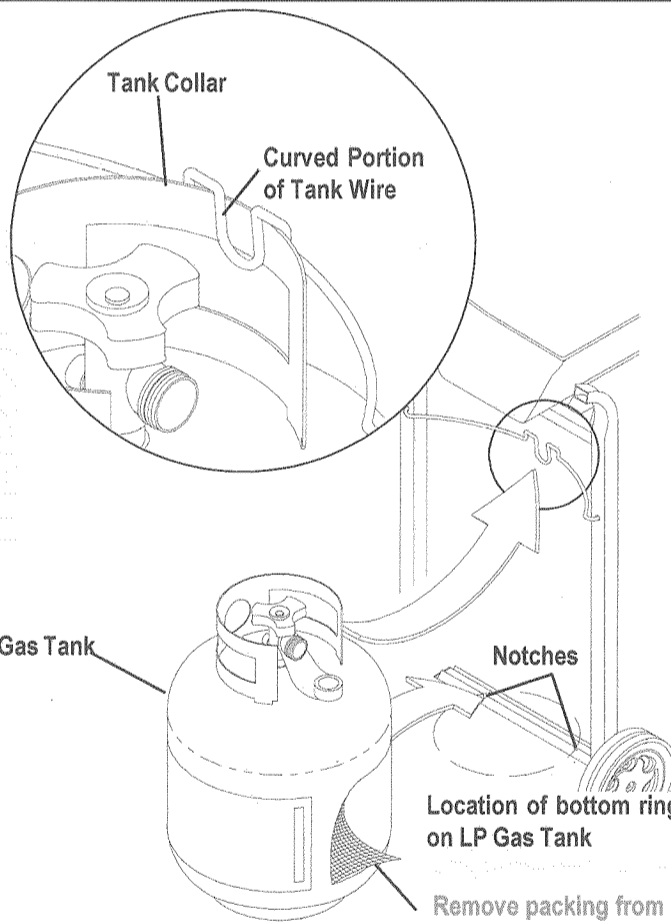

## ▲ CAUTION

- Tank collar opening must face to front of cart once tank is attached.
- Failure to install tank correctly may allow gas hose to be damaged in operation.

**See Use and Care Manual for important safety instructions before using.**

# 19

Perform the "Burner Flame Check" in the Use and Care section.

▲ Let grill cool before placing briquets.

Place 16 briquets. Do not layer or stack just enough to cover fire grate surface.

▲ Do not let briquets cover burner port holes

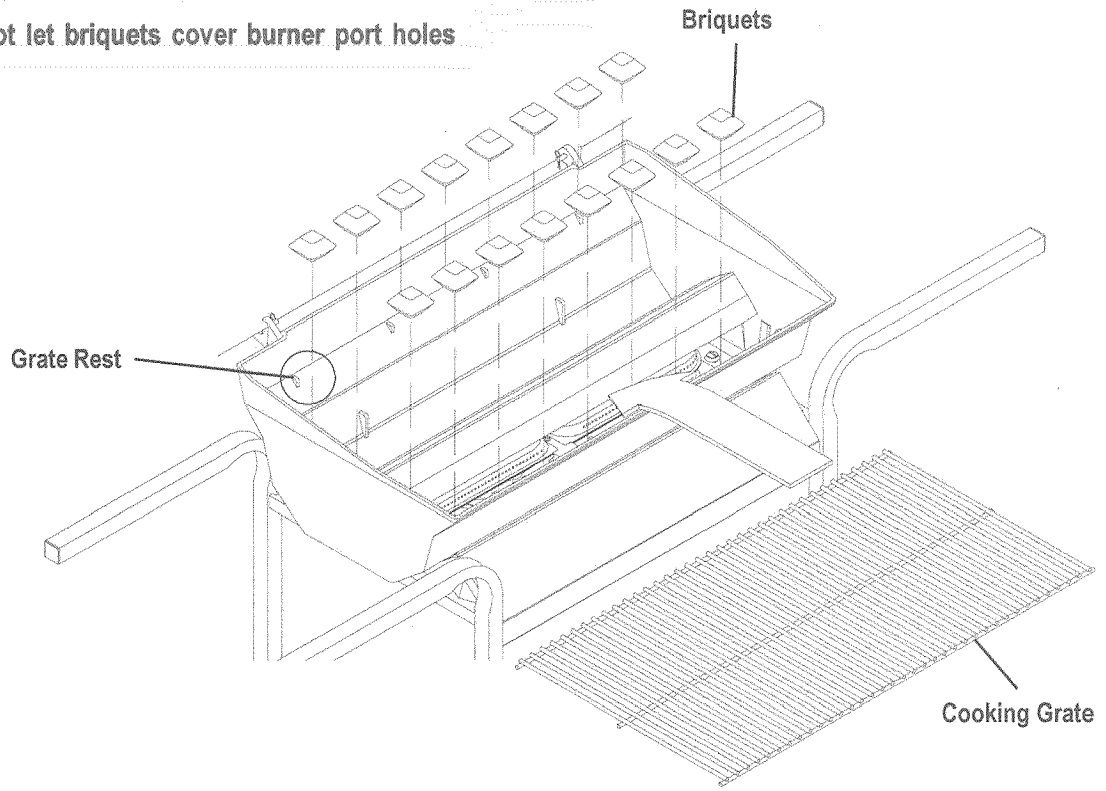



# Recipes

---

## Char-Broil Turkey

Yield: 14 to 16 generous servings or 1 lb. per person

Cooking time: 25 minutes per pound • Method: Grill on low

12 to 14 lb. turkey, thawed completely	vegetable oil
1 large apple, quartered	1 quart water
1-1/2 sticks butter	2 stalks celery, cut in 2" pieces
1 orange, quartered	2 onions, cut in large cubes
1 lemon, thinly sliced or 4 tbs. lemon juice	salt and pepper
cheesecloth (optional)	

Heat grill to medium. Wash and rinse turkey, removing giblets. Dry with absorbent paper. Bend wings back behind turkey. Season inside of turkey with salt and pepper. Rub outside of bird with oil. Stuff with onions, celery, orange and apple. Completely fill cavity (this gives moisture to the turkey). Cover openings of turkey with excess skin. Melt butter in a large aluminum foil pan. Add turkey, water and lemon juice. Place on grill and turn heat to low. Baste with butter, cover top with cheesecloth and baste again. Baste every 1/2 hour until done. Serve with **Giblet Gravy**.

## Giblet Gravy

2 to 3 turkey or chicken giblets	salt and pepper to taste
3-4 tbs. turkey or chicken fat	1/4 tsp. Accent
1/4 cup flour	dash of thyme
2 cups fat-free pan juices	1/8 tsp. Kitchen Bouquet
2 hard boiled eggs, finely chopped	milk, if needed
giblet broth, if needed	

Boil giblets until tender, reserving broth. Chop giblets and set aside. Remove grilled turkey from baking pan and place on hot platter. Pour all pan juices into large measuring cup. Skim off fat, reserving 3 to 4 tbs. Place reserved fat into a deep saucepan, heating over moderate heat. Stir in flour, whisking well with wire whisk. Cook over low heat until bubbly then remove from heat. Add fat-free pan juices (add milk and giblet broth to juices to make 2 full cups). Blend well with wire whisk. Season with salt, pepper, Accent, thyme and Kitchen Bouquet, whisking continuously. Return mixture to heat and continue stirring for 3 to 4 minutes. Add chopped eggs.

## Smoked Turkey Breast

Cooking time: 25 minutes Per Pound • Method: Grill Indirect Heat

1 turkey breast, fresh or thawed	1 large bottle Italian dressing
1 large plastic roasting bag	1 small bottle soy sauce

Mix dressing and soy sauce. Place turkey breast in bag and pour mixture over turkey breast. Marinate in refrigerator overnight. Light one side of grill with setting on low. Remove turkey from marinade and reserve liquid. Put meat thermometer in turkey breast being certain not to touch bone. Place turkey on the grill away from direct heat. Grill over low fire, basting and rotating often. Remove when meat thermometer registers 180°F.

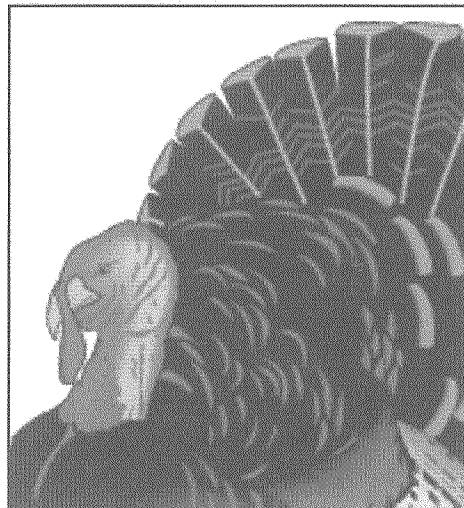



# Recipes

---

## Savory Sirloin Steak

Yield: 4-6 Servings • Cooking Time: 15-25 Minutes • Method: Medium-Hot

1/4 cup Worcestershire sauce	1 (3 lb.) sirloin steak
1 tbs. minced onion	2 tbs. steak sauce
2 tbs. lemon juice	2 tbs. butter, melted
2 tbs. oil	1 tbs. chopped parsley
1 tsp. salt	1 tsp. Worcestershire
1/2 tsp. instant minced garlic	

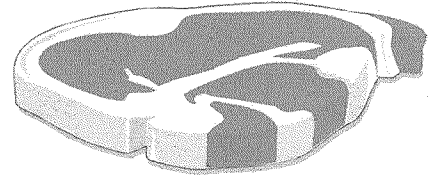

Combine first 6 ingredients. Pour into a heavy plastic bag and add steak. Marinate in refrigerator 4 hours or overnight, turning occasionally. Remove steaks from marinade about 1 hour before grilling. Drain. Place on grill over hot fire. Grill about 8 to 12 minutes on each side, or to desired degree of doneness. Combine remaining ingredients and spoon over steak before serving. Slice steak in thin diagonal slices.

## Teriyaki Steak

Yield: 6-8 Servings • Cooking Time: 30 Minutes • Method: Medium-Hot

1 2 lb. flank steak	1 tsp. ginger	1/4 cup water
1 clove garlic, minced	2 tbs. sugar	2 tsp. meat tenderizer
1/3 cup grated onion	1/2 cup soy sauce	1 tsp. Liquid Smoke

Score steak in diamond pattern on both sides. Place steak in heavy plastic bag. Combine marinade ingredients and pour over steaks. Marinate at room temperature 2 to 3 hours, or in refrigerator overnight, turning occasionally. Allow steak to come to room temperature before grilling. Reserve marinade. Place on grill over medium-hot fire and grill with lid down for 15 minutes, basting often. Turn and grill another 15 minutes or until done to your liking. Continue basting.

## Eye of Round

Yield: 6 Servings • Cooking Time: About 1-1/4 Hours • Method: Low-Medium

1 (3 lb.) eye of round	1/3 cup wine vinegar
2/3 cup Worcestershire sauce	2/3 cup salad oil
1/3 cup soy sauce	

Marinate roast overnight in above mixture. Cook over low fire until done. Check after 1 hour for medium rare. Slice very thin and serve with **Horseradish Sauce**.

## Horseradish Sauce

Yields: 1-1/2 cups

Combine all ingredients in blender.	1 (3 oz.) pkg. cream cheese	2 tbs. horseradish	1 cup sour cream
1/4 tsp. each : sugar, salt and pepper	1 tsp. grated onion		



# Recipes

---

## Indirect Cooking:

You can bake or slowly roast many foods on a covered grill by cooking indirectly. Simply light the gas on one side of the grill and place the food on the other side. Close the lid and your grill will bake or roast like a conventional oven.

## Lemon Herb Chicken

Yield: 6 Servings • Cooking Time: 45 Minutes • Method: Low

1/2 cup fresh lemon juice	Grated rind of 1 lemon
1-1/2 tsp. crushed sweet basil	1/2 tsp. crushed thyme
2 cloves garlic, crushed	2 tsp. salt
1 tsp. paprika	1 cup oil
1-1/2 tsp. onion powder	1 cut up frying chicken

Combine all ingredients and pour into plastic bag. Add chicken and marinate for 6 to 8 hours in refrigerator, turning occasionally. Remove from refrigerator 1 hour before grilling. Place chicken on grill, skin-side up. Cook for 20 to 25 minutes, basting often with marinade. Turn, cook for 20 minutes longer. Serve immediately.

## Polynesian Chicken

Yield: 4 Servings • Cooking Time • 1 to 1-1/2 Hours • Method: Low

2 (2 Lb.) split broilers	2 tsp. salt
1/2 cup oil	1/2 tsp. pepper

Brush chicken with oil and season with salt and pepper. Place on grill with bone side down. Grill slowly. Turn after 20 to 25 minutes and cook about 20 minutes longer. Meanwhile make the below listed glaze.

## Pineapple Glaze

1 cup crushed pineapple, drained and reserve 1/4 cup syrup	2 tbs. prepared mustard
2 tbs. lemon juice	1/2 tsp. salt
	1 cup brown sugar

Combine ingredients, brush both sides of chicken with glaze and broil about 10 minutes more or until tender. Turn and baste with glaze. Serve extra glaze with chicken.

## Chicken Shish Kabobs

Yield: 4 Servings • Cooking Time: 12-16 Minutes • Method: Medium

4 chicken breast halves, boned and cut into 1-1/2 inch pieces	1 cup soy sauce
1 green pepper, cut in 1 inch pieces	1/2 lb. mushrooms
1 zucchini squash sliced and parboiled	1 small can pineapple chunks, juice reserved

Combine all but pineapple chunks (include the pineapple juice). Marinate for 8 to 12 hours in refrigerator. Thread chicken, pineapple, mushrooms and bell pepper alternately on skewers. Grill over medium fire for 6 to 8 minutes on each side or until done.

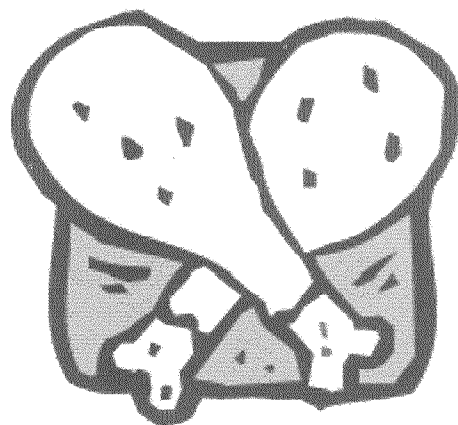

**For the repair or replacement parts you need  
delivered directly to your home**

Call 7 am - 7 pm, 7 days a week

**1-800-366-PART**

(1-800-366-7278)

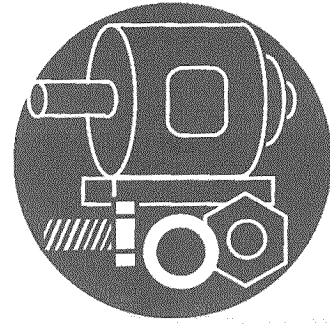

**For in-home major brand repair service**

Call 24 hours a day, 7 days a week

**1-800-4-REPAIR**

(1-800-473-7247)

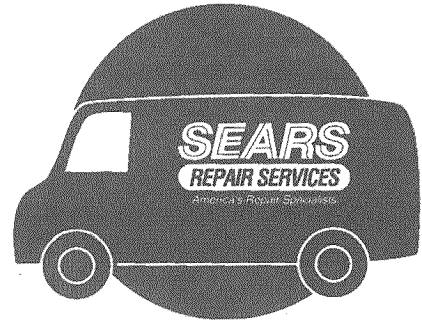

**For the location of a  
Sears Parts and Repair Center in your area**

Call 24 hours a day, 7 days a week

**1-800-488-1222**

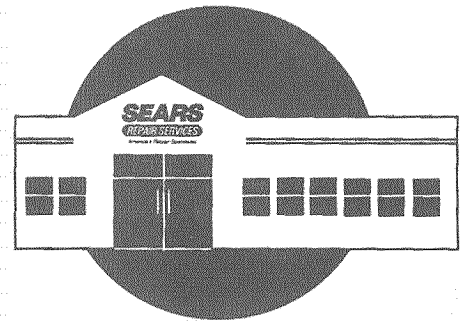

**For information on purchasing a Sears  
Maintenance Agreement or to inquire  
about an existing Agreement**

Call 9 am - 5 pm, Monday-Saturday

**1-800-827-6655**



When ordering repair parts always give the following information:

- Model Number
- Part Number
- Name of Item
- Part Description





SAVE FOR FUTURE REFERENCE

4637037 / 0-4164588 (12-2-99)

## OWNER'S MANUAL

Model No. 415.154060



**Caution:**  
Read and follow all  
**Safety Statements,**  
**Assembly Instructions,**  
**and Use and Care**  
**Directions** *before*  
attempting to assemble  
and cook.

**Installer / assembler:** Leave  
these instructions with  
consumer.

**To Consumer:** Keep this  
manual for future reference.

 **Some parts may  
contain sharp edges,**  
**especially as noted in the  
manual! Wear protective  
gloves if necessary.**

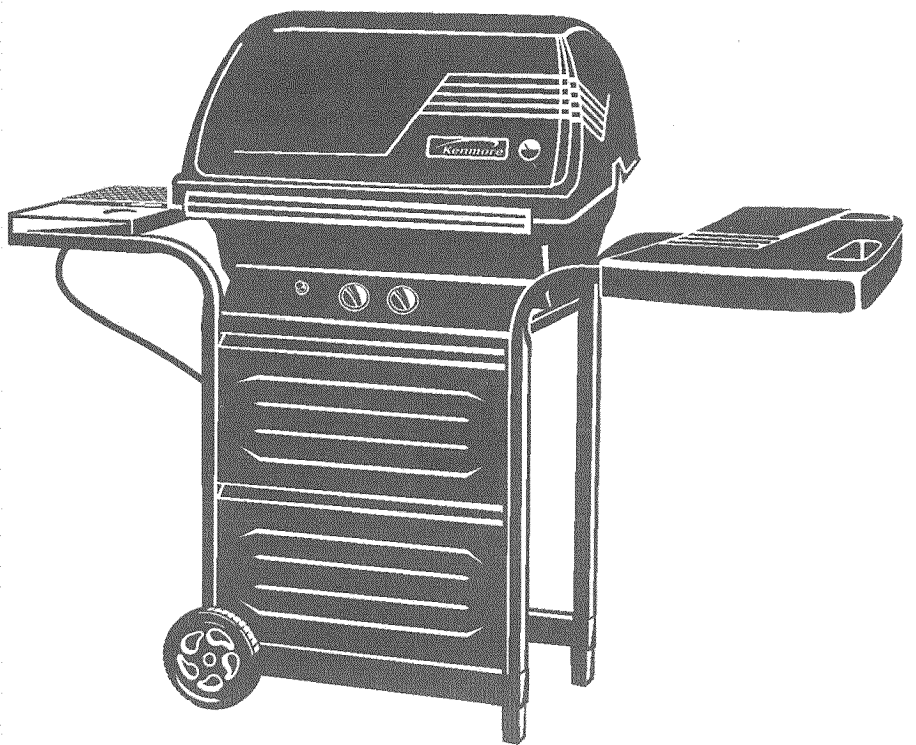

## LP GAS GRILL

- Assembly Instructions
- Parts List  
Parts Diagram

If you have questions or need assistance during assembly, please call 1-800-241-7548. You will be speaking to a representative of the grill manufacturer and not a Sears employee. If you would like to order replacement parts, please contact Sears at 1-800-366-PART as noted on the back of this manual.

**This Grill is for Outdoor Use Only**

**Sears, Roebuck and Co., Hoffman Estates, IL 60179 U.S.A**

Key	Qty	Description	Part #
1	2	Leg Assembly	4502044
2	2	Leg Extender	4156109
3	2	Rail	4503058
4	7	#10-24x1-1/2 Mach Screw	4080303
5	14	#10-24 Hex Nut (keys)	4080208
6	1	Tank Support Bracket	4502040
7	3	#10-24x3/8 Mach Screw	4080379
		STD511003	
8	4	End Cap	4080642
9	2	Wheel	4156956
10	2	5/16 Axle Bolt	4080155
11	4	3/4 Hitch Pin	4156515
12	8	#10x1/2 Self-Tap Screw	4080652
13	2	Fixed Panel	4503880
14	4	Push Fastener	4080675
15	1	Console	4525420
16	1	Valve/Hose/Regulator	4524315
17	1	Grill Bottom	4581968
18	1	Grease Clip	5156607
19	2	1/4-20x1-1/2 Mach Screw	4080324
		STD512515	
20	2	1/4-20 Hex Nut	4080656
21	1	Burner Assembly	4505008
22	1	Briquet Grate	4157101
23	1	Collector Box	4501543
24	1	Electrode	5156119
25	1	#6x3/8 Self-Tap Screw	4080264
26	1	Ignitor Wire	4153720
27	1	Drip VaporISER Bar	4156417
28	1	Side Shelf	4154283
29	5	#10x1-1/2 Screw	4080756
30	1	Grill Lid	4581045
31	2	1/4x1-1/8 Hinge Pin	4156513
32	1	Logo Plate	4156081
33	2	3/16 Pal Nut	4153096
34	1	Heat Indicator w/Bracket	4156800
35	1	Handle	4059000
36	2	#10-24x3-1/2 Mach Screw	4080307
37	2	Handle Spacer	5069502
38	2	Insulated Washer	4080418
39	1	SwingAway	4152124
40	1	Sideburner Body	4525153
41	1	Sideburner Frame	4501705
42	2	#6-32x3/8 Mach Screw	4080361
		STD510603	
43	1	Sideburner Valve Bracket	4501709
44	2	#10-24x3/8 Mach Screw	4080696
45	1	Sideburner Burner	4068076
46	1	Sideburner Ignitor Wire	5156109
47	1	Sideburner Grate	4156376
48	1	Sideburner Knob	4154248
49	1	Ignitor	5156113
50	2	Control Knob	4154203
51	1	Tank Wire	4154195
52	---	Briquets	4159300
53	1	Cooking Grate	4152739

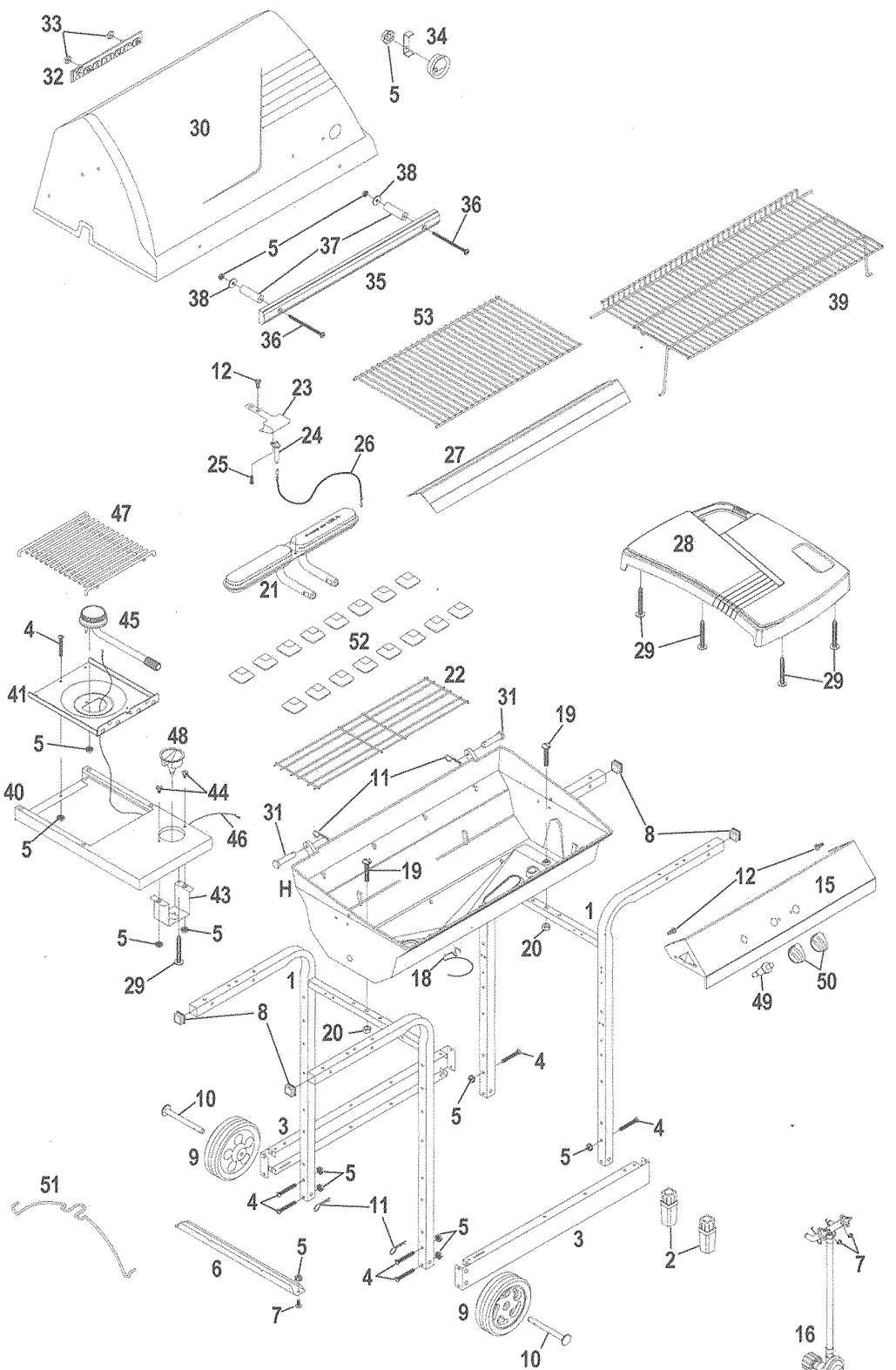

### Before Beginning Assembly

- Necessary tools for assembly of your grill include: screwdrivers (flathead and Phillips®), hammer, pliers and adjustable wrench. A 3/8" and 7/16" nut driver would be ideal.

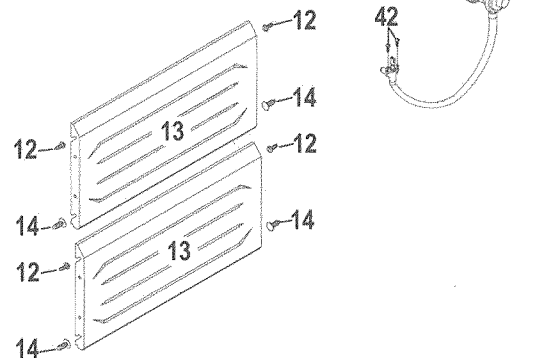
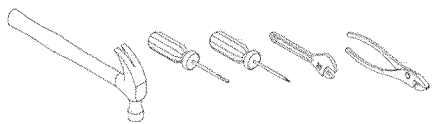

**1**

**NOTE:** Rail with label has the serial and model number for your grill. Write this information on Page 2 of your Use and Care in the "Warranty Information" box.

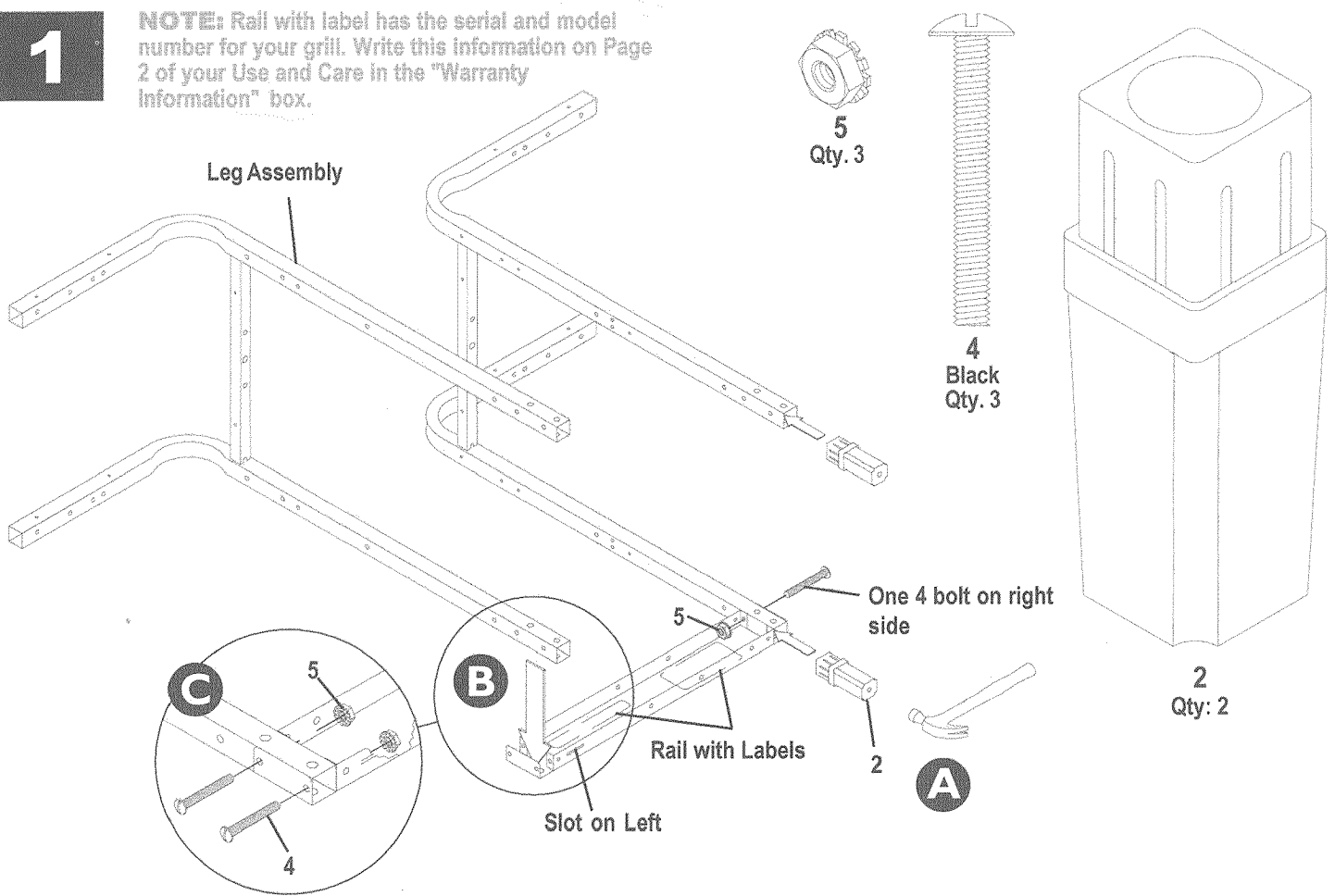

**2**

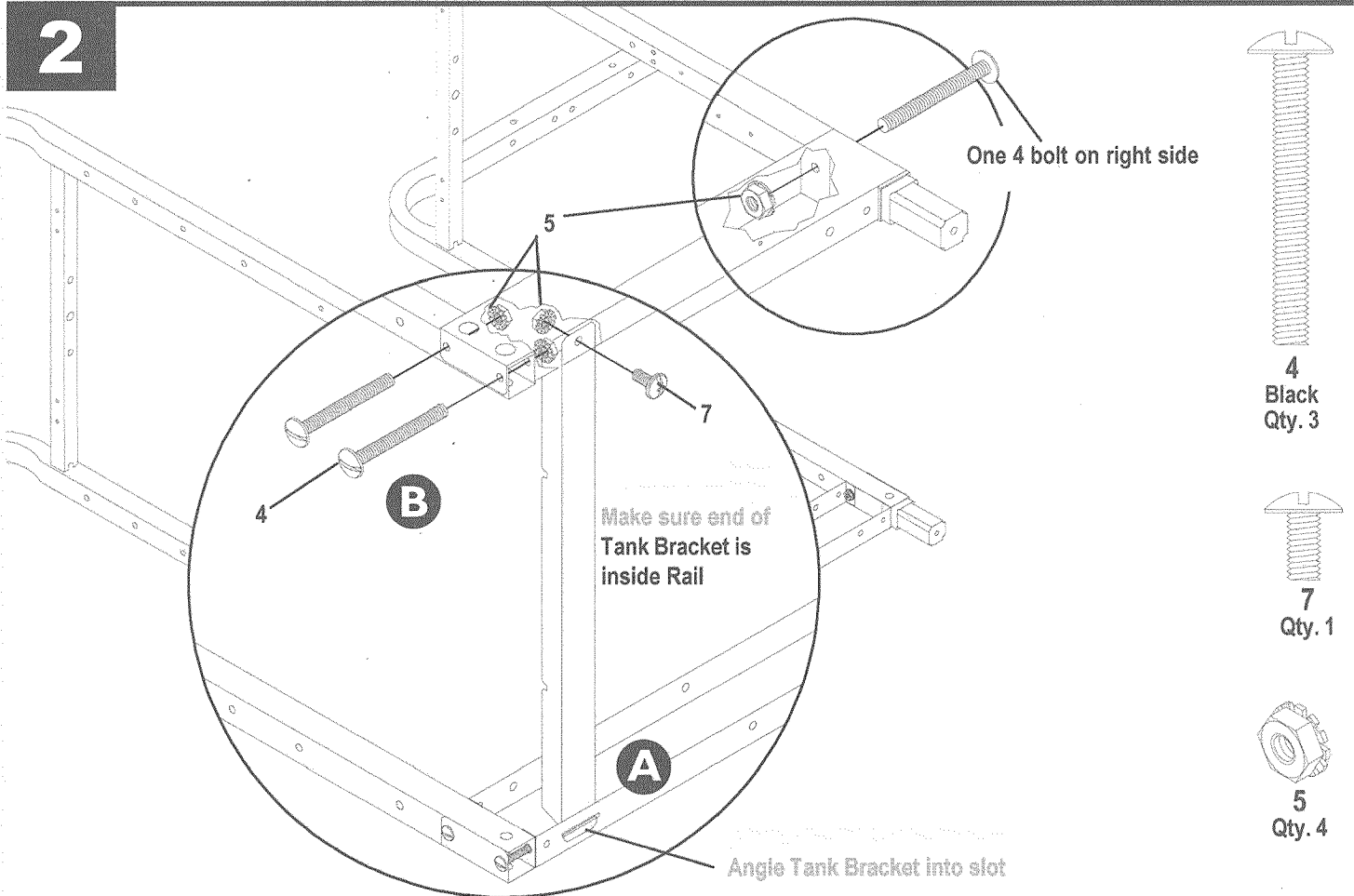

**3**

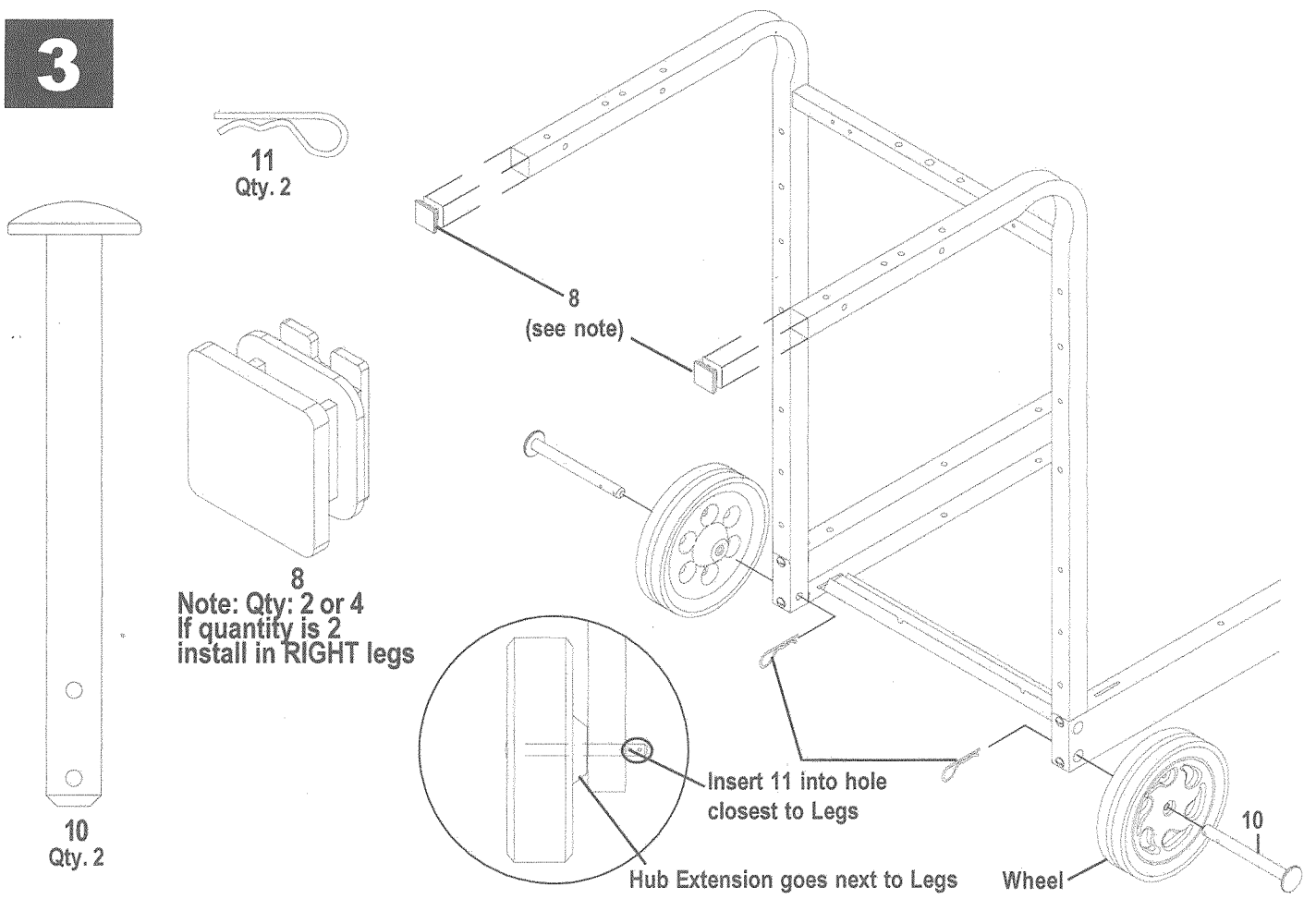

**4**

▲ Fully tighten after Console is attached

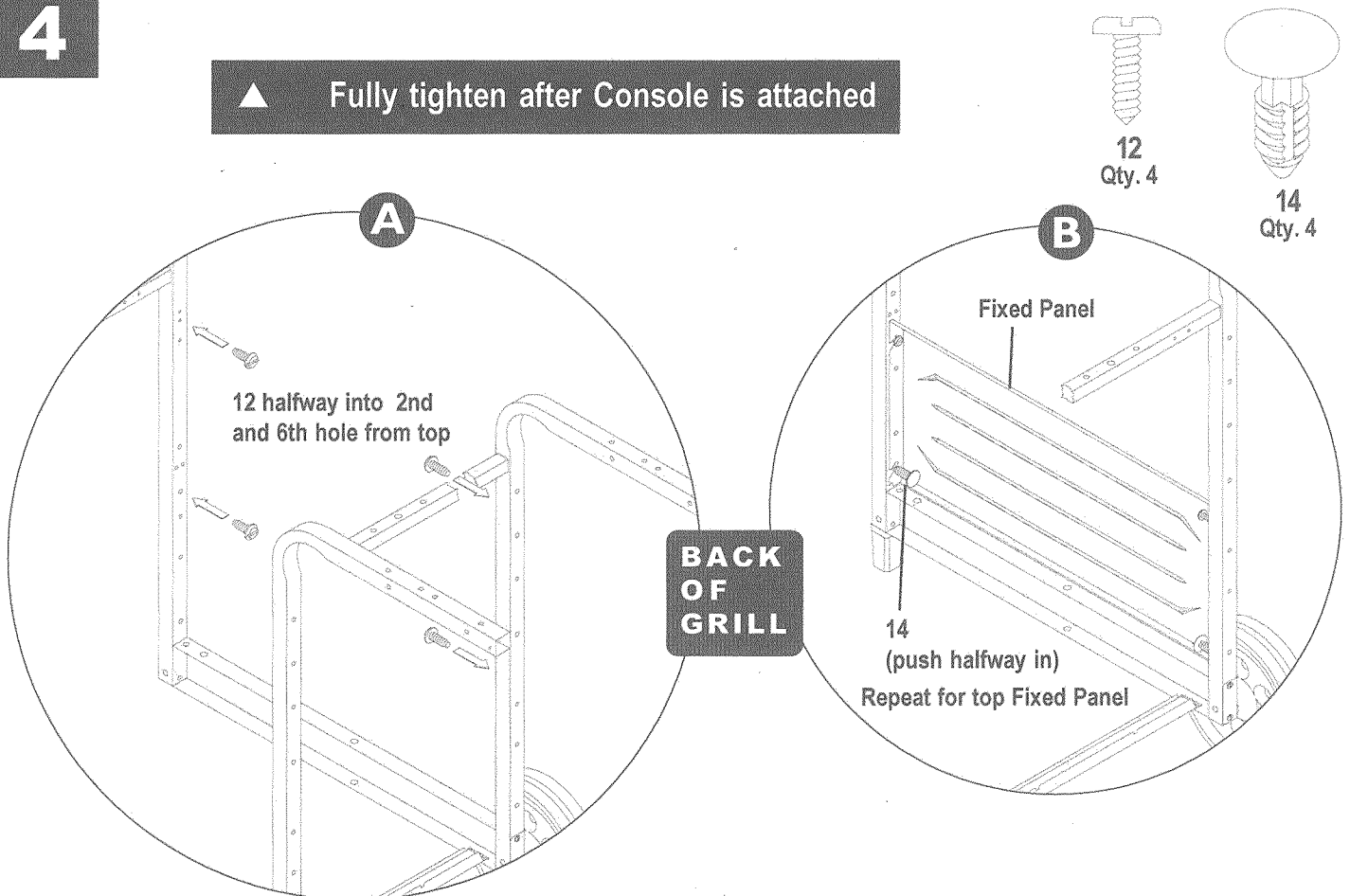

5



▲ Fully tighten screws on the fixed panels.

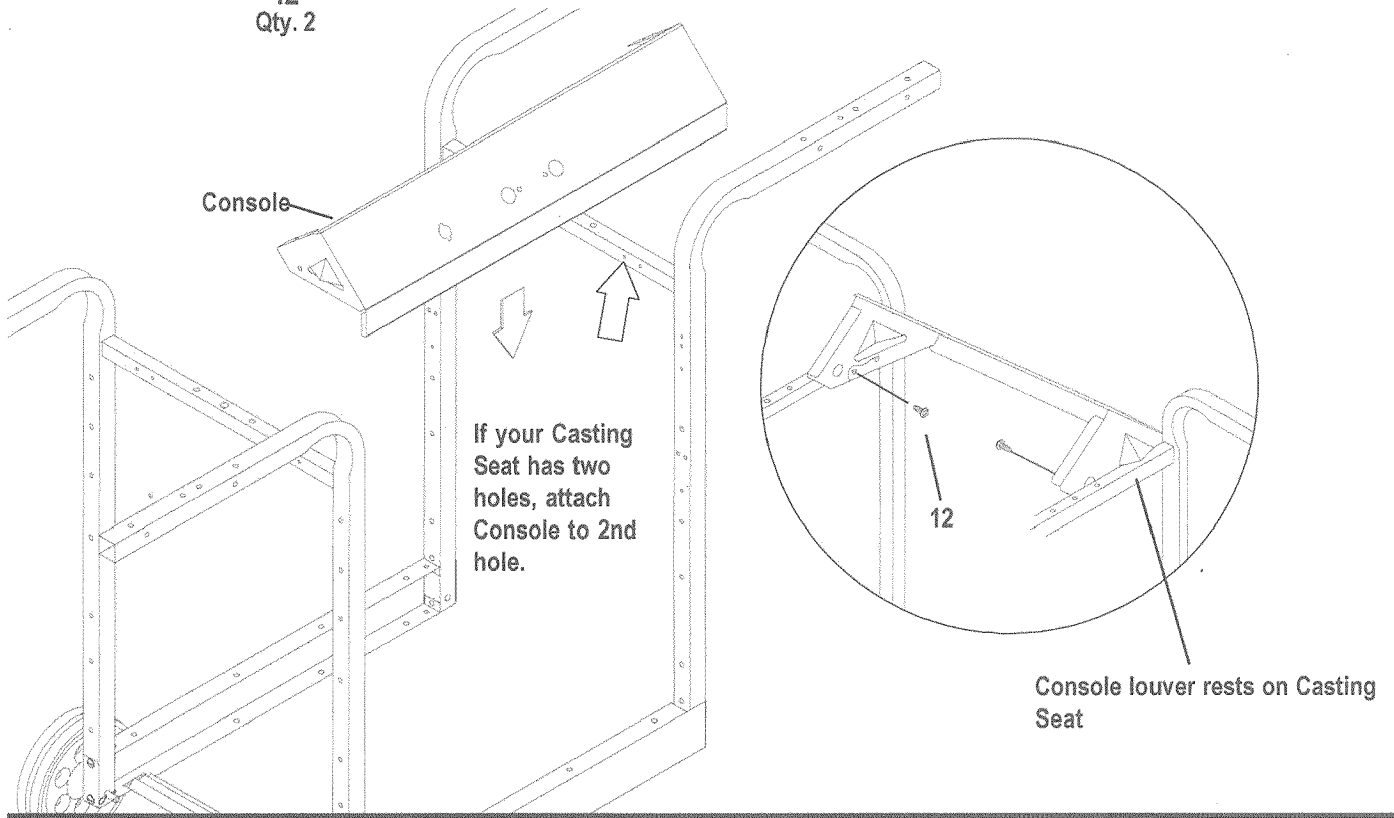

6

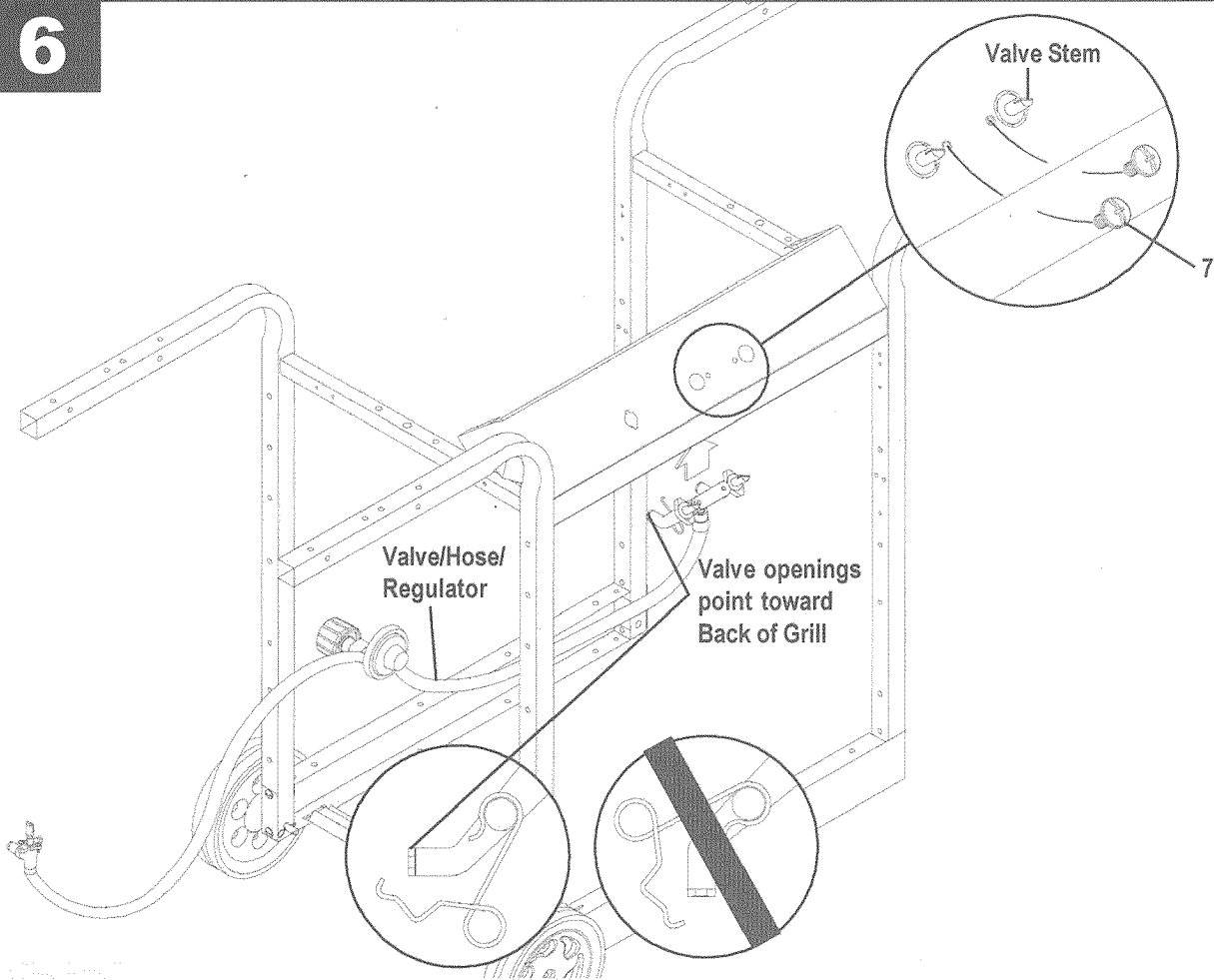
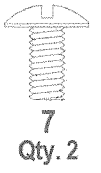

7

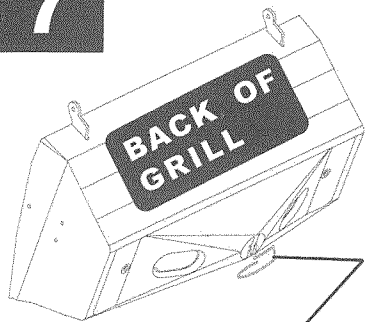

A

▲ Use an empty soup can to hang from the Grease Clip.

### CAUTION

- Failure to install can in clip will cause hot grease to drip from bottom of grill with risk of fire or property damage.

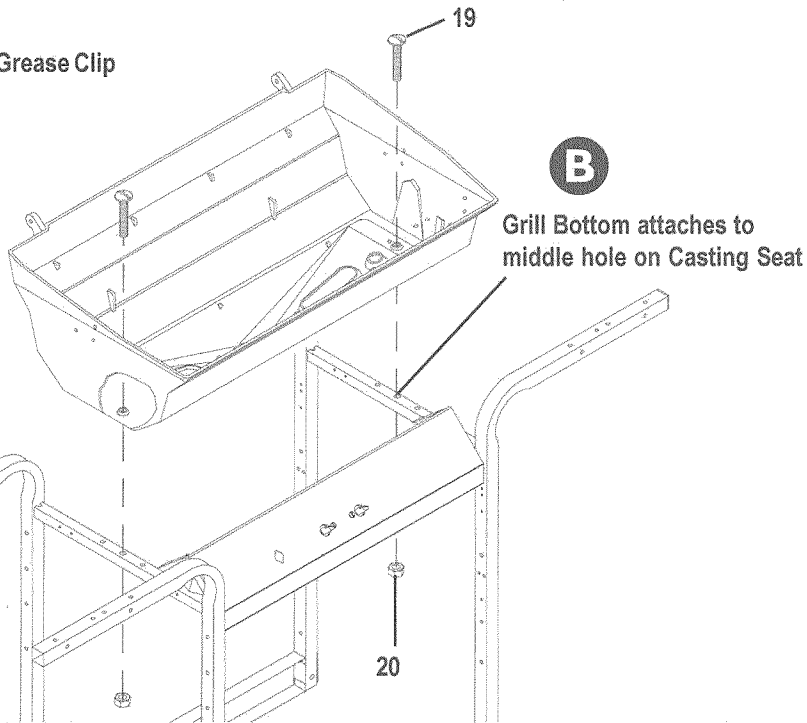

B

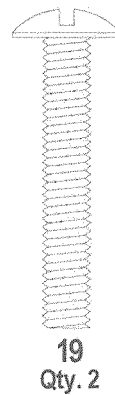

19 Qty. 2



20 Qty. 2

8

▲ VERY IMPORTANT:  
Burner tubes must pass through holes in grill bottom and engage valve attached to console.

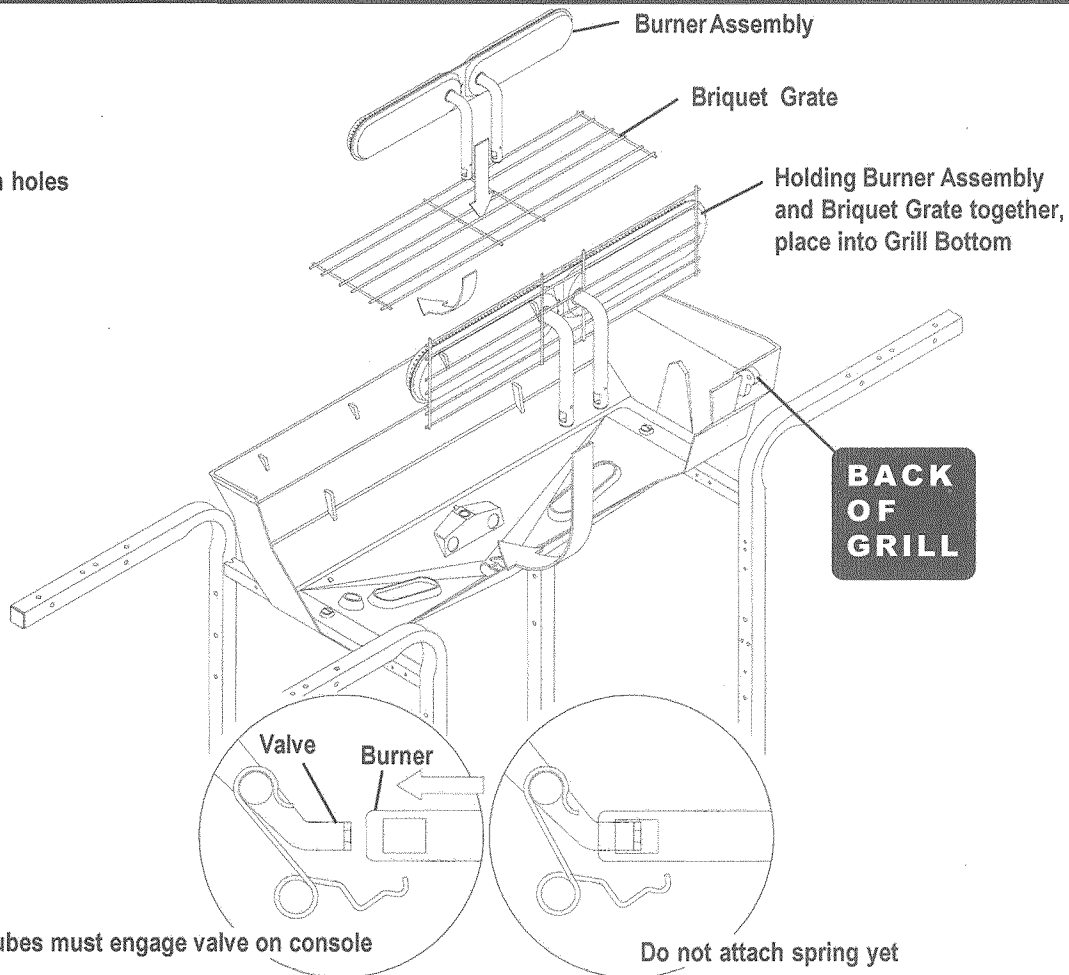

BACK OF GRILL

Burner Tubes must engage valve on console

Do not attach spring yet

# 9

Drip VapoRISER Bar



Attach Electrode to bottom of Collector Box with screw (25)



**A**

In Back Hole of Collector Box attach to Burner Assembly with screw (12)

Lip

**B**  
Attach Ignitor Wire to Electrode and Insert Ignitor Wire into hole in Grill Bottom

Rest

**C**

Round End (to ignitor)

Collector Box

**IMPORTANT**

**D** End of Spring hooks into small hole in bottom of Burner Tubes

Collector Box Lip must be UNDER edge of Burner

▲ The spring keeps burner tubes and valves engaged and must be attached correctly.

# 10

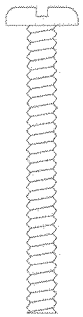

29  
Silver  
Qty. 4

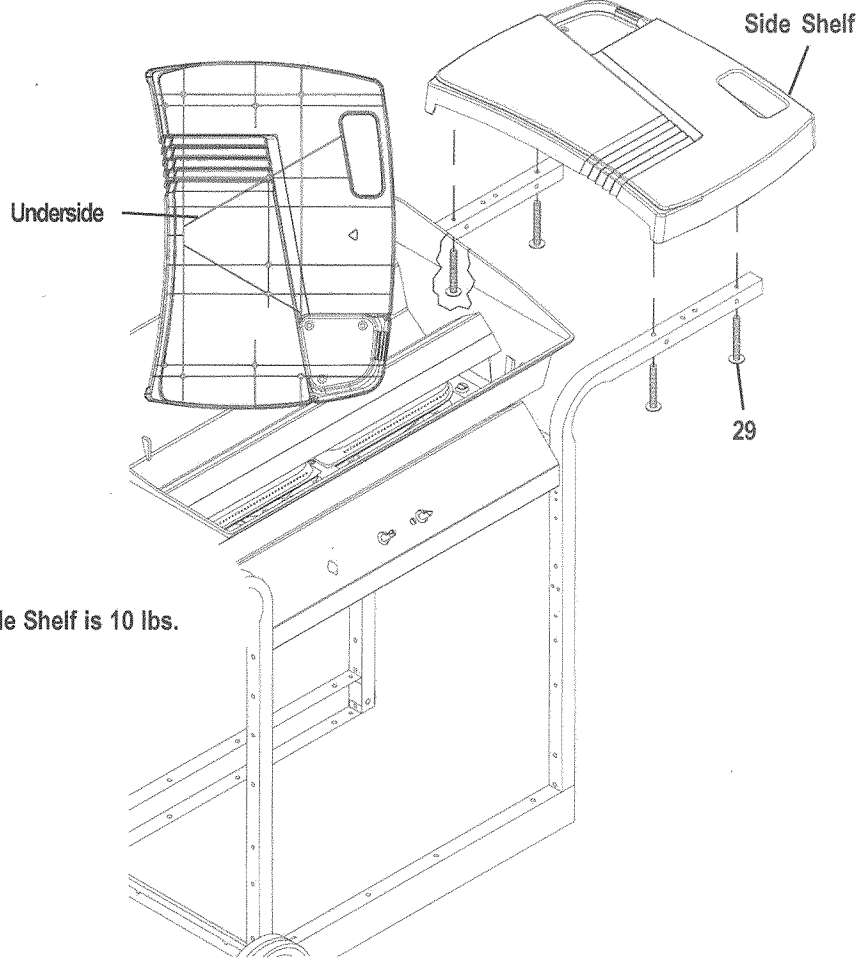

▲ Maximum load for Side Shelf is 10 lbs.

# 11

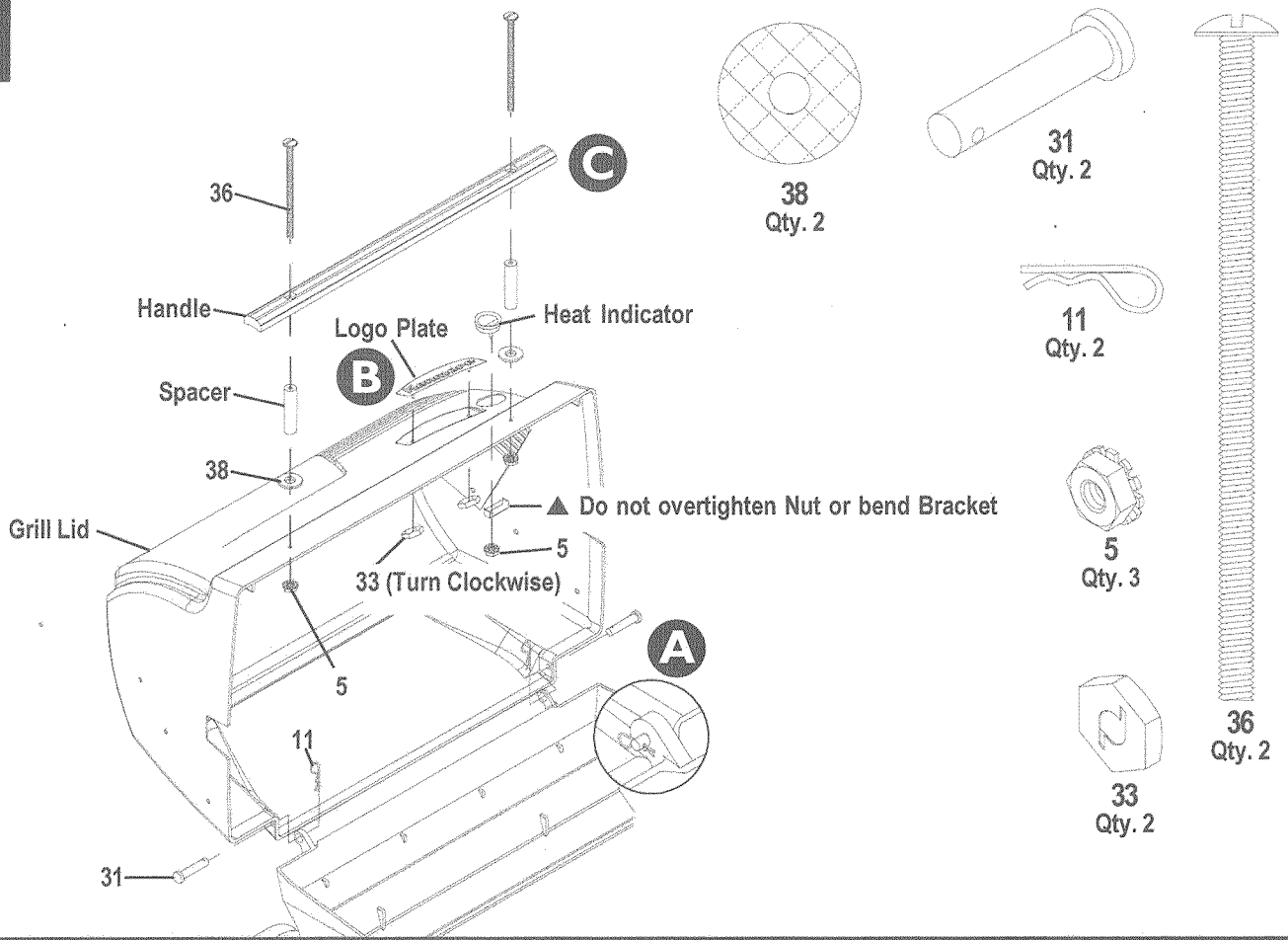

# 12

- ▲ SwingAway will keep food warm, while keeping it away from flames. Do not use SwingAway for cooking meats or heavy food items.
- ▲ Pivot and leg wires must run underneath SwingAway surface.

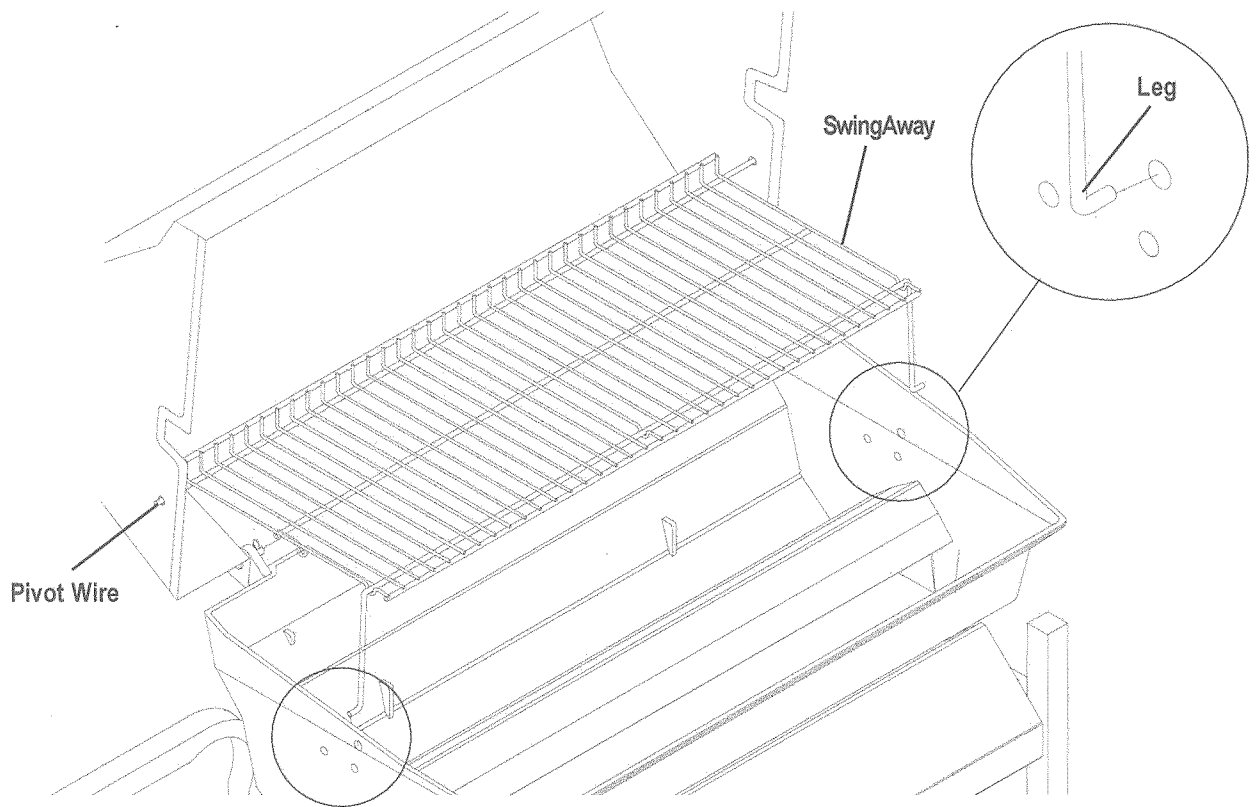



# 13

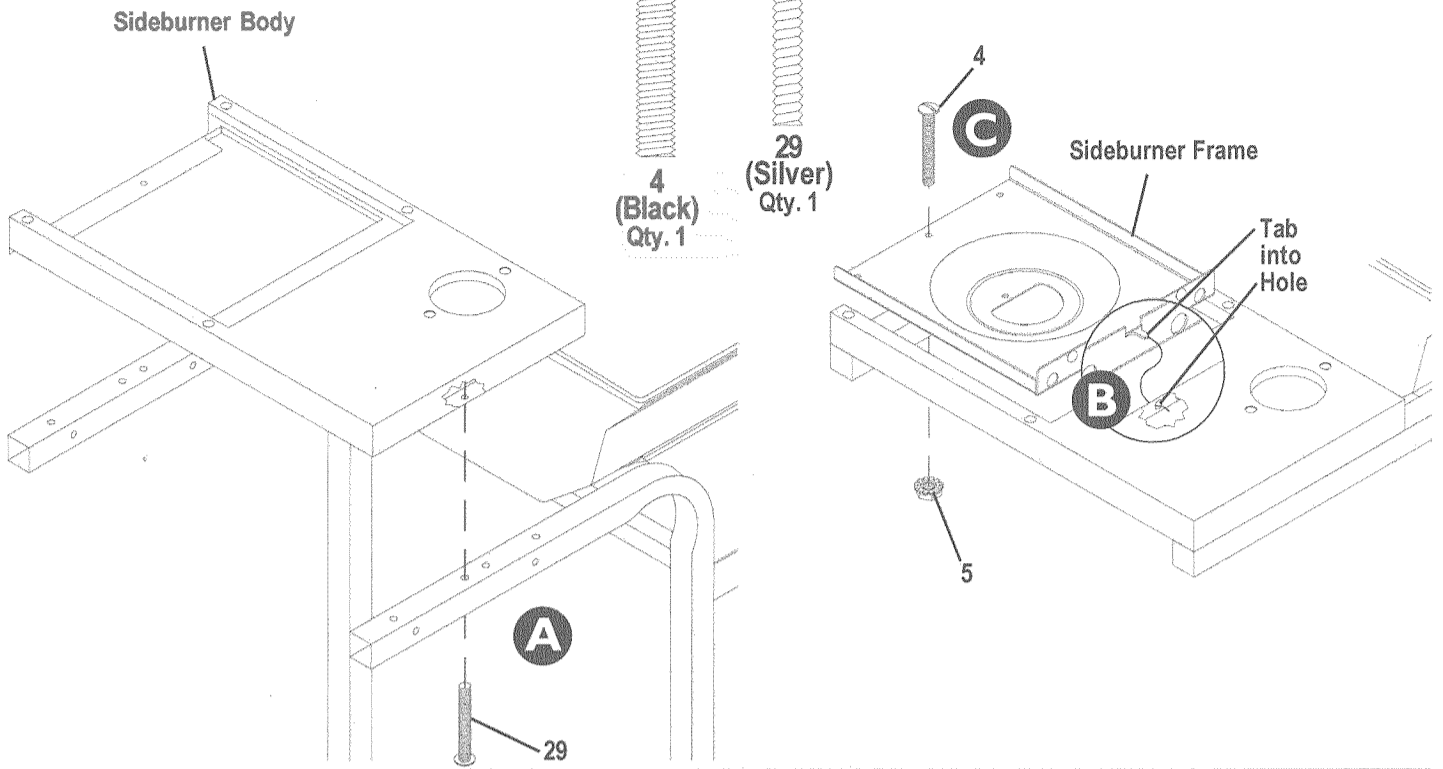
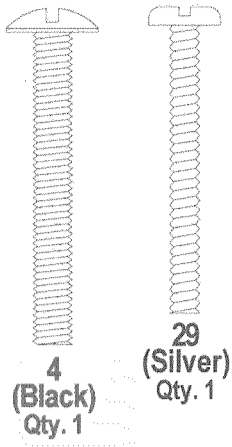

# 14

Thread 42 halfway into sideburner valve, place in right slot of valve bracket

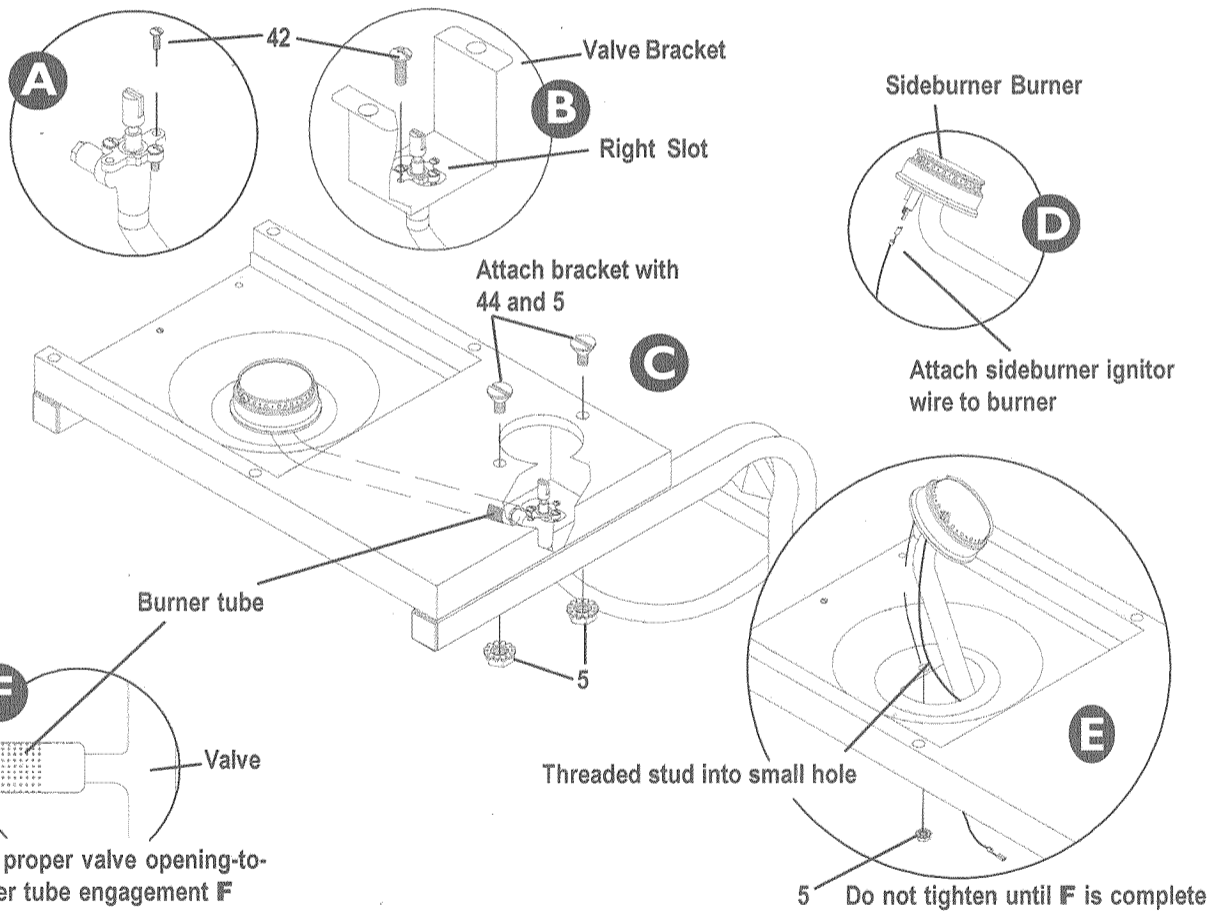

# 15

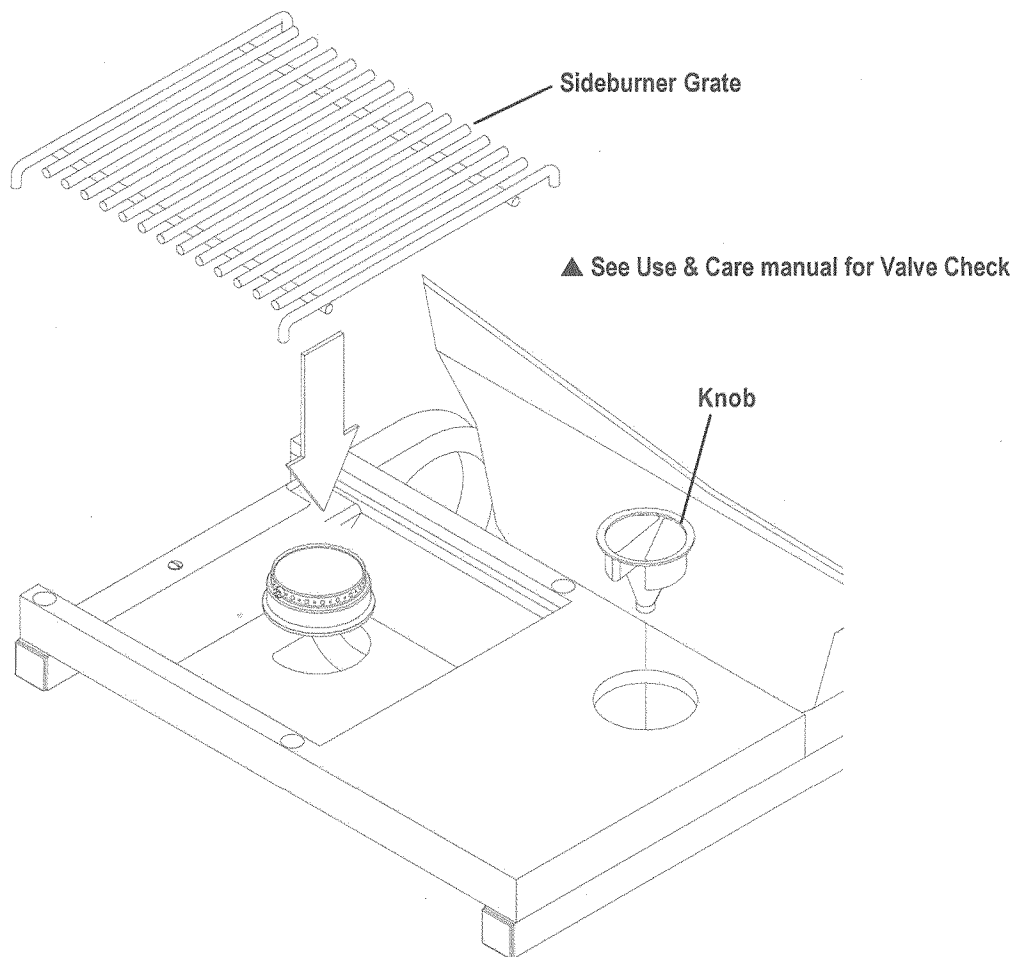

# 16

- ▲ When installing Ignitor do not push on button. This may cause a minor shock.
- ▲ Sideburner electrode wire must be connected to Ignitor for grill and Sideburner to ignite.
- ▲ Ignitor Wire(s) must not come into contact with grill bottom.
- ▲ See Use and Care for Valve Check.

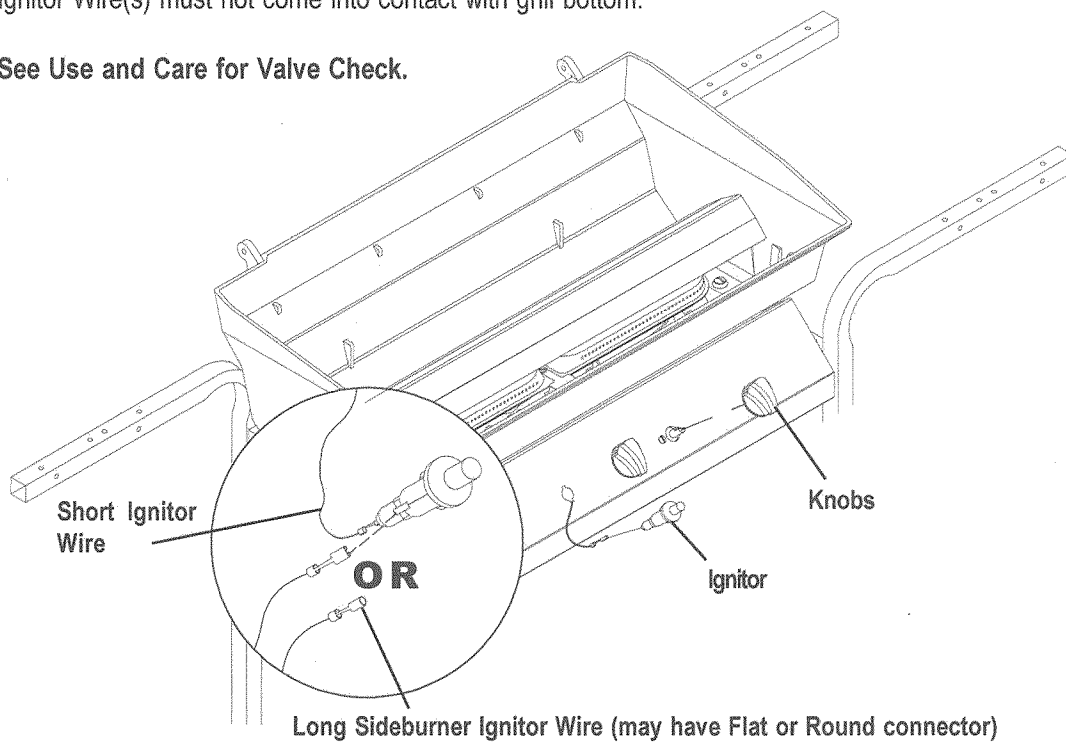

# 17

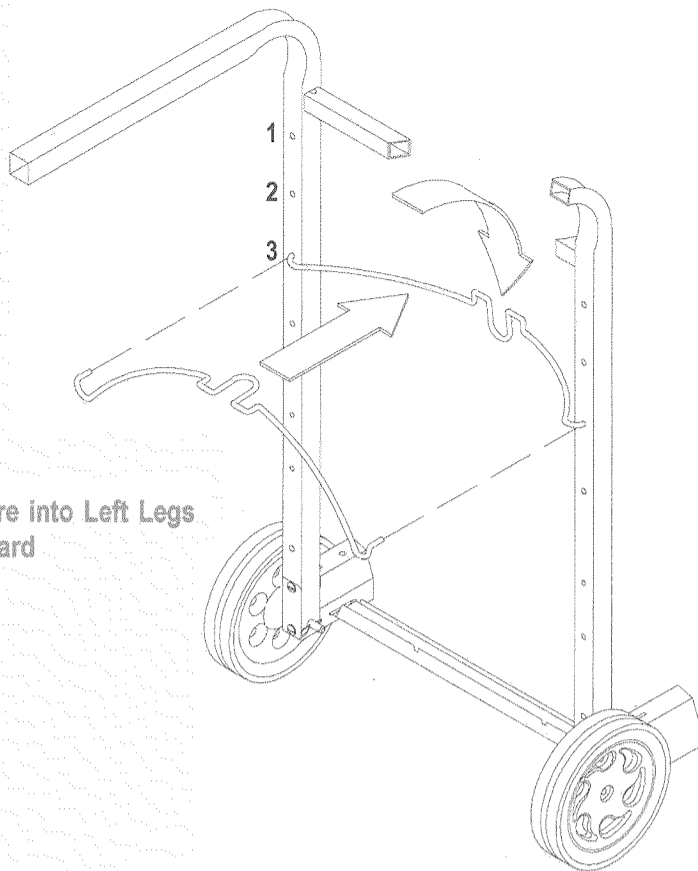

Insert Tank Wire into Left Legs and rotate inward

# 18

▲ LP tank is sold separately. Fill before attaching to grill.

▲ Curved portion of tank wire should be to inside of tank collar.

▲ For filling of tank and connection of tank to regulator, see the Use and Care Manual.

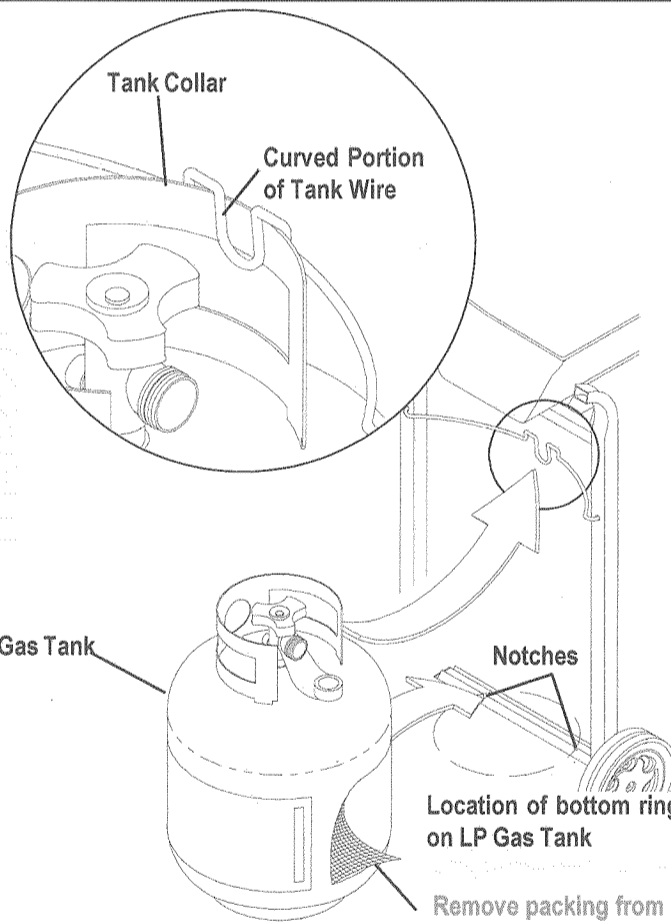

## CAUTION

- Tank collar opening must face to front of cart once tank is attached.
- Failure to install tank correctly may allow gas hose to be damaged in operation.

See Use and Care Manual for important safety instructions before using.

# 19

Perform the "Burner Flame Check" in the Use and Care section.

▲ Let grill cool before placing briquets.

Place 16 briquets. Do not layer or stack just enough to cover fire grate surface.

▲ Do not let briquets cover burner port holes

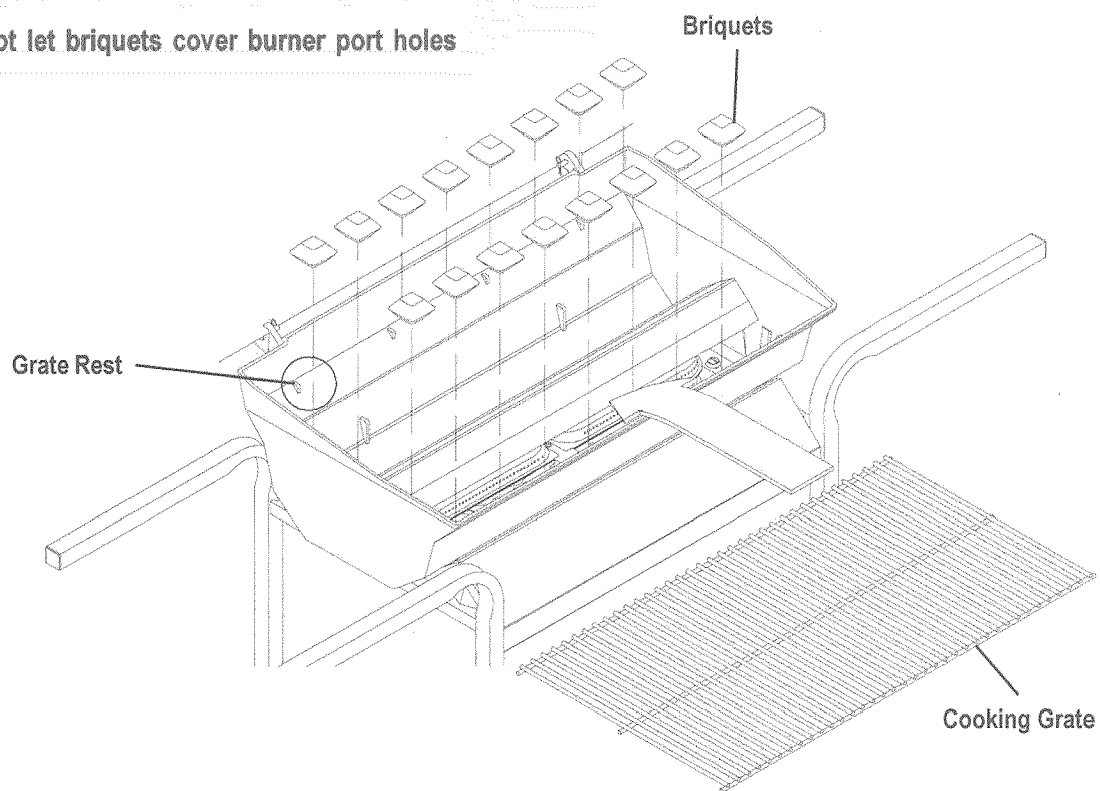



# Recipes

---

## Char-Broil Turkey

Yield: 14 to 16 generous servings or 1 lb. per person

Cooking time: 25 minutes per pound • Method: Grill on low

12 to 14 lb. turkey, thawed completely	vegetable oil
1 large apple, quartered	1 quart water
1-1/2 sticks butter	2 stalks celery, cut in 2" pieces
1 orange, quartered	2 onions, cut in large cubes
1 lemon, thinly sliced or 4 tbs. lemon juice	salt and pepper
cheesecloth (optional)	

Heat grill to medium. Wash and rinse turkey, removing giblets. Dry with absorbent paper. Bend wings back behind turkey. Season inside of turkey with salt and pepper. Rub outside of bird with oil. Stuff with onions, celery, orange and apple. Completely fill cavity (this gives moisture to the turkey). Cover openings of turkey with excess skin. Melt butter in a large aluminum foil pan. Add turkey, water and lemon juice. Place on grill and turn heat to low. Baste with butter, cover top with cheesecloth and baste again. Baste every 1/2 hour until done. Serve with **Giblet Gravy**.

## Giblet Gravy

2 to 3 turkey or chicken giblets	salt and pepper to taste
3-4 tbs. turkey or chicken fat	1/4 tsp. Accent
1/4 cup flour	dash of thyme
2 cups fat-free pan juices	1/8 tsp. Kitchen Bouquet
2 hard boiled eggs, finely chopped	milk, if needed
giblet broth, if needed	

Boil giblets until tender, reserving broth. Chop giblets and set aside. Remove grilled turkey from baking pan and place on hot platter. Pour all pan juices into large measuring cup. Skim off fat, reserving 3 to 4 tbs. Place reserved fat into a deep saucepan, heating over moderate heat. Stir in flour, whisking well with wire whisk. Cook over low heat until bubbly then remove from heat. Add fat-free pan juices (add milk and giblet broth to juices to make 2 full cups). Blend well with wire whisk. Season with salt, pepper, Accent, thyme and Kitchen Bouquet, whisking continuously. Return mixture to heat and continue stirring for 3 to 4 minutes. Add chopped eggs.

## Smoked Turkey Breast

Cooking time: 25 minutes Per Pound • Method: Grill Indirect Heat

1 turkey breast, fresh or thawed	1 large bottle Italian dressing
1 large plastic roasting bag	1 small bottle soy sauce

Mix dressing and soy sauce. Place turkey breast in bag and pour mixture over turkey breast. Marinate in refrigerator overnight. Light one side of grill with setting on low. Remove turkey from marinade and reserve liquid. Put meat thermometer in turkey breast being certain not to touch bone. Place turkey on the grill away from direct heat. Grill over low fire, basting and rotating often. Remove when meat thermometer registers 180°F.

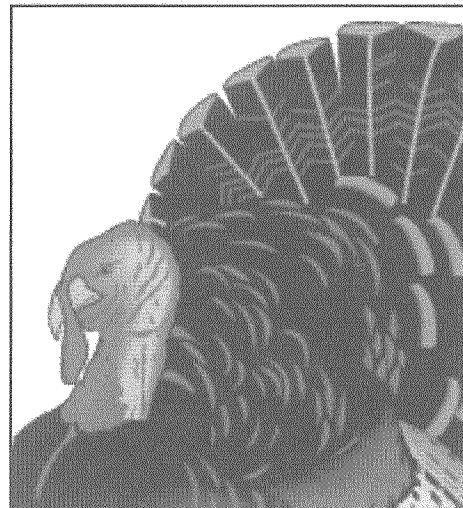



# Recipes

---

## Savory Sirloin Steak

Yield: 4-6 Servings • Cooking Time: 15-25 Minutes • Method: Medium-Hot

1/4 cup Worcestershire sauce	1 (3 lb.) sirloin steak
1 tbs. minced onion	2 tbs. steak sauce
2 tbs. lemon juice	2 tbs. butter, melted
2 tbs. oil	1 tbs. chopped parsley
1 tsp. salt	1 tsp. Worcestershire
1/2 tsp. instant minced garlic	

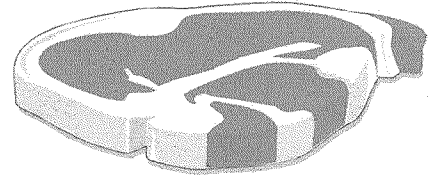

Combine first 6 ingredients. Pour into a heavy plastic bag and add steak. Marinate in refrigerator 4 hours or overnight, turning occasionally. Remove steaks from marinade about 1 hour before grilling. Drain. Place on grill over hot fire. Grill about 8 to 12 minutes on each side, or to desired degree of doneness. Combine remaining ingredients and spoon over steak before serving. Slice steak in thin diagonal slices.

## Teriyaki Steak

Yield: 6-8 Servings • Cooking Time: 30 Minutes • Method: Medium-Hot

1 2 lb. flank steak	1 tsp. ginger	1/4 cup water
1 clove garlic, minced	2 tbs. sugar	2 tsp. meat tenderizer
1/3 cup grated onion	1/2 cup soy sauce	1 tsp. Liquid Smoke

Score steak in diamond pattern on both sides. Place steak in heavy plastic bag. Combine marinade ingredients and pour over steaks. Marinate at room temperature 2 to 3 hours, or in refrigerator overnight, turning occasionally. Allow steak to come to room temperature before grilling. Reserve marinade. Place on grill over medium-hot fire and grill with lid down for 15 minutes, basting often. Turn and grill another 15 minutes or until done to your liking. Continue basting.

## Eye of Round

Yield: 6 Servings • Cooking Time: About 1-1/4 Hours • Method: Low-Medium

1 (3 lb.) eye of round	1/3 cup wine vinegar
2/3 cup Worcestershire sauce	2/3 cup salad oil
1/3 cup soy sauce	

Marinate roast overnight in above mixture. Cook over low fire until done. Check after 1 hour for medium rare. Slice very thin and serve with **Horseradish Sauce**.

## Horseradish Sauce

Yields: 1-1/2 cups

Combine all ingredients in blender.	1 (3 oz.) pkg. cream cheese	2 tbs. horseradish	1 cup sour cream
1/4 tsp. each : sugar, salt and pepper	1 tsp. grated onion		



# Recipes

---

## Indirect Cooking:

You can bake or slowly roast many foods on a covered grill by cooking indirectly. Simply light the gas on one side of the grill and place the food on the other side. Close the lid and your grill will bake or roast like a conventional oven.

## Lemon Herb Chicken

Yield: 6 Servings • Cooking Time: 45 Minutes • Method: Low

1/2 cup fresh lemon juice	Grated rind of 1 lemon
1-1/2 tsp. crushed sweet basil	1/2 tsp. crushed thyme
2 cloves garlic, crushed	2 tsp. salt
1 tsp. paprika	1 cup oil
1-1/2 tsp. onion powder	1 cut up frying chicken

Combine all ingredients and pour into plastic bag. Add chicken and marinate for 6 to 8 hours in refrigerator, turning occasionally. Remove from refrigerator 1 hour before grilling. Place chicken on grill, skin-side up. Cook for 20 to 25 minutes, basting often with marinade. Turn, cook for 20 minutes longer. Serve immediately.

## Polynesian Chicken

Yield: 4 Servings • Cooking Time • 1 to 1-1/2 Hours • Method: Low

2 (2 Lb.) split broilers	2 tsp. salt
1/2 cup oil	1/2 tsp. pepper

Brush chicken with oil and season with salt and pepper. Place on grill with bone side down. Grill slowly. Turn after 20 to 25 minutes and cook about 20 minutes longer. Meanwhile make the below listed glaze.

## Pineapple Glaze

1 cup crushed pineapple, drained and reserve 1/4 cup syrup	2 tbs. prepared mustard
2 tbs. lemon juice	1/2 tsp. salt
	1 cup brown sugar

Combine ingredients, brush both sides of chicken with glaze and broil about 10 minutes more or until tender. Turn and baste with glaze. Serve extra glaze with chicken.

## Chicken Shish Kabobs

Yield: 4 Servings • Cooking Time: 12-16 Minutes • Method: Medium

4 chicken breast halves, boned and cut into 1-1/2 inch pieces	1 cup soy sauce
1 green pepper, cut in 1 inch pieces	1/2 lb. mushrooms
1 zucchini squash sliced and parboiled	1 small can pineapple chunks, juice reserved

Combine all but pineapple chunks (include the pineapple juice). Marinate for 8 to 12 hours in refrigerator. Thread chicken, pineapple, mushrooms and bell pepper alternately on skewers. Grill over medium fire for 6 to 8 minutes on each side or until done.

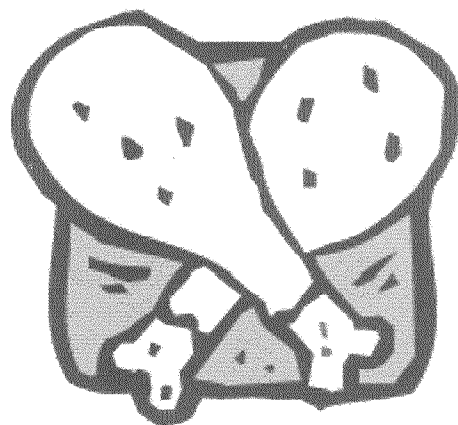

**For the repair or replacement parts you need delivered directly to your home**

Call 7 am - 7 pm, 7 days a week

**1-800-366-PART**

(1-800-366-7278)

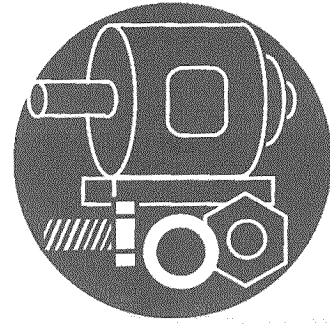

**For in-home major brand repair service**

Call 24 hours a day, 7 days a week

**1-800-4-REPAIR**

(1-800-473-7247)

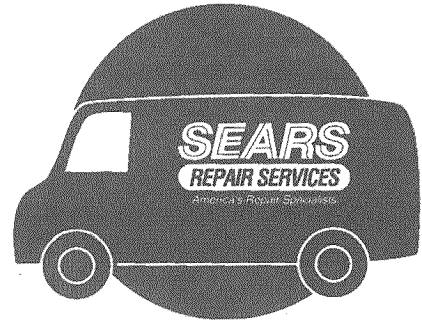

**For the location of a Sears Parts and Repair Center in your area**

Call 24 hours a day, 7 days a week

**1-800-488-1222**

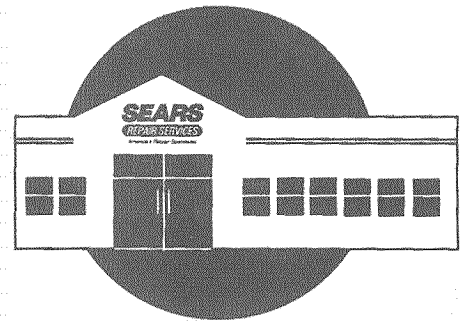

**For information on purchasing a Sears Maintenance Agreement or to inquire about an existing Agreement**

Call 9 am - 5 pm, Monday-Saturday

**1-800-827-6655**



When ordering repair parts always give the following information:

- Model Number
- Part Number
- Name of Item
- Part Description





SAVE FOR FUTURE REFERENCE

4637037 / 0-4164588 (12-2-99)

## OWNER'S MANUAL

Model No. 415.154060



**Caution:**  
Read and follow all  
**Safety Statements,**  
**Assembly Instructions,**  
**and Use and Care**  
**Directions** *before*  
attempting to assemble  
and cook.

**Installer / assembler:** Leave  
these instructions with  
consumer.

**To Consumer:** Keep this  
manual for future reference.

 **Some parts may  
contain sharp edges,**  
**especially as noted in the**  
**manual! Wear protective**  
**gloves if necessary.**

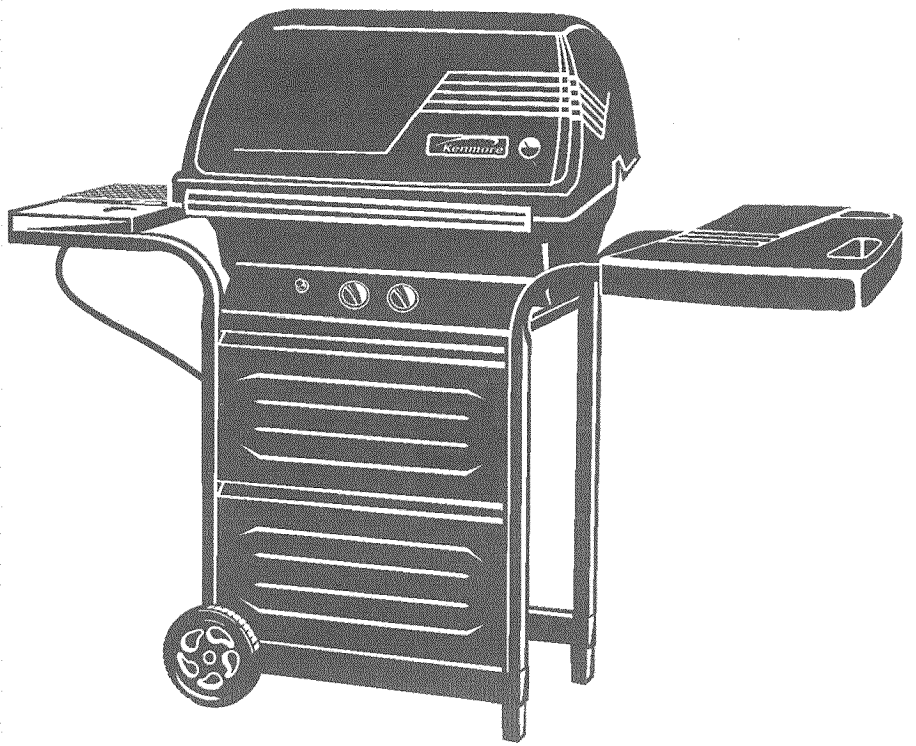

## LP GAS GRILL

- Assembly Instructions
- Parts List  
Parts Diagram

If you have questions or need assistance during assembly, please call 1-800-241-7548. You will be speaking to a representative of the grill manufacturer and not a Sears employee. If you would like to order replacement parts, please contact Sears at 1-800-366-PART as noted on the back of this manual.

**This Grill is for Outdoor Use Only**

---

Sears, Roebuck and Co., Hoffman Estates, IL 60179 U.S.A

---

Key	Qty	Description	Part #
1	2	Leg Assembly	4502044
2	2	Leg Extender	4156109
3	2	Rail	4503058
4	7	#10-24x1-1/2 Mach Screw	4080303
5	14	#10-24 Hex Nut (keys)	4080208
6	1	Tank Support Bracket	4502040
7	3	#10-24x3/8 Mach Screw	4080379
		STD511003	
8	4	End Cap	4080642
9	2	Wheel	4156956
10	2	5/16 Axle Bolt	4080155
11	4	3/4 Hitch Pin	4156515
12	8	#10x1/2 Self-Tap Screw	4080652
13	2	Fixed Panel	4503880
14	4	Push Fastener	4080675
15	1	Console	4525420
16	1	Valve/Hose/Regulator	4524315
17	1	Grill Bottom	4581968
18	1	Grease Clip	5156607
19	2	1/4-20x1-1/2 Mach Screw	4080324
		STD512515	
20	2	1/4-20 Hex Nut	4080656
21	1	Burner Assembly	4505008
22	1	Briquet Grate	4157101
23	1	Collector Box	4501543
24	1	Electrode	5156119
25	1	#6x3/8 Self-Tap Screw	4080264
26	1	Ignitor Wire	4153720
27	1	Drip VaporISER Bar	4156417
28	1	Side Shelf	4154283
29	5	#10x1-1/2 Screw	4080756
30	1	Grill Lid	4581045
31	2	1/4x1-1/8 Hinge Pin	4156513
32	1	Logo Plate	4156081
33	2	3/16 Pal Nut	4153096
34	1	Heat Indicator w/Bracket	4156800
35	1	Handle	4059000
36	2	#10-24x3-1/2 Mach Screw	4080307
37	2	Handle Spacer	5069502
38	2	Insulated Washer	4080418
39	1	SwingAway	4152124
40	1	Sideburner Body	4525153
41	1	Sideburner Frame	4501705
42	2	#6-32x3/8 Mach Screw	4080361
		STD510603	
43	1	Sideburner Valve Bracket	4501709
44	2	#10-24x3/8 Mach Screw	4080696
45	1	Sideburner Burner	4068076
46	1	Sideburner Ignitor Wire	5156109
47	1	Sideburner Grate	4156376
48	1	Sideburner Knob	4154248
49	1	Ignitor	5156113
50	2	Control Knob	4154203
51	1	Tank Wire	4154195
52	---	Briquets	4159300
53	1	Cooking Grate	4152739

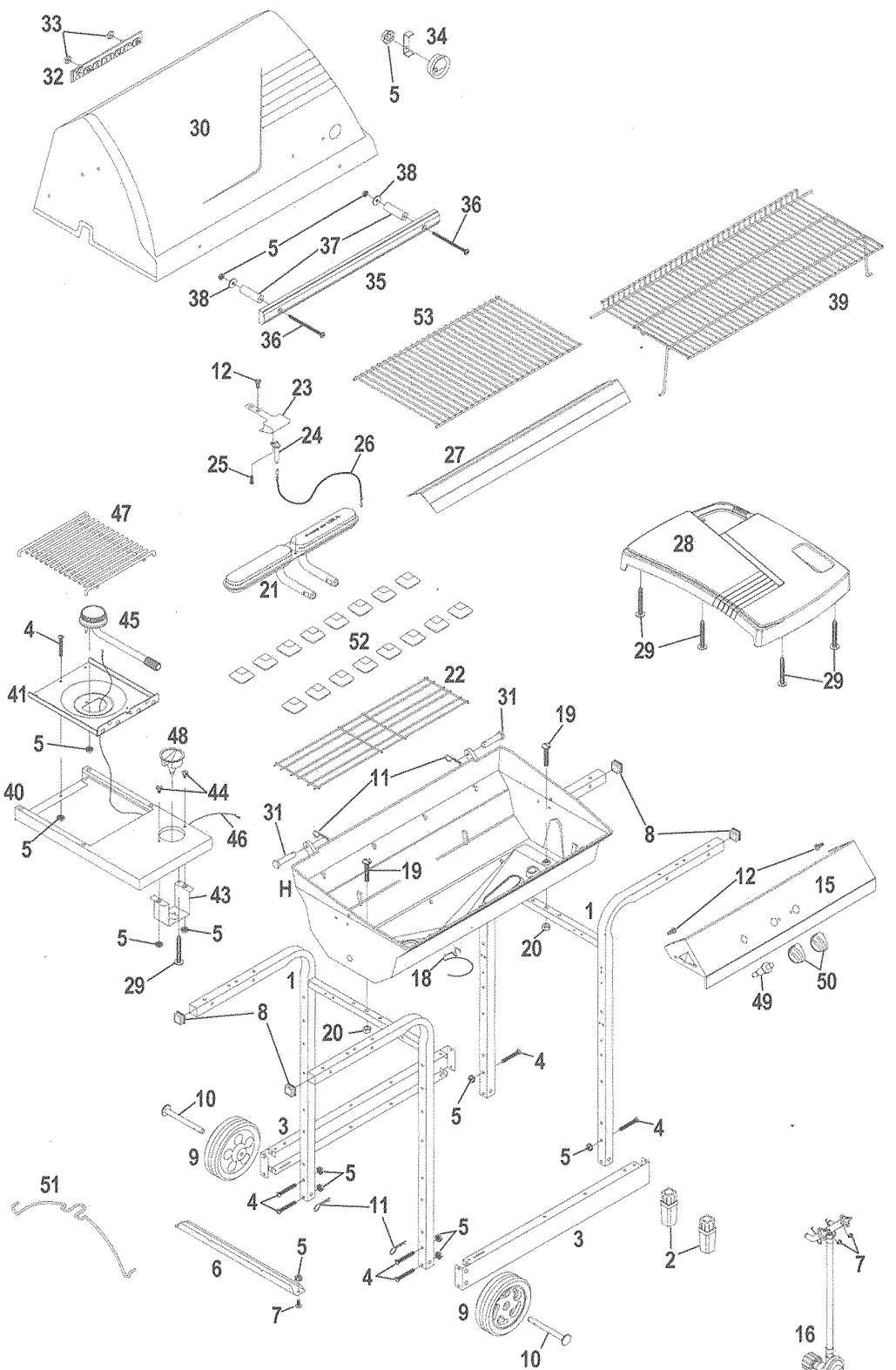

### Before Beginning Assembly

- Necessary tools for assembly of your grill include: screwdrivers (flathead and Phillips®), hammer, pliers and adjustable wrench. A 3/8" and 7/16" nut driver would be ideal.

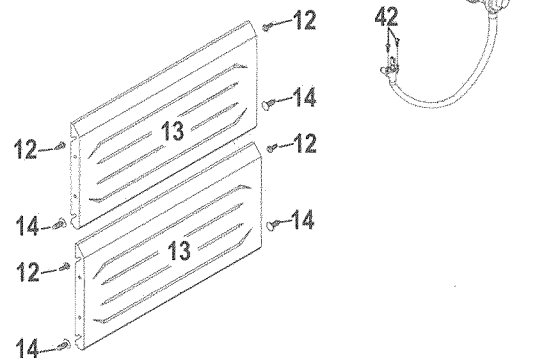
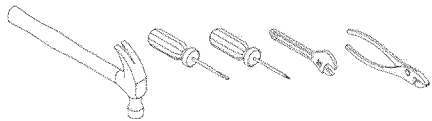

**1**

**NOTE:** Rail with label has the serial and model number for your grill. Write this information on Page 2 of your Use and Care in the "Warranty Information" box.

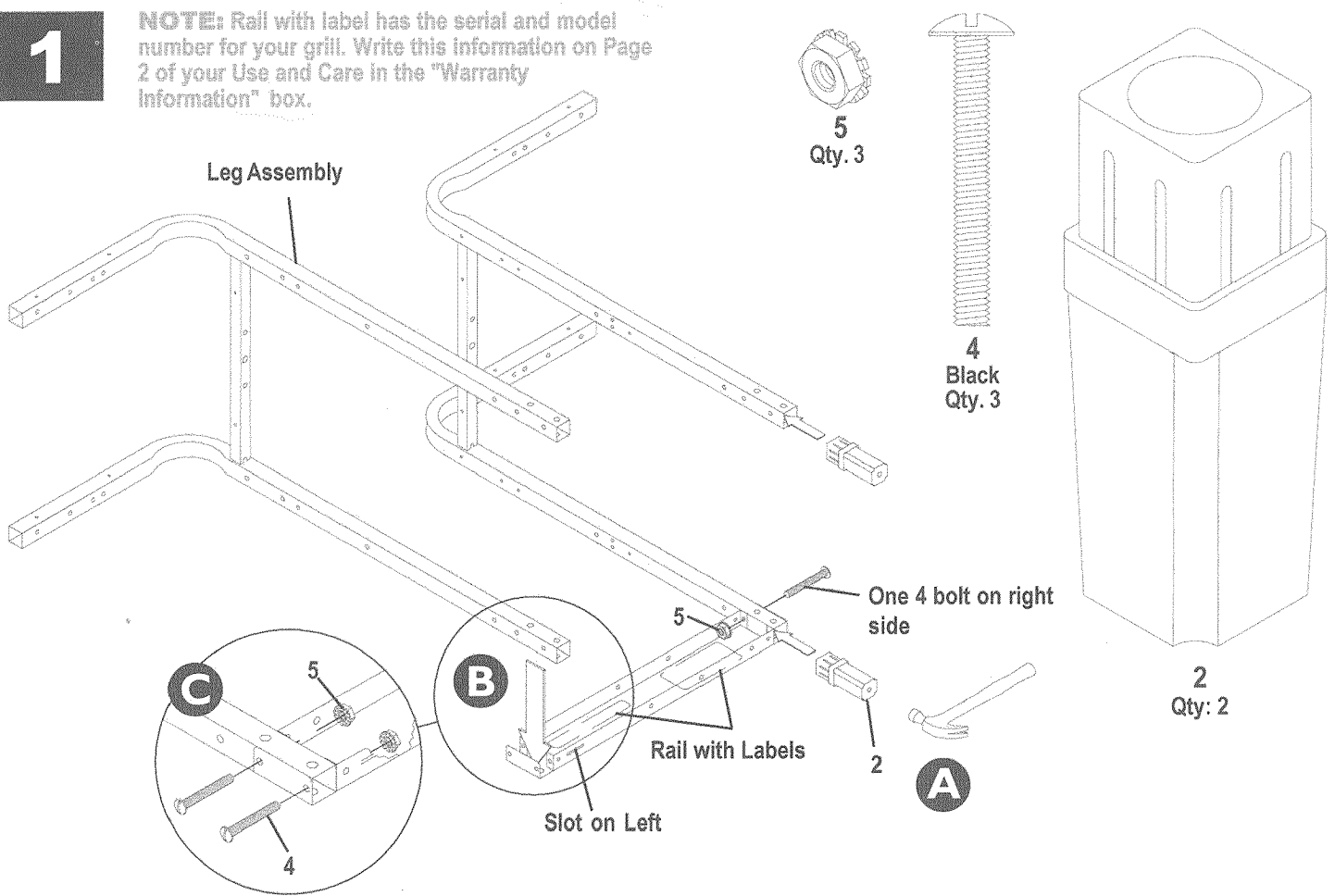

**2**

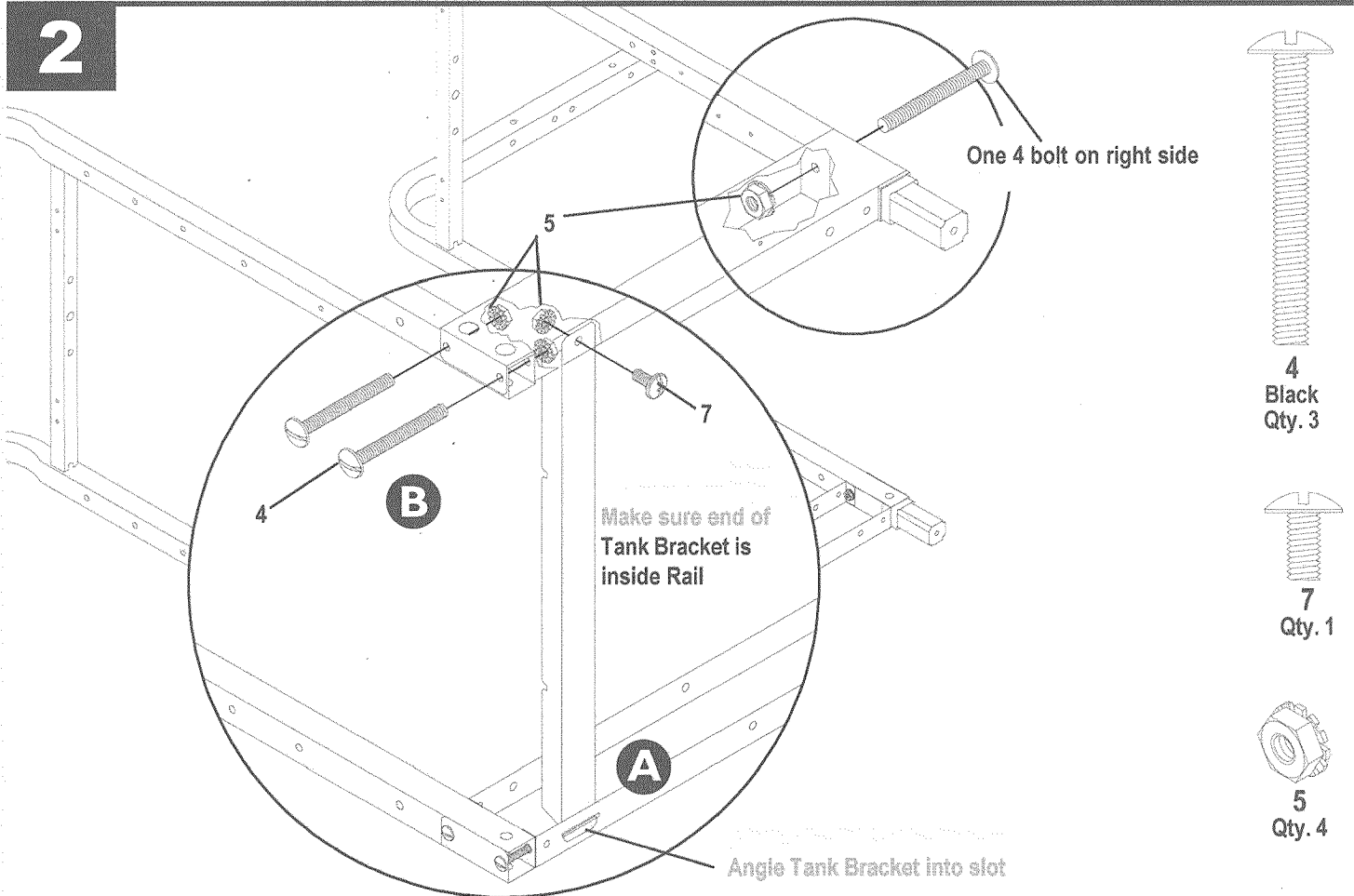

**3**

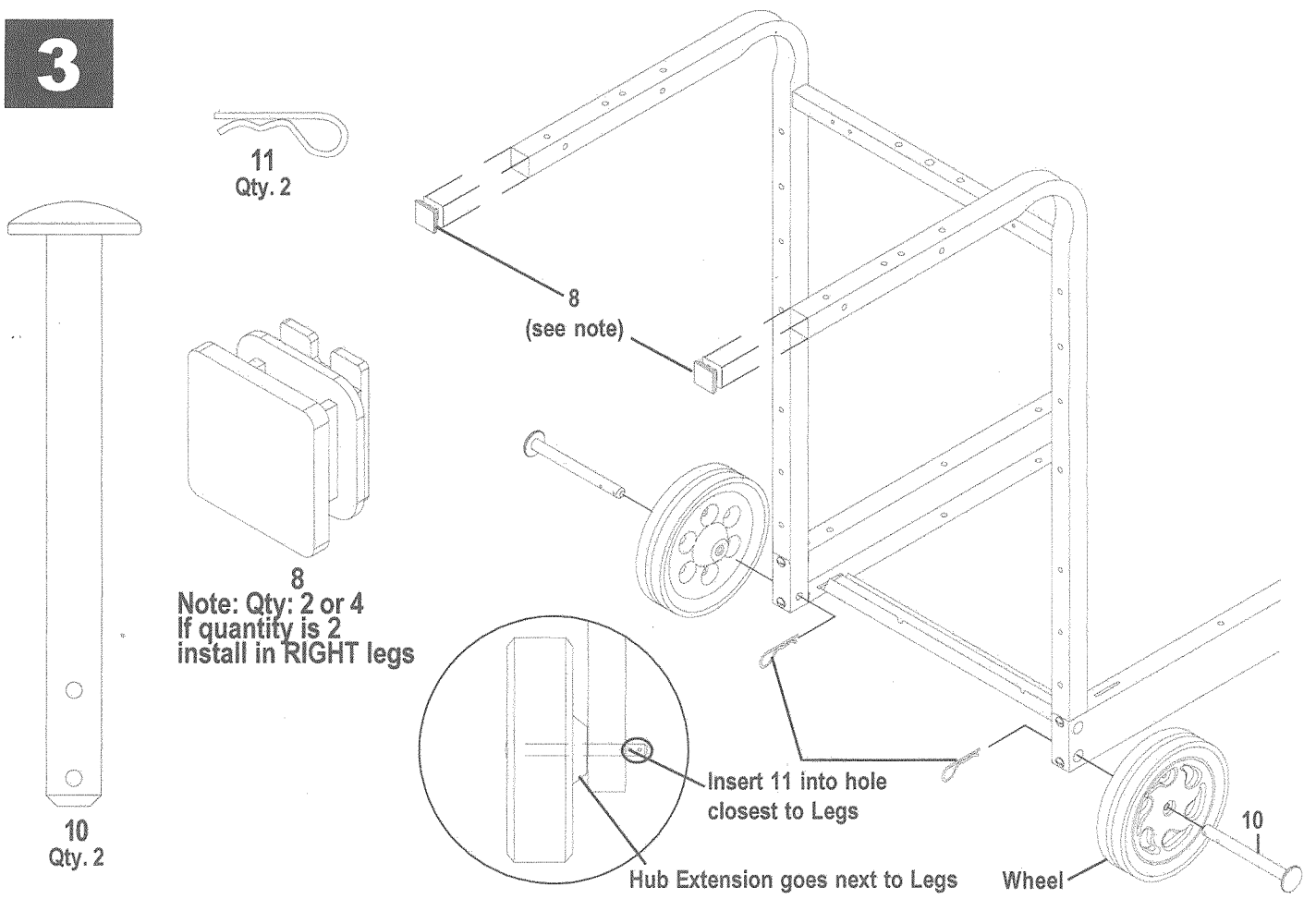

**4**

▲ Fully tighten after Console is attached

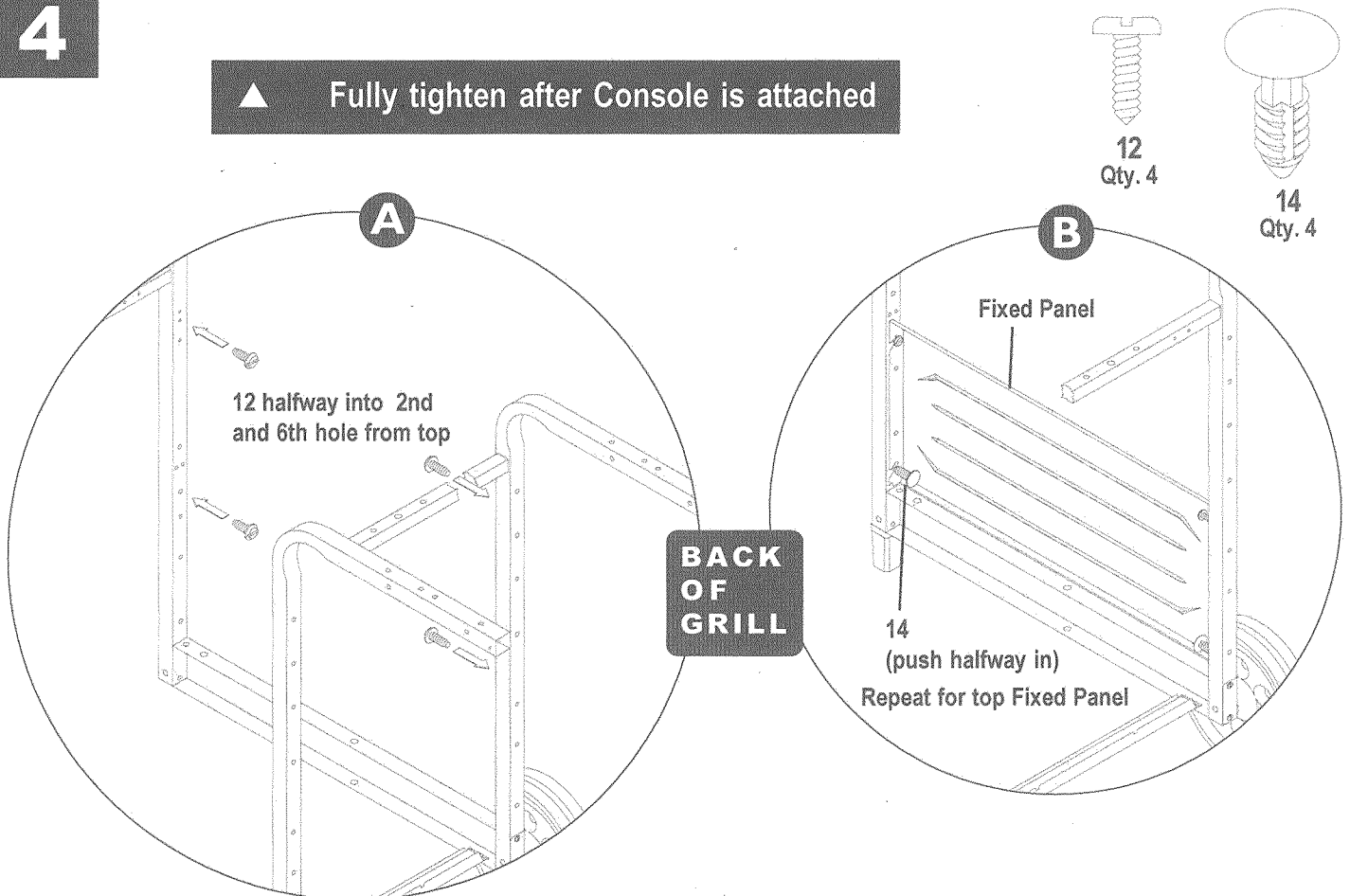

5



▲ Fully tighten screws on the fixed panels.

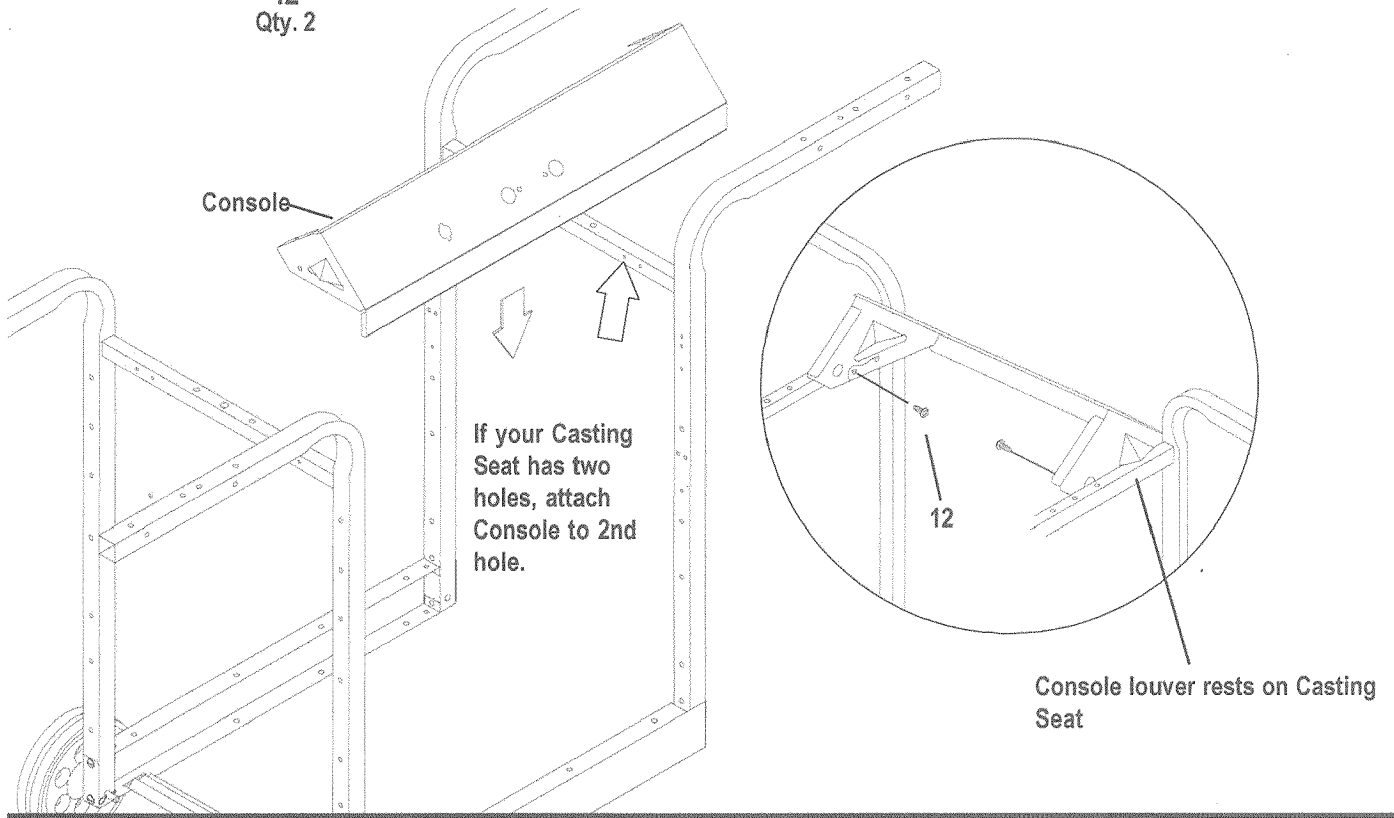

6

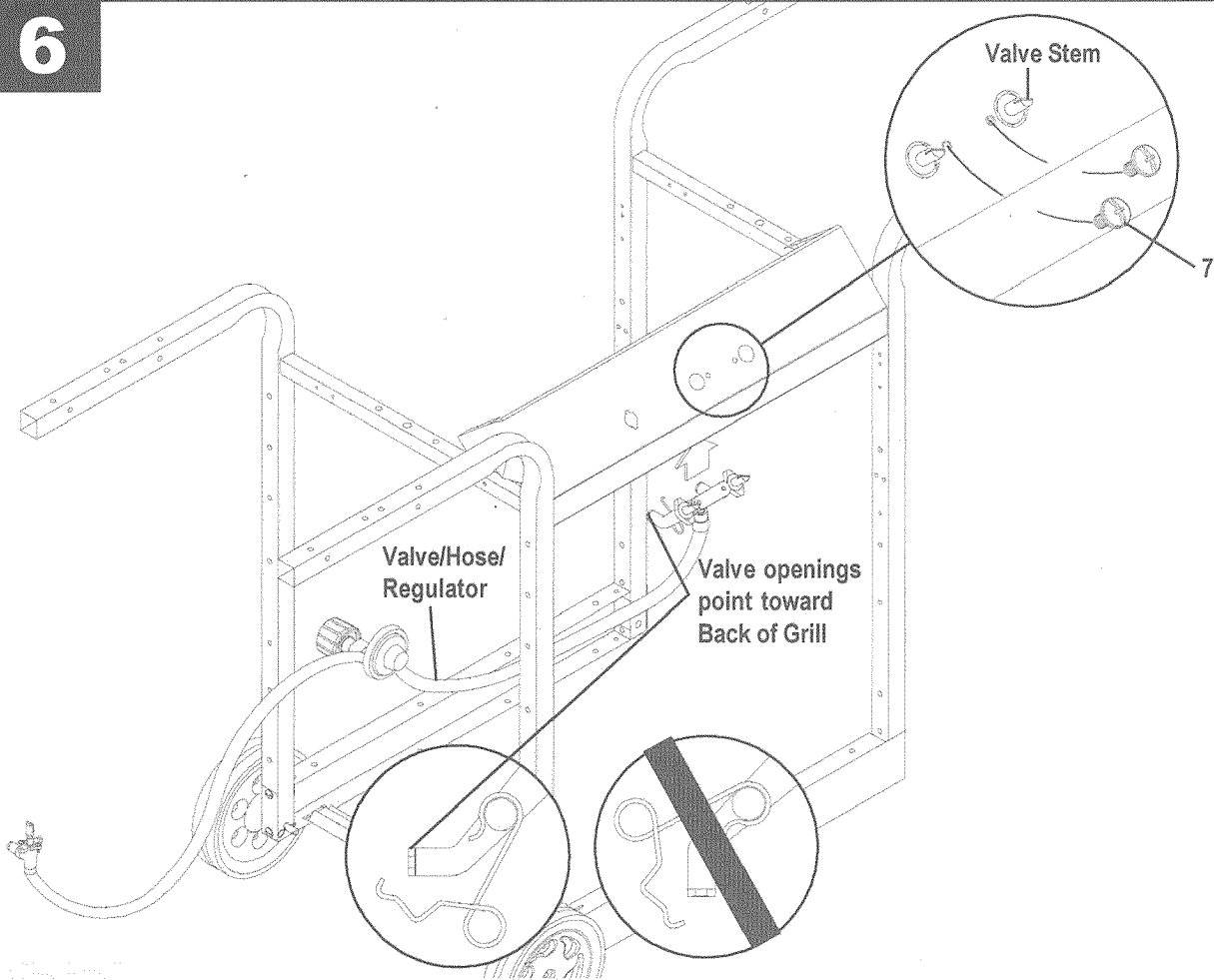
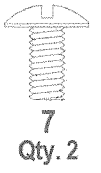

7

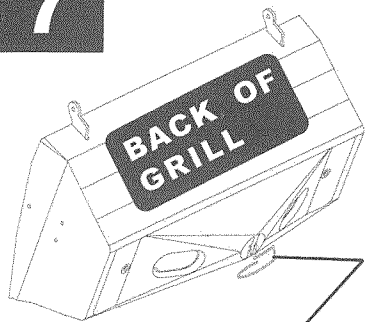

A

▲ Use an empty soup can to hang from the Grease Clip.

### CAUTION

- Failure to install can in clip will cause hot grease to drip from bottom of grill with risk of fire or property damage.

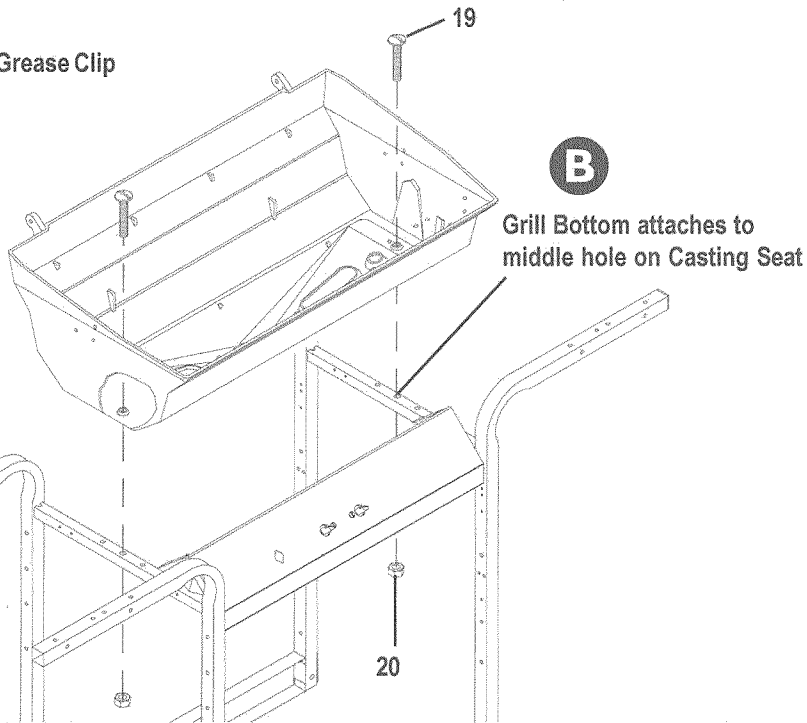

B

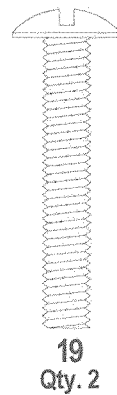

19 Qty. 2



20 Qty. 2

8

▲ VERY IMPORTANT:  
Burner tubes must pass through holes in grill bottom and engage valve attached to console.

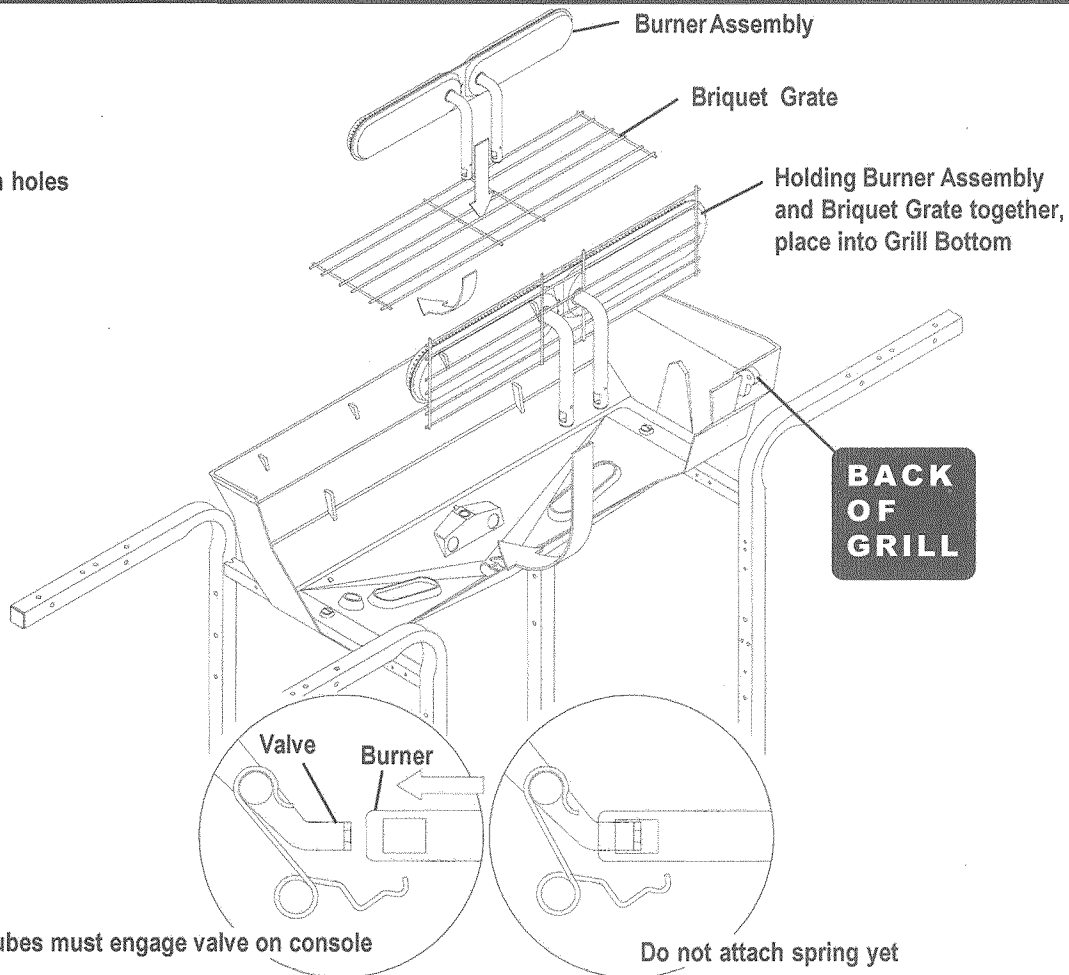

BACK OF GRILL

Burner Tubes must engage valve on console

Do not attach spring yet

# 9

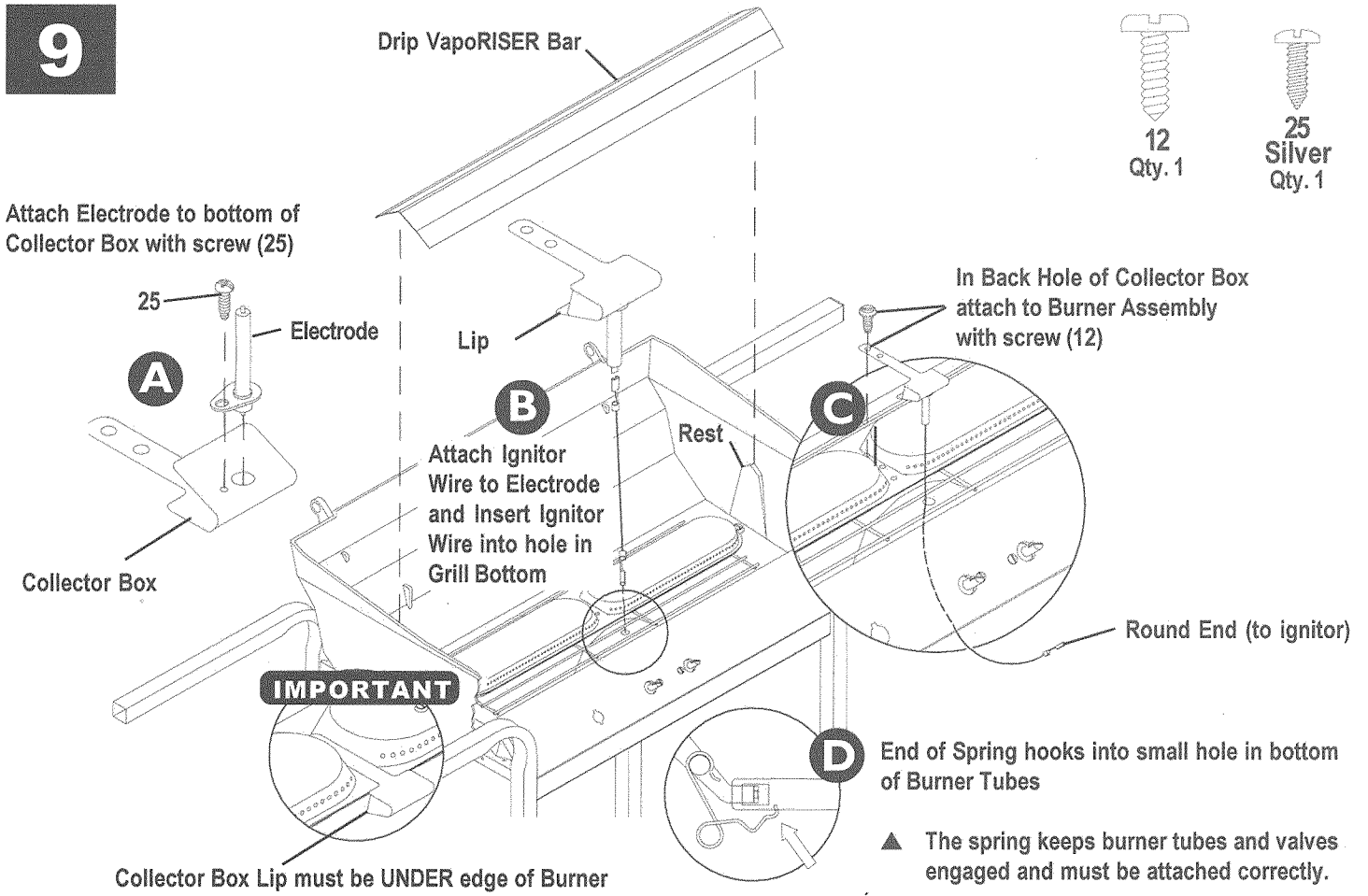

# 10

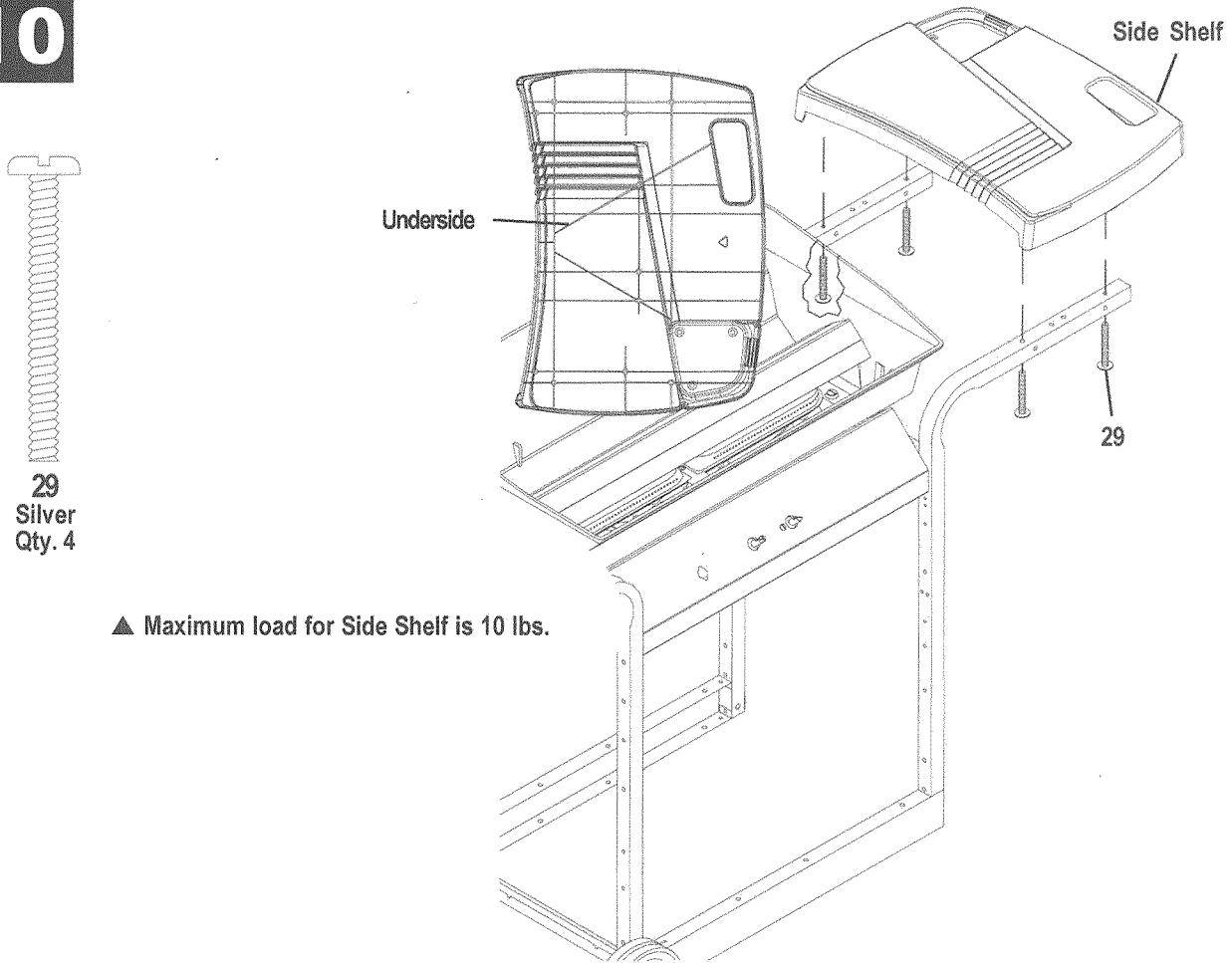

# 11

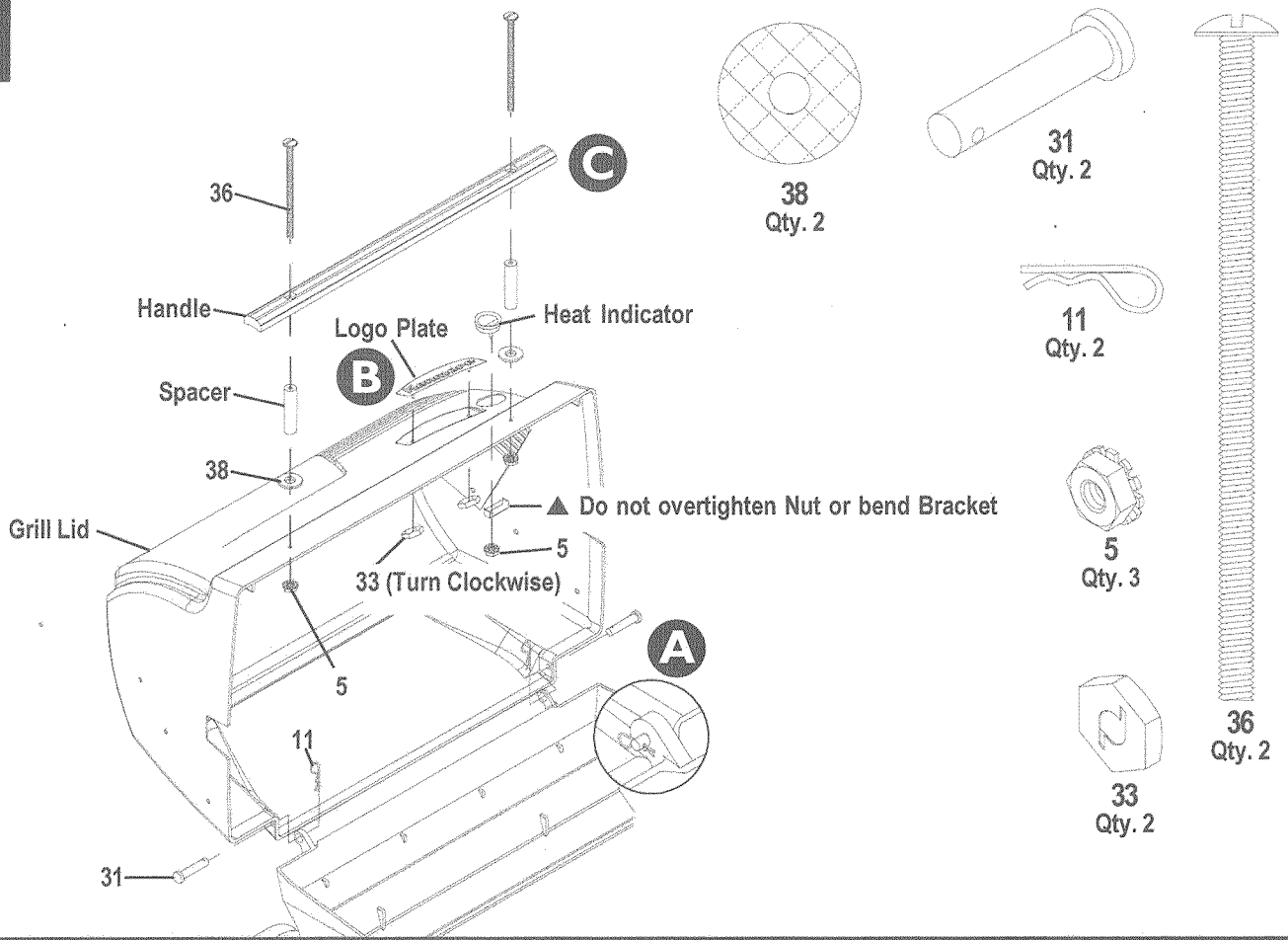

# 12

- ▲ SwingAway will keep food warm, while keeping it away from flames. Do not use SwingAway for cooking meats or heavy food items.
- ▲ Pivot and leg wires must run underneath SwingAway surface.

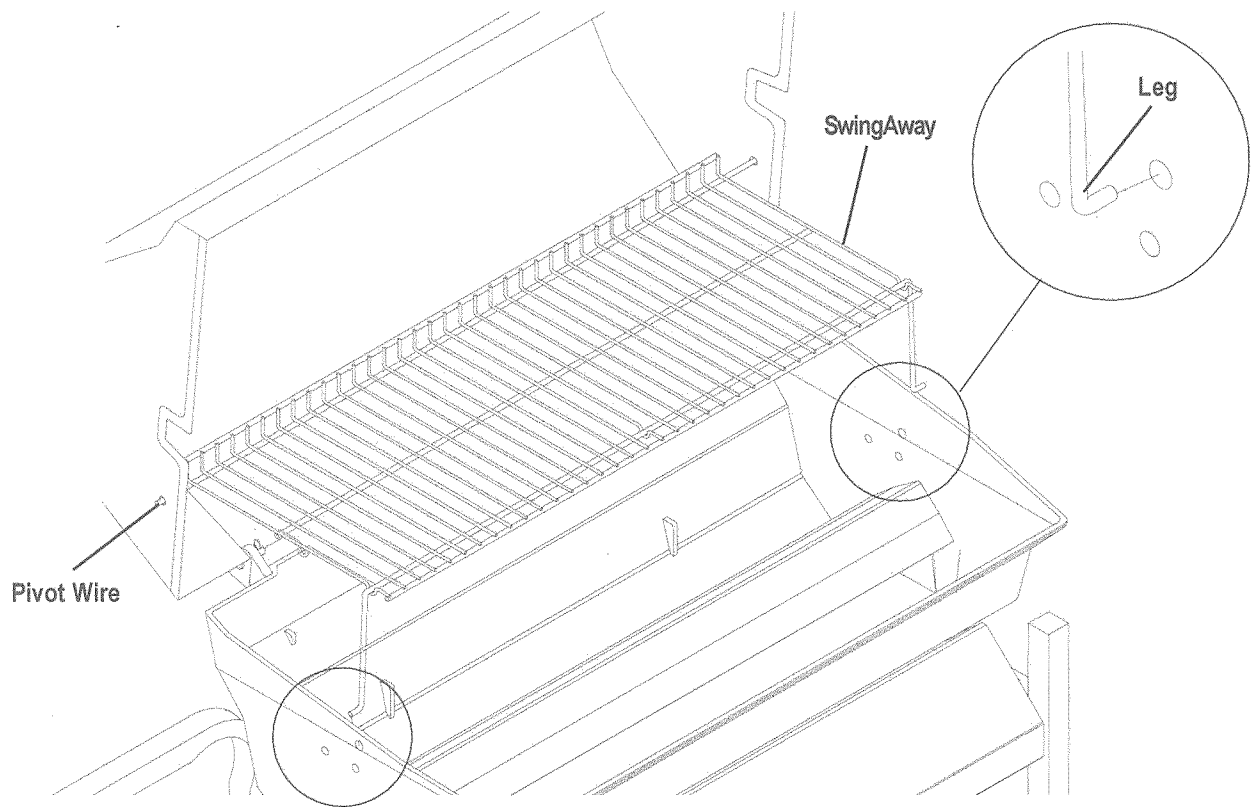





# 15

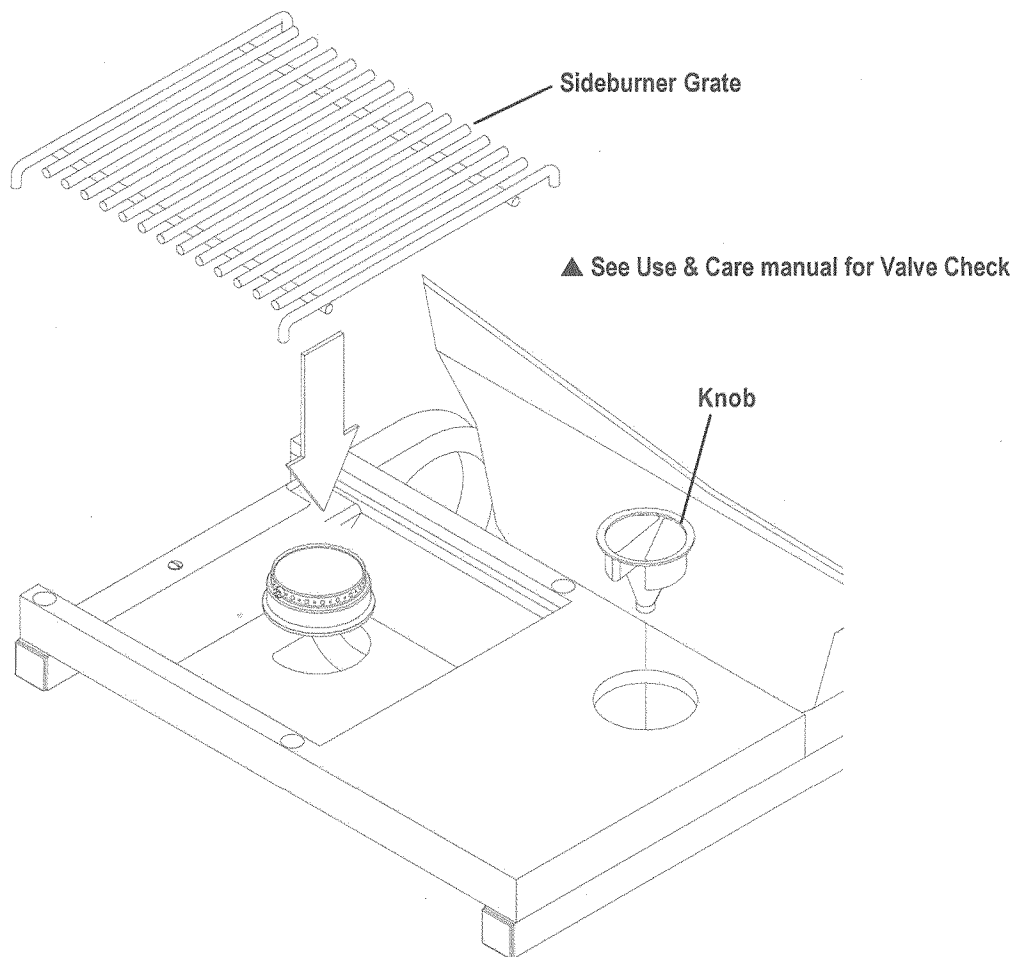

# 16

- ▲ When installing Ignitor do not push on button. This may cause a minor shock.
- ▲ Sideburner electrode wire must be connected to Ignitor for grill and Sideburner to ignite.
- ▲ Ignitor Wire(s) must not come into contact with grill bottom.
- ▲ See Use and Care for Valve Check.

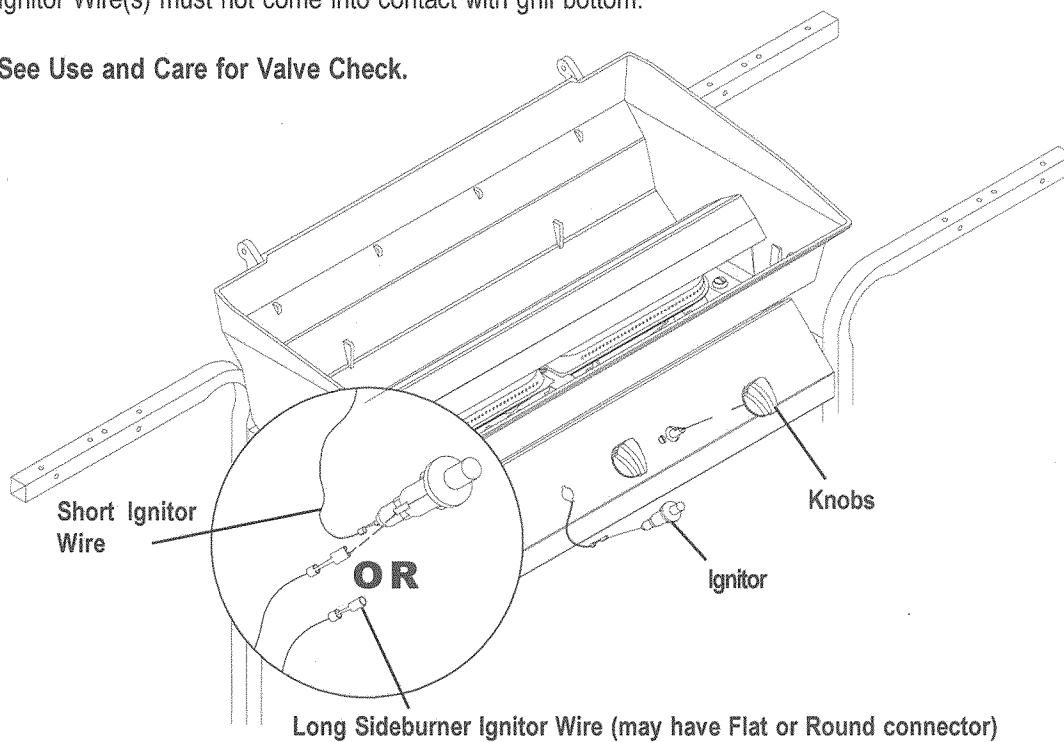

# 17

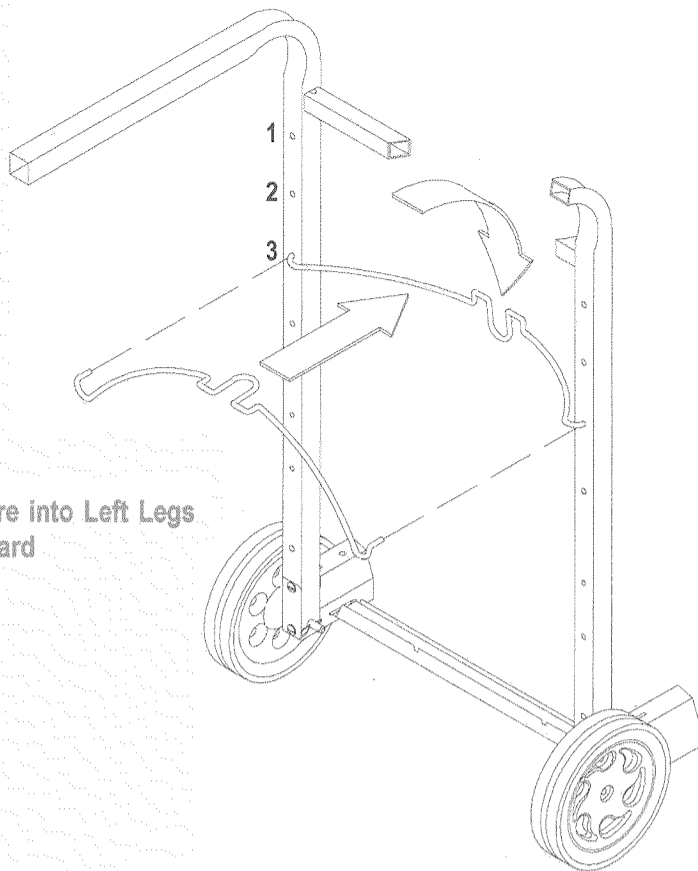

Insert Tank Wire into Left Legs and rotate inward

# 18

▲ LP tank is sold separately. Fill before attaching to grill.

▲ Curved portion of tank wire should be to inside of tank collar.

▲ For filling of tank and connection of tank to regulator, see the Use and Care Manual.

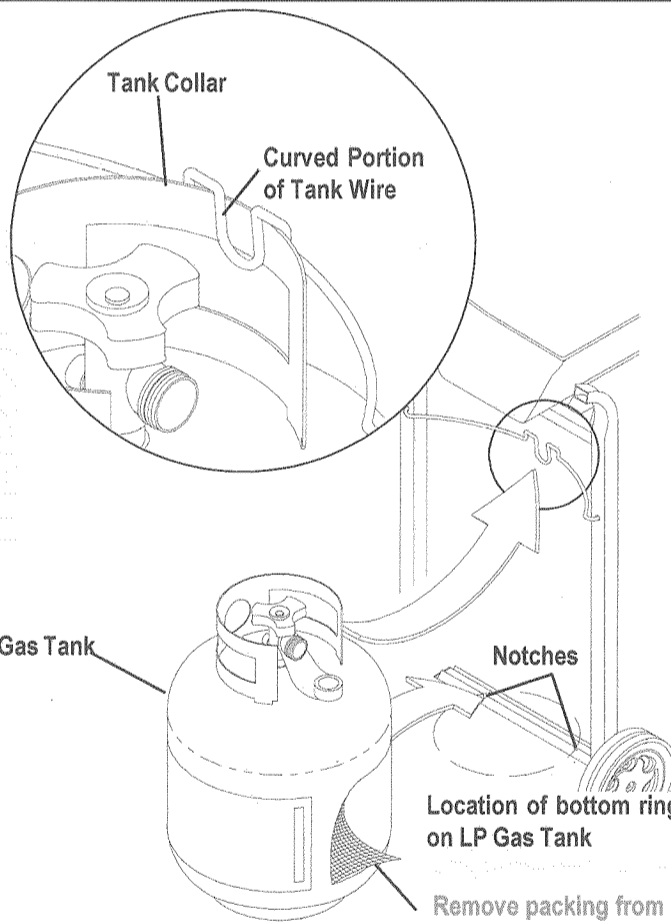

## CAUTION

- Tank collar opening must face to front of cart once tank is attached.
- Failure to install tank correctly may allow gas hose to be damaged in operation.

See Use and Care Manual for important safety instructions before using.

# 19

Perform the "Burner Flame Check" in the Use and Care section.  
▲ Let grill cool before placing briquets.

Place 16 briquets. Do not layer or stack just enough to cover fire grate surface.

▲ Do not let briquets cover burner port holes

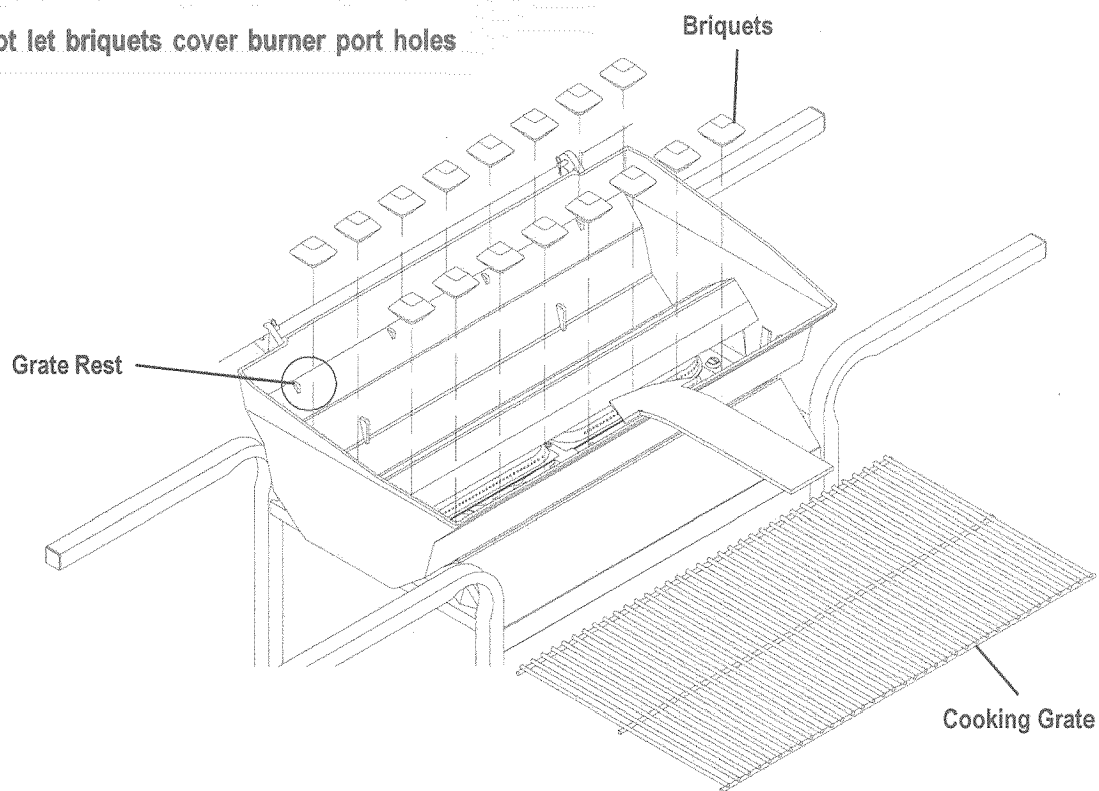



# Recipes

---

## Char-Broil Turkey

Yield: 14 to 16 generous servings or 1 lb. per person

Cooking time: 25 minutes per pound • Method: Grill on low

12 to 14 lb. turkey, thawed completely	vegetable oil
1 large apple, quartered	1 quart water
1-1/2 sticks butter	2 stalks celery, cut in 2" pieces
1 orange, quartered	2 onions, cut in large cubes
1 lemon, thinly sliced or 4 tbs. lemon juice	salt and pepper
cheesecloth (optional)	

Heat grill to medium. Wash and rinse turkey, removing giblets. Dry with absorbent paper. Bend wings back behind turkey. Season inside of turkey with salt and pepper. Rub outside of bird with oil. Stuff with onions, celery, orange and apple. Completely fill cavity (this gives moisture to the turkey). Cover openings of turkey with excess skin. Melt butter in a large aluminum foil pan. Add turkey, water and lemon juice. Place on grill and turn heat to low. Baste with butter, cover top with cheesecloth and baste again. Baste every 1/2 hour until done. Serve with **Giblet Gravy**.

## Giblet Gravy

2 to 3 turkey or chicken giblets	salt and pepper to taste
3-4 tbs. turkey or chicken fat	1/4 tsp. Accent
1/4 cup flour	dash of thyme
2 cups fat-free pan juices	1/8 tsp. Kitchen Bouquet
2 hard boiled eggs, finely chopped	milk, if needed
giblet broth, if needed	

Boil giblets until tender, reserving broth. Chop giblets and set aside. Remove grilled turkey from baking pan and place on hot platter. Pour all pan juices into large measuring cup. Skim off fat, reserving 3 to 4 tbs. Place reserved fat into a deep saucepan, heating over moderate heat. Stir in flour, whisking well with wire whisk. Cook over low heat until bubbly then remove from heat. Add fat-free pan juices (add milk and giblet broth to juices to make 2 full cups). Blend well with wire whisk. Season with salt, pepper, Accent, thyme and Kitchen Bouquet, whisking continuously. Return mixture to heat and continue stirring for 3 to 4 minutes. Add chopped eggs.

## Smoked Turkey Breast

Cooking time: 25 minutes Per Pound • Method: Grill Indirect Heat

1 turkey breast, fresh or thawed	1 large bottle Italian dressing
1 large plastic roasting bag	1 small bottle soy sauce

Mix dressing and soy sauce. Place turkey breast in bag and pour mixture over turkey breast. Marinate in refrigerator overnight. Light one side of grill with setting on low. Remove turkey from marinade and reserve liquid. Put meat thermometer in turkey breast being certain not to touch bone. Place turkey on the grill away from direct heat. Grill over low fire, basting and rotating often. Remove when meat thermometer registers 180°F.

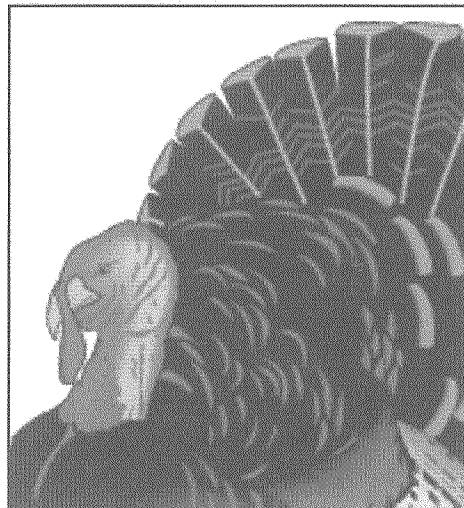



# Recipes

---

## Savory Sirloin Steak

Yield: 4-6 Servings • Cooking Time: 15-25 Minutes • Method: Medium-Hot

1/4 cup Worcestershire sauce	1 (3 lb.) sirloin steak
1 tbs. minced onion	2 tbs. steak sauce
2 tbs. lemon juice	2 tbs. butter, melted
2 tbs. oil	1 tbs. chopped parsley
1 tsp. salt	1 tsp. Worcestershire
1/2 tsp. instant minced garlic	

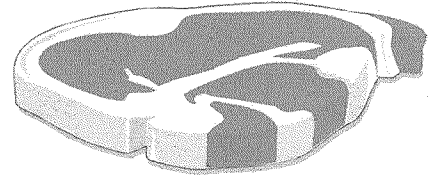

Combine first 6 ingredients. Pour into a heavy plastic bag and add steak. Marinate in refrigerator 4 hours or overnight, turning occasionally. Remove steaks from marinade about 1 hour before grilling. Drain. Place on grill over hot fire. Grill about 8 to 12 minutes on each side, or to desired degree of doneness. Combine remaining ingredients and spoon over steak before serving. Slice steak in thin diagonal slices.

## Teriyaki Steak

Yield: 6-8 Servings • Cooking Time: 30 Minutes • Method: Medium-Hot

1 2 lb. flank steak	1 tsp. ginger	1/4 cup water
1 clove garlic, minced	2 tbs. sugar	2 tsp. meat tenderizer
1/3 cup grated onion	1/2 cup soy sauce	1 tsp. Liquid Smoke

Score steak in diamond pattern on both sides. Place steak in heavy plastic bag. Combine marinade ingredients and pour over steaks. Marinate at room temperature 2 to 3 hours, or in refrigerator overnight, turning occasionally. Allow steak to come to room temperature before grilling. Reserve marinade. Place on grill over medium-hot fire and grill with lid down for 15 minutes, basting often. Turn and grill another 15 minutes or until done to your liking. Continue basting.

## Eye of Round

Yield: 6 Servings • Cooking Time: About 1-1/4 Hours • Method: Low-Medium

1 (3 lb.) eye of round	1/3 cup wine vinegar
2/3 cup Worcestershire sauce	2/3 cup salad oil
1/3 cup soy sauce	

Marinate roast overnight in above mixture. Cook over low fire until done. Check after 1 hour for medium rare. Slice very thin and serve with **Horseradish Sauce**.

## Horseradish Sauce

Yields: 1-1/2 cups

Combine all ingredients in blender.	1 (3 oz.) pkg. cream cheese	2 tbs. horseradish	1 cup sour cream
1/4 tsp. each : sugar, salt and pepper	1 tsp. grated onion		



# Recipes

---

## Indirect Cooking:

You can bake or slowly roast many foods on a covered grill by cooking indirectly. Simply light the gas on one side of the grill and place the food on the other side. Close the lid and your grill will bake or roast like a conventional oven.

### Lemon Herb Chicken

Yield: 6 Servings • Cooking Time: 45 Minutes • Method: Low

1/2 cup fresh lemon juice	Grated rind of 1 lemon
1-1/2 tsp. crushed sweet basil	1/2 tsp. crushed thyme
2 cloves garlic, crushed	2 tsp. salt
1 tsp. paprika	1 cup oil
1-1/2 tsp. onion powder	1 cut up frying chicken

Combine all ingredients and pour into plastic bag. Add chicken and marinate for 6 to 8 hours in refrigerator, turning occasionally. Remove from refrigerator 1 hour before grilling. Place chicken on grill, skin-side up. Cook for 20 to 25 minutes, basting often with marinade. Turn, cook for 20 minutes longer. Serve immediately.

### Polynesian Chicken

Yield: 4 Servings • Cooking Time • 1 to 1-1/2 Hours • Method: Low

2 (2 Lb.) split broilers	2 tsp. salt
1/2 cup oil	1/2 tsp. pepper

Brush chicken with oil and season with salt and pepper. Place on grill with bone side down. Grill slowly. Turn after 20 to 25 minutes and cook about 20 minutes longer. Meanwhile make the below listed glaze.

### Pineapple Glaze

1 cup crushed pineapple, drained and reserve 1/4 cup syrup	2 tbs. prepared mustard
2 tbs. lemon juice	1/2 tsp. salt
	1 cup brown sugar

Combine ingredients, brush both sides of chicken with glaze and broil about 10 minutes more or until tender. Turn and baste with glaze. Serve extra glaze with chicken.

### Chicken Shish Kabobs

Yield: 4 Servings • Cooking Time: 12-16 Minutes • Method: Medium

4 chicken breast halves, boned and cut into 1-1/2 inch pieces	1 cup soy sauce
1 green pepper, cut in 1 inch pieces	1/2 lb. mushrooms
1 zucchini squash sliced and parboiled	1 small can pineapple chunks, juice reserved

Combine all but pineapple chunks (include the pineapple juice). Marinate for 8 to 12 hours in refrigerator. Thread chicken, pineapple, mushrooms and bell pepper alternately on skewers. Grill over medium fire for 6 to 8 minutes on each side or until done.

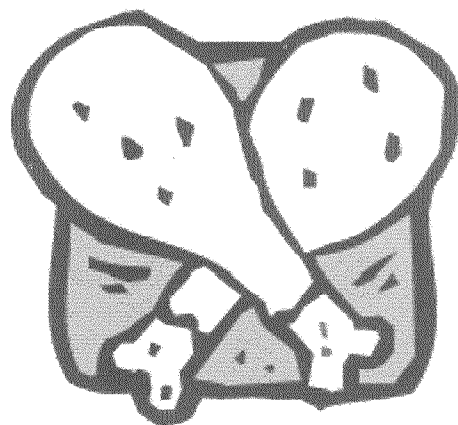

**For the repair or replacement parts you need  
delivered directly to your home**

Call 7 am - 7 pm, 7 days a week

**1-800-366-PART**

(1-800-366-7278)

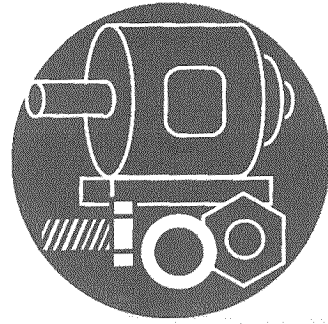

**For in-home major brand repair service**

Call 24 hours a day, 7 days a week

**1-800-4-REPAIR**

(1-800-473-7247)



**For the location of a  
Sears Parts and Repair Center in your area**

Call 24 hours a day, 7 days a week

**1-800-488-1222**



**For information on purchasing a Sears  
Maintenance Agreement or to inquire  
about an existing Agreement**

Call 9 am - 5 pm, Monday-Saturday

**1-800-827-6655**



When ordering repair parts always give the following  
information:

- Model Number
- Part Number
- Name of Item
- Part Description

