

Safety Instructions & Operator's Manual for

SNAPPER®

21" STEEL DECK

WALK MOWERS

COMMERCIAL MODELS

SERIES 19



Models

CRP216019KWV (7800200)

CP216019KWV (7800194)

CP215519HV (7800038)

NOTE: Specifications are correct at time of printing and are subject to change without notice.

* Actual sustained engine power will likely be lower due to operating limitations and environmental factors. Please refer to 'Engine Power Rating Information' for further details.

Thank You for purchasing this quality-built Snapper product. We're pleased that you placed your confidence in the Snapper brand. When operated and maintained according to the instructions in this manual, your Snapper product will provide many years of dependable service.

This manual contains safety information to make you aware of the hazards and risks associated with the machine and how to avoid them. This machine is designed and intended only for finish cutting of established lawns and is not intended for any other purpose. It is important that you read and understand these instructions thoroughly before attempting to start or operate this equipment. Save these instructions for future reference.

PRODUCT REGISTRATION

IMPORTANT: KEEP THIS INFORMATION FOR YOUR PERSONAL RECORDS
(Complete the following information on your Snapper purchase)

Date of Purchase _____

Retailer _____

Retailer's Phone Number _____

Equipment

Model Number _____

Serial Number _____

Engine

Model _____ Type _____ Trim _____

It is very important that you register your purchase with Snapper to ensure warranty coverage. Please mail your product registration card to:



Snapper at P.O. Box 777, McDonough, Georgia 30253.



Or you may register online at www.snapper.com.

You can contact us at our website, or if you would like to speak with a Customer Service Representative, call us at the Snapper Customer Relations Center at 1-800-935-2967. For faster service please have your Serial Number and Model Number available.

Table of Contents

Operator Safety2
Important Operator Safety Instructions2
Features and Controls4
Operation5
Pre-Start Checklist5
Starting & Stopping Engine & Blades5
Propelling Mower6
Handle Height Adjustment6
Cutting Height Adjustment7
Recycling Operation7
Removing the Recycling Cover7
Installing the Discharge Deflector8
Installing the Grass Bag Adapter8
Installing the Grass Bag10
Dumping the Grass Bag10
Maintenance11
Change Engine Oil11
Check Transmission Grease11
Check Mower Blade12
Check Engine Drive Belt12
Check Transmission Belt12
Service - Periodic12
Engine12
Air Filter12
Engine Oil12
Storage Procedure12
Mower Blade Replacement13
Blade Sharpening13
Wheel Drive Control Adjustment14
Driven and Drive Disc Service15
Belt Service18
Engine Drive Belt Replacement18
Transmission Belt Replacement19
Service Schedule20
Troubleshooting21
Warranty22

 **WARNING** 
 Battery posts, terminals and related accessories contain lead and lead compounds, chemicals known to the State of California to cause cancer and birth defects or other reproductive harm. Wash hands after handling.

 **WARNING** 
 Engine exhaust, some of its constituents, and certain vehicle components contain or emit chemicals known to the State of California to cause cancer or other reproductive harm.



Important Operator Safety Instructions



WARNING: This powerful cutting machine is capable of amputating hands and feet and can throw objects that can cause injury and damage! Failure to comply with the following SAFETY instructions could result in serious injury or death to the operator or other persons. The owner of the machine must understand these instructions and must allow only persons who understand these instructions to operate machine. Each person operating the machine must be of sound mind and body and must not be under the influence of any substance, which might impair vision, dexterity or judgment. If you have any questions pertaining to your machine which your dealer cannot answer to your satisfaction, call or write the Customer Service Department at SNAPPER, McDonough, Georgia 30253. Phone: (1-800-935-2967).

Protection for Children

Tragic accidents can occur if the operator is not alert to the presence of children. Children are often attracted to the machine and the mowing activity. Never assume that children will remain where you last saw them.

1. KEEP children out of the mowing area and under the watchful care of a responsible adult other than the operator.
2. DO NOT allow children in yard when machine is operated and turn machine OFF if anyone enters the area.
3. DO NOT allow pre-teenage children to operate machine.
4. ALLOW only responsible adults & teenagers with mature judgment under close adult supervision to operate machine.
5. DO NOT pull mower backwards unless absolutely necessary. LOOK and SEE behind and down for children, pets and hazards before and while backing.
6. USE EXTRA CARE when approaching blind corners, shrubs, trees, or other objects that may obscure vision.

Slope Operation

1. Slopes are a major factor related to slip and fall accidents, which can result in severe injury. All slopes require extra caution. If you feel uneasy on a slope, DO NOT mow it.
2. Mow across slopes, never up-and-down. Exercise extreme CAUTION when changing directions on slopes. DO NOT mow steep slopes or other areas where stability or traction is in doubt. Refer to the Slope Guide at the end of this manual.
3. Use extra care with grass catchers or other attachments; these affect the handling and the stability of the machine.

Preparation

1. Read, understand, and follow instructions and warnings in this manual and on the mower, engine and attachments. Know the controls and the proper use of the mower before starting.
2. Only mature, responsible persons shall operate the machine and only after proper instruction.
3. Data indicates that operators age 60 and above, are involved in a large percentage of mower-related injuries. These operators should evaluate their ability to operate the mower safely enough to protect themselves and others from serious injury.

Preparation

(Continued From Previous Column)

4. Handle fuel with extra care. Fuels are flammable and vapors are explosive. Use only an approved fuel container. DO NOT remove fuel cap or add fuel with engine running. Add fuel outdoors only with engine stopped and cool. Clean spilled fuel and oil from machine. DO NOT smoke.
5. Check the area to be mowed and remove all objects such as toys, wire, rocks, limbs and other objects that could cause injury if thrown by blade or interfere with mowing. Also note the location of holes, stumps, and other possible hazards.
6. Keep people and pets out of the mowing area. Immediately, STOP Blade, Stop engine and Stop mower if anyone enters the area.
7. Check shields, deflectors, switches, blade controls and other safety devices frequently for proper operation and location.
8. Make sure all safety decals are clearly legible. Replace if damaged.
9. Protect yourself when mowing and wear safety glasses, a dust mask, long pants, and substantial footwear. DO NOT mow barefooted or with sandals.
10. Know how to STOP blade and engine quickly in preparation for emergencies.
11. Use extra care when loading or unloading the machine into a trailer or truck.
12. Check grass catcher components frequently for signs of wear or deterioration and replace as needed to prevent injury from thrown objects going through weak or torn spots.

Safe Handling of Gasoline

To avoid personal injury or property damage, use extreme care in handling gasoline. Gasoline is extremely flammable and the vapors are explosive.

1. Extinguish all cigarettes, cigars, pipes and other sources of ignition.
2. Use only an approved fuel container.
3. DO NOT remove fuel cap or add fuel with the engine running. Allow the engine to cool before refueling.
4. DO NOT refuel the machine indoors.
5. DO NOT store the machine or fuel container inside where there is an open flame, spark or pilot light such as on a water heater or other appliances.



Important Operator Safety Instructions (Continued)



Safe Handling of Gasoline (Continued From Previous Page)

6. DO NOT fill fuel containers inside a vehicle or on a truck or trailer bed with a plastic liner. Always place the containers on the ground away from the vehicle before filling.
7. Remove gas-powered equipment from the vehicle or trailer and refuel it on the ground. If this is not possible, then refuel equipment using a portable container, rather than a gasoline dispenser nozzle.
8. DO NOT start gas powered equipment in enclosed vehicles or trailers.
9. Keep the nozzle in contact with the rim of the fuel tank or container opening at all times until fueling is complete. DO NOT use a nozzle lock-open device
10. If fuel is spilled on clothing, change clothing immediately.
11. DO NOT overfill a fuel tank. Replace fuel cap and tighten securely.

Operation

1. DO NOT put hands or feet near or under rotating parts. Keep clear of discharge area while engine is running.
2. STOP engine when crossing gravel drives, walks, or roads, and under any conditions where thrown objects might be a hazard.
3. Mow only in daylight or good artificial light.
4. DO NOT operate mower while under the influence of alcohol or drugs.
5. After striking a foreign object or if mower vibrates abnormally, STOP the engine, disconnect and secure spark plug wire. Inspect the mower for any damage and repair the damage before starting.
6. DO NOT mow near drop offs, ditches or embankments. Operator could lose footing or balance.
7. STAY ALERT for holes and other hidden hazards. Tall grass can hide obstacles. Keep away from ditches, washouts, culverts, fences and protruding objects.
8. DO NOT mow on wet grass. Always be sure of your footing. Keep a firm hold on the handle and walk, never run. Slipping could cause injury.
9. ALWAYS stay behind handle when engine (motor) is running.
10. DO NOT leave the machine with the engine running. STOP BLADE and STOP ENGINE before leaving the operators position for any reason.
11. Before cleaning, repairing or inspecting make certain engine, blade and all moving parts have STOPPED. Disconnect and secure spark plug wire away from plug to prevent accidental starting.
12. STOP engine and wait until the blade comes to complete STOP before removing grass bag and/or clearing grass.

Operation (Continued From Previous Column)

13. DO NOT operate mower without the entire grass catcher, or guards in place discharge guard, rear guard or other safety devices in place and working. DO NOT point discharge at people, passing cars, windows or doors.
14. DO NOT discharge material against a wall or obstruction. Material may ricochet back towards the operator.
15. Slow down before turning.
16. Watch out for traffic when near or crossing roadways.
17. DO NOT operate engine in enclosed areas. Engine exhaust gases contain carbon monoxide, a deadly poison.
18. Only use accessories approved by the manufacturer. See manufacturer's instructions for proper operation and installation of accessories.

Maintenance and Storage

1. DO NOT store mower or fuel container inside where fumes may reach an open flame, spark or pilot light such as in a water heater, furnace, clothes dryer or other gas appliance. Allow engine to cool before storing machine in an enclosure. Store fuel container out of reach of children in a well ventilated, unoccupied building.
2. Keep mower and engine free of grass, leaves or excess grease to reduce fire hazard and engine overheating.
3. When draining fuel tank, drain fuel into an approved container outdoors and away from open flame.
4. Keep all bolts, especially blade bolts, nuts and screws properly tight. Check that all cotter pins are in proper position.
5. Always provide adequate ventilation when running engine. Engine exhaust gases contain carbon monoxide, a deadly poison.
6. Service engine and make adjustments only when engine is stopped. Removed spark plug wire from spark plug and secure wire away from spark plug to prevent accidental starting.
7. DO NOT change engine governor speed settings or overspeed engine.
8. Check grass bag assembly frequently for wear or deterioration to avoid thrown objects and exposure to moving parts. Replace with new bag if loose seams or tears are evident. Replace slider or bag adapter if broken or cracked.
9. Mower blades are sharp and can cut. Wrap the blades or wear heavy leather gloves and use CAUTION when handling them.
10. DO NOT test for spark by grounding spark plug next to spark plug hole; spark plug could ignite gas exiting engine.
11. Have machine serviced by an authorized SNAPPER dealer at least once a year and have the dealer install any new safety devices.
12. Use only genuine SNAPPER replacement parts to assure that original standards are maintained.

Features and Controls

IMPORTANT

The figures and illustrations in this manual are provided for reference only and may differ from your specific model. Contact your Snapper dealer if you have questions.



Features and Controls

- | | | | |
|----|-----------------------------------|----|----------------------|
| A. | Oil Fill Cap and Dipstick | F. | Blade Control |
| B. | Fuel Filler Cap | G. | Rope Start Handle |
| C. | Grass Bag Adapter | H. | Ground Speed Control |
| D. | Rear Height Adjustment Latch (2) | I. | Drive Wheel Control |
| E. | Front Height Adjustment Latch (2) | J. | Engine Speed Control |
| | | K. | Grass Bag |

Operation

Pre-Start Check List

Make the following checks and perform the service required before each start-up.

1. Check the guards, deflectors, grass bag, adapter, and covers to make sure all are in place and securely tightened.
2. Check the blade control (**A, Figure 1**), wheel drive control (**B**), and ground speed control (**C**) to insure they work freely.

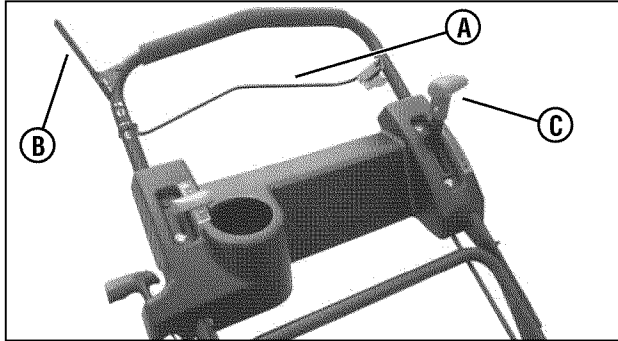

Figure 1: Mower controls

3. Check the cutting height. Adjust to the desired height. Refer to the Section entitled 'Cutting Height Adjustment'.
4. Check the engine oil (**A, Figure 2**) and add oil as needed to bring the level up to the full mark. Refer to the Engine Owner's Manual for oil specifications.

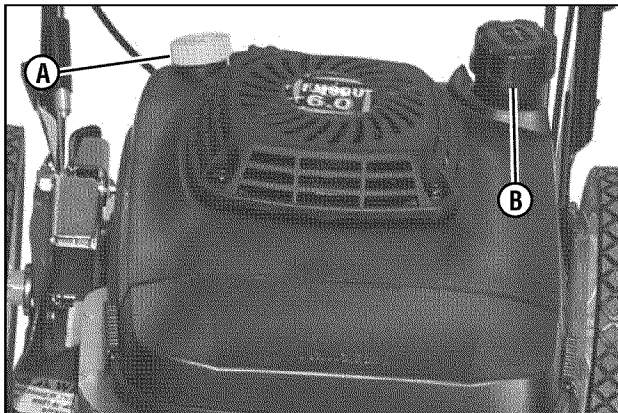

Figure 2: Oil and fuel fill

5. Add fuel to the tank after pushing the mower outside where fumes can safely dissipate. Fill the tank to 1-1/2 inches below the top of the filler neck (to allow for fuel expansion). Make sure the cap (**B, Figure 2**) is tightened after fueling. Refer to the Engine Owners Manual for fuel specifications.
6. Clean the exterior surfaces of the cutting deck and engine of any accumulation of spilled fuel, dirt, grass, oil, etc. Keep the engine air intake screen and cooling fins clear at all times.

Starting and Operation

Engine and Blade

1. Make sure the fuel valve (**A, Figure 3**) on the engine is open.

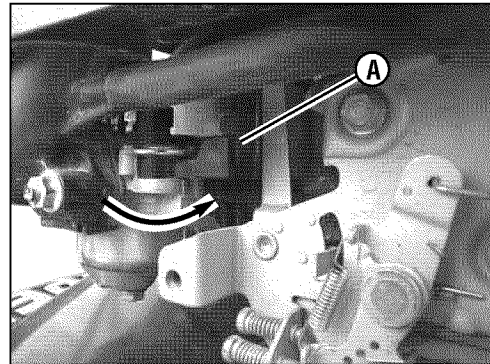
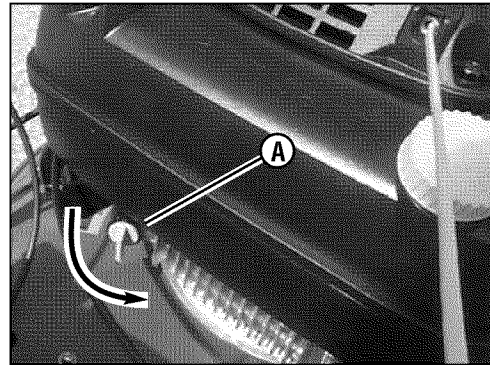

Figure 3: Fuel shut-off

(Kawasaki above, Honda below)

2. Move the engine speed control past the fast ('Rabbit') detent to the 'Choke' position.
3. Pull the blade control (**A, Figure 4**) against the handle.
4. Pull the rope start handle (**B**) to crank the engine.

Operation

Operation (Continued)

Starting and Operation (Continued)

5. After the engine starts, turn off choke and allow a brief warm-up until the engine runs smooth before beginning mower operation.

NOTE: To stop the engine (and blade), release the blade control.

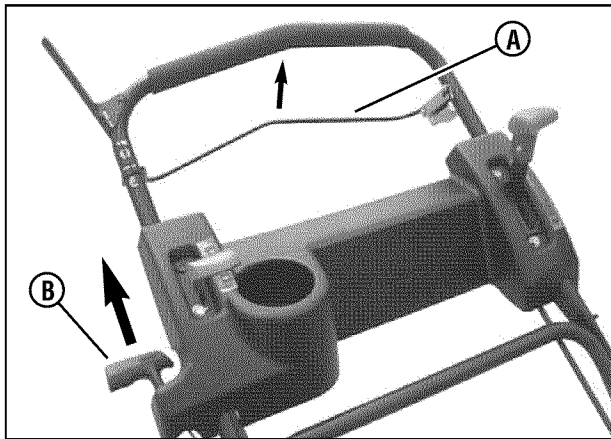

Figure 4: Starting the mower

Propelling the Mower

1. Start the engine. Refer to the Section entitled “Starting and Operation – Engine and Blade”.
2. Move the ground speed control (**A**, Figure 5) to the desired speed position.
3. Squeeze the wheel drive control (**B**) against the handle to engage the wheel drive and propel the mower forward. Forward speed can be adjusted while the mower is moving by changing the position of the ground speed control.

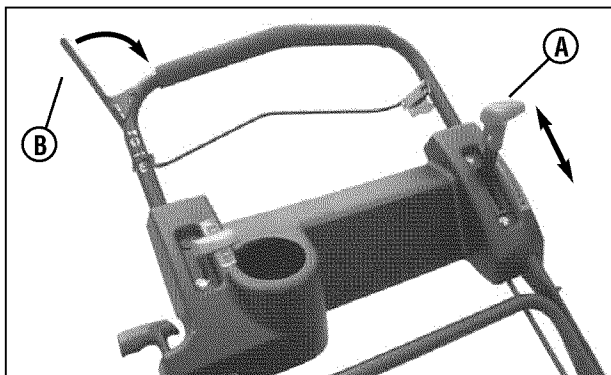

Figure 5: Mower drive controls

Stopping

1. Stop forward motion of the mower by releasing the wheel drive control.
2. Stop the engine and blade by releasing the blade control.

Handle Height Adjustment

The height of the mower handle can be adjusted as follows:

1. Loosen the lower nuts (**A**, Figure 6) on each lower handle.

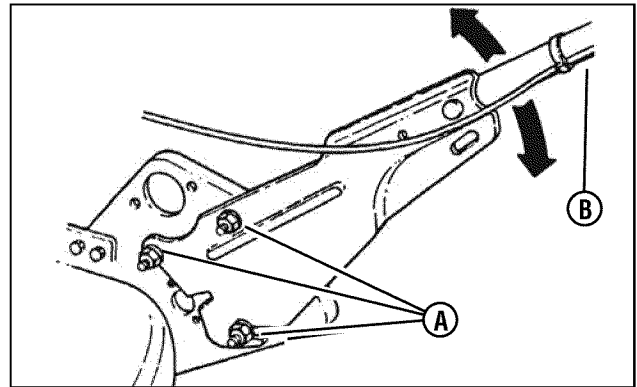

Figure 6: Adjusting the handle height

2. Move the handle assembly (**B**) up or down until the desired position is achieved.
3. Tighten the lower nuts on each lower handle to maintain the desired position.



WARNING



DO NOT attempt any maintenance, adjustments or service with engine and blade running. STOP engine and blade. Disconnect spark plug wire and secure away from spark plug. Engine and components are HOT. Avoid serious burns, allow sufficient time for all components to cool.

Operation (Continued)



WARNING



DO NOT attempt any maintenance, adjustments or service with engine and blade running. STOP engine and blade. Disconnect spark plug wire and secure away from spark plug. Engine and components are HOT. Avoid serious burns, allow sufficient time for all components to cool.

Cutting Height Adjustment

1. Pull the height adjusting latch (A, Figure 7) outward and move to the desired cutting height.

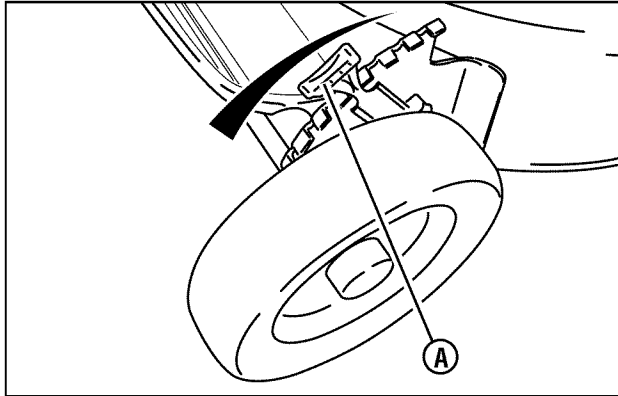

Figure 7: Adjusting cutting height

2. Set all wheels at the same cutting height. The highest cutting position is Notch 7 (Figure 8). The lowest cutting position is Notch 1.

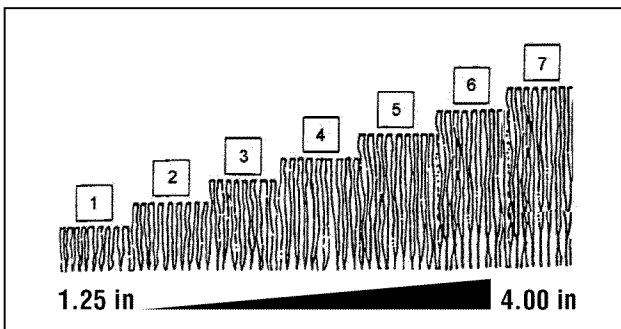

Figure 8: Cutting height settings (approximate)



WARNING



Stop engine and mower blade by releasing the blade control before adjusting cutting height.

Recycling Operation

Note: For best recycling results, cut up to a maximum of 1/3 of grass blade length and recycle ONLY when grass is dry.

1. Set all wheels in the highest cutting position (Notch 7). Refer to the Section entitled “Cutting Height Adjustment”.
2. Move the engine speed control to the fast (Rabbit) position.
3. Move the ground speed control to the slowest speed setting.
4. Proceed mowing slowly. If the grass is very dense, lower each rear wheel latch one notch lower than the front wheel latches to improve recycling performance.

Note: The recycling cover should remain on the machine at all times, unless alternate discharge operations are desired, such as side discharging or bagging.

Removing the Recycling Cover

1. Remove the nuts (A, Figure 9) securing the recycling cover (B) to the mower deck.
2. Remove the cover.

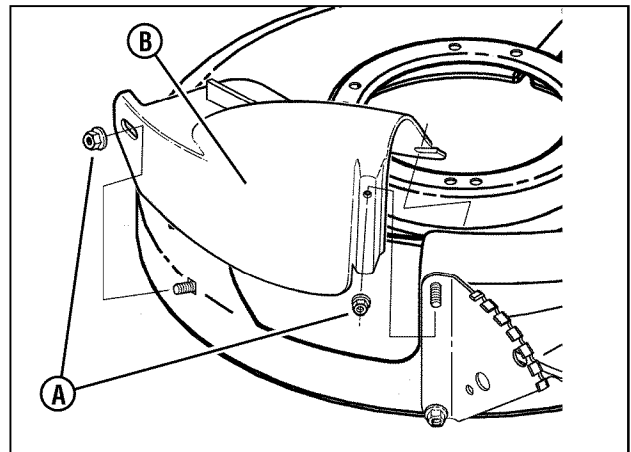

Figure 9: Removing the recycling cover

Operation (Continued)



WARNING



DO NOT attempt any maintenance, adjustments or service with engine and blade running. STOP engine and blade. Disconnect spark plug wire and secure away from spark plug. Engine and components are HOT. Avoid serious burns, allow sufficient time for all components to cool.

Installing the Discharge Deflector

1. Remove the recycling cover. Refer to the Section entitled "Recycling Operation".
2. Install the deflector (**A, Figure 10**) to the deck in place of the recycling cover, making sure that:
 - The front hole (**B**) on the outside front of the deflector fits over the stud where the front of the recycling cover was originally secured
 - The slot (**C**) on top of the deflector slips under the restraining nut on top of the deck (under the right front corner of the engine)
 - The slot (**D**) on the inside rear of the deflector slips onto the stud behind the rear of the discharge opening, where the rear of the recycling cover was originally secured.
3. Install the nuts onto the studs and tighten securely.

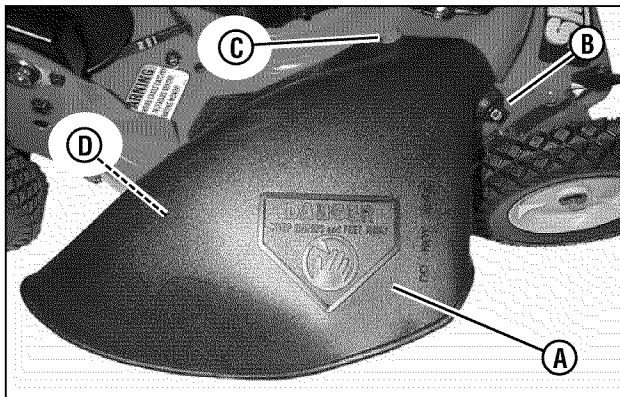

Figure 10: Installing the discharge deflector

Installing the Grass Bag Adapter

(Optional Accessory on Some Models)

1. Remove the recycling cover. Refer to the Section entitled "Recycling Operation".
2. Install the adapter (**A, Figure 11**) to the deck in place of the recycling cover, making sure that:
 - The front hole (**B**) on the outside front of the adapter fits over the stud where the front of the recycling cover was originally secured
 - The slot (**C**) on top of the adapter slips under the restraining nut on top of the deck (under the right front corner of the engine)
 - The slot (**D**) on the rear of the adapter slips onto the stud behind the rear of the discharge opening, where the rear of the recycling cover was originally secured.
3. Install the nuts onto the studs and tighten securely.

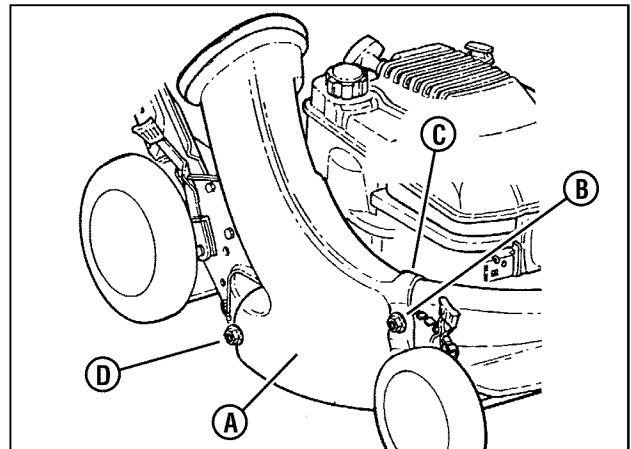

Figure 11: Installing the grass bag adapter

4. (Kawasaki engines only) Attach the grass bag adapter standoff (**A, Figure 12**) between the rope guide pulley and the engine recoil:
 - Remove the right rear bolt (**B**) from the engine recoil.
 - Remove the torx screw and nut securing the rope guide pulley (**C**) to the bracket on the bag adapter.
 - Lay the standoff between the bolt holes in the engine recoil and the bag adapter pulley bracket. (Position the standoff so that the bent end (**D**) is toward the engine recoil cover.)

Operation (Continued)



WARNING



DO NOT attempt any maintenance, adjustments or service with engine and blade running. STOP engine and blade. Disconnect spark plug wire and secure away from spark plug. Engine and components are HOT. Avoid serious burns, allow sufficient time for all components to cool.

Installing the Grass Bag Adapter (Continued)

- Flip the pulley over so that the bushing flange is under the pulley. The bushing will act as a washer between the pulley and the standoff.
- Reassemble the pulley to the bag adapter, and install the supplied replacement bolt, fitted with the thread sleeve, into the recoil cover. Tighten all hardware securely.

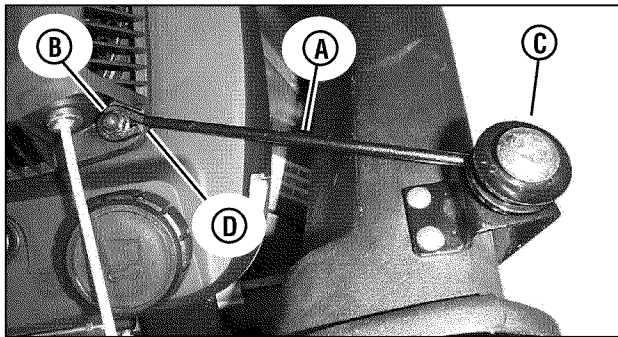

Figure 12: Installing the adapter standoff

5. Route the recoil rope around the outside of the rope guide pulley (C, Figure 12).

Note: The recoil rope may need to be slackened. Refer to the section entitled “Handle Assembly”.



WARNING



DO NOT operate without entire Grass Catcher or guard in place. Grass Catcher components are subject to deterioration during normal use. Inspect frequently and replace worn or damaged components immediately.

Installing the Recycling Plug

1. Install the recycling plug (A, Figure 13) if recycling is desired after the bag adapter is installed. Install the recycling plug completely and securely into the bag adapter (B).

IMPORTANT: Install the grass bag as a safeguard.

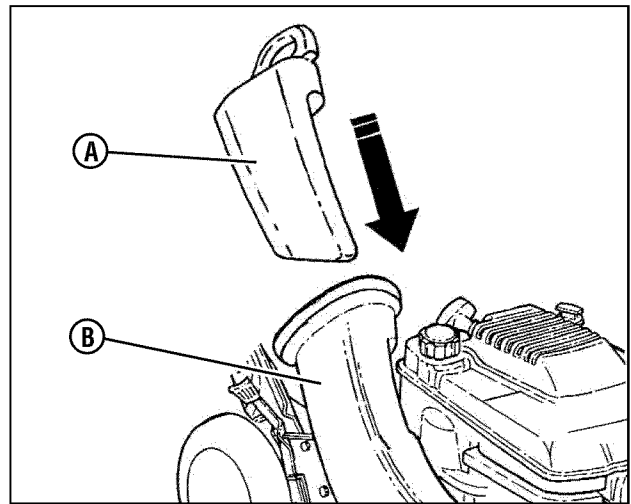

Figure 13: Installing the recycling plug

2. Refer to the section entitled “Recycling Operation”.

Operation (Continued)



WARNING



DO NOT attempt any maintenance, adjustments or service with engine and blade running. STOP engine and blade. Disconnect spark plug wire and secure away from spark plug. Engine and components are HOT. Avoid serious burns, allow sufficient time for all components to cool.

Installing the Grass Bag

(Slide Closure Type)

1. Install the grass bag adapter. Refer to the Section entitled "Installing the Grass Bag Adapter".
2. Install the grass bag by sliding the connector **(A, Figure 14)** over the adapter flange.
3. Attach the grass bag hooks **(B)** over the middle handle cross bar.

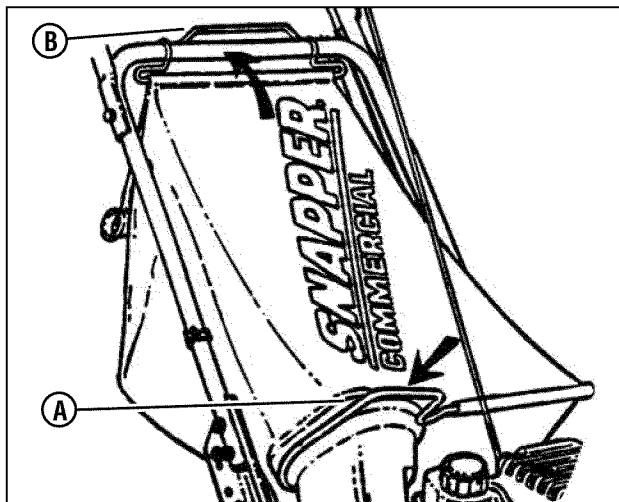

Figure 14: Installing the grass bag

Dumping the Grass Bag

1. Grasp the bag connector and bag handle. Lift up on the bag handle, removing it from the mower handle. Then lift up on the bag connector, removing it from the adapter flange.
2. Open the bag by pulling the bag slider **(A, Figure 15)** off of the Z-fold at the rear of the bag **(B)**.
3. To close the bag, fold the rear of the bag into the former Z-shape, keeping the edges aligned. Grasp the edge of the Z-fold, and while holding the slider, pull the Z-fold fully into the slider.

NOTE: An illustration of the Z-Fold is attached to the bag.

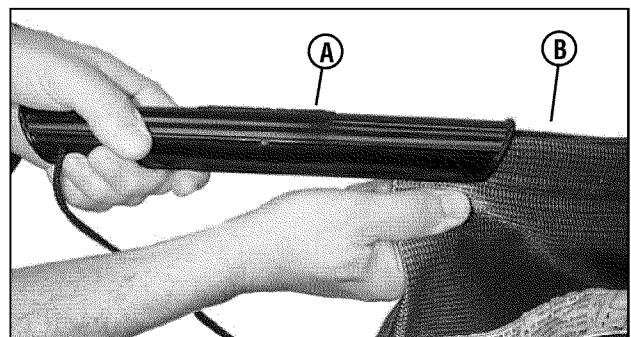

Figure 15: Removing the bag slider



WARNING



Grass Catcher bags used on SNAPPER products are made of woven fabric, and are subject to deterioration and wear during normal usage. Check condition of bag before each use. Immediately replace worn or damaged catcher bags with only bags recommended by SNAPPER. The grass catcher is optional equipment on some models.

Maintenance

Maintenance - Introduction

To retain the quality of the mower, use genuine SNAPPER replacement parts only. Contact a local SNAPPER dealer for parts and service assistance. For the correct part or information for a particular mower, always mention the model and serial number.



WARNING



DO NOT attempt any maintenance, adjustments or service with engine and blade running. STOP engine and blade. Disconnect spark plug wire and secure away from spark plug. Engine and components are HOT. Avoid serious burns, allow sufficient time for all components to cool. Wear heavy leather gloves when handling or working around cutting blades. Blades are extremely sharp and can cause severe injury.

Service - After First 5 Hours

Change Engine Oil

1. Refer to the Engine Manual for proper oil specifications, procedures and proper service intervals.
2. For the simplest/cleanest oil change, simply turn the mower on its side to drain the oil, as shown. Drain the oil through the dipstick tube (A, Figure 16) into a container. Allow sufficient time for all the oil to drain.

Important: Drain the fuel tank before tipping the machine. DO NOT tip the machine with the carburetor or spark plug down. Oil from the crankcase will saturate the air filter and cause the engine to be hard to start or not start at all. If contamination does occur, the air filter will have to be replaced.

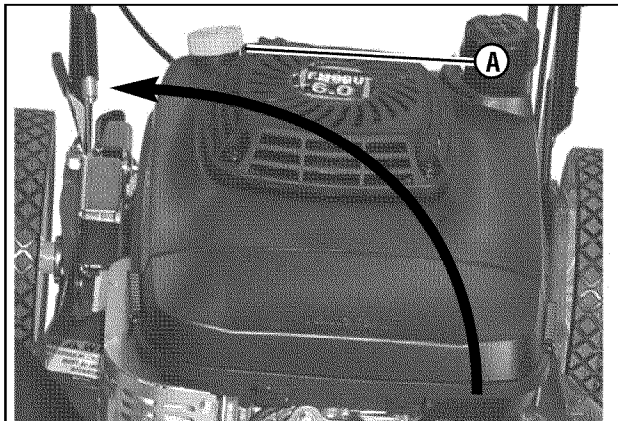

Figure 16: Draining the engine oil

3. Dispose of drain oil properly.
4. Fill the engine with oil as specified in the Engine Manual. Do not overfill.

Check Grease Level in Transmission

1. Remove the transmission fill plug (A, Figure 17). Roll the machine forward or backward while looking down into the plug hole.
2. If liquid grease is not visible on the input gear (the small gear below the plug hole), add an amount, to cover the gear, of Snapper "00" grease.

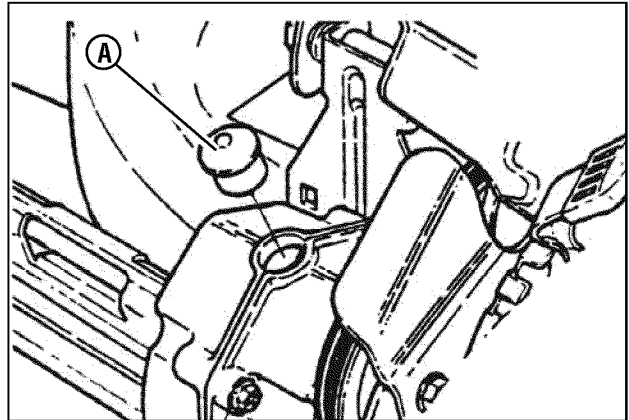

Figure 17: Removing the transmission fill plug

Note: Snapper "00" grease (Part No. 7029443) is available at your Snapper dealer.

Note: Do not spill grease or oil onto the surface of the drive disc (A, Figure 18).

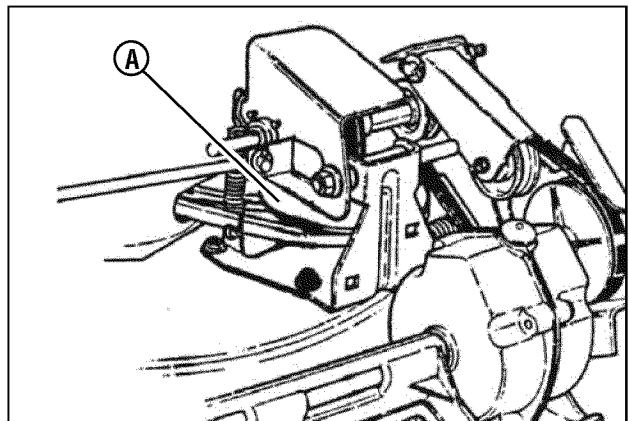

Figure 18: Location of the drive disc

3. Reinstall the transmission plug.
4. Check the grease level after each 25 hours of operation.

Important: Drain the fuel tank before tipping the mower. DO NOT tip the machine with the carburetor or spark plug down. Oil from the crankcase will saturate the air filter and cause the engine to be hard to start or not start at all. If contamination does occur, the air filter will have to be replaced.

Maintenance (Continued)



WARNING



DO NOT attempt any maintenance, adjustments or service with engine and blade running. STOP engine and blade. Disconnect spark plug wire and secure away from spark plug. Engine and components are HOT. Avoid serious burns, allow sufficient time for all components to cool. Wear heavy leather gloves when handling or working around cutting blades. Blades are extremely sharp and can cause severe injury.

Check Mower Blade

1. Disconnect the spark plug wire and secure the end away from the plug.
2. Tilt the mower up on its rear wheels for access to the blade cap screw (**A, Figure 19**). Do not tilt the mower with the spark plug or carburetor down.

Important: Drain the fuel tank before tipping the mower. DO NOT tip the machine with the carburetor or spark plug down. Oil from the crankcase will saturate the air filter and cause the engine to be hard to start or not start at all. If contamination does occur, the air filter will have to be replaced.

3. Check the torque of the blade cap screw. Recommended torque should be 40 ft. lbs.
4. Check the blade for sharpness, wear and damage. Refer to the Section entitled “Blade Wear Limits”.

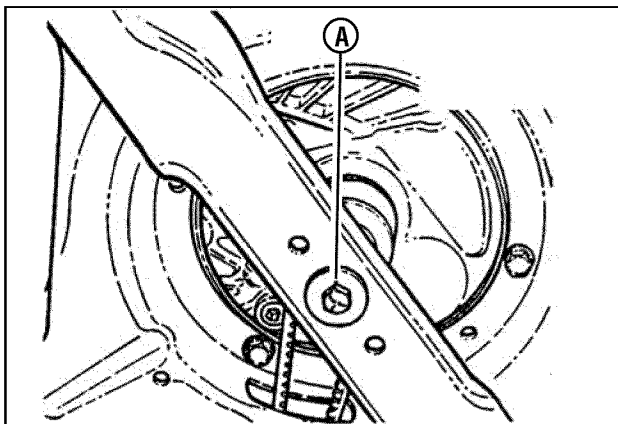

Figure 19: Tightening the blade cap screw

Check Engine Drive Belt

1. Visually check the engine drive belt for cracking, fraying, severed or exposed belt strands. If worn or damaged, replace the belt before operating the mower.

Check Transmission Poly-V Belt

1. Visually check the poly-v belt for cracking, fraying, severed or exposed belt strands. If worn or damaged, replace the belt before operating the mower.

Service - Periodic

Perform all maintenance as described in the “Service Schedule” section of this manual.

Engine

Service the engine according to the engine owner’s manual.

Air Filter

Refer to the engine owner’s manual for service instructions.

Engine Oil

Refer to the engine owner’s manual for service instructions.

Storage Procedure

Refer to the Engine Owner’s Manual for directions regarding engine storage preparations. Prepare the mower for “end of season” storage as follows:

1. Drain the fuel from the fuel tank and let the engine run until all fuel is out of the carburetor.
2. Disconnect and remove the spark plug wire away from the spark plug before any other preparations are made!
3. Tape all openings closed to prevent spraying water into the exhaust or air intakes during washing.
4. Tilt the mower up on its rear wheels and thoroughly clean the underside of the deck. Do not tilt the mower with the spark plug or carburetor down. Scrape away any accumulation of grass with a putty knife and/or wire brush.
5. Lubricate all exposed metal with a light coating of oil to prevent corrosion.
6. On self-propelled models, disconnect the transfer rod clip and remove the ground speed control rod before folding the handles.
7. Loosen the handle knobs. Carefully fold the handles forward, “flexing” the control cables to prevent cable damage.
8. Store the mower in a shed or other dry area, protected from weather.

Maintenance (Continued)



WARNING



DO NOT attempt any maintenance, adjustments or service with engine and blade running. STOP engine and blade. Disconnect spark plug wire and secure away from spark plug. Engine and components are HOT. Avoid serious burns, allow sufficient time for all components to cool. Wear heavy leather gloves when handling or working around cutting blades. Blades are extremely sharp and can cause severe injury.

Mower Blade Replacement

Standard Blade Wear Limit

1. Inspect the blade (**Figure 20**) frequently for signs of excessive wear or damage:
 - (A) New blade
 - (B) Wear limit (notch starts)
 - (C) Dangerous condition! Do not use on the mower! Replace with a new blade.

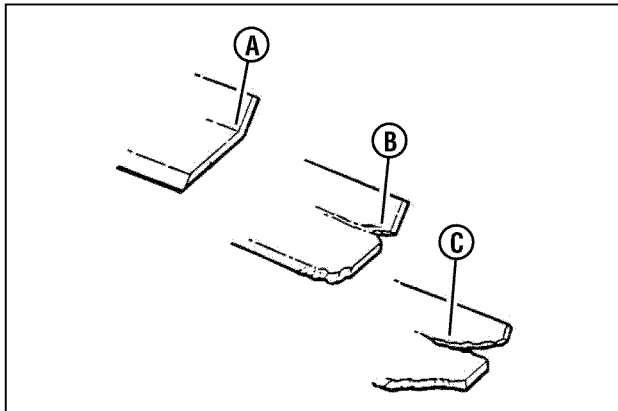

Figure 20: Standard blade wear limits

Ninja Blade Wear Limit

1. Inspect the blade (**Figure 21**) frequently for signs of excessive wear or damage:
 - (A) New blade
 - (B) Wear limit (cracks or notches begin to appear on tip)
 - (C) Dangerous condition! Do not use on the mower! Replace with a new blade.



WARNING



DO NOT use a cutting blade that shows signs of excessive wear or damage. Refer to the Section entitled "MOWER BLADE REPLACEMENT" for proper blade inspection and service procedures.

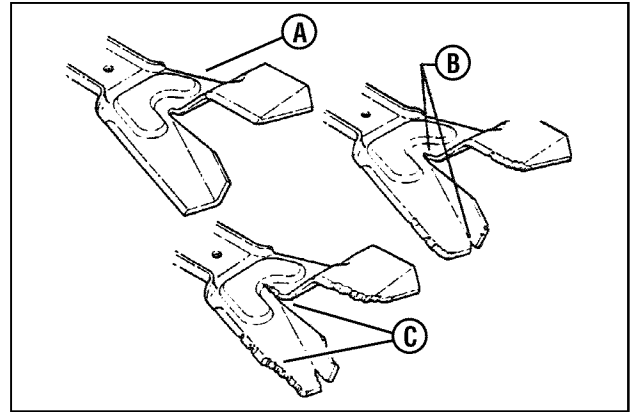

Figure 21: Ninja blade wear limits

Blade Sharpening

1. Disconnect the spark plug wire and secure the end away from the plug.
2. Tilt the mower up on its rear wheels. Do not tilt the mower with the spark plug or carburetor down.

Important: Drain the fuel tank before tipping the mower. DO NOT tip the machine with the carburetor or spark plug down. Oil from the crankcase will saturate the air filter and cause the engine to be hard to start or not start at all. If contamination does occur, the air filter will have to be replaced.

3. Remove the blade (**B, Figure 22**).

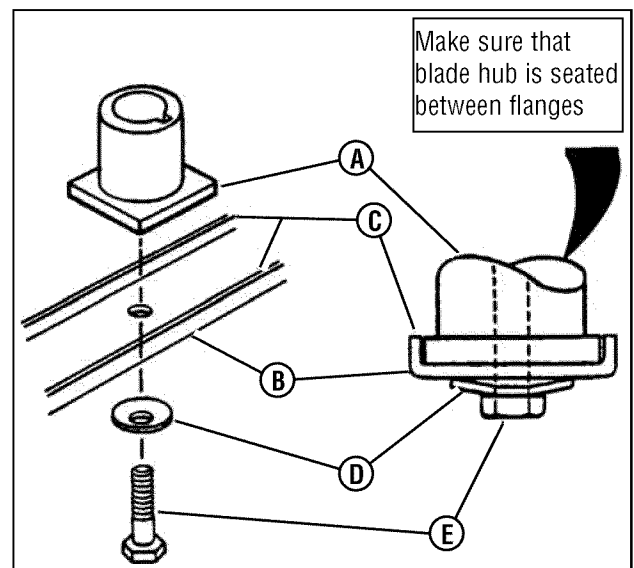

Figure 22: Removing the mower blade

Maintenance (Continued)



WARNING



DO NOT attempt any maintenance, adjustments or service with engine and blade running. STOP engine and blade. Disconnect spark plug wire and secure away from spark plug. Engine and components are HOT. Avoid serious burns, allow sufficient time for all components to cool.

Blade Sharpening (Continued)

- Sharpen the blade on a grinding wheel at an angle of 22 to 28 degrees (**B, Figure 23**). DO NOT sharpen the blade beyond the original cutting edge (**A**).

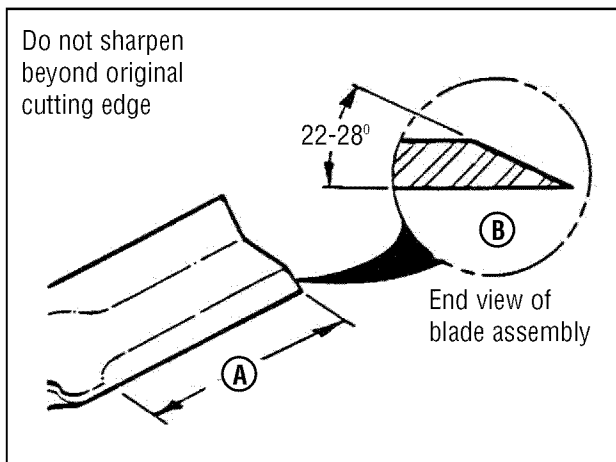

Figure 23: Sharpening the mower blade

- Check blade for balance. If necessary, correct balance by grinding heavy end of blade.
- Reinstall blade (**B, Figure 22**). Note the correct assembly order:
 - Blade hub
 - Blade
 - Blade flange (facing up)
 - Cone washer (concave side up)
 - Capscrew
- Check torque of blade retaining cap screw. Recommended torque should be 40 ft. lbs.

Wheel Drive Control Adjustment (Self-Propelled Models Only)

- The wheel drive control is properly adjusted when there is 1/16" to 1/8" clearance (**G, Figure 24**) between the inside of the spring hook (**E**) and the inside of the clutch cable eye (**C**) with the wheel drive control released.

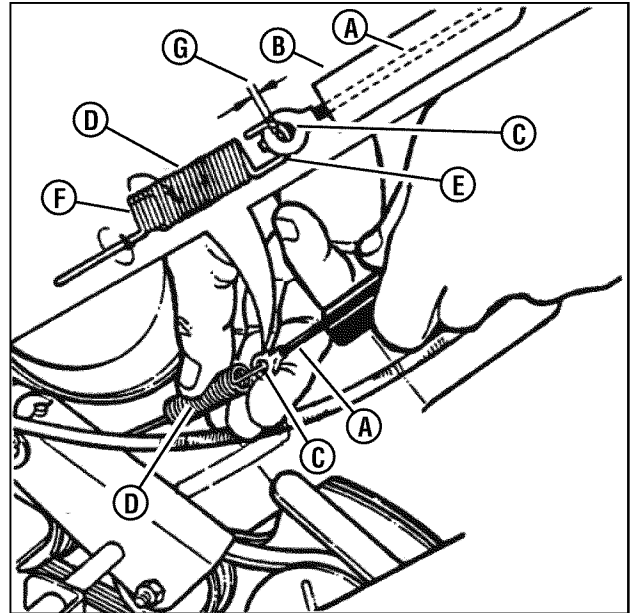

Figure 24: Wheel drive control adjustment

- To adjust, unhook the upper spring (**D**) from the cable eye and rotate the spring in the direction required to extend or shorten the spring length.
- Rehook the upper spring to the cable eye and check clearance. Repeat the procedure if required.

*Note: The vinyl spring cover (**B**) should be kept over the spring at all times except for adjustments.*

- If the wheel drive control fails to return quickly to the "OFF" position when released, check for binding at the cable holdings located on the side of the right handle. The upper clip should be located 2" below the upper knob; the lower clip should be 4" above the lower knob. The cable should slide freely with the clips installed at these locations.

Maintenance (Continued)



WARNING



DO NOT attempt any maintenance, adjustments or service with engine and blade running. STOP engine and blade. Disconnect spark plug wire and secure away from spark plug. Engine and components are HOT. Avoid serious burns, allow sufficient time for all components to cool.

Driven and Drive Disc Service

If the mower does not propel itself properly, check for the following problems:

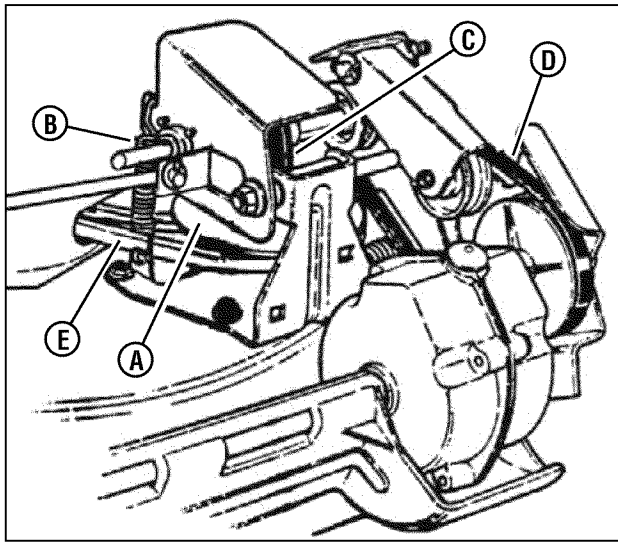

Figure 25: Wheel drive components

1. Grease on the drive disc (**A, Figure 25**) causing slippage.
2. Broken or disconnected drive spring (**B**).
3. Driven disc (**C**) is out of adjustment.
4. Driven disc rubber is worn - does not contact drive disc properly.
5. Worn Poly-V belt (**D**) or engine drive belt (**E**).

If any of the above (1 thru 5) are causing problems, service as follows:

Cleaning Drive Disc & Driven Disc

If oil or grease on the drive disc or driven disc is causing slippage, clean the discs as follows:

1. Wipe away any oil or grease with a clean cloth.
2. Use either an approved grease solvent or hot, soapy water to clean drive disc or driven disc.
3. Rinse components with clean water.
4. Dry components with a clean cloth.

Drive Spring Repair/Replacement

If the drive spring (**A, Figure 26**) is loose, reconnect. If the spring is broken, replace with a new spring.

Note: Use a pair of needle nose pliers to install the drive spring.

IMPORTANT: If the drive system continues slipping, refer to the Troubleshooting section.

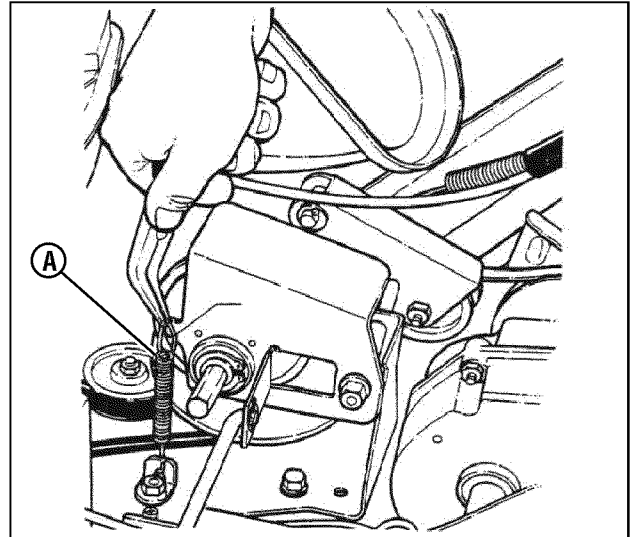

Figure 26: Replacing the drive spring

Driven Disc Adjustment

If the drive disc and driven disc are clean and the mower drive is still slipping, adjust the driven disc as follows:

1. Move the ground speed control (**A, Figure 27**) into the 'fast' position.

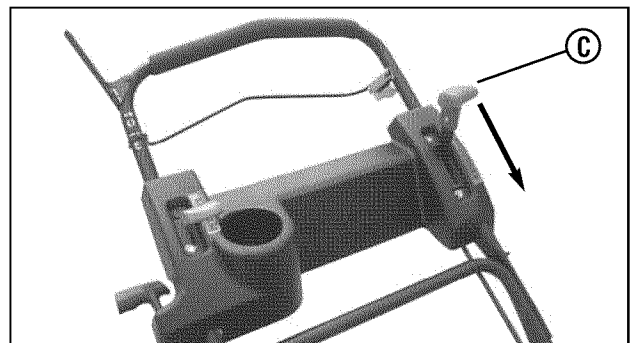

Figure 27: The ground speed control

Maintenance (Continued)



WARNING



DO NOT attempt any maintenance, adjustments or service with engine and blade running. STOP engine and blade. Disconnect spark plug wire and secure away from spark plug. Engine and components are HOT. Avoid serious burns, allow sufficient time for all components to cool.

Driven Disc Adjustment (Continued)

2. Remove the driven disc spring (A, Figure 28) from the driven disc assembly (B). Also remove the pin and washer (C) from the transfer rod (D), and remove the end of the transfer rod from the hole in the driven disc assembly.

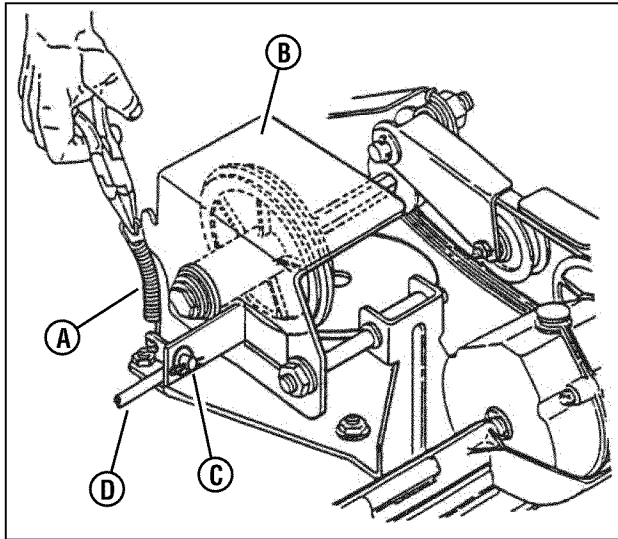

Figure 28: Adjusting the driven disc

3. Slide the driven disc assembly over to 1/8" (A, Figure 29) from the outside edge of the drive disc (B).
4. Loosen the jam nut (A, Figure 30) securing the transfer rod (B) to the ball joint (C) on the pivot bracket (D).
5. Turn the rod in or out of the ball joint until the end of the rod aligns with the hole (E) in the driven disc assembly from which the rod was removed.

IMPORTANT: Do not move the pivot bracket.

6. Reinstall the rod as removed in Step 2. Move the ground speed control to the 'slow' position, then back to the 'fast' position. Recheck the 1/8" measurement described previously. Readjust as needed. Tighten the nut when finished.
7. Reinstall the driven disc spring to the driven disc assembly.

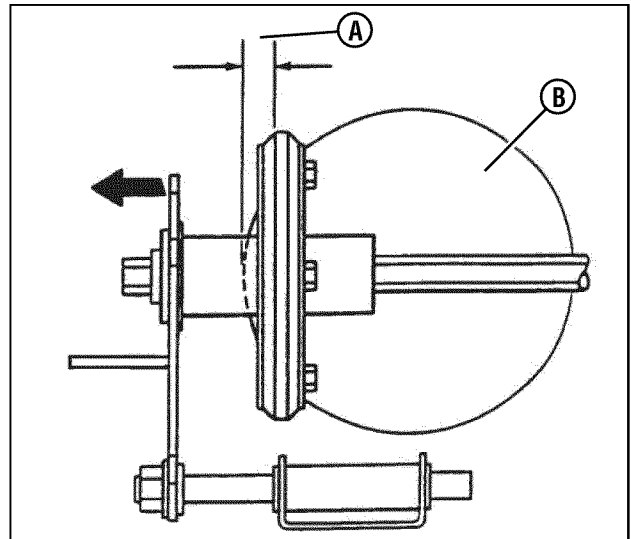

Figure 29: Proper driven disc adjustment

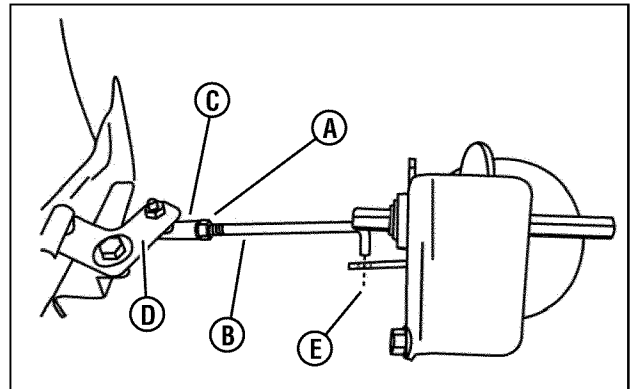

Figure 30: Adjusting the transfer rod

Driven Disc Ring Replacement

If the rubber ring on the driven disc is badly chunked or worn, it must be replaced. Install a new driven disc ring as follows:

1. Remove the pin and washer (C, Figure 28) from the transfer rod (D), and remove the end of the transfer rod from the hole in the driven disc assembly.

Maintenance (Continued)



WARNING



DO NOT attempt any maintenance, adjustments or service with engine and blade running. STOP engine and blade. Disconnect spark plug wire and secure away from spark plug. Engine and components are HOT. Avoid serious burns, allow sufficient time for all components to cool.

Driven Disc Ring Replacement (Continued)

- Using needle nose pliers, unhook the drive spring (A, Figure 31) and slide the driven disc assembly off the hex shaft.
- Remove the five machine screws (A, Figure 32) and plate (B) which secure the rubber ring (C) to the driven disc hub (D).
- Install a new rubber ring.
- Reverse the above procedures for reassembly and installation of the driven disc assembly.

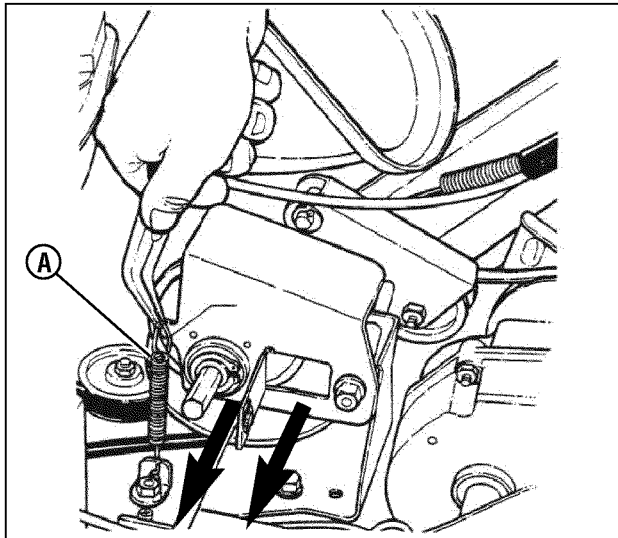

Figure 31: Removing the driven disc assembly

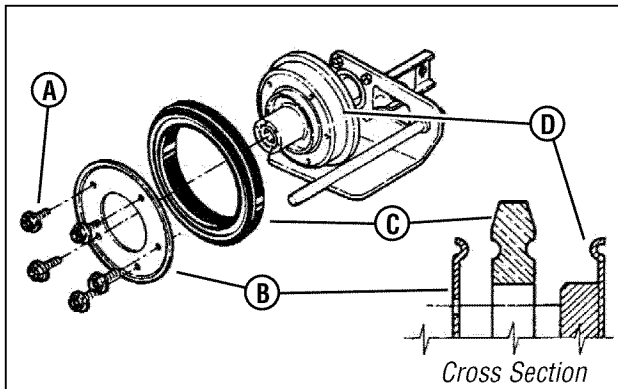

Figure 32: Replacing the driven disc rubber ring

Driven Disc Bearing Replacement

If the driven disc bearing requires replacement, replace the bearing as follows:

- Remove the driven disc assembly. Refer to the Section entitled "Driven Disc Replacement".
- Remove the snap ring (A, Figure 33) that secures the driven disc hub (B) to the thrust plate.
- Slide the driven disc hub out of the bearing (C).
- Remove the four screws, and replace the bearing.
- Reassemble the components in reverse order.

NOTE: Be sure to replace the shim washer (D) when reassembling the driven disc assembly.

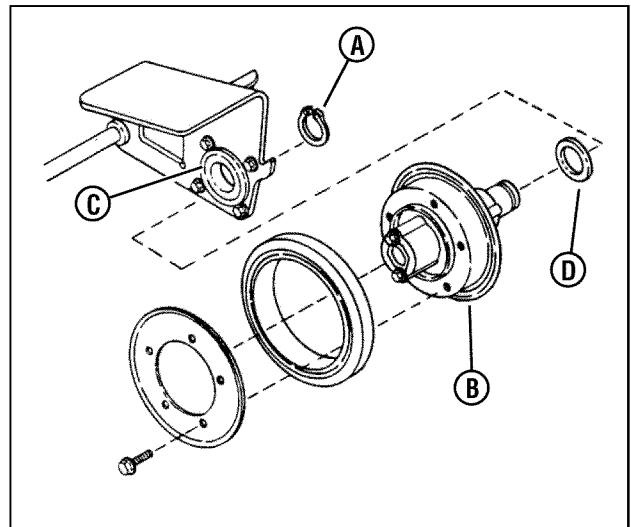

Figure 33: Replacing the driven disc bearing

Maintenance (Continued)



WARNING



DO NOT attempt any maintenance, adjustments or service with engine and blade running. STOP engine and blade. Disconnect spark plug wire and secure away from spark plug. Engine and components are HOT. Avoid serious burns, allow sufficient time for all components to cool.

Replacing the Bearing On the Pulley End Of the Hex Shaft

To replace the bearing on the pulley end of the hex shaft, proceed as follows:

1. Hold the hex shaft with an adjustable wrench held next to the pulley.
2. Remove the 3/8" hex lock nut (**B**, **Figure 34**), located on the outside of the right wheel bracket.
3. Remove the holder (**A**), O-ring (**C**) and bearing (**D**).
4. Install the new bearing.
5. Carefully install the new O-ring over the outside of the new bearing.
6. Install the bearing holder, and secure with screws.
7. Install the 3/8" hex lock nut.

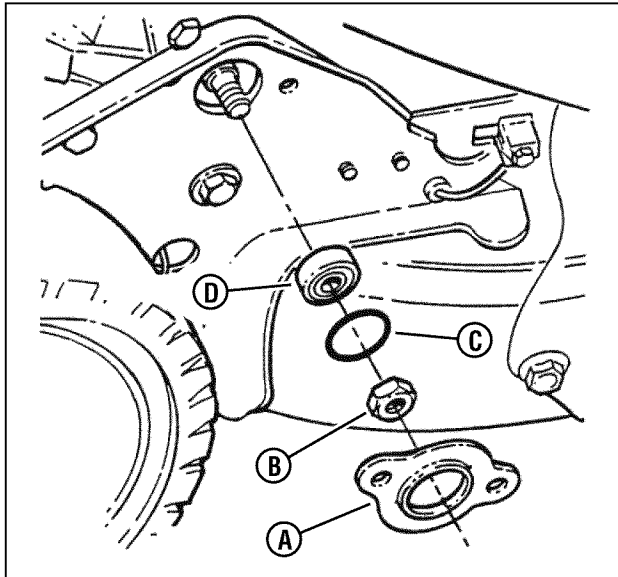

Figure 34: Replacing the hex shaft bearing

Belt Service

On self-propelled mowers, the engine belt (**A**, **Figure 35**) transmits power from the engine pulley (**B**) to the drive disc (**C**). The drive disc powers the poly-v belt, which engages the transmission that powers the rear wheels. Should these belts become worn, they could cause slippage, which would impair mower performance. The condition of the engine belt and poly-v belt should be checked after every 25 hours of mower operation.

Engine Drive Belt Replacement (Stretch Type Belts)

1. Empty the fuel tank.
2. Note the belt routing (**Figure 35**). There is no idler pulley on these models to disconnect.

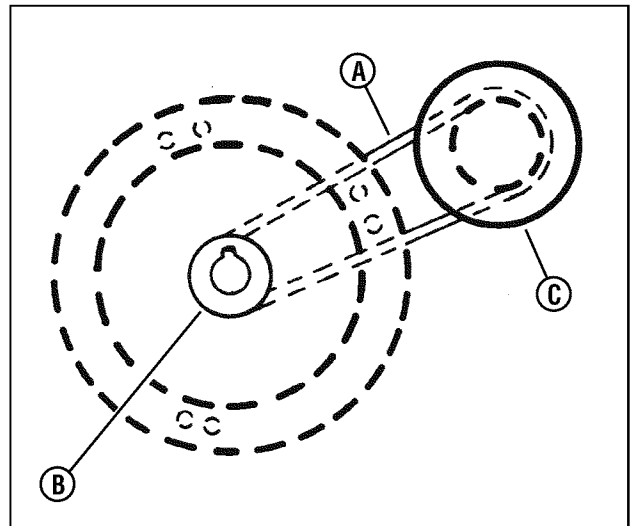

Figure 35: Engine drive belt routing

Maintenance (Continued)



WARNING



DO NOT attempt any maintenance, adjustments or service with engine and blade running. STOP engine and blade. Disconnect spark plug wire and secure away from spark plug. Engine and components are HOT. Avoid serious burns, allow sufficient time for all components to cool.

Engine Drive Belt Replacement (Stretch Type Belts - Continued)

IMPORTANT: Drain the fuel tank before tipping the mower. DO NOT tip the machine with the carburetor or spark plug down. Oil from the crankcase will saturate the air filter and cause the engine to be hard to start or not start at all. If contamination does occur, the air filter will have to be replaced.

3. Remove the driven disc. Refer to the Section entitled "Driven Disc Replacement" for driven disc removal procedure.
4. Drain the fuel tank before tipping the mower. Do not tilt the mower with the spark plug or carburetor down. Tilt the mower up on its rear wheels and remove the blade and blade hub. Assistance from another person may be necessary to hold the mower in the tilted position.
5. Hold the slotted end of the drive disc bolt (**B**, **Figure 36**) with a screwdriver and remove the nut (**G**) and internal tooth lock washer (**F**).
6. Remove the belt cover, located under the deck.
7. Lift the drive disc (**A**) up and remove the worn belt.
8. Loop one end of the new belt over the engine pulley and insert the other end through the slot in the deck.
9. Loop the belt around the pulley on the bottom of the drive disc.
10. Reinstall the drive disc and retaining hardware.

IMPORTANT: 1) The square shoulder of the drive disc bolt must fit into the square hole of the bushing. 2) The square end of bushing must fit into the bracket slot.

11. Reinstall the belt cover and tighten the bolts securely.
12. Reinstall the blade hub and cutter blade. Recommended torque for the blade cap screw is 40 ft. lbs.

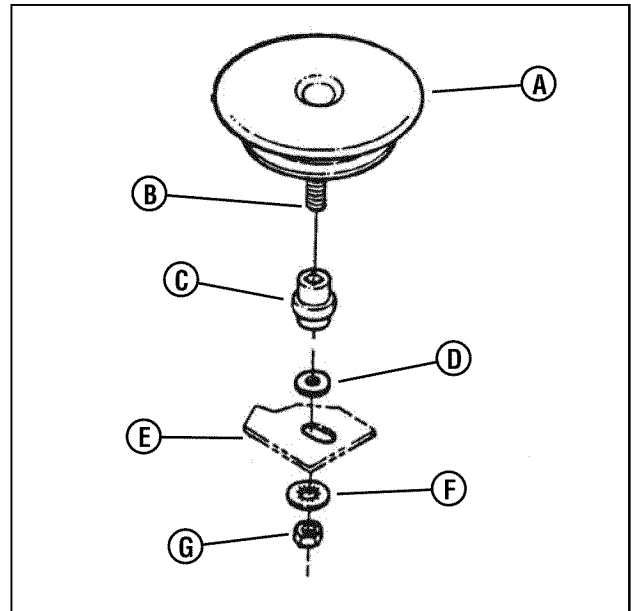

Figure 36: Removing the drive disc

Transmission Poly-V Belt Replacement

1. Remove the driven disc. Refer to the Section entitled "Replacing Driven Disc Rubber Ring".
2. Note the routing of the old belt around the three pulleys before removing it.
3. Place the new Poly-V Belt (**A**, **Figure 37**) over the end of the hex shaft (**B**) and onto the drive pulley (**C**).
4. Work the belt onto the top of the idler pulley (**D**).
5. Twist the belt sideways and pull it upward between the differential bracket (**E**) and driven pulley (**F**) and then down into the pulley groove. Make sure the Poly-V Belt is above the belt guide (**G**).

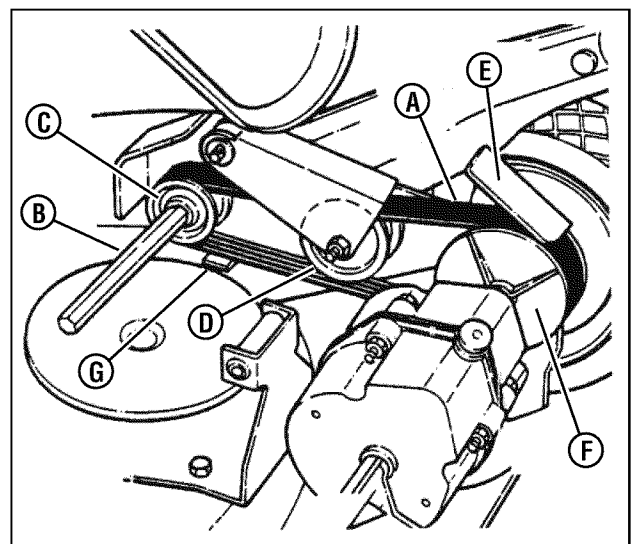

Figure 37: Poly-v belt routing

Service Schedule

ITEM	SERVICE PERFORMED	REF.	EACH USE	5 HRS	25 HRS	50 HRS	100 HRS	EACH SEASON
Engine Oil	Check Oil Level	Page 5	X					
	Initial Oil Change	Page 11		X				
	Periodic Oil Change	Page 12			X*			
Air Pre-Cleaner	Clean Sponge Element	Engine Manual			X**			
Air Cleaner	Clean or Replace	Engine Manual			X**			
Spark Plug	Replace	Engine Manual					X	
Engine Cooling System	Clean Shroud & Fins	Engine Manual					X**	
Drive Belts	Check for Wear and Tension	Page 12, 18			X	X		X
Mower Blade	Check for wear, Damage & Replacement	Page 13	X					
Mower Deck	Clean Debris Accumulation	Page 5	X					
Transmission Grease	Check Grease Level	Page 11			X			X
	Periodic Grease Check	Page 11						X
Drive Disc	Check for Wear Damage and Replacement	Page 14-17				X		

* Change oil every 25 hours when operating under heavy load or high temperatures.

** Clean more often under dusty conditions or when air debris is present.

Maintenance

Maintenance/Replacement Parts

Engine Speed Control (Kawasaki)	7074138
Engine Speed Control (Honda)	7078026
Blade Control Cable (Kawasaki)	7074141
Blade Control Cable (Honda)	7029344
Clutch Pull Cable	7034604
Cutter Blade (Air Lift Compatible)	7019795
Cutter Blade (Mulching)	7017168
Cutter Blade (Not Air Lift Compatible)	7026691
Cutter Blade (Ninja - Quad Edge)	7026407
Wheel Drive Pulley to Transmission Pulley Belt	7012354
Engine to Drive Disc Belt	7046784
Cantilever Drive Tire Assembly	7073528
Rubber Drive Tire	7010927
Parts Manual for 21" Steel Deck Commercial Walk Behind Mower Series 19 - Recycling ('R') Models	7006156
Parts Manual for 21" Steel Deck Commercial Walk Behind Mower Series 19	7006155

Troubleshooting

PROBLEM	PROBABLE CAUSE	CORRECTIVE ACTION
Engine Will Not Start Using Recoil Starter	1. Fuel tank empty.	1. Fill fuel tank with fresh fuel.
	2. Engine needs choking.	2. Choke engine. Check Engine Manual for Instructions.
	3. Spark plug wire disconnected.	3. Place spark plug wire onto spark plug.
	4. Fuel shut-off in the 'Off' position.	4. Turn Fuel shut-off to 'On' position.
Engine Stalls or Stops After Running	1. Blade control is released or is not being held securely against handle.	1. Blade control should be held securely against handle at all times during operation of mower.
	2. Engine speed control in 'Choke' position.	2. Turn off choke.
	3. Fuel tank empty.	3. Fill with fuel to proper level.
	4. Engine air pre-cleaner and or air cleaner dirty.	4. Clean free of all debris.
	5. Spark plug defective or gap set improperly.	5. Service spark plug.
	6. Water, debris or stale fuel in fuel system.	6. Drain and clean fuel system.
	7. Fuel shut-off in the 'Off' position.	7. Turn Fuel shut-off to 'On' position.
Engine Loses Power	1. Engine air pre-cleaner or air cleaner dirty.	1. Clean or replace filters.
	2. Spark plug faulty.	2. Service spark plug.
	3. Water, debris or stale fuel in fuel system.	3. Drain and clean fuel system.
Excessive Vibration	1. Damaged, out of balance or bent mower blade.	1. Service mower blade.
	2. Loose blade components.	2. Service and tighten loose parts.
	3. Loose or missing air lift (if equipped).	3. Replace air lifts. Tighten to proper torque.
	4. Lumpy or frayed belt.	4. Replace belt.
Mower Will Not Move Loss Of Traction	1. Build-up of debris on or around wheel drive components.	1. Clean debris.
	2. Driven disc slipping.	2. Clean or replace driven disc.
	3. Drive belt requires replacement.	3. Replace drive belt.
	4. Damaged transmission.	4. Contact authorized SNAPPER dealer.
Cutting Grass Improperly	1. Cutting height too low or high.	1. Adjust cutting height.
	2. Engine speed too slow.	2. Move engine speed control to 'Fast' position.
	3. Forward ground speed too fast.	3. Move ground speed control to a slower speed.
	4. Terraced cut, side to side.	4. Adjust height of cut with height adjust levers.
	5. Excessive deck pitch, front to rear.	5. Adjust height of cut with height adjust levers.
	6. Cutting blade dull or damaged.	6. Sharpen cutting edges or replace blade.
Poor Grass Discharge	1. Engine speed too fast.	1. Move engine speed control to 'Fast' position.
	2. Forward speed too fast.	2. Move ground speed control to a slower speed.
	3. Grass is wet.	3. Mow when grass is dry.
	4. Excessively worn or damaged blade.	4. Service mower blade.
	5. Build up of grass clippings and debris under deck.	5. Clean deck.
	6. Improper blade installed on deck.	6. Install proper SNAPPER blade.
	7. Blade installed improperly on deck.	7. Install blade properly.
Oil Leaking	1. Leaking engine case.	1. Contact authorized SNAPPER dealer.
		2. Check and tighten drain plug.
		3. Make sure dip stick or oil filler cap is securely in place.

SNAPPER®

2 YEAR LIMITED WARRANTY

For two (2) years from purchase date for the original purchaser's residential, non-commercial use, SNAPPER, through any authorized SNAPPER dealer will replace, free of charge (except for taxes where applicable), any part or parts found upon examination by the factory at McDonough, Georgia, to be defective in material or workmanship or both.

For ninety (90) days from purchase date for the original purchaser's commercial, rental, or other non-residential use, SNAPPER, through any authorized SNAPPER dealer will replace, free of charge, any part or parts found upon examination by the factory at McDonough, Georgia, to be defective in material or workmanship or both.

All transportation costs incurred by the purchaser in submitting material to an authorized SNAPPER dealer for replacement under this warranty must be paid by the purchaser.

This warranty does not apply to certain transmissions, to engines and their components, and batteries, as these items are warranted separately. This warranty does not apply to parts that have been damaged by accident, alteration, abuse, improper lubrication, normal wear, or other cause beyond the control of SNAPPER. This warranty does not cover any machine or component part that has been altered or modified changing safety, performance, or durability.

Batteries have a one (1) year warranty period with free replacement if required for one (1) year from the original purchase date. SNAPPER will not be responsible for any installation cost incurred. The battery warranty only covers original equipment batteries and does not cover damage to the battery or machine caused by neglect or abuse, destruction by fire, explosion, freezing, overcharging, improper maintenance, or use of improper electrolyte.

There is no other express warranty.

DISCLAIMER OF WARRANTY

Implied warranties, including those of merchantability and fitness for a particular purpose, are limited to two (2) years from purchase date for the original purchaser's residential or other non-commercial use, and ninety (90) days from purchase for the original purchaser's commercial, rental or other non-residential use, and to the extent permitted by law, any and all implied warranties are excluded. This is the exclusive remedy. Liabilities for consequential damages, under any and all warranties are excluded.

Some states do not allow limitations on how long an implied warranty lasts, or do not allow the exclusion or limitation of incidental or consequential damages, so the above limitation or exclusion may not apply to you.

This warranty gives you specific legal rights, and you may also have other rights which vary from state to state.

WARNING: THE USE OF REPLACEMENT PARTS OTHER THAN GENUINE SNAPPER PARTS MAY IMPAIR THE SAFETY OF SNAPPER PRODUCTS AND WILL VOID ANY LIABILITY AND WARRANTY BY SNAPPER ASSOCIATED WITH THE USE OF SUCH PARTS.

IMPORTANT: Please fill out the attached SNAPPER Product Registration Card immediately and mail to:
Snapper's Product Registration Center, P.O. Box 1379, McDonough, Georgia 30253

SLOPE GUIDE

SIGHT AND HOLD THIS GUIDE LEVEL WITH A VERTICAL TREE, A CORNER OF A STRUCTURE, A POWER LINE POLE, OR A FENCE.

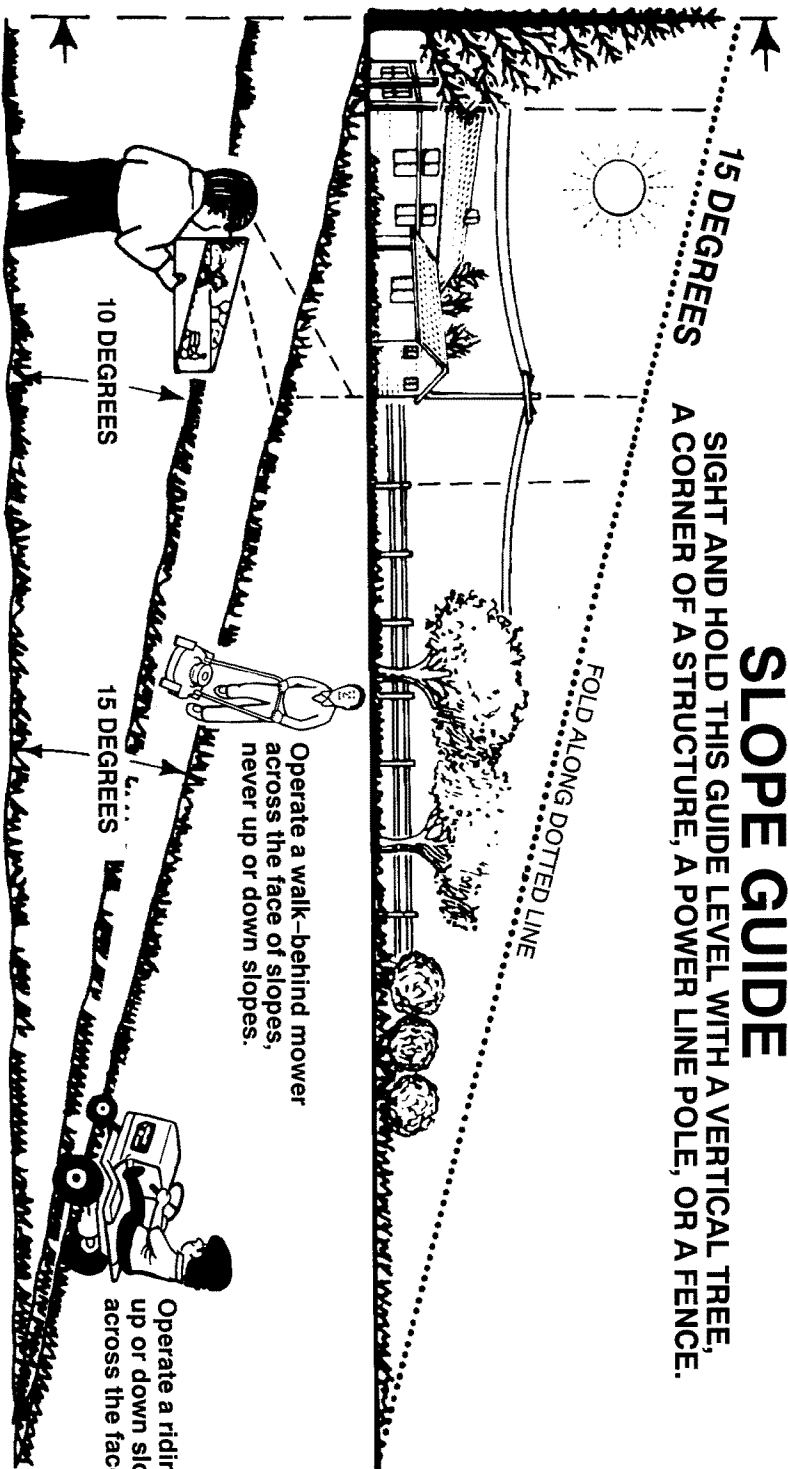

On a riding mower to determine if a slope is safe to mow: (1) disengage the blade(s), (2) put the unit in reverse, and (3) try to back straight up the slope. If you can back up the slope, it is generally safe to mow. However, if you do not feel safe, or if you are not completely sure, use this guide and do not mow a slope that is greater than 15 degrees. If the riding mower is used with a pull-behind or rear mounted attachment, do not operate the unit on a slope that is greater than 10 degrees.

A 15 degree slope is a hill that increases in height at approximately 2.5 feet in 10 feet.
 A 10 degree slope is a hill that increases in height at approximately 1.7 feet in 10 feet.



Use extreme care at all times, and avoid sudden turns or maneuvers. Follow other instructions in this manual for safety in mowing on slopes. Operate a riding mower up or down slopes, never across the face of slopes. Operate a walk-behind mower across the face of slopes, never up or down slopes. Use extra care when operating on or near slopes and obstructions.

..... CUT HERE TO USE SLOPE GUIDE

SNAPPER®

21" STEEL DECK WALK MOWERS COMMERCIAL MODELS SERIES 19

Product Specifications		Common Service Parts	Part Number
Deck Size	21 in	Cutter Blade (Ninja - Quad)	7026407
Height of Cut	1.25 - 4 in	Cutter Blade (Air Lift Compatible)	7019795
Transmission Type	Gear	Drive Belt (Engine)	7046784
Ground Speed	1 - 4 mph	Drive Belt (Transmission)	7012354
Engine Power (Kawasaki)	6.0 hp (gross)	Parts Manual - Recycling ('R') Models	7006156
Engine Power (Honda)	5.5 hp (gross)	Parts Manual	7006155
Engine Displacement (Kawasaki)	180 cc		
Engine Displacement (Honda)	160 cc		
Fuel Tank Capacity (All)	2.1 qt		

Engine Power Rating Information: The gross power rating for individual gas engine models is labeled in accordance with SAE (Society of Automotive Engineers) code J1940 (Small Engine Power & Torque Rating Procedure), and rating performance has been obtained and corrected in accordance with SAE J1995 (Revision 2002-05). Torque values are derived at 3060 RPM; horsepower values are derived at 3600 RPM. Actual gross engine power will be lower and is affected by, among other things, ambient operating conditions and engine-to-engine variability. Given both the wide array of products on which engines are placed and the variety of environmental issues applicable to operating the equipment, the gas engine will not develop the rated gross power when used in a given piece of power equipment (actual "on-site" or net power). This difference is due to a variety of factors including, but not limited to, accessories (air cleaner, exhaust, charging, cooling, carburetor, fuel pump, etc.), application limitations, ambient operating conditions (temperature, humidity, altitude), and engine-to-engine variability. Due to manufacturing and capacity limitations, Briggs & Stratton may substitute an engine of higher rated power for this Series engine.