

SET-UP INSTRUCTIONS & PRE-OPERATION CHECKLIST

SNAPPER 21" STEEL DECK WALK BEHIND MOWERS

INTRODUCTION: The SNAPPER Walk Behind Mowers are shipped almost fully assembled and require minimal set-up. Complete each of the following steps carefully. Review and complete each item as instructed on the Pre-Operation checklist. The Snapper Product Registration card must be filled out and sent to Customer Service department at Snapper when completed.

WARNING – DO NOT ATTEMPT TO START OR OPERATE THIS UNIT UNTIL ALL ASSEMBLY STEPS HAVE BEEN COMPLETED. SERIOUS INJURY OR EQUIPMENT DAMAGE MAY RESULT.

HANDLE ASSEMBLY

STEP 1: Remove mower from shipping carton. Mower shown as removed from shipping carton with handles folded in Figure 1.

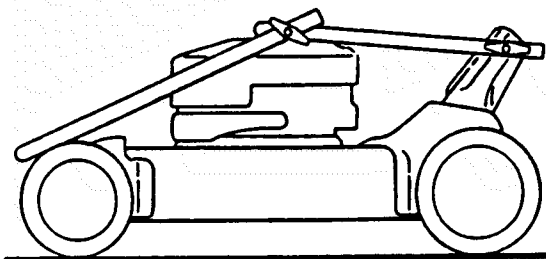

MOWER SHOWN AS REMOVED FROM SHIPPING CARTON WITH HANDLES FOLDED (PUSH MODEL SHOWN)

FIGURE 1

STEP 2: Remove and discard cardboard from between all handles. Raise upper handle until it is in line and seats into lower handle. Securely tighten upper handle T-Knobs on both sides. See Figure 2.

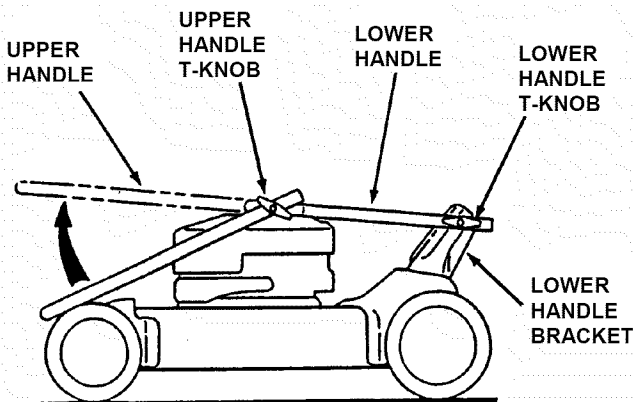

FIGURE 2

STEP 3: Raise upper and lower handle until it seats into position in the lower handle brackets. Securely tighten lower handle T-Knobs on both sides. See Figure 3.

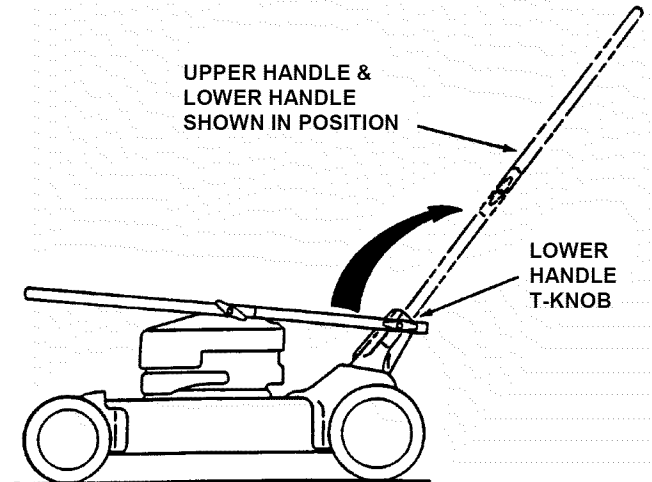

FIGURE 3

STEP 4: Tip mower back against the upper handle to gain access to cutting blade. Remove foam shipping block from cutting blade. This must be removed before starting the engine. **IMPORTANT: Wear heavy duty gloves when removing shipping block. Cutting blade is extremely sharp.**

IMPORTANT: DO NOT tip machine with carburetor or spark plug down. Oil from crankcase will saturate the air filter and cause the engine to be hard to start or not start at all. If contamination does occur, the air filter will have to be replaced.

STEP 5: Handle height is adjustable for different height of operators. Loosen the three nuts on the inside of each of the lower handles. See Figure 4.

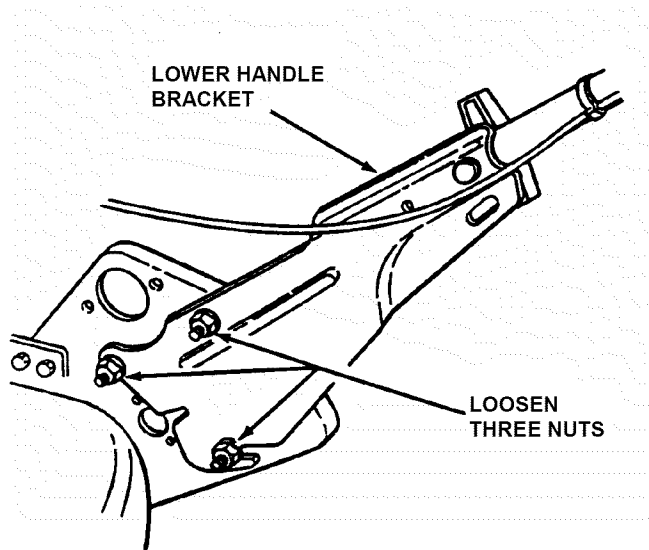

FIGURE 4

STEP 6: Move the handle up or down to the desired height. See Figure 5. Retighten all nuts loosened in step 5 securely after adjustment.

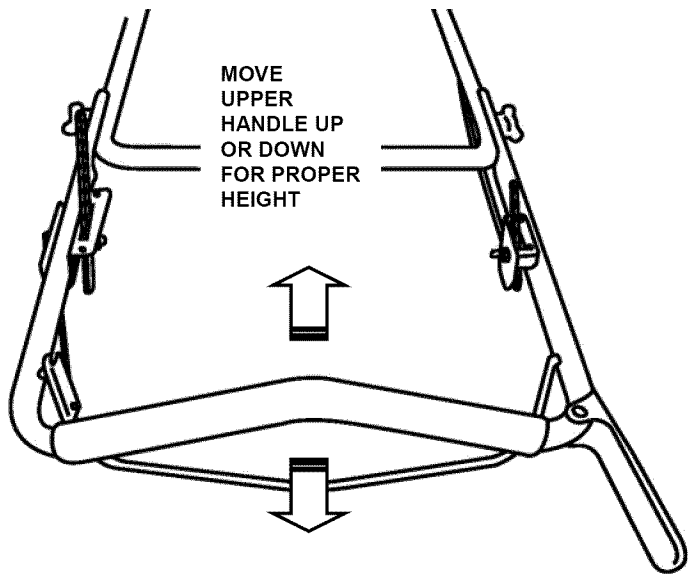

FIGURE 5

STEP 7: Squeezing brake control against upper handle, grasp engine recoil and pull firmly past recoil rope guide on right side of upper handle. Hook recoil rope into eye of rope guide. See Figure 6.

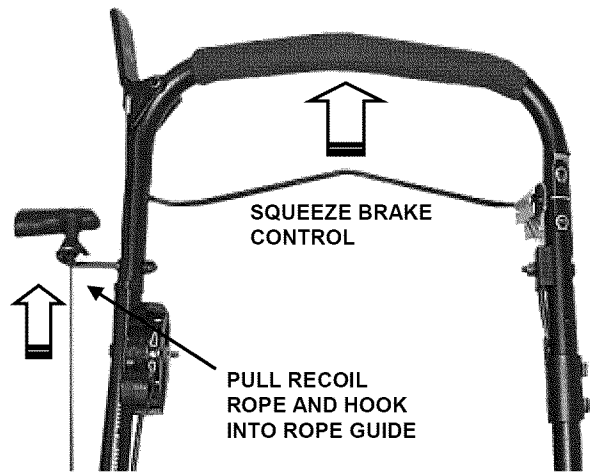

FIGURE 6

STEP 8:

1. Install Operator console onto upper handle section with four 1/4-20 x 1/2" torx screws. See Figure 7.
2. Firmly press Engine speed handle onto right lever as shown.
3. (Self-propelled models only) Slip ground speed handle onto left lever as shown, securing with one 8-32 x 1/2" round head machine screw and hex nut. (Be sure nut sets into hexagonal depression in side of handle.)

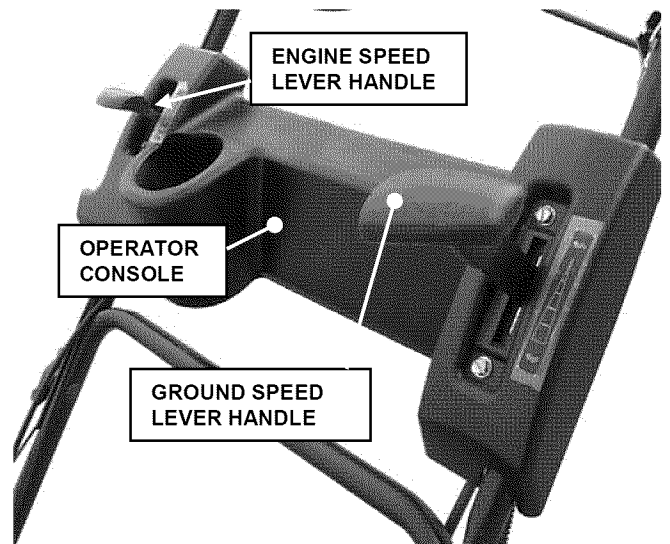

FIGURE 7

DRIVE ASSEMBLY (SELF-PROPELLED UNITS ONLY)

STEP 1:

1. Remove driven disc spring from driven disc assembly as shown. See Figure 8.

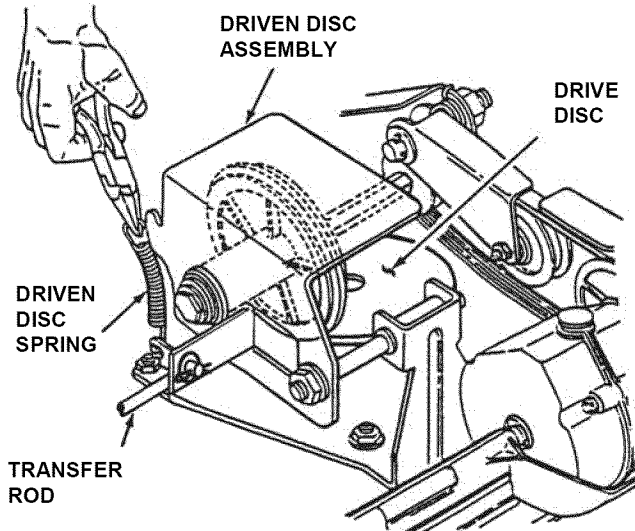

FIGURE 8

2. Manually adjust driven disc to position shown in Figure 9.

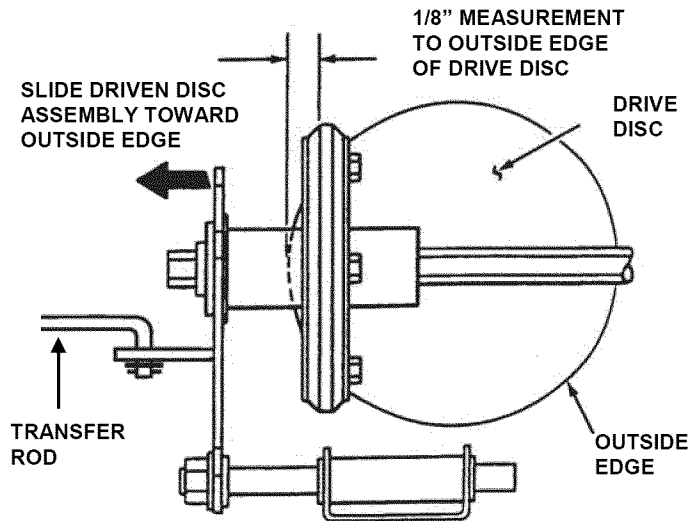

FIGURE 9

3. Slide Ground speed control lever fully forward. See Figure 10.
4. Install threaded end of Ground speed control rod, fitted with one 1/4-28 jam nut and one 1/4" internal tooth washer, into ball joint on end of speed control pivot arm. See Figure 11.
IMPORTANT: Do not move pivot arm.

5. Thread rod in until upper end of rod aligns with hole in bottom of ground speed control lever. See Figure 10. Insert upper end of rod into hole, and secure with 5/16" flat washer and hair pin.
6. Slide Ground speed lever back, then fully forward again. Check driven disc position. If needed, repeat #5 above until 1/8" in Figure 9 is maintained, then tighten jam nut securely against ball joint.
7. Replace driven disc spring to driven disc assembly. See Figure 8.

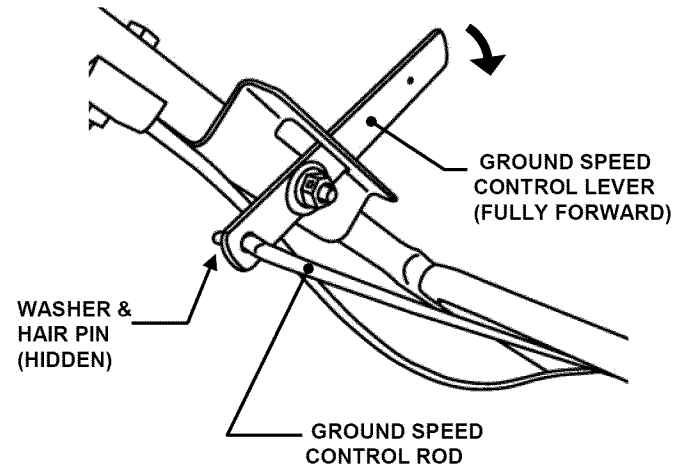

FIGURE 10
(Operator Console and Ground speed handle removed for clarity)

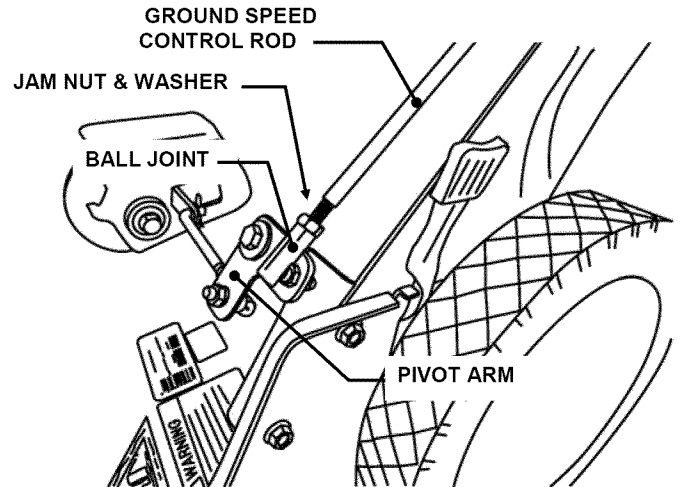

FIGURE 11

STEP 2:

IMPORTANT: Clutch cable adjustments are made to the machine at the factory. The following adjustments are provided for reference only. Complete all items on the Pre-Operation Checklist as instructed.

Check the clearance between the clutch cable and clutch spring. **NOTE:** Clearance between spring and cable is very important. Excessive clearance will cause drive system NOT to operate when wheel drive control handle is depressed. No clearance at all will cause mower to continue to propel itself when wheel drive control handle is released to stop mower movement. Slide vinyl spring cover (located at the end of clutch cable) up clutch cable to gain access to the end of spring and cable loop. With wheel drive control handle released, clearance between spring hook and cable loop should be 1/16" to 1/8". If clearance is more or less than specified, unhook spring from clutch cable eye, then adjust by turning inner spring in an opposite direction than the outer spring. Rehook spring to clutch cable eye. Slide vinyl cover over the spring when correct clearance is reached. See Figure 12.

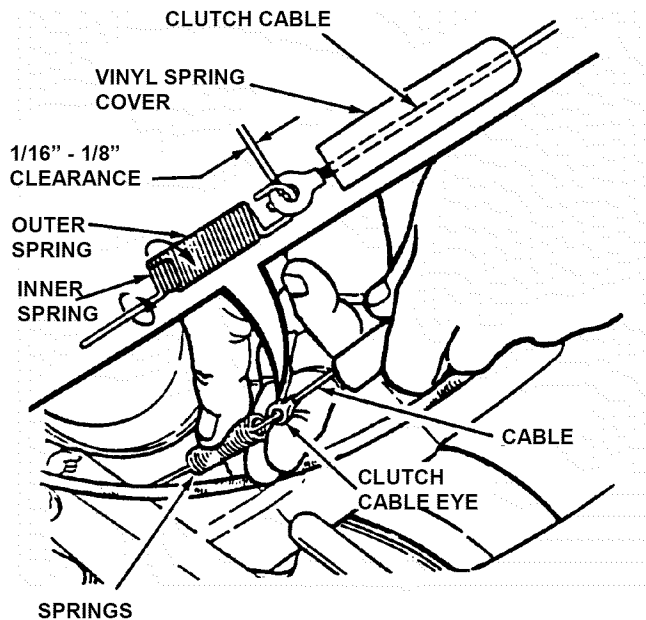

FIGURE 12

DISCHARGE ASSEMBLY

NOTE: Discharge assemblies vary by model. Some assembly steps shown may not apply to your model.

GRASS BAG

STEP 1: Install the grass bag adapter and secure to the side and top of the deck with the two nuts provided with the machine. Slot in front edge of adapter must be under nut located on top of deck. See Figure 13.

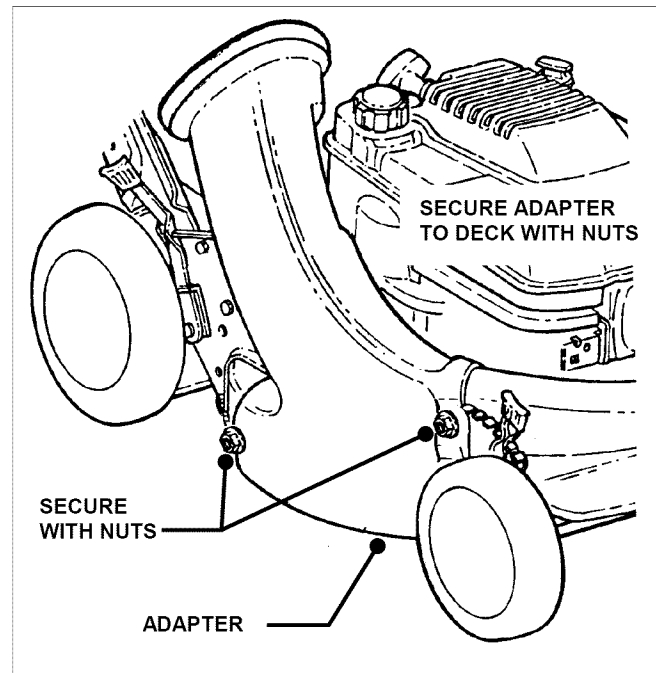

FIGURE 13

STEP 1a (Kawasaki only): Attach Bag Adapter Standoff between rope guide pulley assembly and engine recoil. See Figure 13a.

- Remove right rear bolt from engine recoil cover.
- Remove torx screw and nut securing rope guide pulley to bracket on bag adapter.
- Lay standoff between bolt holes in engine recoil cover and bag adapter pulley bracket. **NOTE:** position standoff so that bent end is toward engine recoil cover.
- Flip pulley over so that flange of steel bushing is under pulley. (The bushing will act as a washer between the pulley and standoff.)
- Reassemble pulley to bag adapter, and install supplied replacement bolt, fitted with thread sleeve, into recoil cover. Tighten all hardware securely.

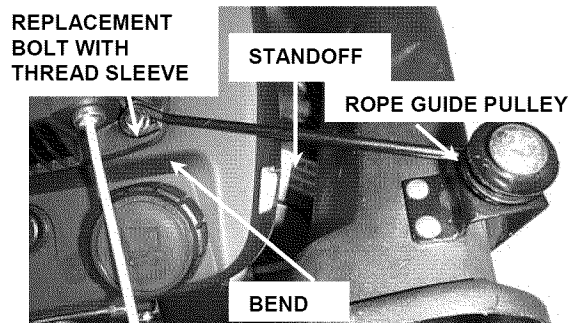

FIGURE 13a

STEP 2: Install grass bag by sliding connector over flange of adapter. See Figure 14. Attach grass bag hooks over middle handle cross bar. See Figure 15.

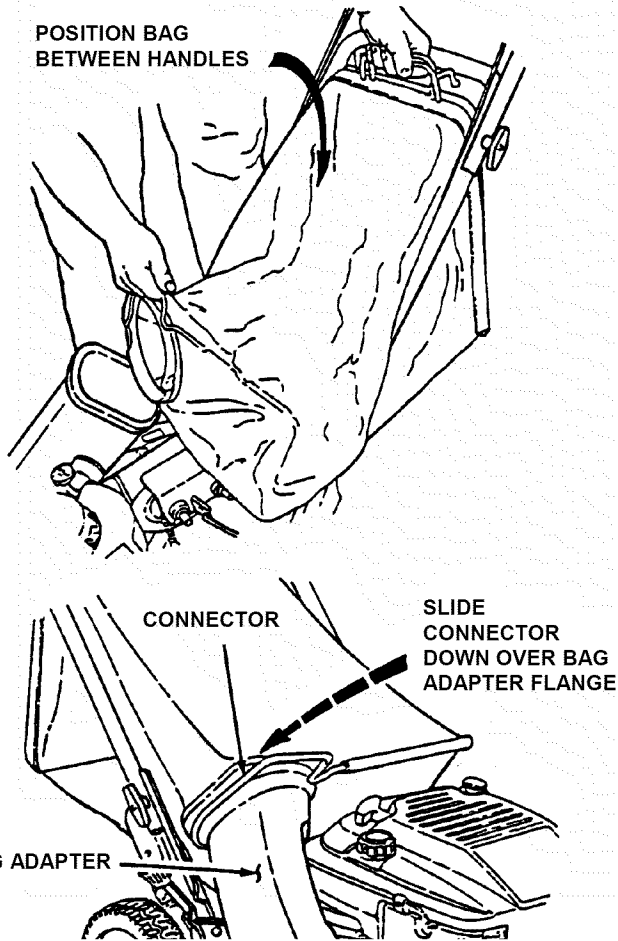

FIGURE 14

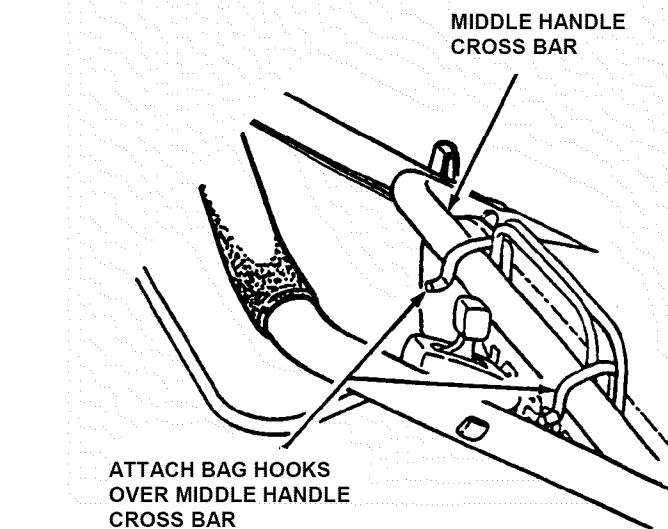

FIGURE 15

STEP 3: Route recoil rope around guide pulley on top of bag adapter. See Figure 16.

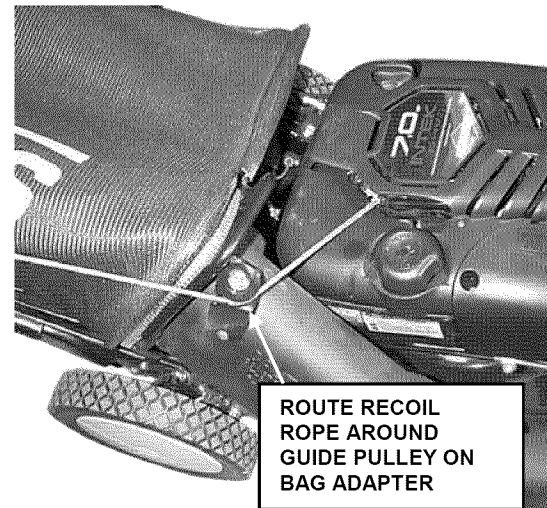

FIGURE 16

STEP 4:
RECYCLING PLUG
(Optional Accessory on Some Models)

Once grass bag assembly has been installed, recycling may be desired. Remove grass bag. Insert recycling plug completely and securely into adapter. See Figure 17. Reinstall grass bag as a safeguard.

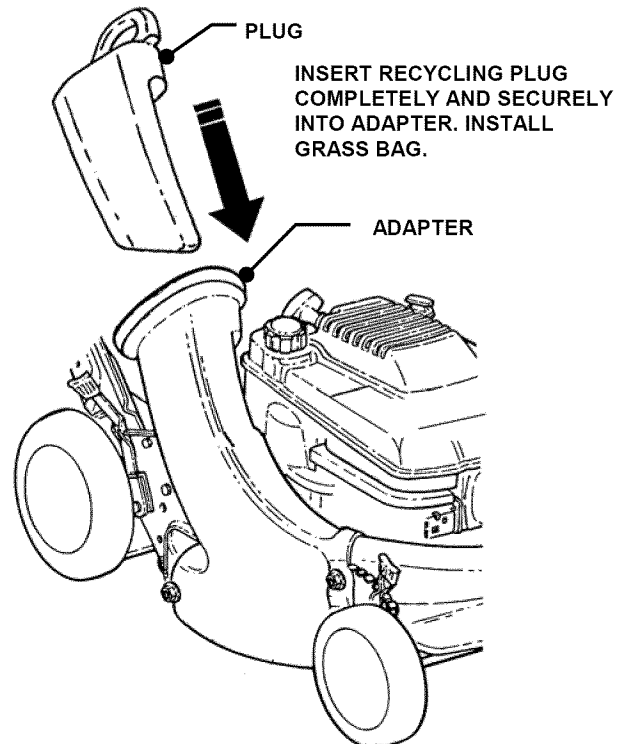

FIGURE 17

DISCHARGE DEFLECTOR

(Optional Accessory on Some Models)

Install discharge deflector if discharging is desired. Grass bag and bag adapter must be removed.

- A. Remove grass bag from handle and bag adapter. See Figure 18.
- B. Remove front and rear nuts attaching bag adapter to deck. See Figure 18.



FIGURE 18

- C. Install discharge deflector and secure to deck using hardware just removed in Step A. Slot in front edge of discharge deflector must be under nut as shown and both bolts protruding through holes in the side of the deflector. Secure nuts to the side of deflector. Tighten nuts securely. See Figure 19.

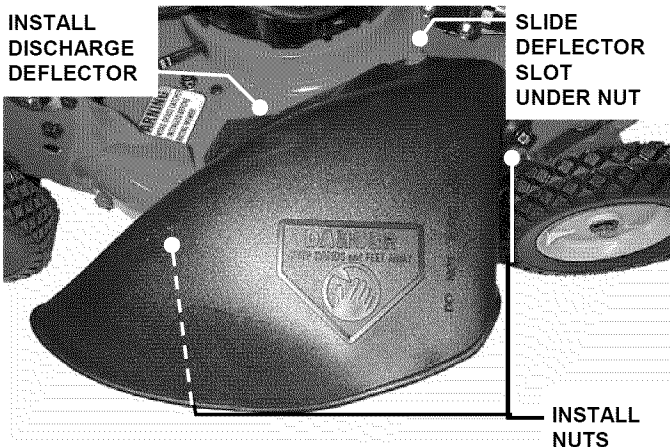

FIGURE 19

RECYCLING COVER

(Optional Accessory on Some Models)

Install the recycling cover and secure to the side and top of the deck with the two nuts provided on the machine. Slide top portion of cover under nut and make sure the slot is completely underneath the nut. See Figure 20.

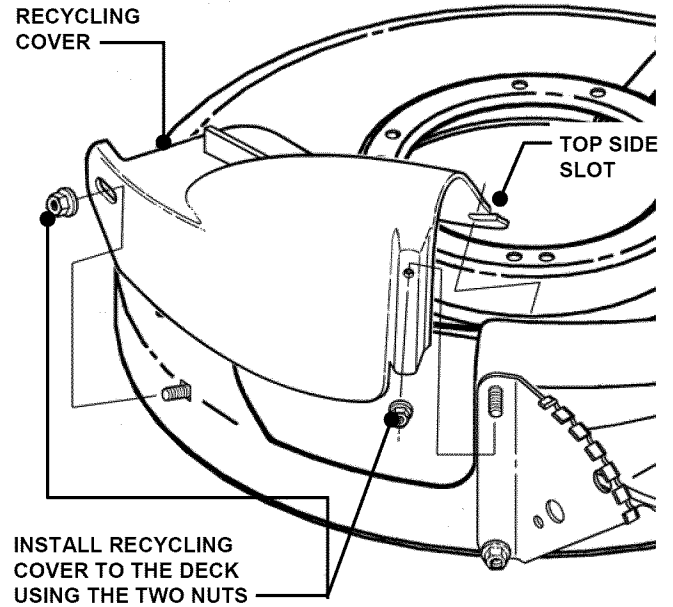

FIGURE 20

| | | |
|--|----------------|--|
| | WARNING | |
| <p>DO NOT operate without entire Grass Catcher or guard in place. Grass Catcher components are subject to deterioration during normal use. Inspect frequently and replace worn or damaged components immediately.</p> | | |

CHECKLIST: Complete all items on the Pre-Operation Checklist as instructed. For electric start models, continue to the "Electric Start Models" Section.

ELECTRIC START MODELS

WARNING

The electrolyte (acid) produces a highly explosive gas. Keep all sparks, flame and fire away from area when charging battery or when handling electrolyte or battery. Electrolyte (acid) is a highly corrosive liquid. Wear eye protection. Wash affected areas immediately after having eye or skin contact with electrolyte (acid). Battery acid is corrosive. Rinse empty acid containers with water and mutilate before discarding. If acid is spilled on battery, bench, or clothing, etc. Flush with clear water and neutralize with baking soda. Never attempt to charge battery while installed on the walk behind. Never use "BOOST" chargers on the battery.

IMPORTANT NOTE: Be sure all previous assembly steps pertaining to your mower have been completed before connecting battery.

STEP 1: Remove grass bag (if installed).

STEP 2: Activate and charge the battery as follows:

- A. Remove battery from carton.
 - B. Place battery in a well ventilated area on a level surface.
 - C. Remove battery cell caps. Fill cells as required with electrolyte to proper level. See Figure 21.
- NOTE: Electrolyte (Acid) is shipped with battery.

IMPORTANT: Never place anything in battery other than specified electrolyte.

WARNING
DO NOT OVERFILL!

- D. With cell caps removed, connect battery charger to battery terminals; RED to positive (+) and BLACK to negative (-) terminal.
- E. Slow charge battery at 1 amp for 2 hours to bring the battery to full charge.
- F. After charging, reinstall cell caps.

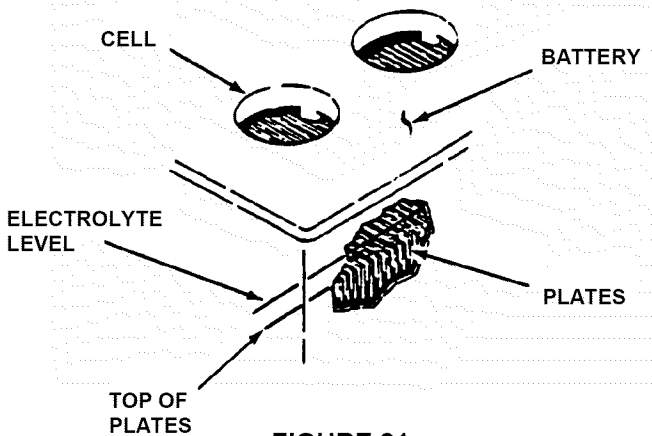

FIGURE 21

STEP 3: Route upper end of harness through hole in control console gusset, and plug harness connector up into ignition. (NOTE: Harness runs up along left side of handle assembly).

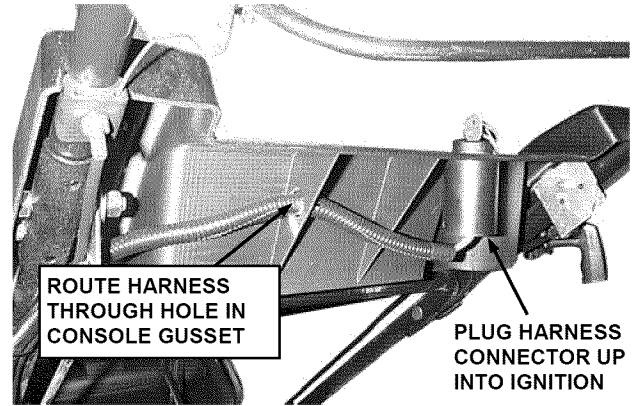

FIGURE 22

STEP 4: Loosen nut that secures top bracket to lower bracket, and remove top bracket. Install battery into lower bracket as shown in Figure 23. Reinstall top bracket and retighten nut securely.

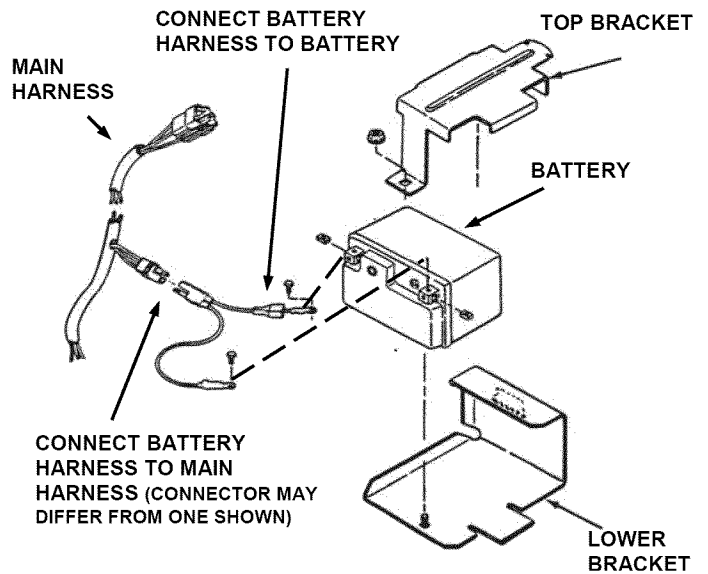

FIGURE 23

STEP 5: Connect red positive (+) cable and black negative (-) cable from battery harness to the positive terminal and negative terminal on battery using nuts and bolts.

WARNING

Shield the positive terminal with terminal cover located on battery harness. This prevents metal from touching the positive terminal, which could cause sparks.

Assembly is complete. Complete all items on the Pre-Operation Checklist as instructed.

PRE OPERATION CHECKLIST for SNAPPER 21" STEEL DECK WALK BEHIND MOWERS

Snapper has completed initial adjustments and performed operational tests prior to shipping the machine. Due to the possible effects of shipping, handling and storage, Snapper intends for all of the following items to be verified and necessary final adjustments made at time of setup. It remains good practice and is strongly recommended that all the items also be checked prior to placing the machine into service. It is very important that setup is verified and all operational tests completed and results are acceptable. After completing this form, sign and retain for future reference.

SET-UP (Details on Pages 1 through 5 of this Instruction)

- UPPER HANDLE & LOWER HANDLE secured in place and hardware tightened securely.
- FOAM SHIPPING BLOCK removed from cutting blade.
- RECOIL ROPE hooked into rope guide on handle.
- OPERATOR CONSOLE installed, engine speed and ground speed * handles installed. (*Self-Propelled units)
- DRIVE ASSEMBLY COMPONENTS installed and adjusted correctly. (Self-Propelled units)
- SIDE CHUTE, RECYCLING COVER or GRASS BAG installed correctly on mower.
- BLADE retaining bolt(s) checked and tighten securely.
- BATTERY, electrolyte added to proper level, charged and installed. All cables connected (Electric Start Models).

LUBRICATION

- ENGINE OIL added to bring level up to full mark on 4-cycle engines (Refer to Engine Manual).
- OIL mixed with FUEL in specified ratio (2 Cycle Engines Only).
- DIFFERENTIAL grease checked and added if needed.

OPERATIONAL TEST

- ENGINE started, engine control settings checked and adjusted as needed.
- WHEEL DRIVE checked for proper operation and adjusted as needed (Self-Propelled Models).
- DRIVE DISC adjustment checked and made (Self-Propelled Models).
- GROUND SPEED control checked (Self-Propelled Models).

CPSC (Consumer Product Safety Commission) COMPLIANCE TEST

- BLADE CONTROL stops engine when released.

CONSUMER/OPERATOR PRODUCT REGISTRATION CARD

Purchase Date _____ Model _____ Serial No. _____

Retailers Name _____ Signature _____

Address _____ City _____ State _____ Zip _____

MACHINE WILL BE USED COMMERCIALY? YES NO

Purchaser's Name _____ Signature _____

Address _____ City _____ State _____ Zip _____

IMPORTANT: This form is to be retained for future reference regarding Warranty, proof of purchase, traceability for product recall or service, etc. Complete the Product Registration Card and Mail to Customer Service Department at SNAPPER, P.O. BOX 1379, McDonough, Georgia, 30253.