

# Use and Care Guide



## Outdoor Table Top Grill

Kenmore Model No.: 122.16104800

Kmart Item No.: 640-845698-117

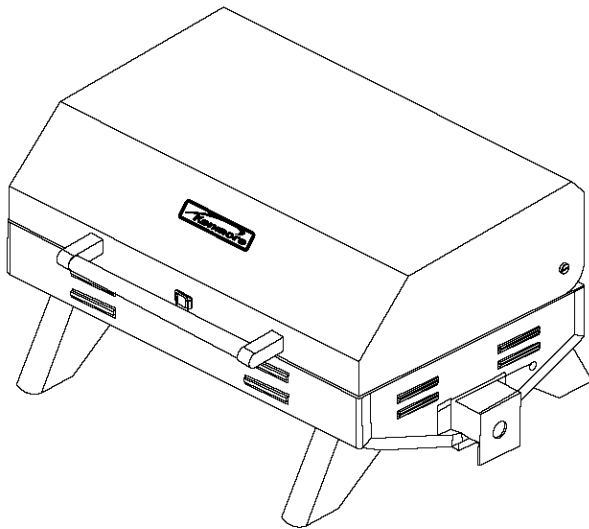

- Parts
- Assembly
- Safety Rules
- Use and Care
- Troubleshooting
- Español (Pg. 15)



### **WARNING:**

Read this Owner's manual carefully and be sure your gas grill is properly assembled, installed and maintained. Failure to follow these instructions could result in serious injury and/or property damage. This gas grill is intended for outdoor use only and is not intended to be installed in or on recreational vehicles or boats.

### **Note to Installer**

Leave this Owner's Manual with the customer after delivery and/or installation.

### **Note to Consumer**

Leave this Owner's Manual in a convenient place for future reference.

### **Customer Service Helpline:**

For parts ordering, call:  
1-800-4-MY-HOME

For assembly questions, call:  
1-800-913-8999

Date: 2007/06/06

## Table of Contents

Warranty-----	2
Safety Precautions-----	2~5
Package Contents List-----	5
Parts Diagram -----	6
Parts List-----	6
Assembly Instructions-----	7
Operation Instructions-----	8~9
Care and Maintenance-----	10~11
Troubleshooting-----	11
Cooking Instruction-----	12
Cooking Chart-----	13

## Kenmore Grill Warranty

### One-Year Full Warranty on Kenmore Grill

If this grill fails due to a defecting material or workmanship within one year from the date of purchase, call 1-800-4-MY-HOME plus a registered trademark to arrange for free repair (or replacement if repair proves impossible).

### Five-Year Limited Warranty on Stainless Steel Burners

For five years from the date of purchase, any stainless steel burner that rusts through will be replaced free of charge. After the first year from the date of purchase, you pay for labor if you wish to have it installed.

All warranty coverage excludes ignitor batteries and grill part paint loss, discoloration or rusting, which are either expendable parts that can wear out from normal use within the warranty period, or are conditions that can be the result of normal use, accident or improper maintenance,

All warranty coverage is void if this grill is ever used for commercial or rental purposes.

All warranty coverage applies only if this grill is used in the United States.

This warranty gives you specific legal rights, and you may have other right which vary from state to state.

**Sears, Roebuck and Co.,  
Hoffman Estates, IL 60179  
U.S.A.**

## PRECAUTIONS

### **WARNING**

Combustion by products produced when using this product contain chemicals known to the State of California to cause cancer, birth defects, or other reproductive harm.

### **WARNING**

Failure to comply with these instructions could result in a fire or explosion that could cause serious bodily injury, death, or property damage.

### **WARNING**

**Your grill will get very hot.** Never lean over the cooking area while using your grill. Do not touch cooking surfaces, grill housing, lid or any other grill parts while the grill is in operation, or until the gas grill has cooled down after use.

**Failure to comply with these instructions may result in serious bodily injury.**

### **WARNING**

1. Do not store or use gasoline or other flammable material and liquids in the vicinity of this or any other appliance.
2. A LP cylinder not connected for use must not be stored in the vicinity of this or any other appliance.

### **DANGER**

If you smell gas:

1. Shut off gas to the appliance.
2. Extinguish any open flame.
3. Open Lid.
4. If odor continues, keep away from the appliance and immediately call your gas supplier or your fire department.

### Grill Installation Codes

The installation must conform with local codes or, in the absence of local codes, with either the national fuel gas code, ANSIZ 223.1/NFPA S4, Natural gas and propane installation code, CSA B149.1, or propane storage and handling code, B149.2, or the standard for Recreational vehicles, ANSI A 119.2, and CSA Z240 RV series recreational vehicle code, as applicable.

LP gas grill models are designed for use with a standard 20 lb. Liquid Propane Gas tank, not included with grill. Never connect your gas grill to an LP gas tank that exceeds this capacity.



## SAFETY INFORMATION

Please read the following instructions carefully before attempting to assemble, operate or install the product. Failure to follow these instructions may result in serious bodily injury and/or property damage. If you have questions regarding the product please call customer service at 1-800-913-8999.

LP- gas supply cylinder to be used must be constructed and marked in accordance with the specifications for LP-gas cylinders of the U.S Department of Transportation (DOT) or the National Standard of Canada, CAN-B339, Cylinders, Spheres and Tubes for the Transportation of Dangerous Goods.

1. The installation must conform with local codes or, in the absence of local codes, with the National Fuel Gas Codes, with the National Fuel Gas Code, ANSI Z223.1/NFPA 54, Storage and Handling of Liquefied Petroleum Gases, ANSI/NFPA 58, or the Standard for Recreational Vehicles, ANSI A119.2/NFPA 1192, and the Recreational Vehicle Code, CSA Z240 RV, as applicable.
2. Table top grill is for outdoor use only. Grill should be operated in a well-ventilated space. Never operate in an enclosed space, garage or building. Your grill is not intended to be installed in or on recreational vehicles and / or boats .
3. Heated liquids remain at scalding temperatures long after the cooking process. Do not touch the cooking appliance until liquids have cooled to 115°F (45°C) or less.
4. Do not install or use grill within 24" (10ft recommended) of combustible materials from back and sides of grill. Grill shall not be located under overhead surfaces (closed carport, garage, porch, patio) that can catch fire.
5. Never attempt to attach this grill to the self-contained LP gas system of a camper trailer or motor home.
6. It is the responsibility of the assembler/owner to assemble, install and maintain gas grill. Do not let children and pets operate or play near your table top grill. Failure to follow these instructions could result in serious personal injury and/ or property damage.
7. Remove lid before lighting grill. When grill is not in use, turn off control knob on regulator.
8. Carefully follow instructions in this manual for proper assembly and leak testing of your grill. Do not use grill until leak checked. If leak is detected at any time, it must be stopped and corrected before using grill further.
9. Appliance area should be kept clear and free from combustible materials, gasoline, bottled gas in any form and other flammable vapors and liquids. Do not obstruct flow of combustion and ventilation air.
10. Ensure proper bottle position prior to lighting your grill. Bottle should be vertical.
11. Never try to light grill with lid closed! Buildup of gases is very dangerous and could cause an explosion.
12. Keep any electrical cord or fuel supply hose away from any heated surfaces.
13. Propane is a flammable gas and improper handling may result in explosion and/or fire and serious accident or injury.
14. Do not allow oil or grease to get hotter than 400°F (200°C) or if oil begins to smoke, immediately turn the burner or gas supply "OFF" and wait for the temperature to decrease to less than 350°F (175°C).
15. This appliance will be during and after use. Use insulated oven mitts or gloves for protection from hot surfaces or splatter from cooking liquids.
16. Do not leave your grill unattended while in operation.
17. Do not use while under the influence of drugs or alcohol.
18. Do not store any spare LP (propane) cylinder, full or empty, under or near your grill.
19. Appliance is not intended for commercial use or rental.
20. The cylinder must be disconnected when the appliance is not in use.
21. This instructions manual contains important information necessary for the proper assembly and safe use of the appliance.
22. Read and follow all warnings and instructions before assembling and using the appliance.
23. Follow all warnings and instructions when using the appliance.
24. Keep this manual for future reference.

### CAUTION: Beware of Flash-back

CAUTION: Spiders and small insects occasionally spin webs or make nests in the grill burner tubes during transit and warehousing. These webs can lead to gas flow obstruction which could result in a fire in and around burner tubes. This type of fire is known as "FLASH-BACK" and can cause serious damage to your grill and create an unsafe operating condition for the user.

Although an obstructed burner tube is not the only cause of "FLASH-BACK", it is the most common cause.

To reduce the chance of "FLASH-BACK", you must clean the burner tubes before assembling your grill, and at least once a month in late summer or early fall when spiders are most active. Also perform this burner tube cleaning procedure if your grill has not been used for an extended period of time.

See instructions on cleaning burner tube on page 10.

## SAFETY INFORMATION

### The Fuel System

Gas grills are used safely by millions of people when following simple safety precautions.

The items in the fuel system are designed for operation with this Kenmore grill. They must not be replaced with any other brand. (See parts list for replacement items.)

**GAS BURNER:** The gas burner is constructed of tubular stainless steel and should not require maintenance other than inspection for insects/nests inside the air intake slots.

**BURNER VALVE/REGULATOR:** The burner control is actually a regulator/valve assembly. The regulator attaches directly to the end of the burner, which extends out of the right end of the grill by a 1-pound propane cylinder threads into the regulator. **Only a factory supplied gas valve/regulator must be used.** (See parts list for replacement items.)

### LP GAS REGULATOR CAUTION

The gas pressure regulator provided with this appliance must be used. This regulator is equipped with the required orifice and is set for the required outlet pressure for this appliance. This combination of orifice size and pressure regulation specifications provides the cooking performance intended by Kenmore Table Top Grill. Substitution of regulator by any other device or any other manufacturer is dangerous and could result in serious injury.

### LP GAS REGULATOR

The gas pressure regulator is shipped loose and must be installed prior to operating your grill. This is a "slip-fit"~ requiring no tools. See assembly instructions on page 7 for proper installation. The regulator may be removed from the grill after use. Turn the regulator control knob to the "OFF" position; disconnect the LP cylinder and allow the grill to cool for at least 30 minutes prior to removing regulator.

Care should be taken to store the regulator in a clean, secure location when the grill is not in use. The threaded cylinder connection area should be kept clean and free of dust, dirt, sand or any foreign materials. Clean both the regulator and LP cylinder threaded areas prior to connecting cylinder to regulator.

**PROPANE FUEL: WARNING** - propane is a flammable gas. Improper handling may result in an explosion and/or fire and serious accident or injury. Your grill is designed to operate with propane (LP) gas only and is equipped with the proper orifice for propane gas.

**WARNING:** Do not connect this grill with any gas supply other than propane. Propane gas is heavier than air and settles in lower areas. Make certain adequate ventilation is available when using your grill. The gas cylinder may be stored outside in a well-ventilated area out of the reach of children when the grill is not in use.

**LP GAS CYLINDER:** This grill is designed and intended to be used with a disposable propane cylinder with a nominal fuel weight of 1 lb. Such a cylinder is approximately 4" in diameter and 7" long. The Kenmore Table Top Grill does not include an LP gas cylinder. This must be purchased separately and be found at most hardware stores. The cylinder used must be constructed in accordance with the specifications for LP cylinders of the U.S. Department of Transportation (DOT) DOT-39 NRC232/290 MIIIO.

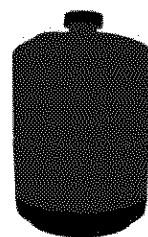

## **SAFETY INFORMATION**

The LP gas cylinder shall be used only outdoors in a well-ventilated space and not in a building, garage, or any other enclosed area. The Kenmore Table Top Grill may be stored indoors if the LP gas cylinder is removed and stored outdoors. The LP gas cylinder (not included) is threaded for connection directly to the gas regulator supplied with this appliance. Care should be taken when threading the cylinder to the regulator to engage threads correctly to achieve the proper and intended connection. When disconnecting or connecting the gas cylinder, be careful that the regulator does not strike the grill, the ground, or any other surfaces. Replace the protective cap over the threaded cylinder connection when removed from grill. If any difficulty occurs when connecting or disconnecting the cylinder to the regulator assembly, contact your local gas supplier for assistance.

When re-connecting the LP gas cylinder to the regulator, be sure to hand-tighten until snug. This connection should be inspected for damage and leak tested after each re-connection.

To leak test, make a soap solution of one part liquid detergent and one part water. You will need a spray bottle, brush, or rag to apply the solution to the cylinder-regulator connection. Bubbles indicate leaks.

## **PACKAGE CONTENTS LIST**

Part	Description	Quantity
1	Grill	1 set
2	Regulator	1 set

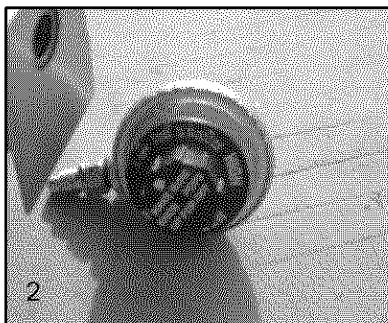
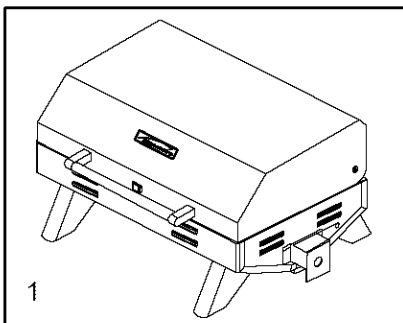

## **PREPARATION**

Before beginning assembly, installation or operation of product, make sure all parts are present. Compare parts with package contents list and diagram above. If any part is missing or damaged, do not attempt to assemble, install or operate the product. Contact customer service for replacement parts at 1-800-4-MY-HOME.

- Your Kenmore Table Top Grill is pre-assembled. The only assembly required is to connect the gas regulator into the grill.
- Estimated Assembly Time: 5-8 minutes.
- Tools Required for Assembly: Wrench.

## PARTS DIAGRAM & LIST

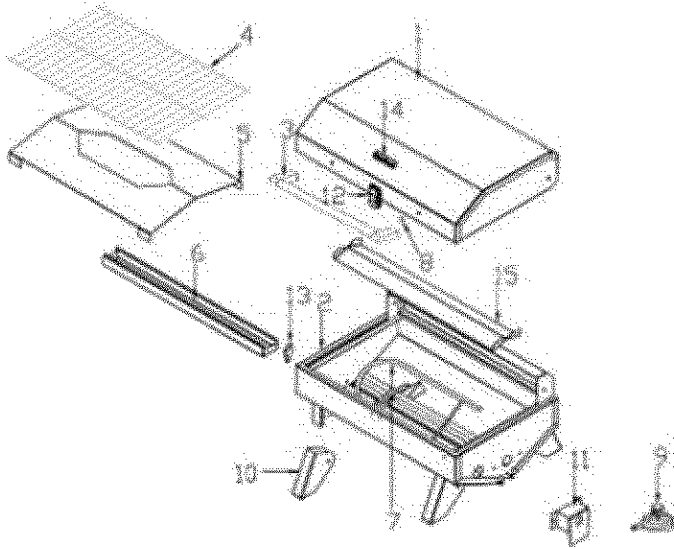

Part	Description	Part #
1	Main Lid	1 set
2	Main Burner Bowl Assembly	1 set
3	Main Lid Handle	1 set
4	Cooking Grid	1 pc
5	Flame Tamer	1 pc
6	Grease Tray	1 pc
7	Main Burner	1 pc
8	Main Lid Handle Seat	2 pc
9	Regulator, LP	1 set
10	Foldable Leg	4 set
11	Gas Collector Box	1 pc
12	Latch	1 set
13	Grease Tray Latch	1 pc
14	Logo	1 pc
15	Firebox Heat Shield	1pc
16	Manual	1 pc
17	Hardware	1pc

For assembly questions, call:  
1-800-913-8999

For parts ordering, please call:  
1-800-4-MY-HOME

To make sure you obtain the correct replacement parts for your Kenmore gas grill, please refer to the part numbers on this page.

Important: Use only parts listed above. When ordering parts, providing the following information:

1. Model #
2. Part Number (see PART# in chart)
3. Part Description
4. Quantity of parts needed

**Important:** Keep this Owner's Manual for convenient reference and for part replacement.

## ASSEMBLY INSTRUCTIONS

1. Locate the gas regulator (1-1). Grasp the regulator (1-1) with the knob (1-2) facing directly up. Line up the collar on the regulator (1-1) with the open end of the burner tube (1-3) as shown in fig. 1.

**Fig. 1**

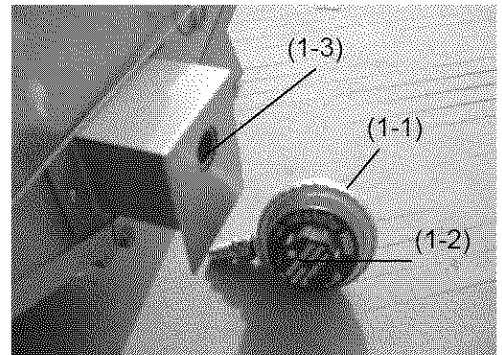

2. Screw the regulator (2-1) into the open end of burner (2-2) as shown in fig. 2.

**Fig. 2**

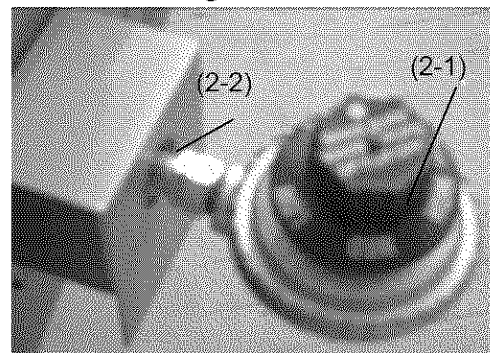

3. Once the regulator is in as far as it will go, tighten with a wrench. Turn the regulator so that the knob is facing forward. Note: Always make sure the regulator is secured facing forward in the fully lock-in position before attaching propane cylinder.

4. (3-2) Be sure the gas control knob (3-1) is in the "OFF" position. Check to make sure threaded areas on cylinder and regulator are clean. Screw the propane cylinder (3-2) onto the regulator (3-3) making sure to engage threads correctly to achieve proper connection. To remove the propane cylinder (3-2) unthread the cylinder from the regulator (3-3) as shown in fig.3.

**Fig. 3**

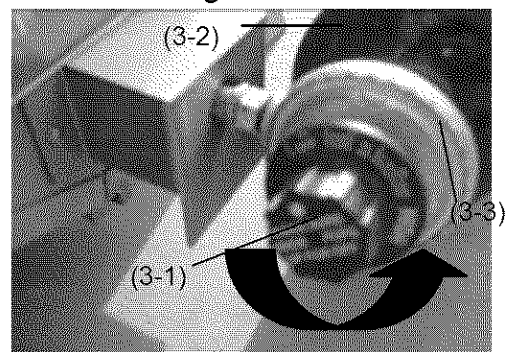

## OPERATION INSTRUCTIONS

### BURNER VALVE / REGULATOR

The burner control operates in the following positions indicated by the pointer at the top of the regulator as installed on the grill:

- OFF – This stops the flow of gas to the burner.
- PUSH TO TURN ON – Push “IN” on the knob to release the knob from the locked “OFF” position.
- HIGH – This position provides the highest gas flow and the hottest cooking temperatures.
- MED – This position provides cooking temperatures between HIGH and LOW.
- LOW – This position provides the lowest cooking temperatures.

### COOKING TEMPERATURE SETTINGS

- HIGH – Approximately 450°F
- MED – Approximately 400°F
- LOW – Approximately 350°F

Note: A disposable 1 lb. propane cylinder “NEAR EMPTY” can significantly reduce internal pressure and may affect the regulator’s capability to accurately control gas flow. As the propane cylinder reaches empty, this may cause “hotter-than-normal” cooking temperatures during the final minutes of use.

Note: A disposable 1 lb. propane cylinder will provide approximately 4-6 hours of cooking time with the Perfect Flame Table Top Grill.

### LIGHTING THE GRILL

1. Make sure the regulator is properly secured into the burner end.
2. Make sure the propane cylinder is tightly treaded into the regulator (hand tighten only).
3. Place the legs in the extended position as shown in Fig. 4.
4. Open lid. Always open lid when lighting.
5. Locate the lighting rod (4-1) on the right side of the grill as shown in fig. 4. Insert a match through the access hole (4-2) next to the burner tube. Keep flame next to the burner while actuating the gas control knob on the regulator.
6. Push the gas burner control knob “IN” and turn the control knob counterclockwise to the “lighting Position” while watching burner flame
7. If ignition does not occur in 3-5 seconds, turn the control knob “OFF”. Wait 5 minutes before attempting to re-light the grill. If the grill fails to ignite after the second attempt, call customer service at 1-800-913-8999 for assistance
8. With burner lit, gently close the lid and allow the grill to warm up for 20-30 minutes prior to use. **Note: If the burner should go out for any reason, turn the control knob to the “OFF” position. Wait 5 minutes before attempting to re-light.**

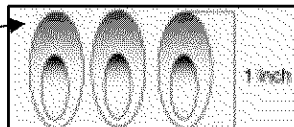
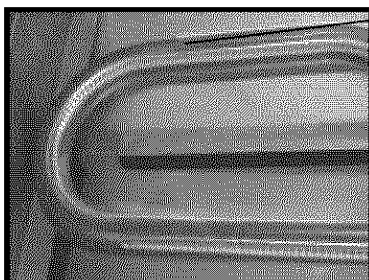
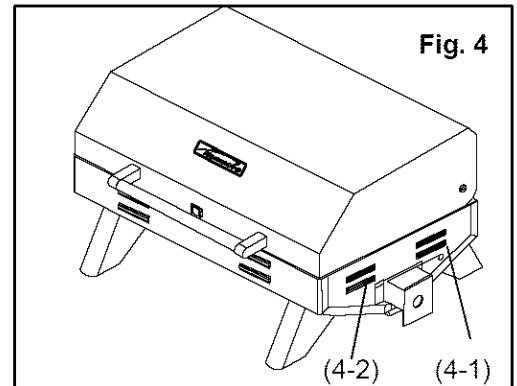

Visually check the burner flames prior to each use. The flames should look like this picture; if they do not, refer to the burner maintenance part of this manual.



## OPERATION INSTRUCTIONS

### TURNING THE GRILL OFF

1. Open the lid.
2. Turn the regulator control knob to the "OFF" position. **CAUTION:** Do not attempt to re-light the grill without following all the lighting instructions.
3. Allow the grill body to cool at least 30 minutes before attempting to move or transport.

### FLAME CHARACTERISTICS

Flames should be blue and stable with no yellow tips, excessive noise or lifting. Yellow flames indicate insufficient air. Noisy flames or flames that lift away from the burner indicate too much air. Also, check to see if the air shutter or burner ports are blocked by dirt, debris, spider webs, etc.

Typical flame pattern and proper flame height is shown in fig. 5

Fig. 5

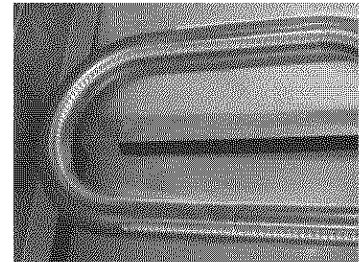

To adjust for proper flame, open burner cover & use a Philips screwdriver to loosen the screw (6-1) located in the main igniter gas collector. Turn the vent(6-2) clockwise to close the air shutter, and counterclockwise to open the air shutter as shown in fig. 6. After adjusting, tighten the screw to affix the air shutter.

Fig. 6

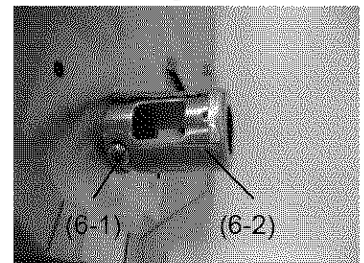

### USING THE GRILL

1. Find a level surface to grill on.
2. Allow the grill to warm up with the lid closed for 20-30 minutes prior to cooking.
3. The Perfect Flame Table Top Grill is equipped with an adjustable HIGH/MED/LOW control knob, which allows for complete flexibility in cooking temperatures.  
HIGH – Approximately 450°F  
MED – Approximately 400°F  
LOW – Approximately 350°F
4. You may cook on the grill in any weather. If the temperature is extremely cold or hot, the cooking times will be slightly increased or decreased. Keep the grill out of excessive winds when operating.
5. The cooking times listed below are only suggestions. Cooking times vary depending on thickness of meats and the desired degree of preparation.

### GRILLING

- Steak – (T-Bone), thick cut, medium doneness: grill 10 minutes on each side on MED setting.
- Chicken – (Quarters), average size fryer: grill 30 minutes per side on MED setting. Check for doneness.
- Pork – (Ribs/chops): grill 10-20 minutes per side on MED setting. Check for doneness.
- Fish – grill 20-30 minutes on LOW setting.
- Turkey - (Breast): grill 10 minutes per pound or until internal temperature reaches 170°F on MED setting.

## CARE AND MAINTENANCE

There is very little care and maintenance needed. The Kenmore Table Top Grill is designed and made of materials that will last many years with normal use. Following these instructions will improve the longevity and quality of cooking. To ensure safe operation of your grill, the area of cooking should always be kept free of combustible materials of any type, such as gasoline or other flammable vapors or liquids.

- Outside Grill Parts - This is stainless steel. It can be cleaned easily with warm soapy water or any stainless steel cleaner.
- Cooking Grid and Grease Tray - The cooking grid is made of high quality stainless steel. The cooking grid should be brushed with a steel brush immediately after cooking, while the grill is still warm. The grease tray is also stainless steel and can be cleaned with a flat scraper such as a putty knife. **CAUTION:** The grease tray must be kept clean and free of heavy buildup for the grill to perform properly and to eliminate flare-ups.
- Firebox - Use warm soapy water to clean this area. Do not allow grease to build up.
- Drain Hole - The drain hole must be kept clear of grease and food particles to allow drippings to drain properly into the grease tray. This must be done to maintain proper operation of your grill.
- Burner - Check burner air inlet openings (behind the inlet guard on the right end of the grill body) for insect nests or blockages. Make sure the slots in the burner tube are clear.
- Burner Tube - Using a bent stiff wire in the shape of a hook, air hose or a bottle brush, run it through the burner tube and inside several times to remove any debris.
- General - This grill, like all equipment, will look better and last longer if kept out of the weather when not in use. **CAUTION:** Do not store propane cylinders in enclosed areas. When using a cover or moving the grill, always wait until the grill has cooled for at least 30 minutes.
- Do not obstructing the flow of combustion and ventilation air.
- A clogged tube can lead to a fire beneath the appliance.

This unit **must** be kept in an area free from combustible materials, gasoline and other flammable vapors and liquids.

Make sure all openings into the grill body are free of blockages or debris and there are no objects or materials blocking the flow of combustion or ventilation. Make sure the legs are in the extended position when using the grill.

When the grill is not in use, turn the control knob to the "OFF" position and remove the propane cylinder from the regulator. Remove the regulator from the burner.

For outdoor use only, if stored indoors, detach propane cylinder and store outdoors. Propane cylinders must be stored out of reach of children.

### **IMPORTANT**

**First-time use:** It is important that the grill be lit and allowed to heat up at least 30 minutes before any food is placed on the cooking grid. It is normal for some smoke to appear during the initial operation of the grill. After initial heating, the grill is ready for use. A cooking spray can be used on the cooking grids to allow easier clean up.

**THIS COOKING APPLIANCE IS FOR OUTDOOR USE ONLY AND SHALL NOT BE USED IN A BUILDING, GARAGE OR ANY OTHER ENCLOSED AREA.**

### **MOVING INSTRUCTIONS**

**CAUTION:** Never move the grill with burner lit. Make sure control knob is in the "OFF" position. Disconnect the propane cylinder from the regulator. Remove the regulator from the grill. Be sure the grill has completely cooled for at least 30 minutes. Close the lid and secure the latch. Place the legs in the down position. Use the handle to carry the grill. Note: It is best to leave the grease tray in place attached to the bottom of the grill. Some grease may continue to drip from drain hole during transport.

**⚠ WARNING**

Spiders and insects can nest inside the burners of the grill and disrupt gas flow. This very dangerous condition could cause a fire behind the valve panel, thereby damaging the grill and making it unsafe for operation. Inspect the grill at least twice a year.

**When to Look for Spiders**

You should inspect the burners at least twice a year or immediately after any of the following conditions occur:

1. The smell of gas in conjunction with burner flames appearing yellow.
2. The grill does not reach temperature.
3. The grill heats unevenly.
4. The burners make popping noises.
5. See instructions on cleaning burner tube on page 10.

**TROUBLE SHOOTING**

**BEFORE CALLING FOR SERVICE**

<b>Problems</b>	<b>What To Do</b>
Grill will not light.	<ul style="list-style-type: none"><li>•Check to see if the liquid propane cylinder is empty.</li><li>•Check burner ports for any blockage. Use a soft wire brush to clear plugged ports.</li><li>•Check the gas orifice on the burner for an obstruction. If orifice is blocked, clean with a needle or thin wire. NEVER USE A WOODEN TOOTHPICK.</li></ul>
Burner flame is yellow or orange in conjunction with gas odor.	<ul style="list-style-type: none"><li>•Check for spiders and insects</li><li>•Call customer service at 1-800-913-8999</li></ul>
Low heat with the control knob on the “Hi” setting.	<ul style="list-style-type: none"><li>•Make sure the grill area is clear of dust.</li><li>•Make sure the burner and orifice are clean.</li><li>•Check for spiders and insects.</li><li>•Is there adequate gas supply available?</li><li>•Is the grill being preheated for 15 minutes?</li></ul>

## Cooking Instructions



### WARNING

**Do not leave the grill unattended. Your grill will get very hot.** Never lean over the cooking area while using your grill. Do not touch cooking surfaces, grill housing, Grill Lid or any other grill parts while the grill is in operation, or until the grill has cooled down after use. Failure to comply with these instructions may result in serious bodily injury.

### Burn-off

Before cooking on your gas grill for the first time, you will want to "burn off" the grill to eliminate any odor or foreign matter. Just ignite the burners, lower the Lid, and operate grill on the HIGH setting for 3 to 5 minutes.

### Cooking Temperatures

**High setting:** Only use this setting for fast warm-up, searing steaks or chops and for burning food residue off the grill after cooking is complete. **Never** use the HIGH setting for extended cooking.

**Medium to Low Settings:** Most recipes specify medium to low settings, including all smoking, rotisserie cooking and for cooking lean cuts such as fish.

**NOTE:** Temperature settings will vary with the temperature and the amount of wind outside your home.

### Direct Cooking

The direct cooking method can be used with the supplied cooking grids and food placed directly over the lit grill Burners. **Direct cooking requires the grill lid to be up.** This method is ideal for searing and whenever you want meat, poultry or fish to have an open-flame barbecued taste. Deep frying and smoking are also best cooked in this manner because they require direct heat.

### Indirect Cooking

To cook **indirectly**, the food should be placed on the left or right side of your grill with the burner lit on the opposite side. **Indirect cooking must be done with the Lid down.**

### Flare-ups

The fats and juices dripping from grilled food can cause flare-ups. Since flare-ups impart a favorably distinctive taste and color to food cooked over an open flame, they should be accepted up to a point. Nevertheless, uncontrolled flaring can result in a ruined meal.



### WARNING

Do not line the bottom of the grill housing with aluminum foil, sand or any substance that will restrict the flow of grease into the grease tray. Failure to comply with these instructions could result in a fire or explosion which could cause serious bodily injury, death, or property damage.

# GRILL COOKING CHART

FOOD	Weight or thickness	Temperature	Time	Special instructions and tips
Vegetables	NA	Medium	8 to 20 minutes	Slice or chop vegetables and dot with butter or margarine. Wrap tightly in heavy duty foil. Grill turning occasionally.
Potatoes	Whole	Medium	40 to 60 minutes	Wrap individually in heavy duty foil. Cook rotating occasionally.
Meat/Steaks	1/2 to 3/4 inches	High-Medium	4 to 15 minutes	Pre heat grill for 15-20 minutes then sear steaks on each side for two minutes. Next grill 3 to 5 minutes on each side or until desired doneness.
Ground Meats	1/2 to 3/4 inches	Medium	8 to 15 minutes	Grill turning once when juices rise to the surface or until desired amount of doneness. Do not leave hamburgers unattended since a flare-up could occur quickly.
Ribs	1/2 or full rack	Medium	20 to 40 minutes	Grill turning occasionally. During last few minutes brush with barbecue sauce, turn several times.
Hot dogs	NA	Medium	5 to 10 minutes	Grill turning four times. 2-4 minutes on each of four sides.
Poultry-Cut	1/4 to 1/2 pounds	Low or Medium	20 to 40 minutes	Grill turning occasionally. During last few minutes brush with barbecue sauce if desired, turn several times.
Poultry Whole	2 to 3 pounds	Low or	1 to 1-1/2 hours	Use poultry stand and brush frequently as desired
		Medium	40 to 60 minutes	Use poultry stand and brush frequently as desired
Fish	3/4 to 1 inch	Medium	8 to 15 minutes	Grill turning once to desired doneness. Brush with melted butter, margarine or oil.

# Get it fixed, at your home or ours!

## Your Home

For repair – in your home – of all major brand appliances, lawn and garden equipment, or heating and cooling systems, no matter who made it, no matter who sold it!

For the replacement parts, accessories and owner's manuals that you need to do-it-yourself.

For Sears professional installation of home appliances and items like garage door openers and water heaters.

**1-800-4-MY-HOME<sup>®</sup>** (1-800-469-4663)

Call anytime, day or night (U.S.A. and Canada)

[www.sears.com](http://www.sears.com)    [www.sears.ca](http://www.sears.ca)

For expert home solutions advice: [www.managemyhome.com](http://www.managemyhome.com)

---

## Our Home

For repair of carry-in items like vacuums, lawn equipment, and electronics, call or go on-line for the location of your nearest

**Sears Parts & Repair Service Center**

**1-800-488-1222** (U.S.A.)    **1-800-469-4663** (Canada)

Call anytime, day or night

[www.sears.com](http://www.sears.com)    [www.sears.ca](http://www.sears.ca)

---

To purchase a protection agreement on a product serviced by Sears:

**1-800-827-6655** (U.S.A.)

**1-800-361-6665** (Canada)

---

Para pedir servicio de reparación a domicilio, y para ordenar piezas:

**1-888-SU-HOGAR<sup>®</sup>**

(1-888-784-6427)

Au Canada pour service en français:

**1-800-LE-FOYER<sup>MC</sup>**

(1-800-533-6937)

[www.sears.ca](http://www.sears.ca)

The Sears logo is displayed in a large, stylized, black font. The word "Sears" is written in a cursive-like script with a thick, black underline that curves under the letters. The logo is centered at the bottom of the advertisement.