

**IMPORTANT MANUAL**

**Do Not Throw Away**

**SEARS**

**Operator's  
Manual**

**Model No.  
358.797910**

**▲ WARNING:**

**Read the Operator's Manual and Follow All Warnings and Safety Instructions. Failure To Do So Can Result in Serious Injury.**

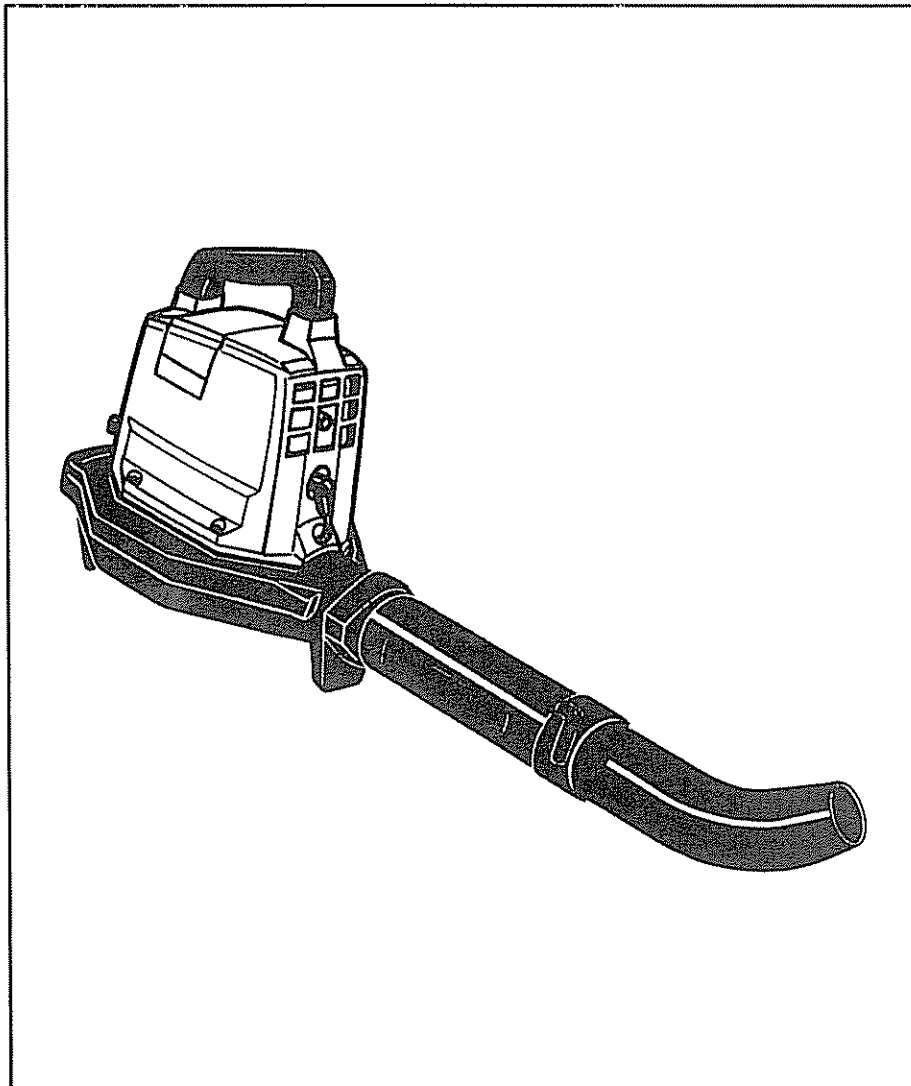

*Always Wear Eye Protection*

**SEARS/CRAFTSMAN®**

**GAS POWER BLOWER**

**2 Cycle Engine**

**Fuel Mix 40:1**

● Assembly

● Maintenance

● Operation

● Repair Parts

Sold by Sears, Roebuck and Co., Hoffman Estates, Ill. 60179 USA

## ONE YEAR LIMITED WARRANTY ON CRAFTSMAN POWER BLOWER

For One Year from date of purchase, when this Power Blower is maintained, lubricated, and tuned up according to the operating and maintenance instructions in the operator's manual, Sears will repair free of charge any defect in material or workmanship.

This warranty excludes blower tubes, spark plug, and air cleaner, which are expendable parts and become worn during normal use.

If this Power Blower is used for commercial or rental purposes, this warranty does not apply.

WARRANTY SERVICE IS AVAILABLE BY RETURNING THE UNIT TO THE NEAREST SEARS SERVICE CENTER/DEPARTMENT IN THE UNITED STATES. This warranty applies only while this product is in use in the United States.

This warranty gives you specific legal rights, and you may also have other rights which vary from state to state.

SEARS, ROEBUCK AND CO./DEPT. D/817WA, HOFFMAN ESTATES, IL 60179

## TABLE OF CONTENTS

<p>WARNINGS AND SAFETY INSTRUCTIONS .. 3</p> <p>KNOW YOUR UNIT ..... 4</p> <p>ASSEMBLY ..... 5</p> <p>USING YOUR UNIT ..... 5</p> <p style="padding-left: 20px;">A. Operator Safety ..... 5</p> <p style="padding-left: 20px;">B. Operating Tips ..... 6</p> <p style="padding-left: 20px;">C. Pre-operation Checks ..... 6</p> <p>FUELING YOUR ENGINE ..... 7</p> <p style="padding-left: 20px;">A. Fueling Information ..... 7</p> <p style="padding-left: 20px;">B. Starting Instructions ..... 7</p> <p style="padding-left: 20px;">C. Carburetor Adjustments ..... 8</p>	<p>GENERAL MAINTENANCE ..... 9</p> <p style="padding-left: 20px;">A. Starter Rope ..... 9</p> <p style="padding-left: 20px;">B. Air Filter ..... 10</p> <p style="padding-left: 20px;">C. Fuel Tank ..... 10</p> <p style="padding-left: 20px;">D. Storage ..... 11</p> <p style="padding-left: 20px;">E. Trouble Shooting Chart ..... 11</p> <p>ACCESSORIES ..... 11</p> <p>REPAIR PARTS LIST ..... 12</p> <p>QUICK REFERENCE PAGE ..... 15</p> <p>PARTS AND SERVICE ..... Back Cover</p>
---	--

## SPECIFICATIONS

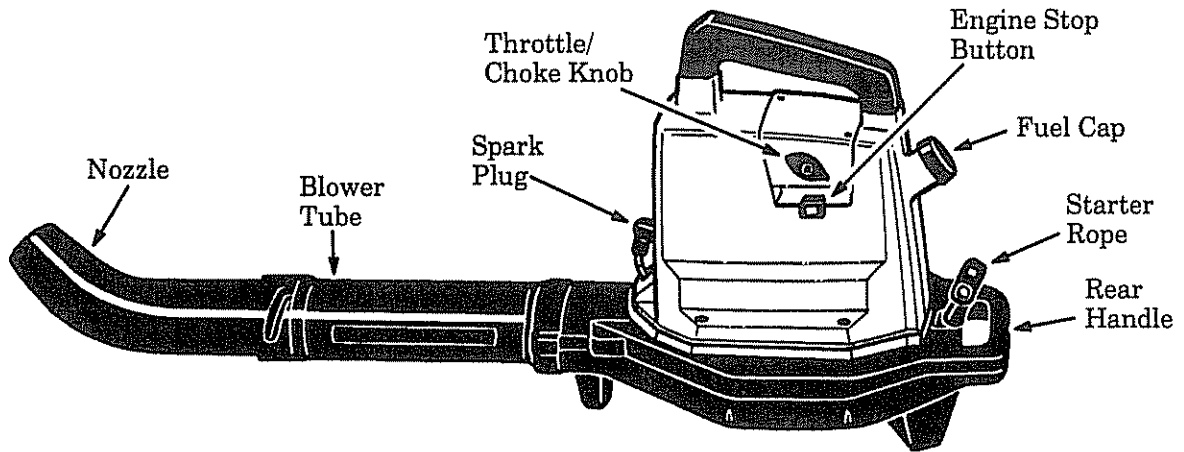

ENGINE TYPE:	2 Cycle Air Cooled	MUFFLER:	Lo Tone
DISPLACEMENT:	22cc	AIR VELOCITY:	140 mph
ENGINE RPM:	Operating-- 7000-7600 Idle-- 3800-4600	AIR VOLUME:	330 cu.ft./min.
IGNITION:	Solid State	SPARK PLUG:	CJ-8Y(Cat. No. 71-85853)
CARBURETOR:	All Position Diaphragm	SPARK PLUG GAP:	.025"
ENGINE STOP BUTTON:	Momentary Kill Switch	MODULE AIR GAP:	.010 - .014 inch
STARTER:	Auto Rewind	LUBRICATION:	Gasoline/Oil Mixture-- See "Fueling Your Engine"
FUEL TANK:	450cc (15.8 fl. oz.)		

Manufactured under one or more of the following U.S. Patents: 4,404,706; 4,413,371; 4,674,146; 4,846,123; D299,074. Other U.S. and foreign patents pending

# WARNINGS AND SAFETY INSTRUCTIONS

*Failure to follow all Safety Rules and Precautions can result in serious injury.*

## A. KNOW YOUR UNIT

1. **Read your Operator's Manual** carefully until you completely understand and can follow all warnings and safety instructions before operating the unit.
2. **Restrict your unit** to users who understand and will follow all warnings and safety instructions in this manual.

## B. PLAN AHEAD

1. **Always wear eye protection** when operating, servicing, or performing maintenance on your unit.
2. **Always wear a respirator or facemask** when working with the unit in dusty environments.
3. **Always wear heavy, long pants, boots, and gloves.** Do not go barefoot or wear short pants, sandals, jewelry, loose clothing, or clothing with loosely hanging straps, ties, tassels, etc.; they can be caught in moving parts. Secure hair so it is above shoulder length. Being fully covered will help protect you from pieces of toxic plants such as poison ivy that can be blown by the unit, which could be more of a hazard than touching the plant itself.
4. **Do not operate the unit** when you are tired, ill, upset, or if you are under the influence of alcohol, drugs, or medication.
5. **Keep children, bystanders, and animals away** from the work area a minimum of 30 feet when starting or operating the unit.
6. **Inspect the area before starting the unit.** Remove all debris and hard objects such as rocks, glass, wire, etc. that can ricochet, be thrown, or otherwise cause injury or damage during operation.
7. **Do not operate the unit near an open flame.** Do not blow ash from fireplaces, barbecue pits, brush piles, etc., or anything that is burning or smoking, such as cigars, cigarettes, or matches.

## C. HANDLE FUEL WITH CAUTION

1. **Eliminate all sources of sparks or flame** (including smoking, open flames, or work that can cause sparks) in the areas where fuel is mixed, poured, or stored.
2. **Mix and pour fuel in an outdoor area;** store fuel in a cool, dry, well-ventilated place; use an approved, marked container for all fuel purposes.
3. **Do not smoke while handling fuel or while operating the unit.**
4. **Do not fill fuel tank while engine is running.**
5. **Wipe up all fuel spills** before starting engine.
6. **Move at least 10 feet away from fuel and fueling site** before starting the engine.

## D. OPERATE YOUR UNIT SAFELY

1. **Inspect the entire unit** before each use for worn, loose, missing, or damaged parts. Do not use until the unit is in proper working order.
2. **Keep the outside surfaces free of oil and fuel.**

3. **Never start or run engine inside a closed room or building.** Breathing exhaust fumes can kill.
4. **Do not set the unit on any surface except a clean, hard area to start the engine or while the engine is running.** Debris such as gravel, sand, dust, grass, etc. could be picked up by the air intake and thrown out through the discharge opening, damaging the unit, property, or causing serious injury to bystanders or the operator.
5. **Avoid dangerous environments.** Do not use in unventilated areas or where explosive vapors or carbon monoxide build up could be present.
6. **Do not overreach or use from unstable surfaces** such as ladders, trees, steep slopes, rooftops, etc. Use extra care when using on stairways. Keep firm footing and balance at all times.
7. **Never place objects inside the blower tubes;** always direct the blowing debris away from people, animals, glass, and solid objects such as trees, automobiles, walls, etc. The force of air can cause rocks, dirt, or sticks to be thrown or to ricochet which can hurt people or animals, break glass, or cause other damage. Do not allow the unit to be used as a toy.
8. **Never place any object in the air intake opening** as this could restrict proper air flow and cause damage to the unit.
9. **Never run the engine without the blower tubes attached.**
10. **Never use for spreading chemicals, fertilizers,** or any other material which may contain toxic substances.
11. **Use only for jobs explained in this manual.**

## E. MAINTAIN YOUR UNIT PROPERLY

1. **Have all maintenance** other than the recommended procedures described in the Operator's Manual performed by your Sears Service Center.
2. **Disconnect spark plug before performing maintenance** except for carburetor adjustment.
3. **Use only genuine replacement parts** as recommended by Sears to avoid creating a hazard and/or voiding your warranty.
4. **Check air intake openings and blower tubes frequently,** always with the engine stopped. Keep vents and tubes free of debris which can accumulate and restrict proper air flow.
5. **Before storing the unit, use up any fuel remaining in the fuel system.** Use up fuel left in the fuel lines and carburetor by starting the engine and letting it run until it stops.
6. **Do not use any accessory or attachment** other than those recommended by Sears for use with your unit.
7. **Do not store the unit or fuel in a closed area** where fuel vapors can reach sparks or an open flame from hot water heaters, electric motors or switches, furnaces, etc.
8. **Store in a dry area out of the reach of children.**

### **SPECIAL NOTICE**

For users on U.S. Forest Land and in some states, including California (Public Resources Codes 4442 and 4443), Idaho, Maine, Minnesota, New Jersey, Oregon, and Washington: Certain internal combustion engines operated on forest, brush, and/or grass-covered land in the above areas are required to be equipped with a spark arrestor, maintained in effective working order, or the engine must be constructed, equipped, and maintained for the prevention of fire. Check with your state or local authorities for regulations pertaining to these requirements. Failure to follow these requirements is a violation of the law. **This unit is not factory-equipped with a spark arrestor;** however, a spark arrestor is available as an optional part. If a spark arrestor is required in your area, contact your Sears Service Center or Parts Department for Spark Arrestor kit #530-069285.

# KNOW YOUR UNIT

## A. INTRODUCTION

Your blower is a high performance product designed for tough jobs.

### Special Features include:

- Top handle for one-handed operation.
- Vibration-dampened handle.
- Weight - 10.5 lbs.
- Convenient upright storage.
- Available gutter attachment kit.
- Rear assist handle.

KEY NO.	CARTON CONTENTS	QTY.
1.	Engine/Blower	1
2.	Blower Tube	1
3.	Nozzle	1
4.	2-cycle Engine Oil	1
-	Operator's Manual (not shown)	1
-		

## B. UNPACKING INSTRUCTIONS

1. Remove contents from the carton if you have not done so.
2. Check parts against the carton contents list.
3. Examine parts for damage. Do not use damaged parts.
4. *Notify your Sears Service Center/Department immediately if a part is missing or damaged.*

**NOTE:** It is normal to hear the fuel filter rattle in an empty fuel tank.

**NOTE:** Your unit is factory equipped with a vibration-dampened handle which causes the handle to appear to be loose. This condition is normal. See the Safety Notice at the bottom of this page.

**NOTE:** Your unit has been factory tested and the carburetor precisely adjusted. Therefore, it is possible to smell gasoline or to find a drop of oil/fuel residue on the muffler.

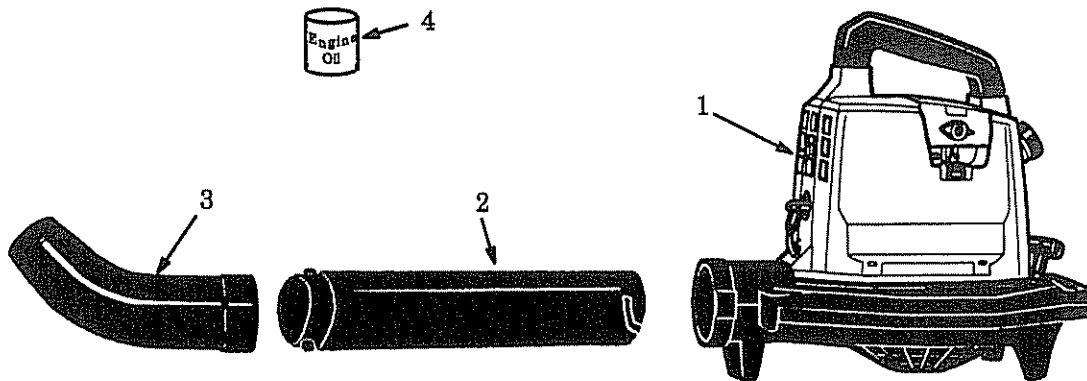

**NOTE:** Illustration may differ from actual model due to design changes.

### SAFETY NOTICE

Exposure to vibrations through prolonged use of gasoline powered hand tools could cause blood vessel or nerve damage in the fingers, hands, and wrists of people prone to circulation disorders or abnormal swellings. Prolonged use in cold weather has been linked to blood vessel damage in otherwise healthy people. If symptoms occur such as numbness, pain, loss of strength, change in skin color or texture, or loss of feeling in the fingers, hands, or wrists, discontinue the use of this tool and seek medical attention. An anti-vibration system does not guarantee the avoidance of these problems. Users who operate power tools on a continual and regular basis must monitor closely their physical condition and the condition of this tool.

# ASSEMBLY

## A. PREPARATION

Your Operator's Manual has been developed to help you assemble the unit and to understand its safe operation. It is important that you read your manual completely to become familiar with the unit *before* you begin assembly.

### READ YOUR OPERATOR'S MANUAL.

**NOTE:** To ease assembly, lubricate locking tabs before assembling tubes.

## B. BLOWER TUBE ASSEMBLY

1. Locate the two Locking Tabs on the side of the Blower Tube. Figure 1.
2. Align the Grooves on the Nozzle with the Locking Tabs on the Blower Tube and push the Nozzle onto the Blower Tube.
3. Turn the Nozzle clockwise until the parts snap into place and are firm and tight.
4. Align Grooves on the Blower Tube with Locking Tabs in the Blower Outlet (Figure 1, inset) and push the Blower Tube into the Blower Outlet.

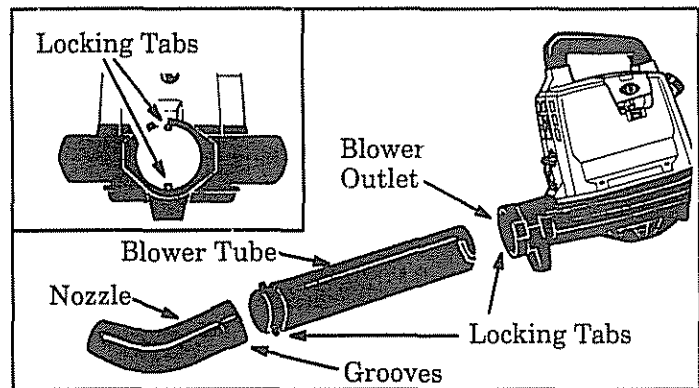

Figure 1

5. Turn the Blower Tube clockwise until the parts snap into place. When assembled, the nozzle should be aligned as shown in Figure 2.

# USING YOUR UNIT

## A. OPERATOR SAFETY

The unit is designed to sweep debris, grass, straw, leaves, small twigs, or light snow. It can also be used for fast drying wet outdoor areas such as a patio, sidewalk, carport, etc. Never use for spreading or misting chemicals, fertilizers, or any other materials which may contain toxic substances.

1. **Read your Operator's Manual.** Make sure you completely understand and can follow all warnings and safety instructions in the manual *before* operating the unit.
2. **Always wear eye protection** when operating, servicing, or performing maintenance on your unit.
3. **Always wear a respirator or facemask** when working in dusty environments.
4. **Always wear heavy, long pants, boots, and gloves.** Do not go barefoot or wear short pants, sandals, jewelry, loose clothing, or clothing with loosely hanging straps, ties, tassels, etc.. Secure hair so it is above shoulder length. Being fully covered will help protect you from pieces of toxic plants such as poison ivy that can be blown by the unit, which could be more of a hazard than touching the plant itself.
5. **Check the unit before each operation.** Look for worn, loose, missing, or damaged parts. Do not use the unit until it is in proper working order.
6. **Inspect area before starting engine.** Remove all debris and objects such as rocks, glass, wire, large sticks, etc that can cause damage during operation.
7. **Keep children, bystanders, and animals safely away.** *Before starting the engine and during operation, make certain children, people, and animals are a minimum of 30 feet away from the work area.*
8. **Do not operate near an open flame.** Do not blow ash from fireplaces, barbecue pits, brush piles, etc., or anything that is burning or smoking, such as cigars, cigarettes, or matches.
9. **Never run the unit without the blower tubes attached.**
10. **Check air intake opening and blower tubes frequently,** always with the engine stopped and

the spark plug disconnected. Keep vents and discharge tubes free of debris which can accumulate and restrict proper air flow.

11. **Use the correct operating position.** Figure 2. Do not overreach or use from unstable surfaces such as ladders, trees, steep slopes, roof tops, etc. Use extra care when cleaning on stairways. Keep firm footing and balance at all times.
12. **Never place objects inside the blower tubes;** always direct blowing debris away from people, animals, glass, and solid objects such as trees, automobiles, walls, etc. The force of air can cause rocks, dirt, or sticks to be thrown or to ricochet which may hurt people or animals, break glass, or cause other damage. Do not allow unit to be used as a toy.
13. **Do not set the unit on any surface except a clean, hard area to start the engine or while the engine is running.** Debris such as gravel, sand, dust, grass, etc. could be picked up by the air intake and thrown out through the discharge opening, damaging the unit, property, or causing serious injury to bystanders or the operator.

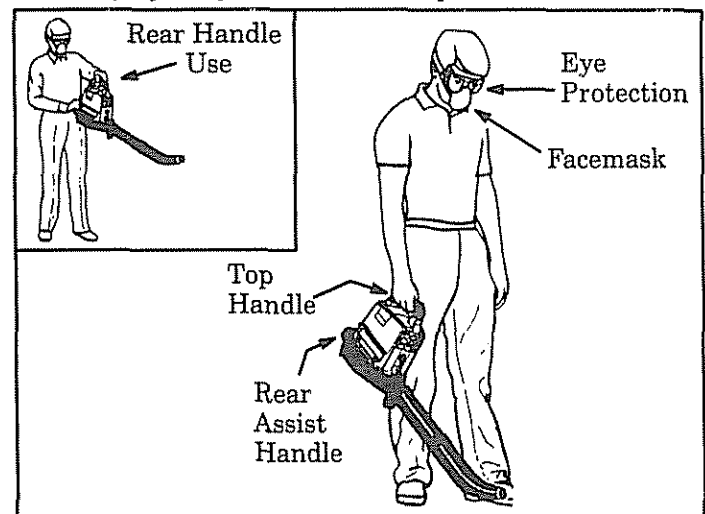

Figure 2

---

## B. OPERATING TIPS

### ▲ WARNING

Do not use the unit without the blower tubes properly attached to avoid flying debris and/or impeller contact which can cause serious injury.

1. Always work going away from solid objects such as walls, large stones, automobiles and fences.
2. Do not operate unit at full throttle when cleaning in corners. Clean corners by starting in corners and moving outward to straight areas to prevent an accumulation of debris which could fly into face.
3. Be careful when working near plants. The force of the air could damage tender plants.
4. Direct air flow by directing the nozzle down or to one side.
5. Vary the air flow by turning the Throttle Knob to the desired setting. Use low speed when blowing in corners, against walls, around tender plants, in extremely dusty areas, etc. Use high speed when blowing in open areas.

### ▲ WARNING

Always wear eye protection to prevent rocks or debris from being blown or ricocheting into the eyes and face which can result in blindness or serious injury.

6. Use the assist handle located on the back of the unit when working above the waist or when a two-handed grip is desired.
7. Uses For Your Blower:
  - a. Sweeping debris or grass clippings from driveways, sidewalks, patios, parks, parking lots, barns, stadiums, etc.
  - b. Blowing grass clippings, straw, or leaves into piles.
  - c. Fast drying wet outdoor areas such as a patio.
  - d. Removing debris from corners, around joints, and between bricks.
  - e. Blowing light snow from driveways, sidewalks, or patios.

---

## C. PRE-OPERATION CHECKS

Before operating your unit, always:

1. ✓CHECK OVER WARNINGS AND SAFETY INSTRUCTIONS in this Operator's Manual. Make certain you completely understand and follow each one.
2. ✓CHECK THE AIR FILTER.  
Clean the filter if dirty before operating the unit. For location, see the "Air Filter" section.

3. ✓CHECK THE UNIT FOR LOOSE BOLTS, NUTS, OR FITTINGS.  
Tighten, repair, or replace parts as necessary. You will need a Phillips screwdriver and a  $\frac{5}{32}$  hex wrench. Use only genuine replacement parts as recommended by Sears.
4. ✓CHECK THE FUEL TANK.  
Fill with a clean, fresh fuel mixture according to the instructions in the "Fuel Mixture" section.

---

## NOTES

# FUELING YOUR ENGINE

## A. FUELING INFORMATION

### 1. FUEL SAFETY

- Use only recommended fuel mixtures.
- Mix and pour fuel outdoors and where there are no sparks or flames.
- Use a container approved for fuel.
- Do not smoke or allow smoking near fuel or the unit or while using the unit.
- Wipe up all fuel spills before starting the engine.
- Move at least 10 feet away from fueling site before starting engine.
- Stop engine before removing fuel cap.
- Before storing the unit, use up fuel left in the fuel lines and carburetor by starting the engine and letting it run until it stops.
- Store unit and fuel in an area where fuel vapors cannot reach sparks or open flames from water heaters, electric motors or switches, furnaces, etc.
- Always remove the fuel cap slowly to relieve pressure in the fuel tank.

### 2. FUEL MIXTURE

- Your unit is powered by a 2-cycle engine which requires a fuel mixture of regular unleaded gasoline and a high quality engine oil specially made for 2-cycle, air cooled engines. The internal design of the 2-cycle engine requires lubrication of moving parts. Lubrication is provided when recommended mixture of gasoline and oil is used.
- Gasoline must be clean and fresh. After a short period of time, gasoline will chemically break down and form compounds that cause hard starting and damage in 2-cycle engines.
- The correct measure of gasoline to oil is very important. Too much oil in the mixture will foul the spark plug.

**CAUTION:** Too little oil will cause the engine to overheat and seize.

### 3. USE THE FOLLOWING ONLY:

SEARS CRAFTSMAN 2-cycle engine oil mixed at 40:1 is strongly recommended. Consult the instructions on the oil container for proper mixing.

1 PART OIL TO 40 PARTS GASOLINE =  
3.2 fl. oz. oil to 1 gallon gasoline  
8.0 fl. oz. oil to 2.5 gallon gasoline

Not all air cooled 2-cycle engine oils have the same qualities. If SEARS CRAFTSMAN 2-cycle engine oil is not available, use a good quality, 2-cycle engine oil recommended for air-cooled engines. Mix at a ratio of 16:1 (8 oz. oil to 1 gallon gasoline). A 16:1 fuel mixture with these oils will assure adequate lubrication for your engine.

### 4. DO NOT USE:

- NMMA Oil**—National Marine Manufacturers Association (formerly BIA)  
Does not have proper additives for air-cooled, 2-cycle engines and can cause engine damage.
- AUTOMOTIVE OIL**—  
Does not have proper additives for air-cooled, 2-cycle engines and can cause engine damage.

#### ▲ CAUTION

Experience indicates that alcohol blended fuels (called gasohol or using ethanol or methanol) can attract moisture which leads to separation and formation of acids during storage. Acidic gas can damage the fuel system of an engine while in storage. To avoid engine problems, do not leave fuel in the unit when storing for 30 days or longer. Start the engine and let it run until the fuel lines and carburetor are empty. Use fresh fuel next season. See the "Storage" section for additional information. Never use engine or carburetor cleaner products in the fuel tank or permanent damage can occur.

### 5. HOW TO MIX FUEL AND FILL TANK

- Pour the proper measure of engine oil into an approved, marked container. Then, fill the container with regular unleaded gasoline.  
**NOTE:** If fuel is already in the container, add the proper measure of engine oil. Then, close the container tightly and shake it momentarily.  
**NOTE:** Do not mix gasoline and oil directly in the fuel tank.
- Using a spout or funnel, fill the fuel tank with fuel mix.
- Reinstall the fuel caps securely.

## B. STARTING INSTRUCTIONS

### 1. Before Starting the Engine:

- Fuel the engine; then, move at least 10 ft. (3 m) away from the fueling site.
- Hold unit in the starting position shown in Figure 3. Make sure blower nozzle is directed away from people, animals, glass, and solid objects.

#### ▲ WARNING

When starting engine, hold the unit as shown in Figure 3. Do not set the unit on any surface except a clean, hard area while starting or running the engine. Debris such as gravel, sand, dust, grass, etc., could be picked up by the air intake and thrown out through the discharge opening, damaging the unit or property, or causing serious injury to bystanders or the operator.

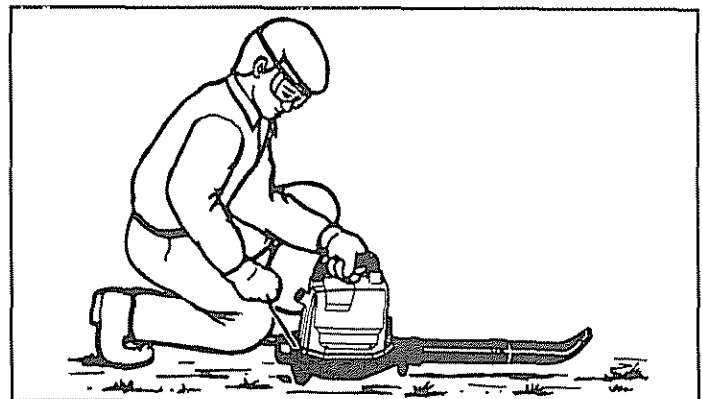

Figure 3

## 2. For a Cold Engine:

- a. Set the unit on a clean, hard surface.
- b. Turn Throttle Knob to the "FULL CHOKE" position. Figure 4.
- c. Pull Starter Rope sharply until engine attempts to run, but no more than 8 pulls on full choke. **The engine "attempts to run" may be hard to hear. The operator must listen carefully.** After 8 pulls, proceed to step "d." even if the engine has not attempted to run.
- d. Turn Throttle Knob to the "HALF CHOKE" position. Figure 4.
- e. Pull Starter Rope sharply until engine runs, but no more than 5 pulls.

**NOTE:** If engine has not started after 5 pulls in the "HALF CHOKE" position, repeat steps "a" through "e."

- f. Allow engine to run for 10 seconds in the "HALF CHOKE" position, then turn the Throttle Knob to the "FULL THROTTLE" position.

**NOTE:** If engine dies, repeat steps "d." through "f." If engine does not operate properly, refer to the "Carburetor Adjustments" section.

- g. To stop engine, turn Throttle Knob to the "IDLE" position. Then, press and hold the "STOP" switch until the engine stops. Figure 4.

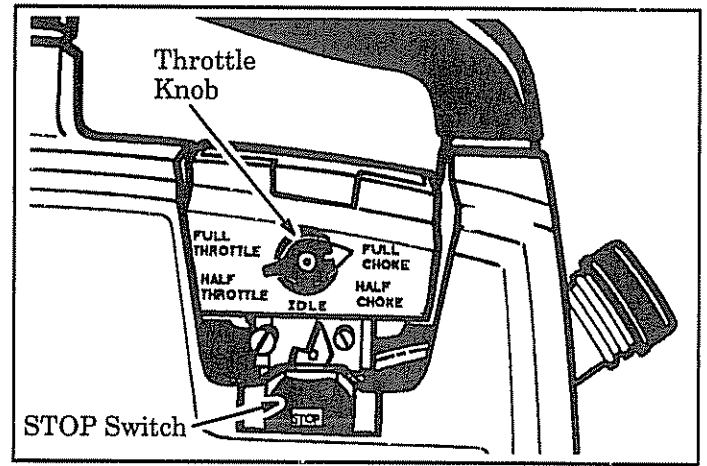

Figure 4

## 3. For a Warm Engine or a Warm Engine After Running Out of Fuel:

- a. Turn Throttle Knob to the "HALF CHOKE" position. Figure 4.
- b. Pull the Starter Rope sharply until the engine runs, but no more than 3 pulls.

**NOTE:** If the engine does not run after 3 pulls in the "HALF CHOKE" position, repeat steps "a." through "e." for Cold Engine starting.

- c. Turn the Throttle Knob to the desired position.
- d. To stop engine, turn Throttle Knob to the "IDLE" position. Then, press and hold the "STOP" switch until the engine stops. Figure 4.

## C. CARBURETOR ADJUSTMENTS

- **Poor engine performance can be a result of other causes** such as a dirty air filter, carbon build-up on the muffler outlets, etc. See the "Trouble Shooting Chart" before proceeding with carburetor adjustments.
- **The carburetor has been carefully adjusted at the factory.** Due to changes in altitude and operating conditions, your carburetor may require adjusting. To make the adjustment, carefully follow the procedure below.

### 1. PREPARATION

- a. Use fresh fuel mix. See the "Fueling Your Engine" section.
- b. Turn the Mixture Screw (Figure 5) clockwise until fully closed, but do not over-tighten. Figure 5. Then, turn it one full turn counterclockwise.
- c. Turn Idle Speed Screw (Figure 5) clockwise until it stops. Do not overtighten. Then, turn it three full turns counterclockwise.

### 2. IDLE SPEED ADJUSTMENT

- a. Start the unit and let it run for 3 minutes to warm up the engine.
- b. Position the Throttle Knob to the "IDLE" position.
- c. Adjust Idle Speed Screw until the engine idles as slowly as possible without stalling.
  - Turn screw clockwise if engine stalls.
  - Turn screw counterclockwise to slow engine down.

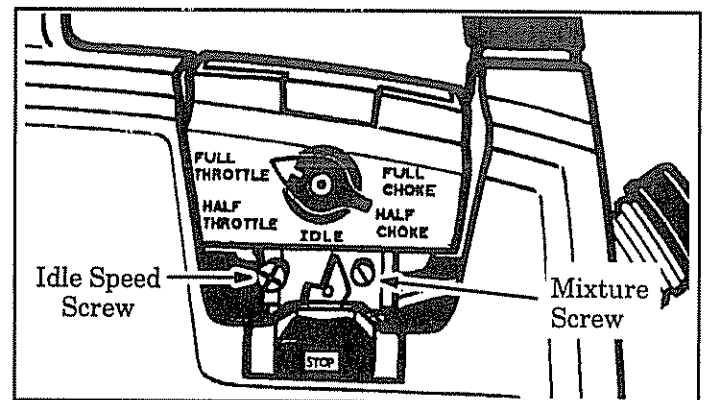

Figure 5

**CAUTION:** The mixture setting is a highly critical adjustment. If set incorrectly, permanent damage to the engine will occur. Do not operate engine at full throttle for prolonged periods while making the mixture adjustment.

### 3. MIXTURE ADJUSTMENT:

- a. Position the throttle knob to the "FULL THROTTLE" position.
- b. Turn the mixture screw **slowly** clockwise until engine speed is reduced. Note this position.
- c. Turn the screw **slowly** counterclockwise. Stop when the engine begins to run roughly.
- d. Turn screw **slowly** the **minimum amount** clockwise until the engine runs smoothly.

**NOTE:** Turning the mixture screw too far clockwise will result in poor acceleration and poor starting.



# GENERAL MAINTENANCE

## A. STARTER ROPE

Replace the starter rope if the rope breaks or is badly worn.

**NOTE:** When replacing an unbroken rope, cut the rope and allow the rope to rewind onto the pulley.

### ▲ WARNING

Do not remove the Pulley when replacing the starter rope. Always wear eye protection when servicing the starter rope. The recoil spring, located beneath the pulley, is under tension. If the spring pops out, serious injury can result.

To repair or replace:

1. Disconnect the spark plug wire from the spark plug.
2. Set the unit on a flat surface as shown in Figure 6.
3. Remove the Pulley Housing Screws and the Pulley Housing from the Engine. Figure 6.
4. Grasp the Pinion [Figure 7 (inset)] and wind the pulley clockwise until the Pulley stops. Then, slowly unwind the pulley counterclockwise until the Pulley Notch (Figure 7) is aligned with the notch in the Pulley Housing. Insert a screwdriver into the hole formed by the aligned notches. Figure 7.
5. Remove the Rope Retainer Screw/Washer. Figure 7. Discard any remaining rope.
6. Move away from fuel tank and melt ends of rope.
7. Allow each melted end to drip once; then while the rope is still hot, pull each melted end through a clean rag to obtain a smooth, pointed end.
8. Insert one end of the rope through the starter handle and secure with a knot. Leave 3/16" pigtail behind the knot. Figure 6 (Inset).
9. Insert the other end of the rope through the Metal Eyelet, then over the Rope Guide. Figure 6.
10. Guide rope inside the pulley, then up through the Pulley Hole. Figure 7 (Inset).
11. Wrap rope counterclockwise around Helix and tuck the loose end back under the rope. Figure 7. Leave about a 1 inch tail next to the Retainer Rib as shown in Figure 7.

**NOTE:** When performing step 12., do not overtighten the Retainer Screw. Overtightening the screw can cause the screw post to strip out. Tighten the screw until the bottom of the washer is snug against the rope.

12. Install and tighten Rope Retainer Screw/Washer.
13. Pull the rope tightly around the Helix.
14. Slightly pull the rope to relieve the pressure on the screwdriver. Remove the screwdriver and allow the rope to rewind slowly.

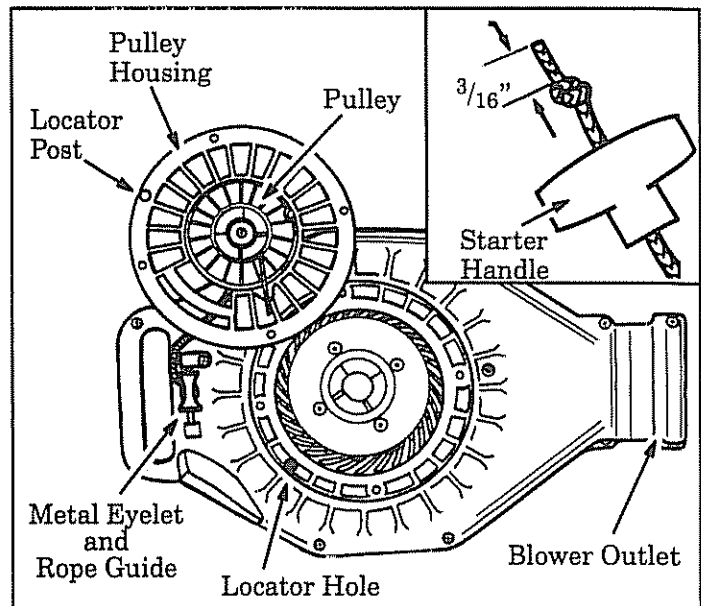

Figure 6

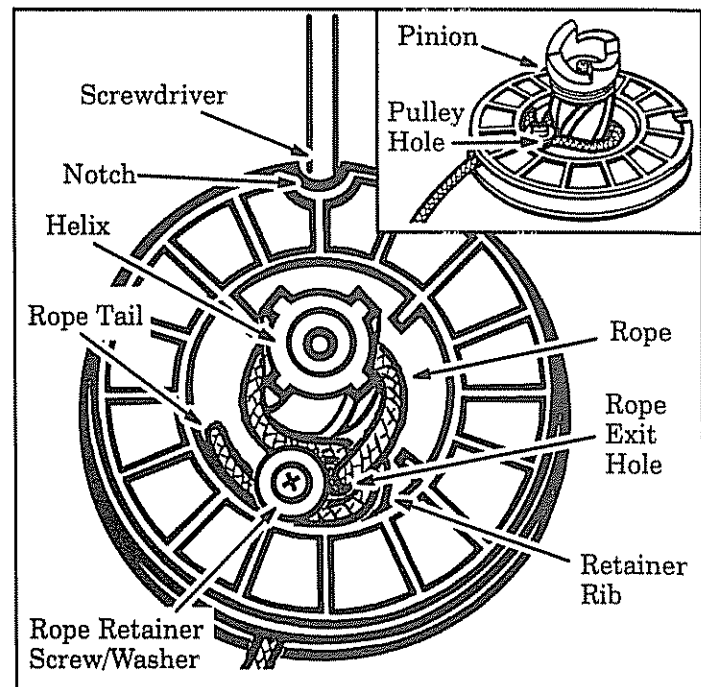

Figure 7

**NOTE:** When performing step 15., be sure not to overtighten the screws. Overtightening the screws can strip-out the Fan Housing.

15. Align the locator post on the pulley housing with the locator hole on the fan housing. Figure 6. Reassemble the Pulley Housing to the engine. Tighten screws securely.

## B. Air Filter

A dirty air filter decreases engine performance and increases fuel consumption.

### Clean the Air Filter:

- Frequently,
- **Always clean after 5 tanks of fuel or 5 hours of operation, whichever is less.**

Follow these steps:

1. Turn Throttle Knob to the "FULL CHOKE" position. Figure 4.
2. Remove the Air Filter Cover Screws and Air Filter Cover on top of the unit. Figure 8.
3. Remove the Air Filter. Figure 8 (inset).
4. Wash the Air Filter with soap and water.

**CAUTION:** Do not clean filter in gasoline or other flammable solvent to avoid creating a fire hazard.

5. Squeeze the Air Filter dry.
6. Add 4 or 5 drops of oil to the the Air Filter.

**NOTE:** Avoid soaking the Air Filter with oil.

7. Squeeze the Air Filter to distribute oil.
8. Reinstall Air Filter and Air Filter Cover. Figure 8.

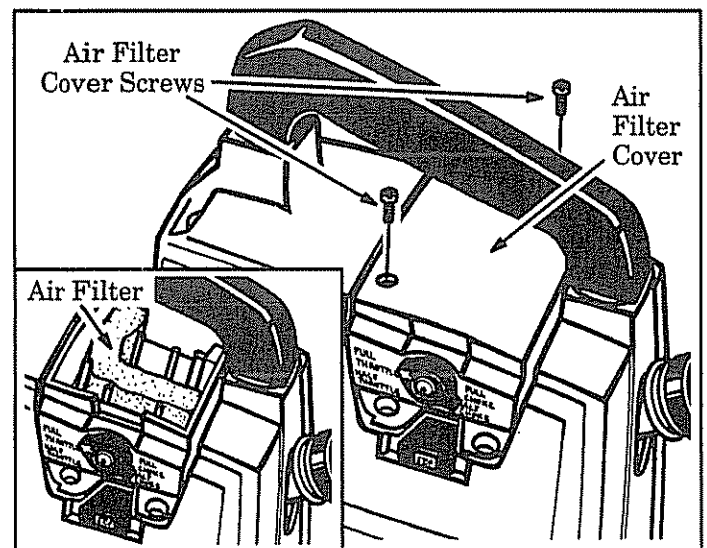

Figure 8

## C. FUEL TANK

1. **Never use gasoline that is more than 2 months old in a fuel mixture.** Gasoline begins to break down after a short period of time and will form compounds that cause hard starting and damage in 2-cycle engines.

**NOTE:** *Using a fuel mix or gasoline over 2 months old will cause the engine to be difficult or impossible to start.*

2. **Inspect the unit for fuel leaks each time it is used.** Repair or replace parts as necessary.
3. **Do not leave fuel in the unit when storing for 30 days or longer.** Use up fuel left in the fuel lines and carburetor by starting the engine and letting it run until it stops.

## D. STORAGE

1. **Clean the unit before storing.** Pay particular attention to the air intake area, keeping it free of debris. Use a mild detergent and sponge to clean the plastic surfaces.
2. **Do not store the unit or fuel in a closed area** where fuel vapors can reach sparks or an open flame from hot water heaters, electric motors or switches, furnaces, etc.
3. **Store unit in a dry area out of the reach of children.**
4. **Do not leave fuel in the unit when storing for 30 days or longer.** Use up fuel left in the fuel lines and carburetor by starting the engine and letting it run until it stops.

**NOTE:** If you do not want to remove the gasoline from your unit, SEARS CRAFTSMAN Fuel Stabilizer (#71-33500) may be added to gasoline left in the tank to minimize gum deposits and acids. If the tank is almost empty, mix stabilizer with fresh gasoline in a separate container and add to tank.

ALWAYS FOLLOW INSTRUCTIONS ON THE STABILIZER CONTAINER. THEN, RUN THE ENGINE AT LEAST 2 MINUTES AFTER STABILIZER IS ADDED TO ALLOW MIXTURE TO REACH CARBURETOR. STORE UNIT IN A SAFE PLACE. SEE STEP 2 (this section).

### ⚠ WARNING

It is important to prevent gum deposits from forming in essential fuel system parts such as the carburetor, fuel filter, fuel hose, or fuel tank during storage. Experience indicates that alcohol blended fuels (called Gasohol or using ethanol or methanol) can attract moisture which leads to separation and formation of acids during storage. Acidic gas can damage the fuel system of an engine while in storage.

## E. TROUBLE SHOOTING CHART

TROUBLE	CAUSE	REMEDY
Engine will not start.	<ol style="list-style-type: none"> <li>1. Fuel tank empty.</li> <li>2. Spark plug not firing.</li> <li>3. Fuel not reaching carburetor.</li> <li>4. Engine flooded.</li> <li>5. Compression low.</li> <li>6. Ignition module.</li> </ol>	<ol style="list-style-type: none"> <li>1. Fill tank with correct fuel mixture.</li> <li>2. Install new spark plug.</li> <li>3. Check for dirty fuel filter; clean. Check for kinked or split fuel line; repair or replace.</li> <li>4. See "Starting Instructions."</li> <li>5. Contact your Service Center.</li> <li>6. Contact your Service Center.</li> </ol>
Engine will not idle properly.	<ol style="list-style-type: none"> <li>1. Idle speed set too low.</li> <li>2. Idle speed set too high.</li> <li>3. Mixture screw requires adjustment.</li> <li>4. Crankshaft seals worn.</li> <li>5. Compression low.</li> </ol>	<ol style="list-style-type: none"> <li>1. Adjust idle speed screw clockwise to increase speed.</li> <li>2. Adjust idle speed screw counterclockwise to reduce speed.</li> <li>3. See "Carburetor Adjustments."</li> <li>4. Contact your Service Center.</li> <li>5. Contact your Service Center.</li> </ol>
Engine will not accelerate, lacks power, or dies under a load.	<ol style="list-style-type: none"> <li>1. Carburetor requires adjustment.</li> <li>2. Air filter dirty.</li> <li>3. Spark plug fouled.</li> <li>4. Carbon build-up.</li> <li>5. Compression low.</li> </ol>	<ol style="list-style-type: none"> <li>1. See "Carburetor Adjustments."</li> <li>2. Clean or replace air filter.</li> <li>3. Clean or replace spark plug and regap.</li> <li>4. Contact your Service Center.</li> <li>5. Contact your Service Center.</li> </ol>
Engine smokes excessively.	<ol style="list-style-type: none"> <li>5. Choke partially on.</li> <li>6. Air filter dirty.</li> <li>7. Mixture screw requires adjustment.</li> <li>8. Fuel mixture incorrect.</li> </ol>	<ol style="list-style-type: none"> <li>1. Adjust choke.</li> <li>2. Clean or replace air filter.</li> <li>3. See "Carburetor Adjustments."</li> <li>4. Empty fuel tank and refill with correct fuel mixture.</li> </ol>
Engine runs hot.	<ol style="list-style-type: none"> <li>1. Fuel mixture incorrect.</li> <li>2. Spark plug incorrect.</li> <li>3. Carbon build-up.</li> <li>4. Mixture screw set too low.</li> </ol>	<ol style="list-style-type: none"> <li>1. See "Fueling Your Unit."</li> <li>2. Replace with correct spark plug.</li> <li>3. Contact your Service Center.</li> <li>4. See "Carburetor Adjustments."</li> </ol>

---

## ACCESSORIES

---

The following accessories are available through Sears Retail Stores, Catalog Outlets, or Service Centers.

<u>ITEM</u>	<u>STOCK NO.</u>
Safety Goggles .....	71-85707
Gutter Attachment Kit .....	71-79992
2-Cycle Engine Oil .....	71-36551
Fuel Stabilizer .....	71-33500
Spark Plug .....	71-85853
Spark Arrestor .....	530-069285*
Operator's Manual .....	530-067870*

\* Available through your SEARS Service Center/Catalogue.

# SEARS GAS BLOWER REPAIR PARTS LIST – MODEL 358.797910

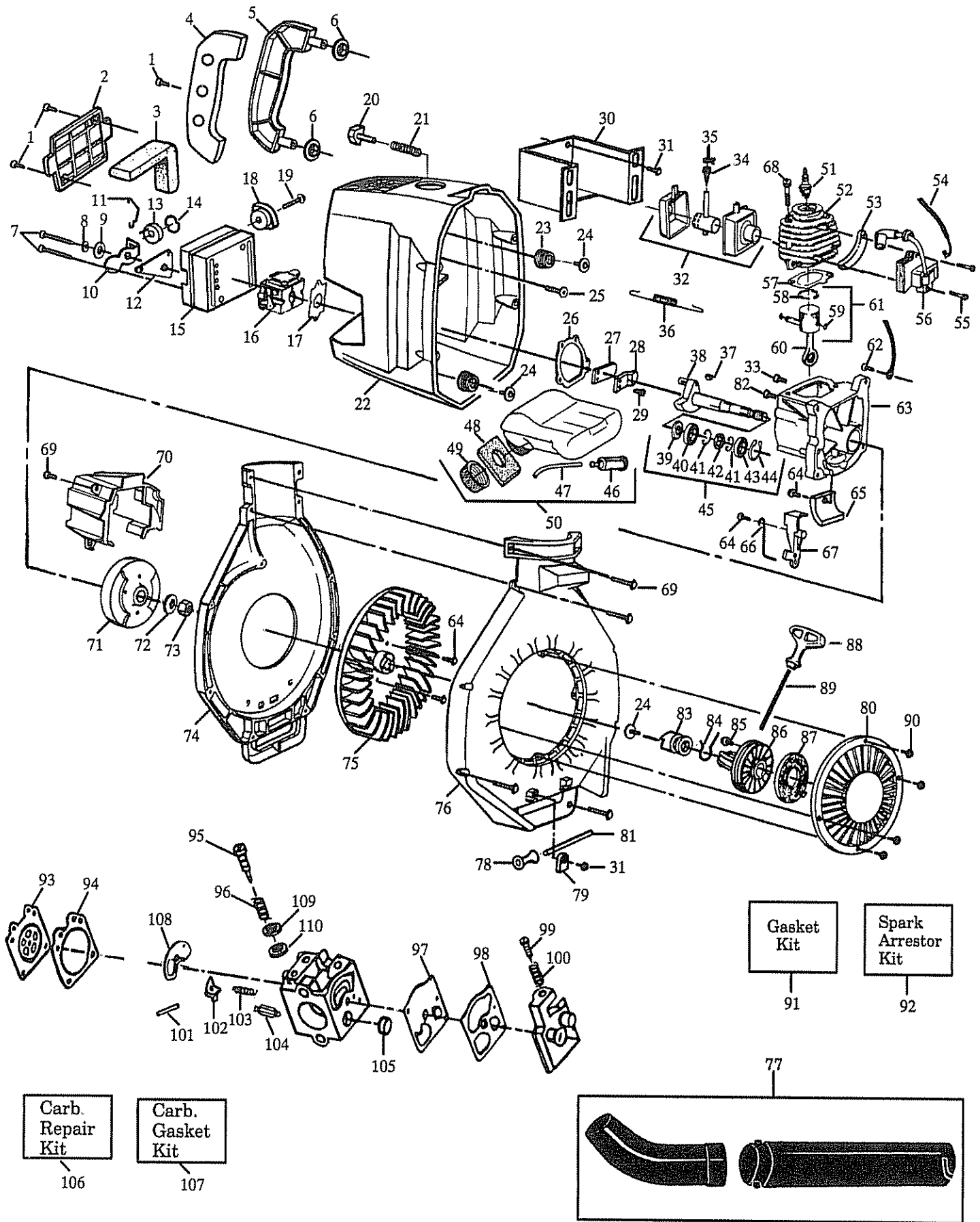

# SEARS GAS BLOWER REPAIR PARTS LIST – MODEL 358.797910

Key No.	Part No.	Description	Key No.	Part No.	Description
1	530-015635	Screw	64	530-015918	Screw
2	530-029489	Air Filter Cover	65	530-029603	Isolator
3	530-029611	Air Filter	66	530-029613	Spring
4	530-029615	Handle Cover	67	530-029601	Insulator
5	530-029614	Handle	68	530-015239	Screw
6	530-029608	Handle Isolator	69	530-015872	Screw
7	530-015887	Screw	70	530-029433	Baffle
8	530-015852	Choke Spacer	71	530-039139	Flywheel
9	530-015254	Wave Washer	72	530-015149	Washer
10	530-029480	Choke Shutter	73	530-626605	Nut
11	530-029485	Throttle Wire	74	530-029432	Blower Housing (Upper)
12	530-029481	Choke Mtg. Plate	75	530-094865	Impeller
13	530-029486	Retainer	76	530-014265	Blower Housing (Lower)
14	530-015147	Wave Washer (Knob)	77	530-069271	Blower Tube Kit
15	530-029588	Air Box	78	530-029575	Roller
16	530-035290	Carburetor (WA-207A)	79	530-027523	Retainer
17	530-019164	Carburetor Gasket	80	530-094867	Pulley Housing
18	530-029484	Throttle Knob	81	530-015851	Roll Pin
19	530-015880	Screw	82	530-015772	Screw
20	530-029600	Button	83	530-029448	Pinion
21	530-029607	Spring	84	530-029449	Drag Element
22	530-029565	Shroud	85	530-015882	Screw
23	530-029434	Spring	86	530-069306	Starter Pulley
24	530-015879	Screw	87	530-027531	Starter Spring
25	530-015876	Screw	88	530-027569	Starter Handle
26	530-019154	Gasket	89	530-069232	Rope Kit
27	530-027593	Reed Valve	90	530-015886	Screw
28	530-029781	Reed Stop	91	530-069302	Gasket Kit
29	530-015241	Screw	92	530-069348	Spark Arrestor Kit
30	530-029597	Heat Shield	93	530-035014	*+ Metering Diaphragm
31	530-015805	Screw	94	530-035151	*+ Metering Diaphragm Gasket
32	530-069293	Muffler	95	530-035212	Mixture Needle
33	530-015771	Screw	96	530-035214	Mixture Needle Spring
34	530-029227	Spark Arrestor Screen	97	530-035166	*+ Fuel Pump Diaphragm
35	530-029228	Spark Arrestor Clamp	98	530-035164	*+ Fuel Pump Gasket
36	530-029116	Muffler Spring	99	530-035203	Idle Speed Screw
37	530-015126	Key	100	530-035208	Idle Speed Spring
38	530-010945	Crankshaft Ass'y.	101	530-035028	* Metering Lever Pin
39	530-015788	Spacer	102	530-035031	* Metering Lever
40	530-032103	Inner Bearing	103	530-035188	* Metering Lever Spring
41	530-015787	Ring	104	530-035106	* Inlet Needle Valve
42	530-019158	Crankshaft Seal	105	530-035178	* Fuel Inlet Screen
43	530-032102	Outer Bearing	106	530-035260	Carb. Kwik Repair Kit ( *Indicates Contents)
44	530-015789	Retaining Ring			Carb. Gasket/Diaphragm Kit ( + Indicates Contents) --
45	530-014004	Crankcase/Crankshaft Ass'y.	107	530-035219	*+ Circuit Plate Gasket
46	530-010897	Fuel Pick-Up Ass'y.			*+ Mixture Needle Washer
47	530-069247	Fuel Line Kit	108	530-035211	"O" Ring Mixture
48	530-029602	Foam	109	530-035217	
49	530-010729	Fuel Cap w/Retainer	110	530-035218	
50	530-014267	Fuel Tank Ass'y.			
51	530-030073	Spark Plug (CJ-8Y)			
52	530-012244	Cylinder			
53	530-027525	Spacer			
54	530-029606	Leadwire Switch			
55	530-015776	Screw			
56	530-039137	Ignition Module		530-067870	Operator Manual
57	530-019178	Gasket		530-061344	Carton
58	530-026413	Piston Ring		530-029620	Instruction Decal
59	530-015162	Retainer		530-029624	Shroud Decal (Right)
60	530-014005	Piston Rod		530-029625	Shroud Decal (Left)
61	530-069274	Piston Kit (Incl. 58, 59 & Pin)			
62	530-015775	Screw			
63	530-014016	Crankcase Ass'y.			

---

# NOTES

# QUICK REFERENCE PAGE

**Read and follow all Warnings and Safety Instructions.  
Failure to do so can result in serious injury.**

## **A. WARNINGS AND SAFETY INSTRUCTIONS ..... PAGE NO. 3**

1. Wear eye protection.
2. Dress safely -- boots or safety shoes and long pants.
3. Check for worn, loose, missing, or damaged parts and repair.
4. Keep children, bystanders, and animals a minimum of 30 feet away.

## **B. FUELING YOUR ENGINE ..... PAGE NO. 7**

1. Eliminate all sources of sparks or flame where fuel is mixed, poured, or stored.
2. Use clean, fresh gasoline.
3. Use 3.2 oz. 2-cycle engine oil to 1 gal. gasoline OR 8 oz. 2-cycle engine oil to 2.5 gal. gasoline.
4. Mix fuel in an approved, marked container; mix and pour fuel in an outdoor area.
5. Move a minimum of 10 feet away from fuel and fueling site before starting engine.

## **C. STARTING INSTRUCTIONS ..... PAGE NO. 7**

1. Adjust the Throttle Knob properly.
2. Make sure the nozzle is directed away from people, animals, glass, and solid objects.
3. Pull the starter rope no more than 8 times to avoid flooding the engine.
4. To stop the engine, press and hold the "STOP" switch.

## **D. GENERAL MAINTENANCE ..... PAGE NO. 9**

1. Have all maintenance other than the recommended procedures described in the Operator's Manual performed by your Sears Service Center.
2. Disconnect the spark plug before performing maintenance except for carburetor adjustments.
3. Run fuel from the unit before storing.
4. Clean air filter frequently, but always after 5 hours of operation or 5 tanks of fuel, whichever is less.
5. Store in a dry place out of the reach of children.

# SEARS

## Operator's Manual

Model No.  
358.797910

### How to Order Repair Parts

**SEARS SERVICE  
IS AT YOUR SERVICE**

The Model Number will be found below the top handle with the Serial Number. Always mention the Model Number when requesting service or repair parts for your unit.

All parts listed herein may be ordered from any Sears Service Center and most Sears Stores.

WHEN ORDERING REPAIR PARTS ALWAYS GIVE THE FOLLOWING INFORMATION AS SHOWN IN THIS LIST:

- |  |   |
|--|---|
| 1. The PART NUMBER                       | 3. The PART DESCRIPTION                           |
| 2. The MODEL NUMBER<br><b>358.797910</b> | 4. The NAME OF ITEM --<br><b>GAS POWER BLOWER</b> |

If the parts you need are not stocked locally, your order will be transmitted to a Sears Repair Parts Distribution Center for handling.

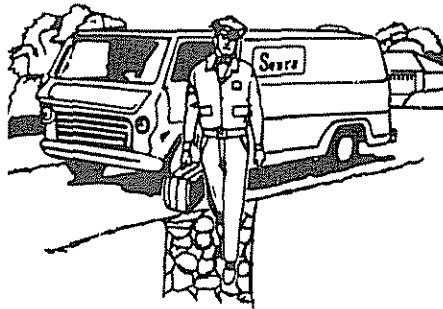

When you buy merchandise from Sears you get an extra value that nobody else can offer -- Sears Service.

Across town or across the country, Sears Service is always near, providing trustworthy, competent service technicians using only Sears specified factory parts.

Your Sears Merchandise takes on added value when you discover that Sears has Service Units throughout the country. Each is staffed by Sears-trained, professional technicians using Sears approved methods.

Sold by Sears, Roebuck and Co., Hoffman Estates, Ill. 60179 USA