

SEARS / CRAFTSMAN®

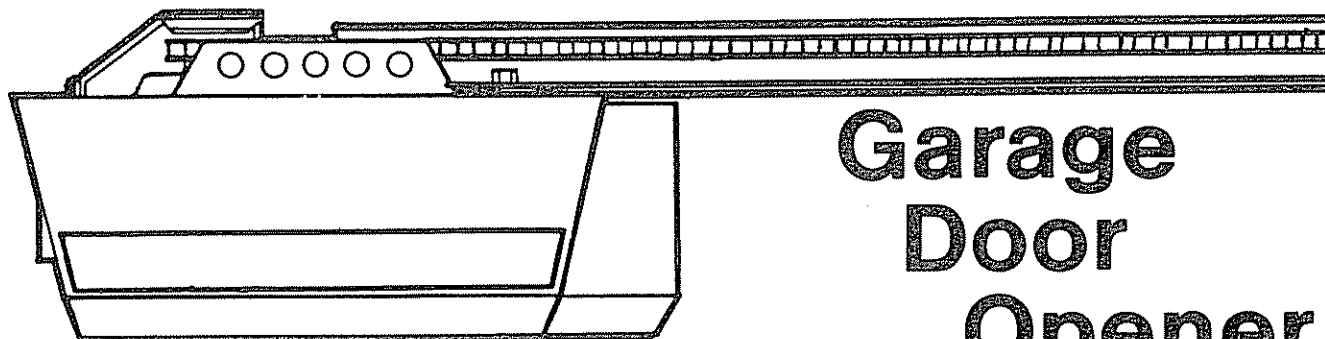

Garage Door Opener

MODELS:

139.53403 - 1/3 HP

139.53413 - 1/2 HP

139.53606 - 1/2 HP

139.53610 - 1/3 HP

Owners Manual

CAUTION

READ INSTRUCTIONS AND RULES
FOR SAFE OPERATION CAREFULLY

CONTENTS	PAGE
Features of Your Opener	2
Specifications	2
Accessories	2
Carton Check List	3
You'll Need Tools	3
Safety Rules	4
Operation of Your Opener	5
Maintenance Schedule	5
Assembly	6
Installation Information	9
Installation	9
Force & Limit Adjustment	17
Safety Reverse Test	18
Setting/Changing Code	19
Having a Problem?	20
Repair Parts, Rail Assembly	22
Repair Parts, Installation	22
Repair Parts, Chassis Assembly	23
How to Order Repair Parts	24
Maintenance Agreements	24
Sears Warranty	24

FASTEN OWNERS MANUAL NEAR GARAGE DOOR AFTER INSTALLATION IS COMPLETE.
PERIODIC CHECKS OF THE OPENER ARE REQUIRED TO INSURE SATISFACTORY OPERATION.

FEATURES OF YOUR OPENER

- Motor:** Permanently lubricated with automatic reset.
- Opener Light:** Turns on and off automatically. Provides 4-1/2 minute illumination for your safety and convenience.
- Safety System:** Independent up and down force adjustment. Door reverses automatically when obstructed in DOWN direction. Door STOPS when obstructed in UP direction.
- Easy Limit Adjustment:** Limits of door opening and closing adjusted by turning screws without removing chassis cover.
- Digital Radio Controls:** The code can be easily changed by the owner.
- 3-Channel Transmitter:** Three push buttons. Each button can activate one or more remote control devices. The large transmitter button is factory preset to operate the garage door opener.
- Emergency Disconnect:** Pull cord disconnect permits manual door operation.
- Automatic Reconnect:** The trolley halves re-connect for automatic operation when opener is energized after emergency disconnect.

SPECIFICATIONS

MOTOR

Type Permanent split capacitor
 Speed 1500 rpm
 Volts 120 Volts AC - 60 Hz. Only
 Current 4.5 amperes

DRIVE MECHANISM

Gears 16:1 worm gear reduction
 Drive Chain & cable with two-piece trolley on steel Tee rail
 Length of Travel Adjustable to 7-1/2 feet
 Travel rate 6 to 8 inches per second
 Lamp On when door starts in travel, off 4-1/2 minutes after stop.
 Door linkage Adjustable door arm Pull cord trolley release

SAFETY

Personal Push button & automatic reversal in down direction. Push button & automatic stop in up direction.
 Electronic Independent up & down force adjustment screws
 Electrical Motor overload protector and low voltage push button wiring
 Limit device Circuit actuated by limit nut
 Limit adjustment Screwdriver adjustment on side panel
 Start circuit Low voltage push button or radio control

DIMENSIONS

Length (overall) 124 in
 Headroom required 2 inches
 Hanging Weight 32 pounds

Sears offers many useful accessories for your garage door opener. They are illustrated below with Sears stock numbers and descriptions.

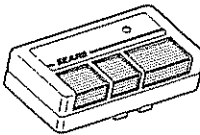
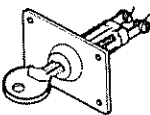
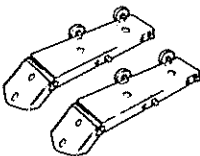
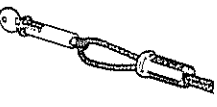
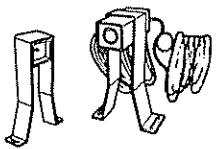
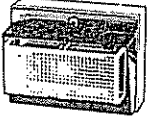
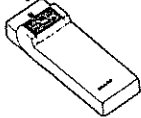
<p>53718</p> 	<p>EXTRA TRANSMITTER: Includes visor clip</p>	<p>53703</p> 	<p>OUTDOOR KEY SWITCH: Opens the garage door automatically from outside when transmitter is not handy</p>
<p>53709</p> 	<p>DOOR CLEARANCE BRACKETS: (FOR SECTIONAL DOORS ONLY) Replace top brackets and rollers on door to reduce height of door travel. For use when installing opener in garage with low headroom clearance.</p>	<p>53702</p> 	<p>EMERGENCY RELEASE KEY LOCK: REQUIRED for a garage with NO service door. Allows manual operation of garage door from outside in case of power failure.</p>
<p>53710</p> 	<p>INFRARED REVERSING SENSOR: An optional system which provides auxiliary support to the safety features built into your opener. If the sensor's invisible beam is broken, a closing door will reverse and an open door will not close</p>	<p>53717</p> 	<p>OPEN DOOR INDICATOR: Provides an illuminated signal when your garage door is open.</p>
<p>53716</p> 	<p>TOUCH CODE LOCK: Enables the homeowner to operate garage door opener from outside by entering code on specially designed keypad.</p>		

CARTON CHECK LIST

SEARS has packaged your Garage Door Opener in two cartons which contain all the parts and hardware illustrated below and on Page 22.

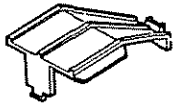

Sprocket Cover



Rail Grease

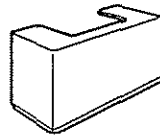

Light Lens (1)

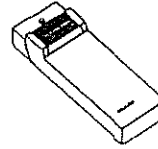

Touch Code Lock (1)
Model 139 53610 ONLY

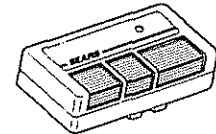

Transmitters (2)
Model 139 53413
(1 ONLY)

SEPARATE ALL HARDWARE FOR ASSEMBLY AND INSTALLATION PROCEDURES AS SHOWN BELOW.

ASSEMBLY HARDWARE

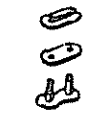

Master Link
(2)



Lockwasher
5/16" (3)



Washed Screw
5/16" - 18x1/2" (4)
*(2 mounted in Chassis)



Nut
5/16" - 18
(6)



Carriage Bolt
1/4" - 20x1/2" (4)



Lock Nut
1/4" - 20
(4)



Hex Screw
5/16" - 18 x 7/8" (2)

INSTALLATION HARDWARE



Clevis Pin
5/16" x 2-3/4" (1)

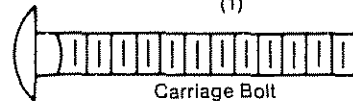

Carriage Bolt
5/16" - 18x2-1/2" (2)

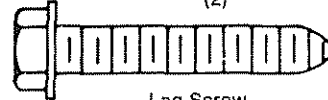

Lag Screw
5/16" - 18x1-7/8" (4)



Sheet Metal Screw
8ABx1" (2)



Clevis Pin
5/16" x 1" (2)



Hex Screw
5/16" - 18 x 7/8" (4)



Ring or Cotter Pin
Fastener (3)



Rope



Handle



Insulated
Staple (18)



Lock Washer
5/16" (6)



Nut
5/16" - 18
(6)

YOU'LL NEED TOOLS

During assembly and installation of your opener, the instructions will call for use of various hand tools. Have a stepladder handy, and those tools illustrated below: hammer, electric drill (& 3/16" and 5/16" drill bits), screwdriver, adjustable end wrench or socket wrench kit, wire cutters, tape measure, pliers and hack saw.

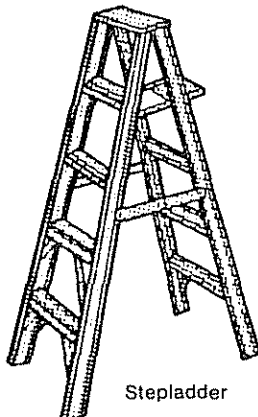

Stepladder

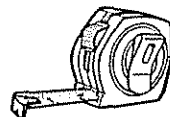

Tape Measure



Pliers



Hack Saw

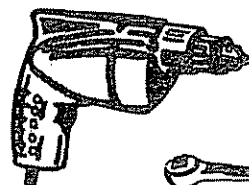

Electric Drill



Wire Cutters



Claw Hammer



Socket Wrench



Screwdriver

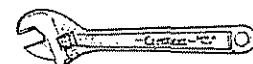

Adjustable End Wrench

Start By Reading These Important Safety Rules



THIS SAFETY ALERT SYMBOL MEANS CAUTION — PERSONAL SAFETY OR PROPERTY DAMAGE INSTRUCTION. READ THESE INSTRUCTIONS CAREFULLY.

THIS GARAGE DOOR OPENER IS DESIGNED AND TESTED TO OFFER REASONABLY SAFE SERVICE PROVIDED IT IS INSTALLED AND OPERATED IN STRICT ACCORDANCE WITH THE FOLLOWING SAFETY INSTRUCTIONS.

FAILURE TO COMPLY WITH THE FOLLOWING INSTRUCTIONS MAY RESULT IN SERIOUS PERSONAL INJURY OR PROPERTY DAMAGE.

CAUTION: IF YOUR GARAGE HAS NO SERVICE ENTRANCE DOOR, INSTALL MODEL 53702 EMERGENCY RELEASE KEYLOCK (PAGE 2). THIS ACCESSORY ALLOWS MANUAL OPERATION OF GARAGE DOOR FROM OUTSIDE IN CASE OF POWER FAILURE.



KEEP GARAGE DOOR BALANCED. Sticking or binding doors must be repaired. Garage doors, door springs, cables, pulleys, brackets and their hardware may be under extreme tension and can cause serious personal injury. **DO NOT ATTEMPT ADJUSTMENTS.** Call a garage door serviceman to move or adjust door springs or hardware.



DO NOT USE FORCE ADJUSTMENTS TO COMPENSATE FOR A BINDING OR STICKING GARAGE DOOR. Excessive force will interfere with the proper operation of the safety reverse system or damage the garage door. (Page 17).



DO NOT WEAR RINGS, WATCHES OR LOOSE CLOTHING while installing or servicing a garage door opener.



Fasten the **CAUTION LABEL** on the wall near the lighted wall control as a reminder of safe operating procedures.



To avoid serious personal injury from entanglement, **REMOVE ALL ROPES CONNECTED TO THE GARAGE DOOR** before installing the garage door opener.



Install wall control (or additional push buttons) **IN A LOCATION WHERE GARAGE DOOR IS VISIBLE, BUT OUT OF THE REACH OF CHILDREN. DO NOT ALLOW CHILDREN TO OPERATE THE WALL PUSH BUTTON(S) OR TRANSMITTER.** Serious personal injury from a closing garage door may result from misuse of opener.



DISENGAGE ALL EXISTING GARAGE DOOR LOCKS to avoid damage to garage door.



Installation and wiring must be in compliance with your local building and electrical codes. **CONNECT POWER CORD ONLY TO A PROPERLY GROUNDED OUTLET.**



CAUTION: Activate opener only when the door is in full view, free of obstruction and opener is properly adjusted. NO ONE SHOULD ENTER OR LEAVE THE GARAGE WHILE DOOR IS IN MOTION. DO NOT ALLOW CHILDREN TO PLAY NEAR DOOR.



LIGHTWEIGHT FIBERGLASS, ALUMINUM AND STEEL DOORS MUST BE SUBSTANTIALLY REINFORCED TO AVOID DOOR DAMAGE. (See page 15.) The best solution is to check with your garage door manufacturer for an opener installation reinforcement kit.



Use emergency release **ONLY** to disengage trolley and, if possible, **ONLY** when the door is closed. **DO NOT USE RED EMERGENCY RELEASE ROPE AND HANDLE TO PULL DOOR OPEN OR CLOSED**



THE SAFETY REVERSE SYSTEM TEST IS IMPORTANT. (See Pg. 18). Your garage door **MUST** reverse on contact with a one-inch obstacle placed on the floor. Failure to properly adjust the opener may result in serious personal injury from a closing garage door. **REPEAT TEST AT LEAST ONCE EVERY THREE MONTHS AND MAKE NEEDED ADJUSTMENTS.**



DISCONNECT ELECTRIC POWER TO GARAGE DOOR OPENER BEFORE MAKING REPAIRS OR REMOVING COVERS.

Operation of Your Opener

CAUTION

- **BEFORE YOU PROCEED, PLEASE READ THE SAFETY RULES ON PAGE 4 AND OPERATING INSTRUCTIONS ON THIS PAGE CAREFULLY.**
- **TO AVOID DIFFICULTY DURING INSTALLATION, DO NOT RUN OPENER UNTIL INSTRUCTED TO DO SO.**

USING THE OPENER

Your opener can be activated by any of the following devices (wait one-second between commands):

1. **The transmitter.** (The TOP (large) push button has been factory preset to operate door) Hold push button down until door starts to move
2. **The lighted wall control.** Hold button down until door starts to move.
3. **The Key Switch or Touch Code Lock** (if you have installed either of these accessories).

OPENING THE DOOR MANUALLY

The door can be operated manually by disconnecting it from the opener. **THE DOOR SHOULD BE FULLY CLOSED IF POSSIBLE. WEAK OR BROKEN SPRINGS COULD ALLOW AN OPEN DOOR TO FALL RAPIDLY. PROPERTY DAMAGE OR SERIOUS PERSONAL INJURY COULD RESULT.**

Simply pull down sharply on red emergency release handle and lift the door manually. To automatically reconnect the door to the opener, press the wall control push button

DO NOT USE THE EMERGENCY HANDLE TO PULL THE DOOR OPEN OR CLOSED.

- **DO NOT PERMIT CHILDREN TO PLAY IN DOOR AREA.**
- **OPERATE ONLY WHEN THE OPENER IS PROPERLY ADJUSTED AND DOOR IS VISIBLE AND UNOBSTRUCTED.**

WHEN OPENER IS ACTIVATED:

1. If open, door will close. If closed, door will open
2. If closing, the door will reverse.
3. If opening, the door will stop (allowing space for entry and exit of pets and for fresh air).
4. If the door has been stopped in a partially open position, it will close.
5. If an obstruction is encountered while closing, the door will reverse.
6. If an obstruction is encountered while opening, the door will stop.
7. If the optional Infrared Reversing Sensor is installed, the garage door will reverse in the closing cycle when the invisible beam is broken. An open door will not close when the beam is broken. The sensor has no effect in the opening cycle.

THE OPENER LIGHT will turn on under the following conditions: when the opener is initially plugged in; when power is interrupted; when the opener is activated. It will turn off automatically after 4-1/2 minutes. Bulb size-75 Watts maximum.

CARE OF THE OPENER

When properly installed, the opener will provide high performance with a minimum of maintenance. Opener does not require additional lubrication.

Most complaints of unsatisfactory opener operation can be traced to problems with the door itself...**OPENER IS NOT INTENDED TO CORRECT PROBLEMS THAT ARE CAUSED BY AN UNBALANCED OR BINDING DOOR, BROKEN DOOR SPRINGS OR BY FAULTY DOOR HARDWARE.**

When operated manually, a properly balanced door will stay in any point of travel while being supported entirely by its springs.

LIMIT AND FORCE ADJUSTMENTS: These adjustments must be checked and properly set when opener is installed. Only a screwdriver is required. **Weather conditions may cause minor changes in door operation requiring some re-adjustments, particularly during the first year of operation.** Page 17 refers to limit and force adjustments. Follow instructions carefully and repeat SAFETY REVERSE TEST after any adjustment.

THE SAFETY REVERSE SYSTEM IS IMPORTANT (SEE PG. 18). GARAGE DOOR MUST REVERSE ON CONTACT WITH A ONE-INCH OBSTACLE PLACED ON THE FLOOR. FAILURE TO PROPERLY ADJUST OPENER MAY RESULT IN SERIOUS PERSONAL INJURY FROM A CLOSING GARAGE DOOR.

CHAIN TENSION ADJUSTMENT: After installation of the opener and adjustment of forces and limits, chain may appear loose. This is normal.

TO CHECK THE CHAIN TENSION: disconnect the trolley by pulling the red emergency handle. If the chain returns to the position described and illustrated in Step 5. Page 9, DO NOT make ANY further adjustments.

THE TRANSMITTER: The 3-channel transmitter will operate more than one garage door opener, if desired. The additional push buttons may also be used to operate other remote control devices. Transmitter(s) may be secured to a car sun visor with clip(s) provided. Additional transmitters can be purchased at any time. (Refer to Accessories, Pg. 2).

Any new transmitters must be set to the same code as original transmitter and receiver. Page 19 explains how to change your existing code and how to use the transmitter(s) with other remote control devices. Self service of your radio controls is not recommended. If service is needed, contact your nearest Sears Service Center.

TRANSMITTER BATTERY: The 9-Volt battery should produce power for approximately one year. As long as there is adequate power, the transmitter battery test light will glow when a push button is pressed (and the opener will operate). When the light does not come on, replace battery. If transmission range lessens, check battery light.

Avoid the inconvenience of unexpected failure by replacing battery annually, preferably before winter. Use a general purpose, 9 volt battery.

TO CHANGE BATTERY: Remove visor clip and connecting screw in transmitter case. Set aside top of case and discard old battery. Snap connector onto new battery. Replace top of case and connecting screw. Replace visor clip.

MAINTENANCE OF YOUR OPENER

AT LEAST 4 TIMES A YEAR

MANUALLY OPERATE DOOR. If it is unbalanced or binding, call for professional garage door service.

CHECK TO MAKE SURE DOOR OPENS AND CLOSES FULLY. Adjust Limits and/or Force if necessary

REPEAT SAFETY REVERSE TEST. Make any necessary adjustments (see page 18).

TWICE A YEAR

CHECK CHAIN TENSION. Adjust if necessary.

ONCE A YEAR

OIL DOOR ROLLERS, BEARINGS AND HINGES.

REPLACE THE TRANSMITTER BATTERY, preferably before winter.

Assembly

TO AVOID INSTALLATION DIFFICULTIES, DO NOT RUN THE GARAGE DOOR OPENER UNTIL YOU ARE INSTRUCTED TO DO SO.

STEP 1 Assemble Tee Rail & Attach Cable Pulley Bracket

CAUTION: Do not tighten the lock nuts until bolt necks are seated in square holes.

The center rail section **MUST** be positioned on the **LEFT SIDE** of end rails as shown. Otherwise, trolley will hit against nut when installed (Pg. 7).

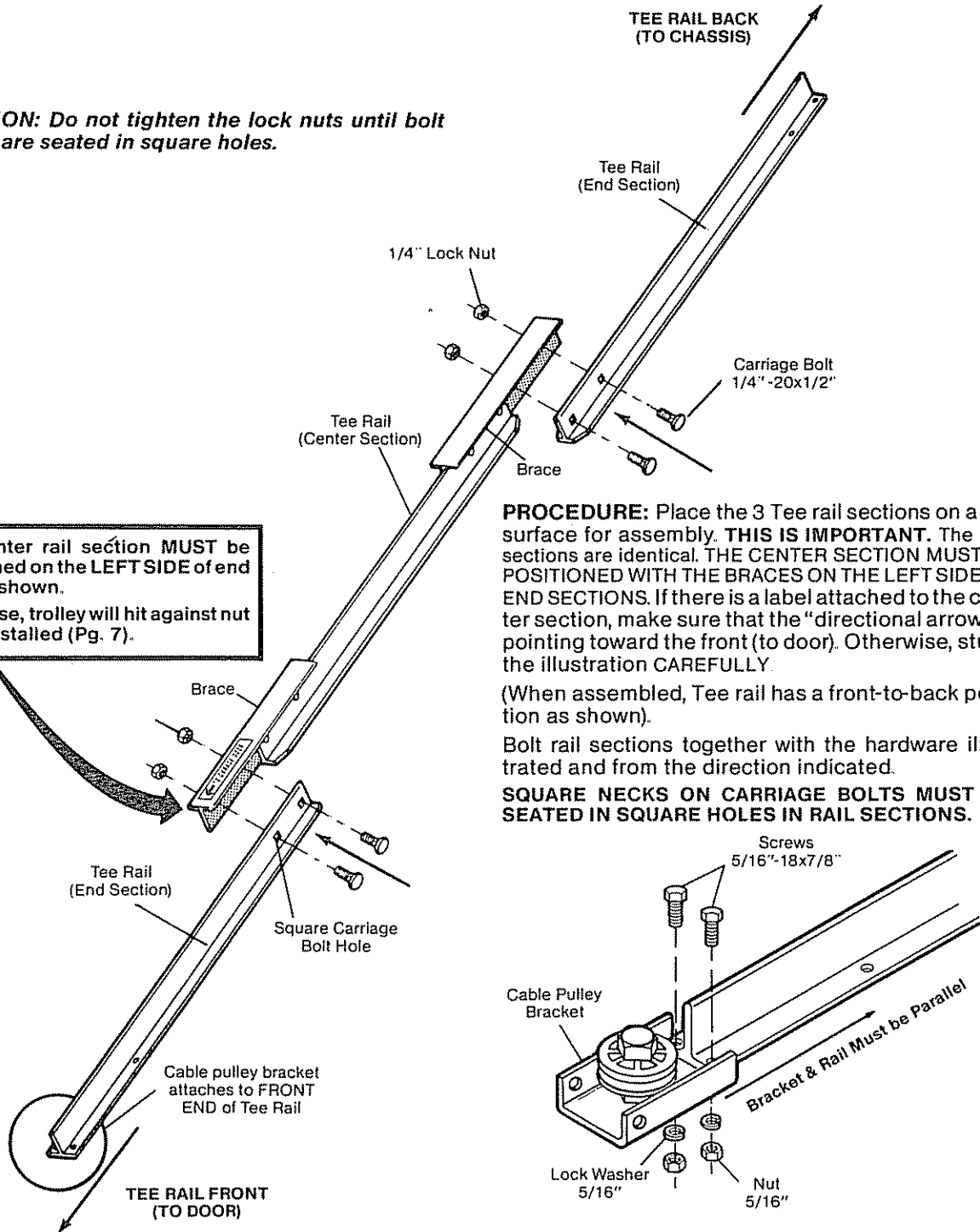

PROCEDURE: Place the 3 Tee rail sections on a flat surface for assembly. **THIS IS IMPORTANT.** The end sections are identical. THE CENTER SECTION MUST BE POSITIONED WITH THE BRACES ON THE LEFT SIDE OF END SECTIONS. If there is a label attached to the center section, make sure that the "directional arrow" is pointing toward the front (to door). Otherwise, study the illustration CAREFULLY.

(When assembled, Tee rail has a front-to-back position as shown).

Bolt rail sections together with the hardware illustrated and from the direction indicated.

SQUARE NECKS ON CARRIAGE BOLTS MUST BE SEATED IN SQUARE HOLES IN RAIL SECTIONS.

Position cable pulley bracket on front end of tee rail as shown. Fasten securely with the hardware provided. **IMPORTANT:** When tightening screws, be sure to keep bracket parallel to rail. Otherwise, rail may bow when opener is operated.

Assembly

STEP 2 Install Trolley & Attach Chain Retainer Bracket

As a temporary stop, insert a screwdriver into hole in front end of Tee rail as shown. Slide the inner trolley onto the Tee rail until it is firmly against the screwdriver.

NOTE: If trolley hits against nut on Tee rail, center section was attached from wrong side and must be repositioned. Review Step 1.

Slide the outer trolley onto the Tee rail until it partially engages the inner trolley and stops.

TO FULLY ENGAGE TROLLEY: With a hammer, firmly tap the back end of outer trolley just below the rail guide. Outer trolley must move forward to fully engage inner trolley. Be careful to avoid damaging trolley spring.

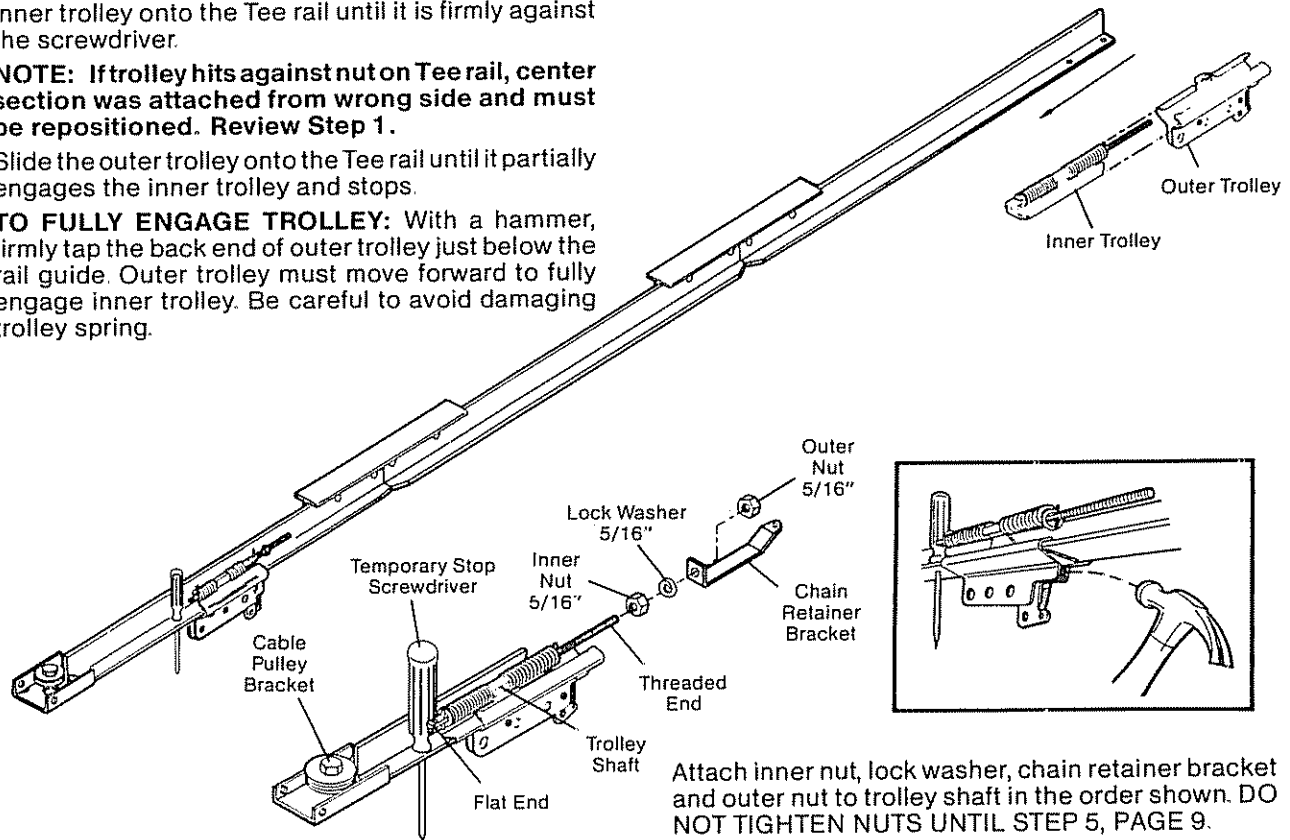

Attach inner nut, lock washer, chain retainer bracket and outer nut to trolley shaft in the order shown. **DO NOT TIGHTEN NUTS UNTIL STEP 5, PAGE 9.**

STEP 3 Attach Tee Rail to Opener Chassis



USE ONLY THOSE SCREWS MOUNTED IN TOP OF OPENER CHASSIS. FAILURE TO DO SO WILL CAUSE SERIOUS DAMAGE TO THE DOOR OPENER.

PROCEDURE: Place opener chassis on packing material to protect cover. For convenience, place a support under the cable pulley bracket.

Remove 5/16"-18x1/2" washered screws mounted in top of opener chassis. Align holes in back end of Tee rail with holes in opener chassis. **Fasten the rail to the chassis with washered screws previously removed. CAUTION: USE ONLY THESE SCREWS!** Use of any other screws will cause serious damage to door opener. Tighten screws securely.

Insert a 5/16"-18x1/2" washered screw into trolley stop hole in the Tee rail as shown. Tighten securely with a 5/16" nut.

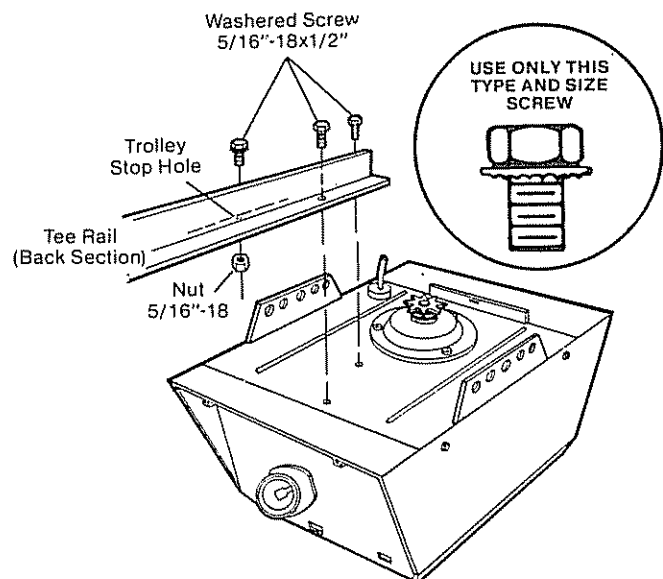

Assembly

STEP 4 Install Chain and Cable

DO NOT REMOVE CHAIN AND CABLE FROM CARTON.

Detach cable from side of carton and fasten to trolley with a master link from coin envelope.

MASTER LINK PROCEDURE: Push pins of master link bar through loop of cable and hole in flat end of trolley shaft. (A) Push cap over pins and onto notches. Slide clip-on spring over cap and onto pin notches until both pins are locked in place.

Caution: Keep chain taut while installing to help prevent kinking.

With trolley against the screwdriver, dispense cable around pulley. Proceed back around opener sprocket (B) - be sure sprocket teeth engage chain - and forward to chain retainer bracket (C).

Use second master link to connect chain to retainer bracket. Check to make sure chain is not twisted.

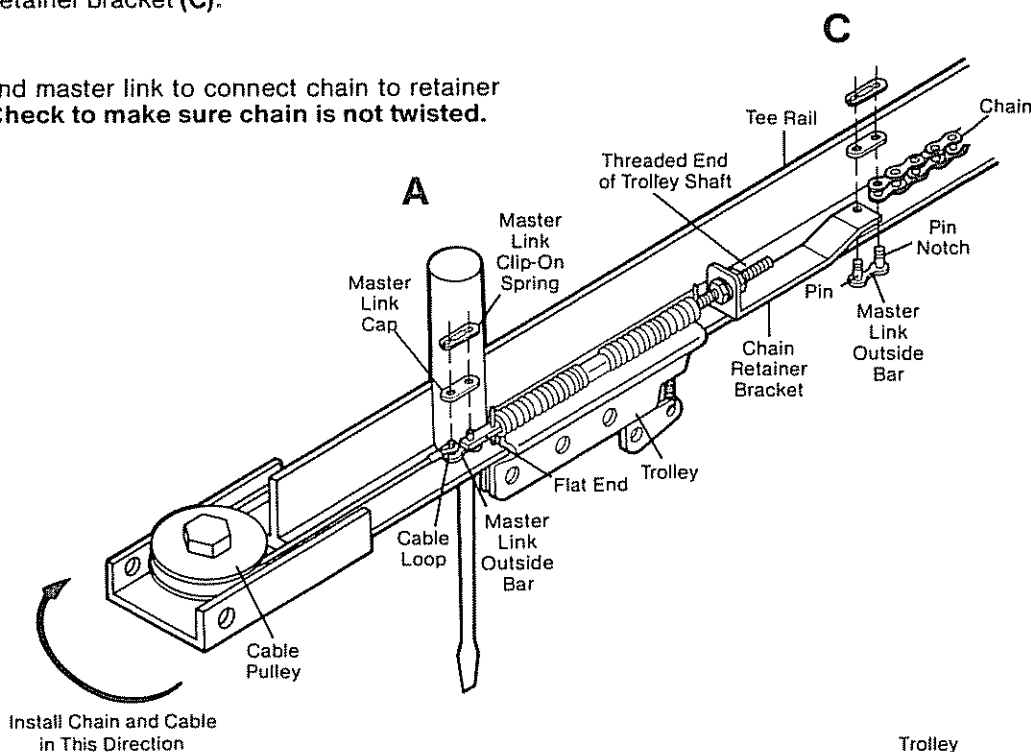
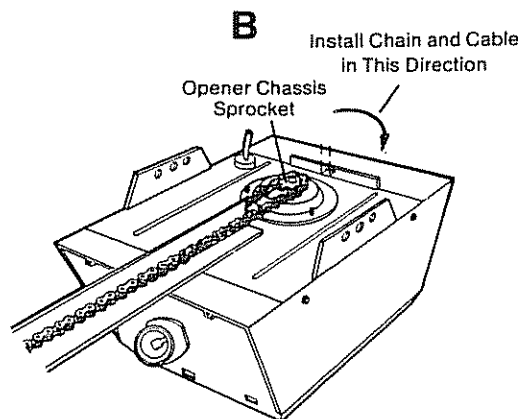

As a permanent trolley stop, insert 5/16" washed screw and nut into remaining hole in Tee rail front. Tighten securely. **REMOVE SCREWDRIVER.**

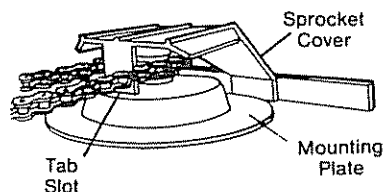
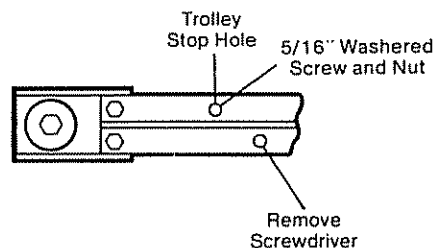

Attach sprocket cover to chassis as shown. Insert back tab in chassis slot. Then bend cover forward and insert front tab in slot provided on mounting plate.

Assembly

STEP 5

Tighten the Chain and Cable

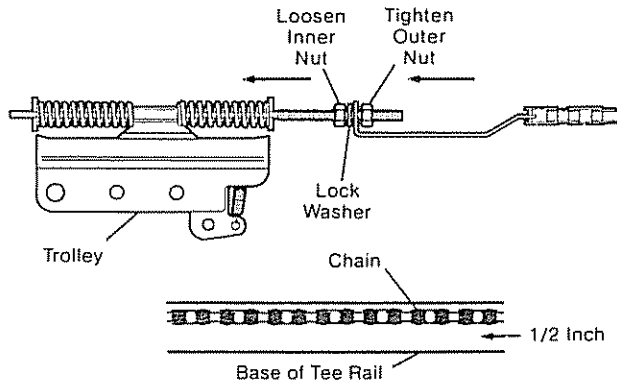

CAUTION: Keep the chain from twisting as nuts are turned.

PROCEDURE: Thread the outer nut toward trolley as shown (Loosen inner nut first, if necessary).

Tension is correct when the chain is approximately 1/2" above base of Tee rail midway between cable pulley bracket and chassis.

To maintain proper tension, turn inner nut toward chain retainer bracket until tight.

Sprocket noise can result if chain is either too loose or too tight.

CAUTION: Do not overtighten chain and cable. Refer to Page 5.

ASSEMBLY OF YOUR GARAGE DOOR OPENER IS NOW COMPLETE.

BEFORE YOU PROCEED WITH THE INSTALLATION OF YOUR GARAGE DOOR OPENER BE SURE TO COMPLY WITH THE FOLLOWING SAFETY RULES:



KEEP GARAGE DOOR BALANCED. STICKING OR BINDING DOORS MUST BE REPAIRED. THE GARAGE DOOR, THE DOOR SPRINGS, CABLES, PULLEYS, BRACKETS AND THEIR HARDWARE MAY BE UNDER EXTREME TENSION AND CAN CAUSE SERIOUS PERSONAL INJURY. DO NOT ATTEMPT ADJUSTMENTS. CALL A GARAGE DOOR SERVICEMAN TO MOVE, LOOSEN OR ADJUST DOOR SPRINGS OR HARDWARE.



DO NOT WEAR WATCHES, RINGS OR LOOSE CLOTHING WHILE INSTALLING OR SERVICING A DOOR OPENER.

AS YOU PROCEED WITH THE REMAINING INSTRUCTIONS IN THIS OWNERS MANUAL, YOU MAY FIND IT HELPFUL TO REFER TO THE FOLLOWING ILLUSTRATION OF THE FULLY ASSEMBLED AND INSTALLED GARAGE DOOR OPENER.

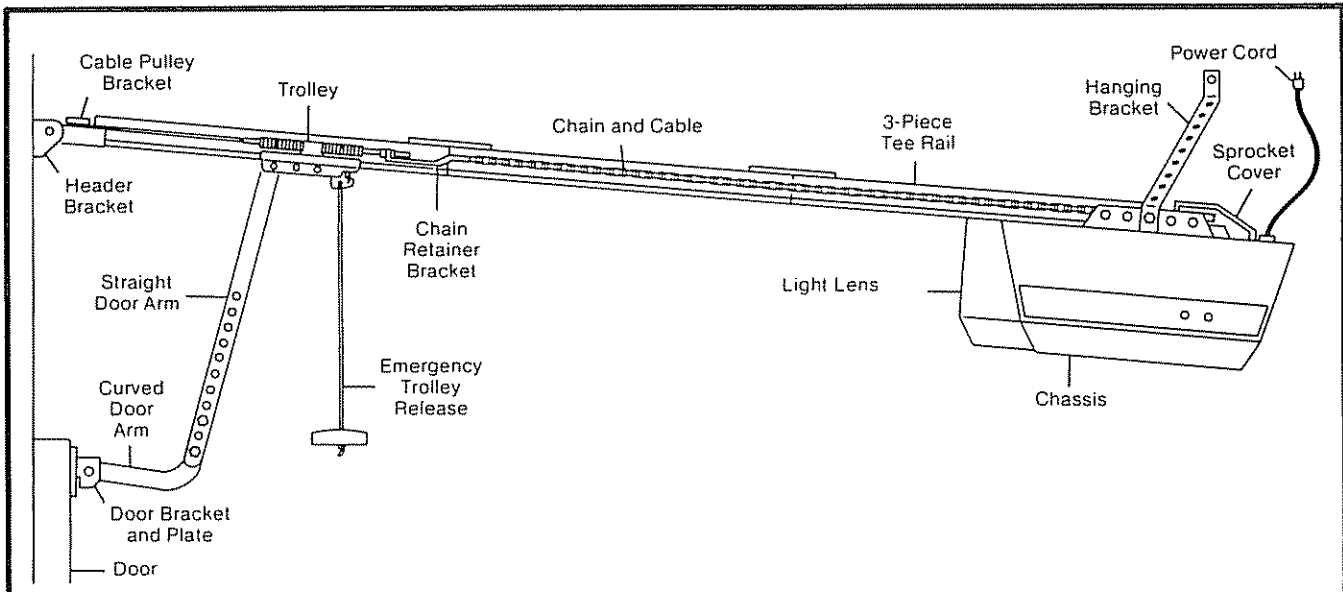

IT IS RECOMMENDED THAT THE OPENER BE INSTALLED 7 FEET OR MORE ABOVE THE FLOOR WHERE SPACE PERMITS.

CERTAIN INSTALLATION PROCEDURES VARY ACCORDING TO GARAGE DOOR TYPES. WHERE THE DIFFERENCES OCCUR, BE SURE TO FOLLOW ONLY THOSE INSTRUCTIONS WHICH APPLY TO YOUR DOOR CONSTRUCTION.

Installation

STEP 1 Position & Install Header Bracket

Installation procedures vary according to garage door types. Follow only those instructions which apply to your door as illustrated below.



THE HEADER BRACKET MUST BE RIGIDLY FASTENED TO THE HEADER WALL OR CEILING. REINFORCE WALL OR CEILING WITH 2x4 IF NECESSARY.

1. With door closed, locate and mark the vertical centerline of garage door. Extend line onto header wall above door.
2. Locate height for header bracket by opening door to highest point of travel as shown. Draw an intersecting horizontal line on header wall 2" above high point. This height provides travel clearance for top edge of door.

NOTE: When headroom is not sufficient for 2" clearance, the bottom edge of bracket may be placed parallel to the high point of travel, or bracket may be attached to ceiling.

Door Clearance Brackets are designed for low headroom installations (Page 2). They replace top brackets and rollers on the garage door, thereby lowering the high point of door travel. Installation instructions are contained in the accessory carton.

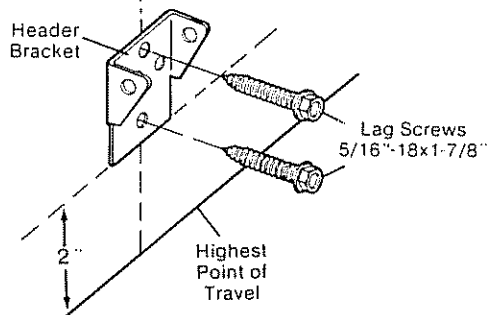

INSTALLATION SECTIONAL DOOR AND 1-PIECE DOOR WITH TRACK

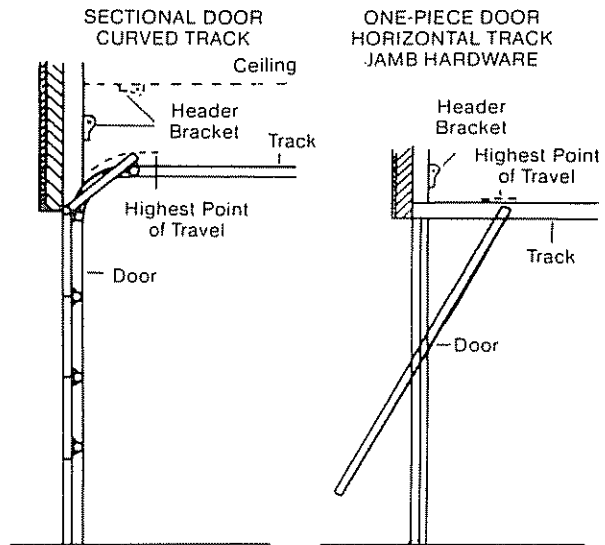

3. Position bracket as shown (bottom edge of the bracket on horizontal line). Mark either top and bottom or left and right bracket holes. Drill 3/16" pilot holes and fasten bracket.

INSTALLATION 1-PIECE DOOR WITHOUT TRACK

ONE-PIECE DOOR
NO TRACK
PIVOT HARDWARE

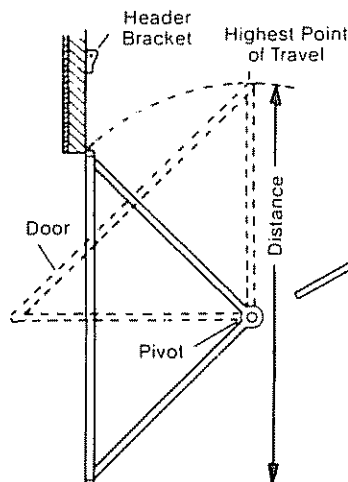

ONE-PIECE DOOR
NO TRACK
JAMB HARDWARE

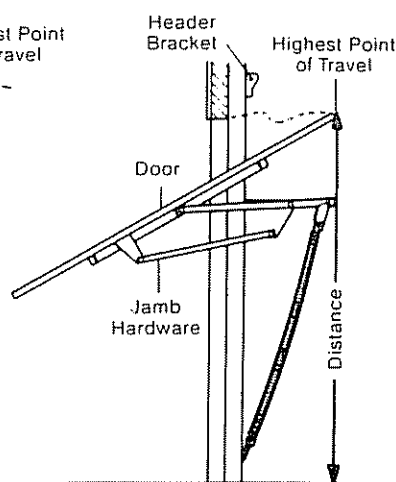

1. Follow instructions as described in 1 above
2. Locate height for header bracket by opening door to highest point of travel as shown. Measure the distance from top of door to floor. Subtract actual height of door. Add 8" to the remainder. Refer to example below

NOTE: If the total number of inches exceeds the height available in your garage, use the maximum height possible. On finished ceilings, do not position the bracket closer than 1/2" from ceiling.

3. Measuring from top of door, draw an intersecting horizontal line on header wall at determined height. Position bottom edge of header bracket on the horizontal line, centering bracket on vertical line. Mark either top and bottom or left and right holes. Drill 3/16" pilot holes and fasten the bracket with 5/16" x 1-7/8" lag screws as shown above.

EXAMPLE

Distance from top of door (at highest point of travel) to floor	92"
Actual height of door	-88"
Remainder	4"
Add	+ 8"
Bracket height on header wall (Measure UP from top of door in closed position.)	=12"

Installation

STEP 2 Attach Tee Rail to Header Bracket

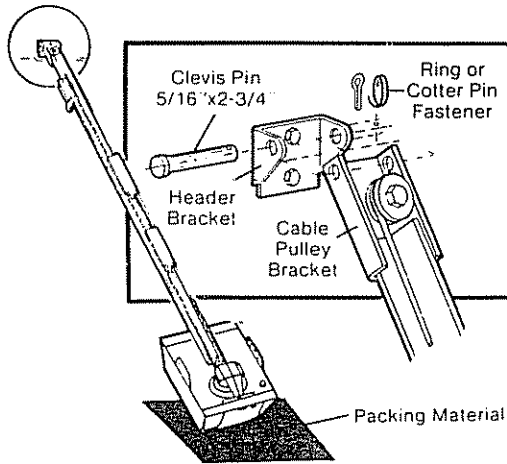

PROCEDURE: Position opener chassis on garage floor below header bracket. Use packing material base to protect cover. **NOTE:** To enable Tee rail to clear sectional door springs, it may be necessary to lift the chassis onto a temporary support.

CAUTION: Chassis must either be secured to the support or held firmly in place by another person.

Raise Tee rail until cable pulley and header brackets come together. Align bracket holes and join with clevis pin as shown. Secure with a ring or cotter pin fastener (if cotter pin is used, spread to secure).

STEP 3 Position Opener Chassis

Follow instructions which apply to your door type as illustrated below



TO PREVENT DAMAGE TO ALL LIGHTWEIGHT DOORS AND DOORS WITH WINDOWS, DO NOT REST THE OPENER ON THE DOOR.

SECTIONAL and ONE-PIECE DOOR WITH TRACK INSTALLATION

NOTE: A 2x4 is convenient for setting an ideal door-to-Tee rail distance. It is not necessary where headroom is insufficient.

PROCEDURE: Raise the opener chassis onto a stepladder. Open garage door. Place a 2x4 on edge on top section of door near centerline. Rest Tee rail on 2x4

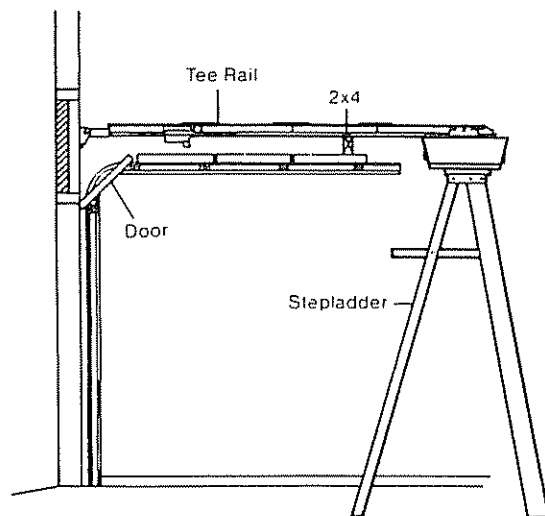

ONE-PIECE DOOR WITH NO - TRACK INSTALLATION

PROCEDURE: Measure the distance from floor to top of door (in fully open position and parallel to the floor)

Using a stepladder as a support, raise the opener chassis to the same distance from the floor (chassis will have a slight angle as shown)

The top of the door should be level with the top of the opener. For maximum efficiency, do not position the opener chassis more than 2 inches above this point.

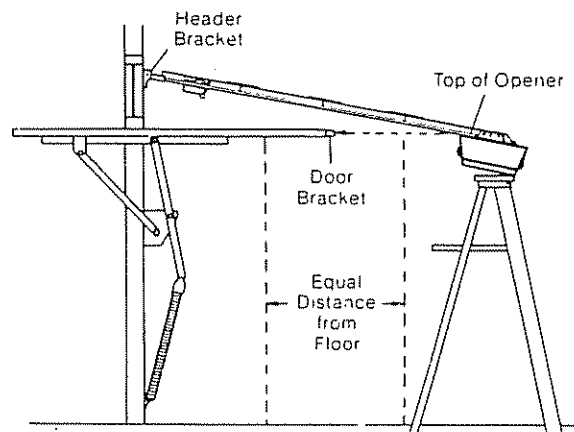

Installation

STEP 4 Hang Opener Chassis

THE OPENER CHASSIS MUST BE SECURELY FASTENED TO A STRUCTURAL SUPPORT OF GARAGE. Three representative installations are shown. Yours may be different. Hanging brackets should be angled (Fig. 1) or crossed (Fig. 2) to provide rigid support. On finished ceilings (Fig. 3), attach a sturdy metal bracket (not supplied) to ceiling joists before installing opener.

PROCEDURE: On EACH side of opener measure the distance from chassis to structural support.

Cut both pieces of the hanging bracket to required lengths. Flatten one end of each bracket and bend or twist to fit fastening angles. **Do not bend at bracket holes.** Drill 3/16" pilot holes in structural support. Attach flattened ends of brackets to the support with 5/16"x1-7/8" lag screws.

Lift opener and fasten to hanging bracket as shown. **Check to make sure Tee rail is centered over door.** REMOVE 2x4. Operate door manually. If door hits the rail, raise header bracket.

Grease top and underside of rail surface on which trolley slides. A tube of grease is supplied.

FIGURE 2

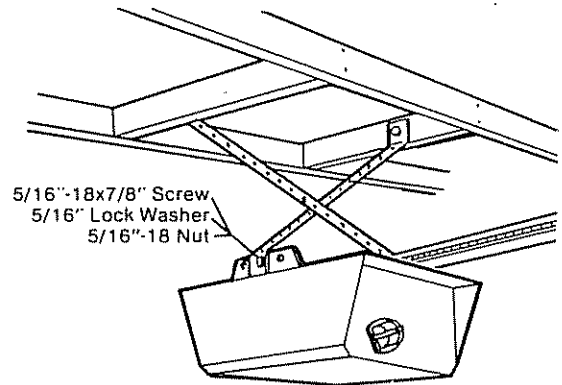

FIGURE 1

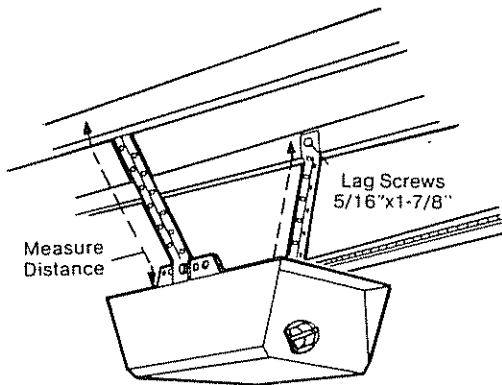
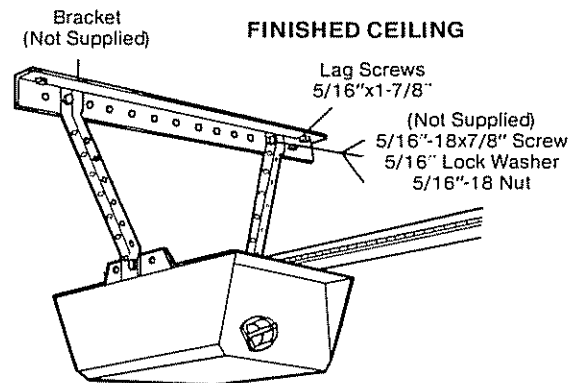

FIGURE 3



STEP 5 Attach Emergency Release Rope & Handle



USE EMERGENCY RELEASE ONLY TO DISENGAGE TROLLEY. DO NOT USE ROPE AND HANDLE TO PULL DOOR OPEN OR CLOSED.

PROCEDURE: Thread one end of rope through hole in top of red handle so 'NOTICE' reads right side up as shown. Secure with an overhand knot. **NOTE: Knot should be at least 1 inch from end of rope to prevent slipping.** Thread other end of rope through hole in release arm of outer trolley. Adjust rope length so that handle is 6 feet above the floor. Secure with an overhand knot as above.

NOTE: If it is necessary to cut rope, heat seal cut end with a match or lighter to prevent fraying and/or raveling.

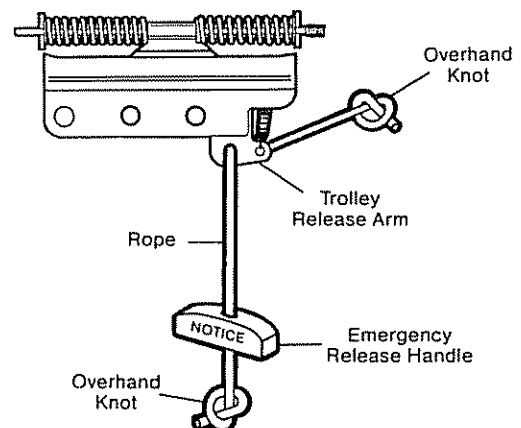

Installation

STEP 6 *Install Wall Control*



LOCATE WALL PUSH BUTTON (OR ANY ADDITIONAL PUSH BUTTONS) WHERE GARAGE DOOR IS VISIBLE, AWAY FROM DOOR AND DOOR HARDWARE AND OUT OF THE REACH OF CHILDREN.

SERIOUS PERSONAL INJURY FROM A MOVING GARAGE DOOR MAY RESULT FROM MIS-USE OF THE OPENER. DO NOT ALLOW CHILDREN TO OPERATE WALL PUSH BUTTON(S) OR THE TRANSMITTER.

FASTEN THE CAUTION LABEL ON THE WALL NEAR WALL PUSH BUTTON AS A REMINDER OF SAFE OPERATING PROCEDURES.

PROCEDURE: Remove about a 1/4" of insulation from each end of the 2-strand bell wire. Connect one end to the screw terminals on the back of wall control as shown.

Fasten the wall control to an inside garage wall with the 8ABx1" sheet metal screws provided. A convenient place is beside the service door and OUT OF THE REACH OF CHILDREN.

Run the bell wire up the wall and across the ceiling to garage door opener. Use insulated staples to secure wire.

The receiver terminals and the antenna are located on the back panel of the opener chassis. Position antenna wire as shown. Then connect wire by color to the white and red opener terminal screws.

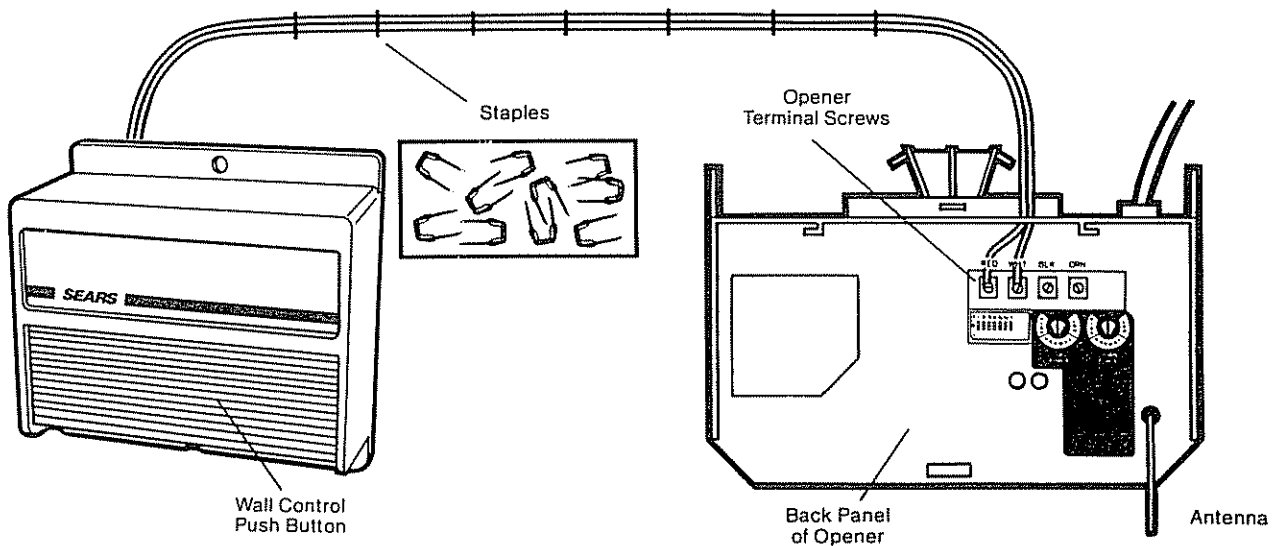
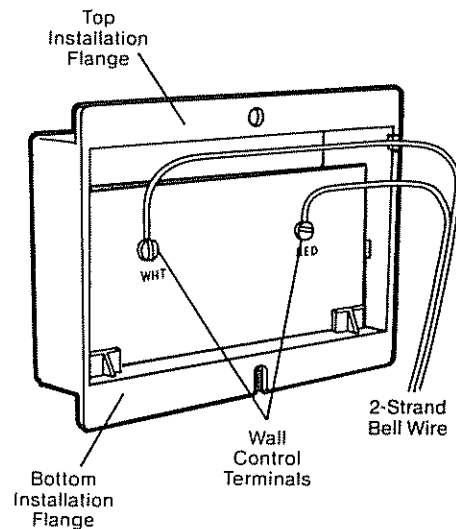

OPERATION OF THE LIGHTED WALL CONTROL

Press and release to open or close door.

Press and release again to REVERSE door during CLOSING cycle or to STOP door during OPENING cycle

NOTE: Wait about 1-second between commands.

WIRING INSTRUCTIONS FOR ACCESSORIES

Open Door Indicator:

To white & orange opener terminals

Outdoor Key Switch:

To red & white opener terminals

Touch Code Lock:

To red and white opener terminals

Infrared Reversing System:

To white & black opener terminals

Installation

STEP 7 Install Light and Lens

PROCEDURE: Install a light bulb, (75 Watts Maximum) in socket as shown. The light will turn on and remain lit for 4-1/2 minutes when power is connected. After 4-1/2 minutes it will turn off.

If light bulb burns out prematurely due to vibration, replace with a "rough service" bulb.

INSTALLING LENS:

Slide lens into the lens guides as shown. Snap bottom tabs into lens slots.

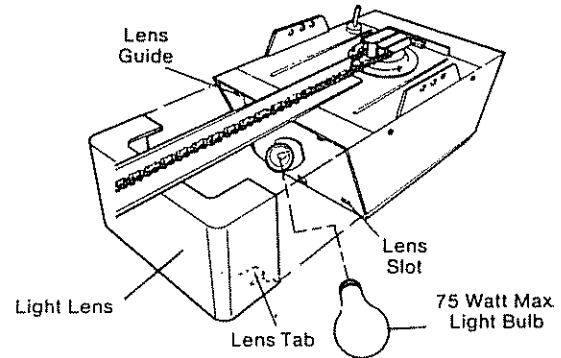

STEP 8 Connect Electric Power



TO AVOID SERIOUS PERSONAL INJURY FROM ENTANGLEMENT, REMOVE ALL ROPES CONNECTED TO THE GARAGE DOOR BEFORE OPERATING OPENER.

TO AVOID DAMAGE TO GARAGE DOOR AND OPENER, MAKE DOOR LOCKS INOPERATIVE BEFORE CONNECTING ELECTRIC POWER. USE A WOOD SCREW OR NAIL TO HOLD THE LOCKS IN "OPEN" (UNLOCKED) POSITION.

INSTALLATION AND WIRING MUST BE IN COMPLIANCE WITH LOCAL ELECTRICAL AND BUILDING CODES.

OPERATION AT OTHER THAN 120V 60Hz WILL CAUSE OPENER MALFUNCTION AND DAMAGE.

Opener **MUST** be permanently wired or plugged into a grounded 3-prong receptacle wired according to local electrical codes. **DO NOT** use a 2-wire adapter. **DO NOT** use an extension cord.

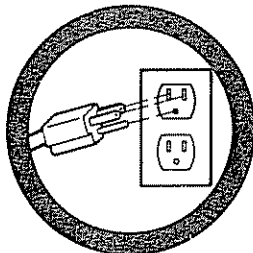

RIGHT

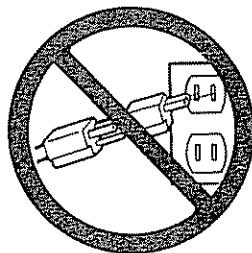

WRONG

IF LOCAL CODES REQUIRE PERMANENT WIRING:



DISCONNECT POWER AT FUSE BOX BEFORE PROCEEDING.

PROCEDURE: Refer to illustration. Make connection through the 7/8 inch diameter hole in top of opener chassis

1. Remove opener chassis cover by removing the cover screws
2. Remove attached 3-prong cord
3. Connect the black (line) wire to the black wire on terminal block; white (neutral) wire to the white terminal wire; the green (ground) wire to green ground screw.

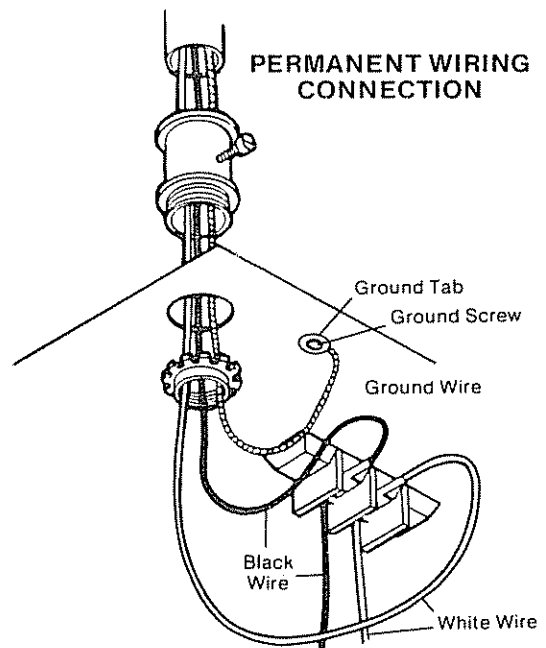

CAUTION: BE SURE THAT UNIT IS GROUNDED ACCORDING TO LOCAL CODE.

IMPORTANT NOTE: TO AVOID INSTALLATION DIFFICULTIES, DO NOT RUN OPENER NOW.

Installation

STEP 9 *Install Door Bracket and Plate*

Follow instructions which apply to your door type as illustrated below



TO PREVENT DAMAGE TO LIGHTWEIGHT GARAGE DOORS, ALWAYS REINFORCE THE INSIDE OF DOOR—BOTH VERTICALLY AND HORIZONTALLY—WITH 2x4 BOARDS OR ANGLE IRON.

Horizontal brace should be at least 6 feet long. Vertical brace should cover height of top panel. **The best solution is to check with your garage door manufacturer for a door reinforcement kit for an opener installation.**

Sectional Door Installation Procedure

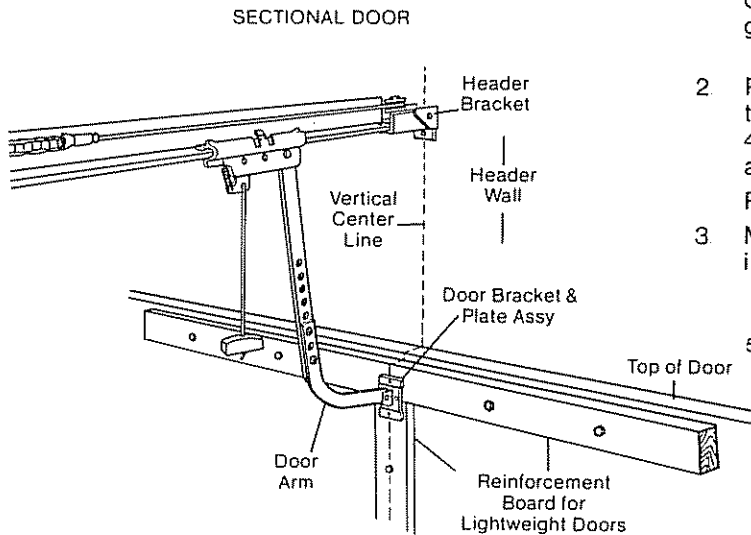

1. Assemble the door bracket and plate as shown. Center bracket on previously marked vertical guideline.
2. Position bracket assembly on face of door within the following limits: **A.** Top edge of bracket 2" to 4" below the top edge of door. **B.** Directly below any structural support across top of door. Placement depends on your particular needs.
3. Mark and drill 5/16" TOP and BOTTOM fastening holes. Secure bracket as shown.

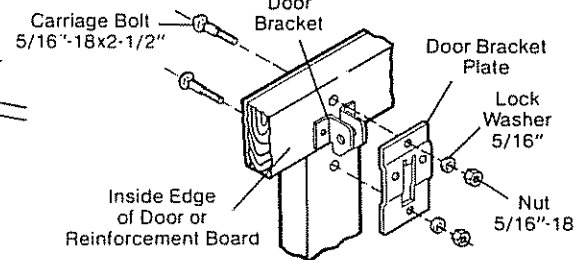

All One-Piece Door Installation Procedure

NOTE: The door bracket has left and right side fastening holes. Assemble and install the door bracket and plate if your installation requires top and bottom fastening holes.

1. Center bracket (with or without plate as required) on top edge of door as shown. Mark holes.
2. Drill two 5/16" holes and fasten door bracket with hardware supplied

NOTE: If the door has no exposed framing, drill 3/16" pilot holes and use 5/16"x1-1/2" lag screws (not supplied) to fasten bracket to top of door.

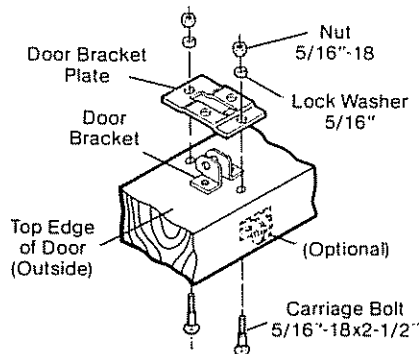

NOTE: Door bracket may be installed on face of door if required for your installation. (Refer to dotted line drawing.) **HOWEVER,** drill 3/16" pilot holes and substitute 5/16"x1-1/2" lag screws (not supplied) to fasten the bracket to door.

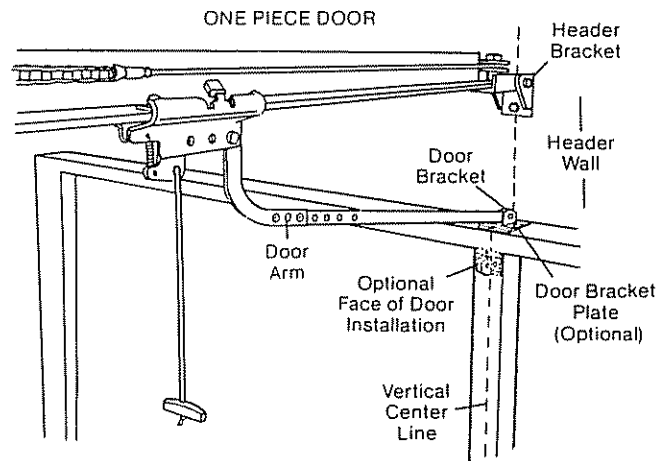

Installation

STEP 10 *Connect Door Arm to Trolley*

Follow only those instructions which apply to your door type

SECTIONAL DOOR INSTALLATION ONLY

FIG. A. Make sure garage door is closed tight. Connect straight door arm section to trolley with a clevis pin. Secure with a ring or cotter pin fastener (if cotter pin is used, spread to secure.)

Fasten curved section to door bracket in the same way.

FIG. B. Bring arm sections together. Find two pairs of holes that line up and join sections

Insert screws from straight arm side. Select holes as far apart as possible to increase door arm rigidity

FIG. C. If holes do not line up as shown in FIG. B, cross door arms in scissor fashion. When one set of holes lines up, insert screw and 'finger tighten' with a lock washer and nut

Pull the emergency release rope to disengage trolley.

Bring arm sections together and insert screw into second set of holes. Install lock washer and nut. Tighten screws

Proceed to Step 1, Pg. 17. The trolley will re-engage automatically when opener is operated.

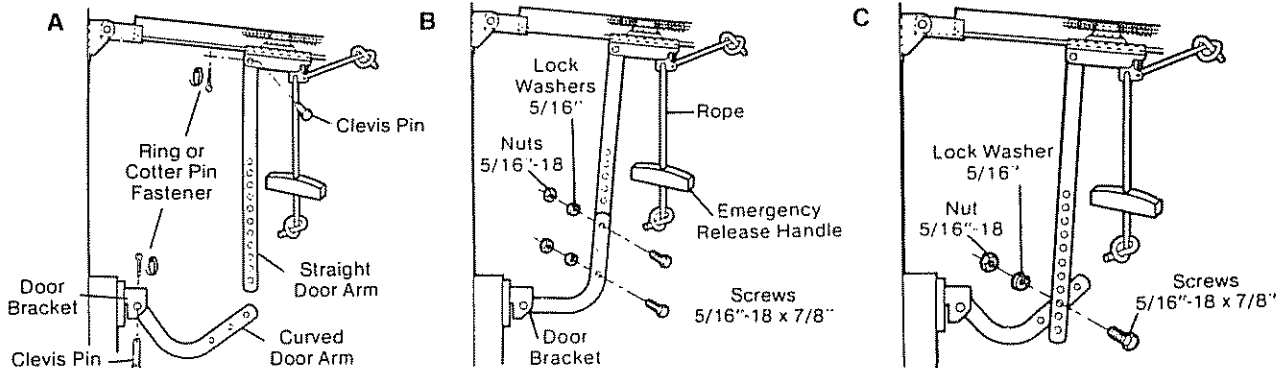

ALL ONE-PIECE DOOR INSTALLATIONS

ASSEMBLE DOOR ARM PROCEDURE: Connect straight and curved door arm sections together to longest possible length. With door closed, connect straight door arm section to door bracket with a clevis pin. Secure with a ring or cotter pin fastener (if cotter pin is used, spread to secure)

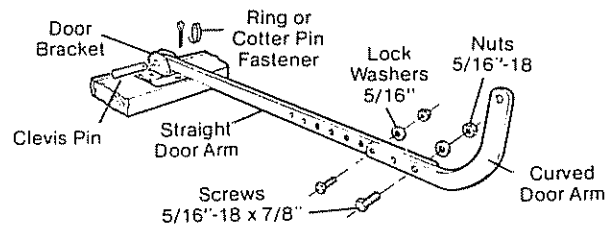

Before connecting door arm to trolley, limits of travel must be adjusted on one-piece doors. Limit adjustment screws are located on left side panel of opener as shown in illustration on Pg. 17. Follow procedures below.

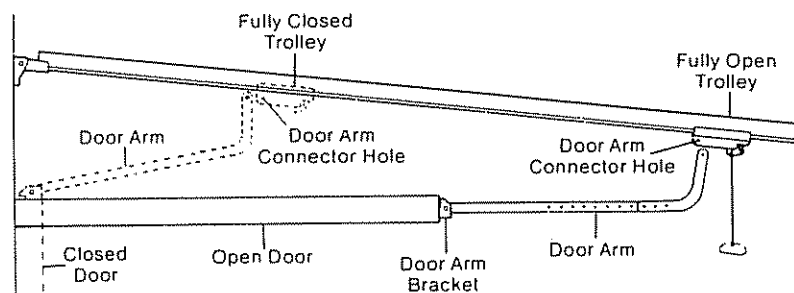

ADJUSTMENT PROCEDURES

PROCEDURE - OPEN DOOR ADJUSTMENT

Decrease up limit. Turn UP limit adjustment screw counter-clockwise 4 complete turns.

Press Wall Control button. Trolley will travel to full open. Manually raise door to open position (parallel to floor) and lift door arm to trolley. The arm should touch trolley just in back of door arm connector hole as shown in solid line drawing. If arm does not extend far enough, adjust limit further. One full turn equals 2 inches of door travel.

CONNECT DOOR ARM TO TROLLEY: With door closed, join curved arm to connector hole in trolley with remaining clevis pin. Secure with ring or cotter pin fastener. **NOTE: It may be necessary to lift door slightly to make connection.**

Run opener through a complete travel cycle. If top of door has a slight downward slant in full open position, decrease UP limits until door is parallel to floor.

PROCEDURE - CLOSED DOOR ADJUSTMENT

Decrease down limit. Turn DOWN limit adjustment screw clockwise 8 complete turns.

Press Wall Control button. Trolley will travel to full close. Manually close door and lift door arm to trolley. Arm should touch trolley just ahead of door arm connector hole as shown in dotted line drawing. If arm is behind the connector hole, adjust limit further. One full turn equals 2 inches of door travel.

Adjustment

STEP 1 Adjust UP and DOWN Limits

LIMIT ADJUSTMENT settings regulate the points at which the door will stop when moving up or down

NOTE: Door **STOPS** in UP direction if anything interferes with door travel. The door **REVERSES** in DOWN direction if anything interferes with door travel (including binding or unbalanced doors).

PROCEDURE: To operate opener, press Wall Control push button or transmitter. Run opener through a **COMPLETE TRAVEL CYCLE**. Limit adjustments are not necessary when the door opens and closes completely and does not reverse unintentionally in down direction.

The following chart outlines adjustment procedures. Run opener through a **COMPLETE TRAVEL CYCLE AFTER EACH ADJUSTMENT**. **NOTE: REPEATED OPERATION OF THE OPENER DURING ADJUSTMENT PROCEDURES MAY CAUSE THE MOTOR TO OVERHEAT AND SHUT OFF. SIMPLY WAIT 15 MINUTES AND TRY AGAIN.** Read the chart carefully before proceeding to Step 2. Use a screwdriver to make limit adjustments.

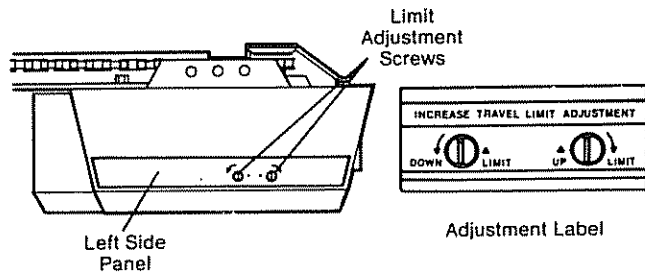

LIMIT ADJUSTMENT CHART

IF DOOR DOES NOT OPEN COMPLETELY BUT OPENS AT LEAST FIVE FEET

Increase UP travel. Turn UP LIMIT adjustment screw clockwise. One turn equals 2 inches of travel

If door doesn't open at least 5 feet: adjust OPEN FORCE as explained in Step 2.

IF DOOR DOES NOT CLOSE COMPLETELY (ON SECTIONAL DOORS)

Lengthen the door arm. (See Step 10, Page 16).

If door arm is at maximum length, increase DOWN travel. Turn down limit adjustment screw counter clockwise. One turn equals 2 inches of travel

If door still will not close completely, the header bracket is positioned too high. Repeat Step 1, Page 10

IF DOOR DOES NOT CLOSE COMPLETELY (ON ONE-PIECE DOORS)

Increase DOWN travel. Turn down limit adjustment screw counterclockwise. One turn equals 2 inches of travel.

IF DOOR REVERSES WHEN CLOSING AND THERE IS NO INTERFERENCE TO TRAVEL CYCLE

Test door for binding: Pull emergency release handle. Manually open and close door. If door is binding, call a door serviceman.

If door is not binding or unbalanced, adjust CLOSE FORCE. See Step 2.

IF OPENER REVERSES IN FULLY CLOSED POSITION

Decrease DOWN travel. Turn down limit adjustment screw clockwise. One turn equals 2 inches of travel.

STEP 2 Adjust Force



DO NOT USE FORCE ADJUSTMENTS TO COMPENSATE FOR A BINDING OR STICKING GARAGE DOOR. EXCESSIVE FORCE WILL INTERFERE WITH PROPER OPERATION OF SAFETY REVERSE SYSTEM OR DAMAGE GARAGE DOOR.

Force Adjustment Controls are located on rear panel of opener. **FORCE ADJUSTMENT** settings regulate amount of power required to open and close door.

NOTE: Door **STOPS** in UP direction if anything interferes with door travel. The door **REVERSES** in DOWN direction if anything interferes with door travel (including binding or unbalanced doors).

If force adjustments are set too light, door travel may be interrupted by nuisance reversals in DOWN direction and stops in UP direction. As weather conditions can affect door movement, occasional adjustment may be needed.

The maximum force adjustment range is 260 degrees, about 3/4 of a complete turn. Do not force controls beyond that point. Turn force adjustment controls with a screwdriver.

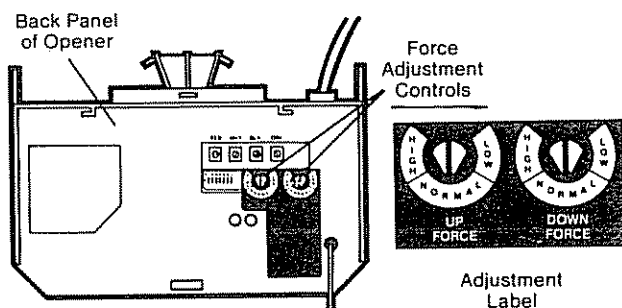

FORCE ADJUSTMENT CHART

TEST DOWN (CLOSE) FORCE

Grasp the door handle or door bottom when door is about halfway through DOWN (CLOSE) TRAVEL. The door should reverse. If the door is hard to hold or doesn't reverse, decrease the DOWN (CLOSE) FORCE by turning the control in a counter clockwise direction. Make 10 degree turn adjustments until the door reverses normally. After each adjustment, run the opener through a complete travel cycle

IF DOOR DOESN'T OPEN AT LEAST 5 FT

Increase UP (OPEN) FORCE by turning control clockwise. Make 10 degree turn adjustments until the door opens completely. Readjust UP LIMIT if necessary. After each adjustment, run opener through a complete travel cycle

IF DOOR REVERSES DURING DOWN (CLOSE) CYCLE

Increase DOWN (CLOSE) FORCE by turning control clockwise. Make 10 degree turn adjustments until the door completes close cycle. After each adjustment, run opener through a complete travel cycle.

Adjustment

STEP 3 Test Safety Reverse System



THE SAFETY REVERSE SYSTEM TEST IS IMPORTANT. THE GARAGE DOOR *MUST* REVERSE ON CONTACT WITH A ONE INCH OBSTACLE PLACED ON THE FLOOR. FAILURE TO PROPERLY ADJUST OPENER MAY RESULT IN SERIOUS PERSONAL INJURY FROM A CLOSING GARAGE DOOR. REPEAT TEST AT LEAST FOUR TIMES A YEAR AND ADJUST AS NEEDED.

PROCEDURE: Place a 1-inch obstacle on the floor under the garage door. Operate door in DOWN direction. The door must reverse on the obstruction.

If a **SECTIONAL** door STOPS on the obstruction, lengthen door arm until the door reverses in DOWN direction. (Refer to Step 10, FIG. C., Page 16. Fasten sections together to longest possible length).

If a **ONE-PIECE** door stops on obstruction, door is not traveling far enough in DOWN direction. Increase the DOWN limit by turning DOWN limit adjustment screw counterclockwise 1/4 turn. REPEAT TEST.

When the door reverses on the 1-inch obstruction, remove obstruction and run opener through a complete travel cycle. Door must not reverse in closed position. If it does, repeat Adjustment Steps 2 and 3.

SECTIONAL DOOR

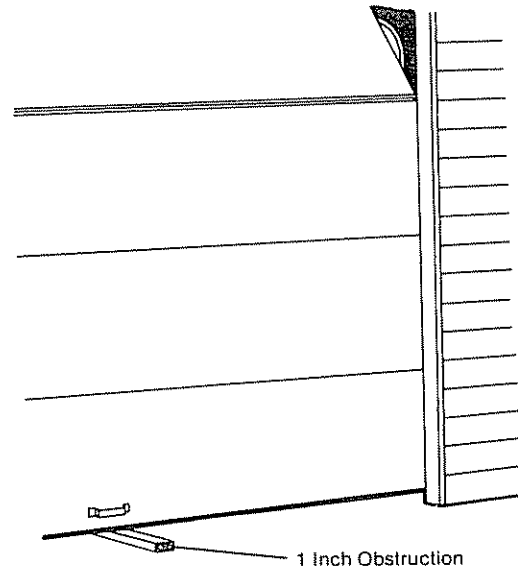

ONE-PIECE DOOR

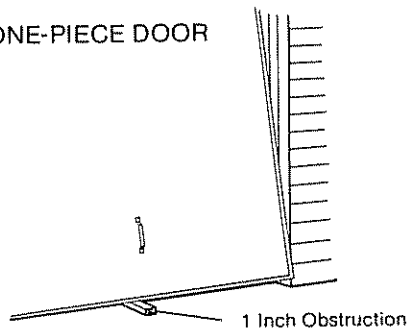

REPEAT ADJUSTMENT STEP 3 AFTER:

1. EACH ADJUSTMENT OF DOOR ARM LENGTH, CLOSE FORCE OR DOWN LIMIT.
2. ANY REPAIR OR ADJUSTMENT OF GARAGE DOOR (INCLUDING SPRINGS AND HARDWARE).
3. ANY REPAIR OR BUCKLING OF THE GARAGE FLOOR.
4. ANY REPAIR OR ADJUSTMENT OF THE GARAGE DOOR OPENER.

(Optional) STEP 4 Install Infrared Reversing System

The INFRARED REVERSING SENSOR provides an **ADDITIONAL** measure of safety against a small child being caught under a garage door. It uses an invisible beam which, when broken by an obstruction, causes a closing door to open and prevents an open door from closing.

After the garage door opener has been completely installed and adjusted, the INFRARED REVERSING SENSOR accessory can be installed. Instructions are included with this optional device.

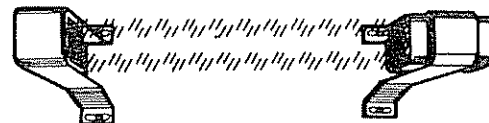

Radio Controls

Your 3-channel transmitter(s) will operate more than one garage door opener, if desired. Also, refer to the catalog packed with your opener for remote light products which can be operated by the additional push buttons on the transmitter(s).

Instructions are given below for changing codes and/or using the transmitter(s) with additional receivers.

PLEASE KEEP THIS INSTRUCTION MANUAL HANDY FOR FUTURE REFERENCE.

SETTING/CHANGING YOUR CODE IN RECEIVER(S) AND TRANSMITTER(S)



DISCONNECT POWER TO OPENER (OR OTHER DEVICES) BEFORE SETTING OR CHANGING THE CODE IN THE RECEIVER(S).

The TOP (Large) transmitter push button has been factory preset to operate the garage door opener. Each push button is programmed to operate by sliding RECEIVER code switch #1 to a specific position (+, - or 0). Detailed instructions are given below.

1. Decide which transmitter push button you want to use to operate a receiver.
2. Remove screw on back of transmitter(s). Carefully turn case over (push button side up).
3. Remove case top. **CAUTION: Be careful not to move circuit board components.**
4. Locate the RECEIVER code switch block.

- **TO USE TOP (LARGE) TRANSMITTER BUTTON:** Set RECEIVER code switch 1 to minus (-).
- **TO USE CENTER TRANSMITTER BUTTON:** Set RECEIVER code switch 1 to center (0).
- **TO USE BOTTOM TRANSMITTER BUTTON:** Set RECEIVER code switch 1 to plus (+).

TO SET THE CODE, use a pen or screwdriver. Begin with code switch 2 on the RECEIVER. Slide one or more of the switches to plus, minus or center (0).

Hold transmitter(s) alongside receiver code switch. Set code switches 2 through 9 in transmitter(s) to match receiver switch positions.

NOTE: Code switches 2 through 9 on ALL the receivers operated by the transmitter(s) must **MATCH** switches 2 through 9 in transmitter(s).

CAUTION: If you press more than ONE push button at the same time, transmitter will not operate.

TRANSMITTER

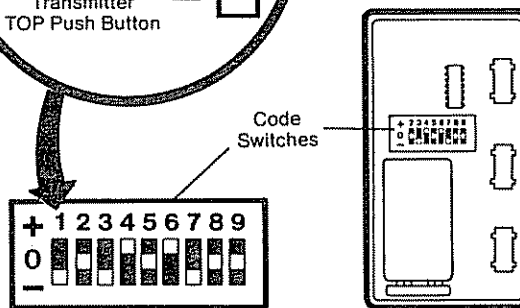
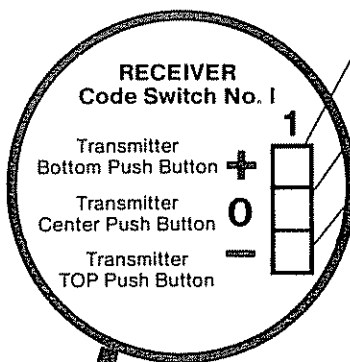
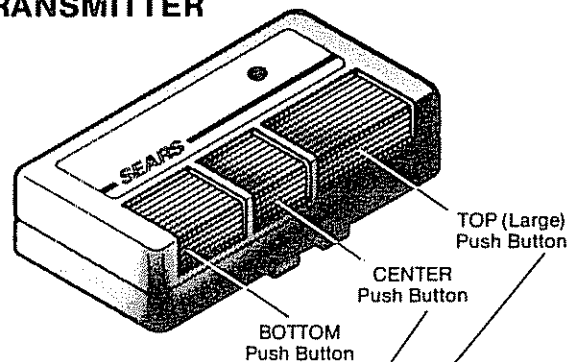

RECEIVER

TRANSMITTER

Having a Problem?

SITUATION	PROBABLE CAUSE & SOLUTION
OPENER DOESN'T OPERATE FROM EITHER WALL PUSH BUTTON OR TRANSMITTER	<ol style="list-style-type: none">1. Have you disengaged all door locks? Review Step 8, Page 14.2. Does the opener have electric power? Plug a lamp into the outlet. If it doesn't light, check fuse box or circuit breaker. (Some outlets are controlled by a wall switch).3. Repeated operation may have tripped the overload protector in the motor. Wait 15 minutes. Try again.4. Is there a build-up of ice or snow under door? Door may be frozen to ground. Remove any obstruction.5. Remove bell wire from opener terminals. Touch red and white screw terminals together with a jumper wire. If opener runs, check for a faulty wire connection at wall push button or a short under staples.
OPENER OPERATES FROM TRANSMITTER BUT NOT FROM WALL PUSH BUTTON	<ol style="list-style-type: none">1. Is wall push button lit? If not, refer to No. 5 above and follow same procedure.2. Are wiring connections correct? Review Step 6, Pg.13.
DOOR OPERATES FROM WALL PUSH BUTTON BUT NOT FROM THE TRANSMITTER	<ol style="list-style-type: none">1. Does the battery test light glow when transmitter push button is pressed?. If not, replace the battery (Page 5 tells you how.)2. If you have two transmitters and only one operates, review code setting procedures on Page 19. Receiver and ALL transmitters must be set to same code.3. Is transmitter(s) operating additional remote control devices? See code setting procedures on Page 19.4. Did you press transmitter button designated to operate garage door opener?5. Re-program receiver(s) and ALL transmitters. Try setting ALL the code switches in plus, center or minus positions. If transmitter(s) works, you can try a random code switch setting again, if you desire.
TRANSMITTER HAS SHORT RANGE	<ol style="list-style-type: none">1. Check battery test light. If the light is out, change the battery (Page 5 tells you how).2. Change the location of transmitter in the car.3. A metal garage door, foil-backed insulation or metal siding will reduce transmission range.4. Check to be sure the antenna on the back panel of the opener extends fully downward.
THE GARAGE DOOR OPENS AND CLOSES BY ITSELF	<ol style="list-style-type: none">1. Is there a neighbor with a garage door opener using the same frequency code? Change your code. Review Page 19.2. Check to make sure that the transmitter push button(s) is not stuck in the 'down' position.3. Remove bell wire from opener terminals and operate from transmitter only. If this solves the problem, the wall push button is faulty (replace), or there is a short or broken wire between push button and opener.
DOOR DOESN'T OPEN COMPLETELY	<ol style="list-style-type: none">1. Is something obstructing the door?2. If door opens at least 5 feet, travel limits may need to be increased. One turn equals 2 inches of travel. See Pg. 17. Repeat Safety Reverse Test after adjustment is complete.3. If door has been working properly but now doesn't open all the way, increase UP FORCE. See Pg. 17. Repeat Safety Reverse Test after adjustment is complete.
DOOR DOESN'T CLOSE COMPLETELY	<ol style="list-style-type: none">1. Review the Travel Limits Adjustment Chart on Page 17. Repeat Safety Reverse Test after any adjustment of door arm length, close force or down limit.

Having a Problem? (Continued)

SITUATION	PROBABLE CAUSE & SOLUTION
DOOR WON'T CLOSE	<ol style="list-style-type: none"> The infrared Reversing Sensor (if you have installed this accessory) may be misaligned or obstructed. Disconnect sensor and check door operation. If problem disappears, correct alignment.
DOOR REVERSES FOR NO APPARENT REASON	<ol style="list-style-type: none"> Is something obstructing the door? Pull red emergency release handle. Operate door manually. If it is unbalanced or binding, call a garage door serviceman to correct the problem. Clear any ice or snow from garage floor area where garage door closes. Review the Force Adjustment Chart on Page 17. Repeat Safety Reverse Test after adjustment is complete. If door reverses in FULLY CLOSED position, decrease travel limits (See Pg 17) and repeat Safety Reverse Test after adjustment is complete. THE NEED FOR OCCASIONAL ADJUSTMENT OF FORCE AND LIMIT SETTINGS IS NORMAL. WEATHER CONDITIONS IN PARTICULAR CAN AFFECT DOOR TRAVEL. The Infrared Reversing Sensor (if you have installed this accessory) may be misaligned or obstructed. Disconnect sensor and check door operation. If problem disappears, correct alignment.
OPENER LIGHT	<p>DOESN'T TURN ON</p> <ol style="list-style-type: none"> Replace the light bulb (75Watts Maximum) Use rough service bulbs if standard bulbs burn out prematurely due to vibration (Vibration may be caused by loose end panels. Retighten screws) <p>DOESN'T TURN OFF</p> <ol style="list-style-type: none"> There may be a defective ground at ceiling or wall receptacle. Unit must be grounded.
OPENER STRAINS OR MAXIMUM FORCE IS NEEDED TO OPERATE DOOR	<ol style="list-style-type: none"> Door may be out of balance. Use emergency release rope and handle to disconnect trolley. Open and close door manually. A properly balanced door will remain in any point of travel while being supported entirely by its springs. If it does not, call a garage door serviceman to correct problem.
OPENER MOTOR HUMS BRIEFLY, THEN WON'T RUN	<ol style="list-style-type: none"> Trolley may be jammed into rail stop bolts. Pull or push on door while motor is humming to release jammed condition. Re-adjust door limits (Page 17) to prevent over-travel. If problem occurs on the first operation during the installation process or after the chain was removed and re-installed, the motor may be out of phase. Remove chain; cycle motor to down position. (Observe the drive sprocket. When it turns in clockwise direction and stops, motor is in down position). Re-install chain.
OPENER WON'T OPERATE DUE TO POWER FAILURE	<ol style="list-style-type: none"> Use emergency release rope and handle to disconnect trolley. Door can be opened and closed manually. When the power is restored, press the wall push button and trolley will automatically reconnect The emergency release key lock accessory (for use on garages with no service door) disconnects the trolley from outside the garage in case of power failure.
CHAIN DROOPS OR SAGS	<ol style="list-style-type: none"> It is normal for the chain to droop slightly in closed door position. Use emergency release rope and handle to disconnect trolley. If chain returns to normal height when trolley is disengaged and door reverses on a one-inch obstruction, no adjustments are needed. See Page 9.

Repair Parts

RAIL ASSEMBLY PARTS LIST

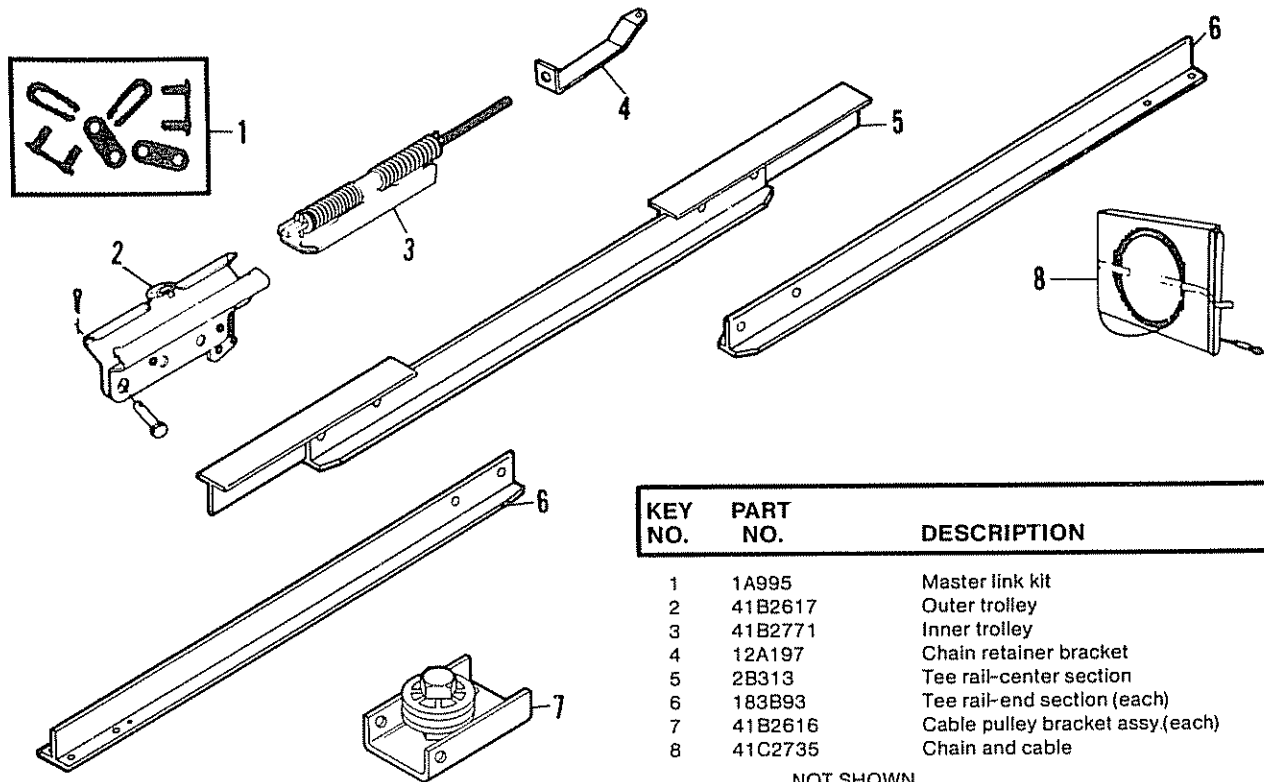

KEY NO.	PART NO.	DESCRIPTION
---------	----------	-------------

1	1A995	Master link kit
2	41B2617	Outer trolley
3	41B2771	Inner trolley
4	12A197	Chain retainer bracket
5	2B313	Tee rail-center section
6	183B93	Tee rail-end section (each)
7	41B2616	Cable pulley bracket assy.(each)
8	41C2735	Chain and cable

NOT SHOWN

41A2814 Rail assy hardware kit (includes hardware illustrated on Page 3)

INSTALLATION PARTS LIST

KEY NO.	PART NO.	DESCRIPTION
---------	----------	-------------

1	41D2736-1	Wall control assy
2	10A13	9 volt battery
3	41A3012	Transmitter case, cover and screw assy
4	29C121-2	Transmitter visor clip
5	41A2828	Emergency rope and handle assy
6	219A323	2-Strand bell wire
7	41A2829	Header bracket plus cotter pin and clevis
8	12B374	Door bracket
9	12B380	Door bracket plate
10	178B35	Curved door arm section
11	173B34	Straight door arm section
12	12B350	Hanging brackets

NOT SHOWN

41A2815 Installation hardware bag (includes hardware illustrated on Page 3)

114A976 Owners manual

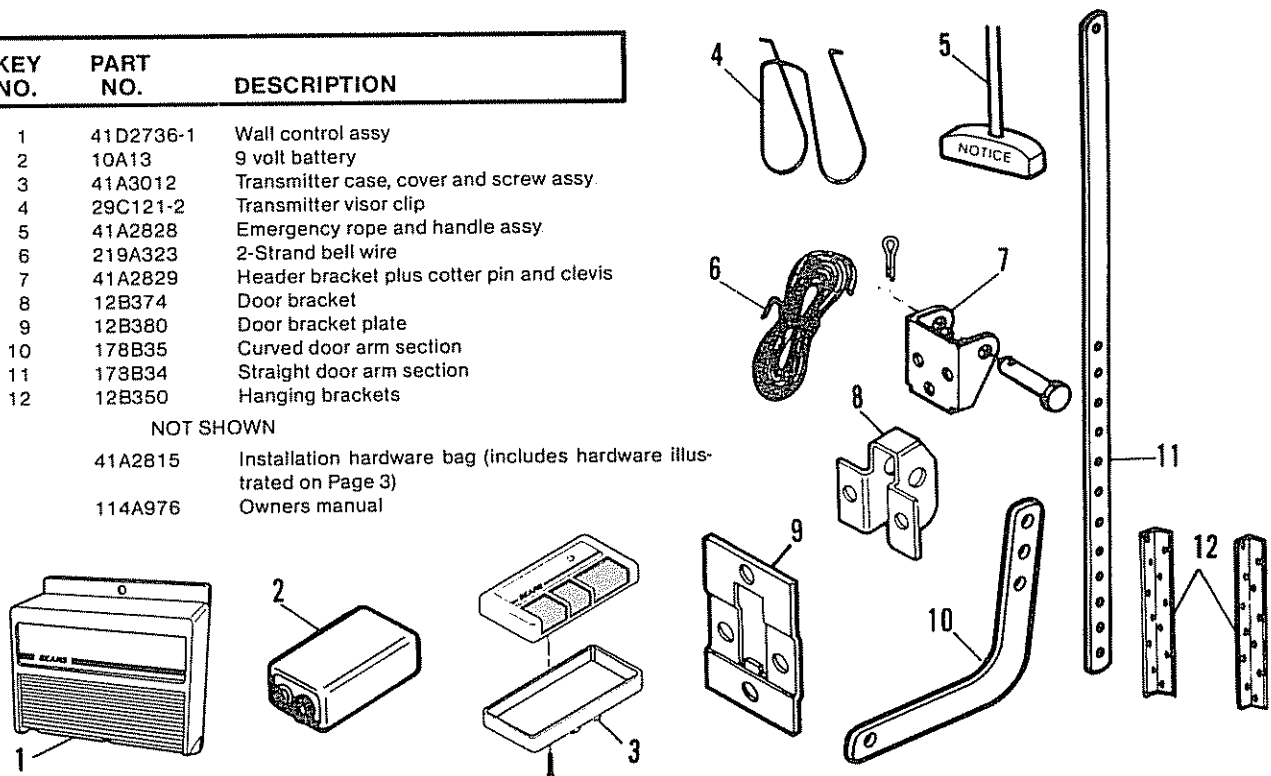

Repair Parts

Chassis Assembly Parts List

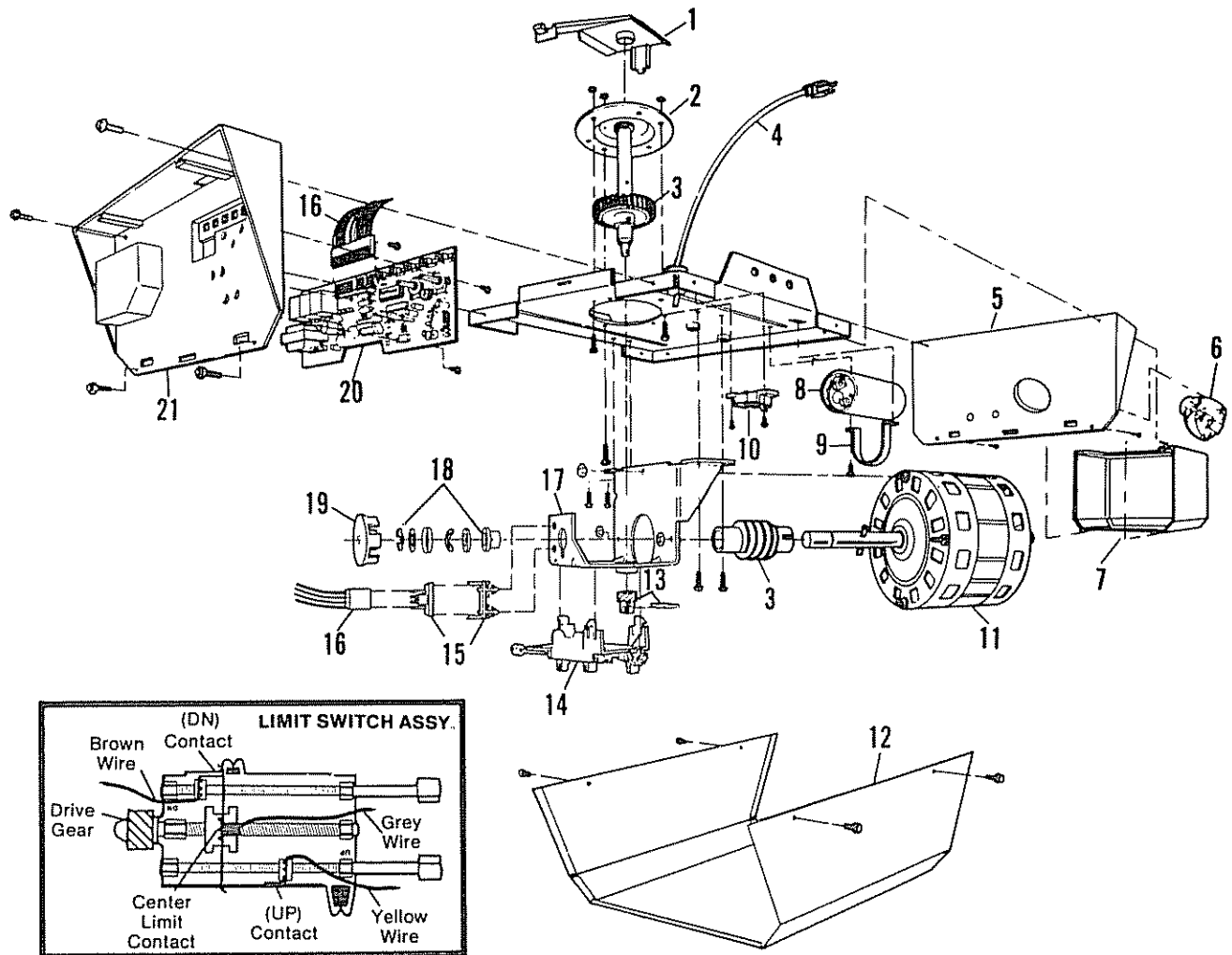

KEY PART NO. NO.	DESCRIPTION
------------------	-------------

1	31C290	Sprocket cover
2	41A2827	Gear and sprocket assy. Complete with: Spring washer Thrust washer Retaining ring Bearing plate Roll pins (2) Drive gear Worm gear Helical gear w/retainer Grease
3	41A2817	Drive/worm gear kit w/grease Roll pins (2)
4	41B2991	Line cord
5	41A3075	End panel
6	175B88	Light socket
7	108D30-1	Lens
8	30B387	Capacitor - 1/3h p
	30B363	Capacitor - 1/2h.p.
9	12A373	Capacitor bracket

KEY PART NO. NO.	DESCRIPTION
------------------	-------------

10	41A3150	Terminal block w/screws
11	41A2821	Universal replacement motor
12	41D2748-2	Cover - Model 139.53413 & Model 139.53606
	41D2748	Cover - Model 139.53403
13	41A2818	Helical gear & retainer w/grease
14	41D3013	Limit switch assembly
15	41C3005	RPM sensor assembly
16	41C2726	Wire harness assy. with plug
17	41A3027	Motor bracket and bearing assy.
18	41A2826	Shaft bearing kit
19	41A2822	Interrupter cup assy.
20	41A3066	Receiver logic board assy. Complete with: Logic board
21	41A3076	End panel w/all labels
	NOT SHOWN	
	41A2825	Chassis assy. hardware kit (includes screws not designated by number in illustration)

SEARS / CRAFTSMAN®

Owners Manual

**Garage
Door
Opener
Models:
139.53403
139.53413
139.53606
139.53610**

HOW TO ORDER REPAIR PARTS

Now that you have purchased your Sears Garage Door Opener, should you ever need repair parts or service, simply contact any Sears Service Center and most Sears, Roebuck and Co. stores. Be sure to provide all pertinent facts when you call or visit.

The MODEL NUMBER of your garage door opener is printed on a label located on the front panel of the opener chassis.

All parts listed may be ordered from any service center and most Sears stores.

WHEN ORDERING REPAIR PARTS, ALWAYS GIVE THE FOLLOWING INFORMATION:

- PART NUMBER
- PART DESCRIPTION
- MODEL NUMBER
- NAME OF ITEM

If the parts you need are not stocked locally, your order will be electronically transmitted to a Sears Repair Parts Distribution Center for handling.

IMPORTANT NOTE: If you suspect radio control malfunction, contact your nearest SEARS Service Center.

MAINTENANCE AGREEMENTS ... YOUR WAY TO BUY TOMORROW'S SERVICE

AT TODAY'S PRICE ... With nationwide service and the benefits of a Sears warranty plus a Sears Maintenance Agreement, you don't have to worry about costly repairs resulting from normal use.

The Maintenance Agreement does not cover installation or re-installation of the product or damage resulting from external causes such as: acts of abuse, fire, flood, wind, lightning, freezing, etc.

To Purchase a Sears Maintenance Agreement - Ask Any Salesperson or Call Sears Service Today.

SEARS WARRANTY

FULL 90 DAY WARRANTY ON GARAGE DOOR OPENER

For 90 days from the date of purchase, Sears will repair this Garage Door Opener, free of charge, if defective in material or workmanship.

LIMITED WARRANTY

From the 91st day until one year from the date of purchase, Sears will furnish replacement parts for any defective parts, free of charge. You pay for labor.

LIMITED WARRANTY ON 1/2 HP AND 1/3 HP MOTORS FOR CRAFTSMAN OPENERS

1/2hp Motor: After 1 year and through 5 years, if the motor on this Garage Door Opener is defective, Sears will furnish a replacement motor, free of charge. You pay for labor.

1/3hp Motor: After 1 year and through 3 years, if the motor on this Garage Door Opener is defective, Sears will furnish a replacement motor, free of charge. You pay for labor.

LIMITATION ON LIABILITY

Sears will not be liable for loss or damage to property or any incidental or consequential loss or expense from property damage due directly or indirectly from the use of this product.

Some states do not allow the exclusion or limitation of incidental or consequential damages, so the above limitation or exclusion may not apply to you.

This warranty does not cover repairs necessary because of operator abuse or negligence, including the failure to install, adjust and operate this garage door opener according to the instructions contained in the owner's manual.

WARRANTY SERVICE IS AVAILABLE BY SIMPLY CONTACTING THE NEAREST SEARS SERVICE CENTER/DEPARTMENT IN THE UNITED STATES. This warranty applies only while the product is in use in the United States.

This warranty gives you specific legal rights, and you may also have other rights which vary from state to state.

SEARS ROEBUCK AND CO., Dept. 698/731A Sears Tower, Chicago, IL 60684