

Use and Care Guide



Liquid Propane Gas Grill

Model No. 415.16661800

This Grill Is For
Outdoor Use Only



WARNING

- Read this manual before cooking on grill. Failure to follow all manufacturer's instructions could result in fire or explosion which could cause property damage, personal injury or death.
- Combustion by-products produced when using this product contain chemicals known to the State of California to cause cancer, birth defects, or other reproductive harm.

CAUTION

- Read and follow all Safety Statements, Assembly Instructions and Use & Care Directions before attempting to assemble and cook.
- Some parts may contain sharp edges, especially as noted in these instructions. Wear protective gloves if necessary.

- Parts
- Assembly
- Safety Rules
- Use and Care
- Troubleshooting

Assembly Questions?
Call 1-800-241-7548

Parts Ordering:
Call 1-800-4-MY-HOME®

To Installer/Assembler: Leave these instructions with consumer.

To Consumer: Keep this manual for future reference.

Sears, Roebuck and Co., Hoffman Estates, IL 60179 U.S.A.



DANGER



If you smell gas:

1. Shut off gas to the appliance.
2. Extinguish any open flame.
3. Open lid.
4. If odor continues, keep away from the appliance and immediately call your gas supplier or your fire department.



WARNING



1. Do not store or use gasoline or other flammable liquids or vapors in the vicinity of this or any other appliance.
2. An LP Tank not connected for use shall not be stored in the vicinity of this or any other appliance.

Call Grill Service Center For Help And Parts

If you have questions or need assistance during assembly, please call **1-800-241-7548**. You will be speaking to a representative of the grill manufacturer and not a Sears employee. To order new parts call Sears at **1-800-4-MY-HOME®**.

Product Record

IMPORTANT: Fill out the product record information below.

Model Number _____

Serial Number _____
See rating label on grill for serial number.

Date Purchased _____



CAUTION



For residential use only. Do not use for commercial cooking.



WARNING



CALIFORNIA PROPOSITION 65

1. Combustion by-products produced when using this product contain chemicals known to the State of California to cause cancer, birth defects, and other reproductive harm.
2. This product contains chemicals, including lead and lead compounds, known to the State of California to cause cancer, birth defects or other reproductive harm.

Wash your hands after handling this product.

Installation Safety Precautions

- Use grill, as purchased, only with LP (propane) gas and the regulator/valve assembly supplied.
- Grill installation must conform with local codes, or in the absence of local codes, with either the *National Fuel Gas Code, ANSI Z223.1/NFPA 54, Natural Gas and Propane Installation Code, CSA B149.1, or Propane Storage and Handling Code, B149.2, or the Standard for Recreational Vehicles, ANSI A 119.2/NFPA 1192, and CSA Z240 RV Series, Recreational Vehicle Code, as applicable.*
- All electrical accessories (such as rotisserie) must be electrically grounded in accordance with local codes, or *National Electrical Code, ANSI / NFPA 70 or Canadian Electrical Code, CSA C22.1.* Keep any electrical cords and/or fuel supply hoses away from any hot surfaces.
- Grill is not for use in or on recreational vehicles and/or boats.
- This grill is safety certified for use in the United States and/or Canada only. Do not modify for use in any other location. Modification will result in a safety hazard.

Safety Symbols

The symbols and boxes shown below explain what each heading means. Read and follow all of the messages found throughout the manual.



DANGER



DANGER: Indicates an imminently hazardous situation which, if not avoided, will result in death or serious injury.



WARNING



WARNING: Be alert to the possibility of serious bodily injury if the instructions are not followed. Be sure to read and carefully follow all of the messages.



CAUTION



CAUTION: Indicates a potentially hazardous situation which, if not avoided, may result in minor or moderate injury.

TABLE OF CONTENTS

For Your Safety	2
Grill Service Center	2
Product Record Information	2
Safety Symbols	2
Installation Safety Precautions	2
Kenmore Elite Grill Warranty	3
Use and Care	4-11
Parts List	12
Parts Diagram	13
Assembly	14-28
Troubleshooting	29-31

Repair Protection Agreements

Congratulations on making a smart purchase. Your new Kenmore® product is designed and manufactured for years of dependable operation. But like all products, it may require repair from time to time. That's when having a Repair Protection Agreement can save you money and aggravation.

Here's what the Repair Protection Agreement* includes:

- ✓ **Expert service** by our 10,000 professional repair specialists
- ✓ **Unlimited service and no charge** for parts and labor on all covered repairs
- ✓ **Product replacement** up to \$1500 if your covered product can't be fixed
- ✓ **Discount of 10%** from regular price of service and related installed parts not covered by the agreement; also, 10% off regular price of preventive maintenance check
- ✓ **Fast help by phone** – we call it Rapid Resolution – phone support from a Sears representative. Think of us as a “talking owner's manual.”

Once you purchase the Repair Protection Agreement, a simple phone call is all that it takes for you to schedule service. You can call anytime day or night, or schedule a service appointment online.

The Repair Protection Agreement is a risk-free purchase. If you cancel for any reason during the product warranty period, we will provide a full refund. Or, a prorated refund anytime after the product warranty period expires. Purchase your Repair Protection Agreement today!

Some limitations and exclusions apply. For prices and additional information in the U.S.A. call 1-800-827-6655.

***Coverage in Canada varies on some items. For full details call Sears Canada at 1-800-361-6665.**

Sears Installation Service

For Sears professional installation of home appliances, garage door openers, water heaters, and other major home items, in the U.S.A. or Canada call **1-800-4-MY-HOME®**.

WARRANTY

KENMORE ELITE FULL WARRANTY

If this grill fails due to a defect in material or workmanship within one year from the date of purchase, call 1-800-4-MY-HOME® to arrange for free repair (or replacement if repair proves impossible).

Limited Warranty on Stainless Steel Burners

Any stainless steel burner that ever rusts through will be replaced free of charge. After the first year from the date of purchase you must pay the labor cost if you wish to have it installed.

Limited Warranty on Selected Grill Parts

From the date of purchase for the time periods listed below, the following specific grill parts will be replaced free of charge if they rust through. After the first year from the date of purchase you must pay the labor cost if you wish to have them installed.

Stainless Steel Parts	10 Years (except Burners, see above)
Painted Steel Parts	3 Years
Cooking Grids	2 Years
Heat Diffusers	2 Years

All warranty coverage excludes batteries and any grill part paint loss or rusting (except for rust-through as specified above), which are either expendable parts that can wear out from normal use in less than a year, or are conditions that can be the result of normal use, accident or improper maintenance.

All warranty coverage is void if this grill is used for commercial or rental purposes.

All warranty coverage applies only if this grill is used in the United States.

This warranty gives you specific legal rights, and you may also have other rights which vary from state to state.

Sears, Roebuck and Co., Hoffman Estates, IL 60179



CONVERSION-READY

Easily converts from (LP) liquid propane to (NG) natural gas

Contact 1-800-4-MY-HOME or www.sears.com/parts to purchase a natural gas conversion kit. Request Part number 415.4584609

USE AND CARE



DANGER



- **NEVER** store a spare LP tank under or near grill or in enclosed areas

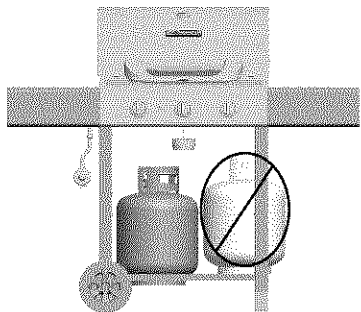

- Never fill the tank beyond 80% full.
- An overfilled or improperly stored tank is a hazard due to possible gas release from the safety relief valve.
- If you see, smell or hear escaping gas, immediately get away from the LP tank/grill and call your fire department.
- If the above is not followed exactly, a fire causing death or serious injury may occur.

LP Tank Removal, Transport And Storage

- Turn OFF all control knobs and LP tank valve. Turn coupling nut counterclockwise by hand only - do not use tools to disconnect. Lift LP tank wire upward off of LP tank collar, then lift LP tank up and off of support bracket. Install safety cap onto LP tank valve. Always use cap and strap supplied with valve. **Failure to use safety cap as directed may result in serious personal injury and/or property damage.**

LP Tank Valve

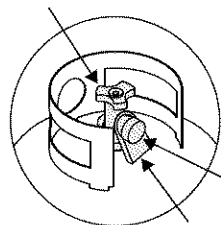

Safety Cap

Retainer Strap

- A disconnected LP tank in storage or being transported must have a safety cap installed (as shown). Do not store an LP tank in enclosed spaces such as a carport, garage, porch, covered patio or other building. Never leave an LP tank inside a vehicle which may become overheated by the sun.
- Do not store an LP tank in an area where children play.

LP Tank

- The LP Tank used with your grill must meet the following requirements:
- Use LP Tanks only with these required measurements: 12" (30.5cm) (diameter) x 18" (45.7 cm) (tall) with 20 lb. (9 kg.) capacity maximum.
- LP Tanks must be constructed and marked in accordance with specifications for LP Tanks of the U.S. Department of Transportation (DOT) or for Canada, CAN/CSA-B339, tanks, spheres and tubes for transportation of dangerous goods. Transport Canada (TC). See LP Tank collar for marking.
- LP Tank valve must have:
 - Type 1 outlet compatible with regulator or grill.
 - Safety relief valve.
 - UL listed Overfill Protection Device (OPD). This OPD safety feature is identified by a unique triangular hand wheel. **Use only LP Tanks equipped with this type of valve.**
- LP Tank must be arranged for vapor withdrawal and include collar to protect LP Tank valve. Always keep LP Tanks in upright position during use, transit or storage.

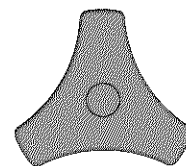

OPD Hand Wheel

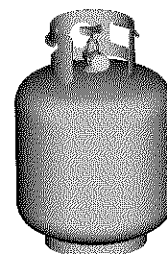

LP Tank in upright position for vapor withdrawal

LP (Liquefied Petroleum Gas)

- LP gas is nontoxic, odorless and colorless when produced. **For Your Safety**, LP gas has been given an odor (similar to rotten cabbage) so that it can be smelled.
- LP gas is highly flammable and may ignite unexpectedly when mixed with air.

LP Tank Filling

- Use only licensed and experienced dealers.
- LP dealer **must purge new tank** before filling.
- Dealer should **NEVER** fill LP Tank more than 80% of LP Tank volume. Volume of propane in tank will vary by temperature.
- A frosty regulator indicates gas overfill. Immediately close LP Tank valve and call local LP gas dealer for assistance.
- Do not release liquid propane (LP) gas into the atmosphere. This is a hazardous practice.
- To remove gas from LP Tank, contact an LP dealer or call a local fire department for assistance. Check the telephone directory under "Gas Companies" for nearest certified LP dealers.

LP Tank Exchange

- Many retailers that sell grills offer you the option of replacing your empty LP tank through an exchange service. Use only those reputable exchange companies that inspect, precision fill, test and certify their tanks. **Exchange your tank only for an OPD safety feature-equipped tank as described in the "LP Tank" section of this manual.**
- Always keep new and exchanged LP tanks in upright position during use, transit or storage.
- **Leak test new and exchanged LP tanks BEFORE connecting to grill.**

LP Tank Leak Test

For your safety

- Leak test must be repeated each time LP tank is exchanged or refilled.
- Do not smoke during leak test.
- Do not use an open flame to check for gas leaks.
- Grill must be leak tested outdoors in a well-ventilated area, away from ignition sources such as gas fired or electrical appliances. During leak test, keep grill away from open flames or sparks.
- Use a clean paintbrush and a 50/50 mild soap and water solution. Brush soapy solution onto areas indicated by arrows in figure below. Leaks are indicated by growing bubbles.

	WARNING	
If "growing" bubbles appear do not use or move the LP tank. Contact an LP gas supplier or your fire department!		

- ▲ **Do not use household cleaning agents.** Damage to gas train components can result.

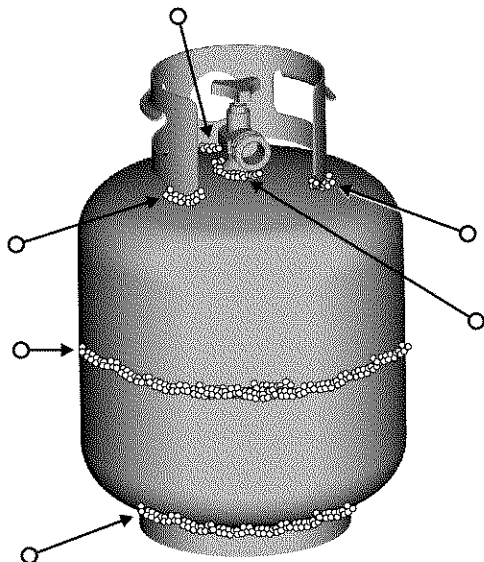

Connecting Regulator To The LP Tank

1. LP tank must be properly secured onto grill. (Refer to assembly section.)
2. Turn all control knobs to the OFF position.
3. Turn LP tank OFF by turning OPD hand wheel clockwise to a full stop.
4. Remove the protective cap from LP tank valve. Always use cap and strap supplied with valve.

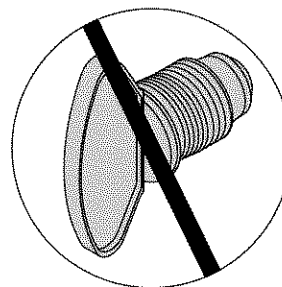
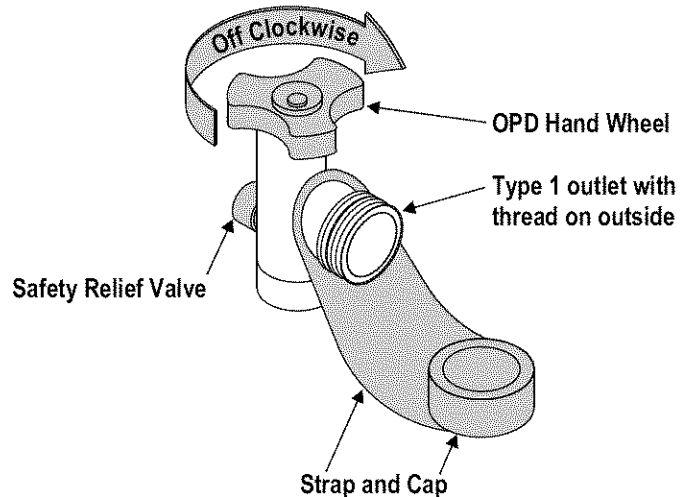

Do not use a POL transport plug (plastic part with external threads)! It will defeat the safety feature of the valve.

5. Hold regulator and insert nipple into LP tank valve. Hand-tighten the coupling nut, holding regulator in a straight line with LP tank valve so as not to cross-thread the connection.

Nipple has to be centered into the LP tank valve.

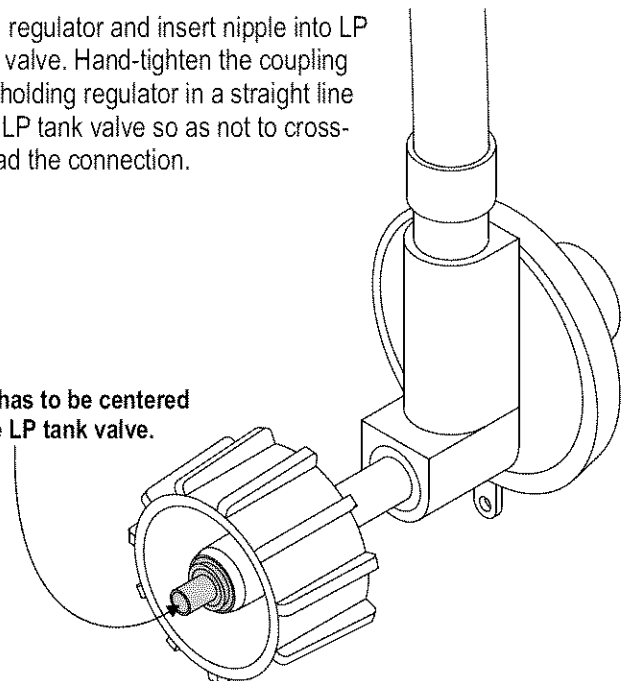

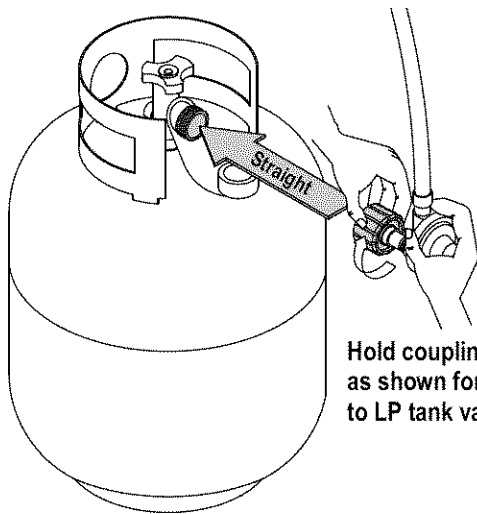

Hold coupling nut and regulator as shown for proper connection to LP tank valve.

6. Turn the coupling nut clockwise and tighten to a full stop. The regulator will seal on the back-check feature in the LP tank valve, resulting in some resistance. **An additional one-half to three-quarters turn is required to complete the connection. Tighten by hand only – do not use tools.**

NOTE:

If you cannot complete the connection, disconnect regulator and repeat steps 5 and 6. If you are still unable to complete the connection, **do not use this regulator!**

	DANGER	
<ul style="list-style-type: none"> • Do not insert any tool or foreign objects into the valve outlet or safety relief valve. You may damage the valve and cause a leak. Leaking propane may result in explosion, fire, severe personal injury, or death.. • If a leak is detected at any time, STOP and call the fire department. • If you cannot stop a gas leak, <i>immediately</i> close LP tank valve and call LP gas supplier or your fire department! 		

	WARNING	
<ul style="list-style-type: none"> • Never attempt to attach this grill to the self-contained LP gas system of a camper trailer or motor home. • Do not use grill until leak-tested. 		

Leak Testing Valves, Hose and Regulator

1. Turn all grill control knobs to OFF.
2. Be sure regulator is tightly connected to LP tank.
3. Completely open LP tank valve by turning OPD hand wheel counterclockwise. If you hear a *rushing sound*, turn gas off immediately. There is a major leak at the connection. **Correct before proceeding** by calling Sears for replacement parts at 1-800-4-MY-HOME®.
4. Brush soapy solution onto areas where bubbles are shown in picture below:

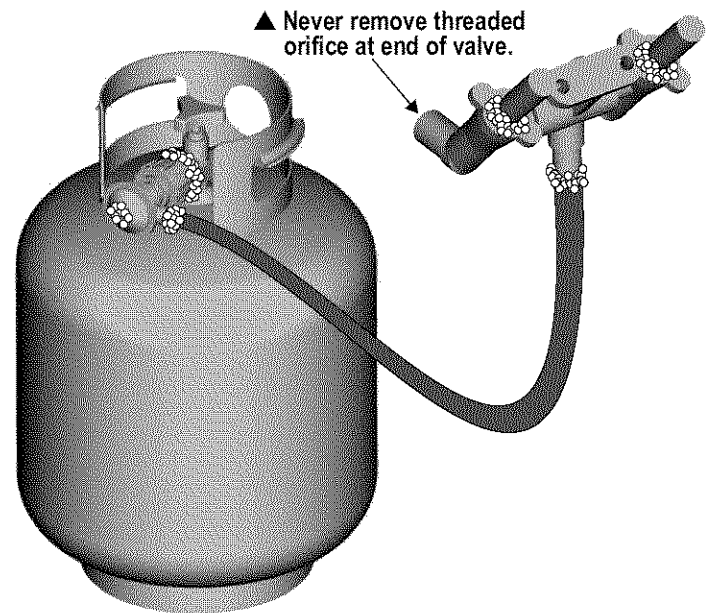

5. If “growing” bubbles appear, there is a leak. Close LP tank valve immediately and retighten connections. **If leaks cannot be stopped do not try to repair.** Call Sears for replacement parts at 1-800-4-MY-HOME®.
6. Always close LP tank valve after performing leak test by turning hand wheel clockwise.



WARNING



For Safe Use Of Your Grill And To Avoid Serious Injury:

- Do not let children operate or play near grill.
- Keep grill area clear and free from materials that burn.
- Do not block holes in bottom or back of grill.
- Check burner flames regularly.
- Use grill only in well-ventilated space. NEVER use in enclosed space such as carport, garage, porch, covered patio, or under an overhead structure of any kind.
- Do not use charcoal or ceramic briquets in a gas grill. *(Unless briquets are supplied with your grill.)*
- **Use grill at least 3 ft. from any wall or surface.** Maintain 10 ft. clearance to objects that can catch fire or sources of ignition such as pilot lights on water heaters, live electrical appliances, etc.

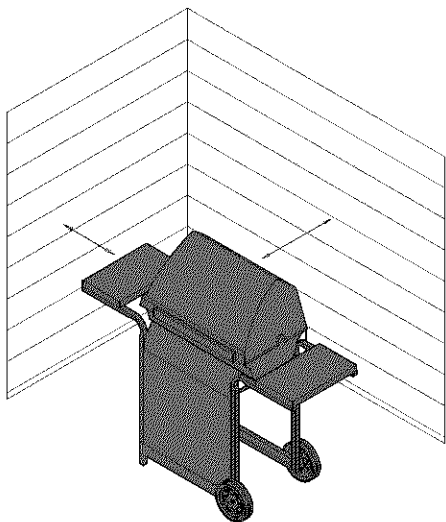

• Apartment Dwellers:

Check with management to learn the requirements and fire codes for using an LP gas grill in your apartment complex. If allowed, use outside on the ground floor with a three (3) foot clearance from walls or rails. Do not use on or under balconies.

- **NEVER attempt to light burner with lid closed.** A buildup of non-ignited gas inside a closed grill is hazardous.
- **Never operate grill with LP tank out of correct position specified in assembly instructions.**
- **Always close LP tank valve and remove coupling nut before moving LP tank from specified operation position.**

Safety Tips

- ▲ Before opening LP tank valve, check the coupling nut for tightness.
- ▲ When grill is not in use, turn off all control knobs and LP tank valve.
- ▲ Never move grill while in operation or still hot.
- ▲ Use long-handled barbecue utensils and oven mitts to avoid burns and splatters.
- ▲ Maximum load for shelves is 10 lbs.
- ▲ Do not use a cooking pot larger than 9" on grid.
- ▲ The grease tray **must** be installed into opening in back panel and should be emptied after each use. Do not remove grease tray until grill has completely cooled.
- ▲ If you notice grease or other hot material dripping from grill onto valve, hose or regulator, turn off gas supply at once. Determine the cause, correct it, then clean and inspect valve, hose and regulator before continuing. Perform a leak test.
- ▲ The regulator may make a humming or whistling noise during operation. This will not affect safety or use of grill.
- ▲ If you have a grill problem see the "Troubleshooting Section".



WARNING



If the regulator frosts, turn off grill and LP tank valve immediately. This indicates a problem with the tank and it should not be used on any product. Return to supplier!

Main Burner Ignitor Lighting

- ▲ **Do not lean over grill while lighting.**
1. **Open lid during lighting.**
 2. Turn ON gas valve from source or tank.
 3. Push and turn burner control knob to  and you will hear a clicking sound as the burner is being ignited.
 4. If ignition does NOT occur in 5 seconds, turn the burner control knob OFF, wait 5 minutes for gas to clear, and repeat the lighting procedure.
 5. Repeat above steps to light each burner individually. After lighting: Turn knobs to HI position for 15 minutes to pre heat the grill. Then turn knobs to desired setting for cooking.
 6. Important: When using the rotisserie burner, do not use the main burners.



CAUTION



If burner does not light, turn knobs to OFF, wait 5 minutes, and try again. Always close valve during the 5 minute waiting period. If the burner does not ignite with the valve open, gas will continue to flow out of the burner and could accidentally ignite with risk of injury.

Main Burner Match Lighting

▲ Do not lean over grill while lighting.

1. Open lid during lighting.
2. Place match into match holder (hanging from side of cart). Light match, place into lighting hole on right side of firebox.
3. Push in and turn right knob to HI position. Be sure burner lights and stays lit.
4. If ignition does NOT occur in 5 seconds, turn the burner control knob OFF, wait 5 minutes for gas to clear, and repeat the lighting procedure.
5. Light other burners by pushing knob in and turning to HI position. After lighting: Leave knobs in HI position for 15 minutes to pre heat the grill. Then turn knobs to desired setting for cooking.

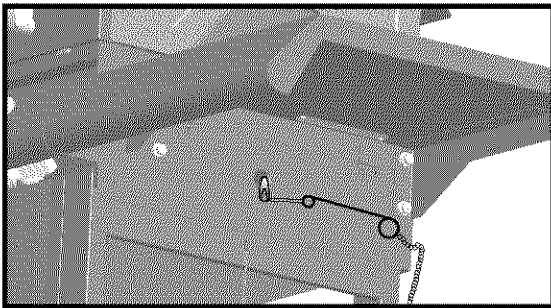

Side Burner Ignitor Lighting

▲ Do not lean over grill while lighting.

1. Open lid during lighting. Turn on gas at LP Tank.
2. Turn sideburner knob to ⚡, and you will hear a clicking sound as the burner is being ignited.
3. If ignition does NOT occur in 5 seconds, turn the burner control OFF. Wait 5 minutes for gas to clear, and repeat lighting procedure.

Side Burner Match Lighting

▲ Do not lean over grill while lighting.

1. Open lid during lighting. Turn on gas at LP Tank.
2. Place lit match near burner.
3. Turn sideburner knob to HIGH position. Be sure burner lights and stays lit.
4. If ignition does NOT occur in 5 seconds, turn the burner control knob OFF, wait 5 minutes for gas to clear, and repeat the lighting procedure.

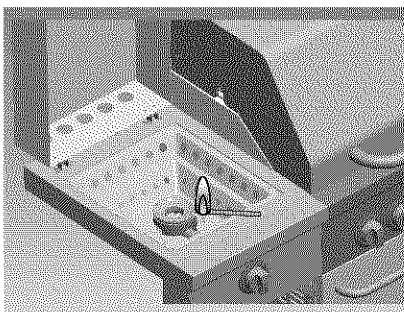

Rotisserie Burner Ignitor Lighting

▲ Do not lean over grill while lighting.

1. Turn OFF all gas burner control valves.
2. OPEN lid during lighting.
3. To ignite, turn the rotisserie knob to ⚡, and you will hear a clicking sound as the burner is being ignited.
4. If ignition does NOT occur in 5 seconds, turn the burner controls to OFF, wait 5 minutes for gas to clear, and repeat the lighting procedure.

If ignition still does not occur, follow match-lighting instructions.

Rotisserie Burner Match Lighting

▲ Do not lean over grill while lighting.

1. Open lid during lighting. Turn on gas at LP Tank.
2. Place lit match into rotisserie match lighting hole.
3. Turn rotisserie burner knob to HIGH position. Be sure burner lights and stays lit.
4. If ignition does NOT occur in 5 seconds, turn the burner controls to OFF, wait 5 minutes for gas to clear, and repeat the lighting procedure.

Rotisserie Match lighting hole

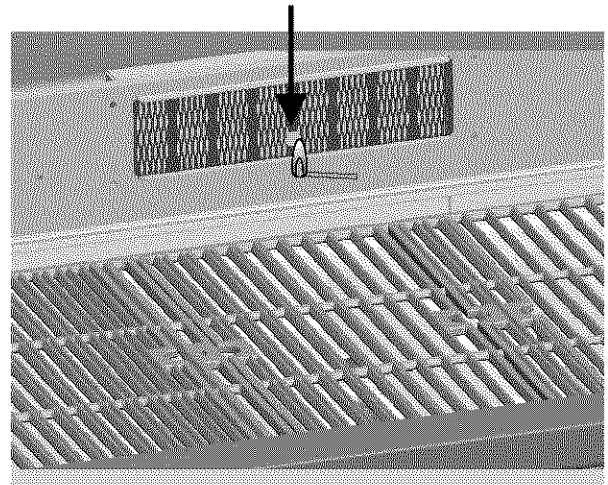

CAUTION



- Putting out grease fires by closing the lid is not possible. Grills are well ventilated for safety reasons.
- Do not use water on a grease fire. Personal injury may result. If a grease fire develops, turn knobs and LP tank off.
- Do not leave grill unattended while preheating or burning off food residue on high. If grill has not been regularly cleaned, a grease fire can occur that may damage the product. Follow instructions on General Grill Cleaning and Cleaning The Burner Assembly to prevent grease fires.

Before Your First Cookout

- Light burners, check to make sure they are lit, close the lid and warm up grill on HIGH for 15 minutes. This curing of paint and parts will produce an odor only on first lighting.

Burner Flame Check

- Light burner, rotate knobs from HIGH to LOW. You should see a smaller flame in LOW position than seen on HIGH. Always check flame prior to each use. If only low flame is seen refer to "Sudden drop or low flame" in the *Troubleshooting Section*.

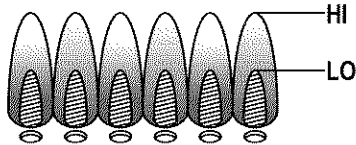

Hose Check

- Before each use, check to see if hoses are cut, worn or kinked. Replace damaged hoses before using grill. Use only valve/hose/regulator specified in the Parts List.

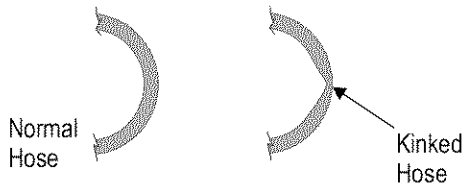

Turning Grill Off

- Turn all knobs to **OFF** position. Turn LP tank off by turning OPD hand wheel clockwise to a full stop.

Ignitor Check

- Turn gas off at LP tank. Push and turn burner control to ⚡. "Clicking" should be heard and sparking seen each time between collector box or burner and electrodes. See "Troubleshooting" if no click or spark occurs.

Valve Check

- **Important: Make sure gas is off at LP tank before checking valves.** Knobs lock in **OFF** position. To check valves, first push in knobs and release, knobs should spring back. If knobs do not spring back, replace valve assembly before using grill. Turn knobs to **LO** position then turn back to **OFF** position. Valves should turn smoothly.

General Grill Cleaning

- Keep the outside of your grill looking new by cleaning it once a month with warm soap and water or a non-abrasive cleaner. If you don't have a grill cover, wipe off dust and grime before starting your grill.
- Coating the cooking grids with spray-on cooking oil will keep the food from sticking and make clean up easier. After cooking, scrape the grates with a long handled, brass wire bristle brush.
- Check inside the grill bottom for grease build up and clean often, especially after cooking fatty meat.
- Do not mistake brown or black accumulation of grease and smoke for paint. Apply a strong solution of detergent and water or use a grill cleaner with scrub brush on insides of grill lid and bottom. Rinse and allow to completely air dry. **Do not apply a caustic grill/oven cleaner to painted surfaces.**

- **Plated wire grates:** Wash grates with concentrated grill cleaner or use soap and water solution. Dry thoroughly and store indoors between cookouts.
- **Plastic parts:** Wash with warm soapy water and wipe dry.
 - ▲ Do not use citrisol, abrasive cleaners, degreasers or a concentrated grill cleaner on plastic parts. Damage to and failure of parts can result.
- **Porcelain grates:** Because of glass-like composition, most residue can be wiped away with baking soda/water solution or specially formulated cleaner. Use non-abrasive scouring powder for stubborn stains.
- **Cooking surfaces:** If a bristle brush is used to clean any of the grill cooking surfaces, ensure no loose bristles remain on cooking surfaces prior to grilling. It is not recommended to clean cooking surfaces while grill is hot.



SPIDER ALERT!

SPIDER AND WEBS
INSIDE BURNER TUBE

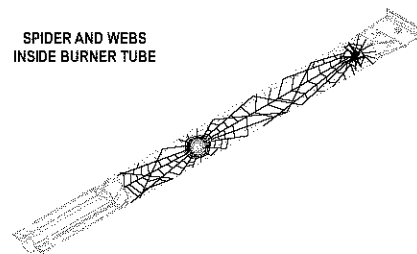

If you notice that your grill is getting hard to light or that the flame isn't as strong as it should be, take the time to check and clean the burners.

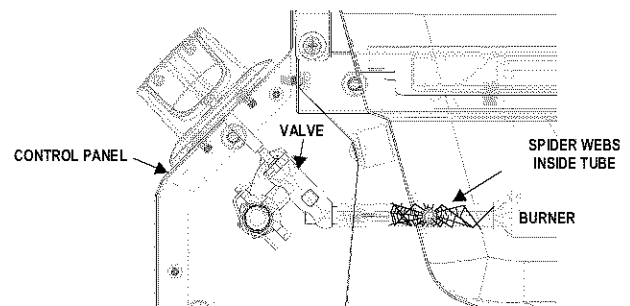

In some areas of the country, spiders or small insects have been known to create "flashback" problems. The spiders spin webs, build nests and lay eggs in the grill's burner tube(s) obstructing the flow of gas to the burner. The backed-up gas can ignite in the tube behind the control panel. This is known as a flashback and it can damage your grill and even cause injury.

To prevent flashbacks and ensure good performance the burner assembly should be removed from the grill and cleaned before use whenever the grill has been idle for an extended period.

Cleaning the Burner Assembly

Follow these instructions to clean and/or replace parts of burner assembly or if you have trouble igniting grill.

1. Turn gas off at control knobs and LP Tank.
2. Remove cooking grates and heat diffusers.
3. Remove screws and flame carryover tubes from rear of burners.
4. Remove screw and washers to disengage burner from bracket on firebox.
5. Remove screws to detach electrode from burner. Electrode should remain in firebox.
6. Carefully lift each burner up and away from valve openings.

We suggest three ways to clean the burner tubes. Use the one easiest for you.

- (A) Bend a stiff wire (a light weight coat hanger works well) into a small hook. Run the hook through each burner tube several times.



- (B) Use a narrow bottle brush with a flexible handle (do not use a brass wire brush), run the brush through each burner tube several times.

- (C) **Wear eye protection:** Use an air hose to force air into the burner tube and out the burner ports. Check each port to make sure air comes out each hole.

7. Wire brush entire outer surface of burner to remove food residue and dirt.
8. Clean any blocked ports with a stiff wire such as an open paper clip.
9. Check burner for damage, due to normal wear and corrosion some holes may become enlarged. If any large cracks or holes are found replace burner.

VERY IMPORTANT: Burner tubes must re-engage valve openings. See illustrations at right.

10. Attach electrode to burner.
11. Carefully replace burners.
12. Attach burners to brackets on firebox.
13. Reposition flame carryover tubes and attach to burners. Replace heat tents and cooking grates.

Correct
burner-to-valve
engagement

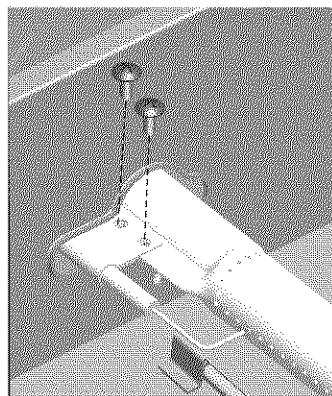
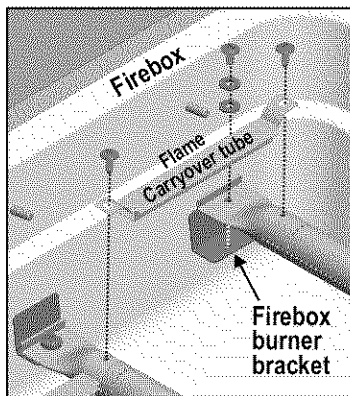
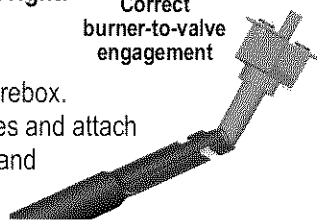

Storing Your Grill

- Clean cooking grates.
- Store in dry location.
- When LP tank is connected to grill, store outdoors in well-ventilated space and out of reach of children.
- Cover grill if stored outdoors.
- Store grill indoors ONLY if LP tank is turned off and disconnected, removed from grill and stored outdoors.
- When removing grill from storage follow "Cleaning Burner Assembly" instructions before starting grill.

Food Safety

Food safety is a very important part of enjoying the outdoor cooking experience. To keep food safe from harmful bacteria, follow these four basic steps:

Clean: Wash hands, utensils, and surfaces with hot soapy water before and after handling raw meat and poultry.

Separate: Separate raw meats and poultry from ready-to-eat foods to avoid cross contamination. Use a clean platter and utensils when removing cooked foods.

Cook: Cook meat and poultry thoroughly to kill bacteria. Use a thermometer to ensure proper internal food temperatures.

Chill: Refrigerate prepared foods and leftovers promptly.

For more information call: USDA Meat and Poultry Hotline at 1-800-535-4555 (In Washington, DC (202) 720-3333, 10:00 am-4:00 pm EST).

How To Tell If Meat Is Grilled Thoroughly

- Meat and poultry cooked on a grill often browns very fast on the outside. Use a meat thermometer to be sure food has reached a safe internal temperature, and cut into food to check for visual signs of doneness.
- Whole poultry should reach 180° F; breasts, 170° F. Juices should run clear and flesh should not be pink.
- Hamburgers made of any ground meat or poultry should reach 160° F, and be brown in the middle with no pink juices. Beef, veal and lamb steaks, roasts and chops can be cooked to 145° F. All cuts of pork should reach 160° F.
- NEVER partially grill meat or poultry and finish cooking later. Cook food completely to destroy harmful bacteria.
- When reheating takeout foods or fully cooked meats like hot dogs, grill to 165° F, or until steaming hot.

Indirect Cooking

Poultry and large cuts of meat cook slowly to perfection on the grill by indirect heat. The heat from selected burners circulates gently throughout the grill, cooking meat or poultry without the touch of a direct flame. This method greatly reduces flare-ups when cooking extra fatty cuts because there is no direct flame to ignite the fats and juices that drip during cooking.

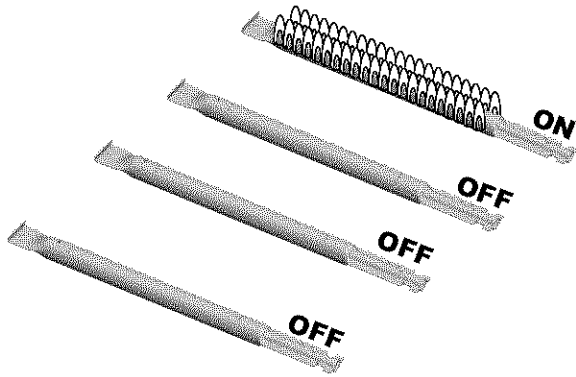

1 Burner Cooking

Cook with direct or indirect heat.
Best for smaller meals or foods.
Consumes less fuel.

Indirect Cooking Instructions

- Always cook with the lid closed.
- Due to weather conditions, cooking times may vary. During cold and windy conditions the temperature setting may need to be increased to insure sufficient cooking temperatures

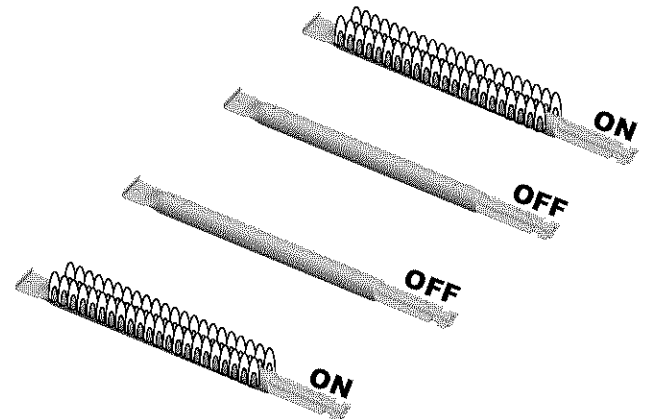

2 Burner Cooking

Great indirect cooking on low.
Produces slow, even heating.
Ideal for slow roasting and baking.

PARTS LIST – Model No. 415.16661800

Key	Qty	Description	Part #	Key	Qty	Description	Part #
1	1	Bottom Shelf	80015716	46	3	Carryover Tube	80015760
2	2	Locking Caster	80000268	47	4	Heat Diffuser	80015759
3	2	Fixed Caster	80004093	48	1	Swing Away Grid	80015517
4	1	Left Cart Side Panel	80015714	49	3	Cooking Grate	80015518
5	1	Right Cart Side Panel	80007203	50	1	Rotisserie Burner, Front Panel	80065115
6	1	Lower Back Panel	80015537	51	1	Rotisserie Burner, Rear Panel	80015734
7	1	Upper Door Brace	80015545	52	1	Electrode Assy, Rotisserie	80015735
8	1	Firebox	80015717	53	1	Rotisserie Burner Tube	80013375
9	1	Left Panel, Firebox	80017202	54	1	Support Bracket for Valve	80065116
10	1	Right Panel, Firebox	80010517	55	1	Rear Cover, Rotisserie Bracket	80016858
11	1	Upper Back Panel	80015542	56	1	Heat Shield, Left, Top Lid Assy	80016409
12	1	Tank Heat Shield	80015543	57	1	Top Lid Assy, Outer	80015738
13	1	Grease Tray	80008970	58	1	Inner Liner, Top Lid	80015739
14	1	Match Holder	80006579	59	1	Temperature Gauge	80016407
15	1	Upper Rear Firebox Panel	80016255	60	1	Bezel, Temperature Gauge	80016408
16	1	Left Side Inner Panel	80010514	61	1	Logo Plate	80015740
17	1	Right Side Inner Panel	80010515	62	1	Top Lid Handle	80015741
18	1	Left Door	80016707	63	3	#8x3/8" Self-tapping Screw	80015743
19	1	Right Door	80016708	64	1	Caster Wrench	80000283
20	2	Door Handle	80015722	65	2	Door Magnet Assy	80008850
21	1	Right Side Shelf	80015548	66	28	1/4" Lock Washer	80015743
22	1	Right Fascia	80010531	67	12	1/4-20x1/2" Screw	80015743
23	4	Hook	80011964	68	4	#8-32 Hex Nut	80015743
24	1	Towel Bar	80016710	69	8	1/4-20x5/8" Screw	80015743
25	1	Left Sideburner Shelf	80015554	70	6	1/4-20x1-3/4" Screw	80015743
26	1	Sideburner Pan	80005654	71	4	#8 Lock Washer	80015743
27	1	Sideburner Fascia	80015725	72	4	#8-32x3/8" Screw	80015743
28	1	Sideburner Lid	80015727	73	4	#10 Lock Washer	80015743
29	1	Sideburner Lid Handle	80015728	74	4	#10-24x3/8" Screw	80015743
30	1	Sideburner Electrode	80015744	75	2	5mm Fibre Washer	80015743
31	1	Sideburner Grate	80003591	76	8	#8-32x3/8" Flat Head Screw	80015743
32	1	Griddle	80003592	77	4	Bracket, F/main Burner Venturi	80016859
33	1	Complete Sideburner	80013400	78	1	Bezel F/side burner	80015731
34	1	Sideburner Cap Clip	80006434		1	Use & Care Guide, English	80011971
35	1	Heat Shield, Right, Top Lid Assy	80016410		1	Use & Care Guide, Spanish	80015742
36	1	Control Panel	80015729		1	Hardware Pack For Top Lid	80009607
37	5	Bezel F/main burner	80017200		1	Hardware Pack	80015743
38	1	Hose/Valve/Regulator Assy	80015732				
39	1	Electric Ignition Module	80007900				
40	1	Battery Cap	80007380				
41	4	Main Burner	80016303				
42	1	Module Cover	80015536				
43	1	Sideburner Wire	80017204				
44	6	Control Knob	80015534				
45	4	Electrode Assy w/Wire, Main Burner	80016705				

PARTS DIAGRAM – Model No. 415.16661800

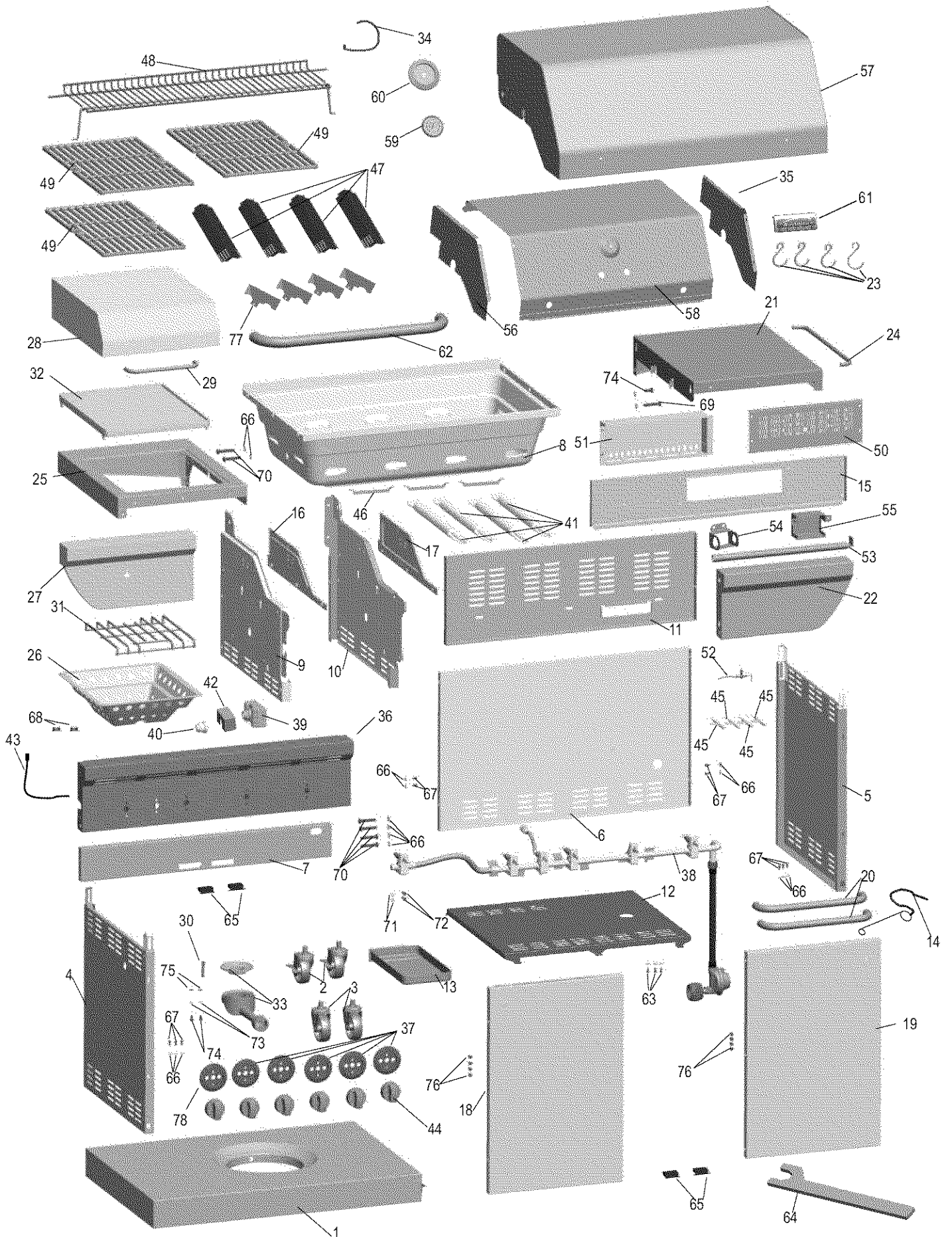

ASSEMBLY – Model No. 415.16661800

1

Bottom Shelf

- Attach the two **Locking Casters** at the **rear** of the bottom shelf.
- Attach the two **Fixed Casters** at the **front**.
- Use the provided **Caster Wrench** to fully tighten casters.

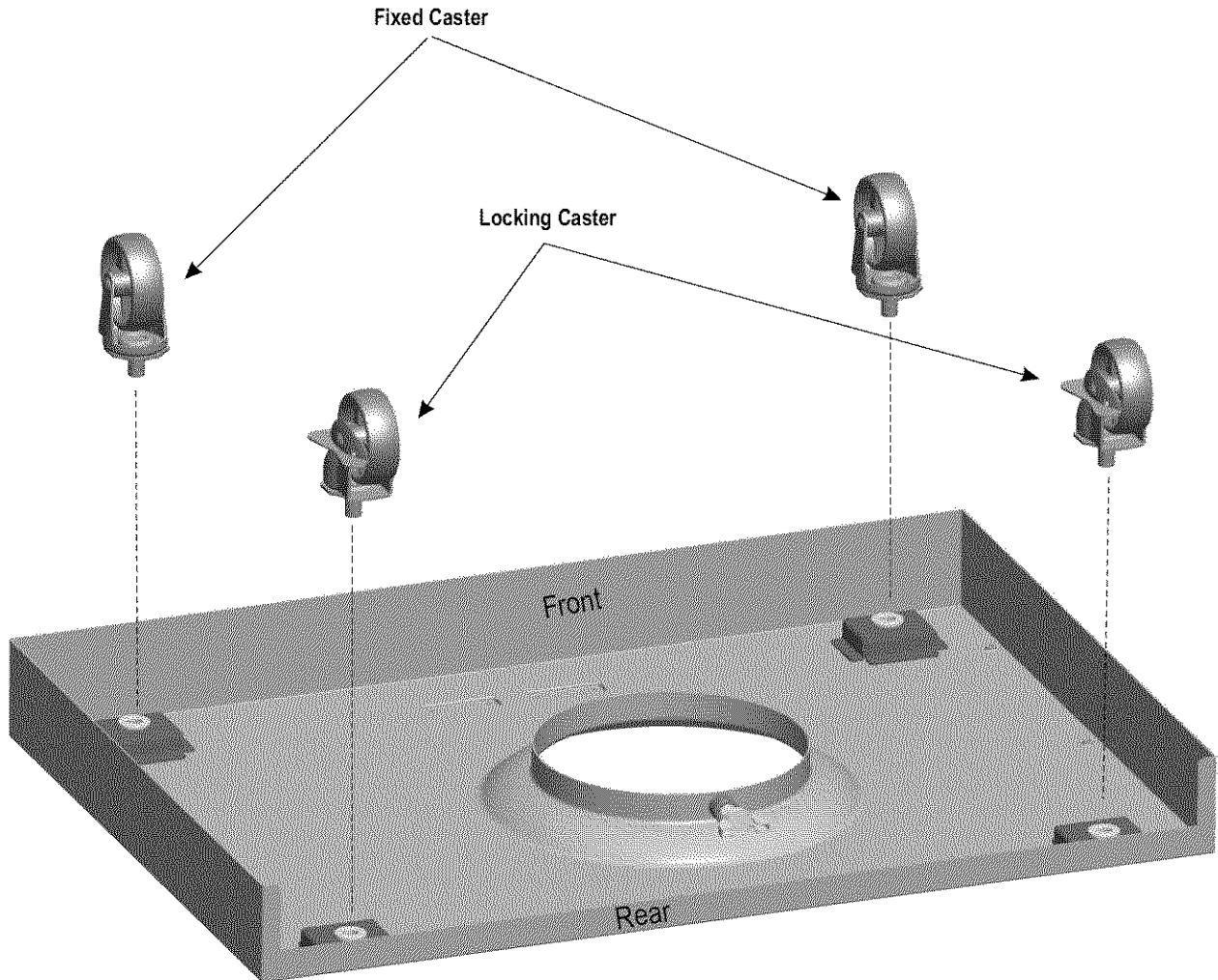
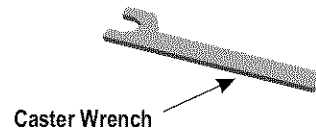

2

Side Cart Panels

- Attach Left & Right Cart Side Panels to Bottom Shelf. **Make sure panel with hole for Electronic Ignition Module is on left side.**
- Use three 1/4"-20x1/2" screw and 1/4" lock washer per panel.
- Remove the large HEX NUT from the Electronic Ignition Module. Place the Module Cover over the Electronic Ignition Module. Insert this assembly into the hole of Left Cart Side Panel, then use the HEX NUT to secure the assembly to the panel (A).

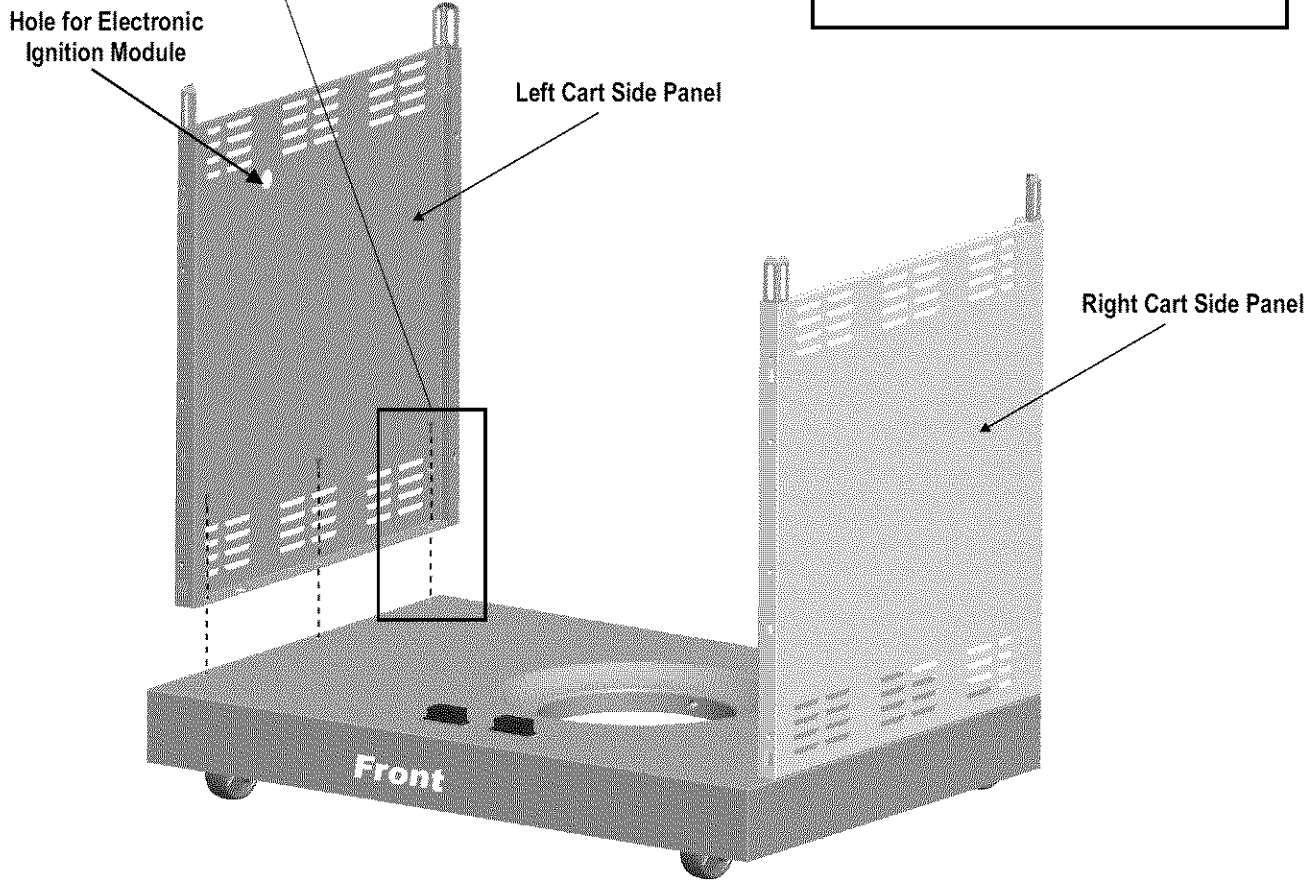
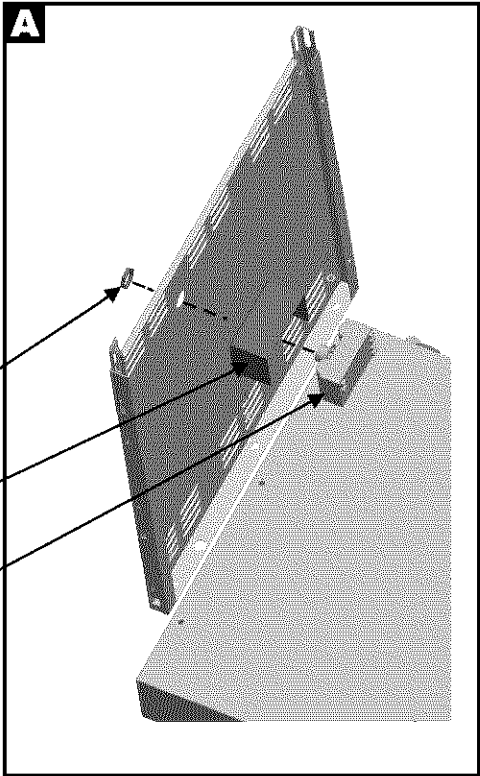
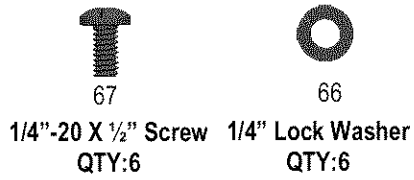
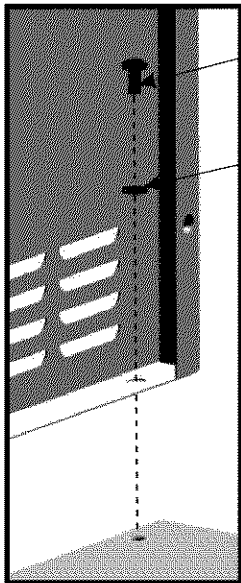

3

Cart Lower Back Panel

- Place Lower Back Panel between side panels at rear of bottom shelf.
- Secure Lower Back Panel to side panels using two 1/4-20x1/2" screw and 1/4" lock washers on each side.
- Secure middle of Lower Back Panel to bottom shelf using one 1/4-20x1/2" screw and 1/4" lock washer.



66

1/4" Lock Washer
QTY:5



67

1/4"-20 X 1/2" Screw
QTY:5

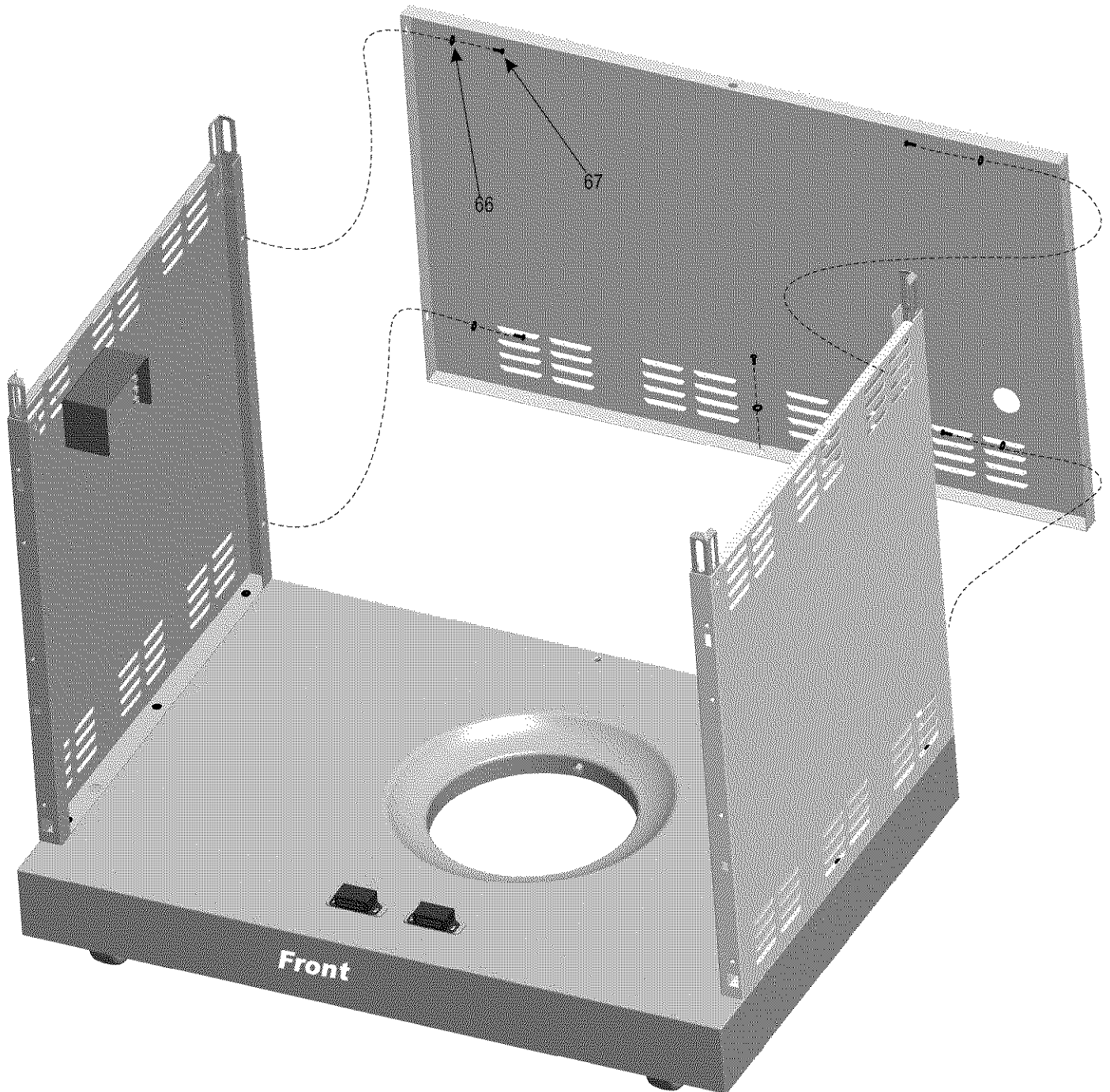

4

Grill Head, Cart Assembly

- This step requires two people to lift and position grill head onto cart.
- Carefully lower the grill head onto the cart, aligning slots at bottom of grill head with posts on cart side panels.
- Grill head must face open side of cart.
- Be sure regulator hose and wires are inside cart.

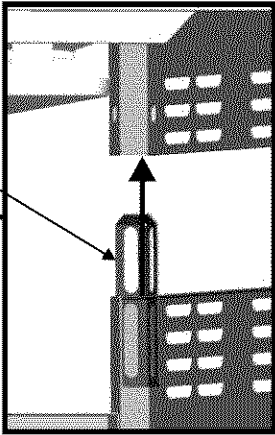
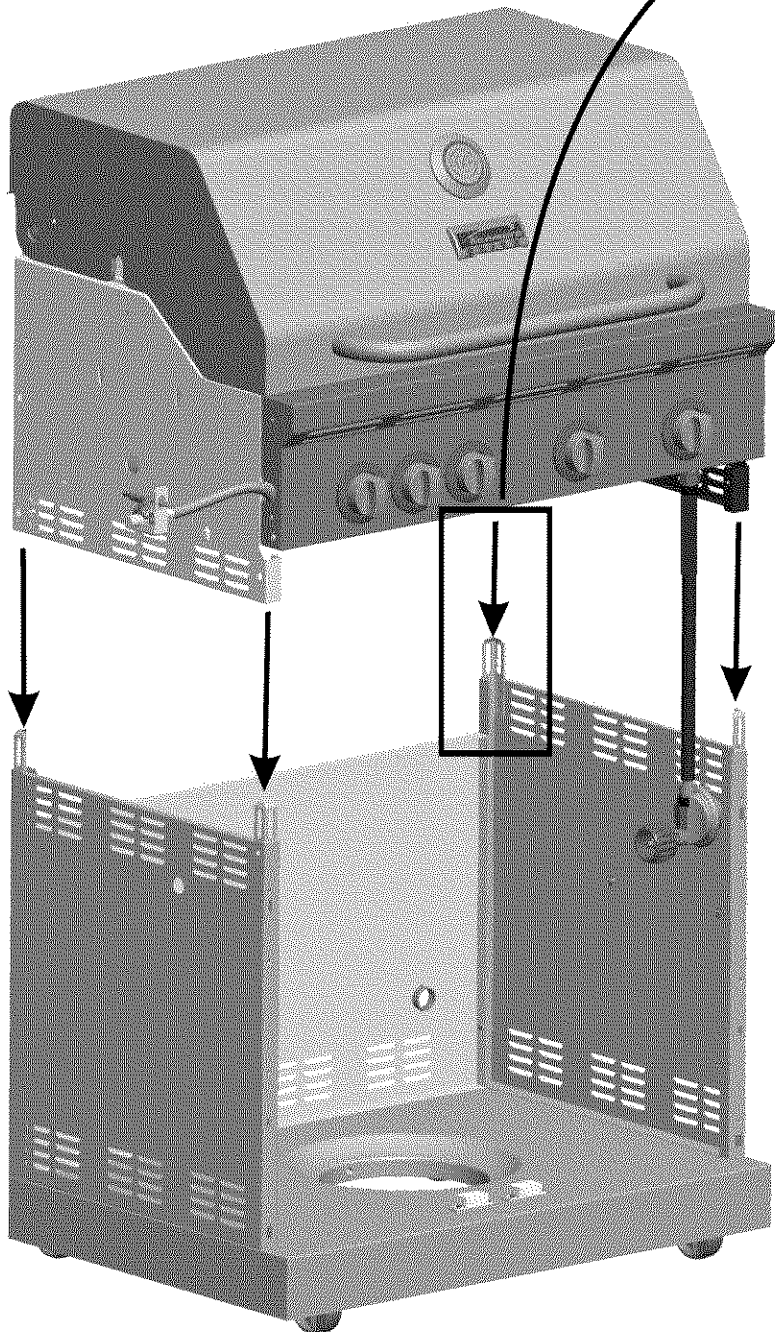

Post

Before assembling the grill head on the cart

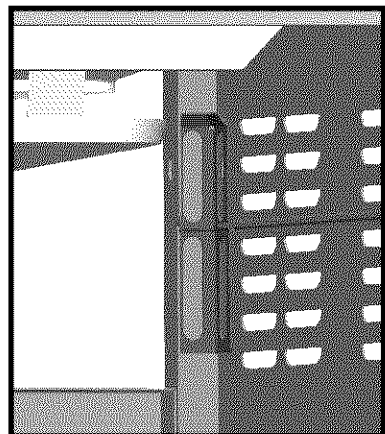

After assembling the grill head on the cart

5 Upper Door Brace

- Insert Upper Door Brace under control panel and between cart sides.
- Secure using two 1/4"-20x1-3/4" screws and 1/4" lock washers on each side.



66
1/4" Lock Washer
QTY:4



70
1/4"-20 X 1-3/4" Screw
QTY:4

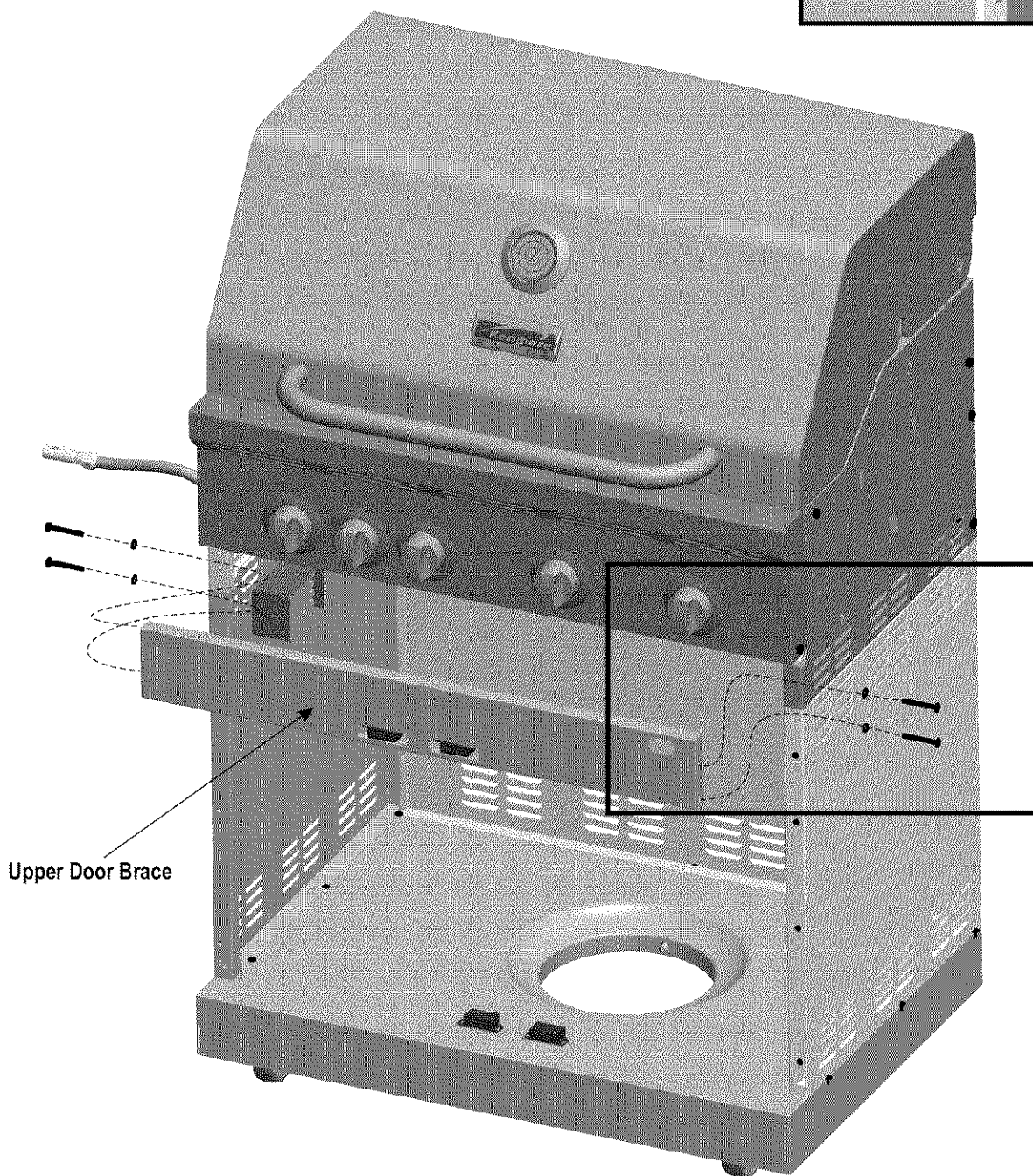
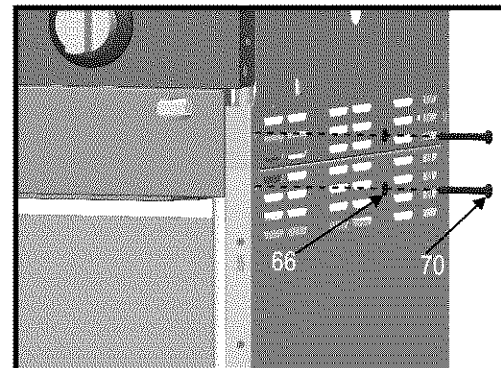

Upper Door Brace

6

Cart Upper Back Panel

- On back of grill, place Cart Upper Back Panel between side panels and above cart lower back panel.
- Secure Cart Upper Back Panel, in lower holes, using one 1/4"-20x1-3/4" screw and 1/4" lock washer on each side (A).
- Secure Cart Upper Back Panel to lower back panel from inside using one 1/4"-20x1/2" screw and 1/4" lock washer in the center hole (B).
- Do not fully tighten screws until side shelf and side burner installation is complete in later steps.

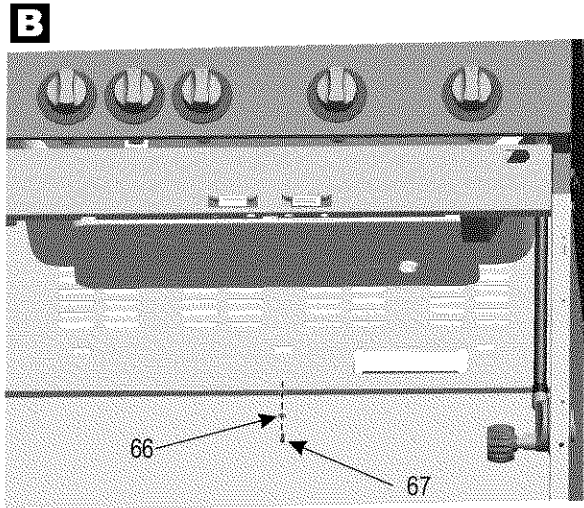
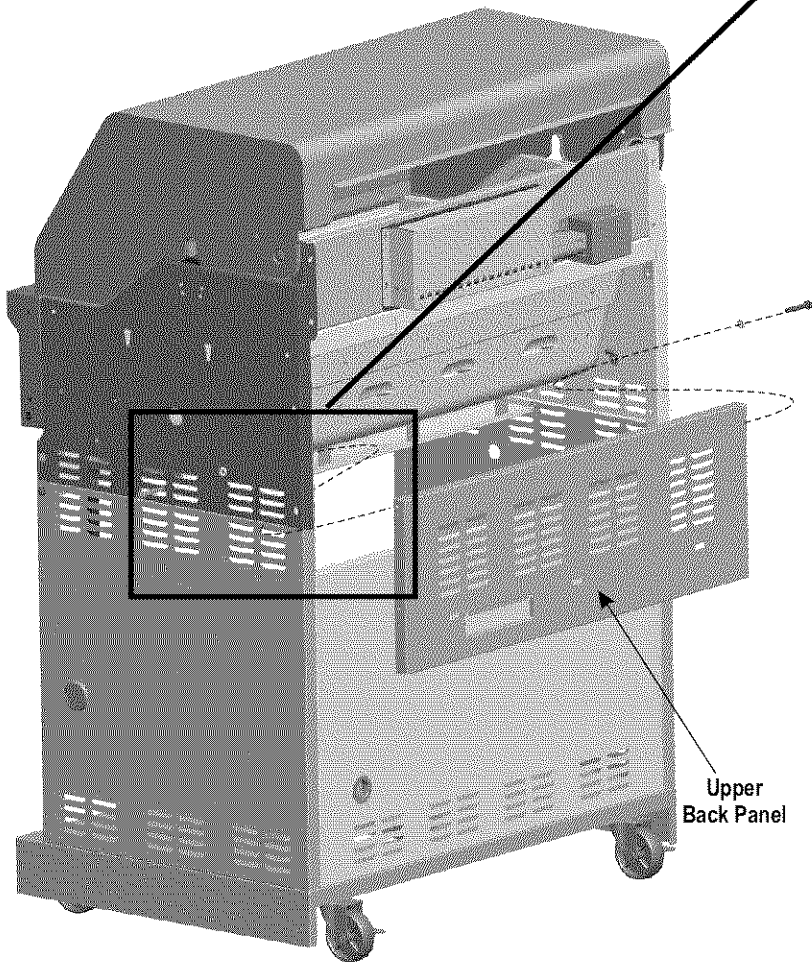
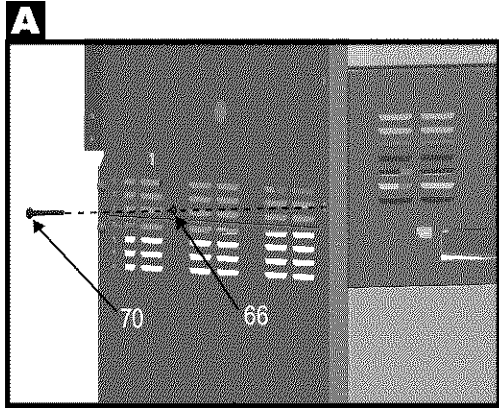

7

Tank Heat Shield Assembly

- Inside of cart (A), insert Rear Shield Tabs of Tank Heat Shield through three cut out slots on upper back panel (B). Make sure grease tray slide is aligned with cut out in upper back panel (C).
- Attach Front Shield Tabs of Tank Heat Shield under Upper Front Brace using three #8x3/8" self-tapping screws (D).
- Install Grease Tray into Grease Tray Slide (E).

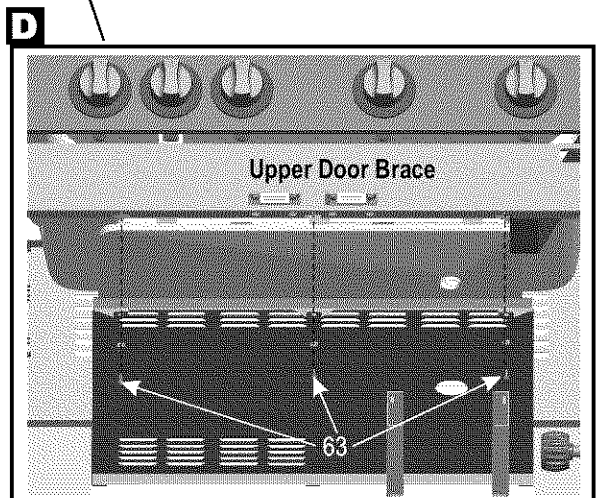
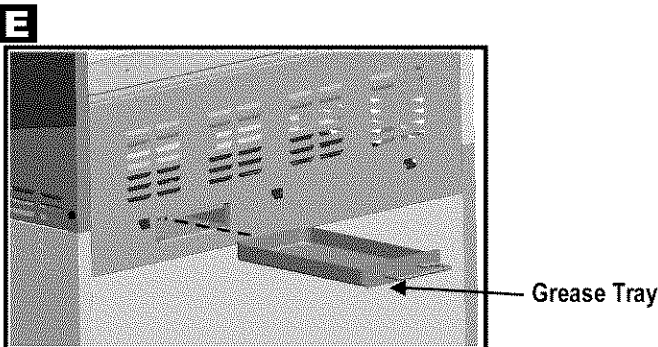
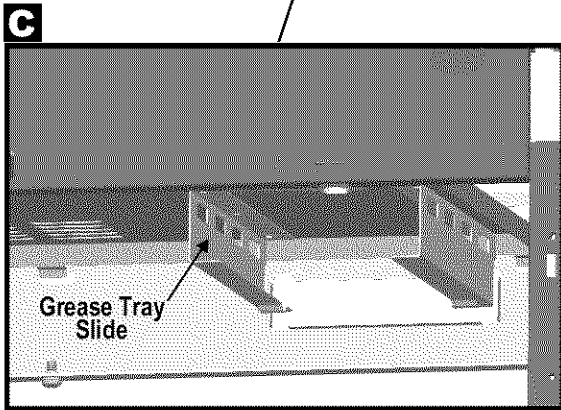
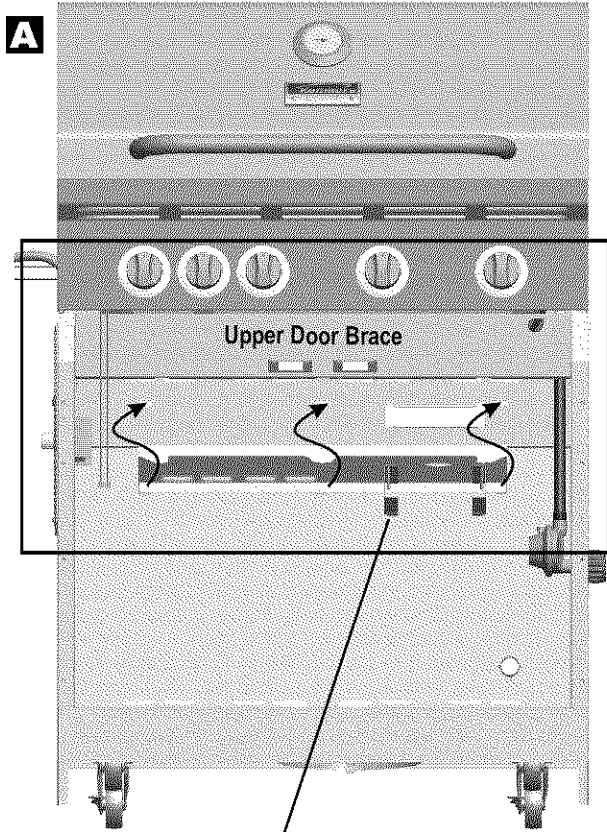
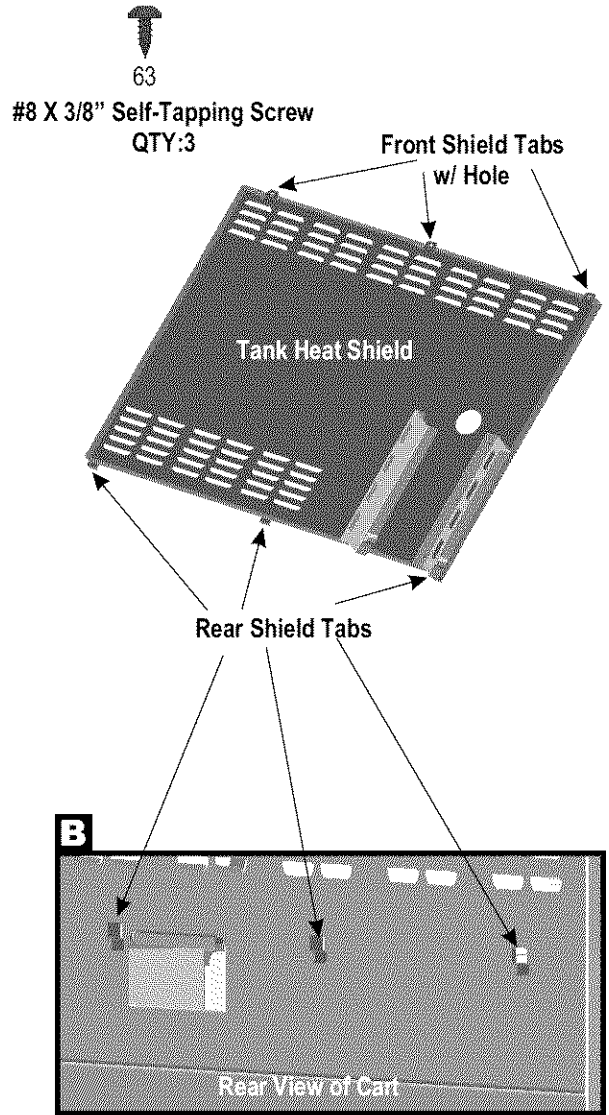

8

Left Door and Right Door

- Attach each door by inserting top hinge tab into slot on front of cart side panel. Then insert bottom hinge tab into bottom slot on front of cart side panel making sure middle hinge tab also inserts into the middle slot.
- Secure each door to cart side panel using four #8-32x3/8 flat head screws.



#8 X 3/8" Flat Head Screw
QTY:8

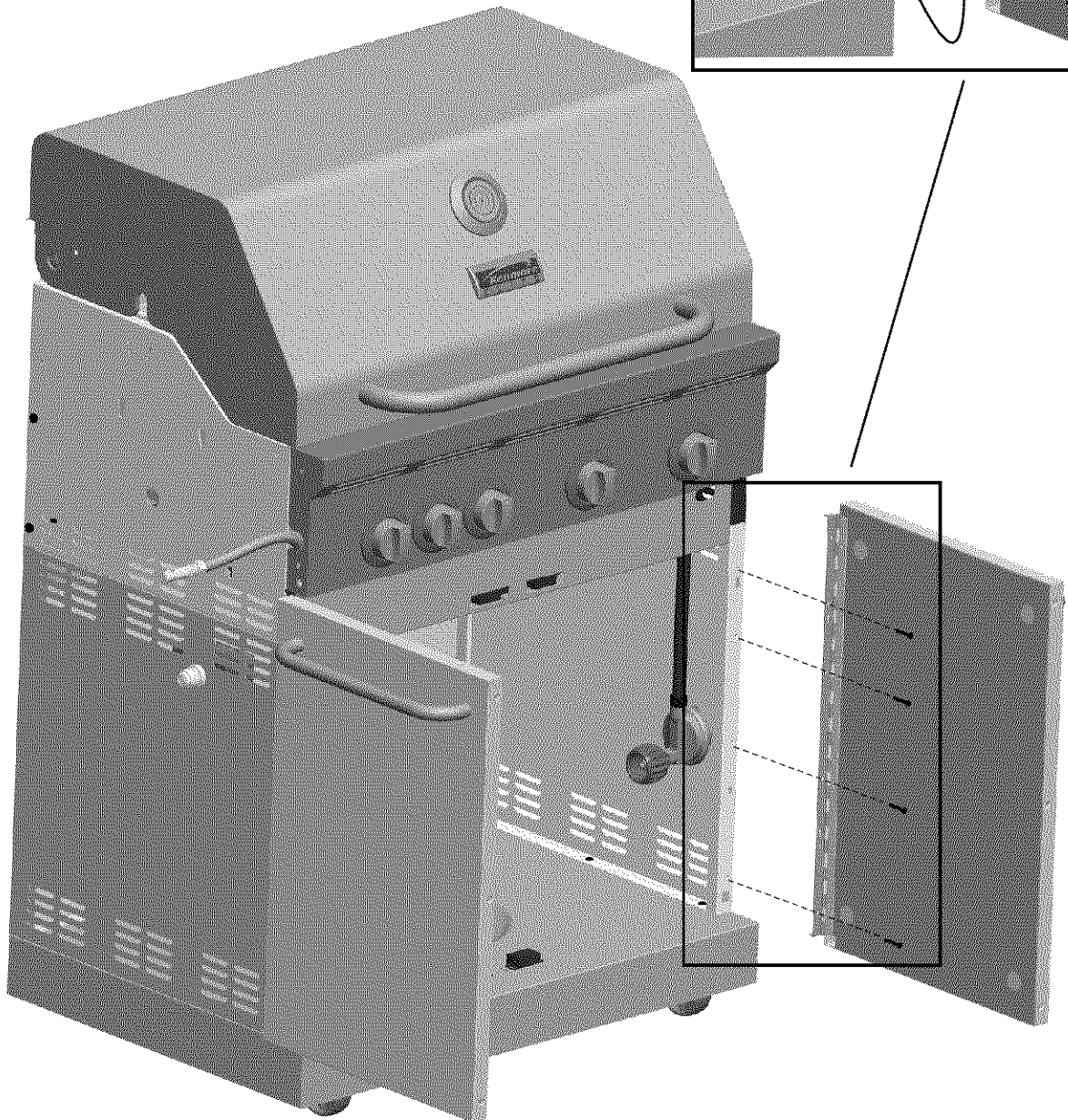
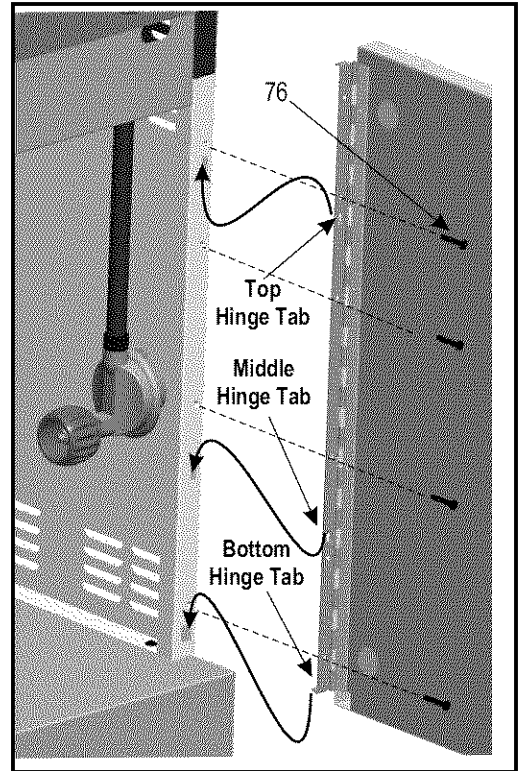

9

Right and Left Shelf Assembly

- Install Hooks onto Towel Bar as shown (A). Hooks should curl inward.
- Attach two #10-24x1/2" screws and #10 lock washers through Right Side Shelf holes into Towel Bar (A).
- Attach two 1/4-20x5/8" screws and 1/4" lock washers to the side panel (B). Tighten only partially, approximately 1/4 of screw length, so that shelf brackets will slide between cart and washers.
- Insert side shelf over screws and washers through bracket **See views B, C and D.** Make sure the tabs in the middle of side shelf are inserted into the side panel cut-outs (C).
- Attach one 1/4-20x1-3/4" screw and 1/4" lock washer at the rear shelf support bracket (D).
- Attach two 1/4-20x5/8" screw and 1/4" lock washer at the front shelf support bracket (E). Now fully tighten screws at the tops of the shelf support brackets (B).
- For left sideburner shelf, repeat above steps for B, C, D, & E.
- Fully tighten rear panel screws now.

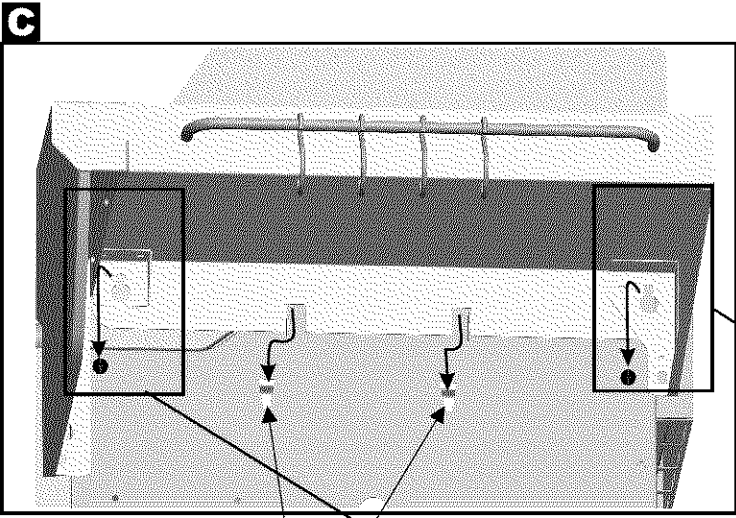
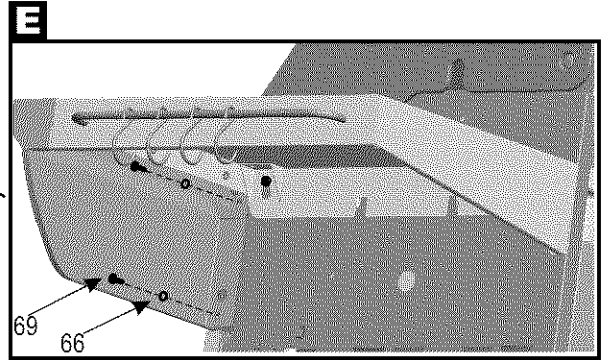
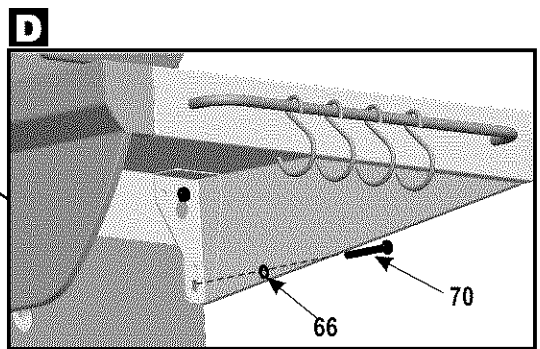
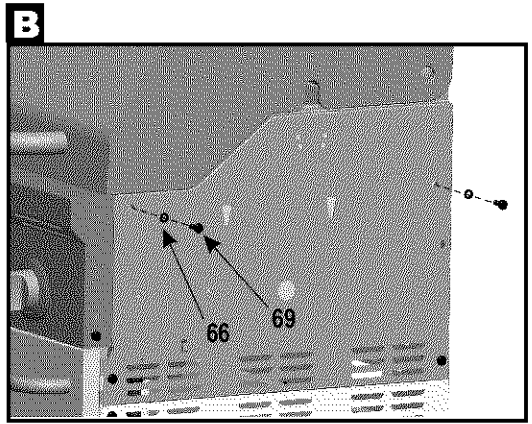
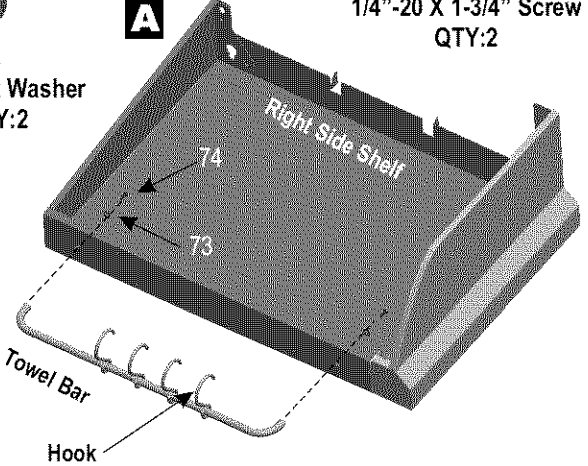
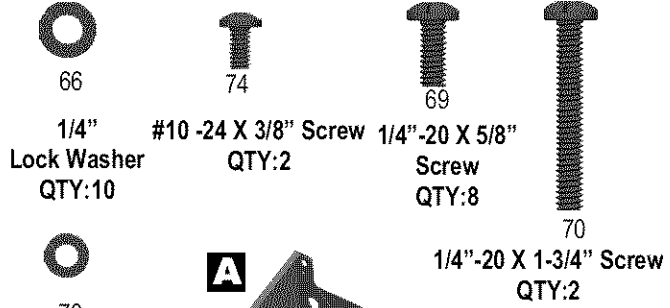

Cut-outs in Side Panel

10

Sideburner Control Knob Assembly

- First, remove the two #8-32x3/8" screws and #8 lock washers from the sideburner valve bracket (A).
- Position sideburner valve bracket beneath side burner shelf fascia so that valve stem comes through larger center hole in fascia (B).
- Attach Bezel to Fascia using screws that were removed from bracket (B).
- Press Control Knob onto valve stem (B).

71
#8 Lock Washer
QTY:2

72
#8 X 3/8" Screw
QTY:2

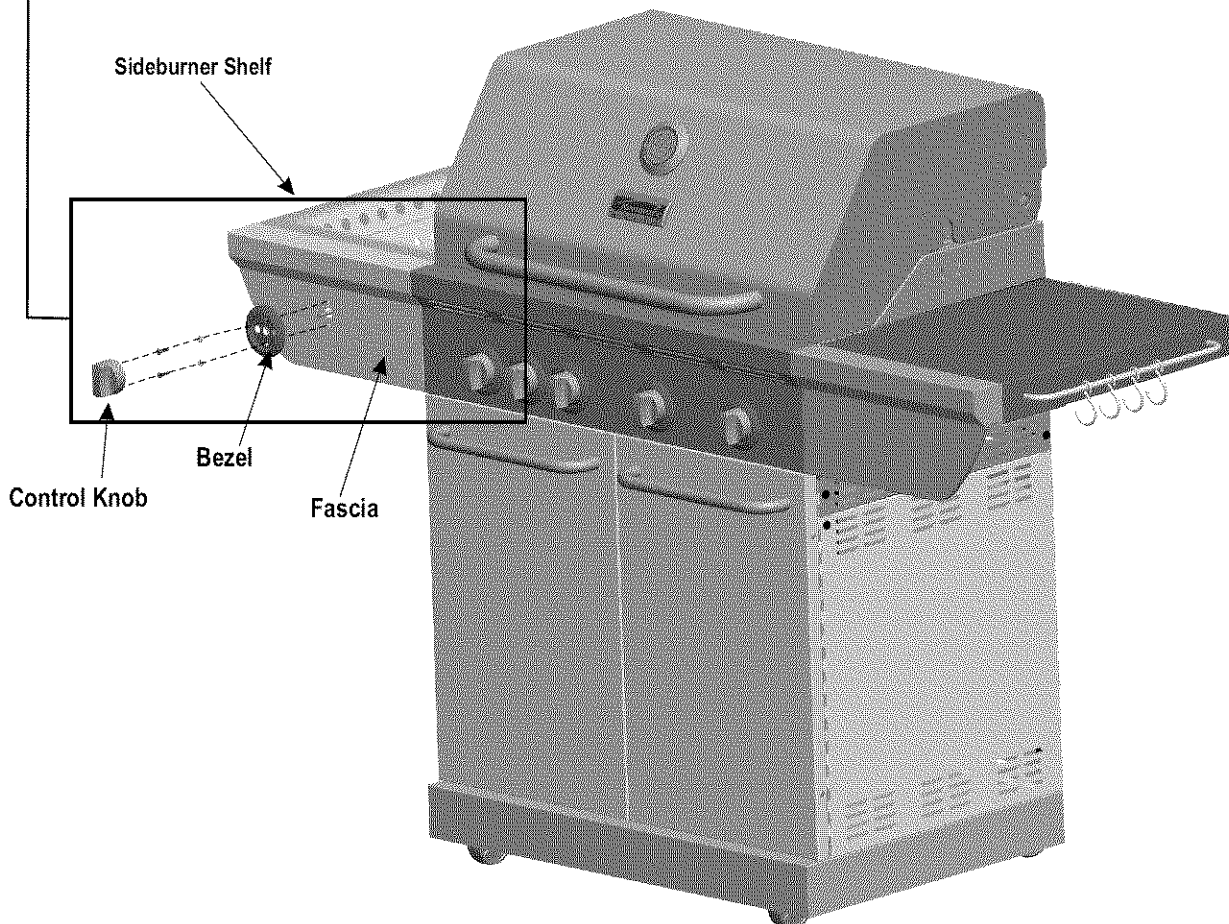
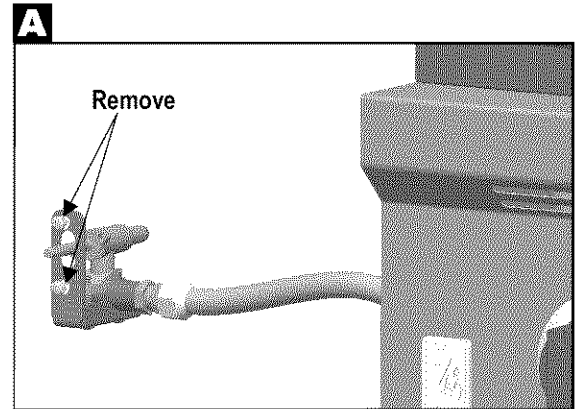
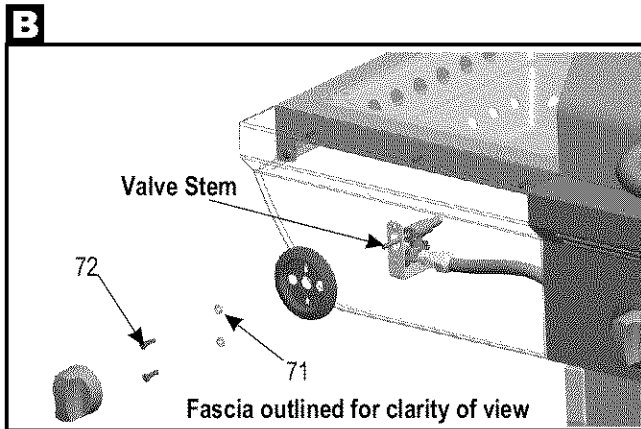
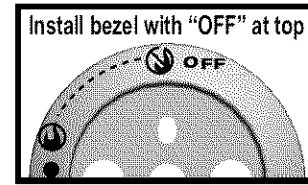

11

Sideburner Assembly

- Insert front of Sideburner through cut-out in bottom of left shelf shown (A). Center stud on bottom rear of Sideburner fits into center hole in burner pan of left shelf.
- Make sure Sideburner tube aligns correctly onto sideburner valve underneath left shelf (B).
- Secure Sideburner to pan using two #10-24x3/8" screws and 5mm fiber washers and #10 lock washers (C).
- Attach Sideburner Igniter Wire from Electronic Ignition Module to Electrode Tip underneath left shelf shown (D).



73



74



75

#10 Lock Washer
QTY:2

#10 -24 X 3/8" Screw
QTY:2

5mm Fiber Washer
QTY:2

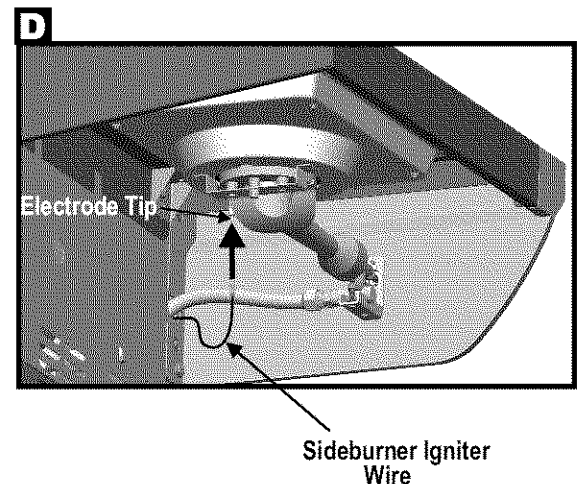
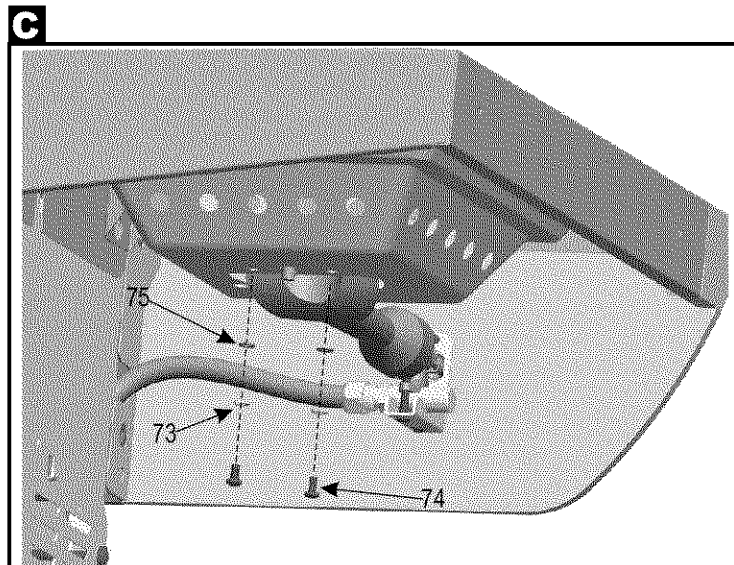
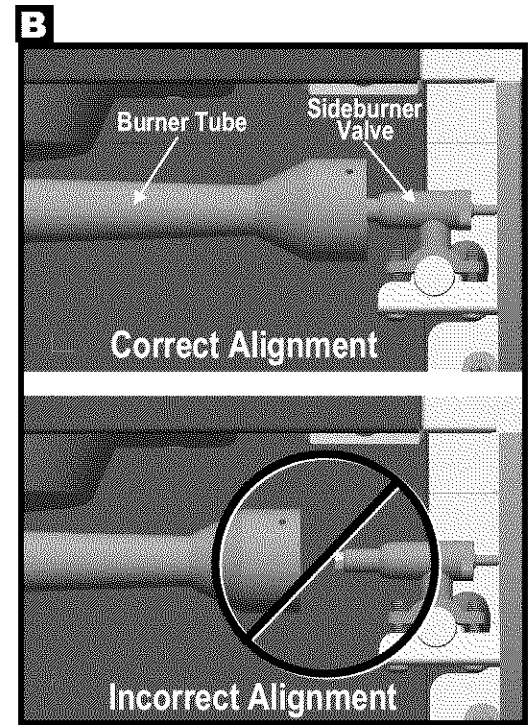
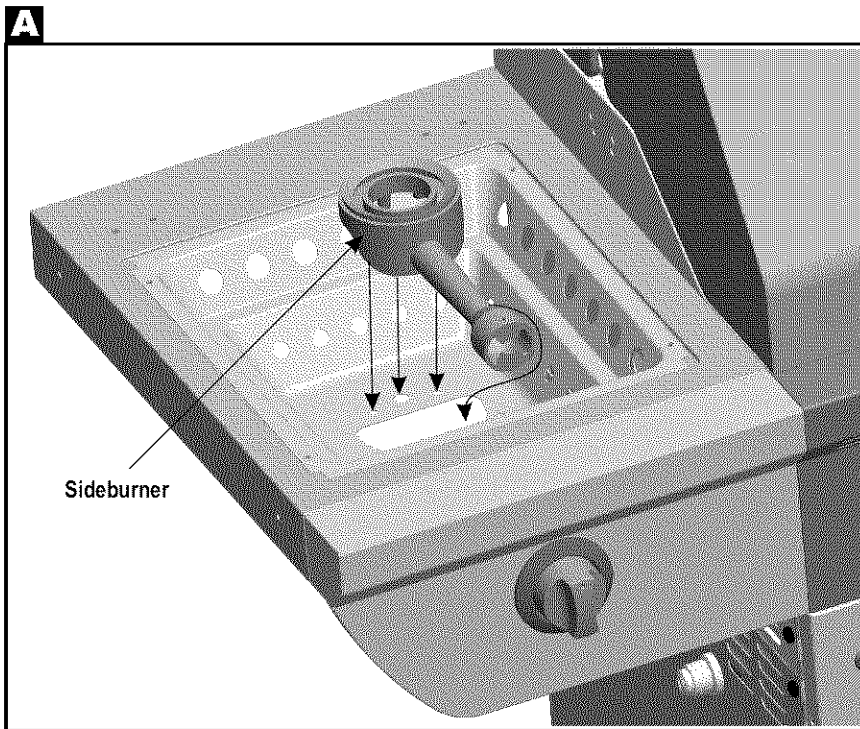

12

Sideburner Lid, Sideburner Cap and Clip, Sideburner Grate, Giddle

- Secure Sideburner Lid using four #8-32x3/8" screws, #8 lock washers, and #8 flange nuts to shelf (A).
- Place Burner Cap onto sideburner and attach Sideburner Cap Clip (C).
- Place Sideburner Grate onto sideburner shelf.
- Place Griddle onto sideburner shelf.



#8 Lock Washer
QTY:4



#8 X 3/8" Screw
QTY:4

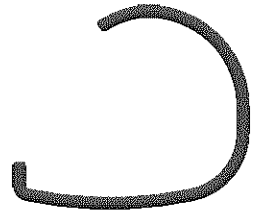

34

Sideburner Cap Clip
QTY:1



#8 Hex Nut
QTY:4

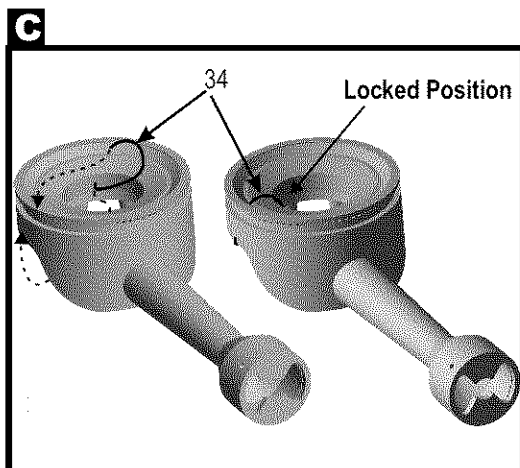
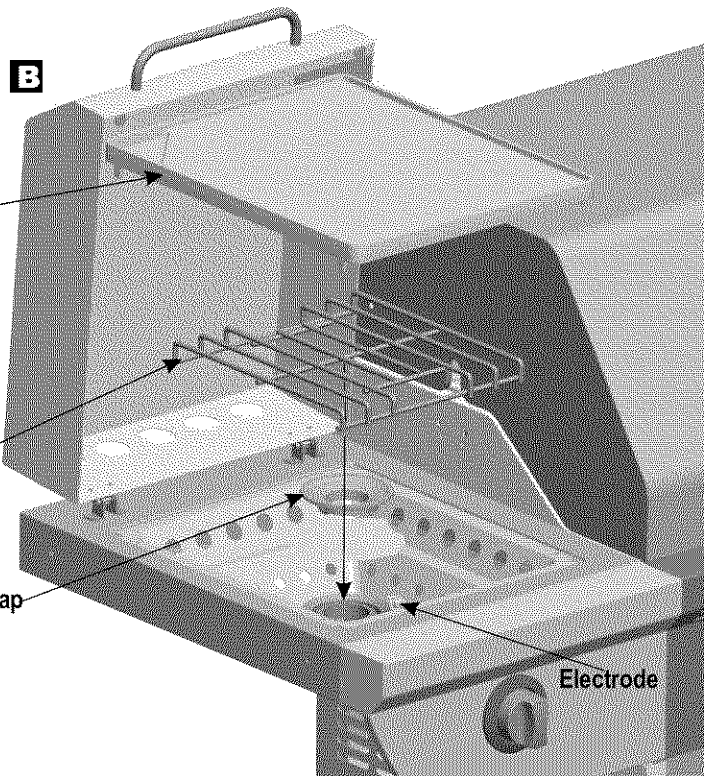
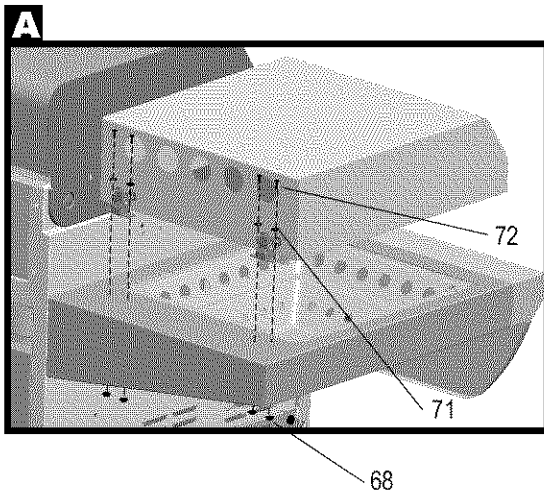

13

Heat Diffusers

- Install each Heat Diffuser by inserting one end with perforated hole (stamping with "FRONT") into slots at front of firebox bracket and resting opposite end (Stamping with "REAR") on pin located at back of firebox.

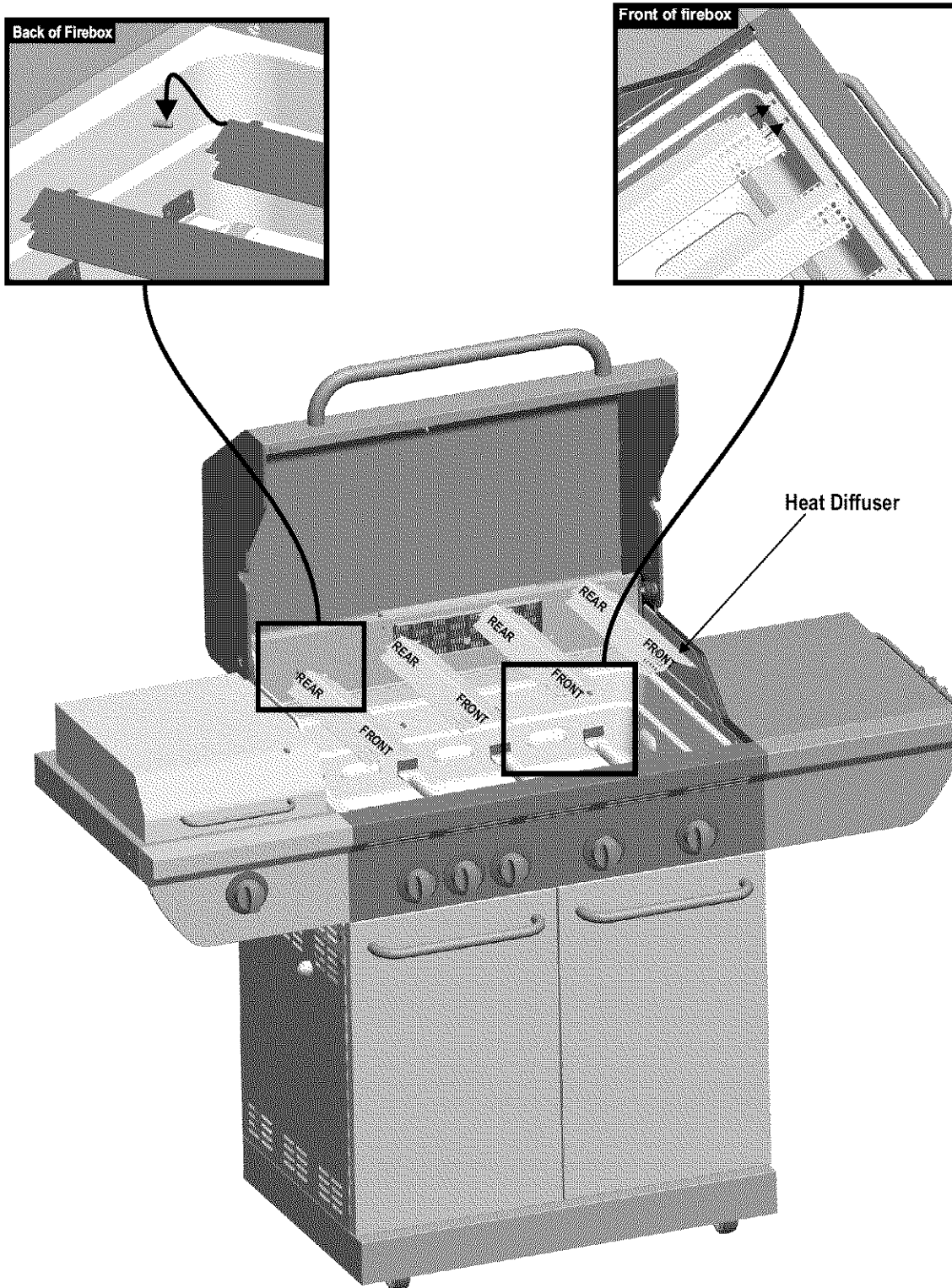

14 Cooking Grates and Swing Away Grid

- Place Cooking Grates onto the firebox as shown.
- To install the Swing Away Grid, insert the end of the stationary leg into the hole on the side of the lid and the end of the rotating leg into the hole on the side of the firebox on the same side. Then insert the opposite ends of the legs into the corresponding holes on the other side of the lid and firebox. **NOTE: Wall at the back of the grid should be in the up position.**

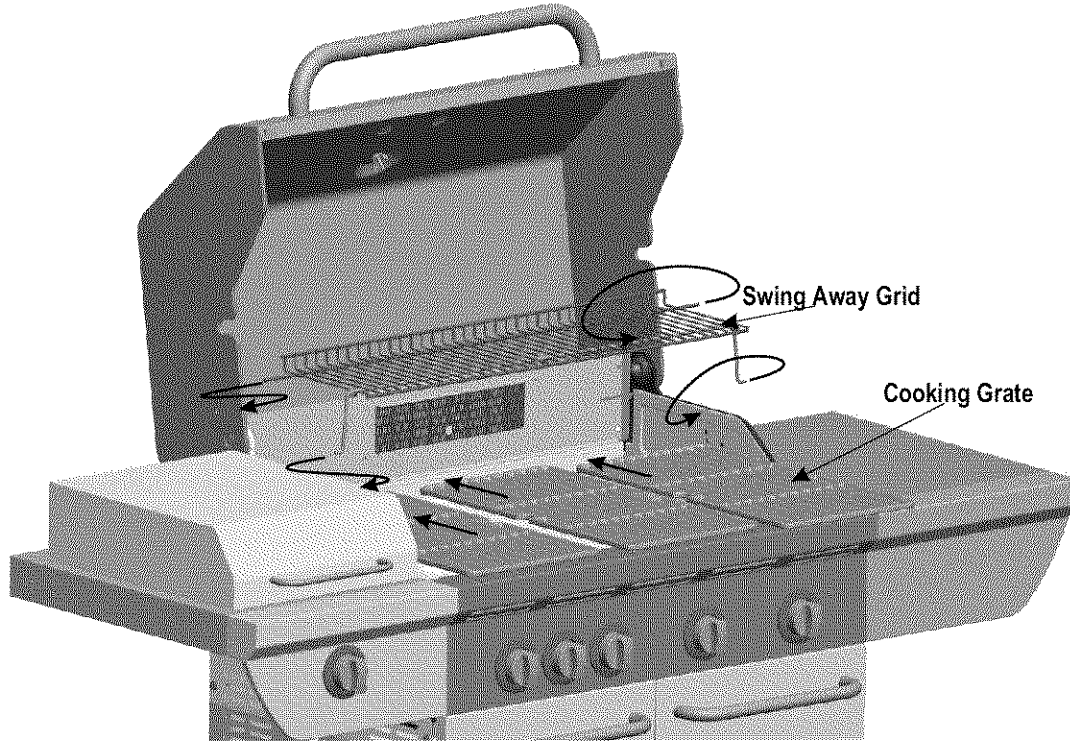

15 Wiring Connections and Battery

- Connect each of the wires from the main burner electrodes, rotisserie burner electrode, and sideburner electrode into the back of the Electronic Ignition Module. Total (6) connections.
- Connect the two wires from the switch wiring harness into the back of the Electronic Ignition Module. Total (2) connections. **NOTE: Switch terminals are larger than electrode terminals and should only be installed in location shown as C,D.(A)**
- Place AA battery into Electronic Ignition Module with the negative (-) side facing outward. Screw Battery Cap onto Electronic Ignition module. **(B)**

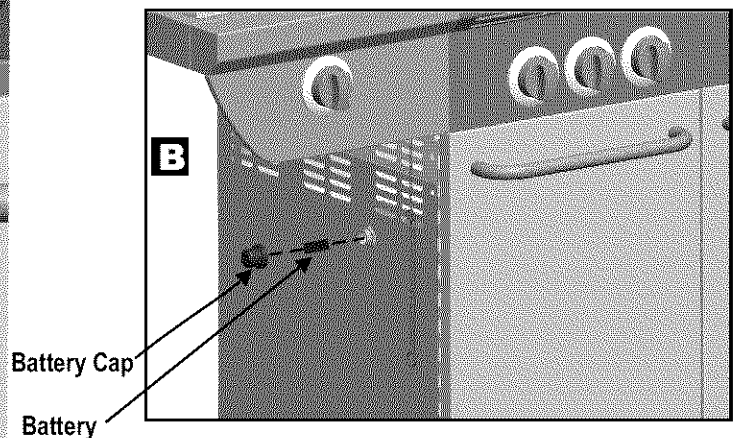
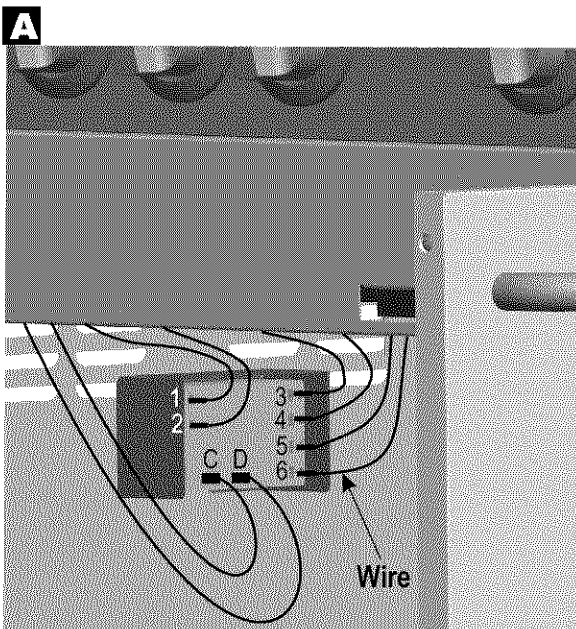

16

LP Tank

- LP TANK IS SOLD SEPARATELY.** Fill and leak check the tank before attaching to grill and regulator (see Use & Care section).
- Once tank has been filled and leak checked, place tank into cut-out in bottom shelf. **Make sure tank valve is facing front of grill.**
- Secure tank with tank screw under bottom shelf. **See Use & Care section of this manual to perform the "Burner Flame Check" and for important safety instructions before using.**

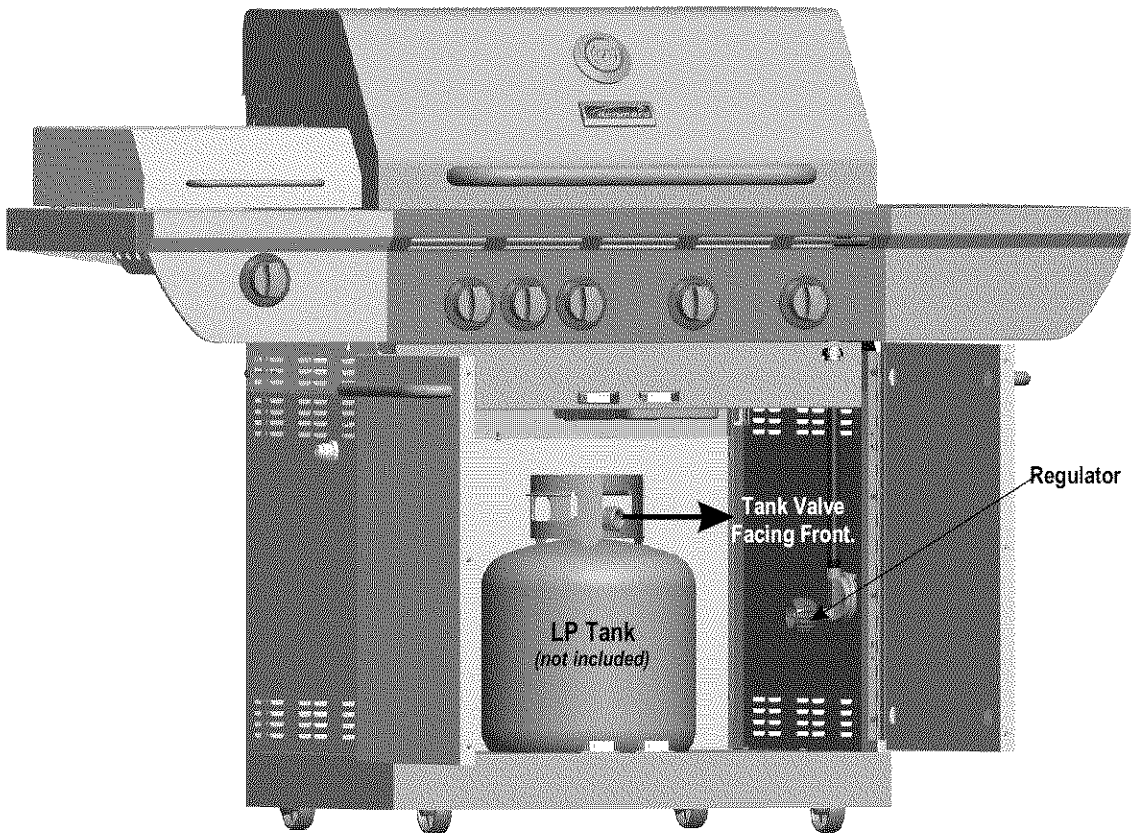



CAUTION



LP Tank valve must face to front of cart once tank is attached. Failure to install tank correctly may allow gas hose to be damaged in operation, resulting in the risk of fire.

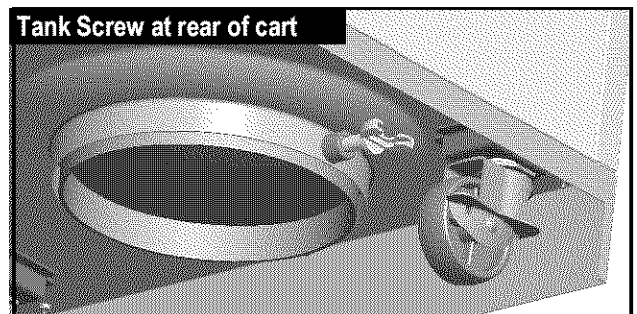

Always keep LP tank in upright position during use, transport, and storage.

Troubleshooting

EMERGENCIES: If a gas leak cannot be stopped, or a fire occurs due to gas leakage, call the fire department.



Emergencies	Possible Cause	Prevention/Solution
Gas leaking from cracked/cut/burned hose.	<ul style="list-style-type: none"> Damaged hose. 	<ul style="list-style-type: none"> Turn off gas at LP tank. If hose is cut or cracked, replace valve/hose/regulator. See LP Tank Leak Test and Connecting Regulator To The LP Tank.
Gas leaking from LP tank.	<ul style="list-style-type: none"> Mechanical failure due to rusting or mishandling. 	<ul style="list-style-type: none"> Turn off LP tank valve.
Gas leaking from LP tank valve.	<ul style="list-style-type: none"> Failure of tank valve from mishandling or mechanical failure. 	<ul style="list-style-type: none"> Turn off LP tank valve. Return LP tank to gas supplier.
Gas leaking between LP tank and regulator connection.	<ul style="list-style-type: none"> Improper installation, connection not tight, failure of rubber seal. 	<ul style="list-style-type: none"> Turn off LP tank valve. Remove regulator from tank and visually inspect rubber seal for damage. See LP Tank Leak Test and Connecting Regulator To The LP Tank.
Fire coming through control panel.	<ul style="list-style-type: none"> Fire in burner tube section of burner due to partial blockage. 	<ul style="list-style-type: none"> Turn off control knobs and LP tank valve. Leave lid open to allow flames to die down. After fire is out and grill is cold, remove burner and inspect for spider nests or rust. See Natural Hazard and Cleaning The Burner Assembly pages.
Troubleshooting: Problem	Possible Cause	Prevention/Solution
Grease fire or continuous excessive flames above cooking surface.	<ul style="list-style-type: none"> Too much grease buildup in burner area. 	<ul style="list-style-type: none"> Turn off LP tank valve. Leave lid open to allow flames to die down. After cooling, clean food particles and excess grease from inside firebox area, grease cup/pan/tray, and other surfaces.
Burner(s) will not light using ignitor.	<p>GAS ISSUES:</p> <ul style="list-style-type: none"> Burner not engaged with control valve. Obstruction in burner. No gas flow. Vapor lock at coupling nut to LP tank. Coupling nut and LP tank valve not fully connected. 	<ul style="list-style-type: none"> Make sure valves are positioned inside of burner tubes. Ensure burner tubes are not obstructed with spider webs or other matter. See cleaning section of Use and Care. Make sure LP tank is not empty. If LP tank is not empty, refer to "Sudden drop in gas flow." Turn off knobs and disconnect coupling nut from LP tank. Reconnect and retry. Turn the coupling nut approximately one-half to three-quarters additional turn until solid stop. Tighten by hand only - do not use tools.
	<p>ELECTRICAL ISSUES:</p> <ul style="list-style-type: none"> Electrode cracked or broken; "sparks at crack." Electrode tip not in proper position. Wire and/or electrode covered with cooking residue. Wires are loose or disconnected. Wires are shorting (sparking) between ignitor and electrode. 	<ul style="list-style-type: none"> Replace electrode. Tip of electrode should be pointing toward port hole in burner. The distance should be 1/8" to 3/16". Adjust if necessary. Clean wire and/or electrode with rubbing alcohol and clean swab. Reconnect wires or replace electrode/wire assembly. Replace ignitor wire.

Continued on next page.

Troubleshooting (*continued*)

Problem	Possible Cause	Prevention/Solution
Burner(s) will not light using ignitor.	<ul style="list-style-type: none"> Faulty electronic ignition circuit. Sparking somewhere other than between burner and electrode. 	<ul style="list-style-type: none"> See Troubleshooting Integrated Electronic Ignition section. Inspect wire insulation and proper connections. Replace wires if insulation is broken.
Burner(s) will not match light.	<ul style="list-style-type: none"> See "GAS ISSUES:" on previous page. Improper method of match-lighting. 	<ul style="list-style-type: none"> See "Match-Lighting" section of Use and Care.
Sudden drop in gas flow or low flame.	<ul style="list-style-type: none"> Out of gas. Excess flow valve tripped. Vapor lock at coupling nut/LP tank connection. 	<ul style="list-style-type: none"> Check for gas in LP tank. Turn off knobs, wait 30 seconds and light grill. If flames are still low, turn off knobs and LP tank valve. Disconnect regulator. Reconnect regulator and leak-test. Turn on LP tank valve, wait 30 seconds and then light grill. Turn off knobs and LP tank valve. Disconnect coupling nut from tank. Reconnect and retry.
Flames blow out.	<ul style="list-style-type: none"> High or gusting winds. Low on LP gas. Excess flow valve tripped. 	<ul style="list-style-type: none"> Turn front of grill to face wind or increase flame height. Refill LP tank. Refer to "Sudden drop in gas flow" above.
Flare-up.	<ul style="list-style-type: none"> Grease buildup. Excessive fat in meat. Excessive cooking temperature. 	<ul style="list-style-type: none"> Clean burners and inside of grill/firebox. Trim fat from meat before grilling. Adjust (lower) temperature accordingly.
Persistent grease fire.	<ul style="list-style-type: none"> Grease trapped by food buildup around burner system. 	<ul style="list-style-type: none"> Turn knobs to OFF. Turn gas off at LP tank. Leave lid in position and let fire burn out. After grill cools, remove and clean all parts.
Flashback... (fire in burner tube(s)).	<ul style="list-style-type: none"> Burner and/or burner tubes are blocked. 	<ul style="list-style-type: none"> Turn knobs to OFF. Clean burner and/or burner tubes. See burner cleaning section of Use and Care manual.
Unable to fill LP tank.	<ul style="list-style-type: none"> Some dealers have older fill nozzles with worn threads. 	<ul style="list-style-type: none"> The worn nozzles don't have enough "bite" to engage the valve. Try a second LP dealer.
One burner does not light from other burner(s).	<ul style="list-style-type: none"> Grease buildup or food particles in end(s) of carryover tube(s). 	<ul style="list-style-type: none"> Clean carry-over tube(s) with wire brush.

Troubleshooting - Integrated Electronic Ignition

Problem (Ignition)	Possible Cause	Check Procedure	Prevention/Solution
<p>SECTION I No sparks appear at any electrodes when burner control knobs are turned to ; no noise can be heard from spark module.</p>	<ul style="list-style-type: none"> • Battery not installed properly. • Dead battery. • Battery cap not installed properly. • Faulty spark module. 	<ul style="list-style-type: none"> • Check battery orientation. • Has battery been used previously? • Check to ensure battery cap is fully engaged. • If no sparks are generated with new battery and good wire connections, module is faulty. 	<ul style="list-style-type: none"> • Install battery (make sure that “+” and “-” connectors are oriented correctly, with “+” end up and “-” end down.) • Replace battery with new AA-size alkaline battery. • Remove battery cap and reinstall, making sure it can be fully engaged. • Replace spark module assembly.
<p>SECTION II No sparks appear at any electrodes when burner control knobs are turned to ; noise can be heard from spark module.</p>	<ul style="list-style-type: none"> • Output lead connections not connected. • Electrode tip not in proper position. 	<ul style="list-style-type: none"> • Are output connections on and tight? • Are the electrode tips pointing in the right direction? Is the gap too big? 	<ul style="list-style-type: none"> • Remove and reconnect all output connections at module and electrodes. <p>Main Burners:</p> <ul style="list-style-type: none"> • Tip of electrode should be pointing toward port hole in burner. The distance should be 1/8” to 3/16”. <p>Adjust if necessary.</p> <p>Sideburner:</p> <ul style="list-style-type: none"> • Tip of electrode should be pointing toward gas port opening on burner. The distance should be 1/8” to 3/16”. Adjust if necessary.
<p>SECTION III Sparks are present but not at all electrodes and/or not at full strength</p>	<ul style="list-style-type: none"> • Output lead connections not connected. • Arcing to grill away from burner(s). • Weak battery. • Electrodes are wet. • Electrodes cracked or broken “sparks at crack”. 	<ul style="list-style-type: none"> • Are output connections on and tight? • If possible, observe grill in dark location. Operate ignition system and look for arcing between output wires and grill frame. • All sparks present but weak or at slow rate. • Has moisture accumulated on electrode and/or in burner ports? • Inspect electrodes for cracks. 	<ul style="list-style-type: none"> • Remove and reconnect all output connections at module and electrodes. • If sparks are observed other than from burner(s), wire insulation may be damaged. Replace wires. • Replace battery with a new AA-size alkaline battery. • Use paper towel to remove moisture. • Replace cracked or broken electrodes.

Get it fixed, at your home or ours!

Your Home

For repair—in **your home**—of **all** major brand appliances, lawn and garden equipment, or heating and cooling systems, **no matter who made it, no matter who sold it!**

For the replacement parts, accessories and owner's manuals that you need to do-it-yourself.

For Sears professional installation of home appliances and items like garage door openers and water heaters.

1-800-4-MY-HOME® (1-800-469-4663)

Call anytime, day or night (U.S.A. and Canada)

www.sears.com www.sears.ca

For expert home solutions advice: www.managemyhome.com

Our Home

For repair of carry-in items like vacuums, lawn equipment, and electronics, call or go on-line for the location of your nearest **Sears Parts & Repair Service Center**

1-800-488-1222 (U.S.A) **1-800-469-4663** (Canada)

Call anytime, day or night

www.sears.com www.sears.ca

To purchase a protection agreement on a product serviced by Sears:

1-800-827-6655 (U.S.A.)

1-800-361-6665 (Canada)

Para pedir servicio de reparación a domicilio, y para ordenar piezas:

1-888-SU-HOGAR®

(1-888-784-6427)

Au Canada pour service en français:

1-800-LE-FOYER^{MC}

(1-800-533-6937)

www.sears.ca



® Registered Trademark / ™ Trademark / ™ Service Mark of Sears Brands, LLC

® Marca Registrada / ™ Marca de Fábrica / ™ Marca de Servicio de Sears Brands, LLC

^{MC} Marque de commerce / ^{MD} Marque déposée de Sears Brands, LLC

© Sears Brands, LLC