

# PRO-FORM L18

Model No. 831.298072

Serial No. \_\_\_\_\_

Find the serial number in the location shown below. Write the serial number in the space above for reference.

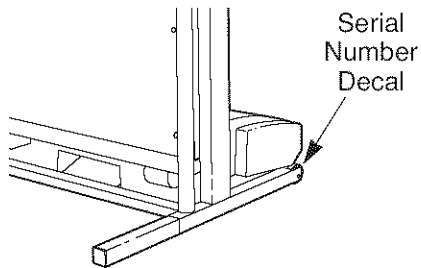

EXERCISE  
EQUIPMENT

QUESTIONS

HELPLINE!

1-800-736-6879

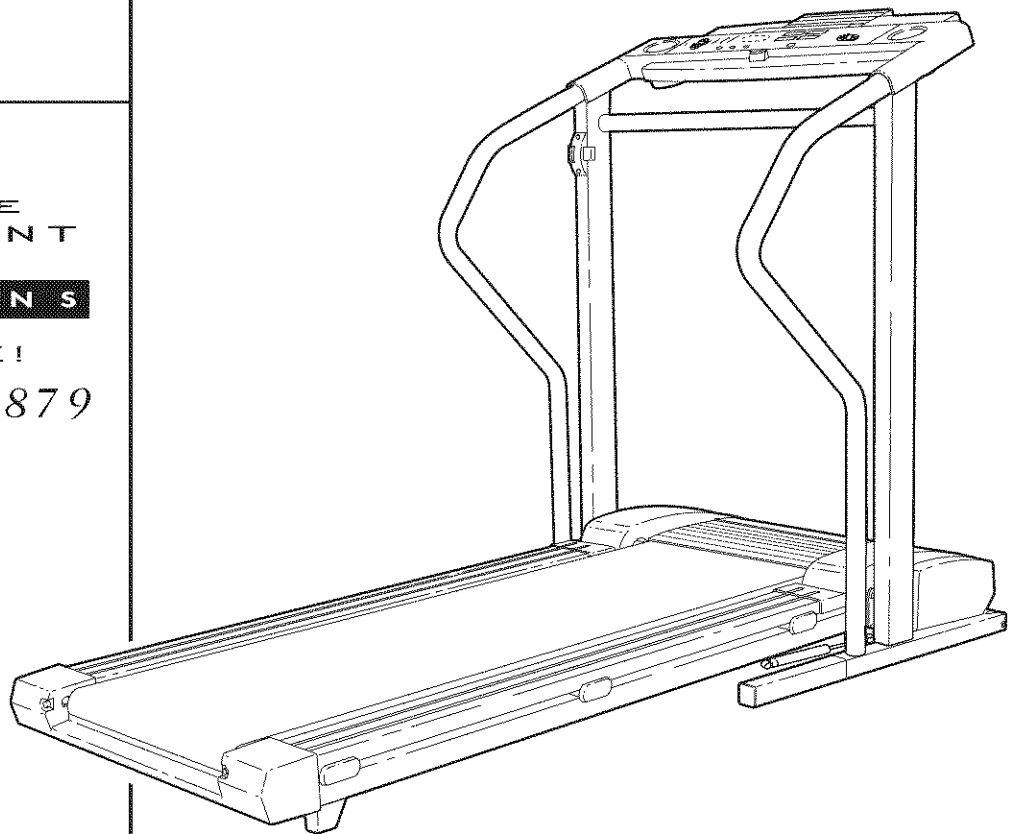

## CAUTION

Read all precautions and instructions in this manual before using this equipment. Save this manual for future reference.

## USER'S MANUAL

SEARS, ROEBUCK AND CO., HOFFMAN ESTATES, IL 60179

---

# TABLE OF CONTENTS

IMPORTANT PRECAUTIONS .....	2
BEFORE YOU BEGIN .....	4
ASSEMBLY .....	5
OPERATION AND ADJUSTMENT .....	7
HOW TO FOLD AND MOVE THE TREADMILL .....	10
TROUBLE-SHOOTING .....	11
CONDITIONING GUIDELINES .....	13
PART LIST .....	15
ORDERING REPLACEMENT PARTS .....	Back Cover
FULL 90-DAY WARRANTY .....	Back Cover

Note: An EXPLODED DRAWING is attached in the center of this manual.

---

## IMPORTANT PRECAUTIONS

**⚠ WARNING:** To reduce the risk of burns, fire, electric shock, or injury to persons, read the following important precautions and information before operating the treadmill.

1. It is the responsibility of the owner to ensure that all users of this treadmill are adequately informed of all warnings and precautions.
2. Use the treadmill only as described in this manual.
3. Place the treadmill on a level surface, with at least eight feet of clearance behind it. Do not place the treadmill on any surface that blocks air openings. To protect the floor or carpet from damage, place a mat under the treadmill.
4. Keep the treadmill indoors, away from moisture and dust. Do not put the treadmill in a garage or covered patio, or near water.
5. Do not operate the treadmill where aerosol products are used or where oxygen is being administered.
6. Keep children under the age of 12 and pets away from the treadmill at all times.
7. The treadmill should not be used by persons weighing more than 250 pounds.
8. Never allow more than one person on the treadmill at a time.
9. Wear appropriate exercise clothing when using the treadmill. Do not wear loose clothing that could become caught in the treadmill. Athletic support clothes are recommended for both men and women. Always wear athletic shoes. Never use the treadmill with bare feet, wearing only stockings, or in sandals.
10. When connecting the power cord (see page 7), plug the power cord into a surge suppressor (not included) and plug the surge suppressor into a grounded circuit capable of carrying 15 or more amps. No other appliance should be on the same circuit. Do not use an extension cord.
11. Use only a single-outlet surge suppressor that is UL 1449 listed as a transient voltage surge suppressor (TVSS). The surge suppressor must have a UL suppressed voltage rating of 400 volts or less and a minimum surge dissipation of 450 joules. The surge suppressor must be electrically rated for 120 volts AC and 15 amps.
12. Keep the power cord and the surge suppressor away from heated surfaces.
13. Never move the walking belt while the power is turned off. Do not operate the treadmill if the power cord or plug is damaged, or if the treadmill is not working properly. (See BEFORE YOU BEGIN on page 4 if the treadmill is not working properly.)

14. Never start the treadmill while you are standing on the walking belt. Always hold the handrails while using the treadmill.
15. The treadmill is capable of high speeds. Adjust the speed in small increments to avoid sudden jumps in speed.
16. Never leave the treadmill unattended while it is running. Always remove the key, and unplug the power cord when the treadmill is not in use.
17. Do not attempt to raise, lower, or move the treadmill until it is properly assembled. (See ASSEMBLY on page 5, and HOW TO MOVE THE TREADMILL on page 10.) You must be able to safely lift 45 pounds (20 kg) in order to raise, lower, or move the treadmill.
18. Do not change the incline of the treadmill by placing objects under the treadmill.
19. When folding or moving the treadmill, make sure that the storage latch is fully closed.
20. Inspect and tighten all parts of the treadmill regularly.
21. Never drop or insert any object into any opening.
22. **DANGER:** Always unplug the power cord immediately after use, before cleaning the treadmill, and before performing the maintenance and adjustment procedures described in this manual. Never remove the motor hood unless instructed to do so by an authorized service representative. Servicing other than the procedures in this manual should be performed by an authorized service representative only.
23. This treadmill is intended for in-home use only. Do not use this treadmill in any commercial, rental, or institutional setting.

**⚠ WARNING:** Before beginning this or any exercise program, consult your physician. This is especially important for persons over the age of 35 or persons with pre-existing health problems. Read all instructions before using. SEARS assumes no responsibility for personal injury or property damage sustained by or through the use of this product.

## SAVE THESE INSTRUCTIONS

The decals shown have been placed on your treadmill. If a decal is missing, or if it is not legible, please call our toll-free HELPLINE to order a free replacement decal. Apply the decal in the location shown.

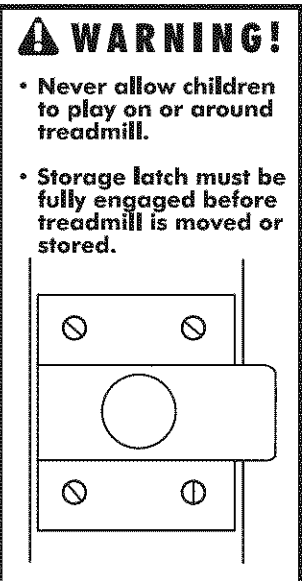
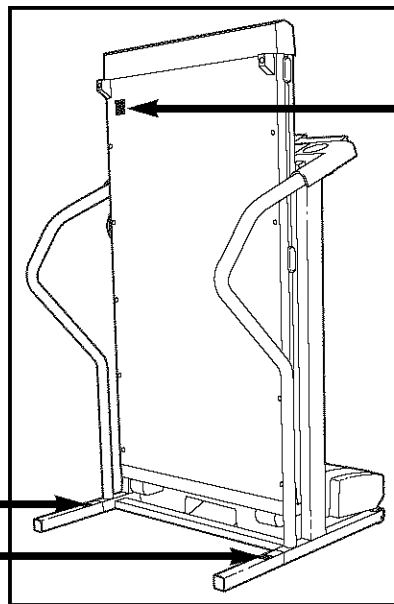

# BEFORE YOU BEGIN

Thank you for selecting the new PROFORM® L18 treadmill. The L18 treadmill combines advanced technology with innovative design to let you enjoy an excellent form of cardiovascular exercise in the convenience and privacy of your home. And when you're not exercising, the unique L18 can be folded up, requiring less than half the floor space of other treadmills.

**For your benefit, read this manual carefully before using the treadmill.** If you have additional questions, please call our toll-free HELPLINE at 1-800-736-6879,

Monday through Saturday, 7 a.m. until 7 p.m. Central Time (excluding holidays). To help us assist you, please note the product model number and serial number before calling. The model number of the treadmill is 831.298072. The serial number can be found on a decal attached to the treadmill (see the front cover of this manual for the location).

Before reading further, please review the drawing below and familiarize yourself with the parts that are labeled.

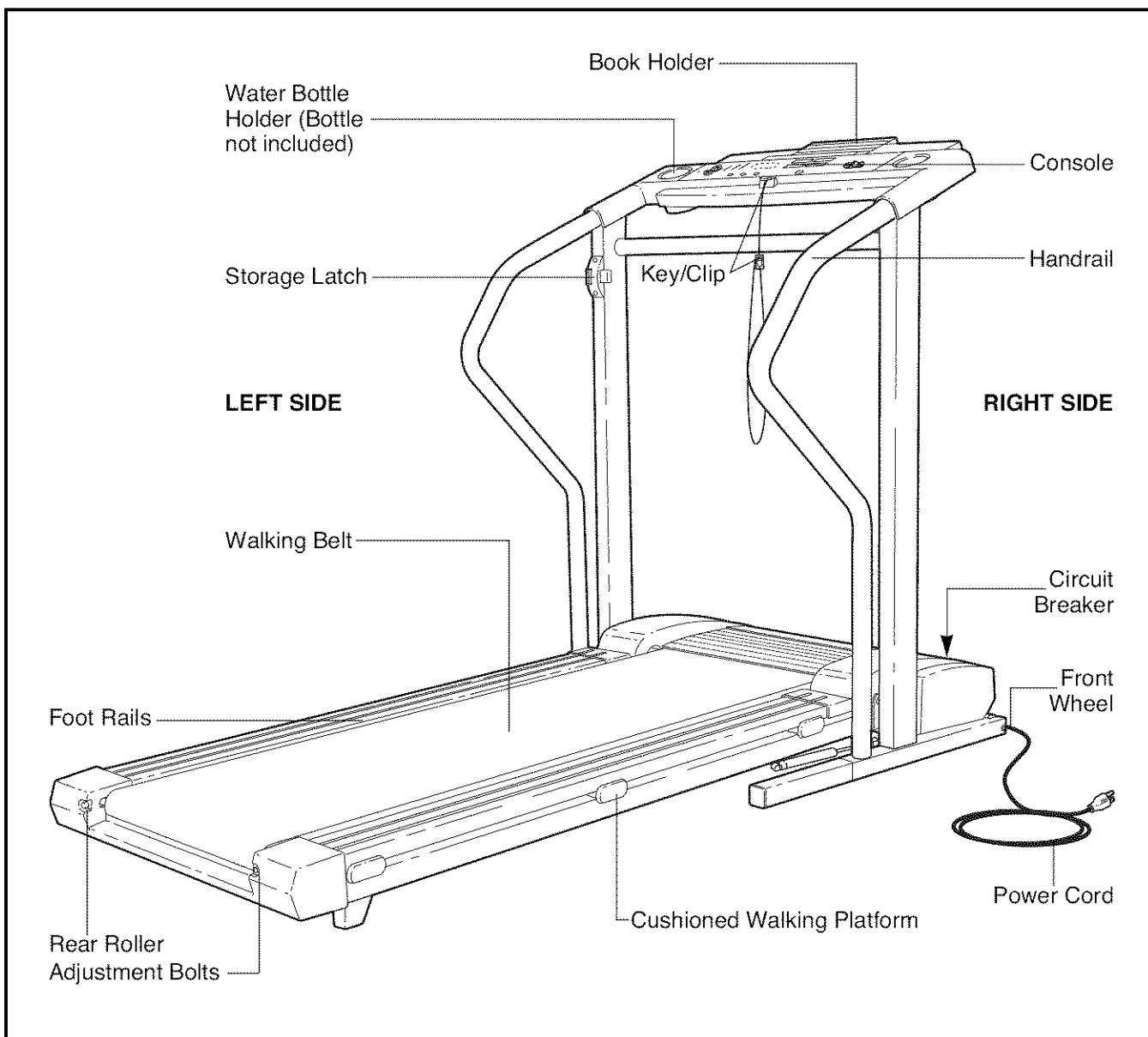

# ASSEMBLY

**Assembly requires two people.** Set the treadmill in a cleared area and remove all packing materials. Do not dispose of the packing materials until assembly is completed. **Assembly requires the included allen wrench and your own phillips screwdriver and adjustable wrench** .

1. With the help of a second person, carefully raise the treadmill to the upright position. While a second person tips the treadmill to one side and holds it, insert one of the Extension Legs (103) into the treadmill as shown. Make sure that the Extension Leg is turned so the Warning Decal (20) is on top.

Next, tip the treadmill to the other side and insert the other Extension Leg (not shown) in the same way. Lower the side of the treadmill so that both Extension Legs (103) are resting flat on the floor.

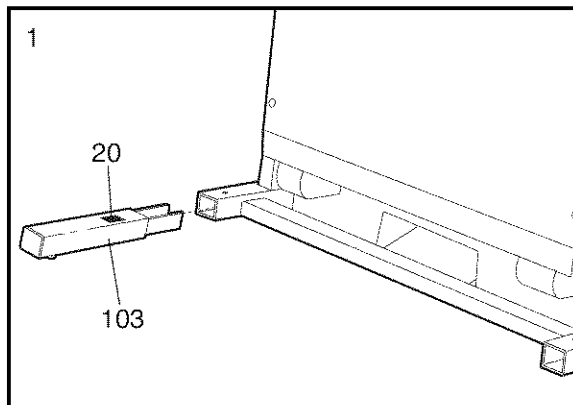

2. Refer to HOW TO LOWER THE TREADMILL FOR USE on page 10. Follow the instructions in step 2 to lower the treadmill.

Attach the latch support to the center hole in the left Upright (82) with a 3/4" Screw (81). **Make sure that the Screw is tight, but do not overtighten it; if the Screw is overtightened, the latch will not slide smoothly.**

Remove the tape from the Latch Assembly (77). **Be careful to hold the parts in place.** Inset drawing (a) shows how the Latch Assembly fits together. Refer to inset drawing (b). Insert the springs into the bracket as shown. Make sure the tabs are touching the bracket and the back end of the latch is flush with the bracket.

Attach the Latch Assembly (77) to the left Upright (82) with two 3/4" Screws (81).

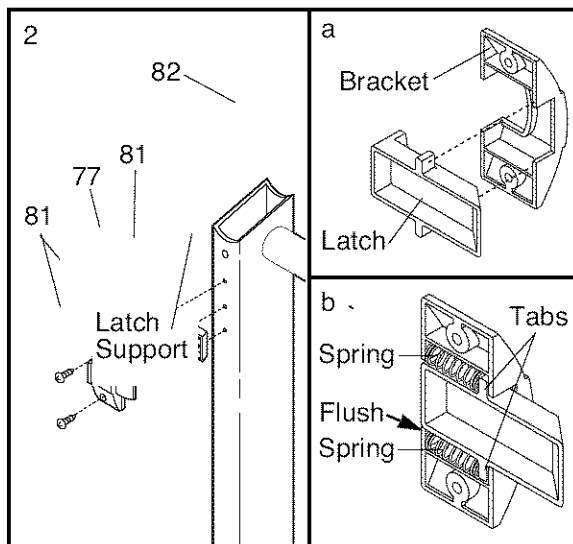

3. Slide the upper end of a Handrail (75) onto the right Upright (82) as shown. **Note: It will be necessary to pivot the Handrail to the side and back repeatedly (see arrow A) while pushing on the Handrail (see arrow B) to slide it fully onto the Upright.** Next, pivot the lower end of the Handrail down, **push it toward the right Upright**, and then align it with the indicated hole.

Slide the other Handrail (75) onto the left Upright (82) as described above.

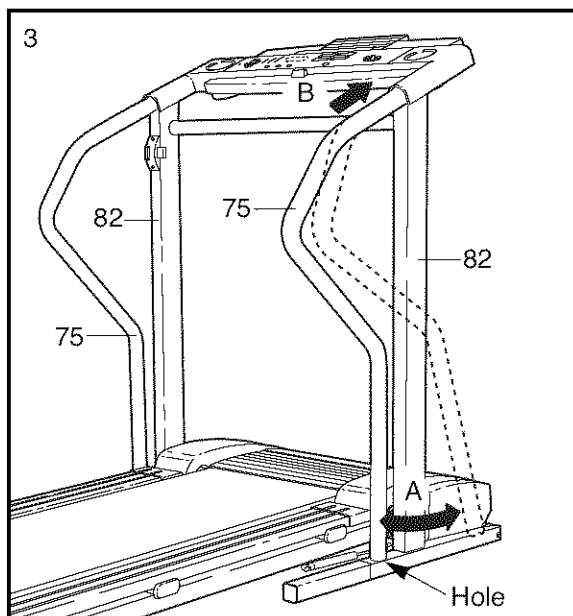

4. With the help of a second person, carefully tip the Uprights (82) down as shown. **Make sure the Extension Legs (103) remain inserted into the Uprights.** Attach one of the Extension Legs with two of the four Short Screws (101) as shown. Attach the other Extension Leg in the same way.

Tighten a Handrail Bolt (78) with a Handrail Washer (96) into the right Upright (82) and the lower end of the right Handrail (75) as shown. Note: Refer to drawing 4b. To align the hole in the Handrail (75) with the hole in the Upright (82), it may be necessary to have a second person place one foot on the treadmill as they lift the Handrail. Insert the Handrail Bolt when the holes are aligned.

Next, tighten a Handrail Bolt (78) with a Handrail Washer (96) into the left Upright (82) and the lower end of the left Handrail (not shown).

With the help of a second person, carefully tip the Uprights (82) back to the upright position.

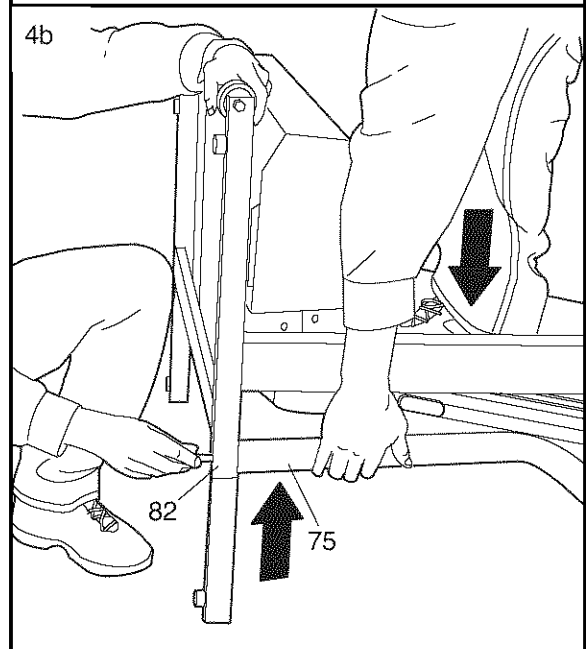
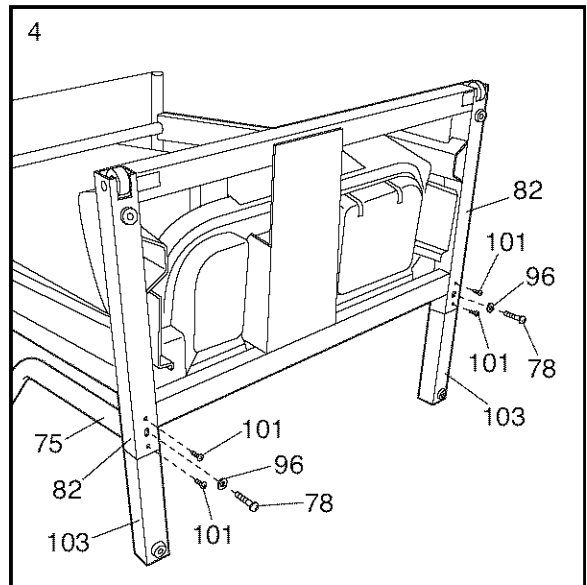

5. Remove the backing from the Wrench Clip (99). Press the Wrench Clip onto the base of the right Upright (82) as shown. Press the Allen Wrench (100) into the Wrench Clip.

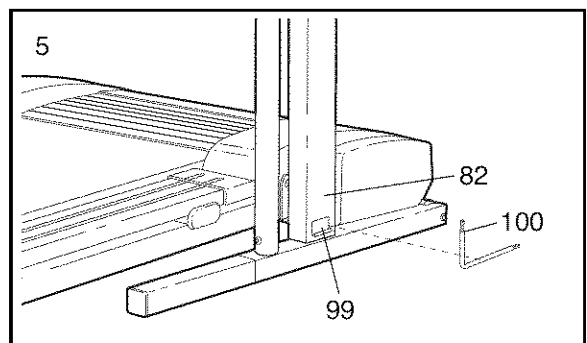

6. **Make sure that all parts are tightened before you use the treadmill.** To protect the floor or carpet, place a mat under the treadmill.

# OPERATION AND ADJUSTMENT

## THE PERFORMANT LUBE™ WALKING BELT

Your treadmill features a walking belt coated with PERFORMANT LUBE™, a high-performance lubricant.

**IMPORTANT: Never apply silicone spray or other substances to the walking belt or the walking platform. Such substances will deteriorate the walking belt and cause excessive wear.**

## HOW TO PLUG IN THE POWER CORD

**⚠ DANGER:** Improper connection of the equipment-grounding conductor can result in an increased risk of electric shock. Check with a qualified electrician or serviceman if you are in doubt as to whether the product is properly grounded. Do not modify the plug provided with the product—if it will not fit the outlet, have a proper outlet installed by a qualified electrician.

Your treadmill, like any other type of sophisticated electronic equipment, can be seriously damaged by sudden voltage changes in your home's power. Voltage surges, spikes, and noise interference can result from weather conditions or from other appliances being turned on or off. **To decrease the possibility of your treadmill being damaged, always use a surge suppressor with your treadmill (see drawing 1 at the right).**

Surge suppressors are sold at most hardware stores and department stores. Use only a single-outlet surge suppressor that is UL 1449 listed as a transient voltage surge suppressor (TVSS). The surge suppressor must have a UL suppressed voltage rating of 400 volts or less and a minimum surge dissipation of 450 joules. The surge suppressor must be electrically rated for 120 volts AC and 15 amps.

**This product must be grounded.** If it should malfunction or break down, grounding provides a path of least resistance for electric current to reduce the risk of electric shock. This product is equipped with a cord having an equipment-grounding conductor and a grounding plug. **Plug the power cord into a surge suppressor, and plug the surge suppressor into an appropriate outlet that is properly installed and grounded in accordance with all local codes and ordinances.**

This product is for use on a nominal 120-volt circuit, and has a grounding plug that looks like the plug illustrated in drawing 1 below. A temporary adapter that looks like the adapter illustrated in drawing 2 may be used to connect the surge suppressor to a 2-pole receptacle as shown in drawing 2 if a properly grounded outlet is not available.

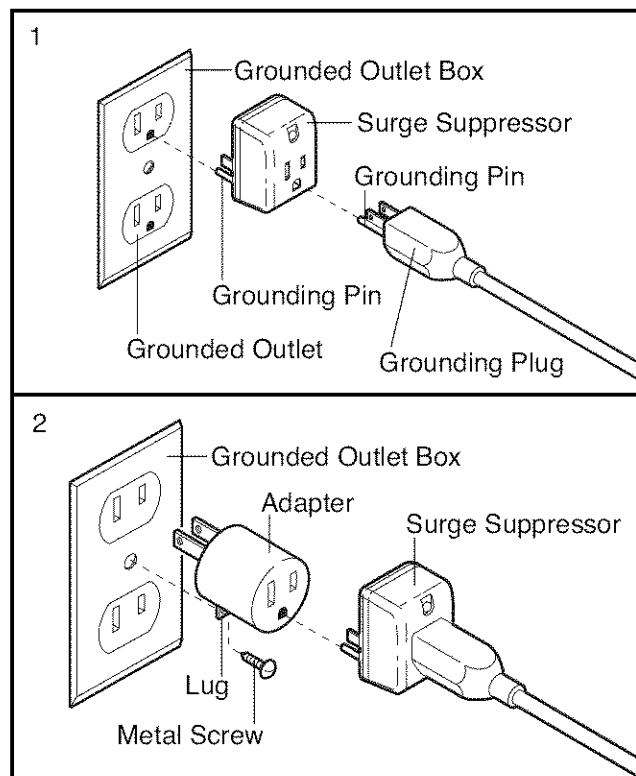

The temporary adapter should be used only until a properly grounded outlet (drawing 1) can be installed by a qualified electrician.

The green-colored rigid ear, lug, or the like extending from the adapter must be connected to a permanent ground such as a properly grounded outlet box cover. Whenever the adapter is used it must be held in place by a metal screw. **Some 2-pole receptacle outlet box covers are not grounded. Contact a qualified electrician to determine if the outlet box cover is grounded before using an adapter.**

## CONSOLE DIAGRAM

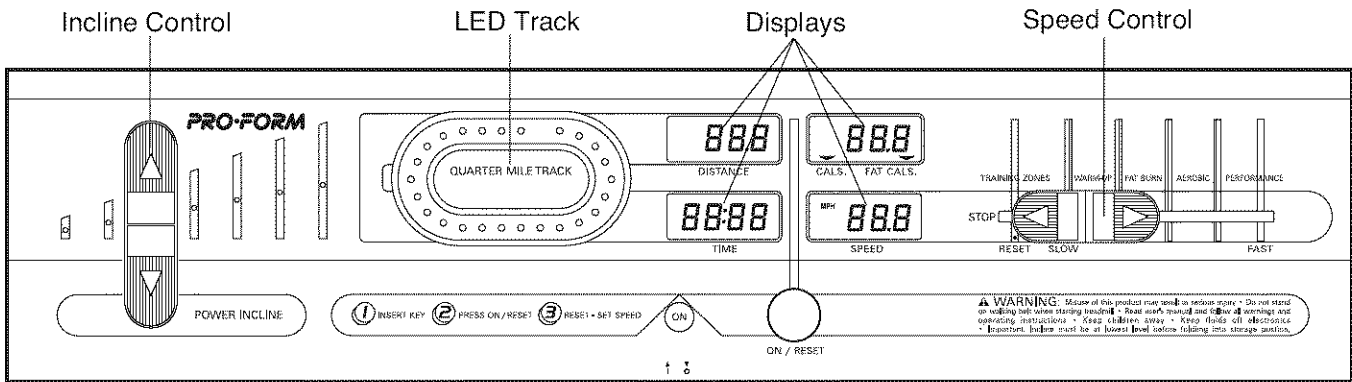

**Note:** If there is a thin sheet of clear plastic on the face of the console, remove it.

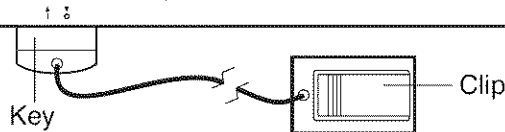

### **CAUTION:** Before operating the console, read the following precautions.

- Do not stand on the walking belt when turning on the power.
- Always wear the clip (see the drawing at the lower right) while using the treadmill. When the key is removed from the console, the walking belt will stop.
- Adjust the speed in small increments.
- The training zones marked above the speed control are general guidelines only. See page 13 for more information.
- To reduce the possibility of electric shock, keep the console dry. Avoid spilling liquids on the console and use only a sealable water bottle.

## BATTERY INSTALLATION

The console requires two "AA" batteries (not included). Alkaline batteries are recommended. Open the battery cover as shown in the drawing at the upper right. Insert two batteries into the battery compartment, making sure that the negative (-) ends of the batteries

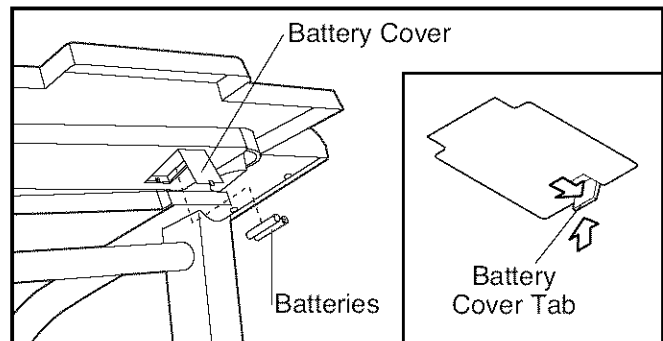

are touching the springs in the battery compartment. Close the battery cover, push up on the battery cover tab, and then push the tab forward as shown in the inset drawing. Be sure that the tab locks into place.

## STEP-BY-STEP CONSOLE OPERATION

Before operating the console, make sure that the power cord is properly plugged in. (See HOW TO PLUG IN THE POWER CORD on page 7.)

Next, step onto the foot rails of the treadmill. Find the clip attached to the key, and slide the clip onto the waistband of your clothing.

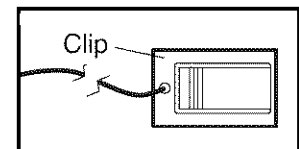

Follow the steps on page 9 to operate the console.



**1** Insert the key fully into the power switch.

Inserting the key will not turn on the displays. The displays will turn on when the ON/RESET button is pressed or when the walking belt is started. Note: If you just installed batteries, the displays will already be on.

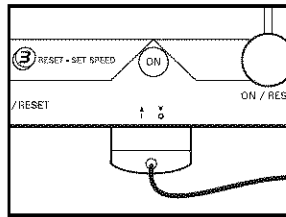

**2** Reset the speed control.

Slide the speed control to the RESET position. Note: Each time the walking belt is stopped, the speed control must be moved to the RESET position before the walking belt can be restarted.

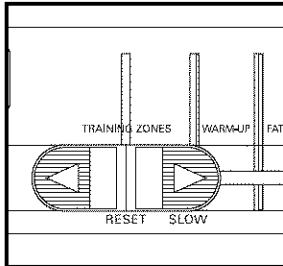

**3** Start the walking belt.

After you have moved the speed control to the RESET position, slowly slide it to the right until the walking belt begins to move at slow speed. Carefully step onto the walking belt and begin exercising. Change the speed of the walking belt as desired by sliding the speed control.

To stop the walking belt, step onto the foot rails and slide the speed control to the RESET position.

**4** Adjust the incline of the treadmill as desired.

To change the incline of the treadmill, press the top or bottom of the incline control until the desired incline level is reached.

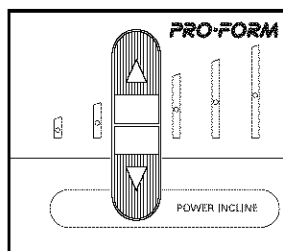

**5** Follow your progress with the LED track and the four displays.

The LED Track—The LED track represents a distance of 1/4 mile. As you exercise, the indicators around the track will light one at a time until you have com-

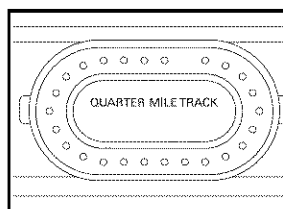

pleted 1/4 mile. A new lap will then begin.

**DISTANCE display**— This display shows the distance that you have walked or run, in miles.

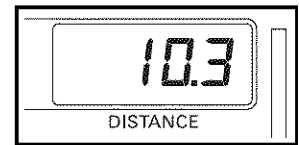

**CALS/FAT CALS display**— This display shows the approximate numbers of calories and fat calories you have burned. (See FAT BURNING on page 13.)

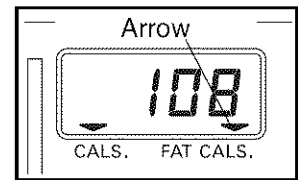

Every seven seconds, the display will change from one number to the other. Arrows in the display will indicate which number is currently shown.

**SPEED display**— This display shows the speed of the walking belt, in miles per hour.

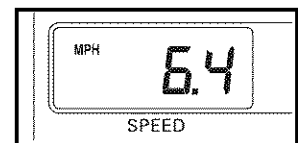

**TIME display**— This display shows the elapsed time.



To reset the displays at any time, press the ON/RESET button.

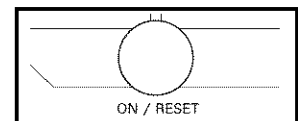

**6** When you are finished exercising, stop the walking belt and remove the key.

Step onto the foot rails, stop the walking belt and remove the key from the console. The displays will turn off about five minutes after the key is removed.

Note: To conserve the batteries, the displays will automatically turn off any time that the walking belt is stopped and the ON/RESET button is not pressed for five minutes.

# HOW TO FOLD AND MOVE THE TREADMILL

## HOW TO FOLD THE TREADMILL FOR STORAGE

Before folding the treadmill, adjust the incline to the lowest position. If this is not done, the treadmill may be permanently damaged. Next, unplug the power cord.

**CAUTION:** You must be able to safely lift 45 pounds (20 kg) in order to raise, lower, or move the treadmill.

1. Hold the treadmill with your hands in the locations shown at the right. **CAUTION: To decrease the possibility of injury, bend your legs and keep your back straight. As you raise the treadmill, make sure to lift with your legs rather than your back.** Raise the treadmill about halfway to the vertical position.

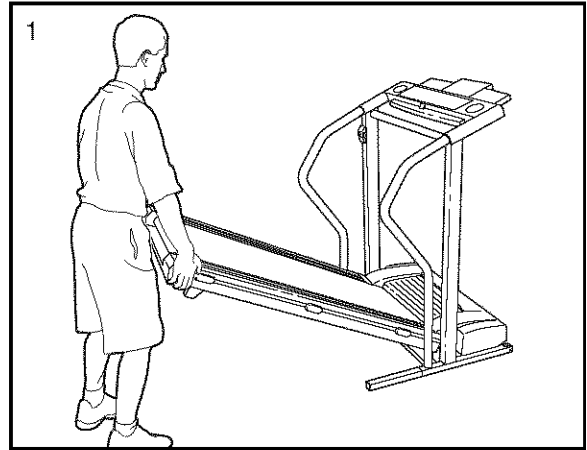

2. Move your right hand to the position shown and hold the treadmill firmly. Using your left thumb, slide the storage latch to the left and hold it. Raise the treadmill until the storage latch closes over the catch. **Make sure that the storage latch is fully closed over the latch catch.**

To protect the floor or carpet from damage, place a mat under the treadmill. Keep the treadmill out of direct sunlight. Do not leave the treadmill in the storage position in temperatures above 85° Fahrenheit.

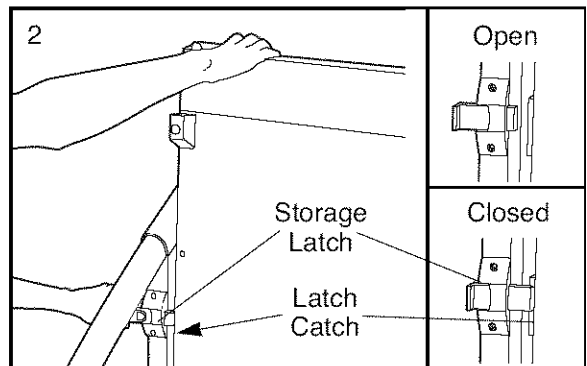

## HOW TO MOVE THE TREADMILL

Before moving the treadmill, convert the treadmill to the storage position as described above. **Make sure that the storage latch is closed fully over the catch.**

1. Hold the handrails as shown and place one foot against a wheel. **Do not hold or push on the book holder or the book holder may be damaged.**
2. Tilt the treadmill back until it rolls freely on the front wheels. Carefully move the treadmill to the desired location. **Never move the treadmill without tipping it back. To reduce the risk of injury, use extreme caution while moving the treadmill. Do not attempt to move the treadmill over an uneven surface.**
3. Place one foot on the base, and carefully lower the treadmill until it is resting in the storage position.

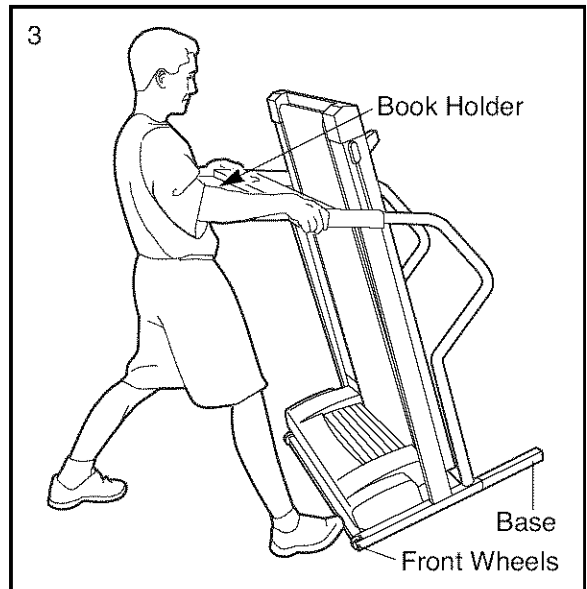

## HOW TO LOWER THE TREADMILL FOR USE

1. Refer to drawing 2 above. Hold the upper end of the treadmill with your right hand as shown. Using your left thumb, slide the storage latch to the left and hold it. Pivot the treadmill down until the frame is past the storage latch.
2. Refer to drawing 1 above. Hold the treadmill firmly with both hands, and lower the treadmill to the floor. **CAUTION: To decrease the possibility of injury, bend your legs and keep your back straight.**

# TROUBLE-SHOOTING

Most treadmill problems can be solved by following the simple steps below. Find the symptom that applies, and follow the steps listed. If further assistance is needed, call our toll-free HELPLINE at 1-800-736-6879, Monday through Saturday, 7 a.m. until 7 p.m. Central Time (excluding holidays).

## 1. SYMPTOM: THE POWER DOES NOT TURN ON

- a. Make sure that the power cord is plugged into a surge suppressor, and that the surge suppressor is plugged into a properly grounded outlet (see page 7). Use only a single-outlet surge suppressor that is UL 1449 listed as a transient voltage surge suppressor (TVSS). The surge suppressor must have a UL suppressed voltage rating of 400 volts or less and a minimum surge dissipation of 450 joules. The surge suppressor must be electrically rated for 120 volts AC and 15 amps.
- b. After the power cord has been plugged in, make sure that the key is fully inserted into the console. See step 1 on page 8.
- c. Check the circuit breaker located on the treadmill near the power cord. If the switch protrudes as shown, the circuit breaker has tripped. To reset the circuit breaker, wait for five minutes and then press the switch back in.

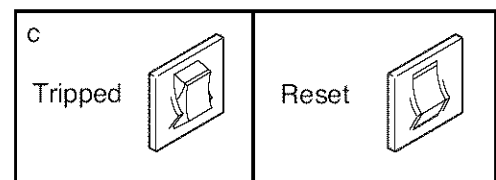

## 2. SYMPTOM: THE POWER TURNS OFF DURING USE

- a. Check the circuit breaker located on the treadmill frame near the power cord (see 1. c. above). If the circuit breaker has tripped, wait for five minutes and then press the switch back in.
- b. Make sure that the power cord is plugged in.
- c. Remove the key from the console. Reinsert the key fully into the console. See step 1 on page 9.
- d. If the treadmill still will not run, please call our toll-free HELPLINE.

## 3. SYMPTOM: THE DISPLAYS OF THE CONSOLE DO NOT FUNCTION PROPERLY

- a. Remove the six screws from the hood. Carefully remove the hood. Locate the Reed Switch (21) and the Magnet (43) on the left side of the Pulley (42). Turn the Pulley until the Magnet is aligned with the Reed Switch. **Make sure that the gap between the Magnet and the Reed Switch is about 1/8"**. If necessary, loosen the Reed Switch Screw (76) and move the Reed Switch slightly. Retighten the Screw. Re-attach the hood, and run the treadmill for a few minutes to check for a correct speed reading.

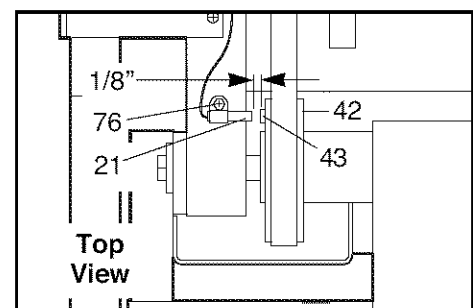

**PROBLEM: The walking belt slows when walked on**

**SOLUTION:** a. Use only a UL-listed surge suppressor, rated at 15 amps, with a 14-gauge cord of five feet or less in length.

b. If the walking belt is overtightened, treadmill performance may decrease and the walking belt may be permanently damaged. Remove the key and **UNPLUG THE POWER CORD**. Using the allen wrench, turn both rear roller adjustment bolts counterclockwise, 1/4 of a turn. When the walking belt is properly tightened, you should be able to lift each side of the walking belt 3 to 4 inches off the walking platform. Be careful to keep the walking belt centered. Plug in the power cord, insert the key and run the treadmill for a few minutes. Repeat until the walking belt is properly tightened.

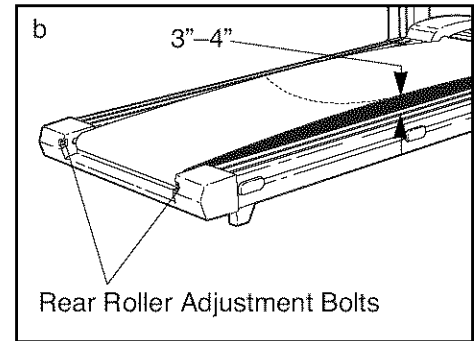

c. If the walking belt still slows when walked on, please call our toll-free HELPLINE.

**PROBLEM: The walking belt is off-center when walked on**

**SOLUTION:** a. If the walking belt has shifted to the left, first remove the key and **UNPLUG THE POWER CORD**. Using the allen wrench, turn the left rear roller adjustment bolt clockwise, and the right bolt counterclockwise, 1/4 of a turn each. Be careful not to overtighten the walking belt. Plug in the power cord, insert the key and run the treadmill for a few minutes. Repeat until the walking belt is centered.

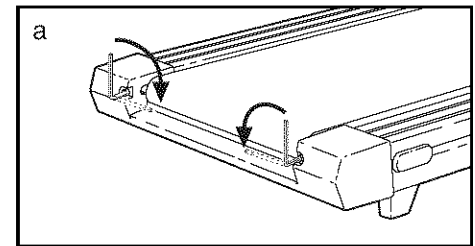

b. If the walking belt has shifted to the right, first remove the key and **UNPLUG THE POWER CORD**. Using the allen wrench, turn the left rear roller adjustment bolt counterclockwise, and the right bolt clockwise, 1/4 of a turn each. Be careful not to overtighten the walking belt. Plug in the power cord, insert the key and run the treadmill for a few minutes. Repeat until the walking belt is centered.

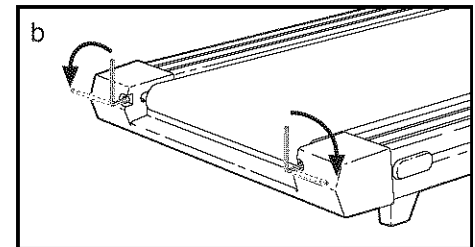

**PROBLEM: The walking belt slips when walked on**

**SOLUTION:** a. If the walking belt slips when walked on, first remove the key and **UNPLUG THE POWER CORD**. Using the allen wrench, turn both rear roller adjustment bolts clockwise, 1/4 of a turn. When the walking belt is correctly tightened, you should be able to lift each side of the walking belt 3 to 4 inches off the walking platform. Be careful to keep the walking belt centered. Plug in the power cord, insert the key and carefully walk on the treadmill for a few minutes. Repeat until the walking belt is properly tightened.

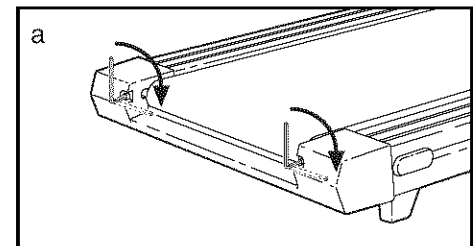

# CONDITIONING GUIDELINES

**WARNING:** Before beginning this or any exercise program, consult your physician. This is especially important for individuals over the age of 35 or individuals with pre-existing health problems.

The following guidelines will help you to plan your exercise program. Remember—these are general guidelines only. For more detailed exercise information, obtain a reputable book or consult your physician.

## EXERCISE INTENSITY

Whether your goal is to burn fat or to strengthen your cardiovascular system, the key to achieving the desired results is to exercise with the proper intensity. The proper intensity level can be found by using your heart rate as a guide. The chart below shows recommended heart rates for fat burning and aerobic exercise. (This chart is also found on the console.)

HEART RATE TRAINING ZONE			
	MIN BPM	MAX BPM	
AGE	Fat Burn	Max Burn	Aerobic
20	125	145	165
30	120	138	155
40	115	130	145
50	110	125	140
60	105	118	130
70	95	110	125
80	90	103	115

To find the proper heart rate for you, first find your age on the left side of the chart (ages are rounded off to the nearest ten years). Next, find the three numbers to the right of your age. The three numbers are your “training zone.” The lower two numbers are recommended heart rates for fat burning; the higher number is the recommended heart rate for aerobic exercise.

### Fat Burning

To burn fat effectively, you must exercise at a relatively low intensity level for a sustained period of time. During the first few minutes of exercise, your body uses easily accessible carbohydrate calories for energy. Only after the first few minutes does your body begin to use stored fat calories for energy. If your goal is to burn fat, adjust the speed and incline of the treadmill until your heart rate is near one of the lower two numbers in your

training zone. It may also be helpful to set the speed control on the console to FAT BURN to help you maintain the proper intensity level. (See page 9.)

### Aerobic Exercise

If your goal is to strengthen your cardiovascular system, your exercise must be “aerobic.” Aerobic exercise is activity that requires large amounts of oxygen for prolonged periods of time. This increases the demand on the heart to pump blood to the muscles, and on the lungs to oxygenate the blood. For aerobic exercise, adjust the speed and incline of the treadmill until your heart rate is near the highest number in your training zone. It may also be helpful to set the speed control on the console to AEROBIC to help you maintain the proper intensity level. (See page 9.)

### High Performance Athletic Conditioning

If your goal is high performance athletic conditioning, set the speed control on the console to PERFORMANCE to help you maintain the proper intensity level. (See page 9.) Note: During the first few weeks of your exercise program, keep your heart rate near the low end of your training zone.

## HOW TO MEASURE YOUR HEART RATE

To measure your heart rate, stop exercising and place two fingers on your wrist as shown. Take a six-second heartbeat count, and multiply the result by ten to find your heart

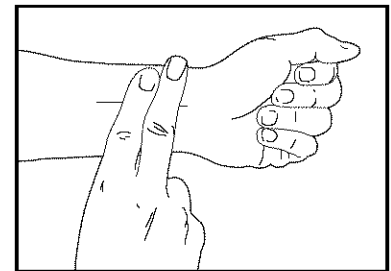

rate. (A six-second count is used because your heart rate drops quickly when you stop exercising.) If your heart rate is too high or too low, adjust the speed or incline of the treadmill accordingly.

## WORKOUT GUIDELINES

A well-rounded workout includes the following three important parts:

### A Warm-up

Start each workout with 5 to 10 minutes of stretching and light exercise (see SUGGESTED STRETCHES on page 14). A proper warm-up increases your body temperature, heart rate, and circulation in preparation for exercise.

## Training Zone Exercise

After warming up, increase the intensity of your exercise until your pulse is in your training zone for 20 to 60 minutes. (During the first few weeks of your exercise program, do not keep your pulse in your training zone for longer than 20 minutes.) Breathe regularly and deeply as you exercise—never hold your breath.

## A Cool-down

Finish each workout with 5 to 10 minutes of stretching

to cool down. This will increase the flexibility of your muscles and will help to prevent post-exercise problems.

## Exercise Frequency

To maintain or improve your condition, complete three workouts each week, with at least one day of rest between workouts. After a few months, you may complete up to five workouts each week if desired.

The key to success is to make exercise a regular and enjoyable part of your everyday life.

## SUGGESTED STRETCHES

The correct form for several basic stretches is shown in the drawings below. Move slowly as you stretch—never bounce.

### 1. Toe Touch Stretch

Stand with your knees bent slightly and slowly bend forward from your hips. Allow your back and shoulders to relax as you reach down toward your toes as far as possible. Hold for 15 counts, then relax. Repeat 3 times. Stretches: Hamstrings, back of knees, and back.

### 2. Hamstring Stretch

Sit with one leg extended. Bring the sole of the opposite foot toward you and rest it against the inner thigh of your extended leg. Reach toward your toes as far as possible. Hold for 15 counts, then relax. Repeat 3 times for each leg. Stretches: Hamstrings, lower back, and groin.

### 3. Calf/Achilles Stretch

With one leg in front of the other, reach forward and place your hands against a wall. Keep your back leg straight and your back foot flat on the floor. Bend your front leg, lean forward and move your hips toward the wall. Hold for 15 counts, then relax. Repeat 3 times for each leg. To cause further stretching of the achilles tendons, bend your back leg as well. Stretches: Calves, achilles tendons, and ankles.

### 4. Quadriceps Stretch

With one hand against a wall for balance, reach back and grasp one foot with your other hand. Bring your heel as close to your buttocks as possible. Hold for 15 counts, then relax. Repeat 3 times for both legs. Stretches: Quadriceps and hip muscles.

### 5. Inner Thigh Stretch

Sit with the soles of your feet together and your knees outward. Pull your feet toward your groin area as far as possible. Hold for 15 counts, then relax. Repeat 3 times. Stretches: Quadriceps and hip muscles.

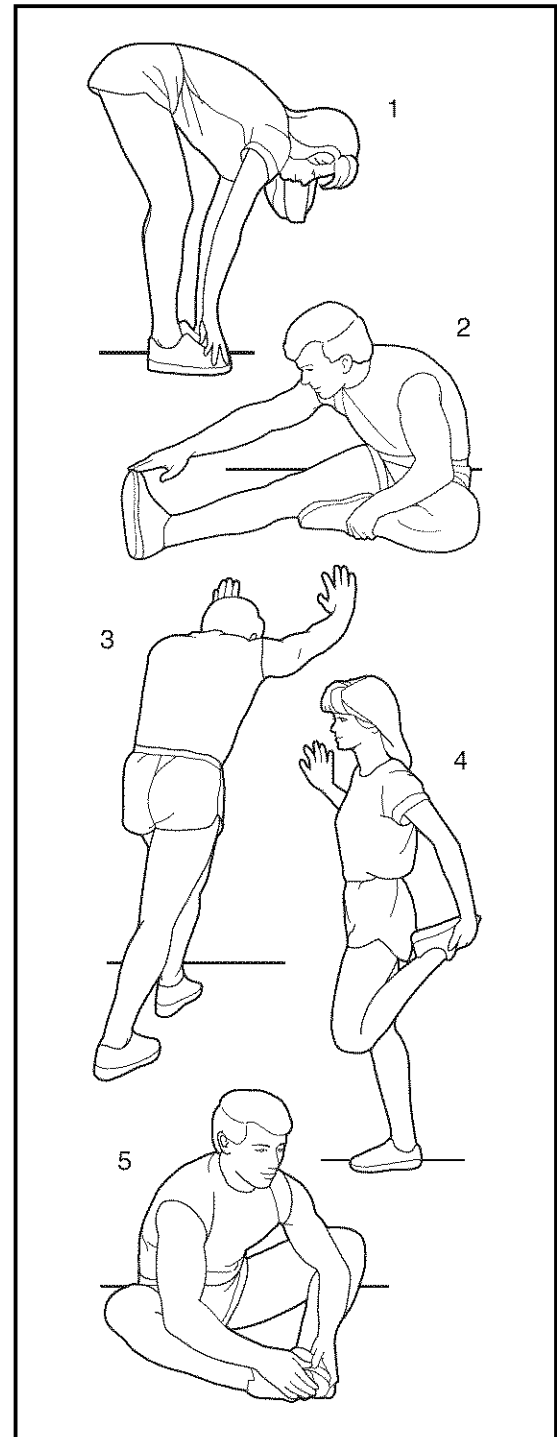

# PART LIST—Model No. 831.298072

R0199A

Key No.	Qty.	Description	Key No.	Qty.	Description
1	1	Motor Belt	63	1	Belly Pan
2	1	Pulley/Flywheel/Fan	64	1	Rear Endcap
3	4	Motor Nut	65	2	Rear Roller Adj. Bolt
4*	1	Motor/Pulley/Flywheel/Fan	66	1	Motor
5	3	Incline Motor Bolt	67	1	Latch Decal
6	1	Incline Motor Spacer	68	4	Rear Platform Screw
7	1	Incline Motor	69	2	Catch Screw
8	1	Stop Bracket	70	1	Latch Catch
9	1	Small Nut	71	1	Walking Platform
10	2	Star Washer	72	5	8" cable Tie
11	1	Optic Switch	73	4	4" cable Tie
12	1	Frame	74	1	Front Roller Adj. Nut
13	1	Small Bolt	75	2	Handrail
14	1	Incline Optic Disk	76	7	Reed Switch Screw/Belly Pan Screw
15	8	Incline Motor Nut	77	1	Storage Latch
16	16	Screw	78	2	Handrail Bolt
17	4	Plastic Stand-Off	79	4	Long Screw
18	2	Hood Bracket (short)	80	1	Speed Control
19	2	Hood Bracket (long)	81	2	3/4" Screw
20	2	Warning Decal	82	1	Upright
21	1	Reed Switch	83	2	Incline Leg Pivot Bolt
22	1	Reed Switch Clip	84	2	Incline Leg Pivot Washer
23	1	Motor/Controller Wire	85	1	Incline Control
24	1	Controller	86	2	Wheel Bolt
25	1	Electronics Bracket	87	1	Console Base
26	1	Circuit Breaker	88*	1	Console
27	1	Power Cord	89	8	Console Screw
28	1	Power Cord Grommet	90	1	Key/Clip
29	4	Motor Star Washer	91	1	Incline Motor Plate
30	1	Inlet Bracket	92	2	Wheel Nut
31	1	Incline Leg	93	6	Hood Screw
32	2	Frame Pivot Bolt	94	1	Motor Hood
33	2	Frame Pivot Spacer	95	2	Front Wheel
34	3	Hood Bracket Clip	96	4	Handrail Washer
35	1	Front Roller Adj. Bolt	97	4	Base Pad
36	3	Roller Adj. Washer	98	4	Base Pad Screw
37	1	Choke	99	1	Wrench Clip
38	4	Motor Bolt	100	1	Allen Wrench
39	2	Cap Screw	101	8	Short Screw
40	1	Left Foot Rail Cap	102	1	Upright Hole Plug
41	2	Foot Rail	103	2	Extension Leg
42	1	Front Roller/Pulley	104	2	Extension Leg Cap
43	1	Magnet	105	1	Shock
44	4	Platform Screw	106	1	Upright Grommet
45	4	Isolator	107	1	Incline Motor Shield
46	4	Isolator Screw	108	1	Book Holder
47	17	Belly Pan Fastener	109	1	Right Foot Rail Cap
48	1	Wire Harness	110	4	Endcap Clip
49	2	Belt Guide	111	2	Foot Rail Insert
50	1	Console Cover	112	1	Motor Tension Nut
51	1	Front Belly Pan	113	1	Motor Tension Bolt
52	1	Power Supply	#	1	8" Blue Wire, 2 Female
53	2	Cable Tie Clamp	#	1	4" Blue Wire, 2 Female
54	1	Cable Tie	#	1	10" White Wire, 2 Female
55	1	Walking Belt	#	1	4" White Wire, Male/Female
56	2	Roller Guard	#	1	9" Wire Harness
57	1	Rear Roller	#	1	4" Black Wire Harness, 2 Female
58	2	Rear Isolator	#	1	4" Green Wire, F/Ring
59	2	Rear Foot	#	1	User's Manual
60	2	Rear Foot Screw			
61	1	Ground Wire			
62	1	Ground Wire Screw			

\* Includes all parts shown in the box

# These parts are not illustrated

# EXPLODED DRAWING—Model No. 831.298072

R0199A

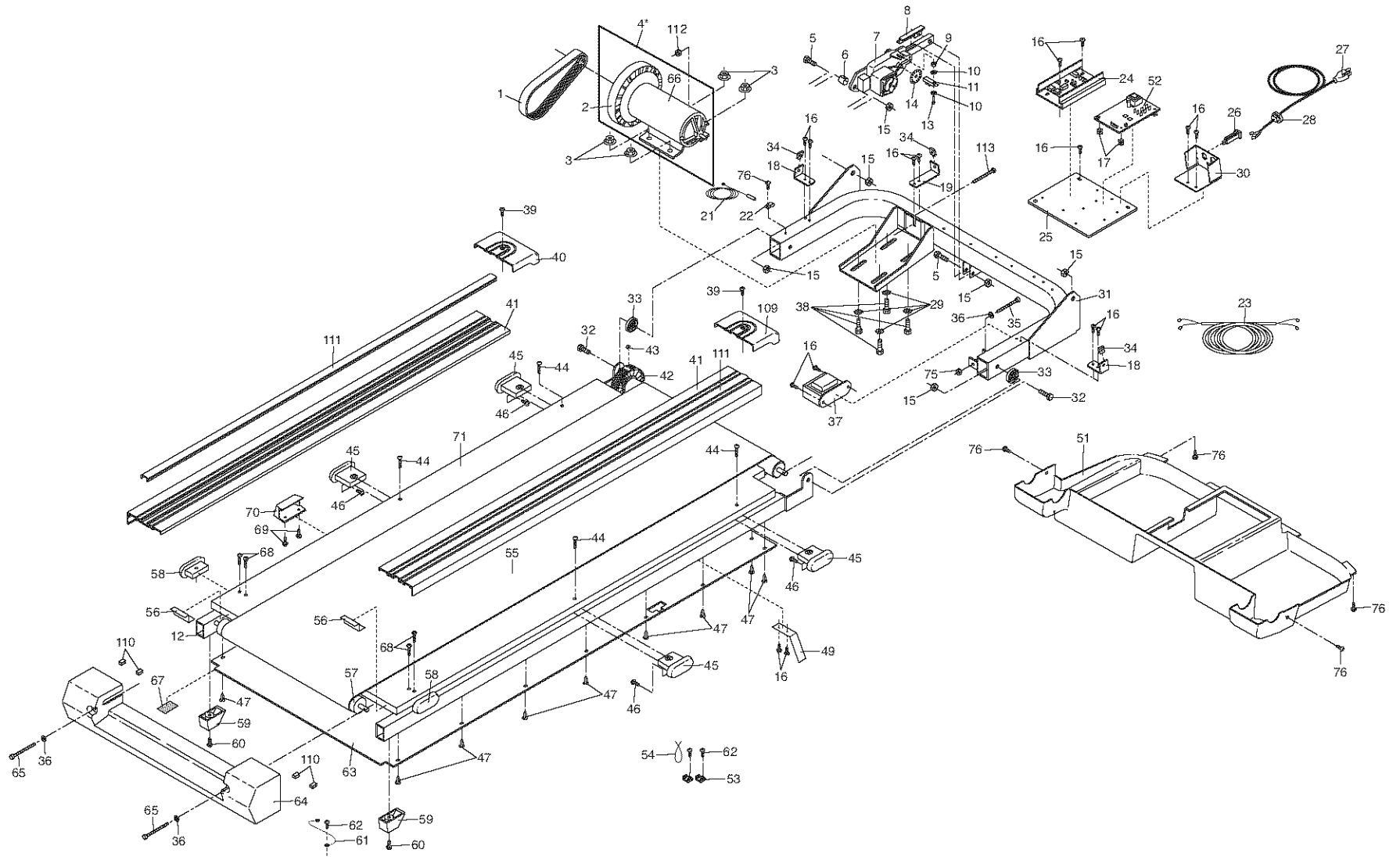



# EXPLODED DRAWING—Model No. 831.298072

R0199A

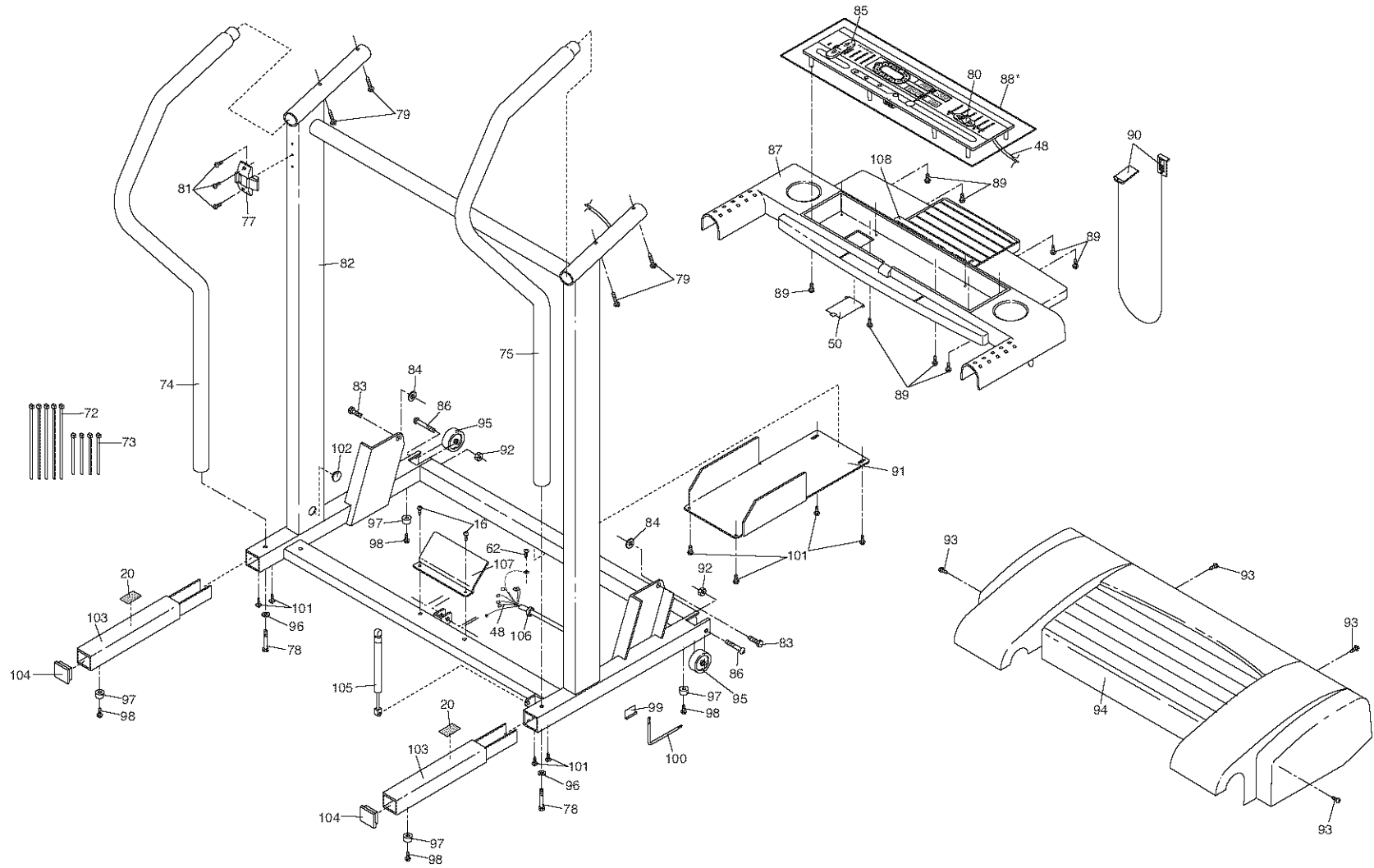



Model No. 831.298072

## QUESTIONS?

If you find that:

- you need help assembling or operating the PROFORM L18 treadmill
- a part is missing
- or you need to schedule repair service

call our toll-free HELPLINE

**1-800-736-6879**

Monday–Saturday, 7 am–7 pm  
Central Time (excluding holidays)

## REPLACEMENT PARTS

If parts become worn and need to be replaced, call the following toll-free number

**1-800-FON-PART**  
**(1-800-366-7278)**

The model number and serial number of your PROFORM® L18 treadmill are listed on a decal attached to the frame. See the front cover of this manual to find the location of the decal.

All replacement parts are available for immediate purchase or special order when you visit your nearest SEARS Service Center. To request service or to order parts by telephone, call the toll-free numbers listed at the left.

When requesting help or service, or ordering parts, please be prepared to provide the following information:

- The NAME OF THE PRODUCT (PROFORM® L18 treadmill)
- The MODEL NUMBER OF THE PRODUCT (831.298072)
- The KEY NUMBER AND DESCRIPTION OF THE PART (see the EXPLODED DRAWING and PART LIST included in this manual)

## FULL 90 DAY WARRANTY

For 90 days from the date of purchase, if failure occurs due to defect in material or workmanship in this SEARS TREADMILL EXERCISER, contact the nearest SEARS Service Center throughout the United States and SEARS will repair or replace the TREADMILL EXERCISER, free of charge.

This warranty does not apply when the TREADMILL EXERCISER is used commercially or for rental purposes.

This warranty gives you specific legal rights, and you may also have other rights which vary from state to state.

**SEARS, ROEBUCK AND CO., DEPT. 817WA, HOFFMAN ESTATES, IL 60179**