

SEARS

CRAFTSMAN®

MODEL NUMBER 917.256611 OWNER'S MANUAL

- Assembly
- Operation
- Customer Responsibilities
- Service and Adjustments
- Repair Parts

EZ³

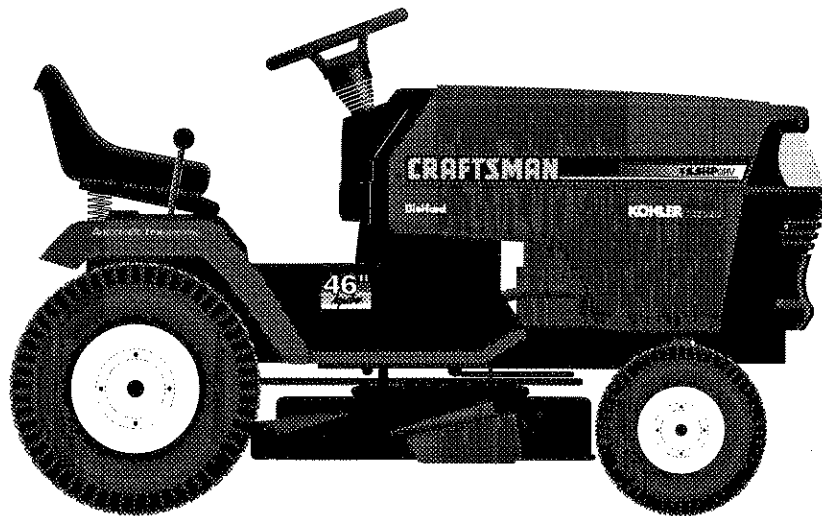

This product has a low emission engine which operates differently from previously built engines. Before you start the engine, read and understand this Owner's Manual.

CAUTION: Read and follow all safety rules and instructions before operating this equipment.
FOR CONSUMER ASSISTANCE HOT LINE, CALL THIS TOLL FREE NUMBER: 1-800-659-5917

Sears, Roebuck and Co., Hoffman Estates, IL 60179 U.S.A.



SAFETY RULES



Safe Operation Practices for Ride-On Mowers

IMPORTANT: THIS CUTTING MACHINE IS CAPABLE OF AMPUTATING HANDS AND FEET AND THROWING OBJECTS FAILURE TO OBSERVE THE FOLLOWING SAFETY INSTRUCTIONS COULD RESULT IN SERIOUS INJURY OR DEATH

I. GENERAL OPERATION

- Read, understand, and follow all instructions in the manual and on the machine before starting.
- Only allow responsible adults, who are familiar with the instructions, to operate the machine.
- Clear the area of objects such as rocks, toys, wire, etc., which could be picked up and thrown by the blade.
- Be sure the area is clear of other people before mowing. Stop machine if anyone enters the area.
- Never carry passengers.
- Do not mow in reverse unless absolutely necessary. Always look down and behind before and while backing.
- Be aware of the mower discharge direction and do not point it at anyone. Do not operate the mower without either the entire grass catcher or the guard in place.
- Slow down before turning.
- Never leave a running machine unattended. Always turn off blades, set parking brake, stop engine, and remove keys before dismounting.
- Turn off blades when not mowing.
- Stop engine before removing grass catcher or unclogging chute.
- Mow only in daylight or good artificial light.
- Do not operate the machine while under the influence of alcohol or drugs.
- Watch for traffic when operating near or crossing roadways.
- Use extra care when loading or unloading the machine into a trailer or truck.

II. SLOPE OPERATION

Slopes are a major factor related to loss-of-control and tipover accidents, which can result in severe injury or death. All slopes require extra caution. If you cannot back up the slope or if you feel uneasy on it, do not mow it.

DO:

- Mow up and down slopes, not across.
- Remove obstacles such as rocks, tree limbs, etc.
- Watch for holes, ruts, or bumps. Uneven terrain could overturn the machine. *Tall grass can hide obstacles.*
- Use slow speed. Choose a low gear so that you will not have to stop or shift while on the slope.
- Follow the manufacturer's recommendations for wheel weights or counterweights to improve stability.
- Use extra care with grass catchers or other attachments. These can change the stability of the machine.
- Keep all movement on the slopes *slow* and *gradual*. Do not make sudden changes in speed or direction.
- Avoid starting or stopping on a slope. If tires lose traction, disengage the blades and proceed slowly *straight* down the slope.

DO NOT:

- *Do not* turn on slopes unless necessary, and then, turn slowly and gradually downhill, if possible.
- *Do not* mow near drop-offs, ditches, or embankments. The mower could suddenly turn over if a wheel is over the edge of a cliff or ditch, or if an edge caves in.
- *Do not* mow on wet grass. Reduced traction could cause sliding.
- *Do not* try to stabilize the machine by putting your foot on the ground.
- *Do not* use grass catcher on steep slopes.

III. CHILDREN

Tragic accidents can occur if the operator is not alert to the presence of children. Children are often attracted to the machine and the mowing activity. *Never* assume the children will remain where you last saw them.

- Keep children out of the mowing area and under the watchful care of another responsible adult.
- Be alert and turn machine off if children enter the area.
- Before and when backing, look behind and *down* for small children.
- Never carry children. They may fall off and be seriously injured or interfere with safe machine operation.
- Never allow children to operate the machine.
- Use extra care when approaching blind corners, shrubs, trees, or other objects that may obscure vision.

IV. SERVICE

- Use extra care in handling gasoline and other fuels. They are flammable and vapors are explosive.
 - Use only an approved container.
 - Never remove gas cap or add fuel with the engine running. Allow engine to cool before refueling. Do not smoke.
 - Never refuel the machine indoors.
 - Never store the machine or fuel container inside where there is an open flame, such as a water heater.
- Never run a machine inside a closed area.
- Keep nuts and bolts, especially blade attachment bolts, tight and keep equipment in good condition.
- Never tamper with safety devices. Check their proper operation regularly.
- Keep machine free of grass, leaves, or other debris build-up. Clean oil or fuel spillage. Allow machine to cool before storing.
- Stop and inspect the equipment if you strike an object. Repair, if necessary, before restarting.
- Never make adjustments or repairs with the engine running.
- Grass catcher components are subject to wear, damage, and deterioration, which could expose moving parts or allow objects to be thrown. Frequently check components and replace with manufacturer's recommended parts, when necessary.
- Mower blades are sharp and can cut. Wrap the blade(s) or wear gloves, and use extra caution when servicing them.
- Check brake operation frequently. Adjust and service as required.



Look for this symbol to point out important safety precautions. It means **CAUTION!!! BECOME ALERT!!! YOUR SAFETY IS INVOLVED.**



CAUTION: Always disconnect spark plug wire and place wire where it cannot contact spark plug in order to prevent accidental starting when setting up, transporting, adjusting or making repairs.



WARNING

The engine exhaust from this product contains chemicals known to the State of California to cause cancer, birth defects, or other reproductive harm.

CONGRATULATIONS on your purchase of a Sears tractor. It has been designed, engineered and manufactured to give you the best possible dependability and performance.

Should you experience any problem you cannot easily remedy, please contact your nearest Sears Service Center/Department. We have competent, well-trained technicians and the proper tools to service or repair this tractor.

Please read and retain this manual. The instructions will enable you to assemble and maintain your tractor properly. Always observe the "SAFETY RULES".

MODEL NUMBER	917.256611
SERIAL NUMBER	_____
DATE OF PURCHASE	_____
THE MODEL AND SERIAL NUMBERS WILL BE FOUND ON A PLATE UNDER THE SEAT.	
YOU SHOULD RECORD BOTH SERIAL NUMBER AND DATE OF PURCHASE AND KEEP IN A SAFE PLACE FOR FUTURE REFERENCE.	

MAINTENANCE AGREEMENT

A Sears maintenance agreement is available on this product. Contact your nearest Sears store for details.

CUSTOMER RESPONSIBILITIES

- Read and observe the safety rules.
- Follow a regular schedule in maintaining, caring for and using your tractor.
- Follow the instructions under "Customer Responsibilities" and "Storage" sections of this owner's manual.

PRODUCT SPECIFICATIONS

HORSEPOWER:	15.5
GASOLINE CAPACITY AND TYPE:	3.5 GALLONS UNLEADED REGULAR
OIL TYPE (API-SF/SG):	SAE 10W-30 (above 32°F) SAE 5W-30 (below 32°F)
OIL CAPACITY:	W/ FILTER: 4.0 PINTS W/O FILTER: 3.5 PINTS
SPARK PLUG: (GAP: .040")	CHAMPION RC12YC
VALVE CLEARANCE:	NOT ADJUSTABLE
GROUND SPEED (MPH):	FORWARD: 5.5 REVERSE: 2.4
TIRE PRESSURE:	FRONT: 14 PSI REAR: 10 PSI
CHARGING SYSTEM:	3 AMPS BATTERY 5 AMPS HEADLIGHTS
BATTERY:	AMP/HR: 30 MIN. CCA: 240 CASE SIZE: U1R
BLADE BOLT TORQUE:	30-35 FT. LBS.

WARNING: This tractor is equipped with an internal combustion engine and should not be used on or near any unimproved forest-covered, brush-covered or grass-covered land unless the engine's exhaust system is equipped with a spark arrester meeting applicable local or state laws (if any). If a spark arrester is used, it should be maintained in effective working order by the operator.

In the state of California the above is required by law (Section 4442 of the California Public Resources Code). Other states may have similar laws. Federal laws apply on federal lands. A spark arrester for the muffler is available through your nearest Sears Authorized Service Center (See REPAIR PARTS section of this manual).

LIMITED TWO YEAR WARRANTY ON CRAFTSMAN RIDING EQUIPMENT

For two (2) years from the date of purchase, if this Craftsman Riding Equipment is maintained, lubricated and tuned up according to the instructions in the owner's manual, Sears will repair or replace, free of charge, any parts found to be defective in material or workmanship.

This Warranty does not cover:

- Expendable items which become worn during normal use, such as blades, spark plugs, air cleaners, belts, etc.
- Tire replacement or repair caused by punctures from outside objects, such as nails, thorns, stumps, or glass.
- Repairs necessary because of operator abuse, negligence, improper storage or accident or the failure to maintain the equipment according to the instructions contained in the owner's manual.
- Riding equipment used for commercial or rental purposes.

LIMITED 90 DAY WARRANTY ON BATTERY

For ninety (90) days from date of purchase, if any battery included with this riding equipment proves defective in material or workmanship and our testing determines the battery will not hold a charge, Sears will replace the battery at no charge.

IN-HOME WARRANTY SERVICE ON YOUR CRAFTSMAN RIDING EQUIPMENT IS AVAILABLE AT NO-CHARGE FOR 30 DAYS FROM THE DATE OF PURCHASE. PLEASE CONTACT YOUR NEAREST SERVICE CENTER. AFTER 30 DAYS FROM THE DATE OF PURCHASE, WARRANTY SERVICE IS AVAILABLE BY TAKING YOUR CRAFTSMAN RIDING EQUIPMENT TO YOUR NEAREST SEARS SERVICE CENTER. (IN-HOME WARRANTY SERVICE WILL STILL BE AVAILABLE AFTER 30 DAYS FROM THE DATE OF PURCHASE BUT A STANDARD TRIP CHARGE WILL APPLY.) THIS WARRANTY APPLIES ONLY WHILE THIS PRODUCT IS IN THE UNITED STATES.

This Warranty gives you specific legal rights, and you may also have other rights which may vary from state to state.

SEARS, ROEBUCK AND CO., D/817 WA, HOFFMAN ESTATES, IL 60179

TABLE OF CONTENTS

SAFETY RULES	2	MAINTENANCE SCHEDULE	17
PRODUCT SPECIFICATIONS	3	SERVICE AND ADJUSTMENTS	21-27
CUSTOMER RESPONSIBILITIES	3, 16-19	STORAGE	28
WARRANTY	3	TROUBLESHOOTING	29-30
TRACTOR ACCESSORIES	5	REPAIR PARTS - TRACTOR	32-49
ASSEMBLY	7-10	REPAIR PARTS - ENGINE	50-55
OPERATION	11-16	PARTS ORDERING/SERVICE	BACK COVER



INDEX

A		Engine:	Operation	12-16
Accessories	5	Air Filter	Operating Mower	14
Adjustments:		Air Screen	Options:	
Brake	24	Cooling Fins	Accessories	5
Carburetor	27	Oil Change	Spark Arrester	3,40
Mower		Oil Level		
Front-To-Back	22	Oil Type		
Side-To-Side	22	Preparation		
Throttle Control Cable	27	Repair Parts		
Air Filter, Engine	20	Starting		
Air Screen, Engine	19	Storage		
Assembly	7-10			
B		F		
Battery:		Filter:		
Charging	8	Air Filter		
Cleaning	18	Fuel		
Starting with Weak Battery	26	Fuel:		
Storage	28	Type		
Terminals	18	Storage		
Belt:		Fuse		
Motion Drive				
Removal/Replacement	24	H		
Mower Belt(s)		Hood Removal/Installation		
Removal/Replacement	23			
Blade:		L		
Sharpening	18	Leveling Mower Deck		
Replacement	18	Lubrication:		
Brake Adjustment	24	Chart		
		Engine		
C		M		
Carburetor Adjustment	27	Maintenance Schedule		
Controls, Tractor	12	Mower:		
Customer Responsibilities	17-20	Adjustment, Front-to-Back		
Engine:		Adjustment, Side-to-Side		
Air Filter	20	Blade Replacement		
Air Screen	19	Blade Sharpening		
Cooling Fins	20	Cutting Height		
Engine Oil	15,19	Installation		
Fuel Filter	20	Operation		
Spark Plug(s)	20	Removal		
Tractor:		Mowing Tips		
Battery	18	Muffler		
Blade	18	Spark Arrester		
Lubrication Chart	17			
Maintenance Schedule	17	O		
Tire Care	8,18,25	Oil:		
Transaxle	19	Cold Weather Conditions		
Cutting Height, Mower	13	Engine		
		Storage		
E		P		
Electrical:		Parking Brake		
Interlocks and Relays	26	Parts Bag		
Schematic	31	Parts, Replacement/Repair		
Wiring Diagram	32	Product Specifications		
		R		
		Repair Parts		
		S		
		Safety Rules		
		Seat		
		Service and Adjustments		
		Carburetor		
		Fuse		
		Hood Removal/Installation		
		Motion Drive Belt		
		Removal/Replacement		
		Mower Belt(s)		
		Removal/Replacement		
		Mower Adjustment		
		Front-to-Back		
		Side-to-Side		
		Mower Removal/Installation		
		Tire Care		
		Slope Guide Sheet		
		Spark Plug(s)		
		Specifications		
		Starting the Engine		
		Steering Wheel		
		Stopping the Tractor		
		Storage		
		T		
		Throttle Control Cable Adjustment		
		Tires		
		Trouble Shooting Chart		
		Transaxle		
		W		
		Warranty		
		Wiring Diagram		
		Wiring Schematic		

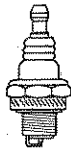

ACCESSORIES AND ATTACHMENTS

These accessories and attachments were available through most Sears retail outlets and service centers when the tractor was purchased. Most Sears stores can order these items for you when you provide the model number of your tractor.

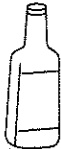
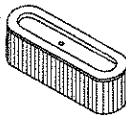
ENGINE

SPARK PLUG	GAS CAN	ENGINE OIL	FUEL STABILIZER	AIR FILTER
				

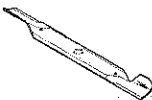
MAINTENANCE

BLADES	BELTS
	

PERFORMANCE

Sears offers a wide variety of attachments that fit your tractor. Many of these are listed below with brief explanations of how they can help you. This list was current at the time of publication; however, it may change in future years - more attachments may be added, changes may be made in these attachments, or some may no longer be available or fit your model. **Contact your nearest Sears store for the accessories and attachments that are available for your tractor.**

Most of these attachments do not require additional hitches or conversion kits (those that do are indicated) and are designed for easy attaching and detaching.

AERATOR promotes deep root growth for a healthy lawn. Tapered 2.5-inch steel spikes mounted on 10-inch diameter discs puncture holes in soil at close intervals to let moisture soak in. Steel weight tray for increased penetration.

BAGGER lets you collect grass clippings and leaves for a healthier, neater looking lawn. Two Permanex containers hold 30-gallon plastic bags.

BUMPER protects front end of tractor from damage.

CARTS make hauling easy. Variety of sizes available, plus accessories such as side panel kits, tool caddy, cart cover, protective mat and dolly.

CORING AERATOR takes small plugs out of soil to allow moisture and nutrients to reach grass roots. 36-inch swath. 24 hardened steel coring tips. 150 lb. capacity weight tray.

EASY OIL DRAIN VALVE makes oil changes easier, faster.

FRONT NOSE ROLLER canters in front of mower deck to reduce chances of "scalping" on uneven terrain.

GANG HITCH lets you tow 2 or 3 pull-behind attachments at once, such as sweepers, dethatchers, aerators (not for use with rollers, carts or other heavy attachments).

GAUGE WHEELS on both sides of the mower deck reduce chances of "scalping" on uneven terrain. For mower decks not so equipped.

MULCH RAKE/DETHATCHER loosens soil and flips thatch and matted leaves to lawn surface for easy pickup. Twenty spring tine teeth. Useful to prepare bare areas for seeding. Available for front or rear mounting. **HIGH PERFORMANCE REEL-ACTION SPRING TINE DETHATCHER** covers 36-inch wide path and tosses thatch into large hopper. Mounts behind tractor.

MULCHING CLOSE-OUT PLATE KIT, once installed, lets you mulch, discharge or bag clippings (bagger optional) without changing blades. For models not equipped as 3-in-1 Convertible mowers. See "MOWER" in the Repair Parts section of this manual.

RAMP TOPS AND FEET let you load and unload tractor from a pickup truck. Use with 2 x 8 or 2 x 10 lumber.

ROLLER for smoother lawn surface. 36-inch wide, 18-inch diameter water-tight drum holds up to 390 lbs. of weight. Rounded edges prevent harm to turf. Adjustable scraper automatically cleans drum.

SNOW BLADE for snow removal only. 14-inch high, 48-inch wide blade clears 42-inch path when angled left or right. Raises, lowers with side lever. Adjustable skids; replaceable, reversible scraper bar. (Use with tire chains and wheel weights and/or rear drawbar weight.)

SNOWTHROWER has 40-inch swath. Drum-type auger handles powdery and wet/heavy snow. Mounts easily with simple pin arrangement. Discharge chute adjusts from tractor seat. 6-inch diameter spout discharges snow 10 to 50 feet. Lift controlled at tractor seat. (Use with chains and wheel weights and/or rear drawbar weight.)

SPRAYERS use 12-volt DC electric motor that connects to the tractor battery or other 12-volt source. Includes booms for automatic spraying and hand held wand for spot spraying. Wand has adjustable spray pattern. For applying herbicides, insecticides, fungicides and liquid fertilizers.

SPREADER/SEEDERS make seeding, fertilizing, and weed killing easy. Broadcast spreaders are also useful for granular deicers and sand.

SWEEPERS let you collect grass clippings and leaves.

TILLER has 5 hp engine and 36-inch swath to prepare seed beds, cultivate and compost garden residue. Tiller has its own built-in lift and depth control system and does NOT require a sleeve hitch. Fits any lawn, yard or garden tractor. Simply hook up to the tractor drawbar and go! **Optional accessories** convert unit for dethatching, aerating, hilling...without tools.

TIRE CHAINS are heavy duty; closely spaced extra-large cross links give smooth ride, outstanding traction.

TRACTOR CAB has heavy duty vinyl fabric over tubular steel frame, ABS plastic top; clear plastic windshield offers 360 degree visibility. Hinged metal doors with catch. Keeps operator warm and dry. Remove vinyl sides and windshields for use as sun protector in summer. **Optional accessories include:** tinted/tempered solid safety glass windshield with hand operated wiper; 12-volt amber caution light for mounting on cab top.

VACS for powerful collection of heavy grass clippings and leaves. **Optional wand attachment** to pick up debris in hard-to-reach places. **VAC/CHIPPER** includes a chipper-shredder.

WEIGHT BRACKET for drawbar for snow removal applications. Uses (1) 55 lb. weight.

WHEEL WEIGHTS for rear wheels provide needed traction for snow removal or dozing heavy materials.

CONTENTS OF HARDWARE PACK

Parts Bag contents shown full size

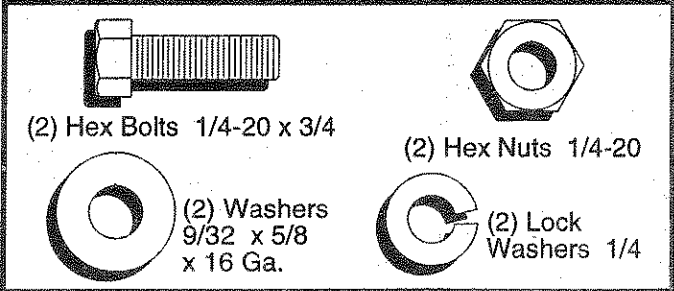
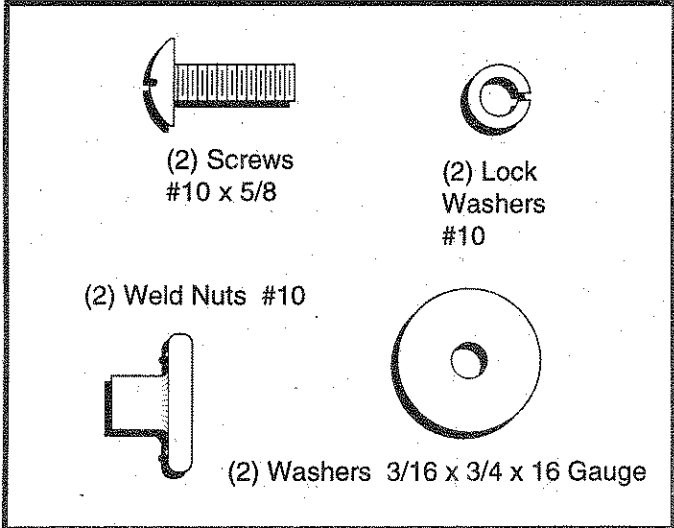
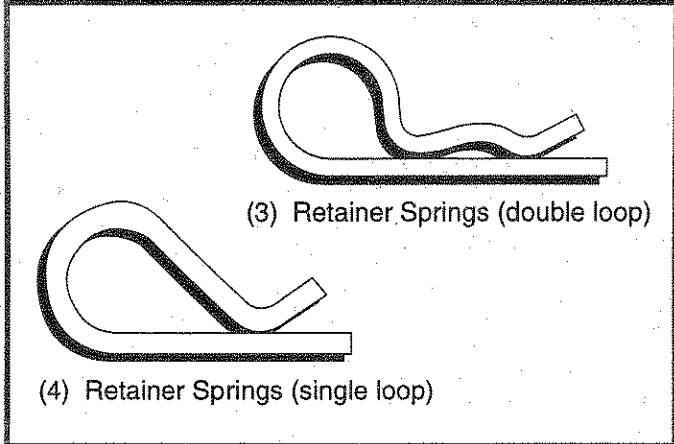
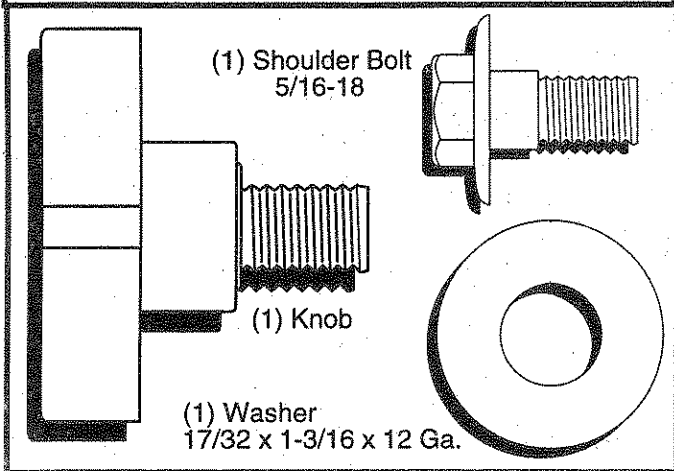

Parts packed separately in carton

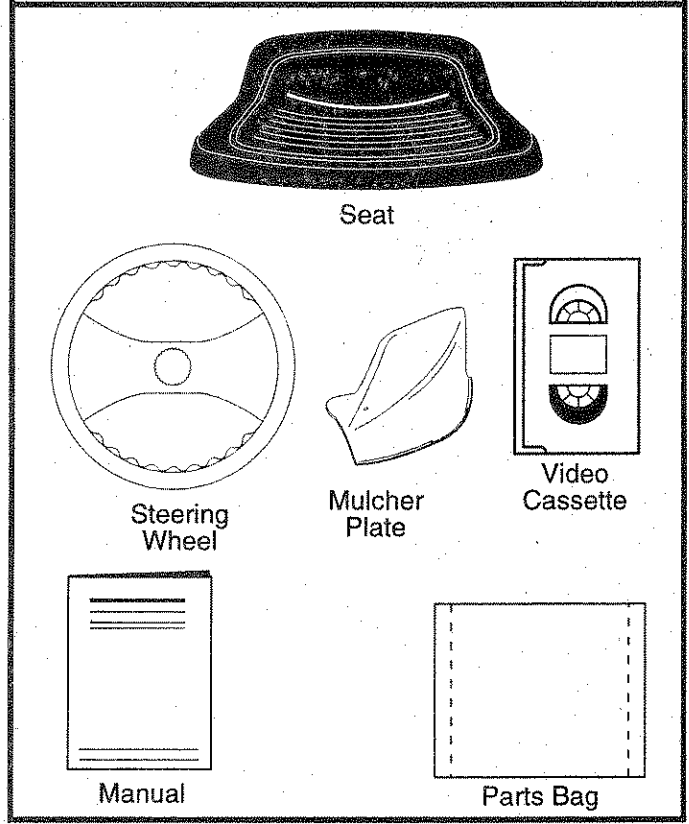

Parts bag contents not shown full size

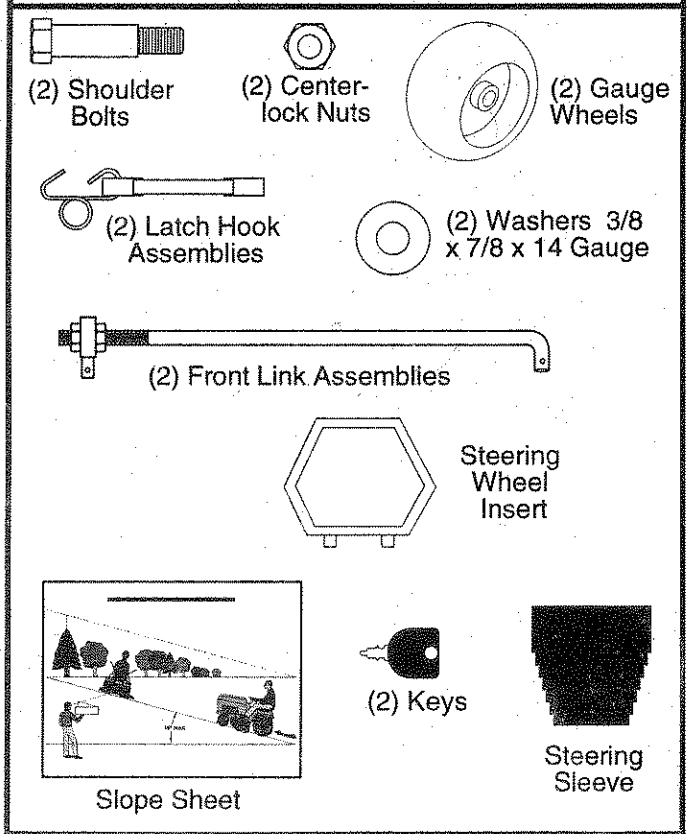

ASSEMBLY

Your new tractor has been assembled at the factory with exception of those parts left unassembled for shipping purposes. To ensure safe and proper operation of your tractor, all parts and hardware you assemble must be tightened securely. Use the correct tools as necessary to insure proper tightness.

TOOLS REQUIRED FOR ASSEMBLY

A socket wrench set will make assembly easier. Standard wrench sizes are listed.

- (1) 3/4" wrench
- (1) 9/16" wrench
- (1) 1/2" wrench
- (1) 3/4" socket w/drive ratchet
- (2) 7/16" wrench
- Utility knife
- Tire pressure gauge

When right and left hand is mentioned in this manual, it means when you are in the operating position (seated behind the steering wheel).

TO REMOVE TRACTOR FROM CARTON

UNPACK CARTON

- Remove all accessible loose parts and parts cartons from carton (See page 6).
- Cut, from top to bottom, along lines on all four corners of carton, and lay panels flat.
- Remove mower and packing materials.
- Check for any additional loose parts or cartons and remove.

BEFORE ROLLING TRACTOR OFF SKID

ATTACH STEERING WHEEL (See Fig. 1)

- Remove locknut and large flat washer from steering shaft.
- Position front wheels of the tractor so they are pointing straight forward.
- Slide the steering sleeve over the steering shaft.
- Position steering wheel so cross bars are horizontal (left to right) and slide onto adapter.
- Secure steering wheel to steering shaft with locknut and large flat washer previously removed. Tighten securely.
- Snap steering wheel insert into center of steering wheel.
- Remove protective plastic from tractor hood and grill.

IMPORTANT: CHECK FOR AND REMOVE ANY STAPLES IN SKID THAT MAY PUNCTURE TIRES WHERE TRACTOR IS TO ROLL OFF SKID.

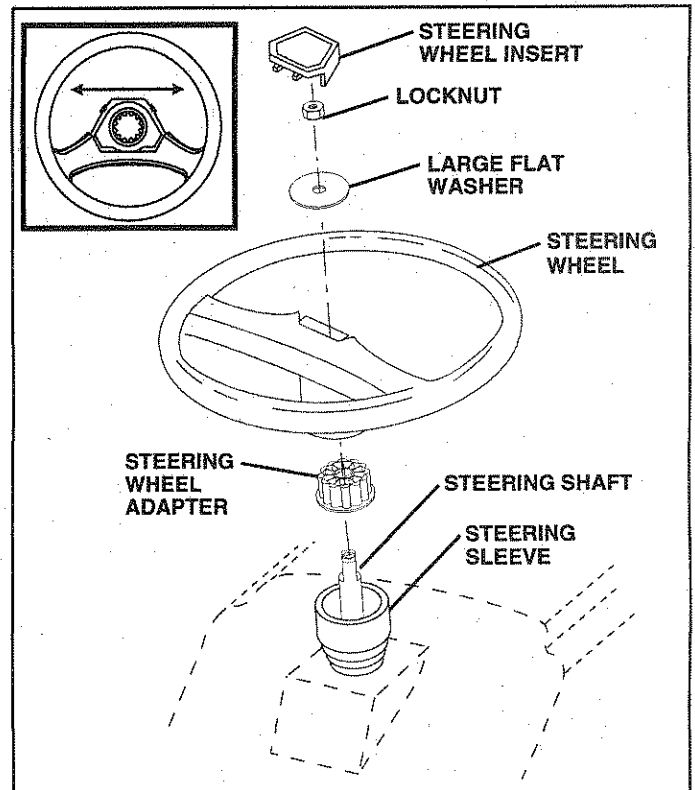

FIG. 1

TO ROLL TRACTOR OFF SKID (See Operation section for location and function of controls)

- Press lift lever plunger and raise attachment lift lever to its highest position.
- Release parking brake by depressing clutch/brake pedal.
- Place freewheel control in freewheeling position to disengage transmission (See "TO TRANSPORT" in the Operation section of this manual).
- Roll tractor backwards off skid.

ASSEMBLY

CONNECT BATTERY (See Fig. 2)



CAUTION: Do not short battery terminals. Before connecting battery, remove metal bracelets, wristwatch bands, rings, etc.

Positive terminal must be connected first to prevent sparking from accidental grounding.

- Lift hood to raised position.
- Open terminal access doors, remove terminal protective caps and discard.
- If this battery is put into service after month and year indicated on label (label located between terminals) charge battery for minimum of one hour at 6-10 amps.
- First connect RED battery cable to positive (+) battery terminal with hex bolt, flat washer, lock washer and hex nut as shown. Tighten securely.
- Connect BLACK grounding cable to negative (-) battery terminal with remaining hex bolt, flat washer, lock washer and hex nut. Tighten securely.
- Close terminal access doors.

Use terminal access doors for:

- Inspection for secure connections (to tighten hardware).
- Inspection for corrosion.
- Testing battery.
- Jumping (if required).
- Periodic charging.

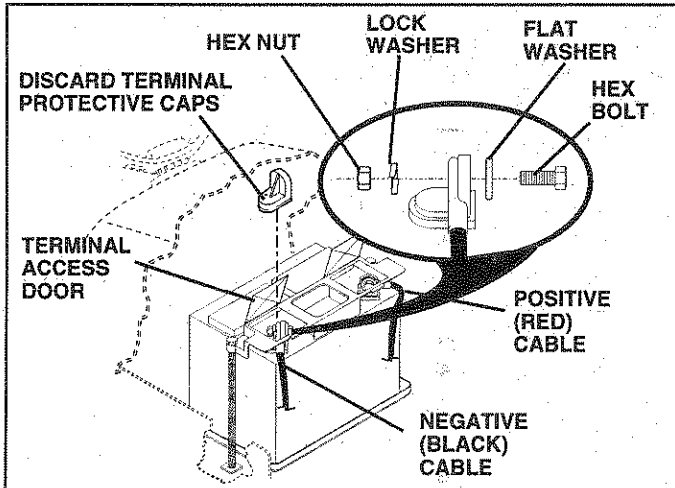

FIG. 2

INSTALL SEAT (See Fig. 3)

Adjust seat before tightening adjustment knob.

- Remove cardboard packing on seat pan.
- Place seat on seat pan and assemble shoulder bolt.
- Assemble adjustment knob and flat washer loosely. Do not tighten.
- Tighten shoulder bolt securely.
- Lower seat into operating position and sit on seat.
- Slide seat until a comfortable position is reached which allows you to press clutch/brake pedal all the way down.
- Get off seat without moving its adjusted position.
- Raise seat and tighten adjustment knob securely.

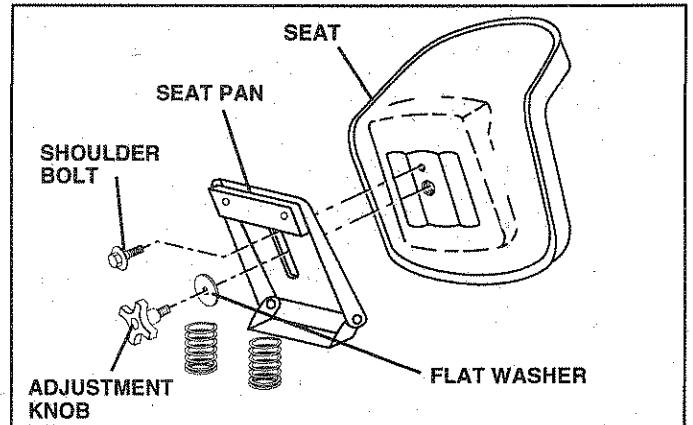

FIG. 3

CHECK TIRE PRESSURE

The tires on your tractor were overinflated at the factory for shipping purposes. Correct tire pressure is important for best cutting performance.

- Reduce tire pressure to PSI shown in "PRODUCT SPECIFICATIONS" on page 3 of this manual.

CHECK BRAKE SYSTEM

After you learn how to operate your tractor, check to see that the brake is properly adjusted. See "TO ADJUST BRAKE" in the Service and Adjustments section of this manual.

ASSEMBLY

INSTALL MOWER AND DRIVE BELT (See Figs. 4 and 7)

Be sure tractor is on level surface and mower suspension arms are raised with attachment lift control. Engage parking brake.

- Cut and remove ties securing anti-sway bar and belts. Swing anti-sway bar to left side of mower deck.
- Slide mower under tractor with discharge guard to right side of tractor.

IMPORTANT: CHECK BELT FOR PROPER ROUTING IN ALL MOWER PULLEY GROOVES. INSTALL BELT INTO ELECTRIC CLUTCH PULLEY GROOVE.

- Install one front link in top hole of the R.H. front mower bracket and R.H. front suspension bracket. Retain with two single loop retainer springs as shown.
- Install second front link in L.H. front suspension bracket only and retain with single loop retainer spring as shown.
- Turn height adjustment knob counterclockwise until it stops.
- Lower mower linkage with attachment lift control.
- Place the L.H. suspension arm on outward pointing deck pin. If necessary, rock and raise front of mower to align deck pin with the hole in suspension arm.
- Slide left side of mower back and install the unattached front link in top hole of the L.H. front mower bracket. Retain with single loop retainer spring as shown.

- Place the R.H. suspension arm on outward pointing deck pin. If necessary, rock and raise front of mower to align deck pin with the hole in suspension arm.
- Connect anti-sway bar to chassis bracket under left footrest and retain with double loop retainer spring.
- Retain both suspension arms to deck pins with double loop retainer springs.
- Turn height adjustment knob clockwise to remove slack from mower suspension.
- Raise mower to highest position.
- Assemble gauge wheels (See "TO ADJUST GAUGE WHEELS" in the Operation section of this manual).

CHECK MOWER LEVELNESS

For best cutting results, mower should be properly leveled. See "TO LEVEL MOWER HOUSING" in the Service and Adjustments section of this manual.

CHECK FOR PROPER POSITION OF ALL BELTS

See the figures that are shown for replacing motion, mower drive, and mower blade drive belts in the Service and Adjustments section of this manual. Verify that the belts are routed correctly.

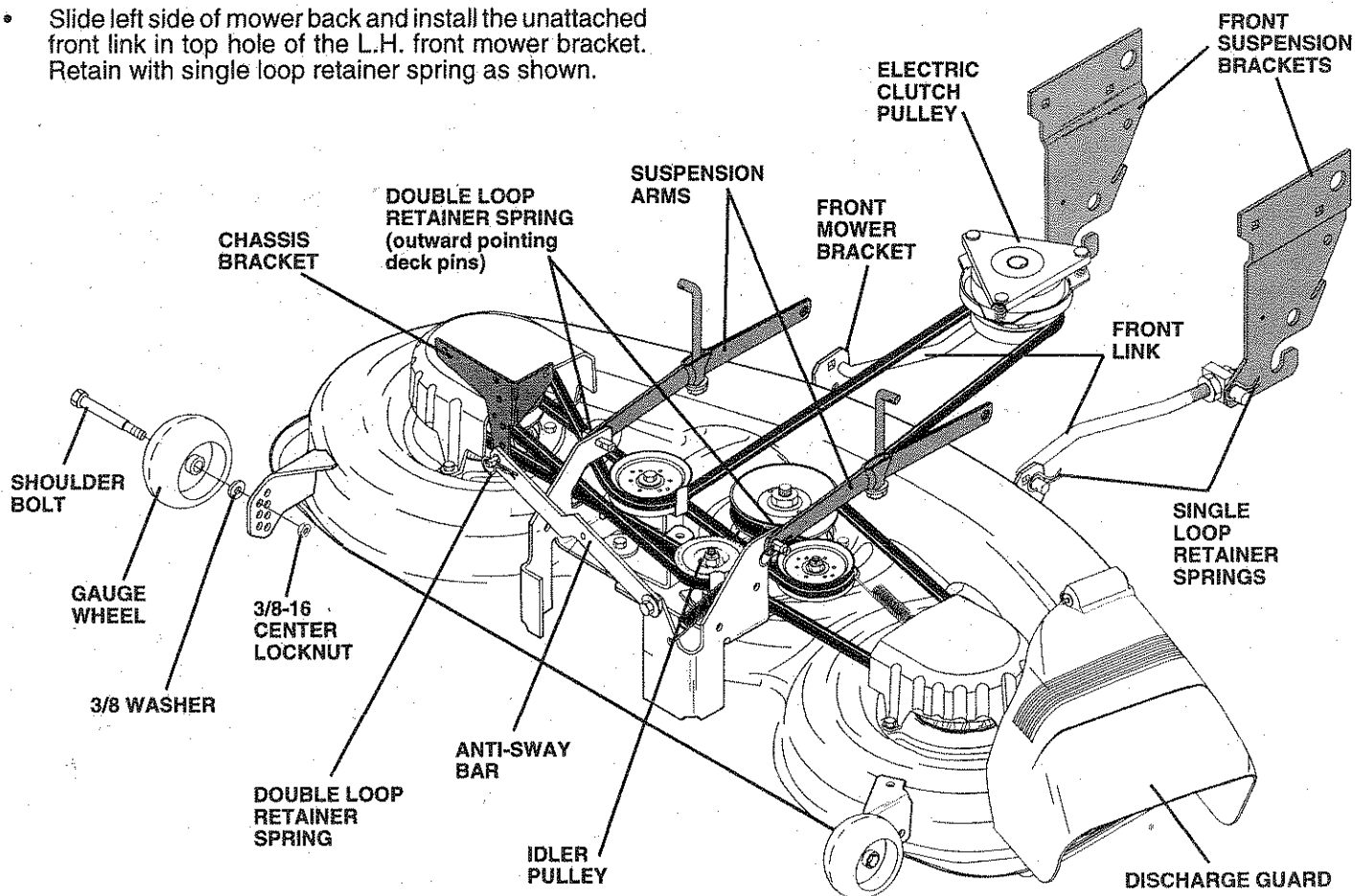

FIG. 4

ASSEMBLY

INSTALL MULCHER PLATE (See Figs. 5 and 6)

- Install two latch hooks to mulcher plate using screw, washer, lock washer, and weld nut as shown.

NOTE: Pre-assemble weld nut to latch hook by inserting weld nut from the top with hook pointing down.

- Tighten hardware securely.
- Raise and hold deflector shield in upright position.
- Place front of mulcher plate over front of mower deck opening and slide into place, as shown.
- Hook front latch into hole on front of mower deck.
- Hook rear latch into hole on back of mower deck.



CAUTION: Do not remove discharge guard from mower. Raise and hold guard when attaching mulcher plate and allow it to rest on plate while in operation.

TO CONVERT TO BAGGING OR DISCHARGING

Simply remove mulcher plate and store in a safe place. Your mower is now ready for discharging or installation of optional grass catcher accessory.

NOTE: It is not necessary to change blades. The mulcher blades are designed for discharging and bagging also.

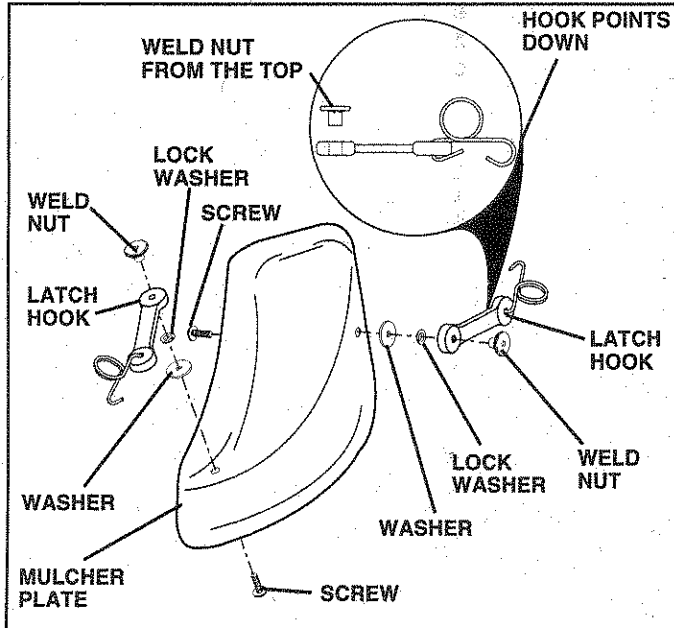

FIG. 5

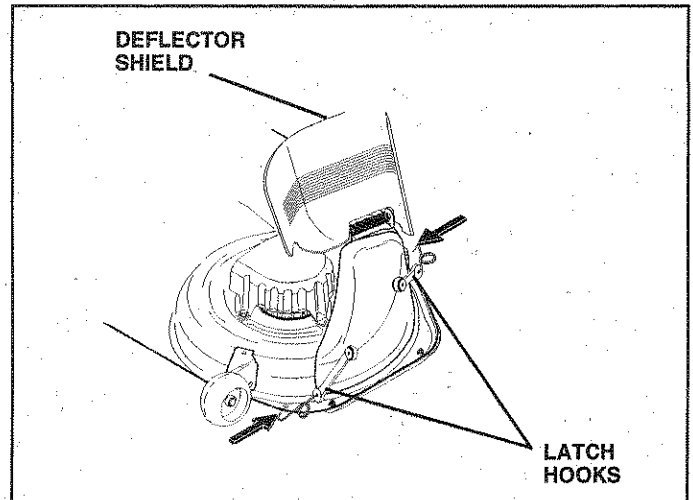

FIG. 6

✓ CHECKLIST

BEFORE YOU OPERATE AND ENJOY YOUR NEW TRACTOR, WE WISH TO ASSURE THAT YOU RECEIVE THE BEST PERFORMANCE AND SATISFACTION FROM THIS QUALITY PRODUCT.

PLEASE REVIEW THE FOLLOWING CHECKLIST:

- ✓ All assembly instructions have been completed.
- ✓ No remaining loose parts in carton.
- ✓ Battery is properly prepared and charged. (Minimum 1 hour at 6 amps).
- ✓ Seat is adjusted comfortably and tightened securely.
- ✓ All tires are properly inflated. (For shipping purposes, the tires were overinflated at the factory).
- ✓ Be sure mower deck is properly leveled side-to-side/ front-to-rear for best cutting results. (Tires must be properly inflated for leveling).
- ✓ Check mower and drive belts. Be sure they are routed properly around pulleys and inside all belt keepers.
- ✓ Check wiring. See that all connections are still secure and wires are properly clamped.
- ✓ Before driving tractor, be sure freewheel control is in drive position.

WHILE LEARNING HOW TO USE YOUR TRACTOR, PAY EXTRA ATTENTION TO THE FOLLOWING IMPORTANT ITEMS:

- ✓ Engine oil is at proper level.
- ✓ Fuel tank is filled with fresh, clean, regular unleaded gasoline.
- ✓ Become familiar with all controls - their location and function. Operate them before you start the engine.
- ✓ Be sure brake system is in safe operating condition.
- ✓ It is important to purge the transmission before you operate your new tractor for the first time. Follow proper starting and transmission purging instructions (See "TO START ENGINE" and "PURGE TRANSMISSION" in Operation section of this manual).

OPERATION

These symbols may appear on your tractor or in literature supplied with the product. Learn and understand their meaning.

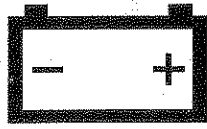

BATTERY

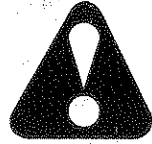

CAUTION OR WARNING



REVERSE



FORWARD



FAST



SLOW



ENGINE ON



ENGINE OFF



OIL PRESSURE



CLUTCH

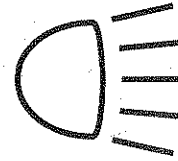

LIGHTS ON



LIGHTS OFF



FUEL



CHOKE



MOWER HEIGHT

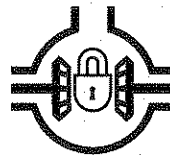

DIFFERENTIAL LOCK



PARKING BRAKE LOCKED



UNLOCKED



MOWER LIFT

R

REVERSE

N

NEUTRAL

H

HIGH

L

LOW

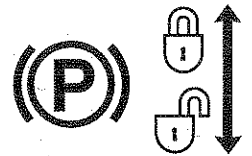

PARKING BRAKE



ATTACHMENT CLUTCH ENGAGED



ATTACHMENT CLUTCH DISENGAGED

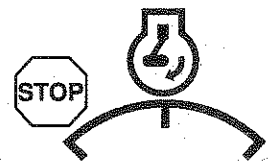

IGNITION



DANGER, KEEP HANDS AND FEET AWAY

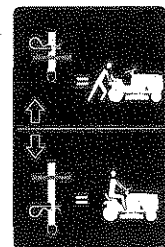
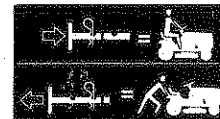

HYDROSTATIC FREE WHEEL
(Hydro Models only)

OPERATION

KNOW YOUR TRACTOR

READ THIS OWNER'S MANUAL AND SAFETY RULES BEFORE OPERATING YOUR TRACTOR

Compare the illustrations with your tractor to familiarize yourself with the locations of various controls and adjustments. Save this manual for future reference.

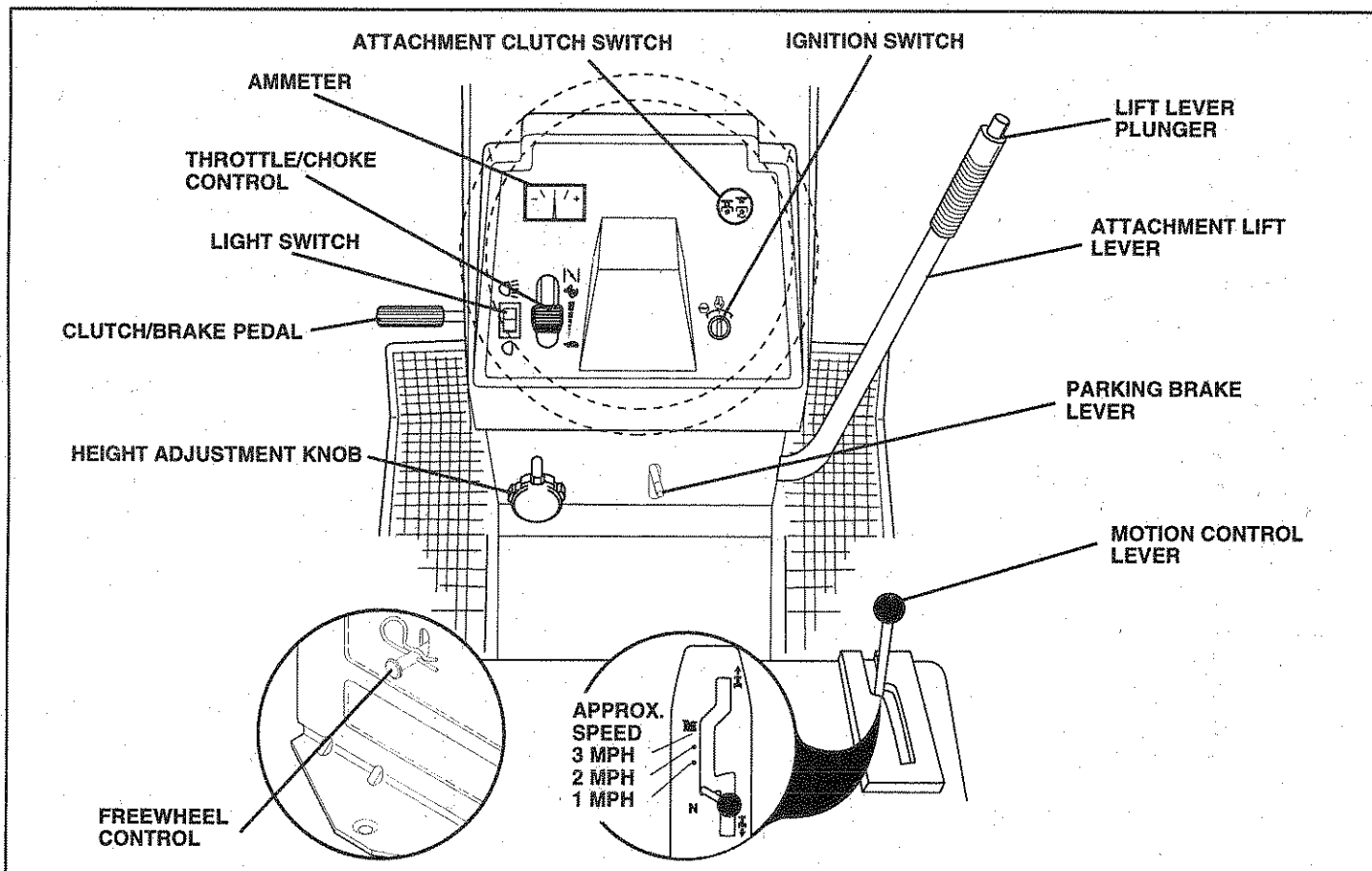

FIG. 7

Our tractors conform to the safety standards of the American National Standards Institute.

ATTACHMENT CLUTCH SWITCH: Used to engage the mower blades, or other attachments mounted to your tractor.

LIGHT SWITCH: Turns the headlights on and off.

THROTTLE/CHOKE CONTROL: Used for starting and controlling engine speed.

CLUTCH/BRAKE PEDAL: Used for declutching and braking the tractor and starting the engine.

PARKING BRAKE LEVER: Locks clutch/brake pedal into the brake position.

AMMETER - Indicates charging (+) or discharging (-) of battery.

HEIGHT ADJUSTMENT KNOB: Used to release attachment lift lever when changing its position.

MOTION CONTROL LEVER: Selects the speed and direction of tractor.

LIFT LEVER PLUNGER: Used to release attachment lift lever when changing its position.

ATTACHMENT LIFT LEVER: Used to raise and lower the mower deck or other attachments mounted to your tractor.

IGNITION SWITCH: Used for starting and stopping the engine.

FREEWHEEL CONTROL: Disengages transmission for pushing or slowly towing the tractor with the engine off.

OPERATION



The operation of any tractor can result in foreign objects thrown into the eyes, which can result in severe eye damage. Always wear safety glasses or eye shields while operating your tractor or performing any adjustments or repairs. We recommend a wide vision safety mask over the spectacles or standard safety glasses.

HOW TO USE YOUR TRACTOR TO SET PARKING BRAKE (See Fig. 8)

Your tractor is equipped with an operator presence sensing switch. When engine is running, any attempt by the operator to leave the seat without first setting the parking brake will shut off the engine.

- Depress clutch/brake pedal into full "BRAKE" position and hold.
- Place parking brake lever in "ENGAGED" position and release pressure from clutch/brake pedal. Pedal should remain in "BRAKE" position. Make sure parking brake will hold tractor secure.

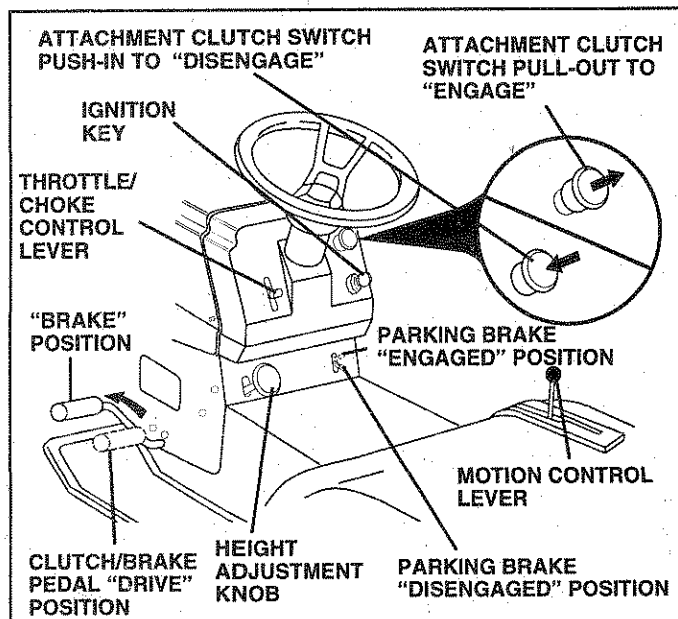

FIG. 8

STOPPING (See Fig. 8)

MOWER BLADES -

- Move attachment clutch switch to "DISENGAGED" position.

GROUND DRIVE -

- Depress clutch/brake pedal into full "BRAKE" position.
- Move motion control lever to neutral (N) position.

IMPORTANT: THE MOTION CONTROL LEVER DOES NOT RETURN TO NEUTRAL (N) POSITION WHEN THE CLUTCH/BRAKE PEDAL IS DEPRESSED.

ENGINE -

- Move throttle control to slow (🐢) position.

NOTE: Failure to move throttle control to slow (🐢) position and allowing engine to idle before stopping may cause engine to "backfire".

- Turn ignition key to "OFF" position and remove key. Always remove key when leaving tractor to prevent unauthorized use.
- Never use choke to stop engine.

NOTE: Under certain conditions when tractor is standing idle with the engine running, hot engine exhaust gases may cause "browning" of grass. To eliminate this possibility, always stop engine when stopping tractor on grass areas.



CAUTION: Always stop tractor completely, as described above, before leaving the operator's position; to empty grass catcher, etc.

TO USE THROTTLE CONTROL (See Fig. 8)

Always operate engine at full throttle.

- Operating engine at less than full throttle reduces the battery charging rate.
- Full throttle offers the best bagging and mower performance.

TO MOVE FORWARD AND BACKWARD (See Fig. 8)

The direction and speed of movement is controlled by the motion control lever.

- Start tractor with motion control lever in neutral (N) position.
- Release parking brake and clutch/brake pedal.
- Slowly move motion control lever to desired position.

TO ADJUST MOWER CUTTING HEIGHT (See Fig. 8)

The cutting height is controlled by turning the height adjustment knob in desired direction.

- Turn knob clockwise (↻) to raise cutting height.
- Turn knob counterclockwise (↺) to lower cutting height.

The cutting height range is approximately 1-1/2" to 4". The heights are measured from the ground to the blade tip with the engine not running. These heights are approximate and may vary depending upon soil conditions, height of grass and types of grass being mowed.

- The average lawn should be cut to approximately 2-1/2 inches during the cool season and to over 3 inches during hot months. For healthier and better looking lawns, mow often and after moderate growth.
- For best cutting performance, grass over 6 inches in height should be mowed twice. Make the first cut relatively high; the second to desired height.

OPERATION

TO ADJUST GAUGE WHEELS (See Fig. 9)

Adjust gauge wheels with tractor on a flat level surface.

- Adjust mower to desired cutting height (See "TO ADJUST MOWER CUTTING HEIGHT" in the Operation section of this manual).
- With mower in desired height of cut position, gauge wheels should be assembled so they are slightly off the ground. Install gauge wheel in appropriate hole with shoulder bolt, 3/8 washer, and 3/8-16 locknut and tighten securely.
- Repeat for opposite side installing gauge wheel in same adjustment hole.

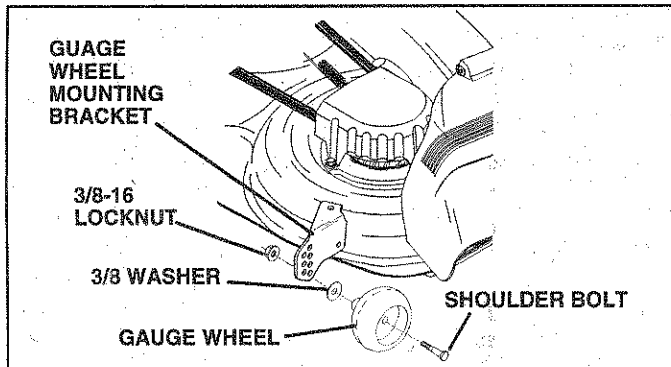

FIG. 9

TO OPERATE MOWER (See Fig. 10)

Your tractor is equipped with an operator presence sensing switch. Any attempt by the operator to leave the seat with the engine running and the attachment clutch engaged will shut off the engine.

- Select desired height of cut.
- Lower mower with attachment lift control.
- Start mower blades by engaging attachment clutch control.
- TO STOP MOWER BLADES - disengage attachment clutch control.

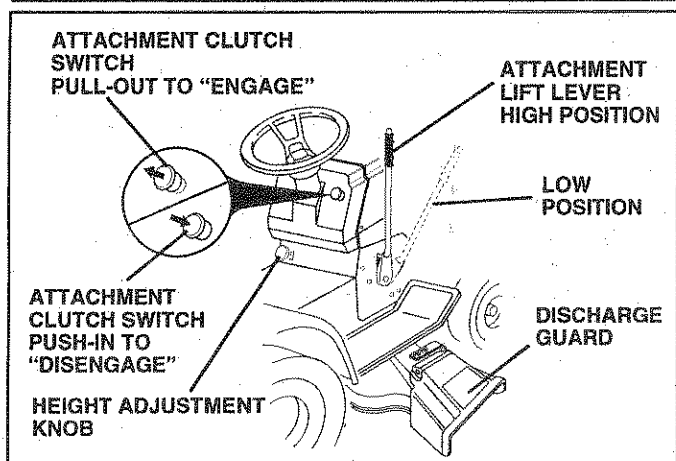
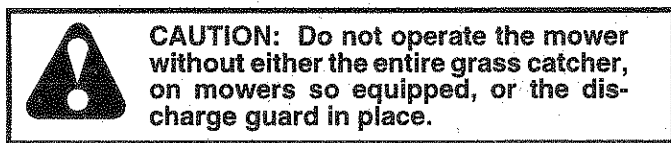

FIG. 10

TO OPERATE ON HILLS



CAUTION: Do not drive up or down hills with slopes greater than 15° and do not drive across any slope.

- Choose the slowest speed before starting up or down hills.
 - Avoid stopping or changing speed on hills.
 - If slowing is necessary, move throttle control lever to slower position.
 - If stopping is absolutely necessary, push clutch/brake pedal quickly to brake position and engage parking brake.
 - Move motion control lever to neutral (N) position.
- IMPORTANT:** THE MOTION CONTROL LEVER DOES NOT RETURN TO NEUTRAL (N) POSITION WHEN THE CLUTCH/BRAKE PEDAL IS DEPRESSED.
- To restart movement, slowly release parking brake and clutch/brake pedal.
 - Slowly move motion control lever to slowest setting.
 - Make all turns slowly.

TO TRANSPORT (See Figs. 7 and 11)

When pushing or towing your tractor, be sure to disengage transmission by placing freewheel control in freewheeling position. Free wheel control is located at the rear drawbar of tractor.

- Raise attachment lift to highest position with attachment lift control.
- Pull freewheel control knob out and hold in position by inserting retainer spring into forward hole of control rod.
- Do not push or tow tractor at more than two (2) MPH.
- To reengage transmission, reverse above procedure.

NOTE: To protect hood from damage when transporting your tractor on a truck or a trailer, be sure hood is closed and secured to tractor. Use an appropriate means of tying hood to tractor (rope, cord, etc.).

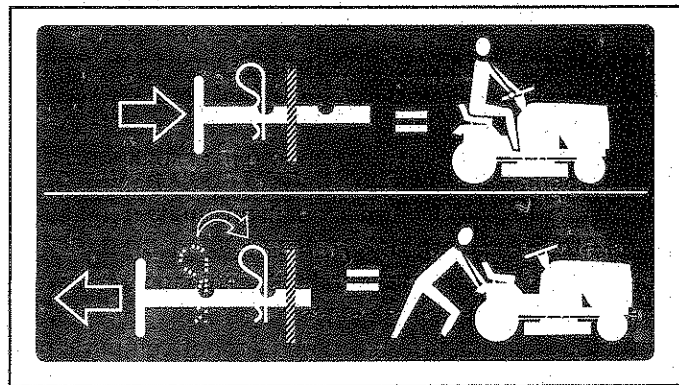

FIG. 11

OPERATION

BEFORE STARTING THE ENGINE CHECK ENGINE OIL LEVEL (See Fig. 16)

- The engine in your tractor has been shipped, from the factory, already filled with summer weight oil.
- Check engine oil with tractor on level ground.
- Unthread and remove oil fill cap/dipstick; wipe oil off. Reinsert the dipstick into the tube and rest oil fill cap on the tube. Do not thread the cap onto the tube. Remove and read oil level. If necessary, add oil until "FULL" mark on dipstick is reached. Do not overfill.
- For cold weather operation you should change oil for easier starting (See "OIL VISCOSITY CHART" in the Customer Responsibilities section of this manual).
- To change engine oil, see the Customer Responsibilities section in this manual.

ADD GASOLINE

- Fill fuel tank. Use fresh, clean, regular unleaded gasoline with a minimum of 87 octane. (Use of leaded gasoline will increase carbon and lead oxide deposits and reduce valve life). Do not mix oil with gasoline. Purchase fuel in quantities that can be used within 30 days to assure fuel freshness.

IMPORTANT: WHEN OPERATING IN TEMPERATURES BELOW 32°F (0°C), USE FRESH, CLEAN WINTER GRADE GASOLINE TO HELP INSURE GOOD COLD WEATHER STARTING.

WARNING: Experience indicates that alcohol blended fuels (called gasohol or using ethanol or methanol) can attract moisture which leads to separation and formation of acids during storage. Acidic gas can damage the fuel system of an engine while in storage. To avoid engine problems, the fuel system should be emptied before storage of 30 days or longer. Drain the gas tank, start the engine and let it run until the fuel lines and carburetor are empty. Use fresh fuel next season. See Storage Instructions for additional information. Never use engine or carburetor cleaner products in the fuel tank or permanent damage may occur.



CAUTION: Fill to bottom of gas tank filler neck. Do not overfill. Wipe off any spilled oil or fuel. Do not store, spill or use gasoline near an open flame.

TO START ENGINE (See Fig. 8)

When starting engine for the first time or if engine has run out of fuel, it will take extra cranking time to move fuel from the tank to the engine.

- Depress clutch/brake pedal and set parking brake.
- Place motion control lever in neutral (N) position.
- Move attachment clutch to "DISENGAGED" position.
- Move throttle control lever to choke (| \ |) position for cold engine start. For warm engine start, move throttle control to fast (↻) position.

- Insert key into ignition and turn key clockwise to "START" position and release key as soon as engine starts. Do not run starter continuously for more than fifteen seconds per minute. If engine does not start after several attempts, move throttle control to fast (↻) position, wait a few minutes and try again.
- When engine starts, slowly move throttle control lever to desired running speed.
- Allow engine to warm up for a few minutes before engaging drive or attachments.

IMPORTANT: COLD STARTING FOR HYDRO (BELOW 40°F) - AFTER STARTING ENGINE AND BEFORE DRIVING, LET TRANSMISSION WARM UP FOR ONE (1) MINUTE BY PLACING MOTION CONTROL LEVER IN NEUTRAL (N) POSITION AND RELEASING CLUTCH/ BRAKE PEDAL.

NOTE: If at a high altitude (above 3000 feet) or in cold temperatures (below 32°F), the carburetor fuel mixture may need to be adjusted for best engine performance. See "TO ADJUST CARBURETOR" in the Service and Adjustments section of this manual.

PURGE TRANSMISSION



CAUTION: Never engage or disengage freewheel lever while the engine is running.

To ensure proper operation and performance, it is recommended that the transmission be purged before operating tractor for the first time. This procedure will remove any trapped air inside the transmission which may have developed during shipping of your tractor.

IMPORTANT: SHOULD YOUR TRANSMISSION REQUIRE REMOVAL FOR SERVICE OR REPLACEMENT, IT SHOULD BE PURGED AFTER REINSTALLATION BEFORE OPERATING THE TRACTOR.

- Place tractor safely on level surface with engine off and parking brake set.
- Disengage transmission by placing freewheel control in freewheeling position (See "TO TRANSPORT" in this section of manual).
- Sitting in the tractor seat, start engine. After the engine is running, move throttle control to slow (↻) position. With motion control lever in neutral (N) position, slowly disengage clutch/brake pedal.
- Move motion control lever to full forward position and hold for five (5) seconds. Move lever to full reverse position and hold for five (5) seconds. Repeat this procedure three (3) times.

NOTE: During this procedure there will be no movement of drive wheels. The air is being removed from hydraulic drive system.

- Move motion control lever to neutral (N) position. Shut-off engine and set parking brake.

OPERATION

- Engage transmission by placing freewheel control in driving position (See "TO TRANSPORT" in this section of manual).
- Sitting in the tractor seat, start engine. After the engine is running, move throttle control to half (1/2) speed. With motion control lever in neutral (N) position, slowly disengage clutch/brake pedal.
- Slowly move motion control lever forward, after the tractor moves approximately five (5) feet, slowly move motion control lever to reverse position. After the tractor moves approximately five (5) feet return the motion control lever to the neutral (N) position. Repeat this procedure with the motion control lever three (3) times.
- Your tractor is now purged and now ready for normal operation.

MOWING TIPS

- Tire chains cannot be used when the mower housing is attached to tractor.
- Mower should be properly leveled for best mowing performance. See "TO LEVEL MOWER HOUSING" in the Service and Adjustments section of this manual.
- The left hand side of mower should be used for trimming.
- Drive so that clippings are discharged onto the area that has been cut. Have the cut area to the right of the machine. This will result in a more even distribution of clippings and more uniform cutting.
- When mowing large areas, start by turning to the right so that clippings will discharge away from shrubs, fences, driveways, etc. After one or two rounds, mow in the opposite direction making left hand turns until finished (See Fig. 12).
- If grass is extremely tall, it should be mowed twice to reduce load and possible fire hazard from dried clippings. Make first cut relatively high; the second to the desired height.
- Do not mow grass when it is wet. Wet grass will plug mower and leave undesirable clumps. Allow grass to dry before mowing.
- Always operate engine at full throttle when mowing to assure better mowing performance and proper discharge of material. Regulate ground speed by selecting a low enough gear to give the mower cutting performance as well as the quality of cut desired.
- When operating attachments, select a ground speed that will suit the terrain and give best performance of the attachment being used.

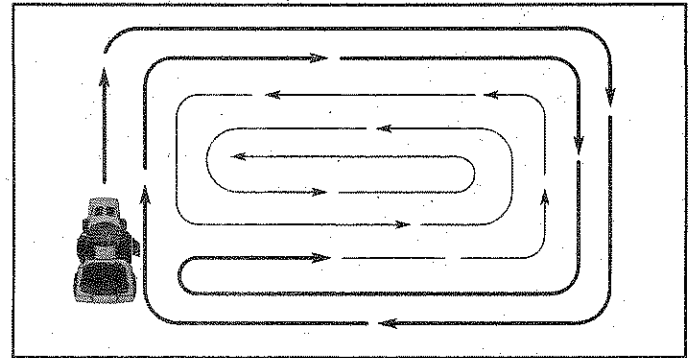

FIG. 12

MULCHING MOWING TIPS

IMPORTANT: FOR BEST PERFORMANCE, KEEP MOWER HOUSING FREE OF BUILT-UP GRASS AND TRASH. CLEAN AFTER EACH USE.

- The special mulching blade will recut the grass clippings many times and reduce them in size so that as they fall onto the lawn they will disperse into the grass and not be noticed. Also, the mulched grass will biodegrade quickly to provide nutrients for the lawn. Always mulch with your highest engine (blade) speed as this will provide the best recutting action of the blades.
- Avoid cutting your lawn when it is wet. Wet grass tends to form clumps and interferes with the mulching action. The best time to mow your lawn is the early afternoon. At this time the grass has dried and the newly cut area will not be exposed to the direct sun.
- For best results, adjust the mower cutting height so that the mower cuts off only the top one-third of the grass blades (See Fig. 13). For extremely heavy mulching, reduce your width of cut on each pass and mow slowly.
- Certain types of grass and grass conditions may require that an area be mulched a second time to completely hide the clippings. When doing a second cut, mow across or perpendicular to the first cut path.
- Change your cutting pattern from week to week. Mow north to south one week then change to east to west the next week. This will help prevent matting and graining of the lawn.

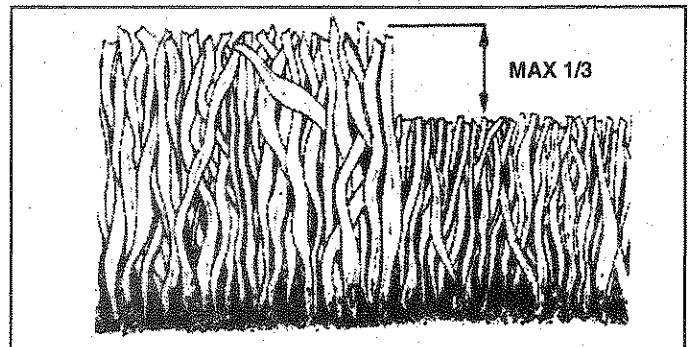

FIG. 13

CUSTOMER RESPONSIBILITIES

MAINTENANCE SCHEDULE FILL IN DATES AS YOU COMPLETE REGULAR SERVICE		BEFORE EACH USE							SERVICE DATES					
		BEFORE EACH USE	FIRST 2 HOURS	EVERY 8 HOURS	EVERY 25 HOURS	EVERY 50 HOURS	EVERY 100 HOURS	EVERY SEASON	BEFORE STORAGE					
TRACTOR	Check Brake Operation	✓		✓										
	Check Tire Pressure	✓		✓										
	Check for Loose Fasteners	✓					✓ ₇		✓					
	Sharpen/Replace Mower Blades				✓ ₄									
	Lubrication Chart				✓				✓					
	Check Battery Level/Recharge				✓ ₆									
	Clean Battery and Terminals				✓				✓					
	Check Transaxle Cooling				✓									
	Adjust Blade Belt(s) Tension							✓ ₅						
	Adjust Motion Drive Belt(s) Tension							✓ ₅						
	ENGINE	Check Engine Oil Level	✓		✓									
Change Engine Oil			✓		✓ _{1,2,3}				✓					
Clean Air Filter					✓ ₂									
Clean Air Screen					✓ ₂									
Inspect Muffler/Spark Arrester							✓							
Replace Oil Filter (If equipped)								✓ _{1,2}						
Clean Engine Cooling Fins								✓ ₂						
Replace Spark Plug								✓	✓					
Replace Air Filter Paper Cartridge								✓ ₂						
Replace Fuel Filter									✓					

1 - Change more often when operating under a heavy load or in high ambient temperatures.

2 - Service more often when operating in dirty or dusty conditions.

3 - If equipped with oil filter, change oil every 50 hours.

4 - Replace blades more often when mowing in sandy soil.

5 - If equipped with adjustable system.

6 - Not required if equipped with maintenance-free battery.

7 - Tighten front axle pivot bolt to 35 ft.-lbs. maximum.

Do not overtighten.

GENERAL RECOMMENDATIONS

The warranty on this tractor does not cover items that have been subjected to operator abuse or negligence. To receive full value from the warranty, operator must maintain tractor as instructed in this manual.

Some adjustments will need to be made periodically to properly maintain your tractor.

All adjustments in the Service and Adjustments section of this manual should be checked at least once each season.

- Once a year you should replace the spark plug, clean or replace air filter, and check blades and belts for wear. A new spark plug and clean air filter assure proper air-fuel mixture and help your engine run better and last longer.

BEFORE EACH USE

- Check engine oil level.
- Check brake operation.
- Check tire pressure.
- Check for loose fasteners.

LUBRICATION CHART

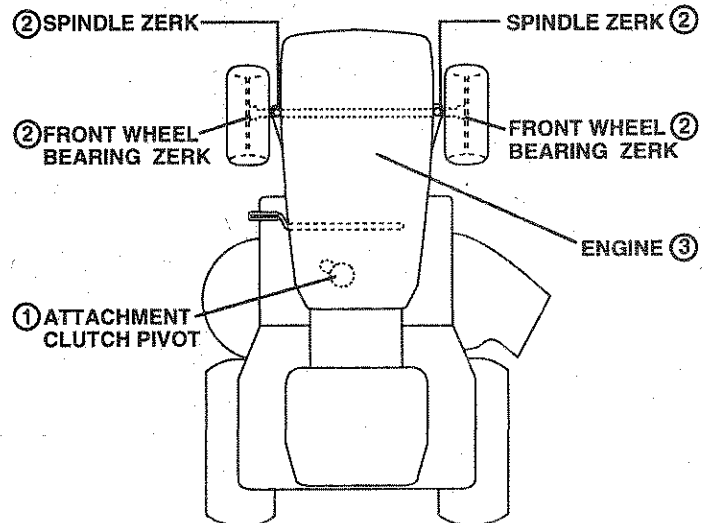

① SAE 30 MOTOR OIL

② GENERAL PURPOSE GREASE

③ REFER TO CUSTOMER RESPONSIBILITIES "ENGINE" SECTION

IMPORTANT: DO NOT OIL OR GREASE THE PIVOT POINTS, WHICH HAVE SPECIAL NYLON BEARINGS. VISCOUS LUBRICANTS WILL ATTRACT DUST AND DIRT THAT WILL SHORTEN THE LIFE OF THE SELF-LUBRICATING BEARINGS. IF YOU FEEL THEY MUST BE LUBRICATED, USE ONLY A DRY, POWDERED GRAPHITE TYPE LUBRICANT SPARINGLY.

CUSTOMER RESPONSIBILITIES

TRACTOR

Always observe safety rules when performing any maintenance.

BRAKE OPERATION

If tractor requires more than six (6) feet stopping distance at high speed in highest gear, then brake must be adjusted. (See "TO ADJUST BRAKE" in the Service and Adjustments section of this manual).

TIRES

- Maintain proper air pressure in all tires (See "PRODUCT SPECIFICATIONS" on page 3 of this manual).
- Keep tires free of gasoline, oil, or insect control chemicals which can harm rubber.
- Avoid stumps, stones, deep ruts, sharp objects and other hazards that may cause tire damage.

BLADE CARE

For best results mower blades must be kept sharp. Replace bent or damaged blades.

BLADE REMOVAL (See Fig. 14)

- Raise mower to highest position to allow access to blades.
- Remove hex bolt, lock washer and flat washer securing blade.
- Install new or resharpened blade with trailing edge up towards deck as shown.
- Reassemble hex bolt, lock washer and flat washer in exact order as shown.
- Tighten bolt securely (30-35 Ft. Lbs. torque).

IMPORTANT: BLADE BOLT IS GRADE 8 HEAT TREATED.

NOTE: We do not recommend sharpening blade - but if you do, be sure the blade is balanced.

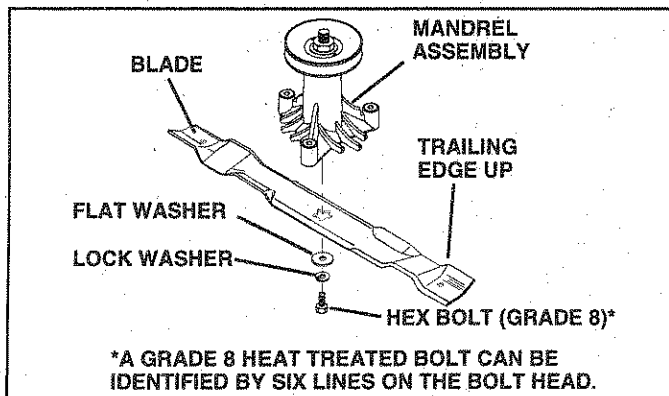

FIG. 14

TO SHARPEN BLADE (See Fig. 15)

Care should be taken to keep the blade balanced. An unbalanced blade will cause excessive vibration and eventual damage to mower and engine.

- The blade can be sharpened with a file or on a grinding wheel. Do not attempt to sharpen while on the mower.
- To check blade balance, you will need a 5/8" diameter steel bolt, pin, or a cone balancer. (When using a cone balancer, follow the instructions supplied with balancer).
- Slide blade on to an unthreaded portion of the steel bolt or pin and hold the bolt or pin parallel with the ground. If blade is balanced, it should remain in a horizontal position. If either end of the blade moves downward, sharpen the heavy end until the blade is balanced.

NOTE: Do not use a nail for balancing blade. The lobes of the center hole may appear to be centered, but are not.

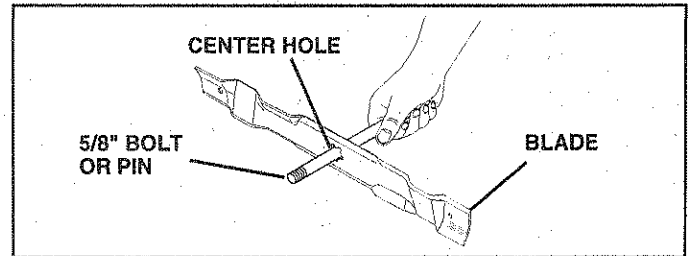

FIG. 15

BATTERY

Your tractor has a battery charging system which is sufficient for normal use. However, periodic charging of the battery with an automotive charger will extend its life.

- Keep battery and terminals clean.
- Keep battery bolts tight.
- Keep small vent holes open.
- Recharge at 6-10 amperes for 1 hour.

TO CLEAN BATTERY AND TERMINALS

Corrosion and dirt on the battery and terminals can cause the battery to "leak" power.

- Remove terminal guard.
- Disconnect BLACK battery cable first then RED battery cable and remove battery from tractor.
- Rinse the battery with plain water and dry.
- Clean terminals and battery cable ends with wire brush until bright.
- Coat terminals with grease or petroleum jelly.
- Reinstall battery (See "CONNECT BATTERY" in the Assembly section of this manual).

CUSTOMER RESPONSIBILITIES

TRANSAXLE COOLING

The fan and cooling fins of transmission should be kept clean to assure proper cooling.

Do not attempt to clean fan or transmission while engine is running or while the transmission is hot.

- Inspect cooling fan to be sure fan blades are intact and clean.
- Inspect cooling fins for dirt, grass clippings and other materials. To prevent damage to seals, do not use compressed air or high pressure sprayer to clean cooling fins.

TRANSAXLE PUMP FLUID

The transaxle was sealed at the factory and fluid maintenance is not required for the life of the transaxle. Should the transaxle ever leak or require servicing, contact your nearest authorized service center/department.

V-BELTS

Check V-belts for deterioration and wear after 100 hours of operation and replace if necessary. The belts are not adjustable. Replace belts if they begin to slip from wear.

ENGINE

LUBRICATION

Only use high quality detergent oil rated with API service classification SF or SG. Select the oil's SAE viscosity grade according to your expected operating temperature.

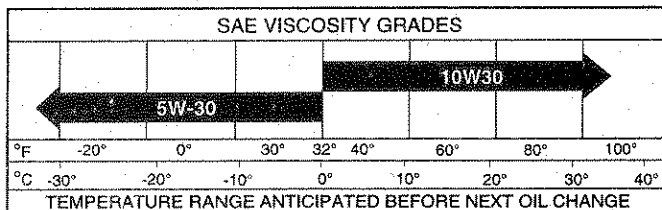

FIG. 16

NOTE: Although multi-viscosity oils (5W30, 10W30 etc.) improve starting in cold weather, these multi-viscosity oils will result in increased oil consumption when used above 32°F. Check your engine oil level more frequently to avoid possible engine damage from running low on oil.

Change the oil after the first two hours of operation and every 50 hours thereafter or at least once a year if the tractor is not used for 50 hours in one year.

Check the crankcase oil level before starting the engine and after each eight (8) hours of operation. Tighten oil fill cap/dipstick securely each time you check the oil level.

TO CHANGE ENGINE OIL (See Figs. 16 and 17)

Determine temperature range expected before oil change. All oil must meet API service classification SF or SG.

- Be sure tractor is on level surface.
- Oil will drain more freely when warm.
- Catch oil in a suitable container.
- Remove oil fill cap/dipstick. Be careful not to allow dirt to enter the engine when changing oil.
- Remove drain plug.
- After oil has drained completely, replace oil drain plug and tighten securely.
- Refill engine with oil through oil fill dipstick tube. Pour slowly. Do not overfill. For approximate capacity see "PRODUCT SPECIFICATIONS" on page 3 of this manual.
- Use gauge on oil fill cap/dipstick for checking level. Insert dipstick into the tube and rest the oil fill cap on the tube. Do not thread the cap onto the tube when taking reading. Keep oil at "FULL" line on dipstick. Tighten cap onto the tube securely when finished.

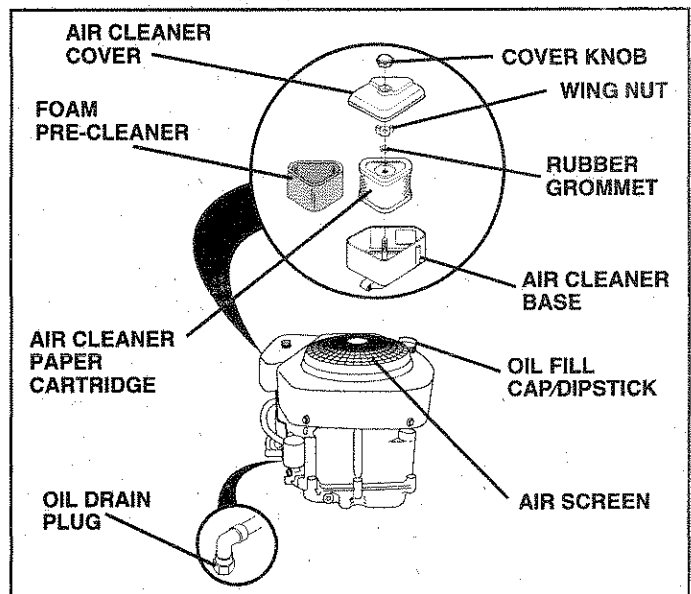

FIG. 17

CLEAN AIR SCREEN (See Fig. 17)

Air screen must be kept free of dirt and chaff to prevent engine damage from overheating. Clean with a wire brush or compressed air to remove dirt and stubborn dried gum fibers.

CUSTOMER RESPONSIBILITIES

AIR FILTER (See Fig. 17)

Your engine will not run properly using a dirty air filter. Clean the foam pre-cleaner after every 25 hours of operation or every season. Service paper cartridge every 100 hours of operation or every season, whichever occurs first.

Service air cleaner more often under dusty conditions.

- Remove knob and cover.
- Remove wing nut and air cleaner from base.

TO SERVICE PRE-CLEANER

- Slide foam pre-cleaner off cartridge.
- Wash it in liquid detergent and water.
- Squeeze it dry in a clean cloth.
- Saturate it in engine oil. Wrap it in clean, absorbent cloth and squeeze to remove excess oil.

TO SERVICE CARTRIDGE

- Gently tap the flat side of the paper cartridge to dislodge dirt. Do not wash the paper cartridge or use pressurized air, as this will damage the cartridge. Replace a dirty, bent, or damaged cartridge.
- Reinstall the pre-cleaner (cleaned and oiled) over the paper cartridge.
- Reassemble air cleaner, wing nut, cover and tighten knob securely.

CLEAN AIR INTAKE/COOLING AREAS

To insure proper cooling, make sure the grass screen, cooling fins, and other external surfaces of the engine are kept clean at all times.

Every 100 hours of operation (more often under extremely dusty, dirty conditions), remove the blower housing and other cooling shrouds. Clean the cooling fins and external surfaces as necessary. Make sure the cooling shrouds are reinstalled.

NOTE: Operating the engine with a blocked grass screen, dirty or plugged cooling fins, and/or cooling shrouds removed will cause engine damage due to overheating.

ENGINE OIL FILTER (See Fig. 18)

Replace the engine oil filter every season or every other oil change if the tractor is used more than 100 hours in one year.

- Drain oil from engine crankcase (See "TO CHANGE ENGINE OIL" in this section of this manual, through step remove drain plug).
- Remove oil filter and wipe off filter adapter.
- Apply a thin coating of new engine oil to the rubber gasket on replacement oil filter.
- Install replacement oil filter on filter adapter. Turn oil filter clockwise until rubber gasket contacts the filter adapter, then tighten filter an additional 1/2 turn.
- Fill crankcase with new oil (See "TO CHANGE ENGINE OIL" in this section of this manual). For approximate capacity see "PRODUCT SPECIFICATIONS" on page 3 of this manual.
- Start the engine and check for oil leaks. Correct any leaks before placing engine into full operation.

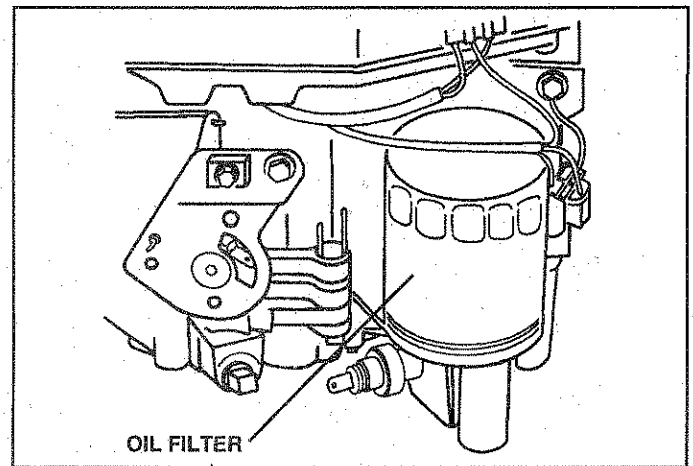

FIG. 18

MUFFLER

Inspect and replace corroded muffler and spark arrester (if equipped) as it could create a fire hazard and/or damage.

SPARK PLUGS

Replace spark plugs at the beginning of each mowing season or after every 100 hours of use, whichever comes first. Spark plug type and gap setting is shown in "PRODUCT SPECIFICATIONS" on page 3 of this manual.

IN-LINE FUEL FILTER (See Fig. 19)

The fuel filter should be replaced once each season. If fuel filter becomes clogged, obstructing fuel flow to carburetor, replacement is required.

- With engine cool, remove filter and plug fuel line sections.
- Place new fuel filter in position in fuel line with arrow pointing towards carburetor.
- Be sure there are no fuel line leaks and clamps are properly positioned.
- Immediately wipe up any spilled gasoline.

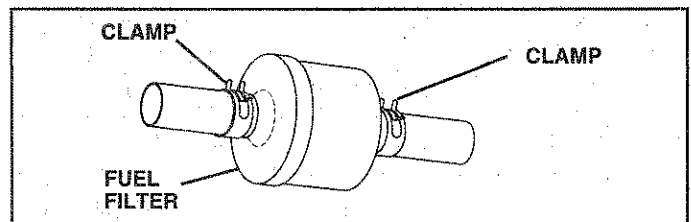

FIG. 19

CLEANING

- Clean engine, battery, seat, finish, etc. of all foreign matter.
- Keep finished surfaces and wheels free of all gasoline, oil, etc.
- Protect painted surfaces with automotive type wax.

We do not recommend using a garden hose to clean your tractor unless the electrical system, muffler, air filter and carburetor are covered to keep water out. Water in engine can result in a shortened engine life.

SERVICE AND ADJUSTMENTS

CAUTION: BEFORE PERFORMING ANY SERVICE OR ADJUSTMENTS:



- Depress clutch/brake pedal fully and set parking brake.
- Place motion control lever in neutral (N) position.
- Place attachment clutch in "DISENGAGED" position.
- Turn ignition key "OFF" and remove key.
- Make sure the blades and all moving parts have completely stopped.
- Disconnect spark plug wire from spark plug and place wire where it cannot come in contact with plug.

TO REMOVE MOWER (See Fig. 20)

- Place attachment clutch in "DISENGAGED" position.
- Turn height adjustment knob to lowest setting.
- Lower mower to its lowest position.
- Remove retainer spring holding anti-swaybar to chassis bracket and disengage anti-swaybar from bracket.
- Remove retainer springs from suspension arms at deck and disengage arms from deck.
- Raise attachment lift to its highest position.
- Remove two retainer springs from each front link and remove links.

- Slide mower forward and remove belt from electric clutch pulley.
- Slide mower out from under right side of tractor.

IMPORTANT: IF AN ATTACHMENT OTHER THAN THE MOWER DECK IS TO BE MOUNTED ON THE TRACTOR, REMOVE THE FRONT LINKS.

TO INSTALL MOWER

Follow procedure described in "INSTALL MOWER AND DRIVE BELT" in the Assembly section of this manual.

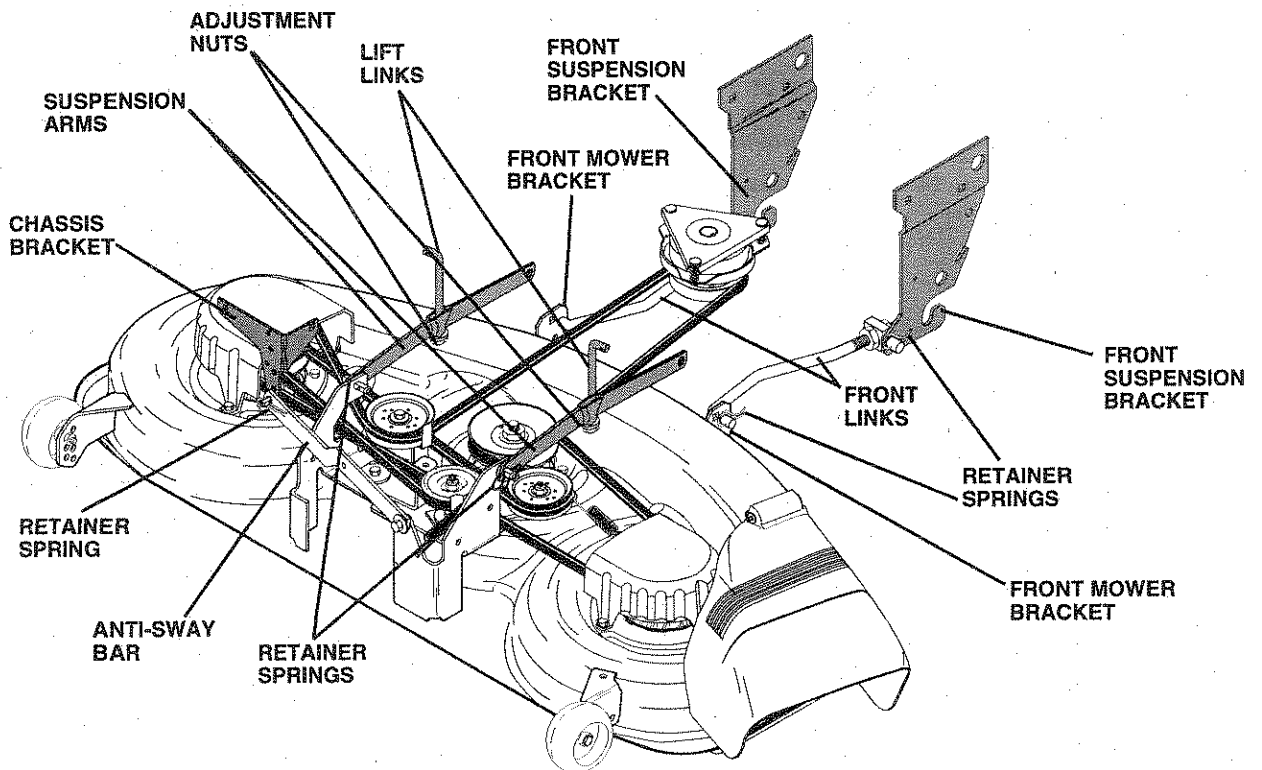

FIG. 20

SERVICE AND ADJUSTMENTS

TO LEVEL MOWER HOUSING

Adjust the mower while tractor is parked on level ground or driveway. Make sure tires are properly inflated (See "PRODUCT SPECIFICATIONS" on page 3 of this manual). If tires are over or underinflated, you will not properly adjust your mower.

SIDE-TO-SIDE ADJUSTMENT (See Figs. 21 and 22)

- Raise mower to its highest position.
- At the midpoint of both sides of mower, measure height from bottom edge of mower to ground. Distance "A" on both sides of mower should be the same or within 1/4" of each other.
- If adjustment is necessary, make adjustment on one side of mower only.
- To raise one side of mower, tighten lift link adjustment nut on that side.
- To lower one side of mower, loosen lift link adjustment nut on that side.

NOTE: Each full turn of adjustment nut will change mower height about 1/8".

- Recheck measurements after adjusting.

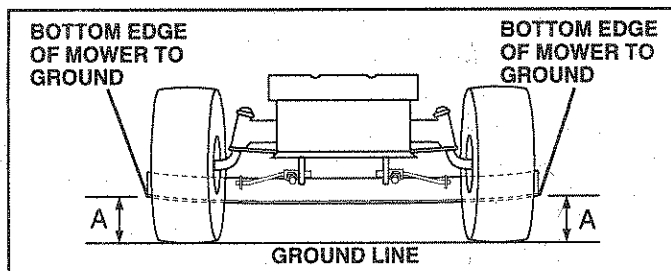

FIG. 21

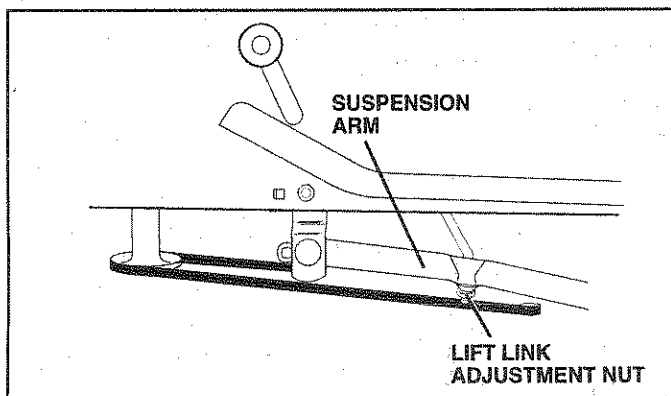

FIG. 22

FRONT-TO-BACK ADJUSTMENT (See Figs. 23 and 24)

IMPORTANT: DECK MUST BE LEVEL SIDE-TO-SIDE. IF THE FOLLOWING FRONT-TO-BACK ADJUSTMENT IS NECESSARY, BE SURE TO ADJUST BOTH FRONT LINKS EQUALLY SO MOWER WILL STAY LEVEL SIDE-TO-SIDE.

To obtain the best cutting results, the mower housing should be adjusted so that the front is approximately 1/4" to 3/4" lower than the rear when the mower is in its highest position.

Check adjustment on right side of tractor. Measure distance "D" directly in front and behind the mandrel at bottom edge of mower housing as shown.

- Before making any necessary adjustments, check that both front links are equal in length. Both links should be approximately 10-3/8".
- If links are not equal in length, adjust one link to same length as other link.
- To lower front of mower loosen nut "E" on both front links an equal number of turns.
- When distance "D" is 1/4" to 3/4" lower at front than rear, tighten nuts "F" against trunnion on both front links.
- To raise front of mower, loosen nut "F" from trunnion on both front links. Tighten nut "E" on both front links an equal number of turns.
- When distance "D" is 1/4" to 3/4" lower at front than rear, tighten nut "F" against trunnion on both front links.
- Recheck side-to-side adjustment.

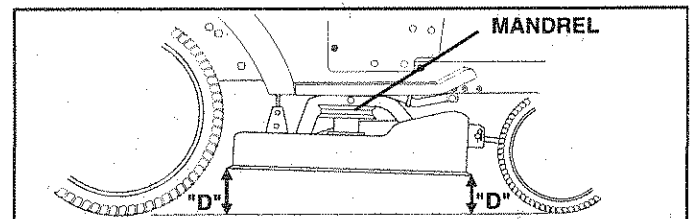

FIG. 23

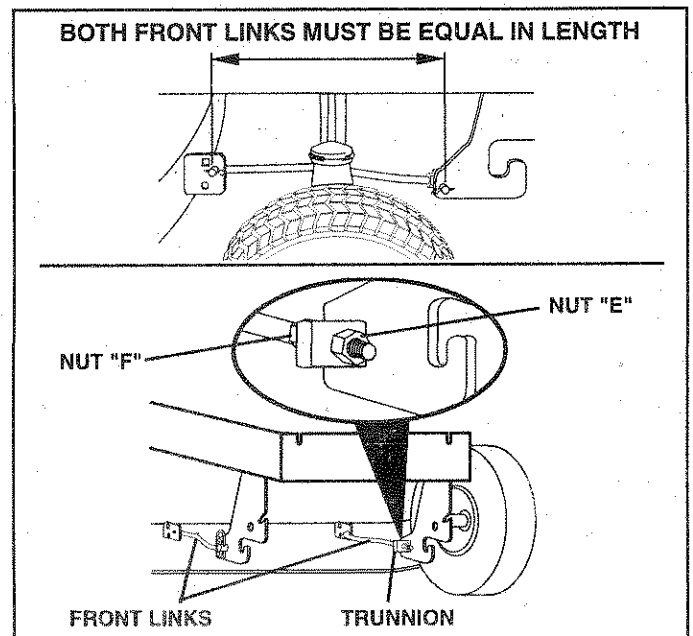

FIG. 24

SERVICE AND ADJUSTMENTS

TO REPLACE MOWER DRIVE BELT

MOWER DRIVE BELT REMOVAL (See Fig. 25) -

- Park tractor on a level surface. Engage parking brake.
- Remove four screws from L.H. mandrel cover and remove cover.
- Roll belt over the top of L.H. mandrel pulley.
- Remove belt from electric clutch pulley.
- Remove belt from idler pulleys.
- Remove any dirt or grass clippings which may have accumulated around mandrels and entire upper deck surface.
- Check primary idler arm and two idlers to see that they rotate freely.
- Be sure spring is securely hooked to primary idler arm and bolt in mower housing.

MOWER DRIVE BELT INSTALLATION (See Fig. 25) -

- Install belt in both idlers. Make sure belt is in both belt keepers at the idlers as shown.
- Install new belt onto electric clutch pulley.
- Roll belt into upper groove of L.H. mandrel pulley.
- Carefully check belt routing making sure belt is in the grooves correctly and inside belt keepers.
- Reassemble L.H. mandrel cover.

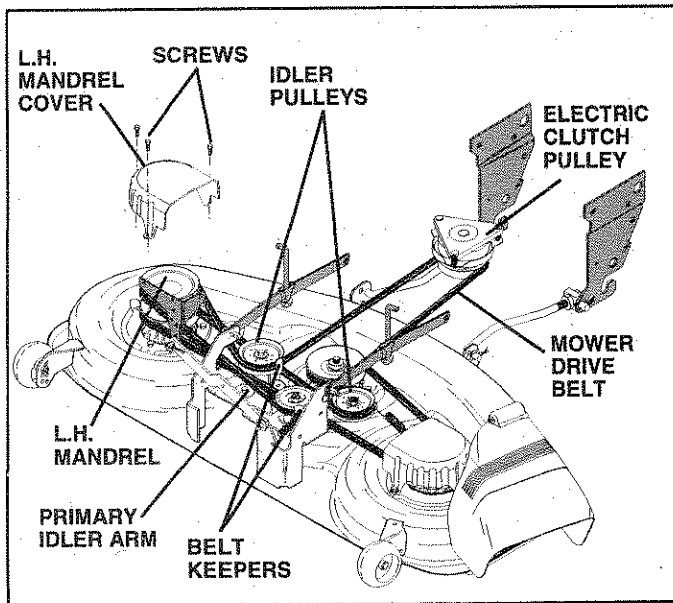

FIG. 25

TO REPLACE MOWER BLADE DRIVE BELT (See Fig. 26)

Park the tractor on level surface. Engage parking brake.

- Remove mower drive belt (See "TO REPLACE MOWER DRIVE BELT" in this section of this manual).
- Remove mower (See "TO REMOVE MOWER" in this section of this manual).
- Remove four screws from R.H. mandrel cover and remove cover. Unhook spring from bolt on mower housing.
- Carefully roll belt off R.H. mandrel pulley.
- Remove belt from center mandrel pulley, idler pulley, and L.H. mandrel pulley.
- Remove any dirt or grass which may have accumulated around mandrels and entire upper deck surface.
- Check secondary idler arm and idler to see that they rotate freely.
- Be sure spring is hooked in secondary idler arm and sway-bar bracket.
- Install new belt in lower groove of L.H. mandrel pulley, idler pulley, and center mandrel pulley as shown.
- Roll belt over R.H. mandrel pulley. Make sure belt is in all grooves properly.
- Reconnect spring to bolt in mower housing and reinstall R.H. mandrel cover.
- Reinstall mower to tractor (See "INSTALL MOWER AND DRIVE BELT" in the Assembly section of this manual).
- Reassemble mower drive belt (See "TO REPLACE MOWER DRIVE BELT" in this section of this manual).

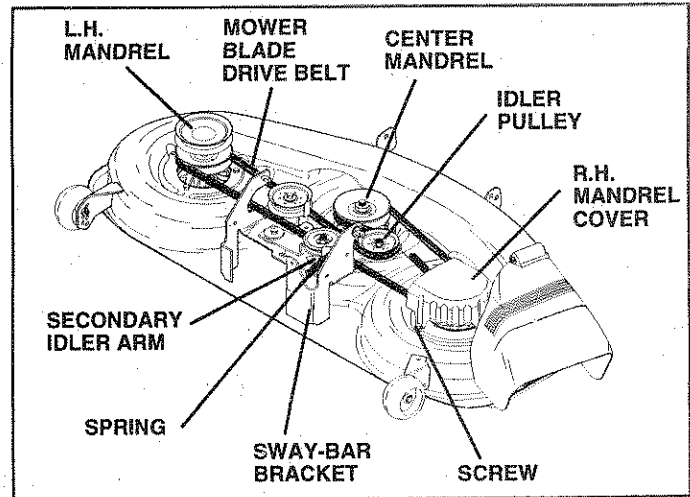

FIG. 26

SERVICE AND ADJUSTMENTS

TO ADJUST ATTACHMENT CLUTCH (See Fig. 27)

The electric clutch should provide years of service. The clutch has a built-in brake that stops the pulley within 5 seconds. Eventually, the internal brake will wear which may cause the mower blades to not engage, or, to not stop as required. Adjustments should be made by your nearest authorized service center/department.

- Make sure attachment clutch and ignition switches are in "OFF" position.
- Adjust the three nylon locknuts until space between clutch plate and rotor measures .012" at all three slot locations cut in the side of brake plate.

NOTE: After installing a new electric clutch, run tractor at full throttle and engage and disengage electric clutch 10 cycles to wear in clutch plate.

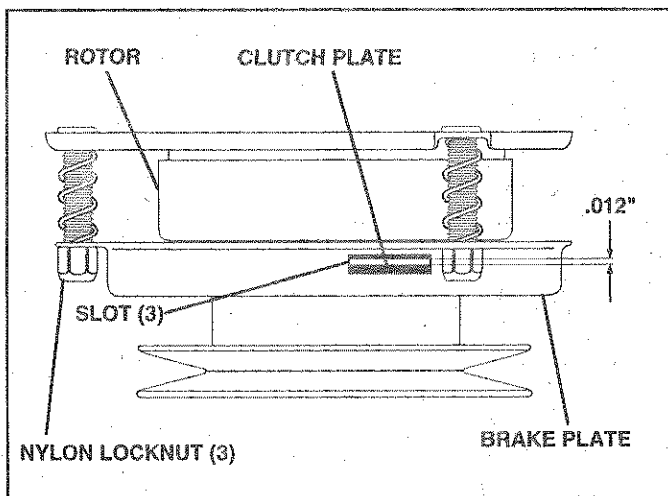

FIG. 27

TO ADJUST BRAKE (See Fig. 28)

Your tractor is equipped with an adjustable brake system which is mounted on the right side of the transaxle.

If tractor requires more than six (6) feet stopping distance at high speed in highest gear, then brake must be adjusted.

- Depress clutch/brake pedal and engage parking brake.
- Measure distance between brake operating arm and nut "A" on brake rod.
- If distance is other than 1-3/4", loosen jam nut and turn nut "A" until distance becomes 1-3/4". Retighten jam nut against nut "A".
- Road test tractor for proper stopping distance as stated above. Readjust if necessary. If stopping distance is still greater than six (6) feet in highest gear, further maintenance is necessary. Contact your nearest authorized service center.

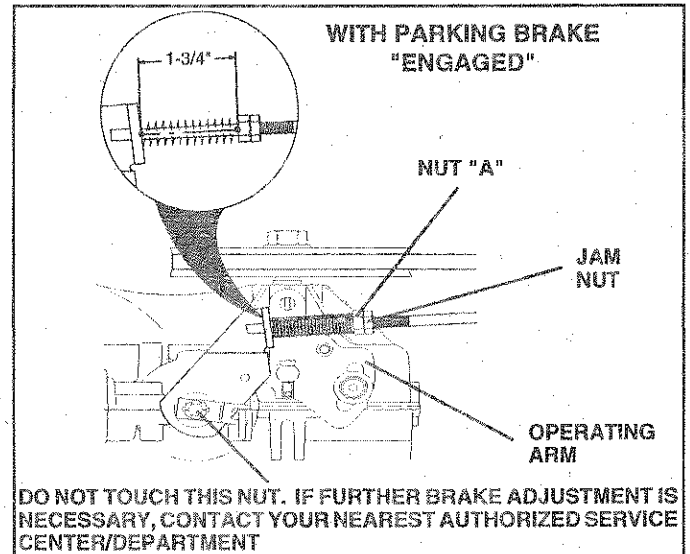

FIG. 28

TO REPLACE MOTION DRIVE BELT (See Fig. 29)

(See Fig. 29)

Park the tractor on level surface. Engage parking brake. For assistance, there is a belt installation guide decal on bottom side of left footrest.

- Remove mower (See "TO REMOVE MOWER" in this section of this manual.)
- Disconnect clutch wire harness.
- Remove clutch locator.
- Remove upper belt keeper.
- Remove belt from stationary idler and clutching idler.
- Pull belt slack toward rear of tractor. Carefully remove belt upwards from transmission input pulley and over cooling fan blades.
- Pull belt toward front of tractor and remove downwards from around electric clutch.
- Install new belt by reversing above procedure.

IMPORTANT: MAKE SURE UPPER BELT KEEPER IS POSITIONED PROPERLY BETWEEN LOCATOR TABS AND ELECTRIC CLUTCH WIRE CONNECTION IS SECURE.

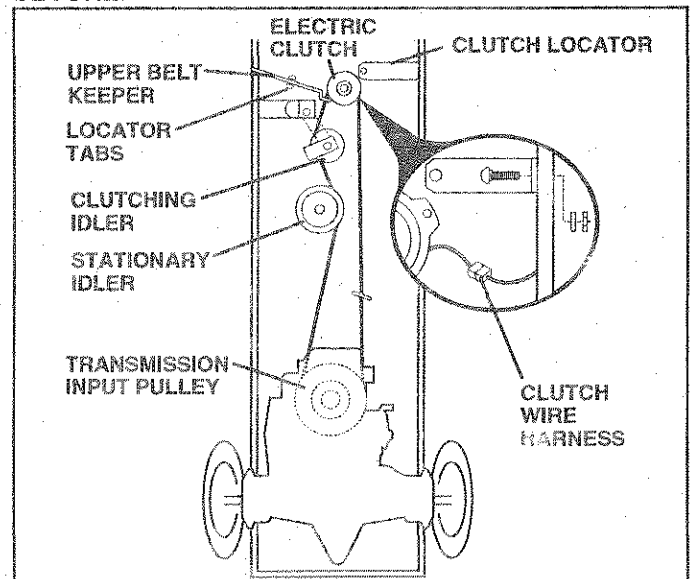

FIG. 29

SERVICE AND ADJUSTMENTS

TO ADJUST MOTION CONTROL LEVER (See Fig. 30)

The motion control lever has been preset at the factory and adjustment should not be necessary.

If for any reason the motion control lever will not hold its position while at a selected speed, it may be adjusted at the friction pack located on the right side of transmission.

- Park tractor on level surface. Stop tractor by turning ignition key to "OFF" position, and engage parking brake.
- Adjust motion control lever by tightening adjustment locknut one half (1/2) turn.

NOTE: If for any reason the effort to move the motion control lever becomes too excessive, reverse the above adjustment procedure by loosening locknut 1/4 to 1/2 turn.

Road test tractor after adjustment and repeat procedure if necessary.

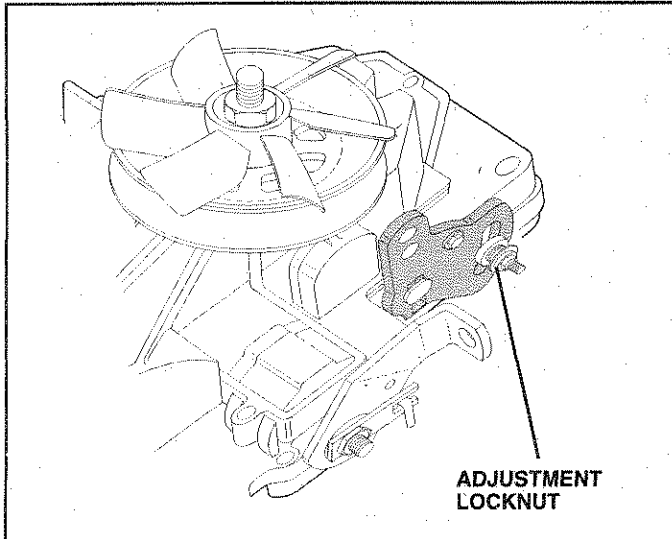

FIG. 30

TRANSMISSION REMOVAL/REPLACEMENT

Should your transmission require removal for service or replacement, it should be purged after reinstallation and before operating the tractor. See "PURGE TRANSMISSION" in Operation section of this manual.

TO ADJUST STEERING WHEEL ALIGNMENT

If steering wheel crossbars are not horizontal (left to right) when wheels are positioned straight forward, remove steering wheel and reassemble per instructions in the Assembly section of this manual.

FRONT WHEEL TOE-IN/CAMBER

The front wheel toe-in and camber are not adjustable on your tractor. If damage has occurred to affect the front wheel toe-in or camber, contact your nearest authorized service center/department.

TO REMOVE WHEEL FOR REPAIRS (See Fig. 31)

- Block up axle securely.
- Remove axle cover, retaining ring and washers to allow wheel removal (rear wheel contains a square key - Do not lose).
- Repair tire and reassemble.
- On rear wheels only: align grooves in rear wheel hub and axle. Insert square key.
- Replace washers and snap retaining ring securely in axle groove.
- Replace axle cover.

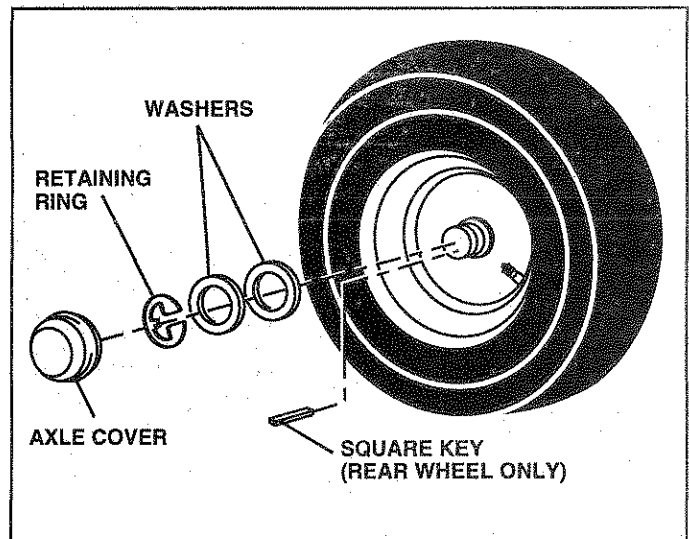

FIG. 31

SERVICE AND ADJUSTMENTS

TO START ENGINE WITH A WEAK BATTERY (See Fig. 32)



CAUTION: Lead-acid batteries generate explosive gases. Keep sparks, flame and smoking materials away from batteries. Always wear eye protection when around batteries.

If your battery is too weak to start the engine, it should be recharged. If "jumper cables" are used for emergency starting, follow this procedure:

IMPORTANT: YOUR TRACTOR IS EQUIPPED WITH A 12 VOLT NEGATIVE GROUND SYSTEM. THE OTHER VEHICLE MUST ALSO BE A 12 VOLT NEGATIVE GROUND SYSTEM. DO NOT USE YOUR TRACTOR BATTERY TO START OTHER VEHICLES.

TO ATTACH JUMPER CABLES -

- Connect each end of the RED cable to the POSITIVE (+) terminal of each battery, taking care not to short against chassis.
- Connect one end of the BLACK cable to the NEGATIVE (-) terminal of fully charged battery.
- Connect the other end of the BLACK cable to good CHASSIS GROUND, away from fuel tank and battery.

TO REMOVE CABLES, REVERSE ORDER -

- BLACK cable first from chassis and then from the fully charged battery.
- RED cable last from both batteries.

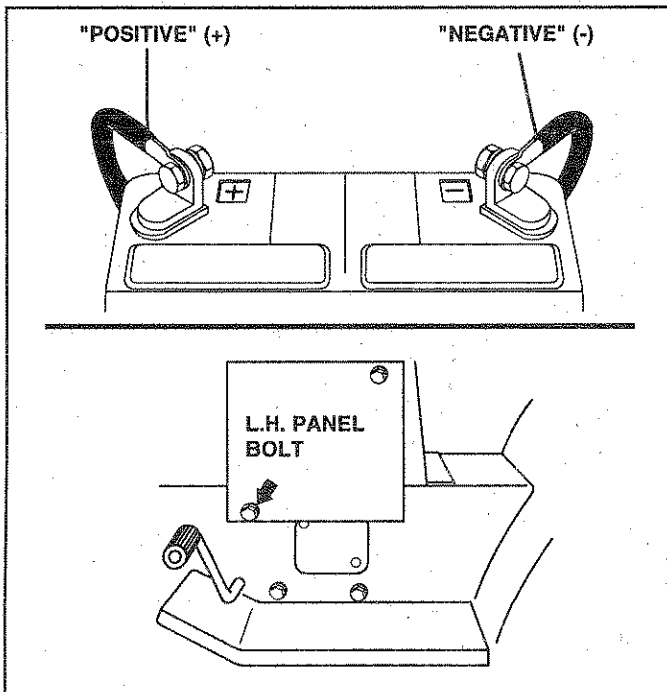

FIG. 32

TO REPLACE HEADLIGHT BULB

- Raise hood.
- Pull bulb holder out of the hole in the backside of the grill.
- Replace bulb in holder and push bulb holder securely back into the hole in the backside of the grill.
- Close hood.

INTERLOCKS AND RELAYS

Loose or damaged wiring may cause your tractor to run poorly, stop running, or prevent it from starting.

- Check wiring. See electrical wiring diagram in the Repair Parts section of this manual.

TO REPLACE FUSE

Replace with 30 amp automotive-type plug-in fuse. The fuse holder is located behind the dash.

TO REMOVE HOOD AND GRILL ASSEMBLY (See Fig. 33)

- Raise hood.
- Unsnap headlight wire connector.
- Stand in front of tractor. Grasp hood at sides, tilt toward engine and lift off of tractor.
- To replace, reverse above procedures.

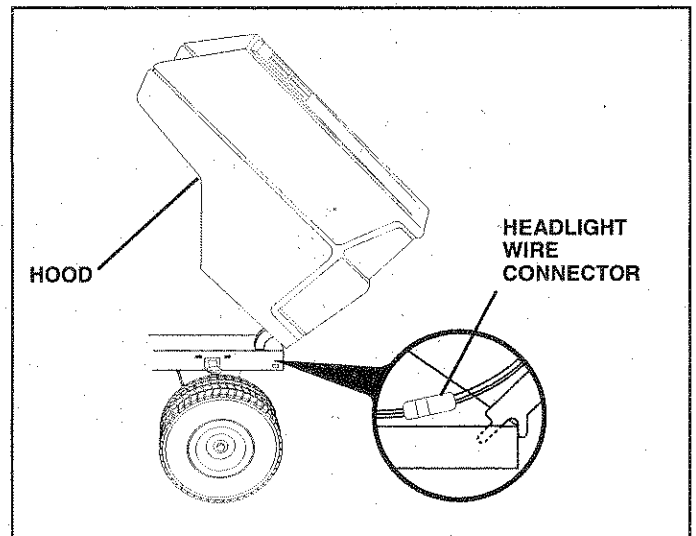

FIG. 33

SERVICE AND ADJUSTMENTS

ENGINE

TO ADJUST THROTTLE CONTROL CABLE (See Fig. 34)

The throttle control has been preset at the factory and adjustment should not be necessary. Check adjustment as described below before loosening cable. If adjustment is necessary, proceed as follows:

- With engine not running, move throttle control lever from slow (☞) to choke (N) position. Slowly move lever from choke (N) to fast (☛) position.
- Check to see if hole in throttle lever and hole in speed control bracket are aligned.
- If holes are not aligned, loosen cable clamp screw and align the holes by inserting a pencil or a 1/4" drill bit through both holes.
- Pull throttle cable up to remove slack and tighten cable clamp screw. Remove alignment pencil or drill bit.

TO ADJUST CARBURETOR (See Fig. 35)

The carburetor has been preset at the factory and adjustment should not be necessary. However, minor adjustment may be required to compensate for differences in fuel, temperature, altitude or load. If the carburetor does need adjustment, proceed as follows:

In general, turning the adjusting needles **in** (clockwise) decreases the supply of fuel to the engine giving a leaner fuel/air mixture. Turning the adjusting needles **out** (counterclockwise) increases the supply of fuel to the engine giving a richer fuel/air mixture.

IMPORTANT: DAMAGE TO THE NEEDLES AND THE SEATS IN CARBURETOR MAY RESULT IF NEEDLE IS TURNED IN TOO TIGHT.

NOTE: The carburetor on this engine is low emission. It is equipped with an idle fuel adjusting needle with a limiter cap, which allows some adjustment within the limits allowed by the cap. Do not attempt to remove the limiter cap. The limiter cap cannot be removed without breaking the adjusting needle.

- Be sure you have a clean air filter and the throttle control cable is adjusted properly (see above).
- Start engine and allow to warm for five minutes. Make adjustments with engine running and shift/motion control lever in neutral (N) position.
- **Idle speed setting** - With throttle control lever in slow (☞) position, engine should idle at 1750 RPM. If engine idles too slow or fast, turn idle speed adjusting screw in or out until correct idle is attained.
- **Idle fuel needle setting** - With throttle control lever in slow (☞) position, turn idle fuel adjustment needle **in** (clockwise) until engine begins to die and then turn **out** (counterclockwise) until engine runs rough. Turn needle to a point midway between those two positions.
- Recheck idle speed. Readjust if necessary.

ACCELERATION TEST -

- Move throttle control lever from slow (☞) to fast (☛) position. If engine hesitates or dies, turn idle fuel adjusting needle **out** (counterclockwise) 1/8 turn. Repeat test and continue to adjust, if necessary, until engine accelerates smoothly.

High speed stop is factory adjusted. Do not adjust - damage may result.

IMPORTANT: NEVER TAMPER WITH THE ENGINE GOVERNOR, WHICH IS FACTORY SET FOR PROPER ENGINE SPEED. OVERSPEEDING THE ENGINE ABOVE THE FACTORY HIGH SPEED SETTING CAN BE DANGEROUS. IF YOU THINK THE ENGINE-GOVERNED HIGH SPEED NEEDS ADJUSTING, CONTACT YOUR NEAREST AUTHORIZED SERVICE CENTER/DEPARTMENT, WHICH HAS PROPER EQUIPMENT AND EXPERIENCE TO MAKE ANY NECESSARY ADJUSTMENTS.

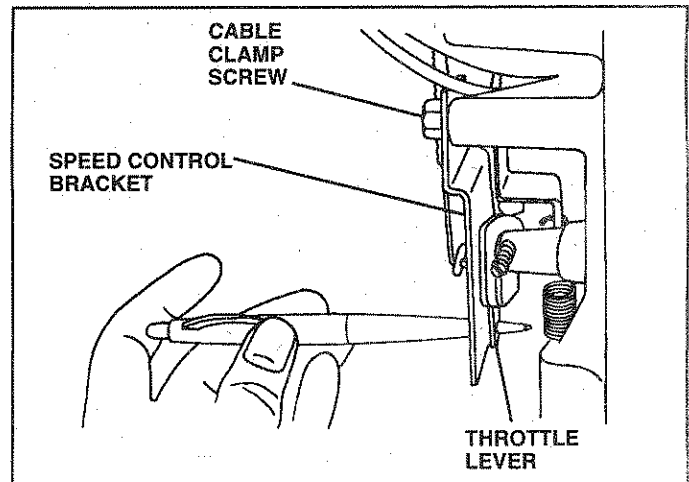

FIG. 34

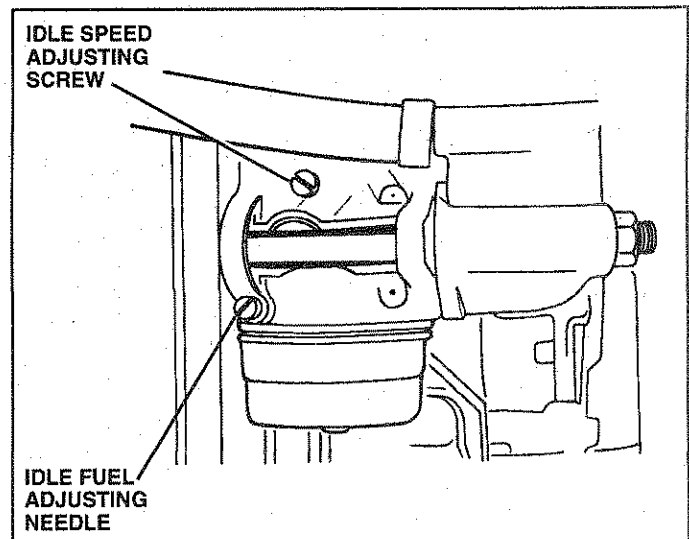

FIG. 35

STORAGE

Immediately prepare your tractor for storage at the end of the season or if the tractor will not be used for 30 days or more.



CAUTION: Never store the tractor with gasoline in the tank inside a building where fumes may reach an open flame or spark. Allow the engine to cool before storing in any enclosure.

TRACTOR

Remove mower from tractor for winter storage. When mower is to be stored for a period of time, clean it thoroughly, remove all dirt, grease, leaves, etc. Store in a clean, dry area.

- Clean entire tractor (See "CLEANING" in the Customer Responsibilities section of this manual).
- Inspect and replace belts, if necessary (See belt replacement instructions in the Service and Adjustments section of this manual).
- Lubricate as shown in the Customer Responsibilities section of this manual.
- Be sure that all nuts, bolts and screws are securely fastened. Inspect moving parts for damage, breakage and wear. Replace if necessary.
- Touch up all rusted or chipped paint surfaces; sand lightly before painting.

BATTERY

- Fully charge the battery for storage.
- After a period of time in storage, battery may require recharging.
- To help prevent corrosion and power leakage during long periods of storage, battery cables should be disconnected and battery cleaned thoroughly (see "TO CLEAN BATTERY AND TERMINALS" in the Customer Responsibilities section of this manual).
- After cleaning, leave cables disconnected and place cables where they cannot come in contact with battery terminals.
- Be sure battery drain tube is securely attached.
- If battery is removed from tractor for storage, do not store battery directly on concrete or damp surfaces.

ENGINE

FUEL SYSTEM

IMPORTANT: IT IS IMPORTANT TO PREVENT GUM DEPOSITS FROM FORMING IN ESSENTIAL FUEL SYSTEM PARTS SUCH AS CARBURETOR, FUEL FILTER, FUEL HOSE, OR TANK DURING STORAGE. ALSO, EXPERIENCE INDICATES THAT ALCOHOL BLENDED FUELS (CALLED GASOHOL OR USING ETHANOL OR METHANOL) CAN ATTRACT MOISTURE WHICH LEADS TO SEPARATION AND FORMATION OF ACIDS DURING STORAGE. ACIDIC GAS CAN DAMAGE THE FUEL SYSTEM OF AN ENGINE WHILE IN STORAGE.

- Drain the fuel tank.
- Start the engine and let it run until the fuel lines and carburetor are empty.
- Never use engine or carburetor cleaner products in the fuel tank or permanent damage may occur.
- Use fresh fuel next season.

NOTE: Fuel stabilizer is an acceptable alternative in minimizing the formation of fuel gum deposits during storage. Add stabilizer to gasoline in fuel tank or storage container. Always follow the mix ratio found on stabilizer container. Run engine at least 10 minutes after adding stabilizer to allow the stabilizer to reach the carburetor. Do not drain the gas tank and carburetor if using fuel stabilizer.

ENGINE OIL

Drain oil (with engine warm) and replace with clean engine oil. (See "ENGINE" in the Customer Responsibilities section of this manual).

CYLINDERS

- Remove spark plug(s).
- Pour one ounce of oil through spark plug hole(s) into cylinder(s).
- Turn ignition key to "START" position for a few seconds to distribute oil.
- Replace with new spark plug(s).

OTHER

- Do not store gasoline from one season to another.
- Replace your gasoline can if your can starts to rust. Rust and/or dirt in your gasoline will cause problems.
- If possible, store your tractor indoors and cover it to give protection from dust and dirt.
- Cover your tractor with a suitable protective cover that does not retain moisture. Do not use plastic. Plastic cannot breathe which allows condensation to form and will cause your tractor to rust.

IMPORTANT: NEVER COVER TRACTOR WHILE ENGINE AND EXHAUST AREAS ARE STILL WARM.

TROUBLESHOOTING POINTS

PROBLEM	CAUSE	CORRECTION
Will not start	<ol style="list-style-type: none"> 1. Out of fuel. 2. Engine not "CHOKED" properly. 3. Engine flooded. 4. Bad spark plug. 5. Dirty air filter. 6. Dirty fuel filter. 7. Water in fuel. 8. Loose or damaged wiring. 9. Carburetor out of adjustment. 10. Engine valves out of adjustment. 	<ol style="list-style-type: none"> 1. Fill fuel tank. 2. See "TO START ENGINE" in Operation section. 3. Wait several minutes before attempting to start. 4. Replace spark plug. 5. Clean/replace air filter. 6. Replace fuel filter. 7. Drain fuel tank and carburetor, refill tank with fresh gasoline and replace fuel filter. 8. Check all wiring. 9. Contact an authorized service center/department. 10. Contact an authorized service center/department.
Hard to start	<ol style="list-style-type: none"> 1. Dirty air filter. 2. Bad spark plug. 3. Weak or dead battery. 4. Dirty fuel filter. 5. Stale or dirty fuel. 6. Loose or damaged wiring. 7. Carburetor out of adjustment. 8. Engine valves out of adjustment. 	<ol style="list-style-type: none"> 1. Clean/replace air filter. 2. Replace spark plug. 3. Recharge or replace battery. 4. Replace fuel filter. 5. Drain fuel tank and refill with fresh gasoline. 6. Check all wiring. 7. Contact an authorized service center/department. 8. Contact an authorized service center/department.
Engine will not turn over	<ol style="list-style-type: none"> 1. Clutch/brake pedal not depressed. 2. Attachment clutch is engaged. 3. Weak or dead battery. 4. Blown fuse. 5. Corroded battery terminals. 6. Loose or damaged wiring. 7. Faulty ignition switch. 8. Faulty solenoid or starter. 9. Faulty operator presence switch(es). 	<ol style="list-style-type: none"> 1. Depress clutch/brake pedal. 2. Disengage attachment clutch. 3. Recharge or replace battery. 4. Replace fuse. 5. Clean battery terminals. 6. Check all wiring. 7. Check/replace ignition switch. 8. Check/replace solenoid or starter. 9. Contact an authorized service center/department.
Engine clicks but will not start	<ol style="list-style-type: none"> 1. Weak or dead battery. 2. Corroded battery terminals. 3. Loose or damaged wiring. 4. Faulty solenoid or starter. 	<ol style="list-style-type: none"> 1. Recharge or replace battery. 2. Clean battery terminals. 3. Check all wiring. 4. Check/replace solenoid or starter.
Loss of power	<ol style="list-style-type: none"> 1. Cutting too much grass/too fast. 2. Throttle in "CHOKE" position. 3. Build-up of grass, leaves and trash under mower. 4. Dirty air filter. 5. Low oil level/dirty oil. 6. Faulty spark plug. 7. Dirty fuel filter. 8. Stale or dirty fuel. 9. Water in fuel. 10. Spark plug wire loose. 11. Dirty engine air screen/fins. 12. Dirty/clogged muffler. 13. Loose or damaged wiring. 14. Carburetor out of adjustment. 15. Engine valves out of adjustment. 	<ol style="list-style-type: none"> 1. Set in "Higher Cut" position/reduce speed. 2. Adjust throttle control. 3. Clean underside of mower housing. 4. Clean/replace air filter. 5. Check oil level/change oil. 6. Clean and regap or change spark plug. 7. Replace fuel filter. 8. Drain fuel tank and refill with fresh gasoline. 9. Drain fuel tank and carburetor, refill tank with fresh gasoline and replace fuel filter. 10. Connect and tighten spark plug wire. 11. Clean engine air screen/fins. 12. Clean/replace muffler. 13. Check all wiring. 14. Contact an authorized service center/department. 15. Contact an authorized service center/department.
Excessive vibration	<ol style="list-style-type: none"> 1. Worn, bent or loose blade. 2. Bent blade mandrel. 3. Loose/damaged part(s). 	<ol style="list-style-type: none"> 1. Replace blade. Tighten blade bolt. 2. Replace blade mandrel. 3. Tighten loose part(s). Replace damaged parts.

TROUBLESHOOTING POINTS

PROBLEM	CAUSE	CORRECTION
Engine continues to run when operator leaves seat with attachment clutch engaged	<ol style="list-style-type: none"> 1. Faulty operator-safety presence control system. 	<ol style="list-style-type: none"> 1. Check wiring, switches and connections. If not corrected, contact an authorized service center/department.
Poor cut - uneven	<ol style="list-style-type: none"> 1. Worn, bent or loose blade. 2. Mower deck not level. 3. Buildup of grass, leaves, and trash under mower. 4. Bent blade mandrel. 5. Clogged mower deck vent holes from buildup of grass, leaves, and trash around mandrels. 	<ol style="list-style-type: none"> 1. Replace blade. Tighten blade bolt. 2. Level mower deck. 3. Clean underside of mower housing. 4. Replace blade mandrel. 5. Clean around mandrels to open vent holes.
Mower blades will not rotate	<ol style="list-style-type: none"> 1. Obstruction in clutch mechanism. 2. Worn/damaged mower drive belt. 3. Frozen idler pulley. 4. Frozen blade mandrel. 	<ol style="list-style-type: none"> 1. Remove obstruction. 2. Replace mower drive belt. 3. Replace idler pulley. 4. Replace blade mandrel.
Poor grass discharge	<ol style="list-style-type: none"> 1. Engine speed too slow. 2. Travel speed too fast. 3. Wet grass. 4. Mower deck not level. 5. Low/uneven tire air pressure. 6. Worn, bent or loose blade. 7. Buildup of grass, leaves and trash under mower. 8. Mower drive belt worn. 9. Blades improperly installed. 10. Improper blades used. 11. Clogged mower deck vent holes from buildup of grass, leaves, and trash around mandrels. 	<ol style="list-style-type: none"> 1. Place throttle control in "FAST" position. 2. Shift to slower speed. 3. Allow grass to dry before mowing. 4. Level mower deck. 5. Check tires for proper air pressure. 6. Replace/sharpen blade. Tighten blade bolt. 7. Clean underside of mower housing. 8. Replace mower drive belt. 9. Reinstall blades sharp edge down. 10. Replace with blades listed in this manual. 11. Clean around mandrels to open vent holes.
Headlight(s) not working (if so equipped)	<ol style="list-style-type: none"> 1. Switch is "OFF". 2. Bulb(s) burned out. 3. Faulty light switch. 4. Loose or damaged wiring. 5. Blown fuse. 	<ol style="list-style-type: none"> 1. Turn switch "ON". 2. Replace bulb(s). 3. Check/replace light switch. 4. Check wiring and connections. 5. Replace fuse.
Battery will not charge	<ol style="list-style-type: none"> 1. Bad battery cell(s). 2. Poor cable connections. 3. Faulty regulator (if so equipped). 4. Faulty alternator. 	<ol style="list-style-type: none"> 1. Replace battery. 2. Check/clean all connections. 3. Replace regulator. 4. Replace alternator.
Tractor "creeps" with motion control lever in "neutral" position (Fender shift models only)	<ol style="list-style-type: none"> 1. Motion control lever is out of adjustment. 	<ol style="list-style-type: none"> 1. Adjust motion control lever.
Loss of drive	<ol style="list-style-type: none"> 1. Freewheel control in "disengaged" position. 2. Motion drive belt worn, damaged, or broken. 3. Air trapped in transmission during shipment or servicing. 	<ol style="list-style-type: none"> 1. Place freewheel control in "engaged" position. 2. Replace motion drive belt. 3. Purge transmission.
Engine "backfires" when turning engine "OFF"	<ol style="list-style-type: none"> 1. Engine throttle control not set at "SLOW" position for 30 seconds before stopping engine. 	<ol style="list-style-type: none"> 1. Move throttle control to "SLOW" position and allow to idle for 30 seconds before stopping engine.

TRACTOR - - MODEL NUMBER 917.256611

SCHEMATIC

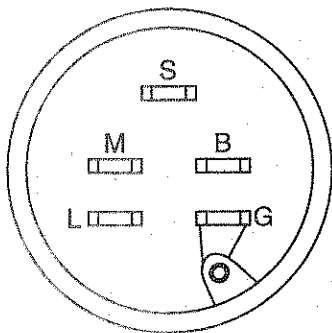
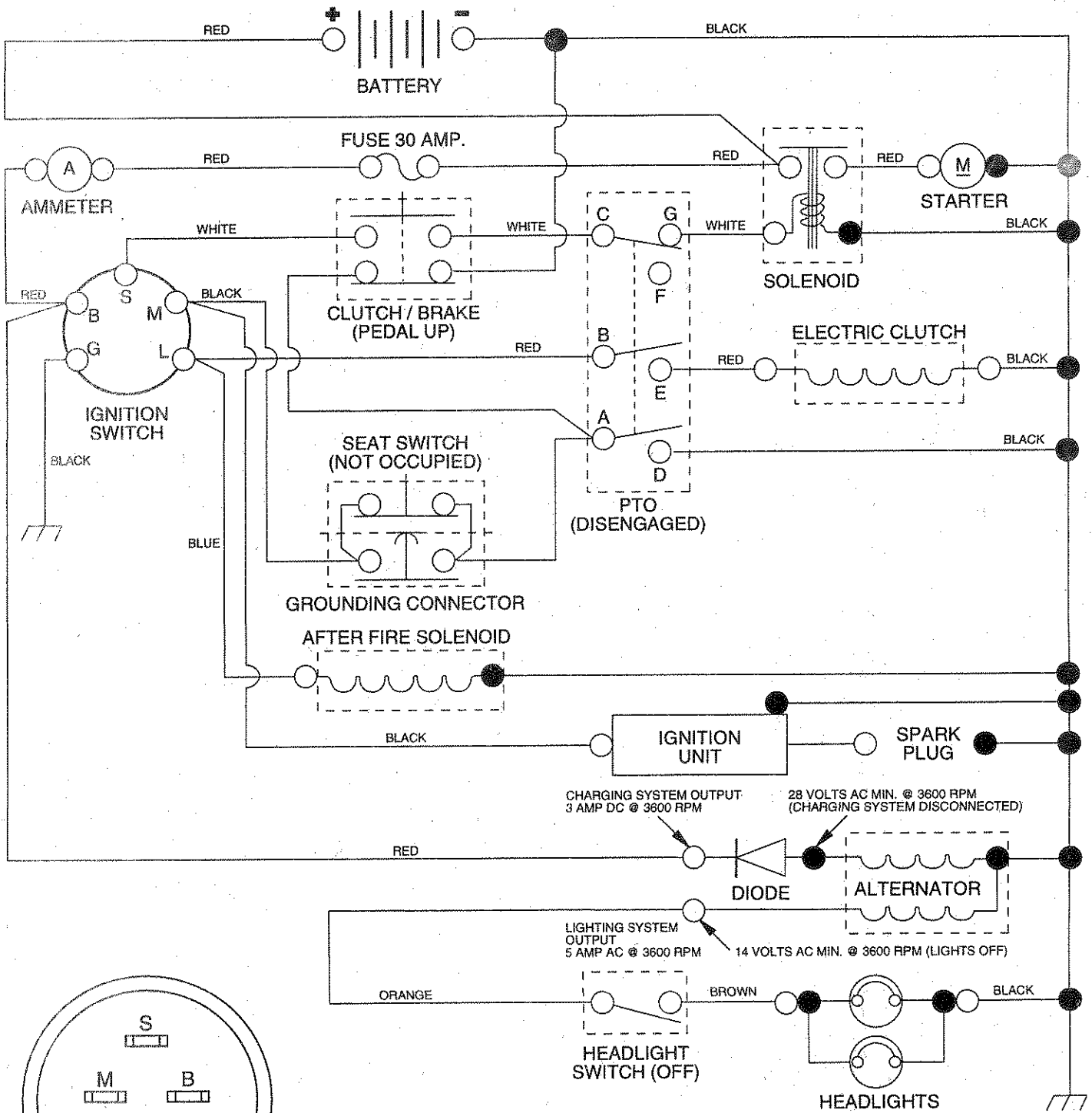

IGNITION SWITCH

POSITION	CIRCUIT
OFF	M + G
ON	B + L
START	B + S + L

● NON-REMOVABLE CONNECTIONS

○ REMOVABLE CONNECTIONS

WIRING INSULATED CLIPS

NOTE: IF WIRING INSULATED CLIPS WERE REMOVED FOR SERVICING OF UNIT, THEY SHOULD BE REPLACED TO PROPERLY SECURE YOUR WIRING

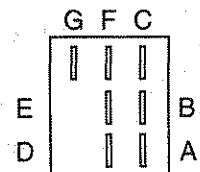

PTO SWITCH

POSITION	CIRCUIT
OFF	C + G
ON	C + F, B + E, A + D

REPAIR PARTS

TRACTOR - - MODEL NUMBER 917.256611

ELECTRICAL

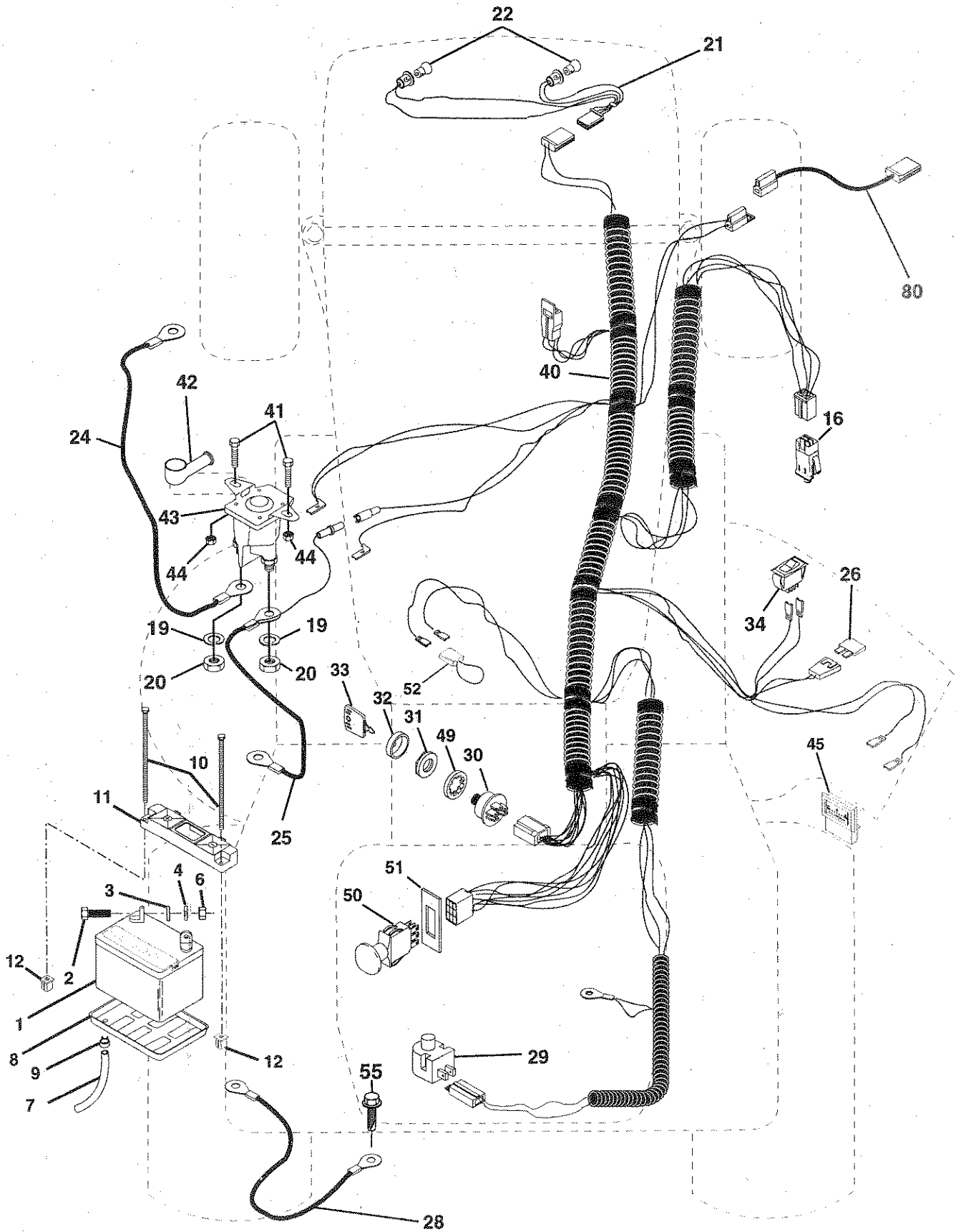

REPAIR PARTS

TRACTOR - - MODEL NUMBER 917.256611

ELECTRICAL

KEY NO.	PART NO.	DESCRIPTION
1	146140	Battery
2	74760412	Bolt, Hex 1/4-20 UNC x 3/4
3	STD551025	Washer
4	STD551125	Washer
6	STD541025	Nut
7	7697J	Tube, Plastic
8	7603J	Tray, Battery
9	109596X	Clamp, Hose
10	145211	Bolt, Btr. Frt 1/4-20 x 7.5
11	145209	Holddown Btr. Dash
12	145769	Nut, Push Nylon 1/4" Battery
16	153664	Switch Intelock Push-In
19	STD551125	Washer, Lock
20	73350400	Nut, Hex, Jam 1/4-20 UNC
21	136850	Harness, Light Socket W/4152J
22	4152J	Bulb, Light
24	146136	Cable Battery
25	146148	Cable, Battery
26	108824X	Fuse
28	145491	Cable, Ground
29	121305X	Switch, Plunger
30	144921	Switch, Ignition
31	140400	Nut, Ignition
32	141226	Cover, Ignition Switch
33	140403	Key, Ignition
34	110712X	Switch, Light
40	149170	Harness, Ignition
41	71110408	Bolt Blk Fin. Hex 1/4-20 x 3/4
42	131563	Cover, Terminal
43	145673	Solenoid
44	73640400	Nut, Lock W/Ins. 1/4-20
45	121433X	Ammeter Rectangular 16 Amp
49	153249	Washer Pinned Delta
50	146283	Switch PTO 3 Pot Red Delta
51	140405	Ring Retainer PTO
52	141940	Wire Loop
55	17490508	Screw Thdrol 5/16-18 x 1/2 TYT
80	146685	Harness Clutch EVX

NOTE: All component dimensions given in U.S. inches
1 inch = 25.4 mm

REPAIR PARTS

TRACTOR - - MODEL NUMBER 917.256611

CHASSIS AND ENCLOSURES

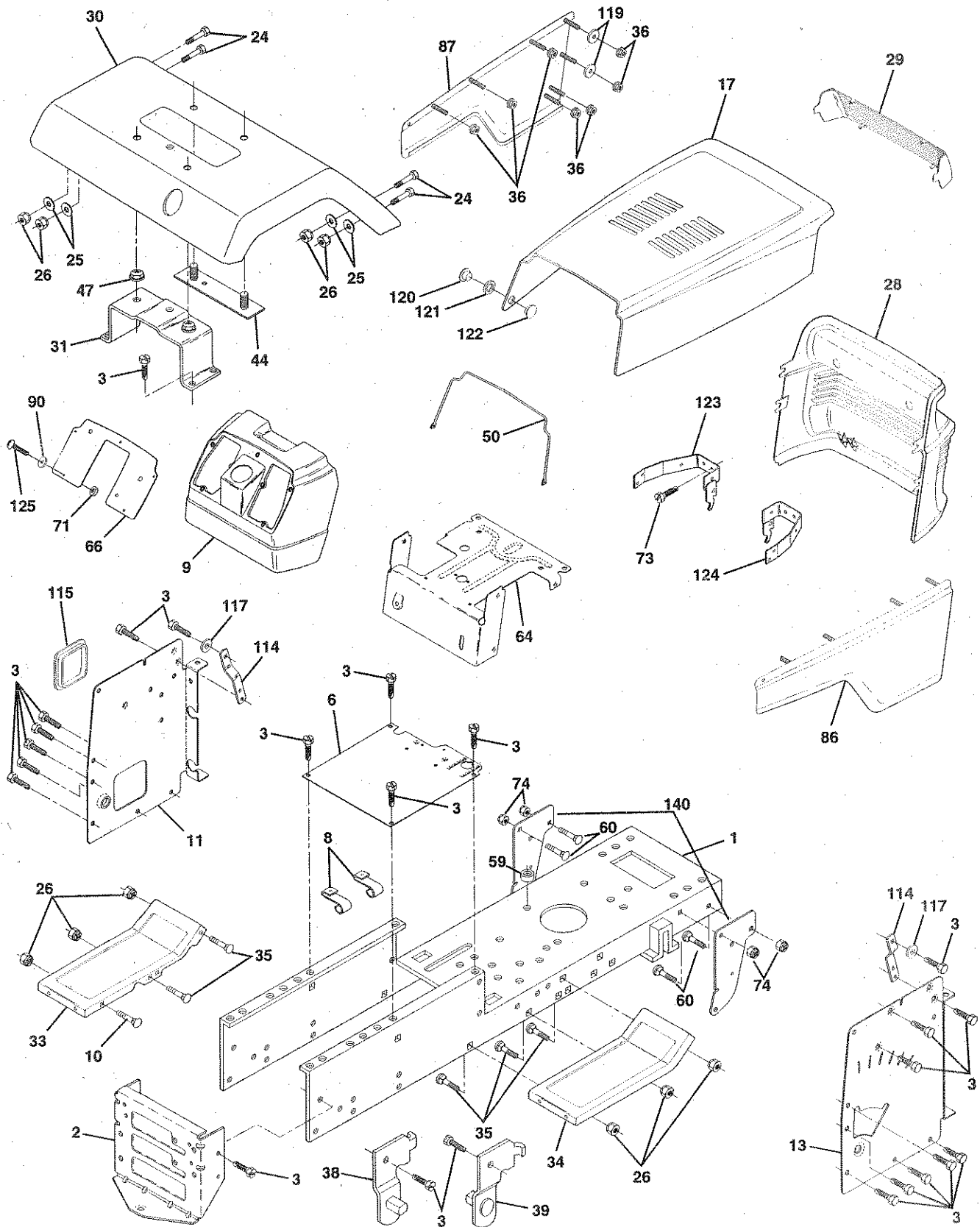

REPAIR PARTS

TRACTOR - - MODEL NUMBER 917.256611

CHASSIS AND ENCLOSURES

KEY NO.	PART NO.	DESCRIPTION
1	151169	Chassis
2	140356	Drawbar
3	17490612	Screw, Thdrol. 3/8-16 x 3/4 Type TT
6	145206	Saddle
8	126471X	Clip, Fuel Line
9	145203	Dash, Plastic
10	72140608	Bolt, Carriage 3/8-16 x 1
11	145218	Panel, Dash, LH
13	145217	Panel, Dash, RH
17	136673X558	Hood Assembly
24	STD523710	Bolt
25	19131312	Washer 13/32 x 13/16 x 12 Gauge
26	STD541437	Nut
28	136373X428	Grill
29	136374	Lens, Bar, Clear
30	140002X558	Fender
31	137113	Bracket Assembly, Fender
33	145244X558	Footrest, LH
34	145243X558	Footrest, RH
35	STD533707	Bolt
36	108067X	Nut, Pal
38	139886	Bracket Assembly, Pivot, LH
39	139887	Bracket Assembly, Pivot, RH
44	140675	Fender Strap
47	105531X	Nut, Push, Nylon
50	137304	Rod, Support Hood
59	110436X	Bushing, Snap, Split
60	72140606	Bolt Rdhd Sqnk 3/8-16unc x 3/4
64	150272	Dash, Lower
66	143485X012	Plate, Dash
71	73640400	Nut
73	17580408	Screw Tap Tite 1/4-20 x 1/2
74	73680600	Nut Crownlock 3/8-16 UNC
86	136670X558	Panel Assembly, RH
87	136671X558	Panel Assembly, LH
90	STD551025	Washer 17/64
114	145349	Bracket, Support, Dash
115	121794X	Cover, Access
117	144283	Washer Serrated Disk 13/32 x 1
119	19092016	Washer 9/32 x 1-1/4 x 16 Ga.
120	137271	Rivet, Ratchet, Female
121	137269	Washer, Nylon
122	137270	Rivet, Ratchet, Male
123	136814	Bracket Assembly, Front Pivot Hinge, LH
124	136813	Bracket Assembly, Front Pivot Hinge, RH
125	74180412	Screw, Machine 1/4-20 x 3/4
140	150556	Bracket Chassis Front 7 Ga.
--	5479J	Plug Button

NOTE: All component dimensions given in U.S. inches
1 inch = 25.4 mm

REPAIR PARTS

TRACTOR -- MODEL NUMBER 917.256611

DRIVE

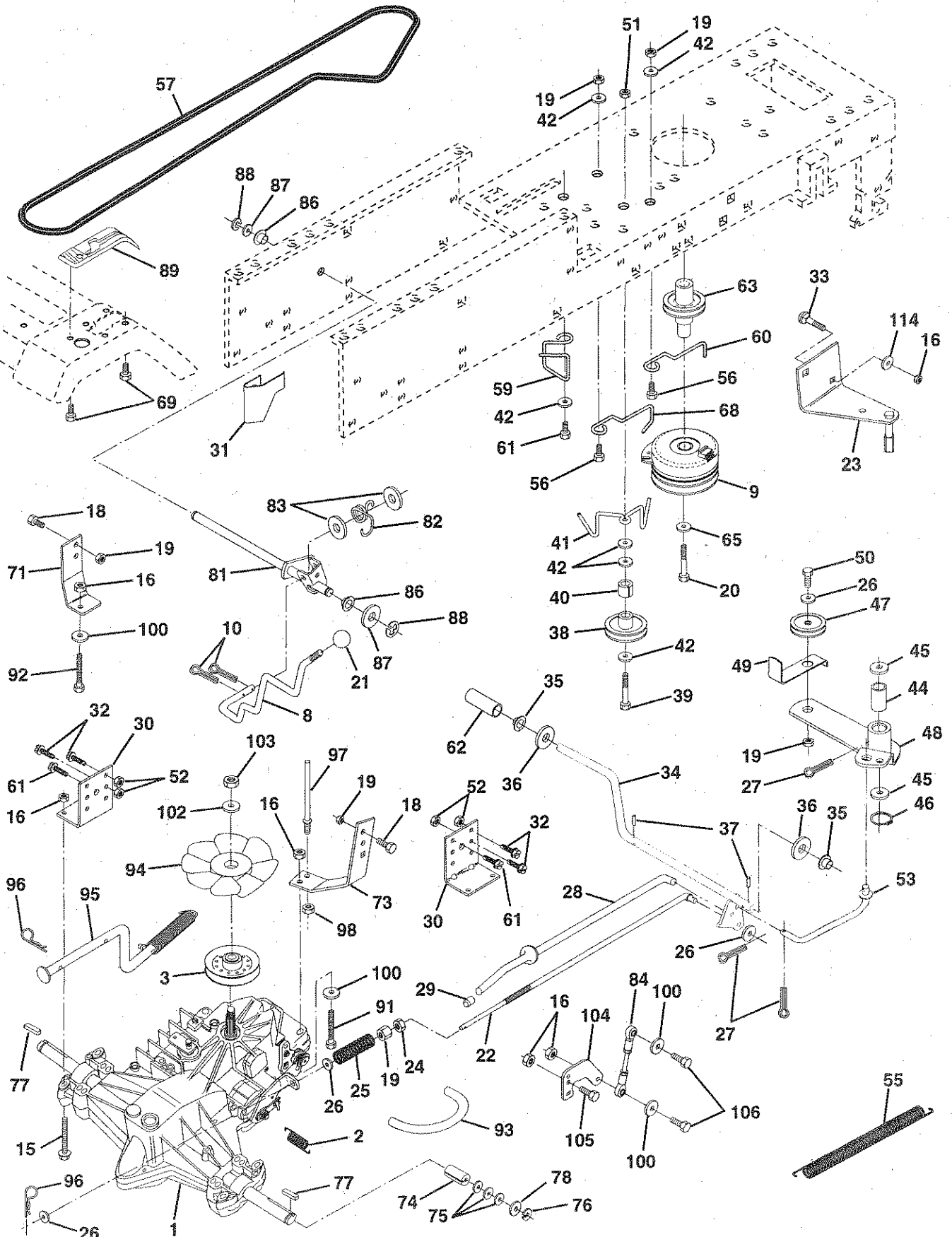

REPAIR PARTS

TRACTOR -- MODEL NUMBER 917.256611

DRIVE

KEY NO.	PART NO.	DESCRIPTION	KEY NO.	PART NO.	DESCRIPTION
1	150071	Transaxle Assembly	55	105709X	Spring, Return, Clutch
2	142431	Spring, Return, Brake	56	STD523712	Bolt Hex 3/8-16 x 1-1/4
3	143995	Pulley, Transaxle	57	140294	V-Belt, Ground Drive
8	141002	Rod Shift Hydro LT	59	140312	Keeper, Center Span
9	145028	Clutch Elect	60	121218X	Keeper Belt Engine
10	STD561210	Pin Cotter 1/8 x 1 CAD	61	17490612	Screw Thdrol. 3/8-16 x 3/4 Ty. TT
15	74490544	Bolt, Hex Flghd 5/16-18 Gr. 5	62	8883R	Cover, Pedal
16	STD541431	Nut Lock Hex W/Ins. 5/16-18 Unc	63	145868	Pulley, Engine
18	STD523710	Bolt Fin Hex 3/8-16 Unc x 1 Gr. 5	65	STD551143	Washer Lock Hvy HLCL Spr. 7/16
19	STD541437	Nut Lock Hex W/Wsh 3/8-16 Unc	68	105730X	Keeper Belt Engine
20	150280	Bolt Hex 7/16-20 x 4-1/4 Ga. 5	69	142432	Screw
21	130564	Knob, Deluxe 1/2-13	71	140158	Strap Torque Lh Hydro 18/20" T
22	145627	Rod, Brake Hydro	73	140157	Strap Torque Rh Hydro 18/20" T
23	152485	Bracket Asm. Mtg CL EVX	74	121199X	Spacer, Split
24	STD541237	Nut, Hex Jam 3/8-16 UNC	75	121749X	Washer 25/32 x 1-1/4 x 16 Gauge
25	106888X	Spring, Brake Rod	76	12000001	E-Ring
26	STD551037	Washer	77	123583X	Key, Square
27	STD561210	Pin Cotter 1/8 x 3/4 CAD.	78	121748X	Washer 25/32 x 1-5/8 x 16 Gauge
28	145204	Rod, Parking Brake	81	140154	Shaft Asm. Cross Hydro 20" Tires
29	124236X	Cap, Parking Brake	82	123782X	Spring Torsion T/A
30	130807	Bracket, Transaxle	83	19171216	Washer 17/32 x 3/4 x 16 Ga.
31	127275X	Keeper Belt Lh	84	140548	Rod, Tie Hydro 20" Tires
32	STD523107	Bolt Hex Hd 5/16-18 Unc x 3/4	86	71208	Bushing Rod Strig. 629/632 ID
33	STD533107	Bolt RDHD SQNK 5/16-18 x 3/4	87	19212016	Washer 21/32 x 1-1/4 x 16 Ga.
34	122409X	Shaft, Foot Pedal	88	12000008	Ring Klip #5304-62
35	120183X	Bearing, Nylon	89	151146	Console, Shift
36	19211616	Washer	91	74780536	Bolt Fin Hex 5/16-18 x 2-1/4
37	1572H	Pin, Roll	92	74780524	Bolt Fin Hex 5/6-18 Unc x 1-1/2
38	123674X	Pulley, Idler, Flat	93	142564	Line Fuel Hydro 4"
39	STD523727	Bolt	94	140462	Fan, Hydro 7"
40	4470J	Spacer, Split	95	144643	Control Bypass Hydro 20" Tires
41	153399	Keeper, Belt Retainer	96	STD624003	Retainer Spring 1" Zinc/Cad
42	19131312	Washer 13/32 x 13/16 x 12 Gauge	97	140469	Keeper Bolt Rh Hydro 0750. 18/20"
44	105706X	Bearing, Nylon	98	73510600	Nut Keps Hex 3/8-16 Unc
45	110812X	Washer, Hardened	100	19111216	Washer 11/32 x 3/4 x 16 Ga.
46	12000039	Ring, Klip	102	141322	Washer Bellville .501D x 1.50D
47	127783	Pulley, Idler, V-Groove	103	STD541350	Nut, Hex Jam Toplock 1/2-20 Unf
48	123789X	Bellcrank Assembly	104	140156	Arm, Control Hydro
49	123205X	Retainer, Belt	105	71070516	Screw Cap Hex 5/16 x 18 x 1
50	STD523715	Bolt	106	74780520	Bolt Fin Hex 5/16-18 Unc x 1-1/4
51	STD 541437	Nut, Crownlock 3/8-16	114	19111214	Washer 11/32 x 3/4 x 14 Ga.
52	STD541431	Nut, Crownlock 5/16-18 Unc			
53	105710X	Link, Clutch			

NOTE: All component dimensions give in U.S. inches.
1 inch = 25.4 mm.

REPAIR PARTS

TRACTOR -- MODEL NUMBER 256611

STEERING ASSEMBLY

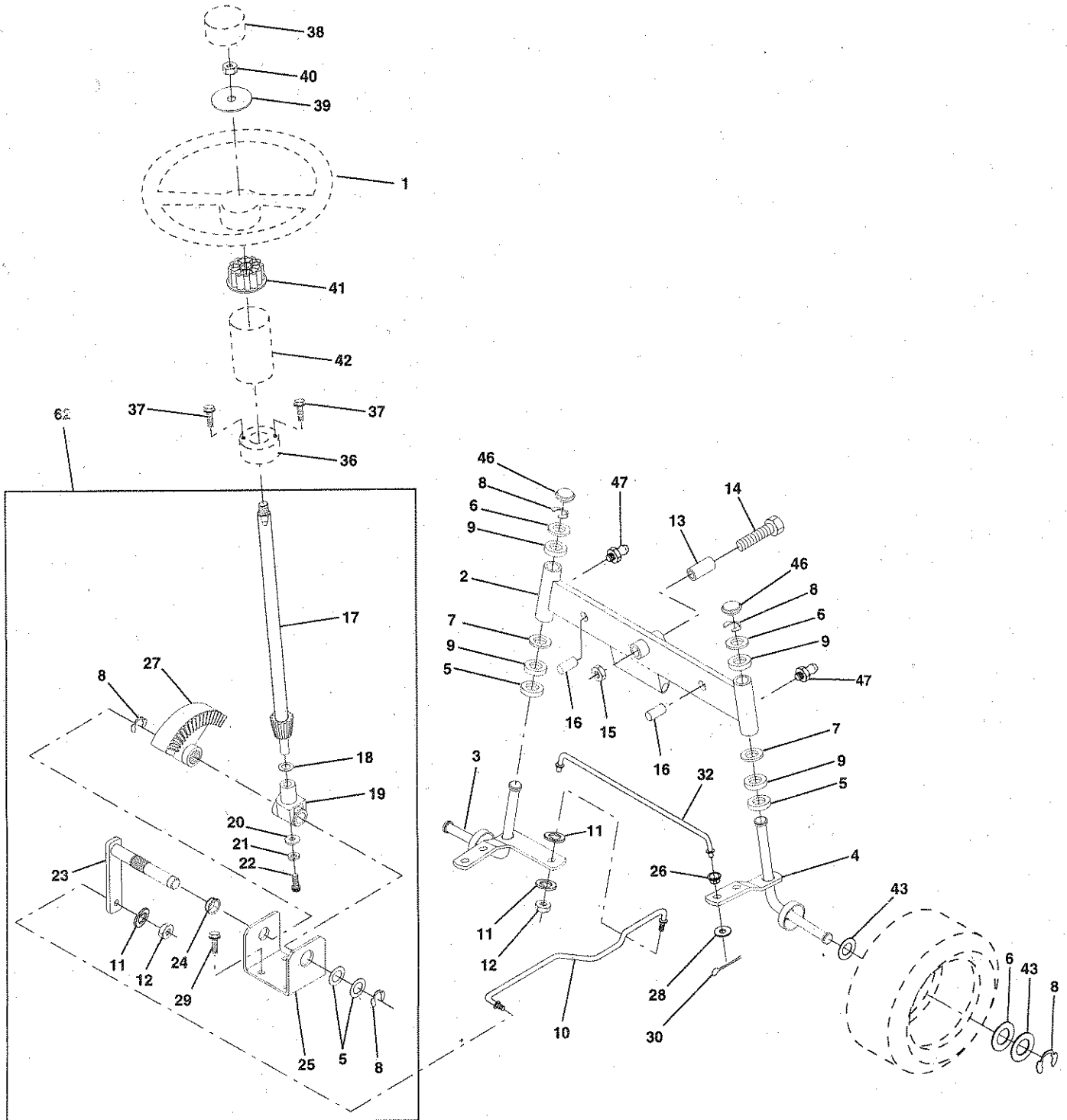

REPAIR PARTS

TRACTOR -- MODEL NUMBER 256611

STEERING ASSEMBLY

KEY NO.	PART NO.	DESCRIPTION
1	121472X	Steering Wheel
2	142033	Axle Assembly, Front
3	135227	Spindle Assembly, LH
4	135228	Spindle Assembly, RH
5	6266H	Bearing, Race, Thrust, Hardened
6	121748X	Washer 25/32 x 1-5/8 x 16 Gauge
7	19272016	Washer 27/32 x 1-1/4 x 16 Gauge
8	12000029	Ring, Klip
9	3366R	Bearing
10	130468	Link, Drag
11	STD551137	Washer, Lock
12	73610600	Nut, Hex, Fin. 3/8-24 UNF
13	110438X	Spacer, Bearing, Front Axle
14	74011056	Bolt, Hex 5/8-11 UNC x 3-1/2
15	73901000	Locknut, Hex, Jam, w/Washer Insert 5/8-11 UNC
16	132624	Pin, Axle, Large 5/8 x 1.55/1.54
17	128758	Shaft Assembly, Steering
18	57079	Washer, Thrust .515 x .750 x .033
19	124035X	Support, Shaft
20	126684X	Washer, Shim 1/4 x 5/8 x .062
21	STD551125	Washer
22	71100410	Screw Cap Socket Head Phos & Oil
23	127501	Shaft Assembly, Pittman
24	109816X	Nyliner, Snap-In
25	124036X	Bracket, Steering
26	126847X	Bushing, Link Drag
27	136874	Gear, Sector
28	19131416	Washer 13/32 x 7/8 x 16
29	17490612	Screw, Thdrol 3/8-16 x 3/4
30	STD561210	Pin Cotter 1/8 x 3/4
32	130465	Tie Rod
36	145207	Bushing, Steering
37	152927	Screw
38	126805X	Insert, Cap, Steering Wheel
39	100712K	Washer .53 x 2.25 x .160
40	STD541350	Nut
41	100711L	Adapter, Steering Wheel
42	140216	Column, Steering
43	121749X	Washer 25/32 x 1-1/4 x 16 Gauge
46	121232X	Cap, Spindle
47	6855M	Fitting, Grease
62	149682	Kit, Steering Assembly

NOTE: All component dimensions given in U.S. inches
1 inch = 25.4 mm

REPAIR PARTS

TRACTOR -- MODEL NUMBER 917.256611

ENGINE

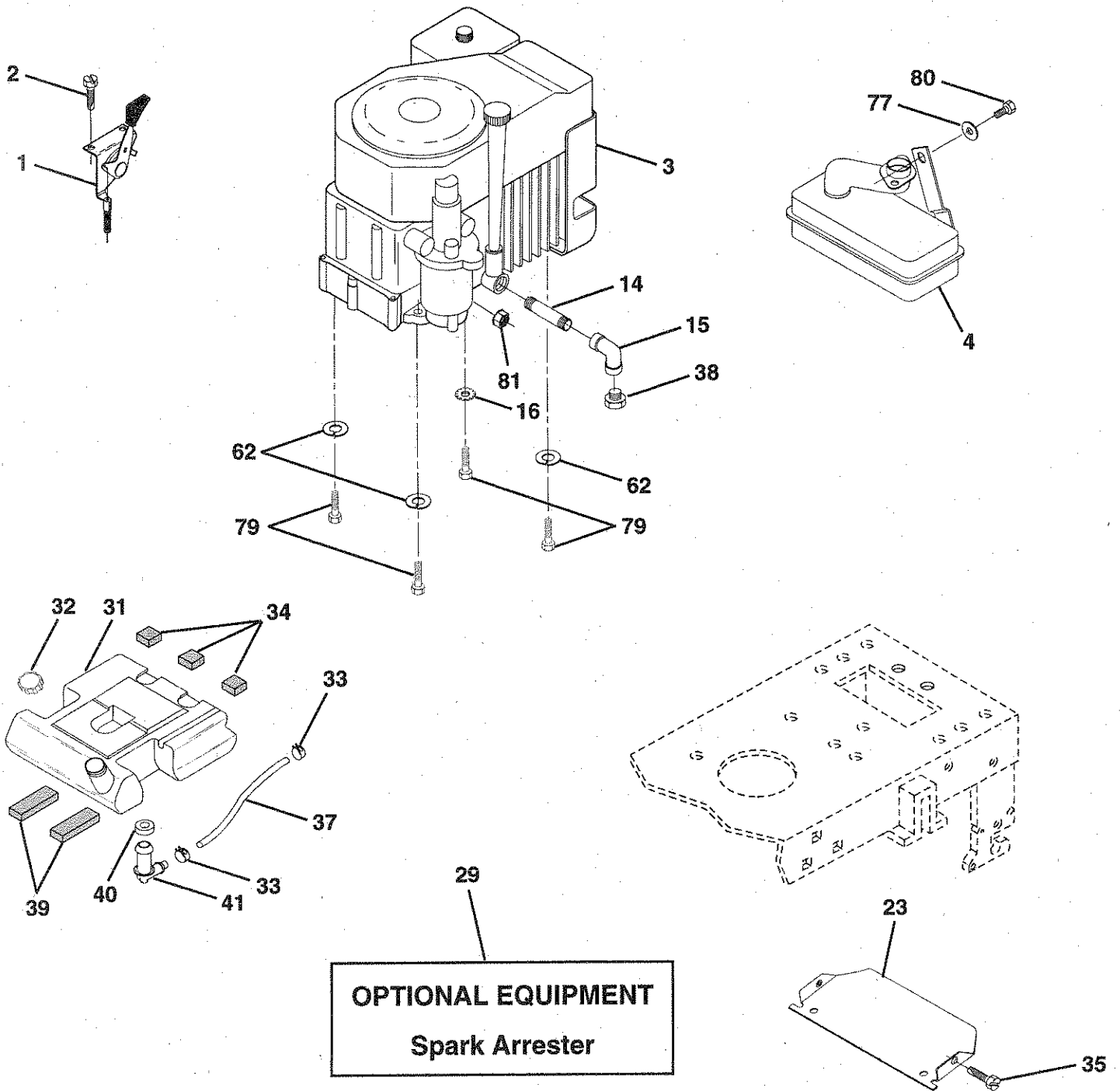

REPAIR PARTS

TRACTOR -- MODEL NUMBER 917.256611

ENGINE

KEY NO.	PART NO.	DESCRIPTION
1	134265	Control, Throttle
2	17720410	Screw, Hex Head, Thread Cutting 1/4-20 x 5/8
3	151063	Engine, Kohler Model No. CV15S, Type No. PS41525
4	137350	Muffler, Exhaust
14	13280328	Nipple, Pipe
15	13200300	Elbow, Standard 90°, 3/8-18 NPT
16	STD551231	Washer
23	150554	Shield, Browning
29	137180	Arrester, Spark
31	151346	Tank, Fuel
32	151296	Cap Assembly, Fuel
33	123487X	Clamp, Hose
34	106082X	Spacer, Pad 1 x 1 x 1
35	17490512	Screw Thdrol 5/16-18 x 3/4 TYT
37	8543R	Line, Fuel
38	-----	Plug, Oil Drain (Order From Engine Manufacturer)
39	109227X	Idler Pad 1.75 x .75 x .06
40	3645J	Bushing
41	139277	Stem, Fuel Tank
62	STD551131	Washer Lock 5/16
77	19101216	Washer 5/16 x 3/4 x 16 Ga.
79	M740108025	Screw Thdrol 3/8-16 x 1-1/4
80	74760508	Bolt Hex Hd 5/16-18 UNC x 1/2
81	128861	Nut Flange 1/4-20 UNC

NOTE: All component dimensions given in U.S. inches
1 inch = 25.4 mm

REPAIR PARTS

TRACTOR - - MODEL NUMBER 917.256611

DECALS

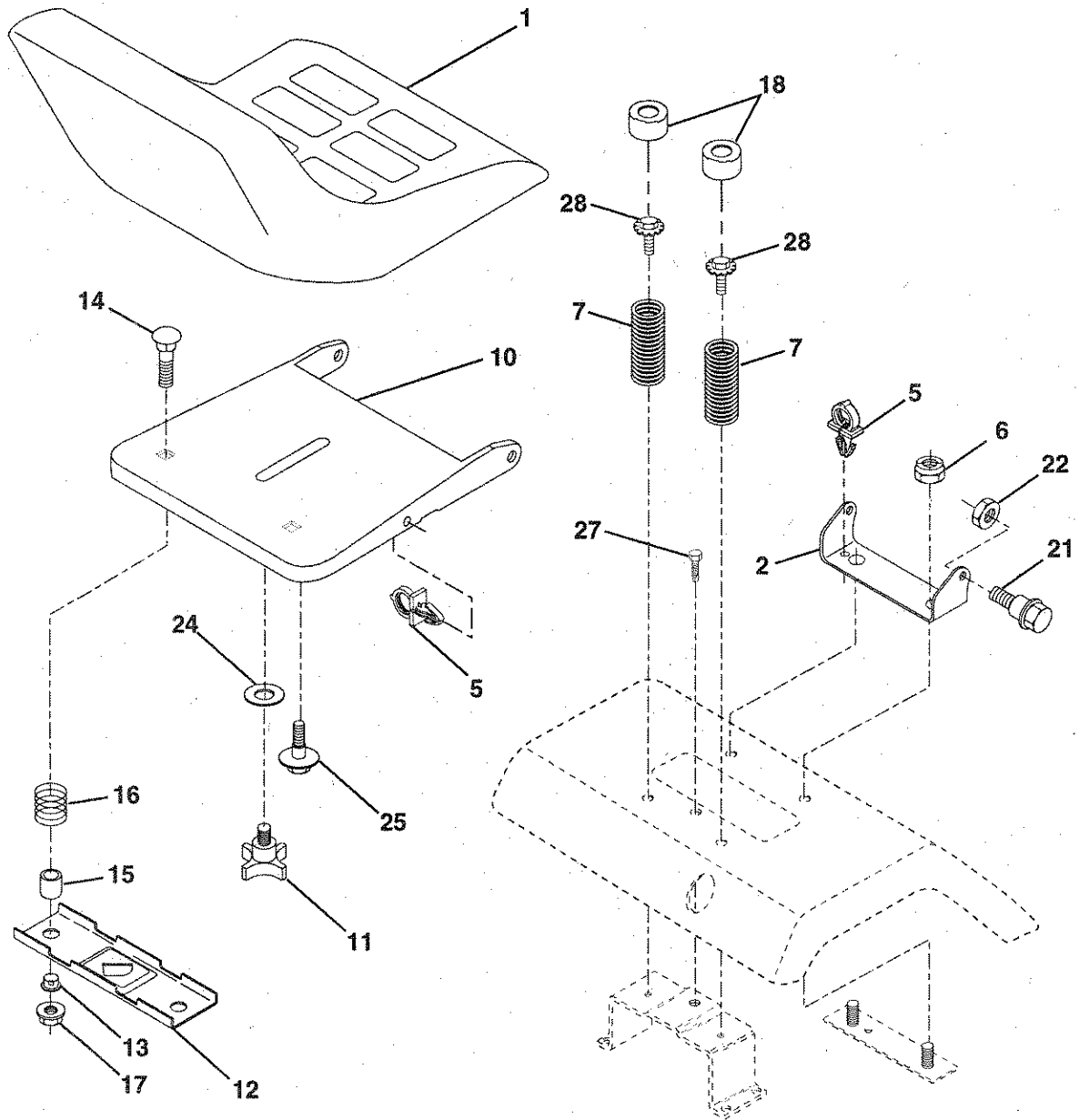

KEY NO.	PART NO.	DESCRIPTION
1	140123	Seat
2	140551	Bracket, Pivot, Seat
5	145006	Clip Push-In
6	STD541437	Nut
7	124181X	Spring, Seat
10	140552	Pan, Seat
11	120068X	Knob, Seat
12	121246X	Bracket, Switch Mounting
13	121248X	Bushing, Snap, Nylon
14	72050411	Bolt, Carriage 1/4-20 x 1-3/8
15	134300	Spacer, Split

KEY NO.	PART NO.	DESCRIPTION
16	121250X	Spring
17	123976X	Nut, Flangelock 1/4 Grade 5
18	124238X	Cap, Spring, Seat
21	153236	Bolt, Shoulder 5/16-18 UNC
22	STD541431	Nut
24	19171912	Washer 17/32 x 1-3/16 x 12 Gauge
25	127018X	Bolt, Shoulder 5/16-18 x .62
27	17490608	Screw Thdrol. 3/8-16 x 1/2
28	150176	Bolt 5/16-18 UNC x 3/4 W/Sems

NOTE: All component dimensions given in U.S. inches
1 inch = 25.4 mm

REPAIR PARTS

TRACTOR -- MODEL NUMBER 917.256611

SEAT ASSEMBLY

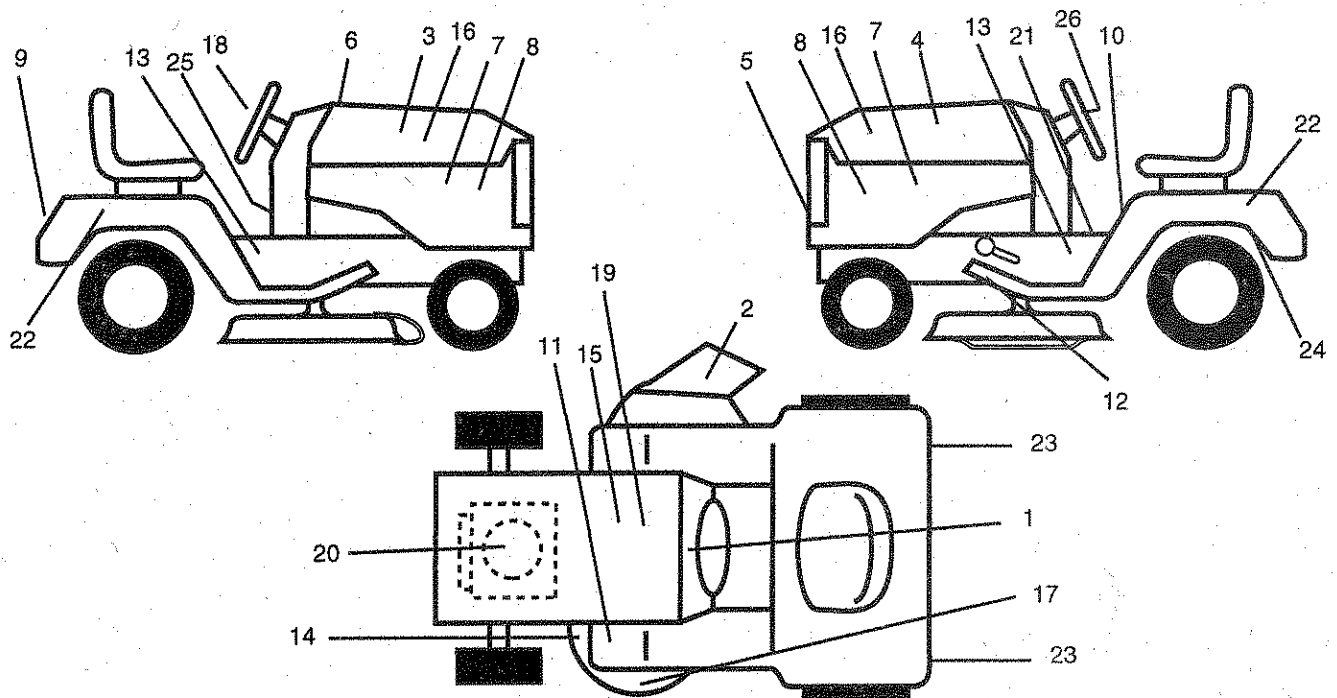

KEY NO.	PART NO.	DESCRIPTION
1	138955	Decal, Operating Instruction
2	151302	Decal, Mower, EZ3
3	146705	Decal, Hood, Craftsman, RH
4	146706	Decal, Hood, Craftsman, LH
5	151400	Decal, Grille
6	133644	Decal, Maintenance
7	138048	Decal, Side Panel
8	142241	Decal, Side Panel
9	146709	Decal, Fender, Craftsman
10	137537	Decal, Caution
11	4900J	Decal, Clutch/Brake
12	146046	Decal, V-Belt Drive Schematic
13	151401	Decal, Chassis
14	139346	Decal, V-Belt Schematic
15	149516	Decal, Battery Danger/Poison

KEY NO.	PART NO.	DESCRIPTION
16	151708	Decal, Ins. Hood
18	146710	Decal, Insert Strg
19	138047	Decal, Battery
20	12-113-55	Decal, Engine
21	140837	Decal, Brake Parking Saddle
22	149918	Decal, Fend Auto
23	106202X	Reflector, Taillight
24	142341	Decal, Drawbar
25	142336	Decal Sdl Cold/Start
26	150333	Decal, Line Hot Consumer Sears
--	138311	Decal, Handle Lift Height Adj.
--	145247	Fastener Pop-In Footrest
--	145245	Decal, Pad Footrest
--	154012	Manual, Owner's (Eng)
--	154013	Manual, Owners (Span)

WHEELS & TIRES

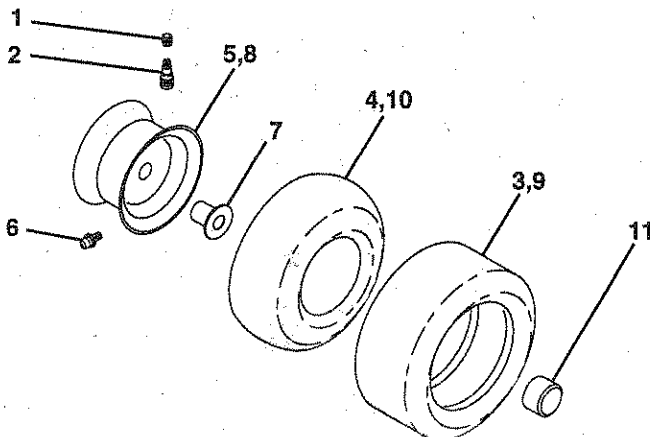

KEY NO.	PART NO.	DESCRIPTION
1	59192	Cap, Valve, Tire
2	65139	Stem, Valve
3	106222X	Tire, Front
4	59904	Tube, Front (Service Item Only)
5	106732X427	Rim Assembly, Front
6	278H	Fitting, Grease (Front Wheel Only)
7	9040H	Bearing, Flange (Front Wheel Only)
8	106108X427	Rim Assembly, Rear
9	122082X	Tire, Rear
10	7152J	Tube, Rear (Service Item Only)
11	104757X	Cap, Axle
--	144334	Sealant, Tire (10 oz. Tube)

NOTE: All component dimensions given in U.S. inches
1 inch = 25.4 mm

REPAIR PARTS

TRACTOR - - MODEL NUMBER 917.256611

MOWER LIFT

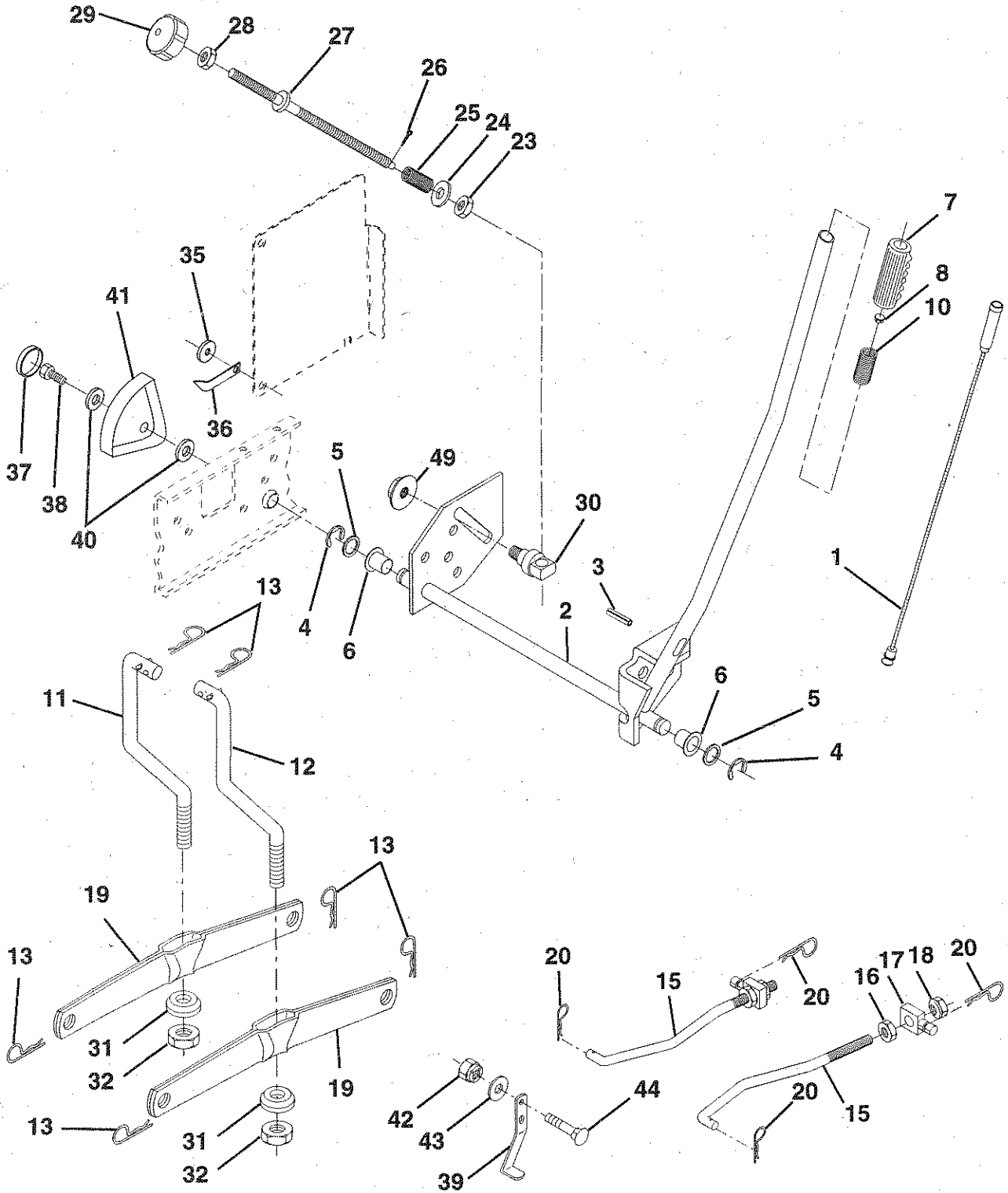

REPAIR PARTS

TRACTOR - - MODEL NUMBER 917.256611

MOWER LIFT

KEY NO.	PART NO.	DESCRIPTION
1	136971	Wire Asm., Inner w/plunger
2	136968	Shaft Asm Lift
3	138284	Pin Groove
4	12000002	E Ring #5133-62
5	19211621	Washer 21/32 X 1 X 21 Ga
6	120183X	Bearing Nylon
7	125631X	Grip Handle Fluted
8	122365X	Button, Plunger
10	122512X	Spring Cprsn
11	139865	Link Lift Lh
12	139866	Link Lift Rh
13	STD624008	Retainer Spring
15	127218	Link Front
16	73350800	Nut Jam Hex 1/2-13 Unc
17	130171	Trunnion Blk Zinc
18	73800800	Nut Lock W/Wsh 1/2-13 Unc
19	139868	Arm Suspension Rear
20	STD624008	Spring Retainer
23	110807X	Nut Special
24	19131016	Washer 13/32 X 5/8 X 16 Ga
25	137150	Spring"
26	76020308	Pin Cotter 3/32 x 1/2
27	137167	Rod Adjust Lift
28	73350600	Nut Hex Jam 3/8-16 Unc
29	138057	Knob Infinite 3/8-16 Unc Black
30	150233	Trunnion Infin. Height
31	140302	Bearing Pvt. Lift Spherical
32	73540600	Nut, Crownlock 3/8-24
35	120529X	Washer, Nylon .44 x .75 x .032
36	123933X505	Pointer, Height Indicator
37	123935X	Plug, Hole
38	17490512	Screw Thdrol 5/16-18 x 3/4
40	19112410	Washer 11/32 x 1-1/2 x 10 Gauge
41	123934X	Scale, Height Indicator
49	145212	Nut Hex Flange Lock

NOTE: All component dimensions given in U.S. inches
1 inch = 25.4 mm

REPAIR PARTS

TRACTOR -- MODEL NUMBER 917.256611

MOWER DECK

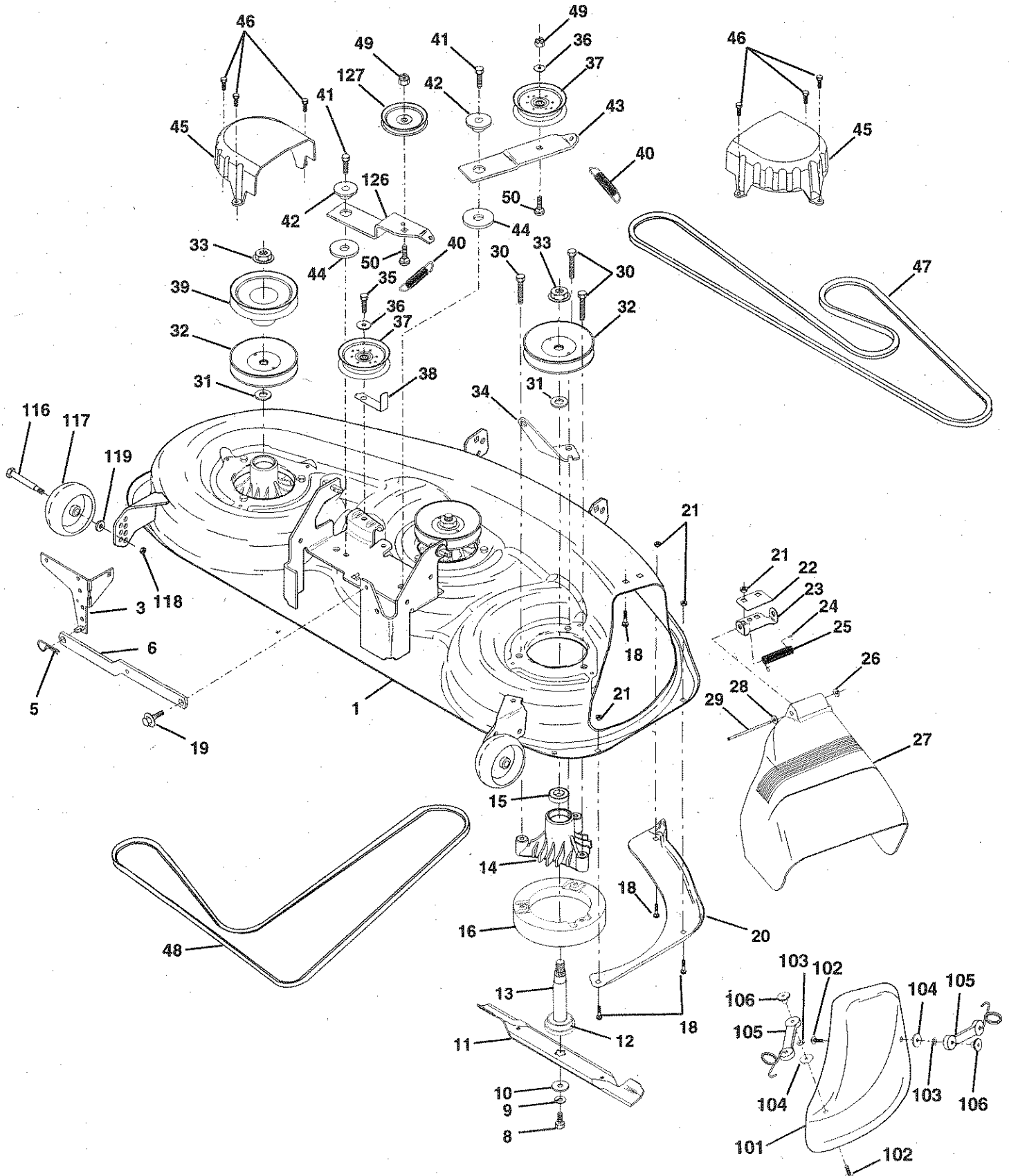

REPAIR PARTS

TRACTOR - - MODEL NUMBER 917.256611

MOWER DECK

KEY NO.	PART NO.	DESCRIPTION	KEY NO.	PART NO.	DESCRIPTION
1	153125	Mower Housing (Weldment)	38	137554	Keeper, Belt, Idler
3	138457	Bracket Asm., Sway Bar	39	144917	Pulley, Idler, Driven
5	STD624008	Retainer Spring	40	137273	Spring, Secondary 44/46/50 Vent
6	130832	Arm, Suspension, Rear (Sway Bar)	41	17490620	Screw, Thdroll 3/8-16 x 1-1/4 Tytt
8	850857	Bolt, Patched 3/8-24 x 1-1/4 Gr. 8	42	122052X	Spacer, Retainer
9	STD551137	Washer, Lock Hvy., Unplated 3/8	43	144949	Arm, Idler Secondary
10	140296	Washer, Hard Blade, Mower Vented	44	133943	Washer, Hardened
11	152443	Blade, 46" Mower Deck	45	145059	Cover, Mandrel Deck
12	129895	Bearing, Ball, Mandrel #6204	46	137729	Screw, Thdroll. 1/4-20 x 5/8
13	137553	Shaft Asm. w/Lower Bearing (Includes Key No. 12)	47	144959	V-Belt, Mower, Secondary
14	137152	Housing, Mandrel	48	148763	V-Belt, Mower, Primary
15	110485X	Bearing, Ball, Mandrel	49	STD541437	Nut, Crownlock 3/8-16 UNC
16	140329	Stripper, Mower Round	50	72110612	Bolt, Carriage 3/8-16 x 1-1/2 Gr. 5
18	72140505	Bolt, Carriage 5/16-18 x 5/8	101	145579	Cover, Mulching
19	132827	Bolt, Hex Head, Shoulder 5/16-18	102	71161010	Screw
20	145055	Baffle, Vortex Mower 46"	103	STD551110	Washer, Lock #10
21	STD541431	Nut, Crownlock 5/16-18 UNC	104	19061216	Washer
22	134753	Stiffener, Bracket	105	130758	Latch Asm. Bagger
23	131267	Bracket, Deflector	106	2029J	Nut, Weld
24	105304X	Cap, Sleeve	116	137644	Bolt, Shoulder
25	123713X	Spring, Torsion, Deflector	117	133957	Gauge Wheel, Wide
26	110452X	Nut, Push	118	73930600	Nut, Centerlock 3/8-16 UNC
27	145325	Shield, Deflector Mower	119	19121414	Washer 3/8 x 7/8 x 14 Ga.
28	19111016	Washer 11/32 x 5/8 x 16 Ga.	126	144948	Arm, Idler, Primary Deck 46"
29	131491	Rod, Hinge	127	146763	Pulley, Idler, V-Groove Dim. 4.25
30	138776	Screw, Hex Head, Thdroll	--	151775	Deck Complete (Std. Deck-Order separately mulcher plate and gauge wheel components Key Nos. 101-106 and 116-118)
31	129963	Washer, Spacer Mower Vented	--	143651	Mandrel Asm 44"/50" Service (Includes Key Nos. 8-10, 12-15, 31 and 33)
32	153531	Pulley, Mandrel			
33	137266	Nut, Flg. Top Lock Cntr. 9/16			
34	144945	Anchor, Spring Deck 46"			
35	17490628	Screw, Thdroll 3/8-16 x 1-3/4 Tytt			
36	STD551037	Washer 13/32 x 13/16 x 16 Ga.			
37	131494	Pulley, Idler, Flat			

NOTE: All component dimensions given in U.S. inches
1 inch = 25.4 mm

REPAIR PARTS

TRACTOR - - MODEL NUMBER 917.256611 HYDRO GEAR TRANSAXLE - MODEL NUMBER 310-0650

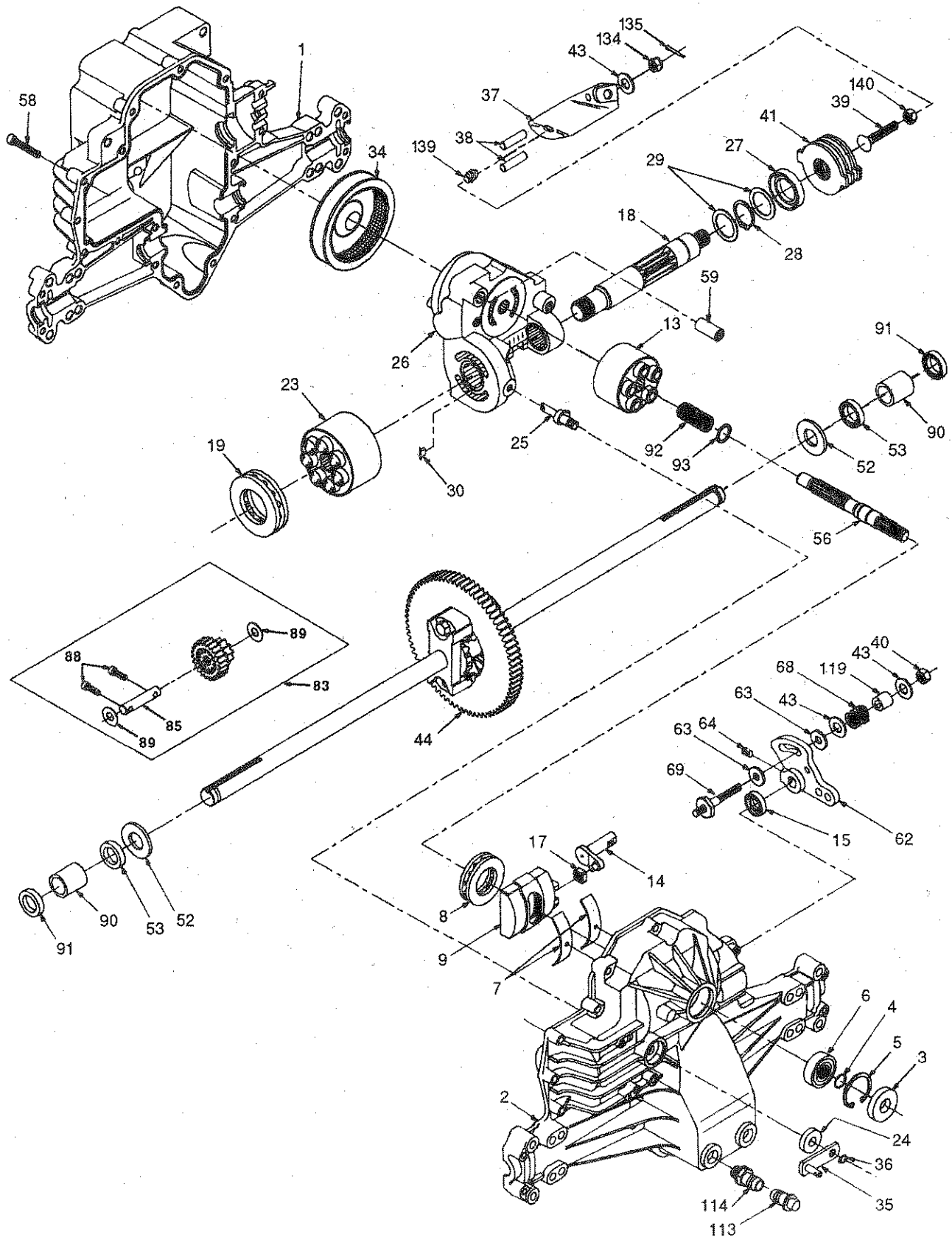

REPAIR PARTS

TRACTOR - - MODEL NUMBER 917.256611 HYDRO GEAR TRANSAXLE - MODEL NUMBER 310-0650

KEY PART NO. NO.	DESCRIPTION	KEY PART NO. NO.	DESCRIPTION
1 142930	Housing, Lower	43 142884	Washer 7/16 x 7/8 x .060
2 142931	Assembly, Upper Housing	44 150829	Differential Assembly
3 142932	Seal, Lip	52 142991	Washer 3/4 x 1.5 x .13
4 142928	Ring, Wire Retaining	53 142961	Seal .75 x 1.25 x .250
5 142933	Ring, Retaining	56 142963	Shaft, Input
6 142934	Bearing, Shaft Ball	58 142964	Bolt 1/4-20 x 1.38
7 142935	Bearing, Cradle	59 142965	Pin .5 OD x .43 ID x .750
8 150771	Bearing, Thrust 30 x 52 x 13	62 142966	Arm, Control
9 142937	Swashplate, Variable	63 142967	Puck, Dampener
13 142938	Block, Cylinder Assembly	64 142920	Set Screw
14 142939	Arm, Trunnion	68 142969	Spring
15 142940	Seal, Lip	69 144610	Stud 5/16-24
17 142941	Guide, Slot	83 142971	Jackshaft Assembly
18 150772	Shaft, Motor	85 150806	Jackshaft
19 150773	Bearing, Thrust 42 x 68 x 16	88 142973	Screw, Cap
23 142944	Block, Cylinder Assembly	89 142974	Washer 7/16 x 1 x 1/2
24 142945	Seal, Lip 10 x 25 x 7	90 142975	Sleeve Bearing
25 142946	Actuator, Bypass	91 142976	Seal, Wiper
26 150774	Center Section Assembly Kit	92 142977	Spring, Block
27 142948	Seal, Lip 26 x 42 x 8	93 142978	Washer, Block Thrust
28 142949	Ring, Retaining	113 142917	Cap, Vent Assembly
29 142950	Washer 26 x 35 x 1	114 142918	Fitting, O-Ring Assembly
34 142951	Oil Filter Element	119 142980	Spacer
35 142952	Arm, Bypass	134 144607	Nut, Castle 5/16-24
36 142953	Ring, Retaining	135 144608	Pin, Cotter
37 142954	Arm, Actuating	139 150775	Spring, Compression
38 142955	Pin, Actuating	140 150776	Nut, Hex 5/16-24
39 150777	Bolt 5/16-24 x 1-3/4		
40 150778	Locknut, Hex 5/16-24 UNJC		
41 142958	Brake Rotor/Stator Kit		

NOTE: All component dimensions given in U.S. inches
1 inch = 25.4 mm

REPAIR PARTS

TRACTOR - - MODEL NUMBER 917.256611

KOHLER ENGINE - MODEL NUMBER CV15S, TYPE NUMBER PS41525

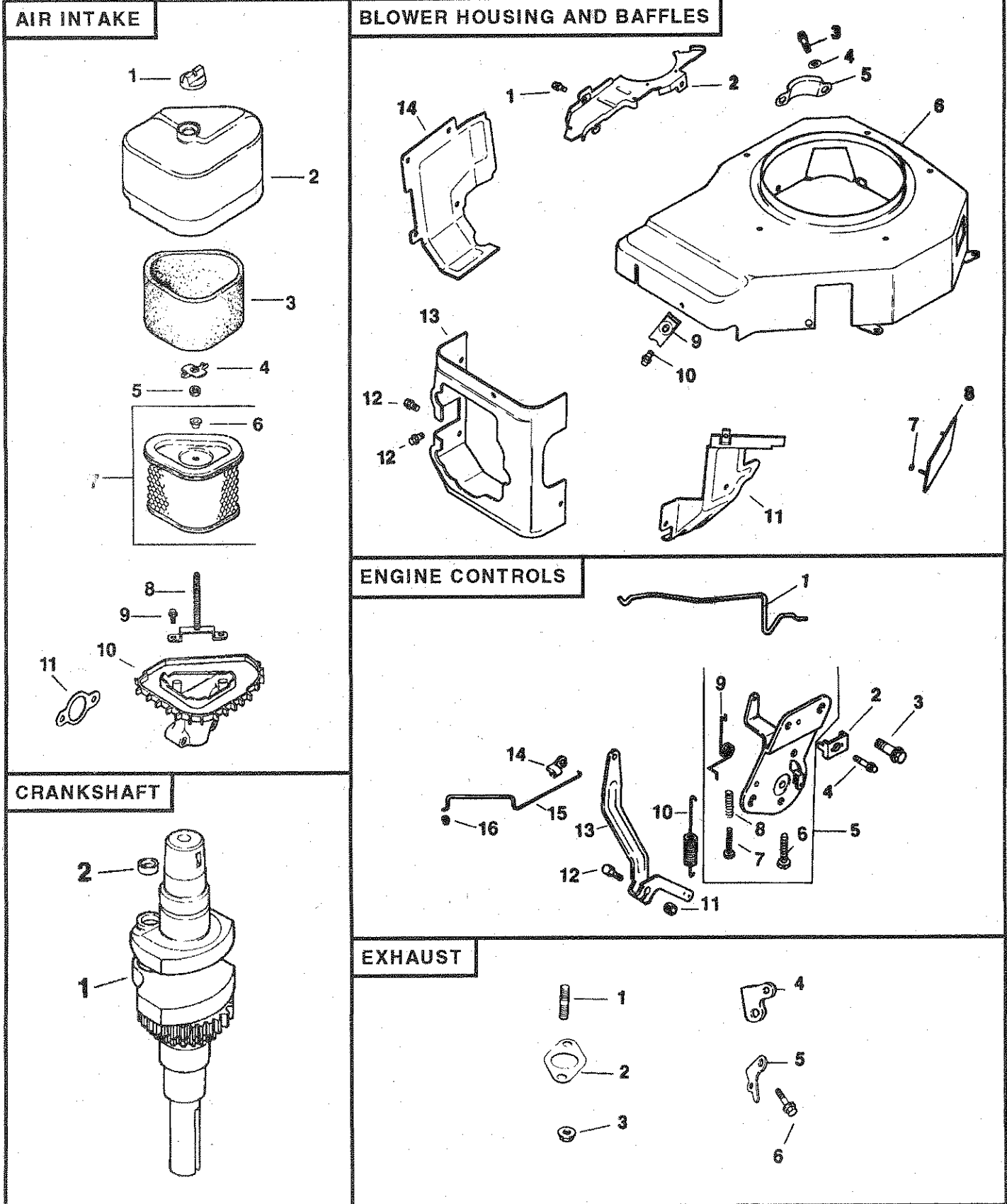

REPAIR PARTS

TRACTOR - - MODEL NUMBER 917.256611

KOHLER ENGINE - MODEL NUMBER CV15S, TYPE NUMBER PS41525

AIR INTAKE

KEY PART NO.	PART NO.	DESCRIPTION
1	25 341 02	Knob, Air Cleaner Cover
2	12 096 24	Cover, Air Cleaner
3	12 083 08	Precleaner Element
4	12 100 01	Wing Nut
5	X-25-63	Washer, Plain 1/4
6	12 313 04	Grommet
7	12 083 05	Element, Air Cleaner (Includes #6)
8	12 072 03	Stud, Mounting Plate
9	12 086 01	Screw, Mounting Plate Stud (2)
10	12 094 12	Base, Air Cleaner (Includes Key Numbers 9 and 10)
11	12 041 02	Gasket, Air Cleaner

NOT ILLUSTRATED

--	12 113 53	Decal, Air Cleaner
----	-----------	--------------------

CRANKSHAFT

KEY PART NO.	PART NO.	DESCRIPTION
1	12 014 37	Crankshaft
2	12 139 01	Plug, Cup

BLOWER HOUSING AND BAFFLES

KEY PART NO.	PART NO.	DESCRIPTION
1	M-0545010	Screw, Mounting M5 x 0.8 x 10 (13)
2	12 146 07	Plate, Blower Housing
3	M-0645020	Screw, Hex Flange M6 x 1.0 x 20
4	220534	Washer, Plain 5/16 (2)
5	24 096 05	Cover, Pinion
6	12 027 32	Housing, Blower
7	12 141 01	Ring, Retainer (2)
8	12 096 28	Cover
9	25 154 02	Clip, Mounting (3)
10	SM-0545020	Screw, Hex Flange M5 x .8 x 20 (3)
11	12 063 05	Baffle, Intake Side
12	M-0645016	Screw, Hex Flange M6 x 1 x 16 (2)
13	12 063 08	Baffle, Cylinder Head
14	12 063 01	Baffle, Cylinder

NOT ILLUSTRATED

--	12 113 64	Decal, Horsepower
----	-----------	-------------------

ENGINE CONTROLS

KEY PART NO.	PART NO.	DESCRIPTION
1	12 079 07	Linkage, Choke
2	12 237 01	Clamp, Cable
3	SM-0645016	Screw, Hex Head M6 x 1.0 x 16 (2)
4	SM-0545016	Screw, Cable Clamp M5 x .8 x 16
5	12 536 01	Control, Speed Assembly (Includes Key Numbers 6 through 8)
6	M-0443020	Screw, Pan Head M4 x 0.7 x 20
7	SM-0443025	Screw, Pan Head M4 x 0.7 x 25
8	12 089 11	Spring, Choke Adjust
9	12 089 23	Spring, Choke Return
10	12 089 24	Spring, Governor
11	M-0641060	Nut, Governor Arm M6 x 1.0
12	SM-0642025	Screw, Governor Arm M6 x 1.0 x 25
13	12 090 05	Lever, Governor
14	25 158 11	Bushing
15	12 079 01	Linkage, Throttle
16	25 158 08	Bushing

EXHAUST

KEY PART NO.	PART NO.	DESCRIPTION
1	M-0829033	Stud, Exhaust Manifold M8 x 1.25 x 20 (2)
2	12 041 03	Gasket, Exhaust Manifold
3	M-0841080	Nut, Muffler Mounting M8 x 1.25 (2)
4	12 126 11	Bracket, Muffler
5	12 445 06	Strap, Lifting
6	M-0645025	Screw, Lifting Strap M6 x 1.0 x 25 (2)

NOT ILLUSTRATED

KEY PART NO.	PART NO.	DESCRIPTION
--	12 522 18	Short Block
--	12 755 59	Gasket Set

RPM Settings: Low Speed: 1500-2000
High Speed: 3200-3400

NOTE: All component dimensions given in U.S. inches
1 inch = 25.4 mm

REPAIR PARTS

TRACTOR - - MODEL NUMBER 917.256611

KOHLER ENGINE - MODEL NUMBER CV15S, TYPE NUMBER PS41525

FUEL SYSTEM

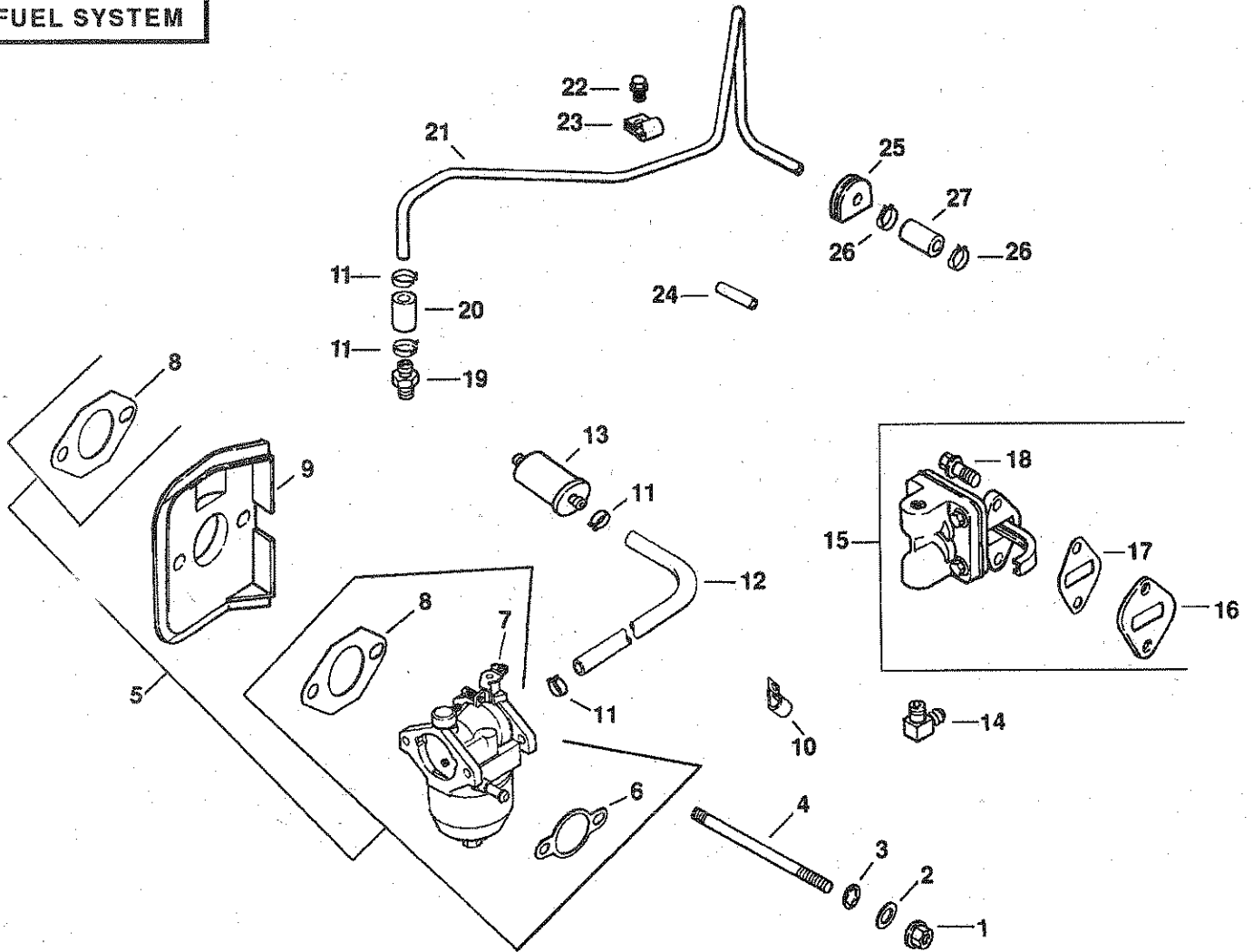

CYLINDER HEAD, VALVE AND BREATHER

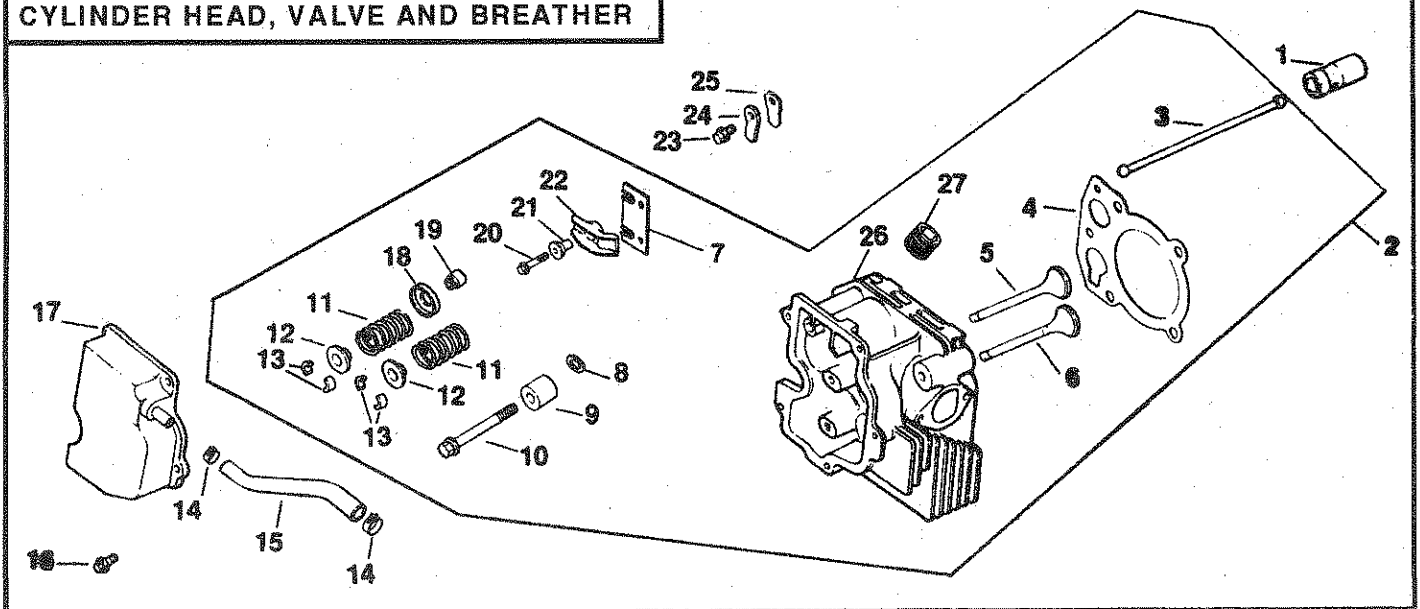

REPAIR PARTS

TRACTOR - - MODEL NUMBER 917.256611

KOHLER ENGINE - MODEL NUMBER CV15S, TYPE NUMBER PS41525

FUEL SYSTEM

KEY NO.	PART NO.	DESCRIPTION
1	M-0641060	Nut, Carburetor M6 x 1.0 (2)
2	X-25-63	Washer, Plain 1/4
3	X-22-11	Washer, Internal Tooth 1/4
4	M-0629122	Stud, Carburetor M6 x 1.0 x 110 (2)
5	12 853 68	Kit, Carburetor (Includes #6 thru 8)
6	12 041 02	Gasket, Air Cleaner
7	12 053 68	Carburetor Assembly (For Information Only - Not Available Separately)
8	12 041 01	Gasket, Carburetor (2)
9	12 265 04	Deflector, Heat
10	47 154 01	Clip, Cable
11	X-426-9	Clamp, Hose (2)
12	52 353 22	Line, Fuel, 12"
13	25 050 02	Filter, Fuel
14	25 155 02	Connector, Hose, 90°
15	12 559 01	Kit, Fuel Pump with Gaskets (Includes Key Numbers 16 thru 18)
16	12 112 05	Spacer, Fuel Pump
17	25 041 09	Gasket, Fuel Pump
18	M-0645020	Screw, Hex Flange M6 x 1 x 20 (2)
19	X-380-1	Connector, Straight Hose
20	12 353 01	Line, Fuel, 2-1/4"
21	12 123 19	Line, Fuel, Metal
22	M-0545010	Screw, Hex Flange M5 x 0.8 x 10
23	12 154 01	Clamp, Fuel Line
24	12 431 01	Sleeve, Insulating
25	12 313 01	Grommet, Fuel Line
26	25 237 02	Clamp, Hose (2)
27	12 353 10	Line, Fuel, 2-1/2"
NOT ILLUSTRATED		
--	12 041 01	Gasket, Carburetor
--	12 518 05	Lead, Solenoid, Black, 5", 14 Gauge, Uninsulated Push-On Tabs

CYLINDER HEAD, VALVE AND BREATHER

KEY NO.	PART NO.	DESCRIPTION
1	12 351 01	Lifter, Valve (2)
2	12 755 60	Kit, Cylinder Head
3	12 411 01	Rod, Push (2)
4	12 041 10	Gasket, Cylinder Head
5	12 017 01	Valve, Intake, Standard Size
	12 017 02	Valve, Intake, .25" Oversize
6	12 016 01	Valve, Exhaust, Standard
	12 016 02	Valve, Exhaust, .25" Oversize
7	12 146 13	Plate, Guide
8	12 468 05	Washer, Plain 13/32
9	12 112 13	Spacer, Head Bolt Exhaust Port
10	12 086 15	Screw, Cylinder Head M10 x 1.5 x 80 (5)
11	12 089 01	Spring, Valve (2)
12	12 173 01	Cap, Valve Spring (2)
13	12 755 03	Kit, Retainer (2)
14	X-426-9	Clamp, Hose (2)
15	12 326 03	Hose, Breather
16	M-0645020	Screw, Valve Cover M6 x 1.0 x 20 (5)
17	12 096 07	Cover, Valve with Nipple
18	235011	Retainer, Spring
19	24 032 05	Seal, Valve Stem
20	M-0640034	Screw, Rocker Arm M6 x 1 x 34 (2)
21	24 194 01	Pivot, Rocker Arm (2)
22	24 186 03	Arm, Rocker (2)
23	M-0545010	Screw, Breather Reed Retainer M5 x 0.8 x 10
24	12 018 01	Retainer, Breather Reed
25	24 402 02	Reed, Breather
26	12 318 09	Head, Cylinder
27	X-75-23	Plug, Pipe, Allen Head 1/8

NOTE: All component dimensions given in U.S. inches
1 inch = 25.4 mm

REPAIR PARTS

TRACTOR -- MODEL NUMBER 917.256611

KOHLER ENGINE - MODEL NUMBER CV15S, TYPE NUMBER PS41525

IGNITION / ELECTRICAL

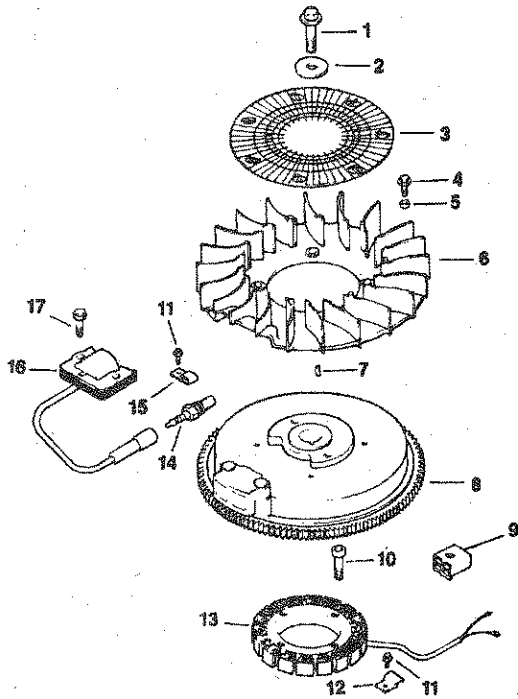

OIL PAN / LUBRICATION

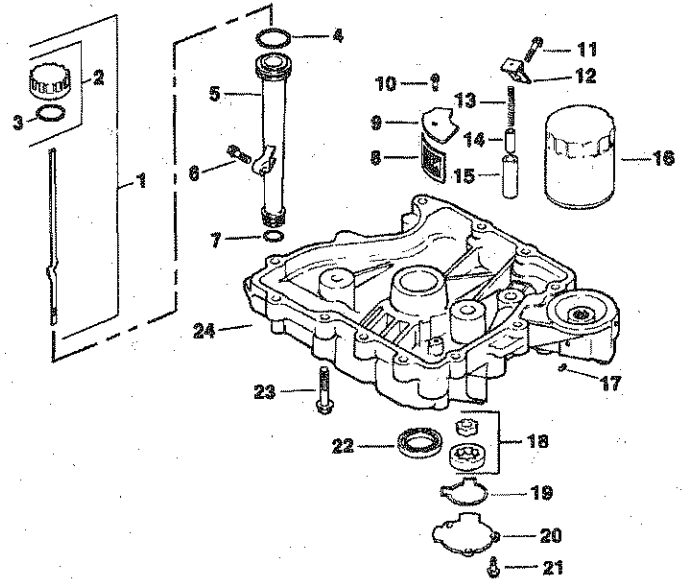

CRANKCASE

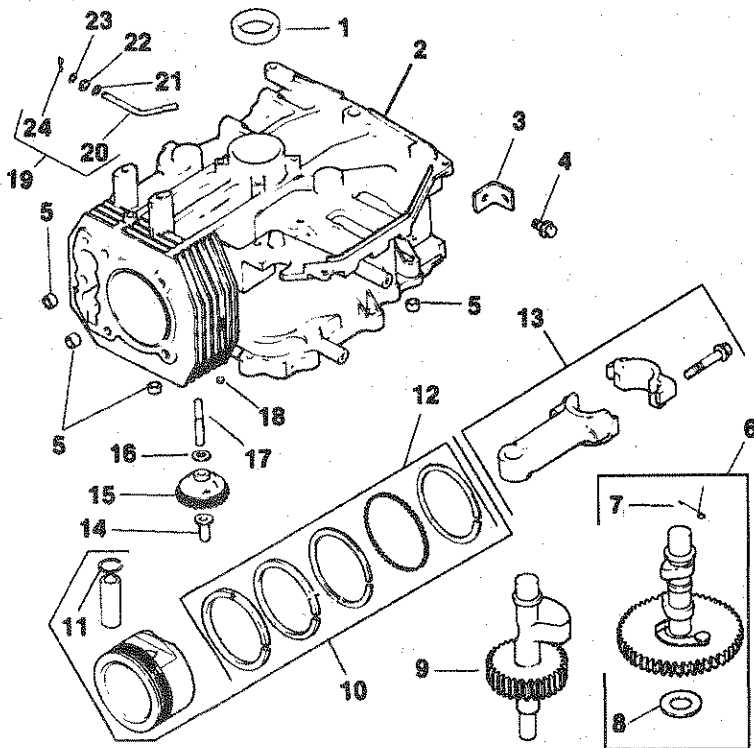

STARTING SYSTEM

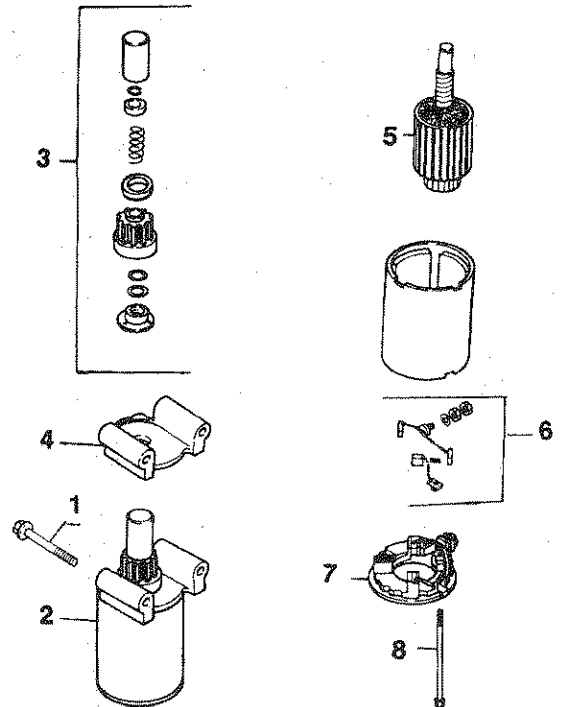

REPAIR PARTS

TRACTOR - - MODEL NUMBER 917.256611

KOHLER ENGINE - MODEL NUMBER CV15S, TYPE NUMBER PS41525

IGNITION / ELECTRICAL

KEY PART NO.	PART NO.	DESCRIPTION
1	12 086 14	Screw, Flywheel M10 x 1.5 x 45.8
2	12 468 03	Washer, Flywheel
3	12 162 03	Screen, Grass
4	M-0639016	Screw, Fan M6 x 1 x 13 (4)
5	12 112 01	Spacer, Fan (4)
6	12 157 02	Fan
7	X-42-15	Key
8	12 025 25	Flywheel Assembly
9	41 155 02	Connector (4 Contact)
10	M-0548025	Screw, Stator Mounting M5 x 0.8 x 25 (2)
11	M-0545010	Screw, Stator Harness Clip M5 x 0.8 x 10 (2)
12	12 154 02	Clip, Stator Harness
13	12 085 03	Stator Assembly
14	12 132 02	Spark Plug
15	X-728-1	Clip, Cable
16	12 584 01	Module, Ignition
17	SM-0545020	Screw, Ignition Module M5 x 0.8 x 20 (2)

NOT ILLUSTRATED

--	12 518 01	Lead, White, Ground To Kill (19", 18 Gauge, Fully Insulated Push-on Tab and Uninsulated Push-on Tab Terminals)
----	-----------	--

OIL PAN / LUBRICATION

KEY PART NO.	PART NO.	DESCRIPTION
1	12 038 01	Dipstick Assembly (Includes Key Numbers 2 and 3)
2	25 755 13	Kit, Oil Fill Cap (Includes Key #3)
3	12 153 03	O-Ring, Dipstick
4	12 153 02	O-Ring, Upper Oil Fill Tube
5	12 123 04	Tube, Oil Fill
6	SM-0545020	Screw, Oil Fill Tube M5 x 0.8 x 20
7	12 153 01	O-Ring, Lower Oil Fill Tube
8	25 162 07	Screen, Oil Pick-up
9	12 096 03	Cover, Oil Pick-up Screen
10	M-0545016	Screw, Screen Cover
11	M-1039025	Screw, Oil Pump Relief Valve Bracket M10 x 1.5 x 25
12	12 126 02	Bracket, Oil Pump Relief Valve
13	12 089 03	Spring, Oil Pump Relief Valve
14	12 462 01	Piston, Oil Pump Relief Valve
15	12 208 01	Body, Oil Pump Relief Valve
16	12 050 01	Filter, Oil
17	X-75-10	Plug, Square Head, Solid 3/8 NPTF
18	12 393 01	Oil Pump Assembly
19	12 032 04	O-Ring, Oil Pump Cover
20	12 096 02	Cover, Oil Pump
21	M-0545016	Screw, Oil Pump Cover M5 x 0.8 x 16 (3)
22	12 032 03	Seal, Oil (P.T.O. End)
23	SM-0839045	Screw, Oil Pan M8 x 1.25 x 45 (12)
24	12 199 30	Pan, Oil

CRANKCASE

KEY PART NO.	PART NO.	DESCRIPTION
1	12 032 03	Seal, Crankshaft
2	12 522 18	Block, Cylinder (Use Short Block)
3	12 445 02	Strap, Lifting
4	M-0839025	Screw, Lifting Strap M8 x 1.25 x 22
5	12 380 03	Dowel, Locating (4)
6	12 755 49	Kit, Camshaft (Includes Key #7 & 8)
7	12 089 18	Spring, Actuating
8	12 422 08	Shim, Camshaft, Blue
	12 422 09	Shim, Camshaft, Red (A.R.)
	12 422 10	Shim, Camshaft, Yellow (A.R.)
	12 422 11	Shim, Camshaft, Green (A.R.)
	12 422 12	Shim, Camshaft, Grey (A.R.)
	12 422 13	Shim, Camshaft, Black (A.R.)
	12 422 07	Shim, Camshaft, White (A.R.)
9	12 144 19	Shaft, Balance
10	12 874 07	Piston w/Ring Set, Standard
	12 874 08	Piston w/Ring Set .25" Oversize
	12 874 09	Piston w/Ring Set .50" Oversize
11	12 018 02	Retainer, Piston Pin (2)
12	12 108 07	Ring Set, Standard
	12 108 08	Ring Set .25" Oversize
	12 108 09	Ring Set .50" Oversize
13	12 067 05	Connecting Rod, Standard
	12 067 06	Connecting Rod .25" Oversize
14	12 380 01	Pin, Governor Regulating
15	12 043 05	Gear, Governor Assembly
16	M-0631005	Washer, Governor Gear Thrust
17	12 144 02	Shaft, Governor Gear
18	52 139 09	Plug, Cup
19	12 755 64	Kit, Shaft, Governor Cross, with Clip (Includes Key #20 and 24)
20	12 144 24	Shaft, Governor Cross
21	X-25-102	Washer, Plain 1/4
22	12 032 01	Seal, Governor Cross Shaft
23	SM-0631015	Washer, Governor Shaft
24	12 154 05	Clip, Hitch Pin

STARTING SYSTEM

KEY PART NO.	PART NO.	DESCRIPTION
1	M-0839070	Screw, Starter M8 x 1.25 x 70 (2)
2	12 098 03	Starter Assembly (Includes Key Numbers 3 thru 8)
3	12 755 54	Kit, Drive End
4	12 227 06	Cap, Drive End
5	45 170 03	Armature
6	82 755 28	Kit, Brush and Spring
7	12 227 11	End Cap, Commutator
8	12 086 25	Screw, Hex Flange 1/4-20 x 4-5/8 (2)

NOTE: All component dimensions given in U.S. inches
1 inch = 25.4 mm

SERVICE NOTES

SERVICE NOTES

SERVICE NOTES

SUGGESTED GUIDE FOR SIGHTING SLOPES FOR SAFE OPERATION

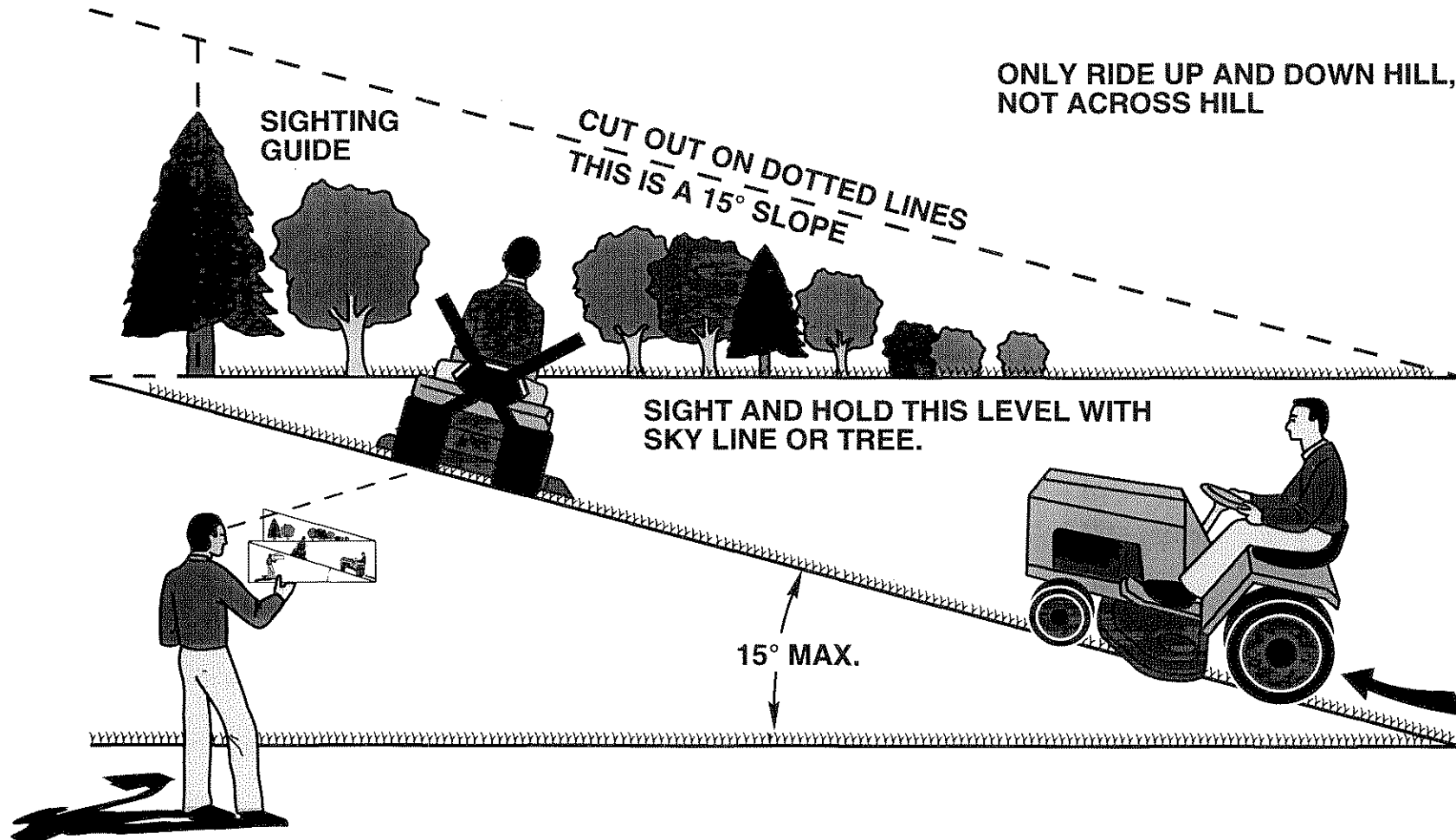

Operate your Tractor up and down the face of slopes (not greater than 15°), never across the face. Make turns gradually to prevent tipping or loss of control. Exercise extreme caution when changing direction on slopes.

SEARS

**OWNER'S
MANUAL**

**MODEL NO.
917.256611**

**IF YOU NEED
REPAIR SERVICE
OR PARTS:**

FOR REPAIR SERVICE, CALL
THIS TOLL FREE NUMBER:

1-800-4-REPAIR
(1-800-473-7247)

FOR REPLACEMENT PARTS
INFORMATION AND
ORDERING, CALL THIS
TOLL FREE NUMBER:

1-800-FON-PART
(1-800-366-7278)

FOR CONSUMER ASSISTANCE
HOT LINE, CALL THIS
TOLL FREE NUMBER:

1-800-659-5917

CRAFTSMAN®

**15.5 HP
ELECTRIC START
46" MOWER
AUTOMATIC (HYDROSTATIC)
DRIVE
LAWN TRACTOR**

Each tractor has its own model number. Each engine has its own model number.

The model number for your tractor will be found on the model plate located under the seat.

The model number for your engine will be found on the blower housing of the engine.

All parts listed herein may be ordered from any Sears, Roebuck and Co. Service Center/Department and most Retail Stores.

**WHEN ORDERING REPAIR PARTS, ALWAYS GIVE THE
FOLLOWING INFORMATION:**

- PRODUCT - TRACTOR
- MODEL NUMBER - 917.256611
- ENGINE MODEL NO. - CV15S-P41525
- PART NUMBER
- PART DESCRIPTION

Your Sears merchandise has added value when you consider Sears has service units nationwide staffed with Sears trained technicians... professional technicians specifically trained to insure that we meet our pledge to you, we service what we sell.