

# CRAFTSMAN®

## 6.5 Horsepower HIGHWHEEL WEEDTRIMMER

MODEL NO.  
536.773510

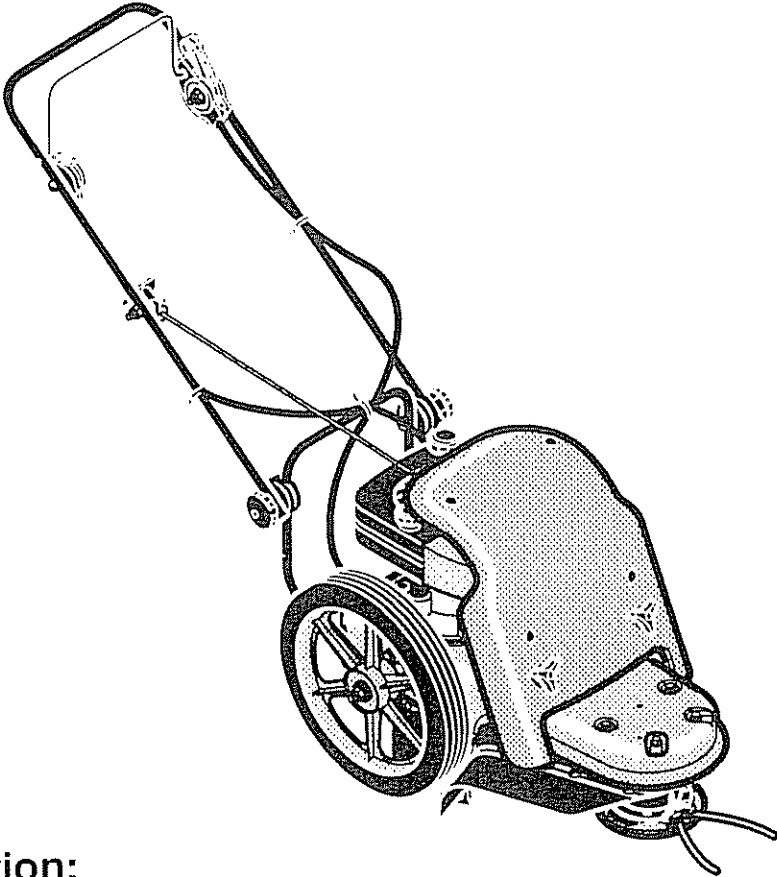

### Caution:

Read and follow all Safety Rules  
and Operating Instructions before  
first use of this product.

SEARS, ROEBUCK AND CO., Hoffman Estates, IL 60179 U.S.A.

712490 02/17/99

SAFETY

ASSEMBLY

OPERATION

MAINTENANCE

PARTS LIST

ESPAÑOL

## TABLE OF CONTENTS

WARRANTY STATEMENT .....	2	TROUBLE SHOOTING CHART ..	20
SAFETY RULES .....	3	SLOPE GUIDE .....	22
INTERNATIONAL SYMBOLS .....	5	REPAIR PARTS .....	23
ASSEMBLY .....	6	ENGINE REPAIR PARTS .....	28
OPERATION .....	9	SPANISH (ESPAÑOL) .....	34
MAINTENANCE .....	13	PARTS ORDERING/SERVICE ...	56
SERVICE AND ADJUSTMENT ...	16		

### WARRANTY STATEMENT

#### LIMITED TWO-YEAR WARRANTY ON CRAFTSMAN WEEDTRIMMER

For two years from the date of purchase, when this Craftsman Weedtrimmer is maintained, lubricated, and tuned up according to the operating and maintenance instructions in the owner's manual, Craftsman will repair, free of charge, any defect in material or workmanship.

If this Craftsman Weedtrimmer is used for commercial or rental purposes, this warranty applies for only 90 days from the date of purchase.

This warranty does not cover the following:

- Expendable items which become worn during normal use, such as spark plugs, etc.
- Repair necessary because of operator abuse or negligence, including bent crankshafts and the failure to maintain the equipment according to the instructions contained in the owner's manual.

**WARRANTY SERVICE IS AVAILABLE BY RETURNING THE CRAFTSMAN WEEDTRIMMER TO THE NEAREST CRAFTSMAN SERVICE CENTER/DEPARTMENT IN THE UNITED STATES. THIS WARRANTY APPLIES ONLY WHILE THIS PRODUCT IS IN USE IN THE UNITED STATES.**

This warranty gives you specific legal rights, and you may also have other rights which may vary from state to state.

Sears, Roebuck and Co., D817WA, Hoffman Estates, IL 60179

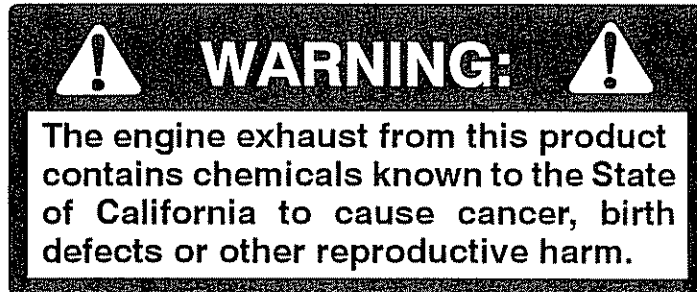

**IMPORTANT:** This unit is equipped with an internal combustion engine and must not be used on or near any unimproved forest-covered, brush-covered or grass-covered land unless the engine's exhaust system is equipped with a spark arrester meeting applicable local or state laws (if any). If a spark arrester is used, it must be maintained in effective working order by the operator.

In the State of California the above is required by law (Section 4442 of the California Public Resources Code). Other states may have similar laws. Federal laws apply on federal lands. See an Authorized Service Center for a spark arrester for the muffler.

# SAFETY RULES

## Safe Operation Practices for Trimmer.



**WARNING:** Look for this symbol to point out important safety precautions. It means: "Attention! Become Alert! Your Safety Is Involved."

### I. General Operation

- 1 Read, understand, and follow all instructions on the machine and in the manual(s). Be thoroughly familiar with the controls and the proper use of the trimmer before starting.
- 2 Familiarize yourself with all of the safety and operating decals on this equipment and on any of its attachments or accessories.
- 3 Do not put hands or feet near or under rotating parts.
- 4 Only allow responsible individuals, who are familiar with the instructions, to operate the trimmer.
- 5 Inspect the area where the trimmer is to be used. Your equipment can propel small objects at high speed causing personal injury or property damage. Stay away from breakable objects, such as house windows, auto glass, greenhouses, etc.
- 6 Keep the area of operation clear of all persons, particularly small children, and pets.
- 7 Wear appropriate clothing such as a long-sleeved shirt or jacket. Also wear long trousers or slacks. Do not wear shorts.
- 8 Do not wear loose clothing which could get caught in this equipment.
- 9 Always wear safety goggles or safety glasses with side shields when operating trimmer to protect your eyes from foreign objects which can be thrown from the unit.
- 10 Always wear work gloves and sturdy footwear. Leather work shoes or short boots work well for most people. These will protect the operator's ankles and shins from small sticks, splinters, and other debris, and improve traction.
- 11 It is advisable to wear protective headgear to prevent the possibility of being struck by small flying particles, or being struck by low hanging branches, twigs, or other objects which may be unnoticed by the operator.
- 12 Do not operate the trimmer without proper guards or other safety protective devices in place.
- 13 Use this equipment for its intended purpose only.
- 14 See manufacturer's instructions for proper operation and installation of accessories.

- Only use accessories approved by the manufacturer.
- 15 Operate only in daylight or good artificial light.
  - 16 Do not operate the trimmer while under the influence of alcohol, drugs or other medication which can cause drowsiness or affect your ability to operate this machine safely.
  - 17 Never operate trimmer in wet grass. Always be sure of your footing; keep a firm hold on the handle and walk; never run.
  - 18 Before each use, inspect the throttle control lever and cable. Make sure that the cable is free and that the lever is not damaged. Also check the cable linkage running to the carburetor for kinks, loose fittings, and obstructions. Verify that the control bail is working properly.
  - 19 Stop the rotating trimmer head when crossing gravel drives, walks, or roads. Wait for the cutting lines to stop rotating.
  - 20 Watch for traffic when operating near, or when crossing roads.
  - 21 Stop the engine (motor) whenever you leave the equipment, before cleaning, repairing or inspecting the unit, be sure the trimmer head and all moving parts have stopped. Let the engine cool, disconnect the spark plug wire and move it away from the spark plug.
  - 22 If the equipment should start to vibrate abnormally, stop the engine (motor), disconnect the spark plug wire and prevent it from touching the spark plug. Check immediately for the cause. Vibration is generally a warning of trouble.
  - 23 After striking a foreign object, stop the engine (motor). Remove the wire from the spark plug. Inspect the trimmer for damage. If damaged, repair before starting and operating the trimmer.
  - 24 Never leave the trimmer unattended when the engine is running. Remove the wire from the spark plug.
  - 25 Regularly inspect the trimmer. Make sure parts are not bent, damaged or loose.

### II. Slope Operation

Slopes are a major factor related to slip and fall accidents which can result in severe injury. All

## SAFETY RULES

slopes require extra caution. If you feel uneasy on a slope, do not trim it.

**Do** trim across the face of slopes; never up and down. Do not trim excessively steep slopes (maximum 15 degrees) or areas where the ground is very rough. See the "Guide" in the back of this manual to check a slope. Exercise extreme caution when changing direction on slopes.

**Do** remove objects such as rocks, tree limbs, etc

**Do** watch for holes, ruts, or bumps. Tall grass can hide obstacles.

**Do not** trim near drop-offs, ditches, or embankments. The operator could lose footing or balance.

**Do not** trim excessively steep slopes.

**Do not** trim on wet grass. Reduced footing could cause slipping.

### III. Children

Tragic accidents can occur if the operator is not alert to the presence of children. Children are often attracted to the trimmer and the trimming activity. *Never* assume that children will remain where you last saw them.

1. Keep children out of the trimming area and under the watchful care of a responsible adult.
2. Be alert and turn trimmer off if children enter the area.
3. Before and while moving backwards, look behind and down for small children.
4. Never allow children to operate the trimmer.
5. Use extra care when approaching blind corners, shrubs, trees, or other objects that may obscure vision.
6. On electric start models, remove the ignition key to prevent accidental starting when the trimmer is not in use.

### IV. Service

1. Use extra care in handling gasoline and other fuels. They are flammable and vapors are explosive.
  - a. Use only an approved container.
  - b. Never remove gas cap or add fuel with the engine running. Allow engine to cool before refueling. Do not smoke.

c. Never refuel the machine indoors.

d. Never store the machine or fuel container inside where there is an open flame, such as a water heater.

2. Never run an engine indoors or inside a closed area.
3. Never make adjustments or repairs with the engine (motor) running. Disconnect the spark plug wire, and keep the wire away from the plug to prevent accidental starting (remove the ignition key if equipped with an electric start). Always wear eye protection when you make adjustments or repairs.
4. Check the trimmer head and engine mounting bolts at frequent intervals for proper tightness.
5. Keep all nuts and bolts tight and keep equipment in good condition. Check mounting hardware on trimmer head every time you change trimmer line and prior to each use.
6. Never tamper with safety devices. Check their proper operation regularly.
7. When servicing or repairing the trimmer, do not tip the machine over or up unless specifically instructed to do so in this Manual. Service and repair procedures can be done with the trimmer in an upright position. Some procedures will be easier if the machine is lifted on a raised platform or working surface.
8. To reduce fire hazard, keep trimmer free of grass, leaves, or other debris build-up. Clean up oil or fuel spillage. Allow trimmer to cool before storing.
9. Stop and inspect the equipment if you strike an object. Repair, if necessary, before restarting.
10. Always disconnect spark plug wire before cleaning, repairing, or adjusting.
11. Do not change the engine governor setting or over-speed the engine.
12. Clean and replace safety and instruction decals as necessary.
13. To guard against engine over-heating, always have engine debris filter mounted and clean.
14. Inspect trimmer before storage.
15. Use only original equipment or authorized replacement parts.

# SAFETY RULES

## INTERNATIONAL SYMBOLS

**IMPORTANT:** Many of the following symbols are located on your unit or on literature supplied with the product. Before you operate the unit, learn and understand the purpose for each symbol.

### Control And Operating Symbols



Slow



Fast



Fuel



Oil

### Safety Warning Symbols



**WARNING**  
Thrown Objects.  
Keep Bystanders Away.



**WARNING**  
Rotating Parts. Stop Engine.  
Disconnect Spark Wire Before  
Making Adjustments.



**WARNING**



**IMPORTANT**  
Read Owner's Manual  
Before Operating  
This Machine.



**WARNING**  
Wear Eye Protection



**STOP**



**WARNING**  
Never Operate Up Or  
Down Slopes. Operate  
Across Slopes.

# ASSEMBLY

## ASSEMBLY

### CONTENTS OF PARTS BAG

- 1 - Owner's Manual
- 1 - Parts Bag

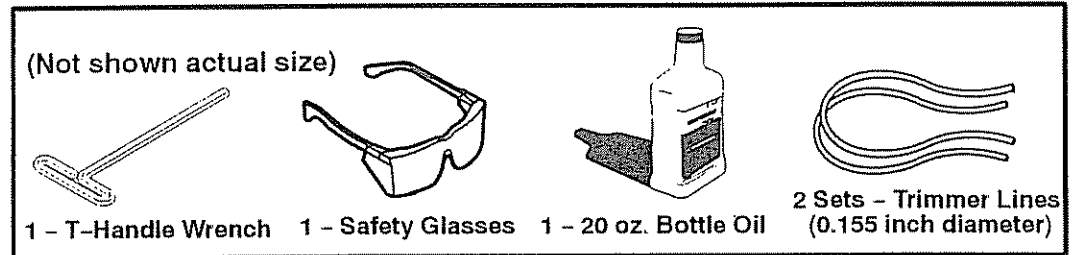

**WARNING:** Always wear safety glasses or eye shields while assembling the trimmer.

### TOOLS REQUIRED

- 1 - Knife to cut carton.
- 1 - T-Handle Wrench

Figure 1 shows the trimmer completely assembled and positioned in the carton for shipment

References to the right or left hand side of the trimmer are from the viewpoint of the operator's position behind the unit

### TO REMOVE THE TRIMMER FROM CARTON

- 1 Remove the bottle of oil and parts bag from carton
- 2 Remove the packing material positioned around the unit
- 3 Cut down all four corners of the carton and lay the side panels flat
- 4 Pull the trimmer out of the carton and off the base pad
- 5 Remove packing material from around the trimmer head
- 6 Remove protective plastic from front of frame

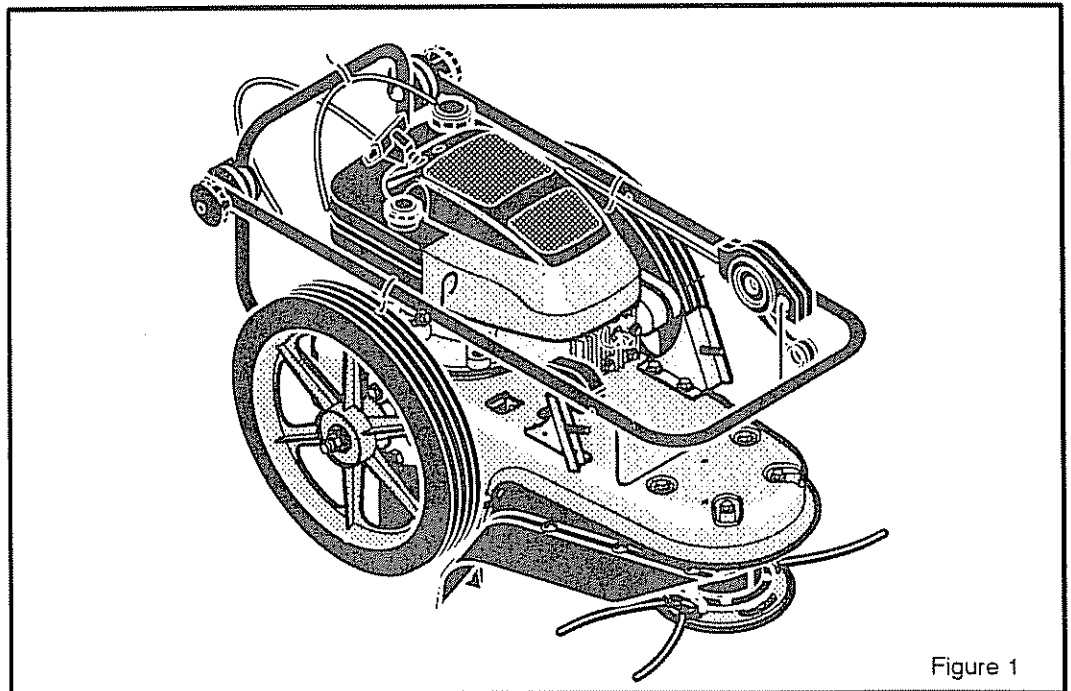

Figure 1

## ASSEMBLY

### HOW TO RAISE THE HANDLE

1 Hold the **handle** with one hand and loosen both **handle adjustment knobs** until the ratchet teeth are disengaged. Do not remove the **handle adjustment knobs**. See Figure 2.

2 Raise the **handle** to the operating position.

3 Stand in the operator's position behind the trimmer. Put the **handle** in a comfortable position. Make sure both sides of the **handle** are level.

**NOTE: Make sure the cables are not caught between the upper and lower handle.**

4 Tighten the **handle adjustment knobs**. Make sure the **handle pivots** are locked in place.

**NOTE: The handle height is adjustable. See "How To Adjust The Height Of The Handle" in the Adjustment section.**

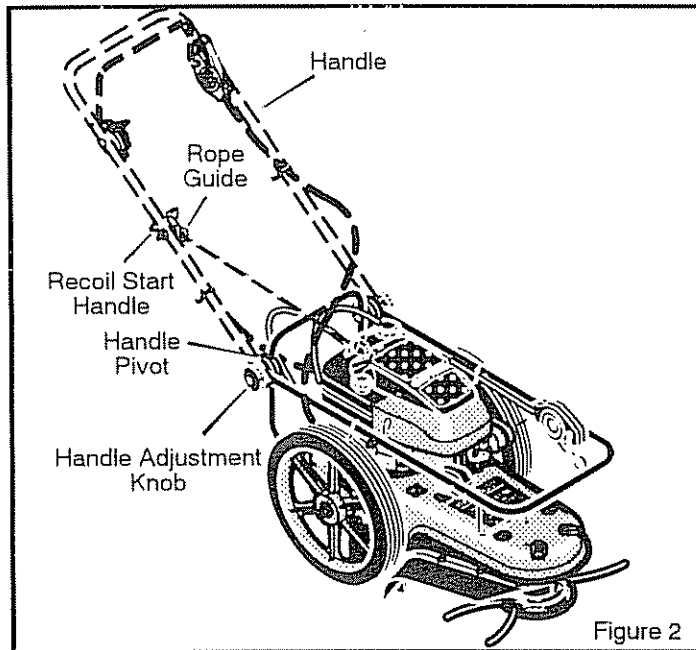

Figure 2

5 To attach the **recoil start handle** to the **rope guide**, twist the rope through the **rope guide** mounted on the right side of the handle.

### HOW TO INSTALL THE ENGINE DEBRIS SHIELD

1 Remove the engine debris shield from the protective packaging.

2 Attach the engine debris shield to the two mounting brackets with the wingnuts as shown in Figure 3. Make sure the wingnuts are tight.

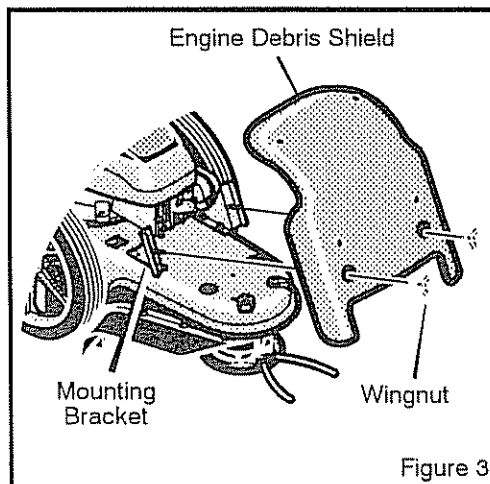

Figure 3

# ASSEMBLY

## ENGINE PREPARATION

### Fill Crankcase With Oil

The trimmer was shipped with a container of SAE30 motor oil. This oil must be added to the engine before operating.

- 1 Remove the oil fill cap/dipstick shown in Figure 4. Fill the crankcase to the **FULL** line on oil fill cap/dipstick. **DO NOT OVER-FILL.**
- 2 Install the oil fill cap/dipstick and tighten securely.

### Fill Fuel Tank With Gasoline

For the correct procedure and grade of gasoline, see "How To Fill With Gasoline" in the Operation section.

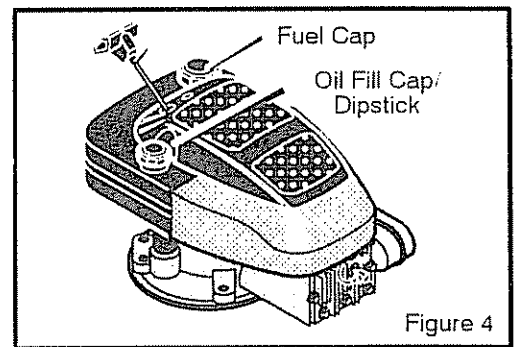

Figure 4

---

## ✓ CHECKLIST

For the best performance and satisfaction from this quality product, please review the following checklist before you operate the trimmer:

- ✓ All assembly instructions have been completed
- ✓ Check carton. Make sure no loose parts remain in the carton.

As you learn how to use the trimmer, pay extra attention to the following important items:

- ✓✓ Engine oil is at correct level
- ✓✓ Fuel tank is filled with fresh, clean, regular unleaded gasoline.
- ✓✓ Become familiar and understand the function of all controls. Before you start the engine, operate all controls.



# OPERATION

## KNOW YOUR TRIMMER

READ THE OWNER'S MANUAL AND ALL SAFETY RULES BEFORE YOU OPERATE the trimmer. To familiarize yourself with the location of the controls, compare the illustrations with your trimmer. Save this manual for future reference.

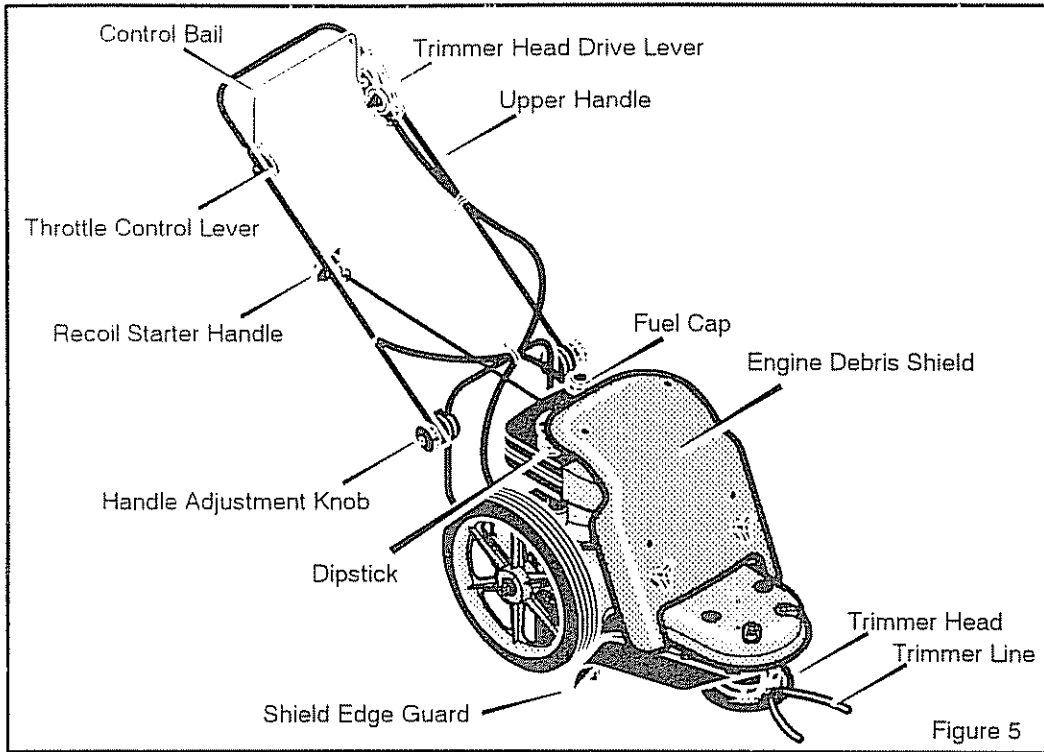

Figure 5

**Trimmer Head Drive Lever** – Engages the rotation of the trimmer head

**Control Bail** – Release to stop the rotation of the trimmer head

**Throttle Control Lever** – Controls the speed or stops the engine

**Primer Button** – Injects fuel directly into the carburetor manifold for faster starts. See Figure 8

**Recoil Starter Handle** – The engine is equipped with an easy pull recoil starter.

**Shield Edge Guard** – Protects the shield by automatically cutting the line to the correct length.

**Engine Debris Shield** – Protects the engine from debris. Can be easily removed to service the engine.

## EYE PROTECTION

**WARNING:** Debris thrown from the trimmer can result in foreign objects being thrown into the eyes, which can cause severe eye damage. Always wear safety glasses or eye shields when operating the trimmer.



Always wear safety glasses. If you wear eye glasses, put a Wide Vision Safety Mask over your eye glasses.

## HOW TO STOP THE TRIMMER HEAD

- 1 Release the **control bail**. It will return to its open position and disengage the trimmer head.

## HOW TO STOP THE ENGINE

- 1 Move the **throttle control lever** completely back to the STOP position.

## OPERATION

### HOW TO USE THE TRIMMER HEAD DRIVE LEVER

- 1 To engage the trimmer head, hold the **control bail** against the **handle**. Move the **trimmer head drive lever** forward to engage the trimmer head. See Figure 6. The faster the engine runs, the faster the trimmer head will rotate.
- 2 Once the trimmer head is rotating, push the trimmer forward to trim.

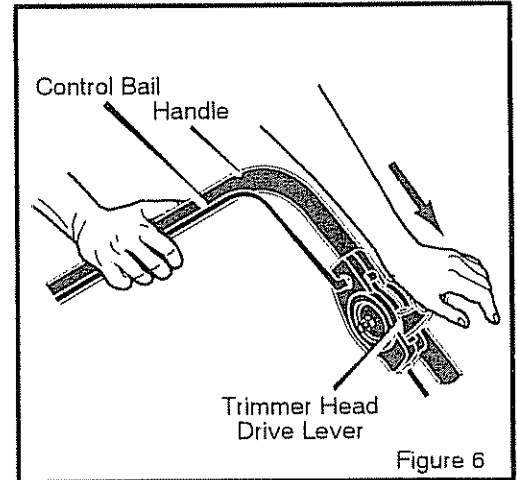

### HOW TO USE THE THROTTLE CONTROL

- 1 During normal use, set the **throttle control lever** in the FAST position to run the engine at full speed.
- 2 Pull the **throttle control lever** back to decrease engine speed. Push the **throttle control lever** forward to increase engine speed.
- 3 To stop the engine, pull the **throttle control lever** completely back to the STOP position.

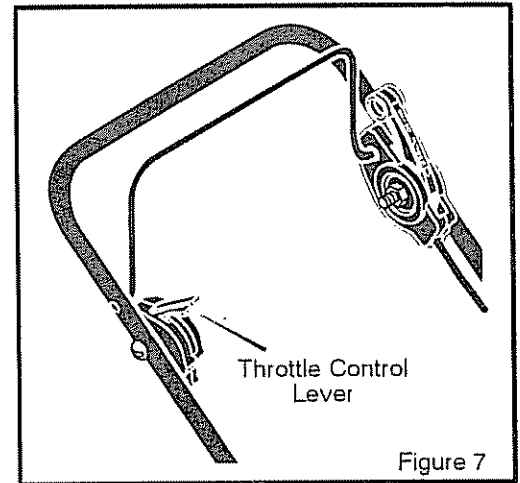

### HOW TO USE THE PRIMER BUTTON

- 1 Push the **primer button** five times. See Figure 8 for location. Wait approximately two seconds between each push.

**NOTE:** Do not use the primer button to restart a warm engine after a short shutdown.

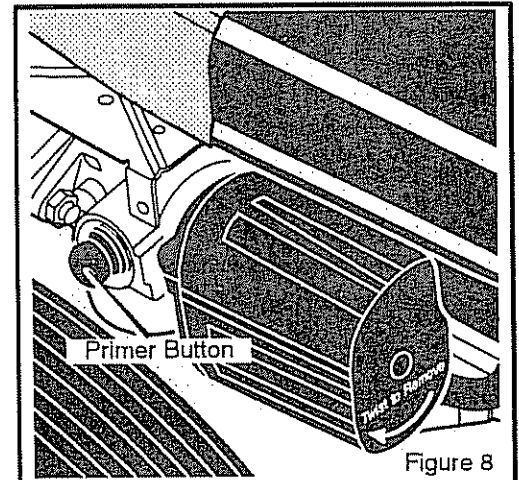

# OPERATION

## BEFORE STARTING THE ENGINE

### Oil Recommendation

Only use high quality detergent oil rated with API service classification SG. Select the oil's SAE viscosity grade according to your expected operating temperature:

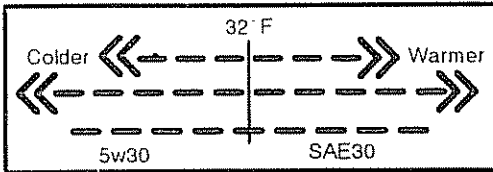

**NOTE:** Although multi-viscosity oils (5W30, 10W30, etc.) improve starting in cold weather, these multi-viscosity oils will result in increased oil consumption when used above 32°F. To avoid possible engine damage from running low on oil, frequently check your engine oil level.

### Check The Engine Oil

Before each use, check the engine oil as follows:

- 1 Put the trimmer on a level surface
- 2 Remove the oil fill cap/dipstick shown in Figure 9
- 3 Make sure the oil reaches the FULL mark on the oil fill cap/dipstick
- 4 If necessary, add oil until the FULL mark on the oil fill cap/dipstick is reached. **DO NOT OVERFILL.** See "Oil Recommendation" for the grade and type of oil to use

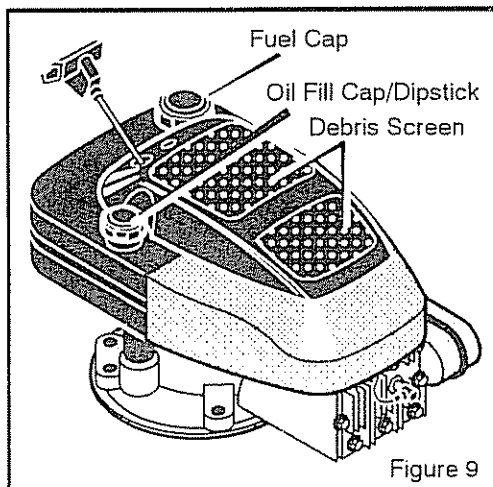

Figure 9

### How To Fill With Gasoline

**NOTICE:** ENGINES WHICH ARE CERTIFIED TO COMPLY WITH CALIFORNIA AND US EPA EMISSION REGULATIONS FOR ULGE ENGINES: Are certified to operate on regular unleaded gasoline. Include the following emission control system(s): EM, TWC (if so equipped). Include any user adjustable features—therefore no other adjustments are needed.



**WARNING:** Never fill the gas tank while the engine is running or hot. Allow the engine to cool before adding gasoline. Immediately wipe off any spilled gasoline before you start the engine.



**WARNING:** Gasoline is flammable. Use caution when handling or storing gasoline. Keep away from an open flame or an electrical spark. Do not smoke while filling the fuel tank. Store gasoline in a clean, approved container in a cool well ventilated place; never in the house.

Fill the fuel tank with a fresh, clean, unleaded regular, unleaded premium, or reformulated automotive gasoline only. **DO NOT** use leaded gasoline. Be sure that the gasoline container is clean and free from dust or other foreign particles. Never use gasoline that is stale from long periods of storage. Reinstall fuel cap.

**CAUTION:** Alcohol blended fuels (called gasohol or using methanol) can attract moisture which leads to separation and formation of acids during storage. Acidic gas can damage the fuel system of an engine while in storage. To avoid engine problems, empty the fuel system before storage of 30 days or longer. Drain the fuel tank. Start the engine and let it run until the fuel lines and carburetor are empty. Never use engine or carburetor cleaner products in the fuel tank or permanent damage may occur. See "Storage Instructions" for additional information.

## OPERATION

### HOW TO START THE ENGINE

**NOTE:** DO NOT BE ALARMED, your engine will smoke the first time it is started. It is burning off the protective coating that is on the internal engine parts.



**WARNING:** Never leave the trimmer unattended while the engine is running. Wait for the trimmer lines to stop rotation.

1 Before each use, remove debris from the **debris screen** shown in Figure 9. Debris can cause the engine to overheat. Wipe the **debris screen** with a cloth or paper towel.

2 Move the throttle control lever forward to the START or FAST position.

3 To start a cold engine, push the primer button five times. Wait two seconds between each push of the primer button.

**NOTE:** Do not use the primer to start a warm engine.

4 Firmly hold the **recoil starter handle** with your right hand. See Figure 10.

5 Pull back sharply on the **recoil starter handle**. DO NOT allow the starter rope to snap back. Let the starter rope slowly rewind as you hold the recoil starter handle.

**NOTE:** If engine fails to start after three pulls, push the primer button two times and again pull the recoil starter handle.



**WARNING:** Never run the engine indoors or in a poorly ventilated area. Engine exhaust contains carbon monoxide, an odorless and deadly gas. Keep hands, feet, hair and loose clothing away from the trimmer and any moving parts on the engine. Avoid the muffler and surrounding areas. Temperatures may exceed 150°F.

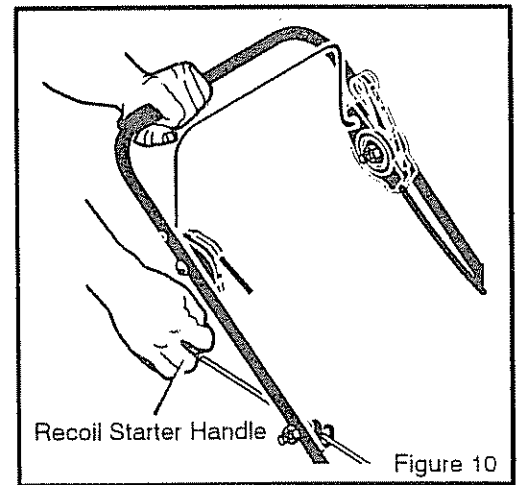

### TRIMMER TIPS



**WARNING:** Debris such as sticks, gravel or rocks, can be thrown with sufficient force to cause personal injury or property damage.

- Set the throttle control in the FAST position. If the weeds or grass are tall and thick, operate the trimmer at a slower walking speed.
- Frequently clean the underside of the trimmer to remove any grass build up. See the Maintenance section for details.
- For best results and longer lasting line, use the ends of the line to do the cutting. This is easily done by moving slowly through very thick or heavy weeds.
- If the trimmer lines become too short, it will

take longer to complete the job. If the trimmer lines are worn to less than half their original length, change to a new trimmer line. "See How To Change The Trimmer Line" in the Service And Adjustment section.

- Do not trim on excessively steep slopes. If a slope is difficult to stand on, do not trim. Do not trim on slopes when the ground is slippery or wet. Trim across the face of a slope, not up and down.
- Trimmer head contact to concrete, asphalt and harder surfaces may create premature wear to the **height guide** (See Figure 18).

# MAINTENANCE

## CUSTOMER RESPONSIBILITIES

SERVICE RECORDS  Fill in dates as you complete regular service.	Before Each Use	Every 5 Hours	Every 25 Hours	Every 100 Hours	As Noted	SERVICE DATES
Check Engine Oil Level	√					
Check trimmer Lines	√				1	
Check Trimmer Head Engagement	√					
Engine/Machine Cleaning	√				2	
Check Nuts and Bolts	√					
Check Spark Plug			√			
Change Engine Oil			√			
Service Air Filter			√		3	
Lubricate Jackshaft Assembly			√			
Lubricate Wheel Bearings			√			

**Note 1** - When old line is half the original length, replace with new line

**Note 2** - Clean daily if used in extremely dusty or dirty conditions.

**Note 3** - Change more often if used in extremely dusty or dirty conditions.

### PRODUCT SPECIFICATIONS

Trimmer Line Diameter	0.155 inch
Trimmer Line Length	21.5 inches
Horse Power	6.5
Displacement	12.0 cu. in.
Gasoline Capacity	1.5 quarts
Oil Capacity	20 oz.
Spark Plug	Champion RJ-19LM
Spark Plug Gap	0.030 inch

### GENERAL RECOMMENDATIONS

The warranty on this trimmer does not cover items that have been subjected to operator abuse or negligence. To receive full value from the warranty, the operator must maintain the trimmer as instructed in this manual.

Some adjustments must be made periodically to properly maintain your trimmer.

All adjustments in the Service and Adjustments section of this manual must be checked at least once each season.

# MAINTENANCE

## LUBRICATION

### How To Lubricate The Jackshaft Assembly

A **grease fitting** is provided to lubricate the jackshaft assembly. Use a grease gun with automotive type grease to lubricate the jackshaft assembly as shown in Figure 11.

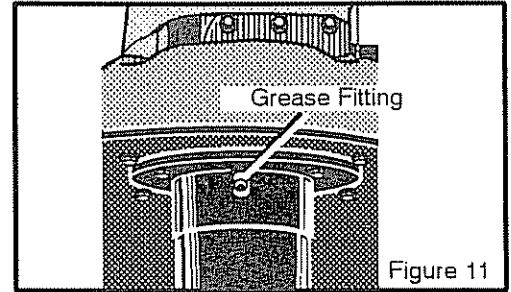

### How To Change Engine Oil

Change the engine oil when the engine is warm. For the proper oil capacity, see "Product Specifications".

- 1 Disconnect spark plug wire from the spark plug.
- 2 Remove the **oil drain plug** as shown in Figure 12.
- 3 Drain all the engine oil into a flat pan.
- 4 Install the **oil drain plug**. Make sure the **oil drain plug** is tight.
- 5 Remove the dipstick.
- 6 Fill the engine crankcase. **DO NOT OVERFILL**. For proper oil capacity, see "Product Specifications".

- 7 Connect the spark plug wire to the spark plug.

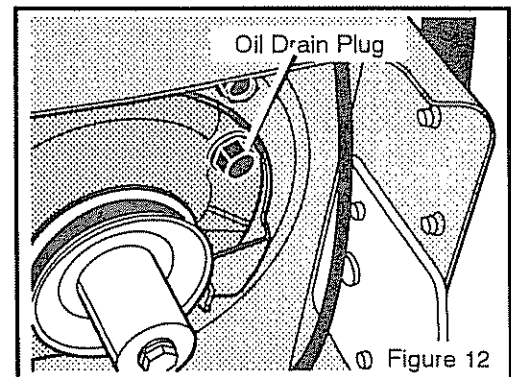

## HOW TO REPLACE THE AIR FILTER

Replace the air filter once a year or more often in dusty or dirty conditions. **DO NOT** attempt to clean or oil the air filter. Remove and install a new air filter as follows:

**CAUTION: Never run the engine without the air filter installed. An air filter clogged with dust can result in loss of engine power and can cause excessive wear or damage to the engine. If the air filter is clogged, replace immediately.**

- 1 Disconnect the spark plug wire from the spark plug.
- 2 Turn the **cover** clockwise as shown in Figure 13. Remove the **cover** and the **air filter**.
- 3 Discard the old **air filter**.
- 4 Clean the **cover** and the **flange**.

- 5 Put the new **air filter** into the **cover**.
- 6 Push the **cover** firmly against the **flange**. Turn the **cover** counterclockwise until tight. Be sure the retainers are locked around the **flange**.
- 7 Connect the spark plug wire to the spark plug.

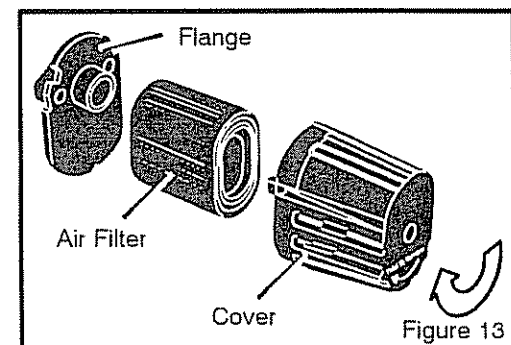

## MAINTENANCE

### HOW TO SERVICE THE ENGINE AND SPARK PLUG

- 1 To access the engine or the spark plug, remove the engine debris shield as shown in Figure 14
- 2 After engine service is completed, replace the engine debris shield

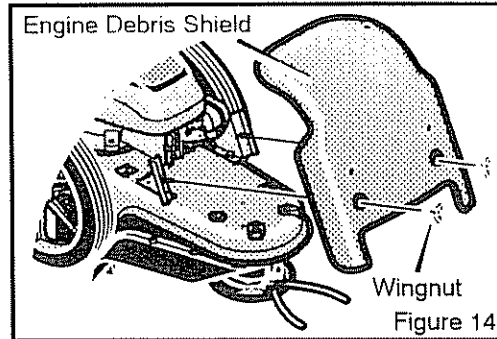

---

### SPARK PLUG

Check the **spark plug** every 25 hours. Replace the **spark plug** if the electrodes are pitted or burned or if the porcelain is cracked.

- 1 Make sure the **spark plug** is clean. Clean the **spark plug** by carefully scraping the electrodes (do not sand blast or use a wire brush).
- 2 Check the **spark plug** gap with a **feeler gauge**. See "Product Specifications" for the correct **spark plug** gap and replacement **spark plug**.
- 3 Before installing the **spark plug**, coat the threads lightly with oil for easy removal.

Tighten the spark plug to a torque of 15 foot-pounds.

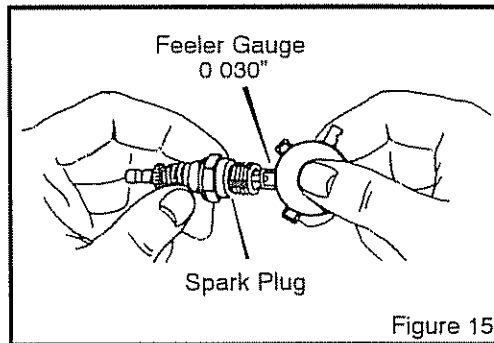

# SERVICE AND ADJUSTMENT

## SERVICE AND ADJUSTMENT



**WARNING:** Before you inspect, clean or service the trimmer, stop the engine. Make sure that all moving parts have stopped. Disconnect the wire from the spark plug.

### HOW TO REPLACE THE TRIMMER LINE

For the best performance, use a heavy gauge (0.155" diameter) trimmer line. Cut the length of the trimmer line to 21.5 inches. Use the length guide, located on the shield, to make sure the trimmer line is the correct length. See Figure 16. Do not allow the length of the lines to vary more than one inch. This is important to make sure the trimmer head is balanced and does not vibrate.

**IMPORTANT:** To extend the life of the trimmer line, keep the trimmer line moist. If not kept moist, the nylon trimmer line will become dry and brittle. Keep extra trimmer line in a can of water. The line will then stay flexible and easy to change. A flexible line will also last much longer.

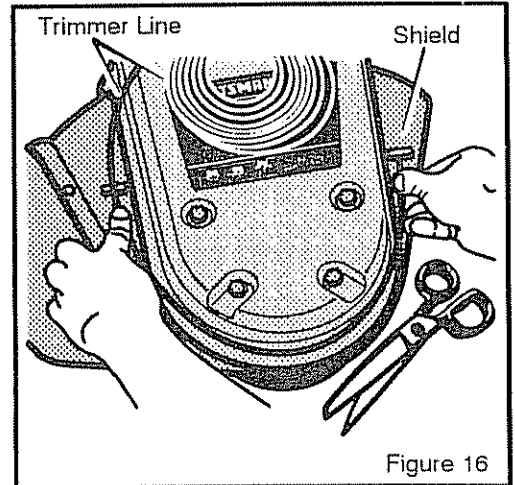

### HOW TO CHANGE TRIMMER LINES

When the trimmer line becomes worn to half the original length, replace the trimmer line as follows:

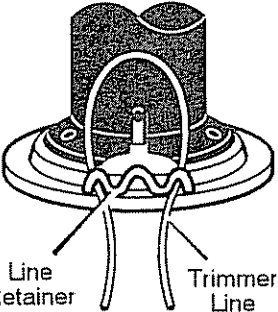
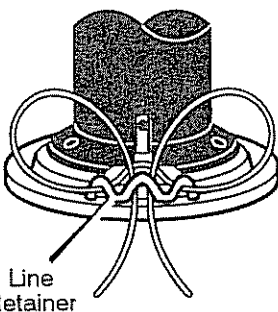
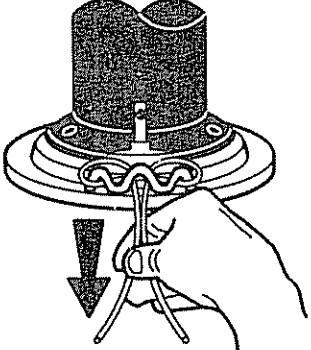
 <p>Line Retainer Trimmer Line</p>	 <p>Line Retainer</p>	
<p>1 Stop the engine. Wait for all moving parts to stop.</p> <p>2 Remove worn trimmer line from line retainer.</p> <p>3 <i>First</i>, thread the ends of the new trimmer line through the outside loops.</p>	<p>4 <i>Next</i>, take the ends of the line, cross over the line retainer, and thread the ends through the center hole.</p>	<p>5 <i>Then</i>, check to make sure that the ends of the line are even.</p>



## SERVICE AND ADJUSTMENT

### HOW TO ADJUST THE HEIGHT OF THE HANDLE

Use the **knobs** on each side of the **handle** to adjust the height of the handle

- 1 Hold the **handle** with one hand and loosen both **knobs** until the **ratchet teeth** are disengaged. Do not remove the **knobs**. See Figure 17
- 2 Move the **handle** up or down to the desired position, then align the **ratchet teeth**. Make sure both sides of the **handle** are level
- 3 Tighten the **knobs**

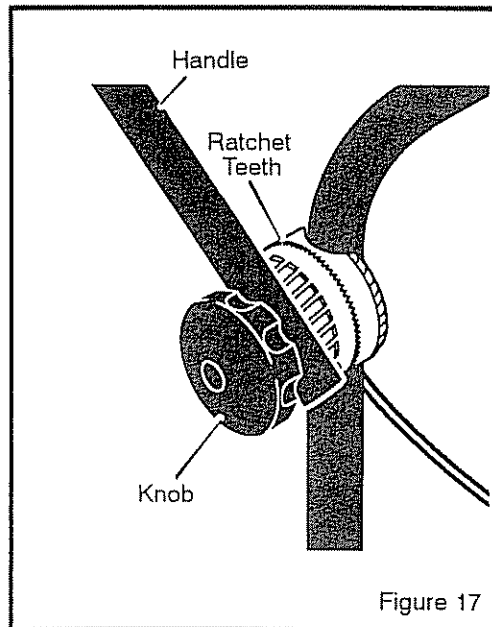

### HOW TO SET THE HEIGHT OF CUT



**CAUTION:** Before you set the height of cut, stop the engine. Wait for all moving parts to stop. Allow the engine to cool and disconnect the spark plug wire.

The height of cut can be set from 1-1/2 inches to 3 inches. Recommended cutting height for the average yard is 2"

- 1 Use the **T-wrench**, found in the parts bag, to loosen the **set screw** shown in Figure 18
- 2 Set the **trimmer head** at the desired height
- 3 Tighten the **set screw**.

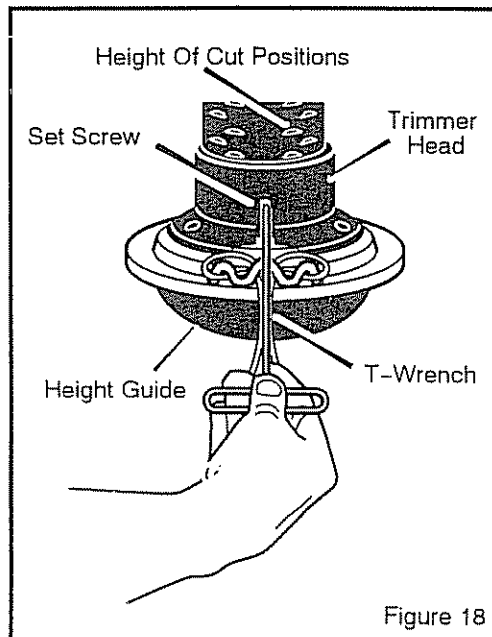

# SERVICE AND ADJUSTMENT

## HOW TO REPLACE THE DRIVE BELT

To replace the drive belt, the trimmer head and shield must be removed as follows



**WARNING:** Before you remove the drive belt, disconnect the wire from the spark plug.

1. Remove the two fasteners that hold the rear of the **shield** to the **trimmer housing** (See Figure 19).
2. Remove the four fasteners that hold the front of the **shield** and **trimmer head** to the **trimmer housing**.
3. Remove the "V" pulley from the idler bracket.
4. Raise the front of the **trimmer housing** and remove the **drive belt**. On some models, it is necessary to loosen the **mounting bolt** for the **drive pulley** to remove the drive belt (see Figure 20). Do not bend the belt guides

**NOTE:** Make sure you replace the drive belt only with a replacement belt from the factory.

5. To assemble the **drive belt**, reverse the above steps. Make sure all fasteners are tight. Make sure the **mounting bolt** for the **drive pulley** is tight.
6. Check the routing of the **drive belt**. Make sure the **drive belt** is inside of all **belt guides** shown in Figure 20.

**IMPORTANT:** Test the drive system. Start the engine and move the throttle control to the FAST position. Engage and disengage the trimmer head several times. When disengaged, make sure the trimmer head completely stops when resting on the ground. If the trimmer head continues to rotate, take the trimmer to the nearest Craftsman Service Center.

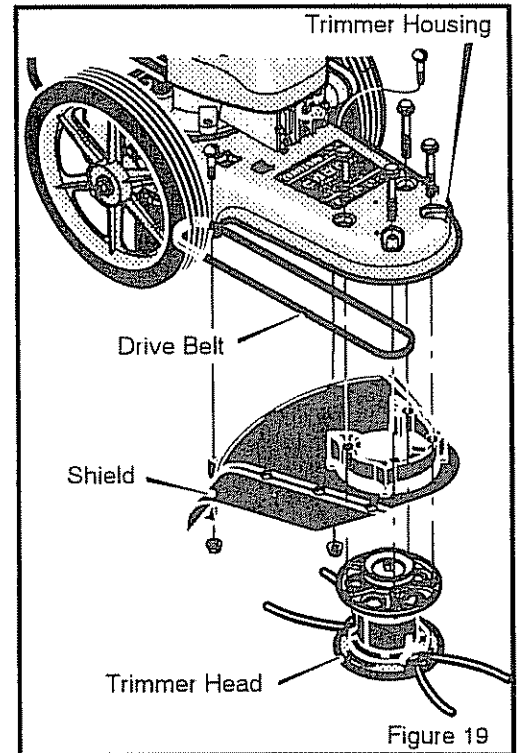

Figure 19

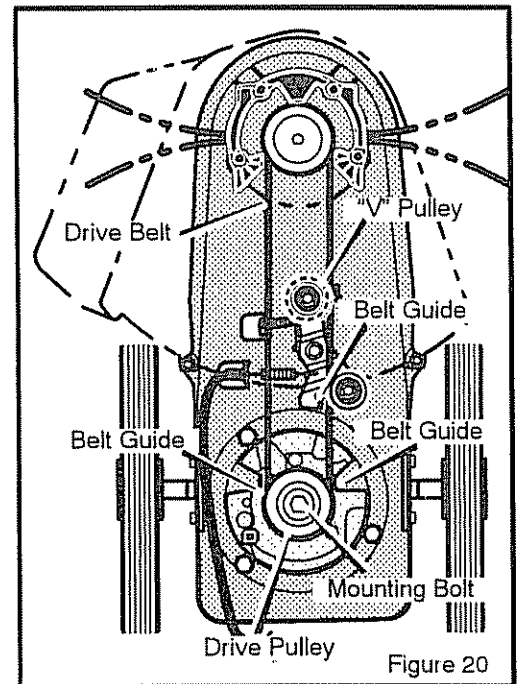

Figure 20

# SERVICE AND ADJUSTMENT

## STORAGE



**WARNING:** Do not remove gasoline while inside a building, near a fire, or while you smoke. Gasoline fumes can cause an explosion or a fire.

When the trimmer is put in storage for thirty days or more, follow the steps below to make sure the trimmer is in good condition the following season.

### Trimmer

- Completely clean the trimmer
- Put the trimmer in a building that has good ventilation

**NOTE:** A yearly checkup or tune-up at a Craftsman authorized service center will make sure that the trimmer will provide maximum performance for the next season.

### Engine

**IMPORTANT:** It is important to prevent gum deposits from forming in fuel system parts such as the carburetor, fuel filter, fuel hose, and tank during storage. Also, using alcohol-blended fuels (called gasohol, ethanol or methanol) can attract moisture which leads to separation and formation of acids

during storage. Acidic gas can damage the fuel system of an engine while in storage.

To prevent engine damage when the trimmer is in storage for 30 days or more, follow the steps below:

- Let the engine run until it is out of gasoline.
- Drain the oil from the warm engine. Fill the engine crankcase with new oil.
- Remove the spark plug from the cylinder. Pour one ounce of oil into the cylinder. Slowly pull the recoil starter handle so that the oil will protect the cylinder. Install a new spark plug in the cylinder.
- Clean dirt and debris from the cylinder cooling fins and the engine housing.
- If you do not want to remove gasoline, add a fuel stabilizer, such as Craftsman fuel stabilizer No. 33500, to any gasoline left in the tank. Craftsman fuel stabilizer will minimize the formation of gum deposits and acids. If the tank is almost empty, mix Craftsman fuel stabilizer with fresh gasoline in a separate container and add the mixture to the tank. Always follow the instructions on the stabilizer container. Run the engine at least ten minutes after stabilizer is added to allow the mixture to reach the carburetor.

## TROUBLE SHOOTING CHART

TROUBLE	CAUSE	CORRECTION
<b>Engine does not start</b>	Spark plug wire disconnected	Connect spark plug wire
	Engine not primed	Prime engine.
	Defective or incorrectly gapped spark plug	Inspect or replace spark plug.
	Fuel tank empty.	Add fuel
	Dirty carburetor or fuel line	Clean carburetor or fuel line
	Dirty air filter.	Replace air filter
	Carburetor out of adjustment	For carburetor adjustment, take the unit to a Craftsman Service Center
	Engine flooded	Wait several minutes before starting
	Throttle control lever in incorrect position.	Move throttle lever to FAST or START position
	Stale gasoline	Drain old gasoline and add fresh gasoline.
	Defective throttle control lever or wire	Inspect lever and wire. Replace if damaged or defective.
<b>Engine runs poorly.</b>	Bad spark plug	Replace spark plug.
	Dirty air filter	Replace air filter.
	Carburetor out of adjustment.	Adjust carburetor. Take the unit to a Craftsman Service Center.
	Stale gasoline.	Drain old gasoline. Add fresh gasoline
	Engine cooling system clogged	Clean engine screen and cooling fins.

## TROUBLE SHOOTING CHART

Engine overheats.	Engine cooling system clogged	Clean debris screen and engine cooling fins
	Carburetor out of adjustment	Adjust carburetor. Take the unit to a Craftsman Service Center
	Oil level is low	Add oil.
Engine will not stop running.	Defective throttle control lever or wire	Inspect and replace damaged parts.
	Throttle not adjusted properly	Move throttle to the full OFF position.
Poor trimming performance.	Trimmer line length is too short	Correct line length is 21 5 inches. When less than 1/2 this length, replace the line
	Engine not set at FAST speed	Move engine throttle lever to FAST position
Trimmer vibrates.	Set screw for trimmer head is loose.	Tighten set screw with T-handle wrench
	Trimmer line lengths are substantially different.	Adjust trimmer line to approximately equal lengths
	Loose nuts or bolts	Check all bolts and nuts, including engine bolts.
	Broken trimmer head.	Replace broken part
Trimmer head does not retain line	Trimmer line not properly attached.	Follow instructions on decal or in the Service section of the owner's manual.
	Broken line retainer	Replace trimmer head assembly
	Trimmer line not correct size	Use Craftsman 0.155 inch diameter trimmer line

712490

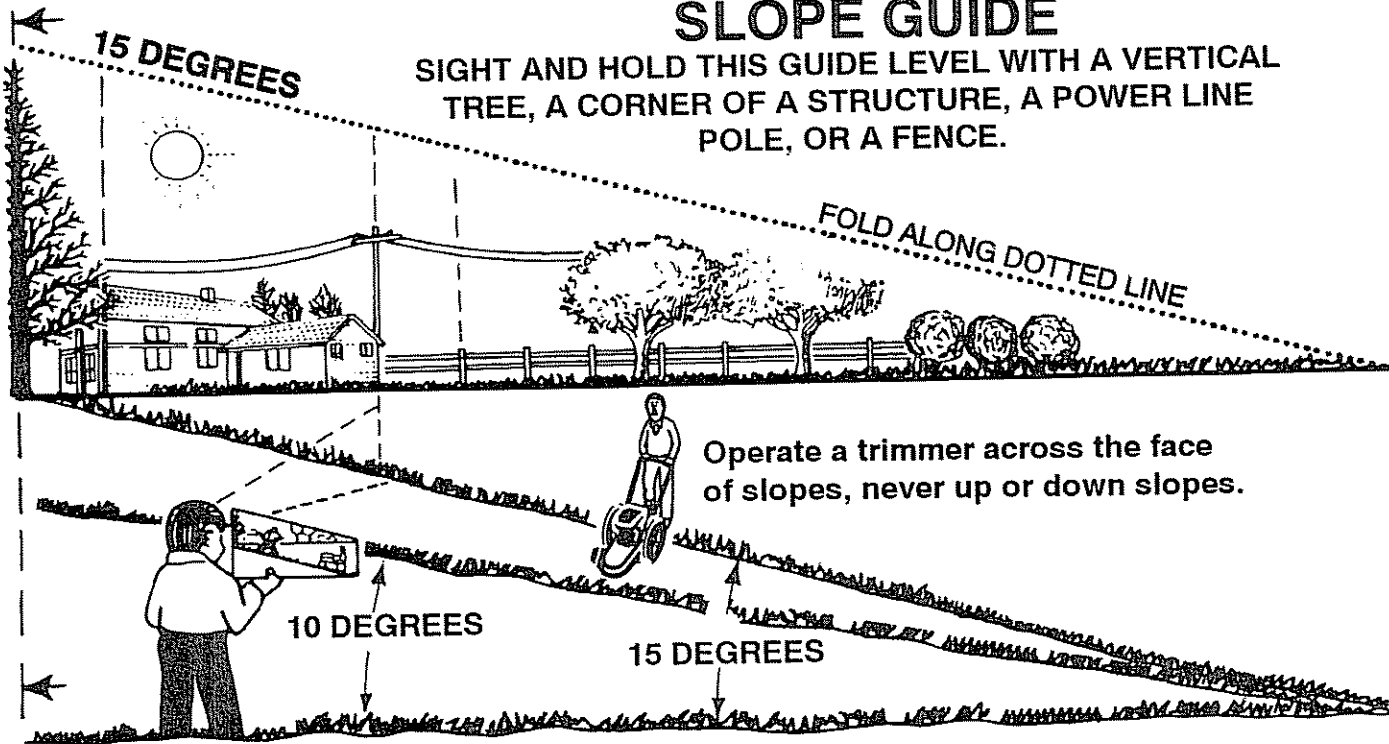

## SLOPE GUIDE

SIGHT AND HOLD THIS GUIDE LEVEL WITH A VERTICAL TREE, A CORNER OF A STRUCTURE, A POWER LINE POLE, OR A FENCE.

Use this guide and do not trim on a slope greater than 15 degrees.

A 10 degree slope is a hill that increases in height at approximately 1.7 feet in 10 feet..

A 15 degree slope is a hill that increases in height at approximately 2.5 feet in 10 feet..



Use extreme care at all times and avoid sudden turns or maneuvers. Follow other instructions in this manual for safety in trimming on slopes. Operate a trimmer across the face of slopes, never up or down slopes. Use extra care when operating on or near slopes and obstructions.