



Dear VIZIO Customer,

Congratulations on your new VIZIO SV470XVT1A LCD Television purchase. Thank you for your support. For maximum benefit of your set, please read these instructions before making any adjustments, and retain them for future reference. We hope you will experience many years of enjoyment from your new VIZIO SV470XVT1A Television.

For assistance, please call (877) 698-4946 or e-mail us at techsupport@vizio.com.

To purchase or inquire about accessories and installation services for your VIZIO LCD HDTV, please visit our website at www.vizio.com or call toll free at **888-VIZIOCE (888-849-4623)**.

We recommend you register your VIZIO SV470XVT1A TV either at our website www.vizio.com or fill in your registration card and mail it in. For peace of mind and to protect your investment beyond the standard warranty, VIZIO offers on-site extended warranty service plans. These plans give additional coverage during the standard warranty period. Visit our website or call us to purchase a plan.

Write down the serial number located on the back of your SV470XVT1A. _____

Purchase Date _____

*VIZIO is a registered trademark of VIZIO, Inc. dba V, Inc.
HDMI logo and "High Definition Multimedia Interface" are registered trademarks of HDMI Licensing LLC.
Manufactured under license from Dolby Laboratories.
Dolby and the double-D symbol are trademarks of Dolby Laboratories.
TruSurround, SRS and the symbol are trademarks of SRS Labs, Inc*



THE TRADEMARKS SHOWN HEREIN ARE THE PROPERTY OF THEIR RESPECTIVE OWNERS; IMAGES USED ARE FOR ILLUSTRATION PURPOSES ONLY. BRAVO, VIZIO AND THE V LOGO AND WHERE VISION MEETS VALUE AND OTHER VIZIO TRADEMARKS ARE THE INTELLECTUAL PROPERTY OF VIZIO INC. PRODUCT SPECIFICATIONS ARE SUBJECT TO CHANGE WITHOUT NOTICE OR OBLIGATION. © 2008 VIZIO INC. ALL RIGHTS RESERVED.



Important Safety Instructions

This product is designed and manufactured to operate within defined design limits, and misuse may result in electric shock or fire. To prevent the product from being damaged, the following rules should be observed for the installation, use and maintenance of the product. Read the following safety instructions before operating the display. Keep these instructions in a safe place for future reference.

- To reduce the risk of electric shock or component damage, switch off the power before connecting other components to the SV470XVT1A.
- Unplug the power cord before cleaning the SV470XVT1A LCD. A damp cloth is sufficient for cleaning the SV470XVT1A. Do not use a liquid or a spray cleaner for cleaning the product. Do not use abrasive cleaners.
- Always use the accessories recommended by the manufacturer to insure compatibility.
- When moving the SV470XVT1A from an area of low temperature to an area of high temperature, condensation may form on the housing. Do not turn on the SV470XVT1A immediately after this to avoid causing fire, electric shock or component damage.
- Do not place the SV470XVT1A on an unstable cart, stand, or table. If the SV470XVT1A falls, it can injure a person and cause serious damage to the appliance. Use only a cart or stand recommended by the manufacturer or sold with the SV470XVT1A.
- A distance of at least 3 feet should be maintained between the SV470XVT1A and any heat source, i.e. radiator, heater, oven, amplifier etc. Do not install the product close to smoke. Operating the product close to smoke or moisture may cause fire or electric shock.
- Slots and openings in the back and bottom of the cabinet are provided for ventilation. To ensure reliable operation of the SV470XVT1A and to protect it from overheating, be sure these openings are not blocked or covered. Do not place the SV470XVT1A in a bookcase or cabinet unless proper ventilation is provided.
- Never push any object into the slot on the SV470XVT1A cabinet. Do not place any objects on the top of the product. It could short circuit parts causing a fire or electric shock. Never spill liquids on the SV470XVT1A.
- The SV470XVT1A should be operated only from the type of power source indicated on the label. If you are not sure of the type of power supplied to your home, consult your dealer or local power company.
- The power cable must be replaced when using different voltage from that specified in the User Manual. For more information, contact your dealer.
- The SV470XVT1A is equipped with a **three-pronged grounded plug, a plug with a third (grounding) pin**. This plug will fit only into a grounded power outlet as a safety feature. If your outlet does not accommodate the three-wire plug, have an electrician install the correct outlet, or use an adapter to ground the appliance safely. **Do not defeat the safety purpose of the grounded plug.**
- Appliance inlet (or AC inlet) is used as the disconnect device.
- Use only with the cart, stand, tripod, bracket or table specified by manufacturer, or sold with the apparatus. When a cart is used, use caution when moving the cart/apparatus combination to avoid injury from tip-over.



- The lightning flash with arrowhead symbol, within an equilateral triangle, is intended to alert the user to the presence of not isolated dangerous voltage within the inside of the product that may be sufficient magnitude to constitute a risk of electric shock to persons.
- The exclamation point within an equilateral triangle is intended to alert the user to the presence of important operating and servicing instructions in the literature accompanying the appliance.



- Do not overload power strips and extension cords. Overloading can result in fire or electric shock.
- The wall socket shall be installed near the equipment and shall be easily accessible.
- Only the marked power source can be used for the product. Any power source other than the specified one may cause fire or electric shock.
- Do not touch the power cord during lightning. To avoid electric shock, avoid handling the power cord during electrical storms.
- Unplug the unit during a lightning storm or when it will not be used for long period of time. This will protect the SV470XVT1A from damage due to power surges.
- Do not attempt to repair or service the product yourself. Opening or removing the back cover may expose you to high voltages, the risk of electric shock, and other hazards. If repair is required, please contact your dealer and refer all servicing to qualified service personnel.
- Keep the product away from moisture. Do not expose this appliance to rain or moisture. If water penetrates into the product, unplug the power cord and contact your dealer. Continuous use in this case may result in fire or electric shock.
- Do not use the product if any abnormality occurs. If any smoke or odor becomes apparent, unplug the power cord and contact your dealer immediately. Do not try to repair the product yourself.
- Avoid using dropped or damaged appliances. If the product is dropped and the housing is damaged, the internal components may function abnormally. Unplug the power cord immediately and contact your dealer for repair. Continued use of the product may cause fire or electric shock.
- Do not install the product in an area with heavy dust or high humidity. Operating the product in environments with heavy dust or high humidity may cause fire or electric shock.
- Follow instructions for moving the product. Ensure that the power connector and any other cables are unplugged before moving the product.
- Hold the power connector when removing the power cable. Pulling the power cable itself may damage the wires inside the cable and cause fire or electric shock. When the product will not be used for an extended period of time, unplug the power connector.
- To reduce risk of electric shock, do not touch the connector with wet hands.



- Insert batteries in accordance with instructions. Incorrect polarities may cause damage and leakage of the batteries, operator injury and contamination the remote controller.
- If any of the following occurs please contact the dealer:
 - The power connector fails or frays.
 - Liquid sprays or any object drops into the SV470XVT1A.
 - The Display is exposed to rain or other moisture.
 - The Display is dropped or damaged in any way.
 - The performance of the Display changes substantially.
- Operating environment. Temperature: 40°F ~ 95°F, Humidity: 20% ~ 80% non-condensing, Altitude: 0 ~ 6500ft (0 ~ 2000m)

Television Antenna Connection Protection

External Television Antenna Grounding

If an outside antenna/satellite dish or cable system is to be connected to the TV, make sure that the antenna or cable system is electrically grounded to provide some protection against voltage surges and static charges.

Article 810 of the National Electrical Code, ANSI/NFPA 70, provides information with regard to proper grounding of the mast and supporting structure, grounding of the lead-in wire to an antenna discharge unit, size of the grounding conductors, location of antenna discharge unit, connection to grounding electrodes, and requirements of the grounding electrode.

Lightning Protection

For added protection of the TV during a lightning storm or when it is left unattended or unused for long periods of time, unplug the TV from the wall outlet and disconnect the antenna or cable system.

Power Lines

Do not locate the antenna near overhead light or power circuits, or where it could fall into such power lines or circuits.

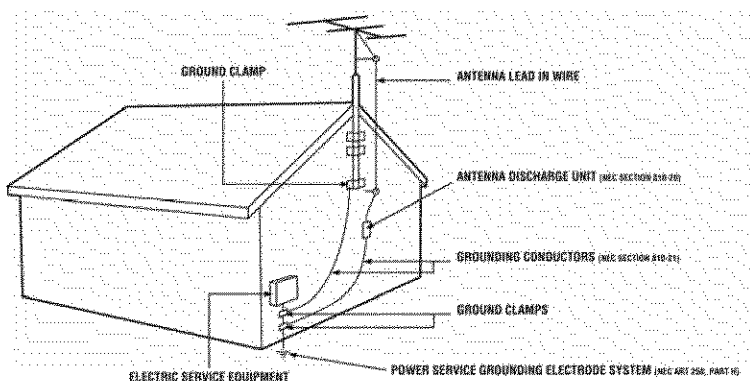

Remember, the screen of the coaxial cable is intended to be connected to earth in the building installation.

FCC Bulletin for New TV Owners

After February 17, 2009, a television receiver with only an analog broadcast tuner will require a converter box to receive full power over-the-air broadcasts with an antenna because of the Nation's transition to digital broadcasting. Analog-only TVs should continue to work as before to receive low power, Class A or translator television stations and with cable and satellite TV services, gaming consoles, VCRs, DVD players, and similar products.

Information about the DTV transition is available from <http://www.DTV.gov> or this manufacturer at 877 MY VIZIO (877-698-4946), and from <http://www.dtv2009.gov> or 1-888-DTV-2009 for information about subsidized coupons for digital-to-analog converter boxes.

Your VIZIO TV comes with a built-in tuner capable of processing digital broadcasts, making it easier for you, the end user, to receive this type of signal without the need of an extra converter box.



Opening the Package

Your VIZIO SV470XVT1A and its accompanying accessories are carefully packed in a cardboard carton that has been designed to protect it from transportation damage. Now you have opened the carton check that the SV470XVT1A is in good condition and that all of the accessories are included.

The SV470XVT1A weighs approximately 78lbs and about 44" wide x 30" tall we strongly advise that you have at least 2 people to unpack and install the HDTV.

The glass surface can easily be scratched or broken so please handle the product gently and never place the HDTV with the glass facing downwards on a surface without protective padding.

IMPORTANT: Save the carton and packing material for future shipping.

Package Contents

VIZIO SV470XVT1A

VIZIO Remote Control VUR9

HDMI Cable

Power Cord

Safety Strap

VIZIO Bezel and Screen Cleaning Cloth

This User Manual

Quick Setup Guide

Registration Card

VIP Services Brochure

2 AAA Batteries for the Remote Control

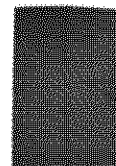
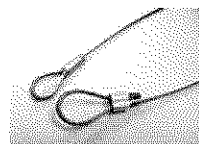
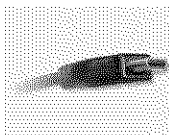
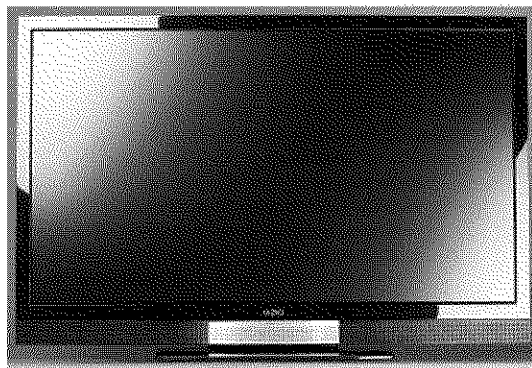

IMPORTANT: Do not apply pressure or throw any object into the screen display area which may compromise the integrity of the display. The manufacturer's warranty does not cover user abuse or improper installations.



Additional Certified Accessories for the VIZIO SV470XVT1A are sold separately

Wall Mounts
High Definition Cables
Extra or replacement Remote

VIZIO also offers Installation Services and Extended Warranty Services for your VIZIO SV470XVT1A

To purchase or inquire about additional accessories and services for your VIZIO product, visit our web site at www.vizio.com or call us toll free at 888-VIZIOCE (888-849-4623)

Installation Preparation

Please read this user manual carefully before installing your VIZIO HDTV.

The power consumption of the TV is about 400W; please use the power cord designated for TV. When an extension cord is required, use one with the correct power rating. The cord must be grounded and the grounding feature must not be defeated.

The TV should be installed on a flat surface to avoid tipping. For proper ventilation, you must allow space between the back of the TV and the wall. If you would like to mount your TV on the wall, please see below 'Preparing Your LCD HDTV for Wall Mounting' for additional information. Avoid installing the TV in places with high humidity, dust or smoke so as not to shorten the service life of the electronic components. Install the TV in landscape orientation; any 90° clockwise or counter-clockwise installation may induce poor ventilation and excessive component damage.

VIZIO offers professional installation services. Please contact VIZIO for more information on these services at 888-VIZIOCE (888-849-4623) or www.vizio.com.

Attaching the Safety Strap

For when the SV470XVT1A is not mounted on the wall with a Wall Mount, a Safety Strap has been included to attach the HDTV to the wall to reduce the chance of the HDTV being pulled over. The Safety Strap should be used with common sense practice such as ensuring that children (or adults) do not climb up, grabbing the top of the HDTV and pulling it onto themselves.

1. Fix one end of the strap to the wall. If you have a drywall finish it is preferable to fix it to a stud, using a washer underneath the screw head. If you have a solid wall you should use a lag bolt, again using a washer under the nut.

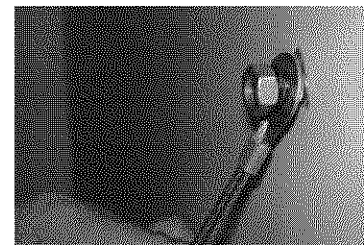

2. Fix the other end of the Safety Strap to one of the upper wall mounting holes on the back of the HDTV, using a washer under the screw head.



Preparing Your LCD HDTV for Wall Mounting

The VIZIO SV470XVT1A can either be kept on the stand base or mounted on the wall for viewing. If you choose to mount the SV470XVT1A on the wall, please follow the instructions below for removing the stand base.

To remove the stand base

1. Unplug all of the cables and cords from your SV470XVT1A.
2. Place the SV470XVT1A face down on a soft and flat surface (blanket, foam, cloth, etc) to prevent any damage to the TV.
3. Remove the total of eight (8) screws holding the base to the SV470XVT1A.
4. Carefully remove the stand base, pulling the base towards you.

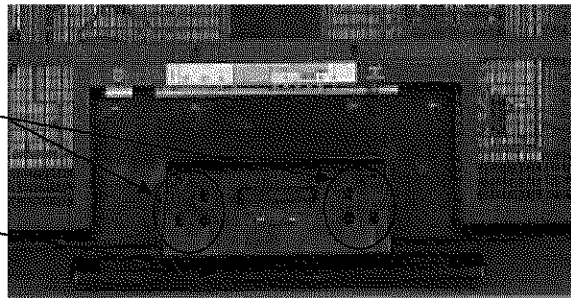

Now, the SV470XVT1A can fit securely to a mount (sold separately) by utilizing the mounting holes in the center of the back panel of the TV. Please make sure to read the instructions of your specific mount to properly hang the SV470XVT1A.

The pitch of the mounting holes is 600mm horizontally and 200mm vertically.

The screw type required is metric M8, 1.25mm pitch. The length of the screws will depend on the thickness plate being attach to the TV set; our brackets come with different length screws.

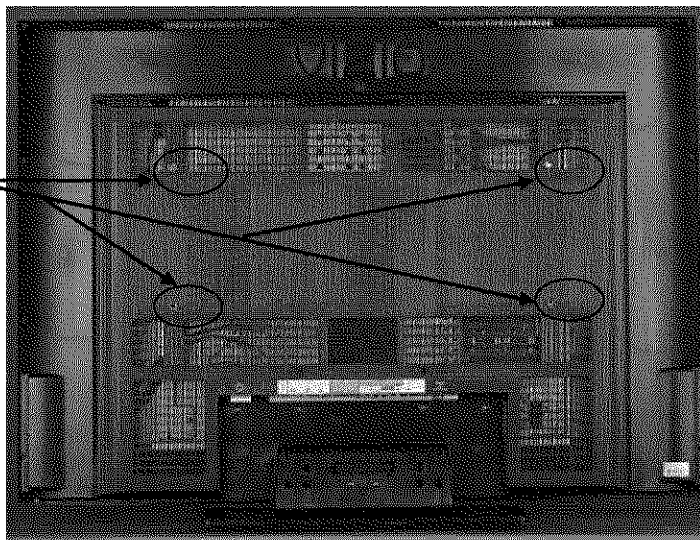

To find the perfect mount for the VIZIO SV470XVT1A, browse VIZIO's certified mount selection at www.VIZIO.com or call directly 888-VIZIOCE (888-849-4623).



Table of Contents

- Chapter 1 Basic Controls and Connections 10**
 - 1.1 Front Bezel 10
 - 1.2 Right Side Panel Controls 10
 - 1.3 Rear Panel Connections 11
 - 1.4 Right-Side Panel Connection 12
 - 1.5 VIZIO Universal Remote Control 13
 - 1.5.1 Insertion of Batteries in the Remote Control 16
 - 1.5.2 Remote Control Range 16
 - 1.5.3 VIZIO Universal Remote Control Precautions 16
- Chapter 2 Connecting Equipment 17**
 - 2.1 Which Video Connection Should I Use? 17
 - 2.2 Connecting Your Cable or Satellite Box 18
 - 2.2.1 Using HDMI 18
 - 2.2.2 Using Component Video 20
 - 2.3 Connecting Coaxial (RF) 21
 - 2.3.1 Using Your Antenna or Digital Cable for DTV 21
 - 2.3.2 Using Your Antenna or Cable for TV 22
 - 2.3.3 Using the Antenna or Cable through your VCR 22
 - 2.4 Connecting Your DVD Player 23
 - 2.4.1 Using HDMI 23
 - 2.4.2 Using Component Video 25
 - 2.4.3 Using S-Video (AV1) 26
 - 2.4.4 Using Composite (AV) Video 27
 - 2.5 Connecting Your VCR or Video Camera 28
 - 2.6 Connecting an external Receiver/Amp 29
 - 2.6.1 Optical Output of Audio received with HD Programs 29
 - 2.7 Connecting a PC Computer 30
 - 2.7.1 Preset PC Resolutions 31
 - 2.7.2 Resolution (1920x1080) through RGB (15-Pin VGA) Input 31
- Chapter 3 Setting Up to Watch Television 32**
 - 3.1 Basic LCD HDTV Start Up 32
 - 3.2 Watching a TV Program 36
 - 3.3 Adjusting Basic HDTV Settings 37
 - 3.4 Program Information 38
- Chapter 4 Advanced Adjustment of HDTV 39**
 - 4.1 Using the On Screen Display (OSD) 39
 - 4.2 DTV / TV Input Picture Adjustment 40
 - 4.2.1 Picture Mode 40
 - 4.2.2 Backlight 40
 - 4.2.3 Brightness 40
 - 4.2.4 Contrast 41
 - 4.2.5 Color 41
 - 4.2.6 Tint 41
 - 4.2.7 Sharpness 42
 - 4.2.8 Advanced Video Features 42
 - 4.2.9 Reset Picture Mode 45
 - 4.3 DTV / TV Audio Adjustment 46
 - 4.3.1 Audio Mode 46
 - 4.3.2 Equalizer 46
 - 4.3.3 Balance 46
 - 4.3.4 Digital Audio Out 47
 - 4.3.5 Speakers 47
 - 4.3.6 Analog Audio Out 47
 - 4.3.7 Lip Sync 47
 - Added Audio (Sound) Features 48
 - 4.3.8 Wireless Speaker 48
 - 4.3.9 Speaker Setting 48
 - 4.3.10 Wireless Sound Effect 50



4.3.11 Sound Effect	50
4.3.12 DRC (Dynamic Range Compression)	51
4.3.13 Reset Audio Mode	51
4.4 DTV / TV Tuner Setup	52
4.4.1 Tuner Mode	52
4.4.2 Auto Search	52
4.4.3 Partial Channel Search	53
4.4.4 Skip Channel	53
4.4.5 MTS	53
4.4.6 Time Zone	54
4.4.7 Daylight Saving	54
4.5 DTV / TV Input Setup	55
4.5.1 Language	55
4.5.2 PIP (Picture-in-Picture)	55
4.5.3 Sleep Timer	57
4.5.4 Wide	57
4.5.5 Input Naming	58
4.5.6 CC (Closed Caption)	59
4.5.7 H/V Position	60
4.5.8 DTV / TV Input Parental Control	61
4.5.9 Channel Block	62
4.5.10 US TV Rating	62
4.5.11 US Movie Rating (For US)	63
4.5.12 Canadian English Rating	63
4.5.13 Canadian French Rating	64
4.5.14 Check for DTV Rating	64
4.5.15 Blocked Unrated Programming	65
4.5.16 Change the Password	65
4.5.17 Reset All Settings	66
4.6 HDMI Input Picture Adjustment	67
4.7 HDMI Input Audio Adjustment	67
4.8 HDMI Input Setup	67
4.9 Video Input Picture Adjustment	68
4.10 Video Input Audio Adjustment	68
4.11 Video Input Setup	68
4.12 Auto Phase (for Component input)	69
4.13 Video Input Parental Control	69
4.14 PC Input Picture Adjustment	70
4.14.1 Auto Adjust	70
4.14.2 H-Position	70
4.14.3 V-Position	70
4.14.4 H-SIZE	71
4.14.5 V-SIZE	71
4.14.6 Fine Tune	71
4.15 PC Input Audio Adjustment	72
4.16 PC Input Setup	72
4.17 Understanding Viewing Features	73
4.17.1 Viewing Modes	73
4.17.2 Picture-In-Picture (PIP) Mode	74
4.17.3 Adjusting Basic PIP Settings	74
Programming the VIZIO Universal Remote Control	75
4.17.4 Programming for VCR	75
4.17.5 Programming for Cable Set-Top Box	75
4.17.6 Programming for DVD Player	76
4.17.7 Searching for Component Codes	76
4.18 Using a Cable or Satellite Remote	76
Chapter 5 Maintenance and Troubleshooting	77
5.1 Maintenance	77
5.2 Troubleshooting Guide	77
5.3 Wireless Speakers System and TV Pairing	79
5.4 Telephone & Technical Support	79
5.5 Compliance	80



5.6 FCC Class B Radio Interference Statement 80

Chapter 6 Miscellaneous Information 81

6.1 Specifications 81

6.2 Glossary – Standard Definitions 82

6.3 Index 83

Component Program Codes..... 89



Chapter 1 Basic Controls and Connections

1.1 Front Bezel

POWER 'VIZIO' LIGHT– The VIZIO name lights white when powered on and orange when powered off.

REMOTE CONTROL SENSOR – This is the window through which all of the remote control signals pass to the sensor. Point the remote control directly at this window for the best response to the remote signal.

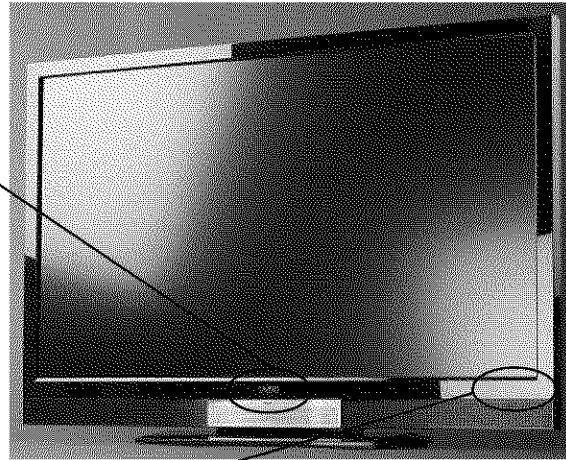

1.2 Right Side Panel Controls

POWER () – Switch the SV470XVT1A on by pressing the button once. Press the button again to turn the SV470XVT1A off.

MENU – This button activates the On Screen Display (OSD). If a sub-menu is active, pressing this button will return to the previous menu level.

CHANNEL +/- – Use these buttons to step up or down the TV channels. While the OSD is active, these buttons function as up and down controls in the OSD menus.

VOLUME +/- – Use these buttons to increase or decrease to the speaker volume. While the OSD is active, these buttons function as left and right controls in the OSD menus.

INPUT (ENTER) – Repeated pressing of this buttons steps through the input sources in the following sequence: TV, AV1, AV2 (S-Video), Component 1, Component 2, RGB, HDMI1, HDMI2, HDMI3 and HDMI4. Once you have stepped through the entire sequence, you will return to the beginning.

Additionally, when the OSD is active, this button confirms the menu function to be adjusted. When the OSD is not active, this button will show the current input selections.

TX INPUT – This slot is used only when upgrading your TV to Dolby Digital 5.1 wireless surround system. **Do not insert any object into the slot which may compromise the integrity and functionality of your TV. The manufacturer's warranty does not cover user abuse or improper use of this input.**

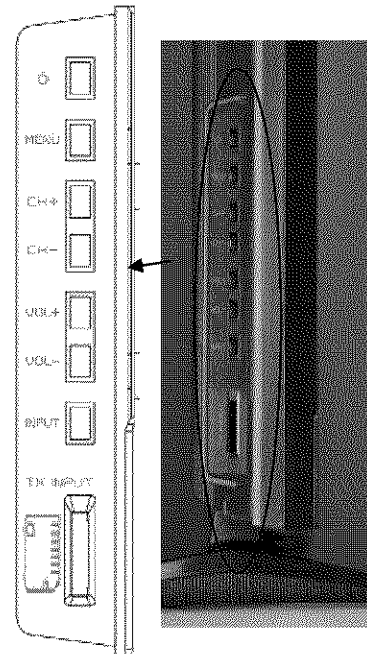

1.3 Rear Panel Connections

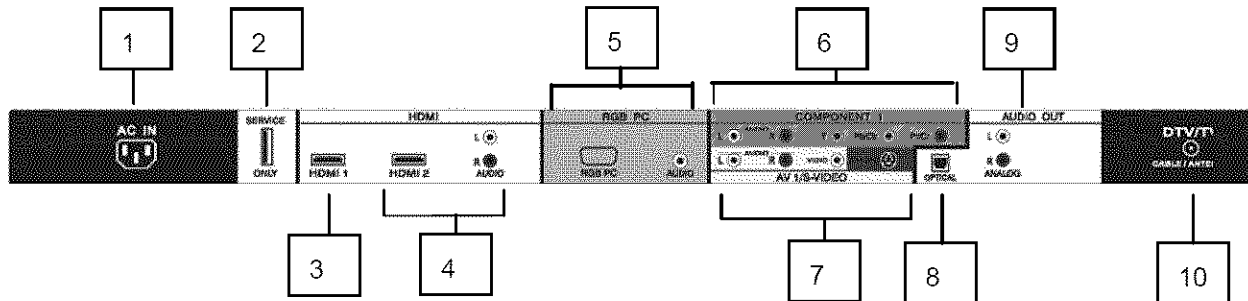

1. **AC IN** – Plug-in the supplied AC Power Cord here.
2. **SERVICE** – This custom communication port is for factory service only. **Use of this input for any purpose other than factory authorized service will void the manufacturer's warranty of this equipment.**
3. **HDMI 1** – Connect the primary source for digital video such as a DVD multimedia player or set top box through this all digital connector. The white color band on the rear of the TV indicates this connection.
4. **HDMI 2** – Connect a secondary source for digital video such as a DVD multimedia player or set top box through this all digital connector. The white color band on the rear of the TV indicates this connection. For users who want to connect to a DVI enabled device, use a DVI-HDMI cable and connect the Analog Audio output of the device to the L+R AUDIO here. Your VIZIO Certified HDMI and HDMI-DVI cables are available for purchase from www.VIZIO.com or by calling 888-VIZIOCE (888-849-4623).
5. **RGB PC** – Connect the video and audio from a computer here. The blue color band on the rear of the TV indicates this connection. A cable with a 1/8" mini plug stereo connector at the end connecting to the TV is needed if sound is also transmitted with this signal.
6. **COMPONENT 1 (YPb/CbPr/Cr with Audio L/R)** – Connect the primary source for component video devices such as a DVD Player or set top box here. From left to right, use white for left audio and red for right audio, green for Y, blue for Pb (or Cb), and red for Pr (or Cr) inputs. The green color band on the rear of the TV indicates this connection.
7. **AV1/S-VIDEO IN** – Connect the primary source for composite video devices, such as a VCR or video game. Use the white and red connectors to connect the external audio from the same source. The yellow color band on the rear of the TV indicates this connection.
8. **OPTICAL AUDIO OUT** – When the DTV input is selected for viewing, the audio associated with the programming will be available on this SPDIF Optical connector for connection to your home theatre system. The white color band on the rear of the TV indicates this connection.
9. **ANALOG AUDIO OUT** – Connect the audio from the LCD HDTV to an external device, such as a home theatre system, external amplifier or stereo. Speakers can not be connected directly to here. The white color band on the rear of the TV indicates this connection.
10. **DTV/TV** – Connect to an antenna or digital cable (no Cable Box) for Digital TV.*

* For digital TV stations in your area visit www.antennaweb.org.



1.4 Right-Side Panel Connection

1. **AV2** – Connect the secondary source for composite video devices, such as a VCR or video game. Use the white and red connectors to connect the external audio from the same source, and then use

the yellow connector to connect the external video from the same source. Note: The red and white audio connectors are shared between AV2 and COMPONENT2.

2. **COMPONENT2 (YPb/CbPr/Cr with Audio L/R)** - Connect the secondary source for component video devices such as a DVD

Player or set top box here. From top to bottom, left to right, use green for Y, blue for Pb (or Cb), red for Pr (or Cr), then connect white for left audio and red for right audio inputs. Note: The red and white audio connectors are shared between AV2 and COMPONENT2.

3. **HDMI 3** - Connect the third source for digital video such as a DVD multimedia player or set top box through this all digital connector.

4. **HDMI 4** - Connect the third source for digital video such as a DVD

multimedia player or set top box through this all digital connector.

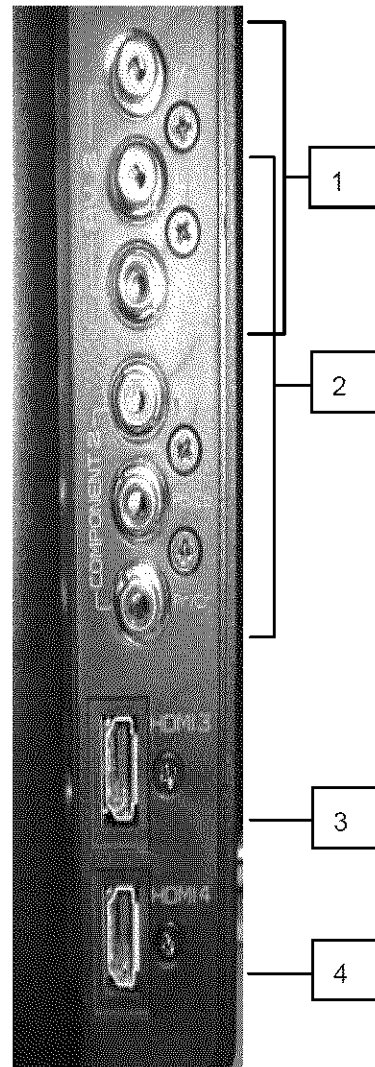

Certified HDMI and HDMI-DVI cables are available for purchase from www.VIZIO.com or by calling 888-VIZIOCE (888-849-4623)



1.5 VIZIO Universal Remote Control

The VIZIO Universal Remote Control is a comprehensive remote that can be used to control up to four different components. The remote button functions are explained on the following pages.



This button starts all programming of the Remote Control.



Press this button to turn the TV on from the Standby mode. Press it again to return to the Standby mode.



Repeated pressing of this button will switch between HDMI 1, HDMI 2, HDMI 3 and HDMI 4 inputs.



Repeated pressing of this button will switch between Component 1 and Component 2 inputs



Repeated pressing of this button will switch between AV1 and AV2 inputs.



Press this button to select TV programming.



Use these buttons to select a channel or enter a password.



This button allows the user to cycle through the inputs.



This DASH button is for the DTV mode. When selecting a digital channel directly use this button for the separation of main and sub-channels. For example, channel 28-2 would be selected by the button sequence 2 8 DASH 2.

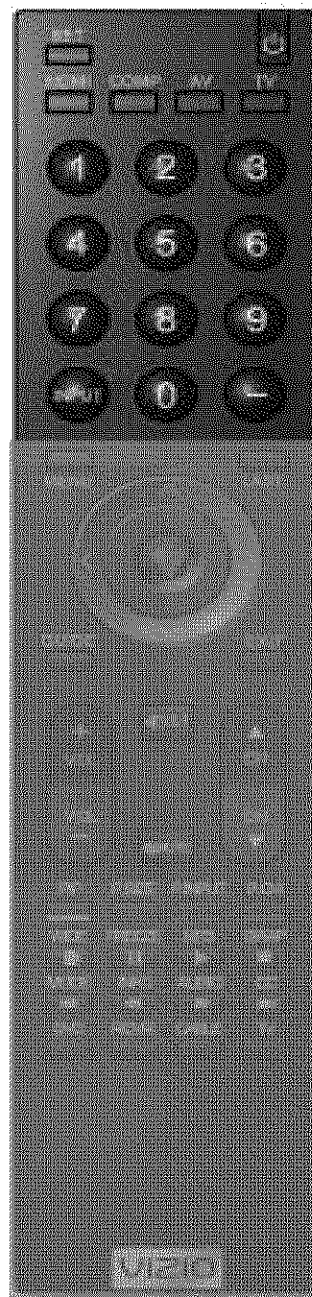

NOTE: This is a programmable remote supporting up to 4 devices (see TV, VCR, CABLE, DVD buttons at the top of the remote). If the remote is not working with your VIZIO TV, press the TV button on the remote to set the functions back to TV.





Use this button for the On-Screen Display (OSD) menus.



LAST – This button recalls the previously viewed channel.

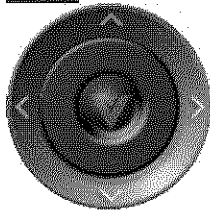

Use the Navigation Wheel to operate the On-Screen Display (OSD) after it has been activated by pressing the MENU button.



Use the button to select your chosen option in On-Screen Display (OSD) menus.



GUIDE – This button displays program information. Note: This function is only available on DTV.



EXIT – This button exits the On-Screen Display (OSD) menus.



VOL (+ or -) – These buttons turn the volume up or down.



5.1 Surround Sound - This function is not available on this model and pressing this button has no effect, unless wireless speaker system is present.



MUTE – This button turns the sound on and off.



CH (+ or -) – These buttons change the channels up or down.

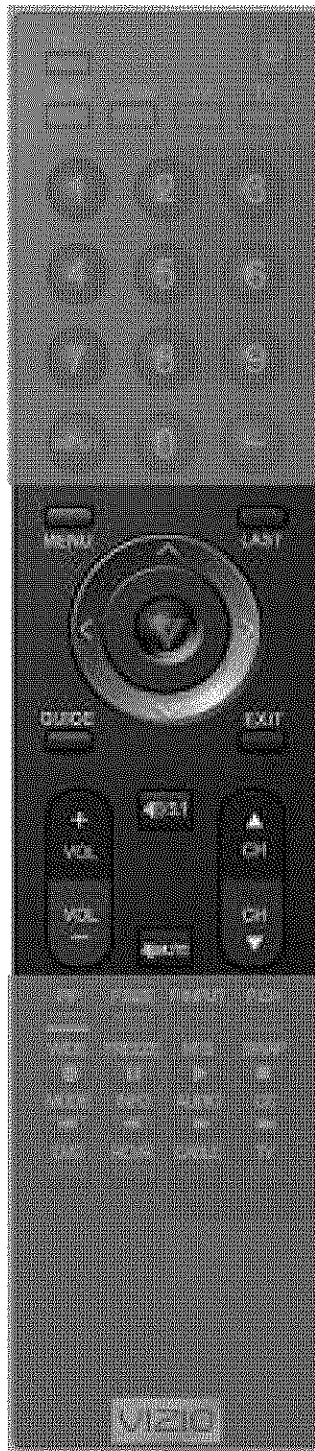



When CABLE is selected and the code to match your Cable (or Satellite) Box has been entered, this button will operate the Cable (or Satellite) Box the same as this button on your Cable (or Satellite) Remote. When TV is selected, this button activates Picture-in-Picture mode.



When CABLE is selected and the code to match your Cable (or Satellite) Box has been entered, this button will operate the Cable (or Satellite) Box the same as this button on your Cable Remote.

When TV is selected, press this button to select the size of the PIP screen from one of the following: small, medium or large



When CABLE is selected and the code to match your Cable Box (or Satellite) has been entered, this button will operate the Cable Box (or Satellite) the same as this button on your Cable Remote (or Satellite). When TV is selected, press the button to choose the PIP input.

Note: The TV must be in PIP mode for this button to be functional.



When CABLE is selected and the code to match your Cable Box (or Satellite) has been entered, this button will operate the Cable Box (or Satellite) the same as this button on your Cable Remote (or Satellite). When TV is selected, this button is used to select the channels within the PIP screen when DTV/TV is the PIP input selected



This button cycles through the available screen formats. The options are Zoom, Panoramic, Normal and Wide.



Press this button to "Freeze-Frame" the current screen. Press this button again to continue playing.



This button will select the MTS options of Stereo, SAP or Mono in standard TV mode and alternate audio channels, where available, in DTV mode.



While in PIP/POP mode; pressing SWAP will switch the displays from the main screen to the sub-screen or vice versa.



Use this button to change the picture mode from Custom, Standard, Movie and Game



This button displays the image and system information display.



Press this button to switch the audio from the main screen to the sub-screen while in PIP or POP mode.



This button will select the Closed Caption mode. The options are OFF, CC1, CC2, CC3, and CC4 and if Digital Cable Service is the signal; you would get Service1 through Service6, depending on your local company.



This button selects a programmed DVD player.



This button selects a programmed Audio Receiver/Amp/Home Theater System.



This button selects a programmed cable TV set-top box or a satellite TV set-top box.



This button has been pre-programmed to select the codes to operate the VIZIO HDTV.

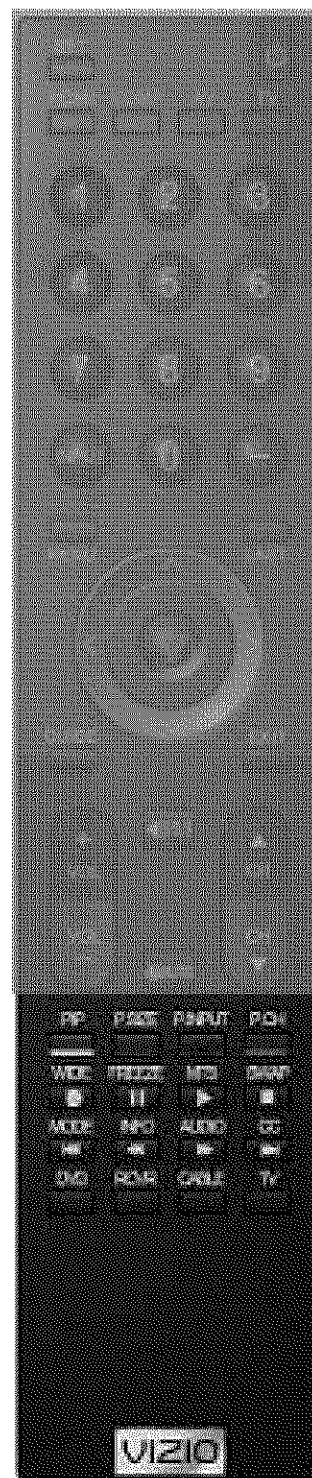

1.5.1 Insertion of Batteries in the Remote Control

Open battery compartment by sliding cover in the direction of the arrow and insert two AAA batteries into the remote control. Make sure that you match the (+) and (-) symbols on the batteries with the (+) and (-) symbols inside the battery compartment. Close the battery cover by sliding it in opposite direction to the arrow.

Precautionary Tips for Inserting the Batteries:

For longer life and use of the batteries, please use alkaline.

Only use the specified AAA batteries.

Do not mix new and old batteries. This may result in cracking or leakage that may pose a fire risk or lead to personal injury.

Inserting the batteries incorrectly may also result in cracking or leakage that may pose a fire risk or lead to personal injury.

Dispose of the batteries in accordance with local laws and regulations.

Keep the batteries away from children and pets.

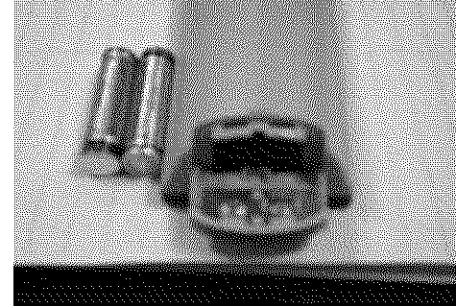

1.5.2 Remote Control Range

Point the remote control at the remote control sensor to transmit the commands.

Do not place any obstacles between the remote control and the receiver window.

The effective range of the remote control is approximately 30 feet (10 meters) from the front of the receiver window, 30° to the left and right, 20° up and down.

1.5.3 VIZIO Universal Remote Control Precautions

The remote control should be kept dry and away from heat sources. Avoid humidity.

If the TV responds erratically to the remote control or does not respond at all, check the batteries. If the batteries are low or exhausted, replace them with fresh batteries.

When not using the remote control for a long period of time, remove the batteries.

Do not take the batteries apart, heat them, or throw them into a fire.

Do not subject the remote control to undue physical stress, such as striking or dropping it.





Do not attempt to clean the remote control with a volatile solvent. Wipe it with a clean, damp cloth.



Chapter 2 Connecting Equipment

2.1 Which Video Connection Should I Use?

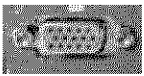
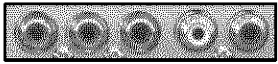
The VIZIO SV470XVT1A has six different ways to connect your video equipment from a basic connection to the most advanced for digital displays.

Connection Quality (type)	Connector	Rear Panel Color Codes	Description
Best (digital)		White and Side of TV	HDMI (High-Definition Multimedia Interface) - It is the first and only industry-supported, uncompressed, all-digital audio/video interface. HDMI provides an interface between any audio/video source, such as a set-top box, DVD player, or A/V receiver and an audio and/or video monitor, such as a digital television (DTV), over a single cable.
Best (digital) ----- Good (analog)		Black	DTV Coaxial RF. When used for MPEG2 encoded bit streams from ATSC broadcast programming, this input takes advantage of the High Definition content. ----- TV Coaxial RF. This is the connection for standard NTSC TV using antenna or cable.
Best (analog)		Blue	RGB PC (VGA) – This video input has separate red, green and blue color components. The signal carries horizontal and vertical sync information on the green signal. This is most commonly used for PC input.
Better (analog)		Green and Side of TV	Component 1/2 - The video signal is separated into three signals, one containing the black-and-white information and the other two containing the color information. This enhancement over S-Video takes advantage of the superior picture provided by progressive scan DVD players and HDTV formats.
Good (analog)		Red	S-Video (AV1) - The video signal is separated into two signals, one containing the black-and-white information and the other containing the color information. Separating the color in this way avoids 'cross color' effects where closely spaced black and white lines are erroneously displayed in color. It also enables text to be displayed more sharply.
Good (analog)		Yellow and Side of TV	AV1/2(Composite) - The complete video signal is carried through this single pin connector. This is the most commonly used video connection.

Note: For more info refer to the Quick Start Guide



2.2 Connecting Your Cable or Satellite Box

2.2.1 Using HDMI

Cable and Satellite Boxes that have a HDMI digital interface should be connected to the HDMI input of the LCD HDTV for optimal results.

Note: To maintain the display quality, use a VIZIO certified HDMI cable. Length is available up to 10 meters. See www.vizio.com or call 1-888-VIZIOCE (1-888-849-4623) for details.

Connecting your Cable or Satellite Box (Best)

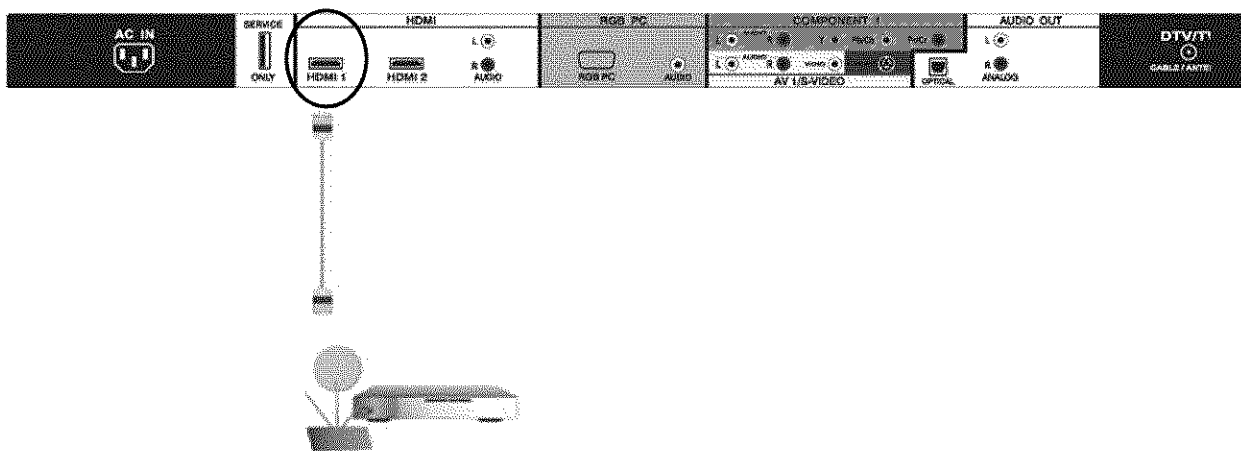

1. Turn off the power to the LCD HDTV and HDTV Set-Top Box.
2. Connect a HDMI cable to the HDMI output of your HDTV Set-Top Box and the other end to the HDMI Input (white color area) at the rear of the LCD HDTV.
3. Turn on the power to the LCD HDTV and HDTV Set-Top Box.
4. Select HDMI using the INPUT button on the remote or side of the LCD HDTV, or directly by pressing the HDMI button on the Remote Control.

Note:

- a) The HDMI input on the LCD TV supports High-bandwidth Digital Content Protection (HDCP). HDCP encrypts the transmission between the video source and the digital display for added security and protection.
- b) If you are already using the HDMI1 input for another component, or you do not want to use the HDMI1 input for the Set-Top Box, you can connect the Set-Top Box to the HDMI2, HDMI3 or HDMI4 connection.
- c) Refer to your HDTV Set-Top Box user manual for more information about the video output requirements of the product or consult your cable or satellite operator.



For Cable or Satellite Boxes with DVI:

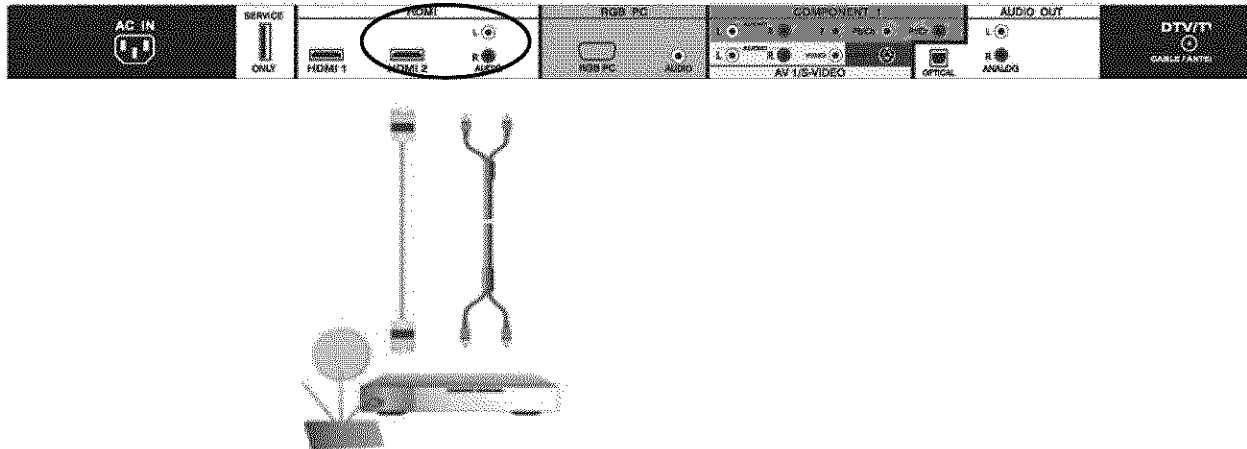

1. Turn off the power to the LCD HDTV and HDTV Set-Top Box.
2. Using a HDMI-DVI cable, connect the DVI end to your HDTV Set-Top Box and the HDMI end to the HDMI2 Input (white color area) at the rear of the LCD HDTV.
3. Using an audio cable (white and red connectors), connect the cable to the audio output connectors associated with the DVI output on your HDTV Set-Top Box and connect the other end to the audio connectors associated with the HDMI input (white area) at the rear of the LCD HDTV.
4. Turn on the power to the LCD HDTV and HDTV Set-Top Box.
5. Select HDMI2 using the INPUT button on the remote or side of the LCD HDTV, or directly by pressing the HDMI button on the Remote Control.

Note:

- d) The HDMI input on the LCD TV supports High-bandwidth Digital Content Protection (HDCP). HDCP encrypts the transmission between the video source and the digital display for added security and protection.
- e) If you are already using the HDMI2 input for another component, or you do not want to use the HDMI2 input for the Set-Top Box, you can connect the Set-Top Box to the HDMI1, HDMI3 or HDMI4 connection. The LCD TV will recognize the DVI connection and obtain audio information from the audio connectors near HDMI2 input.
- f) Refer to your HDTV Set-Top Box user manual for more information about the video output requirements of the product or consult your cable or satellite operator.



2.2.2 Using Component Video

Connecting your Cable or Satellite Box (Better)

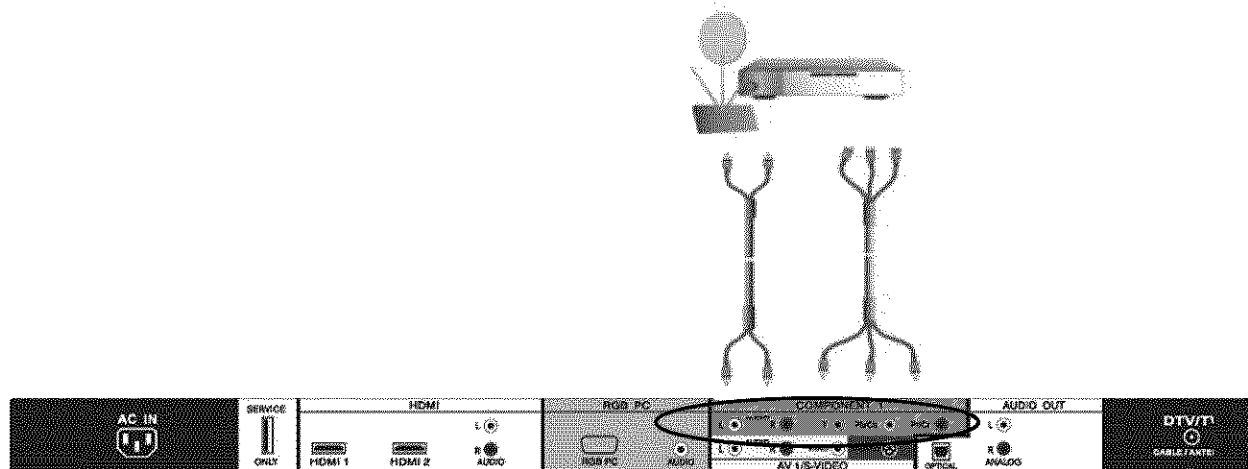

1. Turn off the power to the LCD HDTV and HDTV Set-Top Box.
2. Connect the Y (green color) connector on your HDTV Set-Top Box to the corresponding Y (green color) connector in the Component 1 group (green color area - row of connectors nearest to you when viewing from the rear of the TV) at the rear of the LCD HDTV.
3. Connect the PbCb (blue color) connector on your HDTV Set-Top Box to the corresponding Pb (blue color) connector in the Component 1 group (green color area - row of connectors nearest to you when viewing from the rear of the TV) at the rear of the LCD HDTV.
4. Connect the PrCr (red color) connector on your HDTV Set-Top Box to the corresponding Pr Cr (red color) connector in the Component 1 group (green color area - row of connectors nearest to you when viewing from the rear of the TV) at the rear of the LCD HDTV.
5. Using an audio cable (white and red connectors), connect the cable to the audio output connectors associated with the Component output on your HDTV Set-Top Box and connect the other end to the audio connectors associated with the Component 1 input (green color area) at the rear of the LCD HDTV.
6. Turn on the power to the LCD HDTV and HDTV Set-Top Box.
7. Select Component 1 using the INPUT button on the remote or side of the LCD HDTV, or directly by pressing the COMP button on the Remote Control.

Note:

- a) If you are already using the Component 1 input for another component, or you do not want to use the Component 1 input for the Set-Top Box, you can connect the Set-Top Box to the Component 2 connections on the side of the TV.
- b) Refer to your HDTV Set-Top Box user manual for more information about the video output requirements of the product or consult your cable or satellite operator.



2.3 Connecting Coaxial (RF)

2.3.1 Using Your Antenna or Digital Cable for DTV

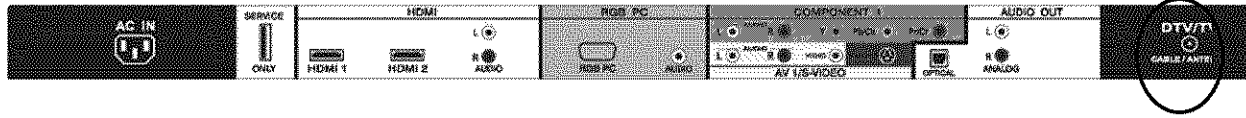

1. Turn off the power to the LCD HDTV.
2. Connect the coaxial (RF) connector from your antenna or digital cable to the DTV/TV CABLE/ANTENNA connector at the rear of the LCD HDTV.
3. Turn on the power to the LCD HDTV.
4. Select DTV using the INPUT button on the remote or side of the LCD HDTV, or directly by pressing the TV button on the Remote Control.

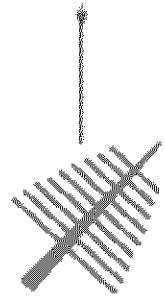

Note:

- a) Not all digital TV broadcasts are High Definition (HD). Refer to the program guides, or consult your cable, satellite or TV station operator.
- b) Digital broadcasts are not available in all areas. Refer to www.antennaweb.org for detailed information.
- c) Make sure the antenna and coaxial cable are correctly grounded.



2.3.2 Using Your Antenna or Cable for TV

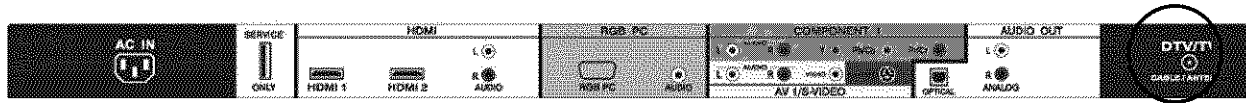

1. Turn off the power to the LCD HDTV.
2. Connect the coaxial (RF) connector from your antenna or cable to the DTV/TV CABLE/ANTENNA connector at the rear of the LCD HDTV
3. Turn on the power to the LCD HDTV.
4. Select TV using the INPUT button on the remote or side of the LCD HDTV, or directly by pressing the TV button on the Remote Control.

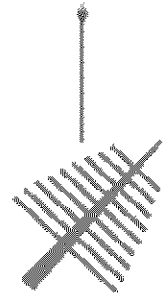

2.3.3 Using the Antenna or Cable through your VCR



1. Turn off the power to the LCD HDTV and VCR.
2. Connect the "Output to TV", "RF Out" or "Antenna Out" connector on the rear of your VCR to the DTV/TV CABLE/ANTENNA connector at the rear of the LCD HDTV.
3. Turn on the power to the LCD HDTV and VCR.
4. Select TV using the INPUT button on the remote or side of the LCD HDTV, or directly by pressing the TV button on the Remote Control.

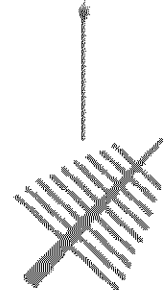

Note: If you have an off-air antenna or cable TV, connect it to the "Antenna In" connector on the rear of your VCR.



2.4 Connecting Your DVD Player

You have several options for connecting your DVD player to your SV470XVT1A – HDMI, Component, S-Video and Composite (AV) inputs. Based on your home theater configuration, you can decide which option is the right one for you.

2.4.1 Using HDMI

DVD players that have a digital interface such as HDMI (High Definition Multimedia Interface) should be connected to the HDMI input of the VIZIO SV470XVT1A for optimal results.

Note: To maintain the display quality, use a VIZIO certified HDMI cable. Length is available up to 10 meters. See www.VIZIO.com or call 1-888-VIZIOCE (1-888-849-4623) for details.

Connecting your DVD Player (Best):

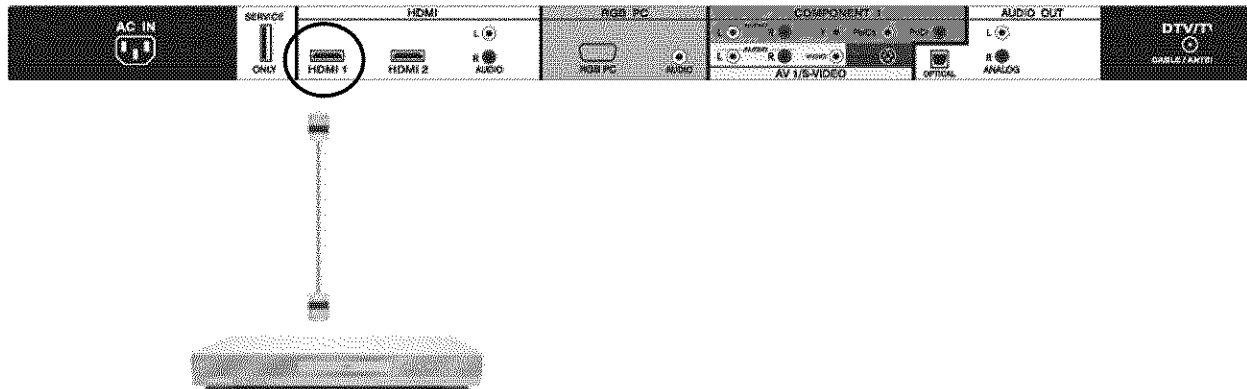

1. Turn off the power to the LCD HDTV and DVD player.
2. Connect a HDMI cable to the HDMI output of your DVD player and the other end to the HDMI Input (white color area) at the rear of the LCD HDTV.
3. Turn on the power to the LCD HDTV and your DVD player.
4. Select HDMI using the INPUT button on the remote or side of the LCD HDTV, or directly by pressing the HDMI button on the Remote Control.

Note:

- a) If you are already using the HDMI1 input for another component, or you do not want to use the HDMI 1 input for the DVD player, you can connect the DVD player to the HDMI2, HDMI3 or HDMI4 connection.
- b) Refer to your DVD player user manual for more information about the video output requirements of the product.



For DVD Players with DVI:

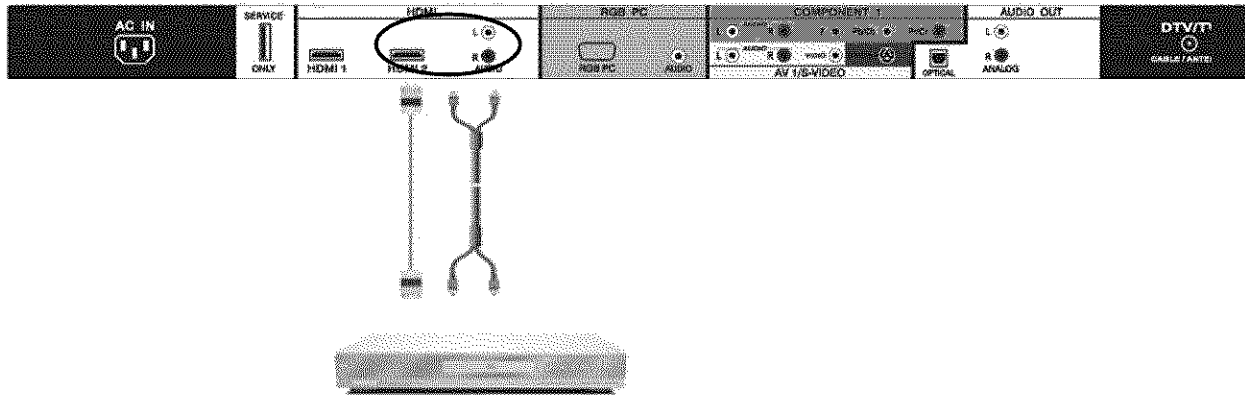

1. Turn off the power to the LCD HDTV and DVD player.
2. Using a HDMI-DVI cable, connect the DVI end to your DVD player and the HDMI end to the HDMI2 Input (white color area) at the rear of the LCD HDTV.
3. Using an audio cable (white and red connectors), connect the cable to the audio output connectors associated with the DVI output on your DVD player and connect the other end to the audio connectors associated with the HDMI input (white area) at the rear of the LCD HDTV.
4. Turn on the power to the LCD HDTV and your DVD player.
5. Select HDMI 2 using the INPUT button on the remote or side of the LCD HDTV, or directly by pressing the HDMI button on the Remote Control.

Note:

- a) If you are already using the HDMI2 input for another component, or you do not want to use the HDMI 2 input for the DVD Player, you can connect the DVD player to the HDMI1, HDMI3 or HDMI4 connection. The LCD TV will recognize the DVI connection and obtain audio information from the audio connectors near HDMI2 input.
- b) Refer to your DVD player user manual for more information about the video output requirements of the product.



2.4.2 Using Component Video

Connecting your DVD Player (Better):

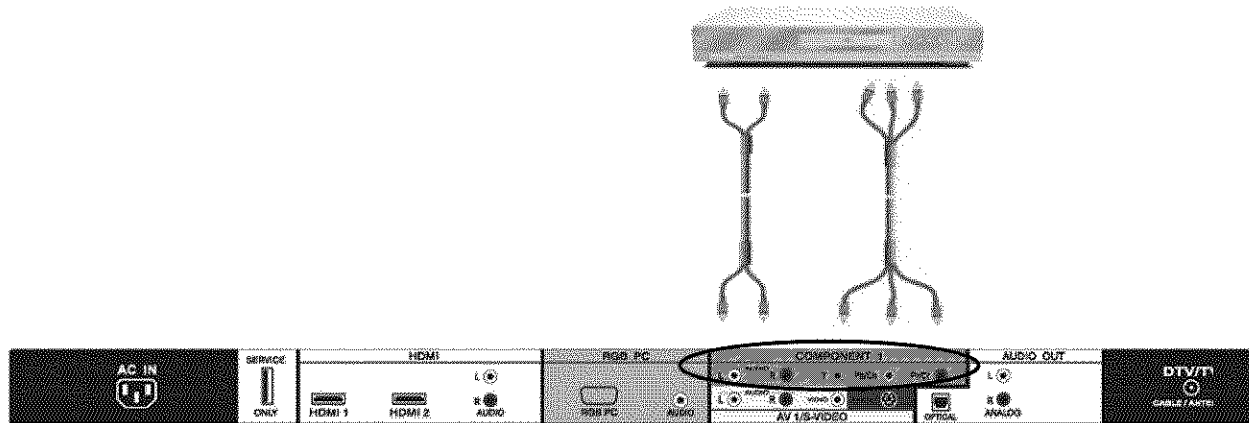

1. Turn off the power to the LCD HDTV and DVD player.
2. Connect the Y (green color) connector on your DVD player to the corresponding Y (green color) connector in the Component 1 group (green color area - row of connectors nearest to you when viewing from the rear of the TV) at the rear of the LCD HDTV.
3. Connect the PbCb (blue color) connector on your DVD player to the corresponding PbCb (blue color) connector in the Component 1 group (green color area - row of connectors nearest to you when viewing from the rear of the TV) at the rear of the LCD HDTV.
4. Connect the PrCr (red color) connector on your DVD player to the corresponding PrCr (red color) connector in the Component 1 group (green color area - row of connectors nearest to you when viewing from the rear of the TV) at the rear of the LCD HDTV.
5. Using an audio cable (white and red connectors), connect the cable to the audio output connectors associated with the Component output on your DVD player and connect the other end to the audio connectors associated with the Component 1 input (green color area) at the rear of the LCD HDTV.
6. Turn on the power to the LCD HDTV and DVD player.
7. Select Component 1 using the INPUT button on the remote or side of the LCD HDTV, or directly by pressing the COMP button on the Remote Control.

Note:

- a) If you are already using the Component 1 input for another component, or you do not want to use the Component 1 input for the DVD player, you can connect the DVD player to the Component 2 connections on the side of the TV.
- b) Refer to your DVD player user manual for more information about the video output requirements of the product.



2.4.3 Using S-Video (AV1)

Connecting your DVD Player (Good):

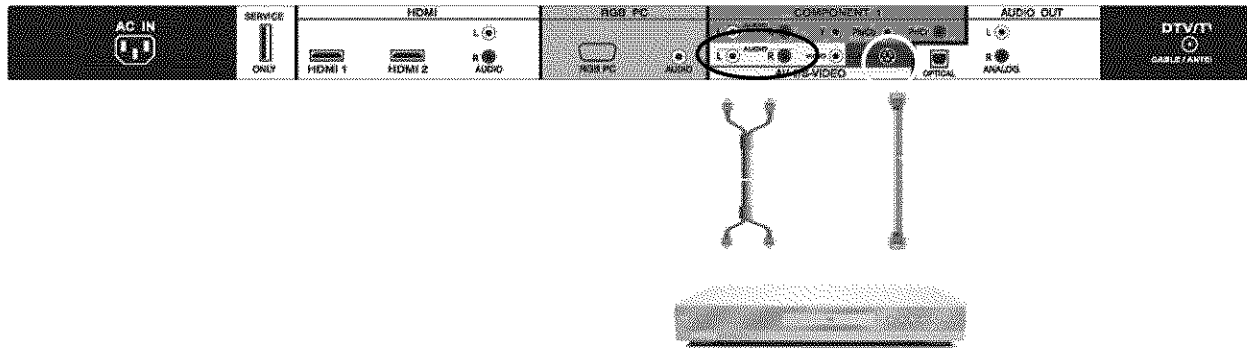

1. Turn off the power to the LCD HDTV and DVD player.
2. Connect the S-Video jack on the rear of your DVD player to the S-Video jack in the AV1 at the rear of the LCD HDTV.
3. Using an audio cable (white and red connectors), connect the cable to the audio output connectors associated with the S-Video output on your DVD player and connect the other end to the audio connectors associated with the AV1 input at the rear of the LCD HDTV.
4. Turn on the power to the LCD HDTV and DVD player.
5. Select AV1 using the INPUT button on the remote or side of the LCD HDTV, or directly by pressing the AV button on the Remote Control.

Note: Refer to your DVD player user manual for more information about the video output requirements of the product.



2.4.4 Using Composite (AV) Video

Connecting your DVD Player (Good):

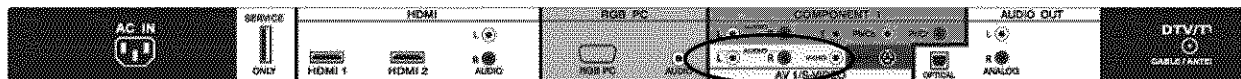
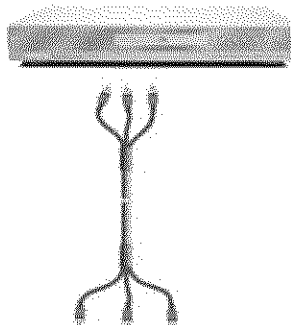

1. Turn off the power to the LCD HDTV and DVD player.
2. Connect the Video (yellow color) connector on your DVD player to the Video (yellow color) connector in the AV1 input row (yellow color area) of connectors at the rear of the LCD HDTV.
3. Connect the R (red color) and L (white color) audio connectors on your DVD player to the corresponding R (red color) and L (white color) audio input connectors in the AV input (yellow color area) row of connectors at the rear of the LCD HDTV.
4. Turn on the power to the LCD HDTV and DVD Player.
5. Select AV1 using the INPUT button on the remote or side of the LCD HDTV, or directly by pressing the AV button on the Remote Control.

Note:

Refer to your DVD player user manual for more information about the video output requirements of the product.



2.5 Connecting Your VCR or Video Camera

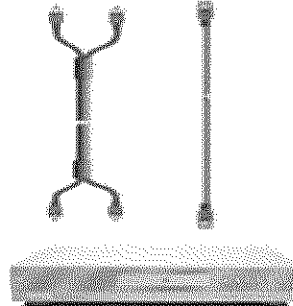
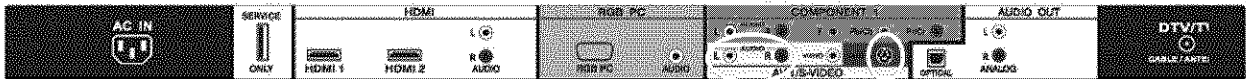

1. Turn off the power to the LCD HDTV and VCR or Video Camera.
2. Connect the S-Video jack on the rear of your VCR or Video Camera to the S-Video jack in the AV1 group (red area color) at the back of the LCD HDTV.
3. Using an audio cable (white and red connectors), connect the cable to the audio output connectors associated with the S-Video output on your VCR or Video Camera and connect the other end to the audio connectors associated with the AV1 input (red color area) at the rear of the LCD HDTV.
4. Turn on the power to the LCD HDTV and VCR or Video Camera.
5. Select AV1 using the INPUT button on the remote or side of the LCD HDTV, or directly by pressing the AV button on the Remote Control.

Note: Refer to your VCR or Video Camera user manual for more information about the video output requirements of the product.



2.6 Connecting an external Receiver/Amp

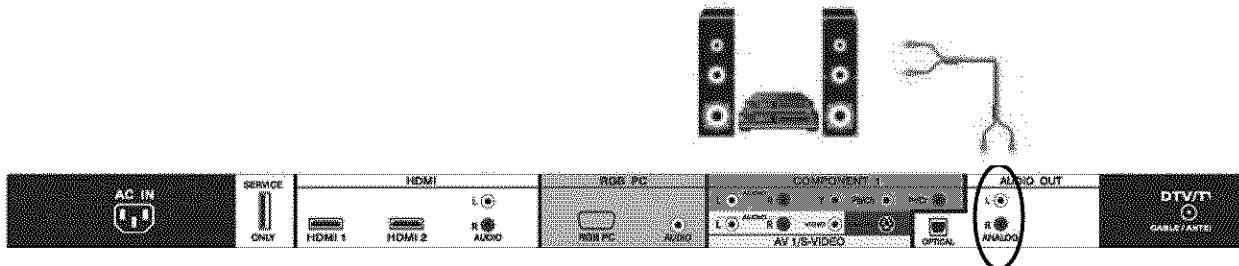

1. Turn off the power to the LCD HDTV and Receiver/Amp.
2. Using an audio cable (white and red connectors), connect the cable to the audio input connectors on the Receiver/Amp and connect the other end to the ANALOG OUT (white area) audio connectors at the rear of the LCD HDTV.
3. Turn on the power to the LCD HDTV and Receiver/Amp.
4. Then press the **MENU** button on the remote control to open the On-Screen Display (OSD) menu.
5. Press **▼** button on the remote control to select the Audio menu.
6. Press **●** on the remote control to select SPEAKERS.
7. Press **▶** on the remote control to select OFF so that the sound from the LCD HDTV will now be routed through your Receiver/Amp system.



Note:

- a) Refer to your Receiver/Amp user manual to select the corresponding audio input.
- b) The audio output is not amplified and cannot be connected directly to external speakers.

2.6.1 Optical Output of Audio received with HD Programs



If your sound system has a SPDIF (optical) digital audio input you can connect it to the optical DIGITAL AUDIO OUT (white area) at the rear of the LCD HDTV. This is active when receiving audio with the programs being viewed no matter what input is being used.



2.7 Connecting a PC Computer

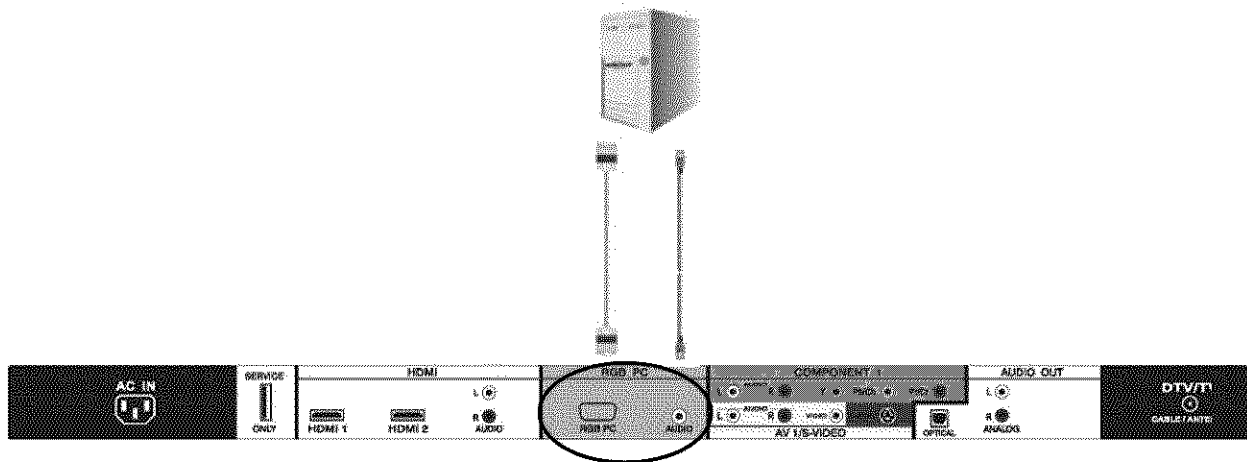

1. Turn off the power to the LCD HDTV and PC Computer.
2. Connect a 15-pin D-Sub RGB (VGA) cable to the RGB output of your pc computer and the other end to the RGB PC input (blue area) at the rear of the LCD HDTV.
3. Connect the Audio Out on your pc computer to the RGB PC Audio input (blue area) at the rear of the LCD HDTV.
4. Turn on the power to the LCD HDTV and PC Computer.
5. Select RGB using the INPUT button on the remote or side of the LCD HDTV.

Note:

- a) For a better picture quality when connecting a pc computer through RGB PC, set your pc computer timing mode to VESA 1366x768 at 60Hz. For the best picture quality, please refer to the pc or graphic card's user guide to find out if it is capable of an output of 1920x1080 at 60Hz resolution when using the parameters and values given to you on Section 2.7.2 of this User's Manual by way of VESA Reduce Blanking timing.
- b) Refer to your pc computer user manual for more information about the video output requirements of the product.
- c) A RGB (VGA) cable and stereo mini jack cable are not included and can be purchased at an electronics store.



2.7.1 Preset PC Resolutions

If connecting to a PC through the RGB PC input, set the TV timing mode to VESA 1360x768 at 60Hz for better picture quality (refer to the graphic card's user guide for questions on how to set this timing mode). Please see the table below for the factory preset resolutions. Also see chart in Section 2.7.2, for the best resolution that can be obtained through RGB PC input when video card supports 1920x1080 resolution.

Resolution	Refresh (Hz)	H.Freq (kHz)	V.Freq (Hz)	H.Sync	V.Sync	Pixel Freq (MHz)
640x480	60	31.46	59.94	N	N	25.17
640x480	75	37.50	75.00	N	N	31.50
*720x400	70	31.46	70.08	N	P	28.32
800x600	60	37.87	60.317	P	P	40.00
800x600	75	46.87	75	P	P	49.50
1024x768	60	48.36	60.01	N	N	65.00
1024x768	70	56.47	70.07	N	N	75.00
1024x768	75	60.02	75.03	P	P	78.75
**1920x1080	60	66.65	60.00	P	P	136.50

NOTES: N = Negative, P = Positive, * = In DOS Mode only, ** = Primary Mode. Please refer to 2.7.2 for more information.

2.7.2 Resolution (1920x1080) through RGB (15-Pin VGA) Input

If your PC supports VESA Reduce Blanking timing via the VGA card drive program (usually offered by the VGA Card Manufacturer), your TV set is equipped to have the 1920x1080 resolution display through this connection using the following timing 136.5MHz. The following parameters are often the values required by the software or programs to set up the display:

Parameters	Horizontal Values (Pixels)	Vertical Values (Lines)
Address	1920	1080
Front Porch	32	1
Sync Width	32	3
Back Porch	64	27
Total	2048	1111
Frequency	66.65 kHz	60 Hz
Sync Polarity	P	P
Pixel Rate (MHz)	136.5	
Refresh Rate (Hz)	60	



Chapter 3 Setting Up to Watch Television

For Preparing Your LCD HDTV for Wall Mounting; see page 6 for details.

3.1 Basic LCD HDTV Start Up

1. Connecting the Power Cable

Connect the power cord to the power cord connector on the back of the HDTV, and then plug the power cord into an AC wall socket.

2. Connect Audio and Video Cables to the HDTV

(see pages 17 ~ 30 for detailed steps)

3. Turning Power On

Once all the components are connected, press the Power ON button on the side of the HDTV, or press the Power ON (Red) button on the remote control.

4. Initial Setup

After powering on the TV set, the Initial Setup screen will come up; please press

the  button on the remote control.

The Language choice screen will be displayed; the default English option is highlighted. If you wish to change the OSD language to Español or Français, press the  button on the remote control to select the language you want.

Press the  button on the remote to go to the next screen.

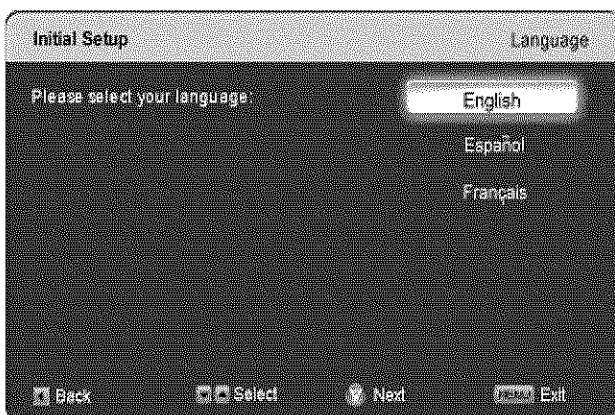
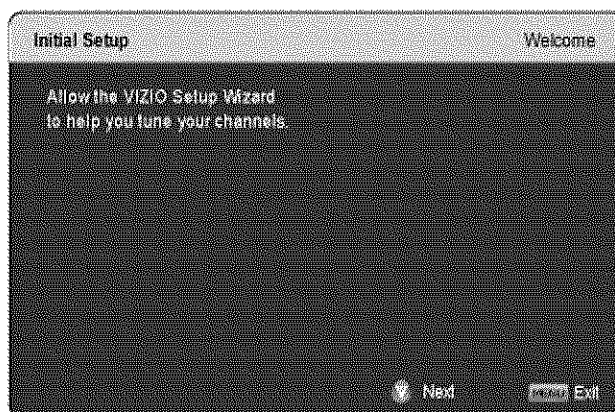

Note: At this point, if a Set-Top Box from your Local Cable or Satellite Service Company or other equipment is been used; please press the **EXIT** key on the remote control and skip to Step 5. If this is not your case, please continue at Step b.

- a. The Tuner screen will be displayed; default choice is Antenna. If you are using Cable (No Box) Service, press the  button on the remote control to highlight CABLE.

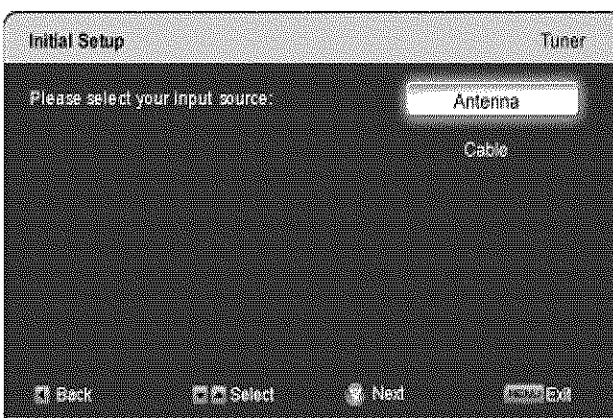



Press the  button on the remote to go to the next screen.

- b. The Channel Scan screen will be displayed; default choice is Scan.

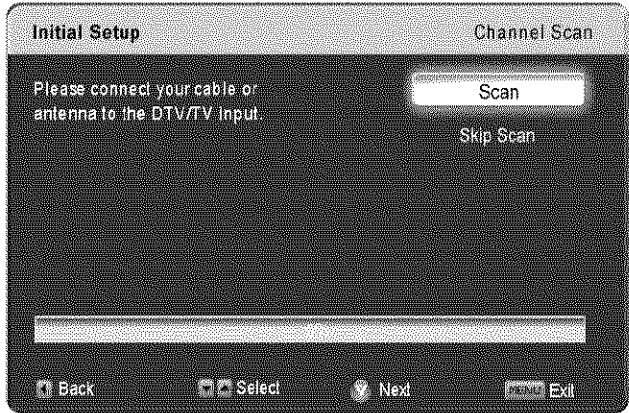
Press the  button on the remote control to commence the search for available channels to be stored into memory.



If you do not want to scan for channels at this time, press the  button on the remote to highlight Skip Scan and then press the  button.

Note: If you select Skip Scan, next time that you decide to complete this procedure; you will need to select the TV as input and then go through the Menu option to select the Tuner setup to get the option of scanning the channels again.

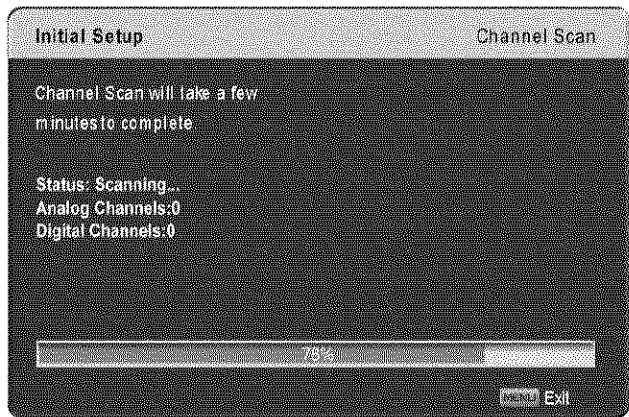

- c. The screen will now change to show the progress of the search for Analog (NTSC) and Digital (ATSC) channels.

Note: DTV digital broadcast is not available in all areas. Refer to www.antennaweb.org to get information about availability in your area, type of antenna and in which direction to point your antenna. The channel availability through cable depends upon which channels your cable operator supplies in Clear QAM; consult your cable operator for more information.



- d. When finished, the Complete screen will be displayed to inform you that the HDTV has completed the Initial Setup.

Press the  button on the remote control to exit and begin watching TV.



5. Select Input Source

Select the Input Source for the HDTV by pressing the INPUT button on the side of the TV or using the Input button on the remote control. Pressing this button will cycle you through the following options: TV, AV1/S-VIDEO, AV2, Component1, Component2, RGB, HDMI1, HDMI2, HDMI3 and HDMI4.

Now follow the procedure below to display channels from a different signal (External TV Tuner, VCR, Cable Box or Satellite Receiver) source, using different inputs at the back of you TV set.

a. Select the correct input connection; RF (DTV/TV) connector, Composite (Yellow, Red and White) connectors, Component (Red, Green, Blue plus Red and White) connectors, HDMI connectors or Separate-Video (S-Video) plus Red and White connectors (if applicable). Make the physical connection or hook up.

b. If you have an HD service you must use the HDMI (best) or Component connection.

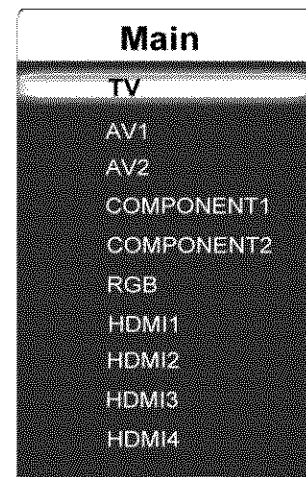

Note: Composite (AV) and S-Video Cables can only be used for SD (480i) pictures.

c. Turn on your Cable Box, VCR, External TV Tuner or Satellite Receiver and you will see a picture on your TV set. If there is not picture, make sure you have selected the correct input on the TV set.

d. If the selected input is RF, you should be aware that the TV set needs to be on either channel 3 or channel 4 matching the channel which has been selected on the back of the VCR, Cable Box, External TV Tuner or Satellite Receiver; please refer to Owner or User's Manual of such equipment for details.

Note: The TV set will be displaying any television station or program selected by the Cable Box, VCR, External Tuner or Satellite Receiver. The TV set will not be able to change programs or channels; this is controlled by the equipment sending the signal. **If the service being used is the one which setup includes a box with two different outputs for two different (distant) rooms, then scanning channels would help you to find the signal. Be aware that the channel to be selected varies from provider to provider; meaning that, you may have to call your provider company so they could provide you the specific channel when using high definition made TV sets. Some examples of these channels are: 105, 106, 115 and 116.**



6. Fine Tuning your TV set for Home Use.

After completing Procedure 4 or Procedure 5; please follow the steps below to optimize your TV set display:

- a. Press the **MENU** key to bring up the Menu display. Use the ▲ or ▼ button to scroll to the Advanced Video option.

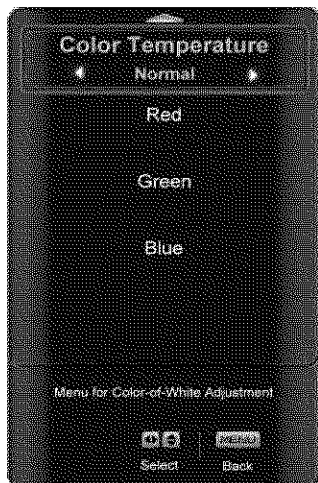

- b. Press the  button to select it.

- c. Use the ◀ or ▶ button to change setting to Normal Temperature option.

- d. Press the **MENU** key again to go back to previous screen.

- e. Press either ◀ or ▶ button to change the Picture Mode option to Standard.

- f. Press the **EXIT** key to exit the on screen display Menu.

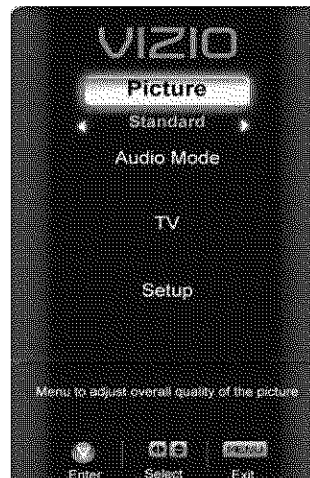

Note: If Procedure 4 had been done, you would like to do the following to ensure that the correct program times are shown when pressing the Guide key:

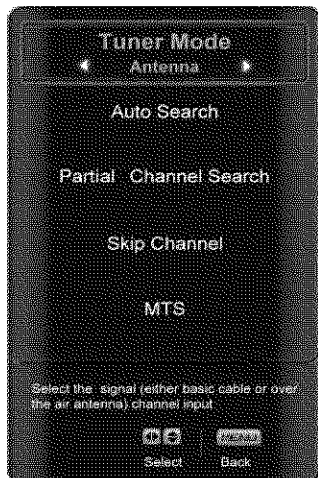

Press the **Menu** key, this will bring up the picture mode menu.

Press either ▲ or ▼ button scroll down to the next page. The next screen will appear showing Time Zone.

Press either  button to select it.

Press either ◀ or ▶ button to choose the proper Time Zone of your area.

Press the **EXIT** key once to return to your program if task has been completed.

Your new TV set is now ready to automatically reproduce the best picture quality out of the input signal which is been fed into it. Enjoy your TV watching!!



3.2 Watching a TV Program

Before you start watching TV, please make sure that any cable, satellite or off-air antenna connections are secure. Also, verify that the power cord is plugged into a correctly grounded electrical outlet or surge protector.

1. Press the power button on the remote or on the side of the HDTV. The VIZIO logo on the front will change from orange to white.
2. There are 3 options for selecting your programming:
 - a. If you are using an antenna or cable connected through the DTV/TV CABLE/ANTENNA input, you can select TV directly by pressing the TV button on the remote, or by pressing the INPUT button on the remote or on the side of the HDTV.
 - b. If you are watching broadcasts through a cable or satellite set-top box connected by an HDMI cable, select HDMI directly by pressing the HDMI button on the remote, or by pressing the INPUT button on the remote or on the side of the HDTV.
 - c. If you are watching broadcasts through a cable or satellite set-top box connected by a Component (YPbPr) cable, select Component directly by pressing the Component button on the remote, or by pressing the INPUT button on the remote or on the side of the HDTV.

Note: You should be able to see a picture. If you do not, make sure that all of the HDTV connections are secure and you have selected the correct video input source.

3. When using option 2a, press the Channel buttons on the remote or the CH+ / CH- buttons on the side of the HDTV to change the channel. Note: The Channel buttons, on the side of the HDTV and on the remote, control will not work if you are watching a program using HDMI, Component and AV inputs.



3.3 Adjusting Basic HDTV Settings

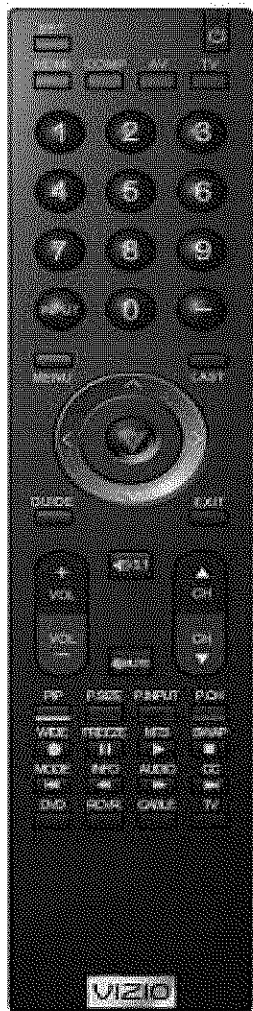

Volume

To adjust the volume, press and hold the VOL+ or VOL- button on the side of the LCD HDTV or remote control until the desired level is reached.

TV Channels

To step up or down through the available TV channels, press the CH+ or CH- button on the side of the HDTV or remote control once for the next or previous channel, or hold it depressed until the desired channel is reached. Note: Channel up and down will only operate in DTV and TV modes.

Wide

Using this feature, you can watch video content in different size modes on the HDTV.

Press the **MENU** button on the remote control to bring up the OSD screen.

Press the ▾ button and scroll down to Setup.

Press the ● button to select this option.

Press the ▾ button and scroll down to Wide.

Press either the ◀ or ▶ button to select among the modes.

For more information see Section 4.17.1 – Viewing Modes, on page 73.

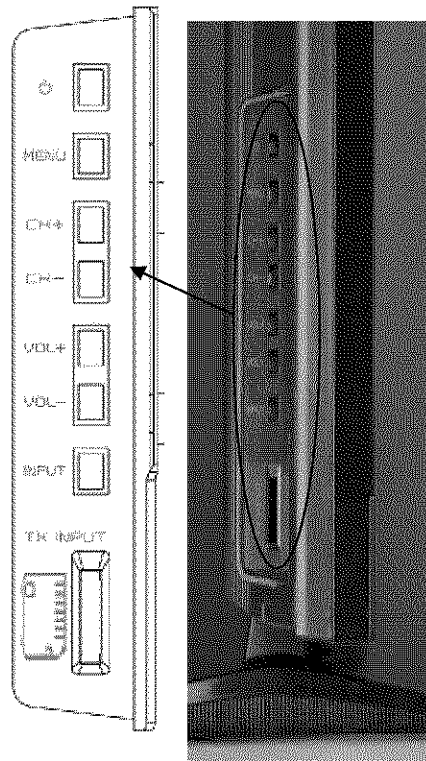

3.4 Program Information

Press the **GUIDE** button once on the remote, and the following screen will be displayed; showing the information of the channel being viewed:

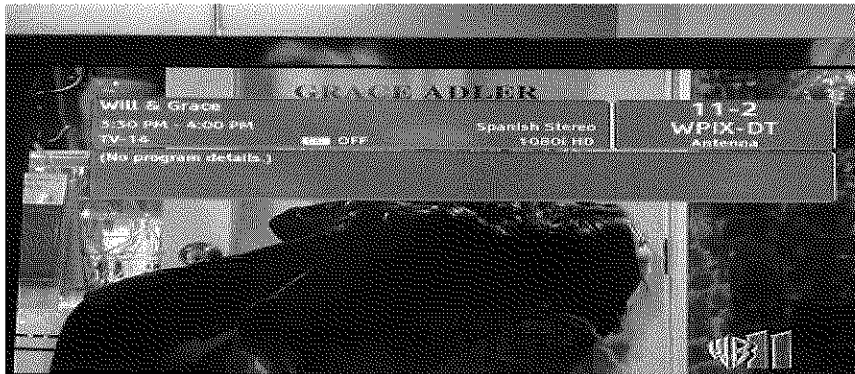

The following is an explanation of the different sections of the above banner:

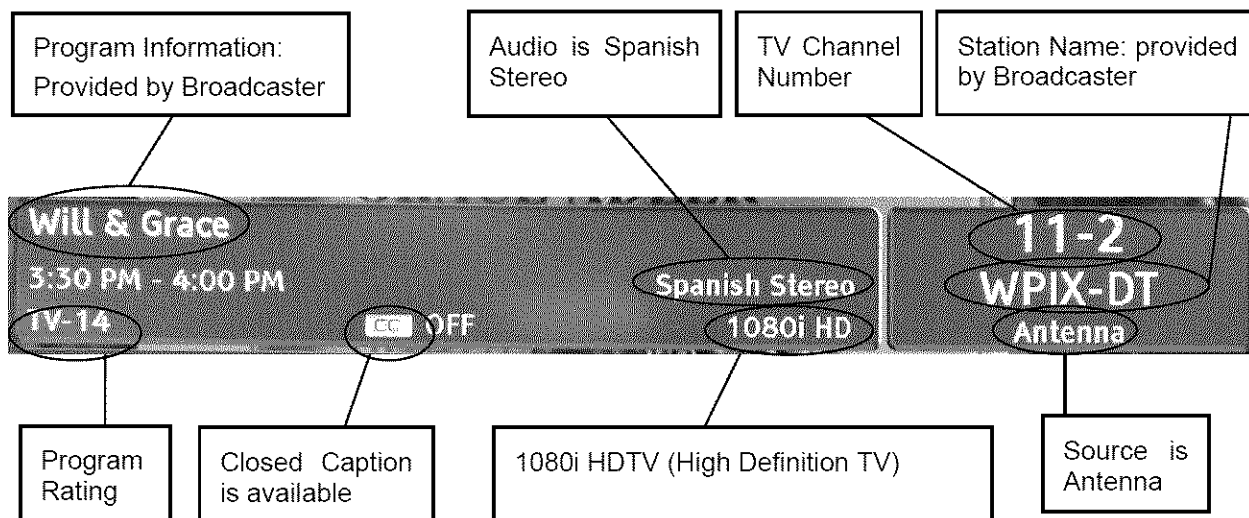

Press the **GUIDE** button twice and at least two and half hours of programming will be shown on the display; as shown below:

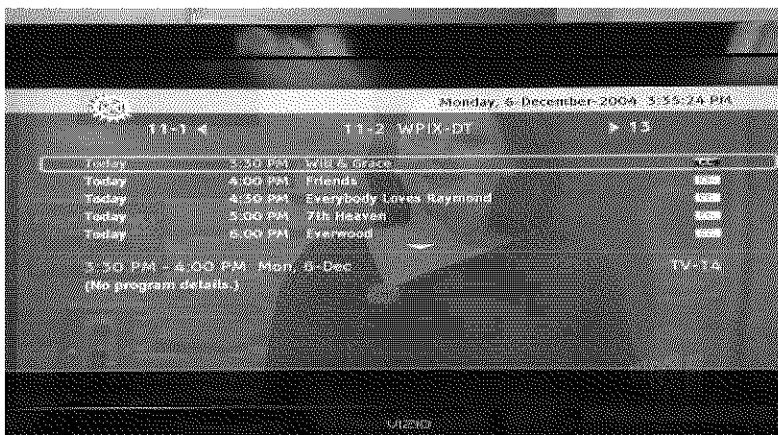

Chapter 4 Advanced Adjustment of HDTV

4.1 Using the On Screen Display (OSD)

The remote control or the control buttons on the right hand side of the TV can control all the function settings. The On Screen Display (OSD) allows you to adjust the save contrast, brightness and other settings. The TV will save changes made to the settings, even if the TV is turned off.

The OSD consists of several menu options: Picture Adjust, Audio Adjust, Setup and TV Tuner Setup. The main menu options may vary depending on your selected input source.

Note: Some of the main menu options may have additional submenus, i.e. the TV Rating submenu for Parental Controls.

Press the **MENU** button on the remote control or the side of the TV and the Picture menu will be shown on the screen.

Press the \blacktriangledown or \blacktriangle button on the remote control or the **CH +** or **CH -** button on the side of the HDTV to select one of the other menu options:

Picture (Picture Adjust)

Audio Mode (Audio Adjust)

TV (TV Tuner Setup)

Setup (Global Settings)

Press  to select the option or feature which you want to adjust.

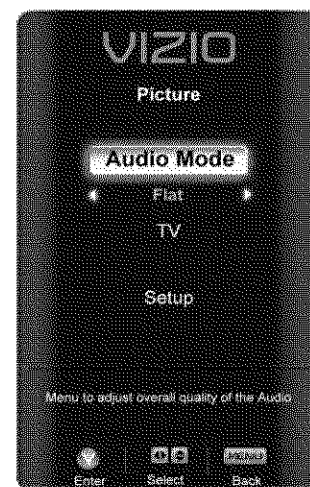

Once the menu option is displayed, press the \blacktriangleleft or \blacktriangleright button on the remote control or the **VOL +** or **VOL -** button on the side of the TV to adjust the desired option.

Press the **MENU** key once to return to the previous screen or press the **EXIT** to return to your program if task has been completed.



4.2 DTV / TV Input Picture Adjustment

4.2.1 Picture Mode

When the **MENU** button is pressed, the On Screen Display (OSD) appears on the PICTURE adjustment page.

Press the  button to select the Picture Mode selection.

Use the ◀ or ▶ button to choose from Custom, Standard, Movie, Game, Vivid, Football, Golf, Basketball and Baseball.

Picture Adjustments are available for you to set them to your preferred settings.

Once the adjustments are completed press the **EXIT** button to exit the OSD completely.



4.2.2 Backlight

Press the ▼ button to highlight the Backlight selection.

Use the ◀ or ▶ button to adjust the level.

The Backlight level does not affect the Brightness (black level) or Contrast (white level) of the picture, it adjusts the lamp current and this affects the overall brilliance of the picture.

Once the adjustments are completed press the **EXIT** button to exit the OSD completely.

Note: This setting will be disabled and disappear if Enhanced Contrast Ratio is turned on.

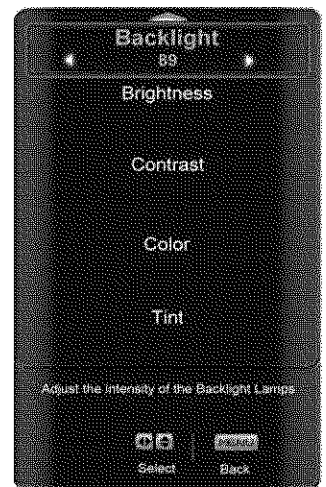

4.2.3 Brightness

Press the ▼ button to highlight the Brightness selection.

Use the ◀ or ▶ button to adjust the level.

The Brightness adjusts the black levels in the picture. If the brightness is too low you will not be able to see the detail in darker parts of the picture and if the brightness is too high the picture will look washed out.

Once the adjustments are completed press the **EXIT** button to exit the OSD completely.

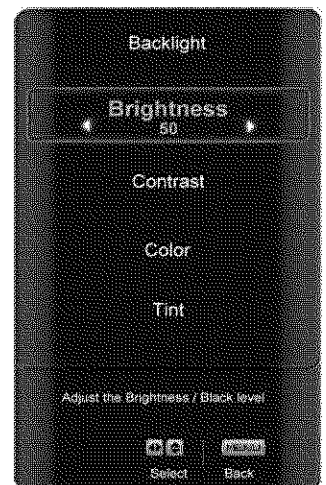

4.2.4 Contrast

Press the **▼** button to highlight the Contrast selection.

Use the **◀** or **▶** button to adjust the level.

The Contrast adjusts the white levels in the picture. If the contrast is too low the picture will look washed out and if the contrast is too high you will not be able to see any detail in the bright parts of a picture.

Once the adjustments are completed press the **EXIT** button to exit the OSD completely.

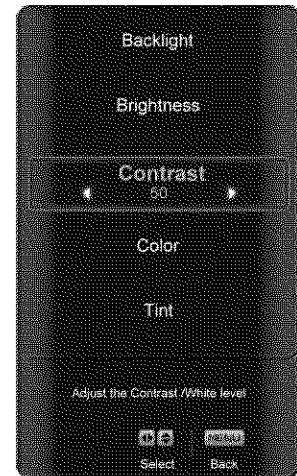

4.2.5 Color

Press the **▼** button to highlight the Color selection.

Use the **◀** or **▶** button to adjust the level.

The Color adjusts the amount of color in the picture.

Once the adjustments are completed press the **EXIT** button to exit the OSD completely.

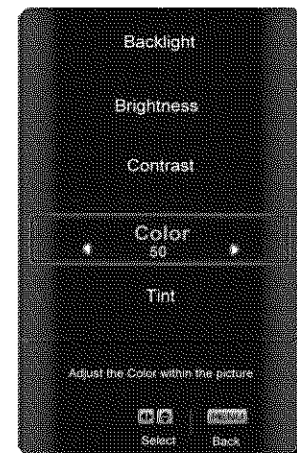

4.2.6 Tint

Press the **▼** button to highlight the Tint selection.

Use the **◀** or **▶** button to adjust the level.

The Tint adjusts the hue of the picture. The easiest way to set tint is to look at flesh tones and adjust for a realistic appearance. In most cases, the default middle position is correct. If people's faces look too orange try reducing the level of color first as the case of this is often too much color.

Once the adjustments are completed press the **EXIT** button to exit the OSD completely.

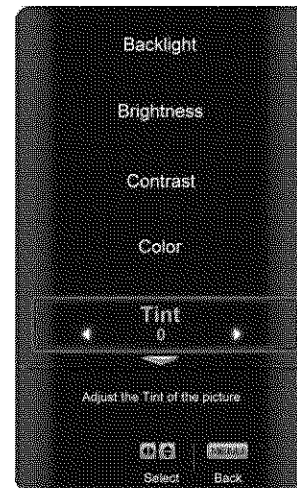

4.2.7 Sharpness

Press the ▼ button to highlight the Sharpness selection.

Use the ◀ or ▶ button to adjust the level.

The Sharpness adjusts the sharpness of the picture.

Once the adjustments are completed press the **EXIT** button to exit the OSD completely.

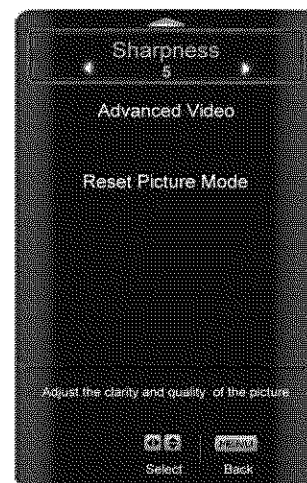

4.2.8 Advanced Video Features

Press the ▼ button to highlight the option for Advanced Video selection. Press either the  button to select it. A new menu will be displayed showing the advanced functions available for fine tuning of the picture.

Noise Reduction (SNR)

Press the ▼ button to highlight Smart Noise Reduction (SNR). Use this feature to diminish picture artifacts caused by the digitizing of image motion content that may be present in the picture.

Press the ◀ or ▶ button to choose from the Off, Low, Medium or Strong setting.

Once the adjustments are completed press the **EXIT** button to exit the OSD completely.

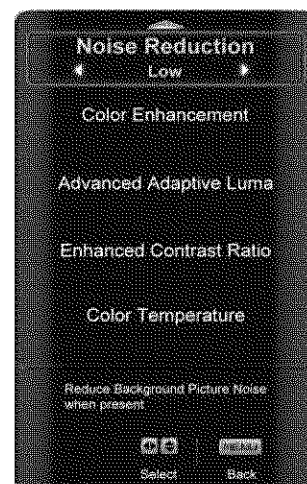

Color Enhancement

Press the ▼ button to highlight Smart Color Enhancement. Use this feature to increase the picture reproduction performance of the picture.

Press the ◀ or ▶ button to choose from Off, Normal, Rich Color, Green/Flesh and Green/Blue setting.

Once the adjustments are completed press the **EXIT** button to exit the OSD completely.



Advanced Adaptive Luma

Press the \blacktriangledown button to highlight Advanced Adaptive Luma. Large areas of darkness in a picture will result in a lower Average Picture Level (APL) and the overall picture will look too dark; activation of this feature will raise the APL to counteract this effect.

Press the \blacktriangleleft or \blacktriangleright button to choose from the Off, Low, Medium, Strong or Extend setting.

Once the adjustments are completed press the **EXIT** button to exit the OSD completely.

Enhanced Contrast Ratio (DCR)

Press the \blacktriangledown button to highlight Enhanced Contrast Ratio. This feature can be set to On or OFF to allow the TV set to adjust its backlight to display dark and bright scenes with a more vivid or intense quality.

Press the \blacktriangleleft or \blacktriangleright button to turn this feature On or Off. Note: Backlight setting would be disabled if this option is set to On.

Once the adjustments are completed press the **EXIT** button to exit the OSD completely.



Color Temperature

Press the \blacktriangledown button to highlight the option for Color Temperature selection.

The default is COOL; this is the 9300K setting.

Press the \blacktriangleleft or \blacktriangleright button if you want to choose the Normal, Warm or Custom option.

If you select any option, then a new menu will be displayed showing the primary colors; Red, Green and Blue.

Press the \blacktriangledown button to highlight the color you wish to adjust.

Press the \blacktriangleleft or \blacktriangleright button to start adjusting the color.

Use the \blacktriangleleft or \blacktriangleright button to adjust the color.

Press the **MENU** button when finished. Repeat the procedure to adjust the other colors if desired.

Once the adjustments are completed press the **EXIT** button to exit the OSD completely.

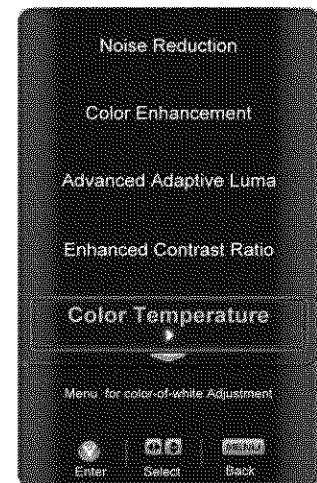

Smooth Motion Effect

The Smooth Motion option is a switch option which controls the intensity or levels of intensity of the video (Smooth and Precision) features incorporated in this TV model.

Press the \blacktriangledown button to highlight the Smooth Motion option.

Use the \blacktriangleleft or \blacktriangleright button to select your choice. There are four choices; Off, Low, Middle or High, please select your preference.

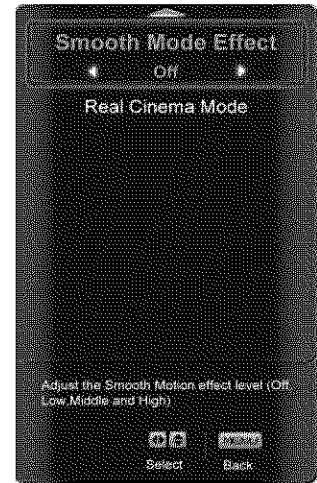

Real Cinema Mode

The use of this option will allow you to select the two new features built-in in this model. These features are described as operational (features) functions designed to enhance the quality of the images or programming being viewed.

Press the \blacktriangledown button to highlight the Real Cinema Mode option.

Use the \blacktriangleleft or \blacktriangleright button to select your choice. There are three choices; Off, Precision and Smooth.

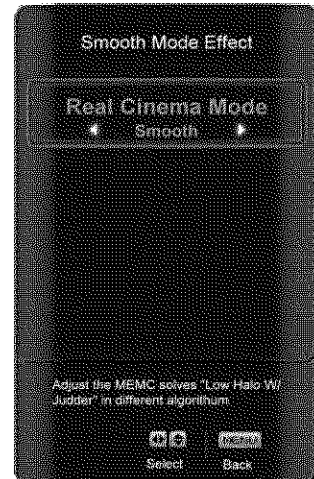

Precision Feature

When selecting this feature you will obtain a sharper image of the scene you are watching; sometimes depending on the quality of the signal and quality of the recorded pictures (movies), the presence of the halo effect will not be noticeable.

Smooth Feature

This feature will allow increasing the quality of the picture as far as to motion on the scenes it refers, eliminating the effect of juddering during a fast action moving scene and sports programs. Depending on the quality of the signal being watched, the halo effect is noticeable.

Once the adjustments are completed press the **EXIT** button to exit the OSD completely.

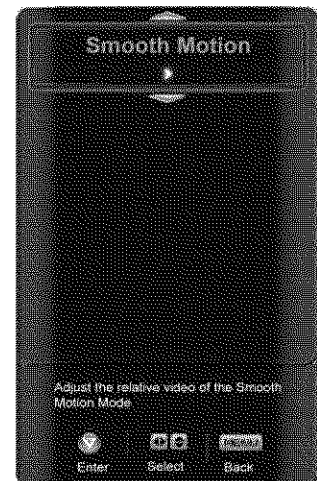

4.2.g Reset Picture Mode

Press the ▼ button to highlight the option for Reset Picture Mode selection

Press ► button to return the Picture settings to factory default.

A screen will come up to give you the options of either to confirm your selection or to cancel it, if you had changed your mind

Press either ◀ or ▶ to make the selection.

Press  to accept it.

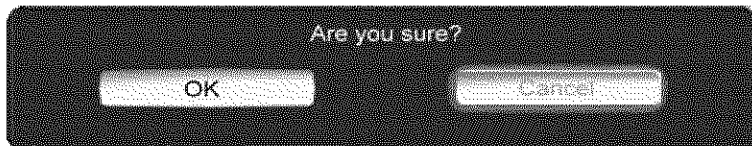
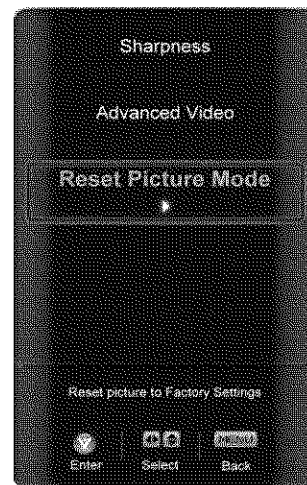

Once the adjustments are completed press the **EXIT** button to exit the OSD completely.

Note: Only settings under the Picture adjustments will be reset.



4.3 DTV / TV Audio Adjustment

4.3.1 Audio Mode

When the **MENU** button is pressed, the On Screen Display (OSD) appears on the PICTURE adjustment page.

Press the ► button to display the AUDIO ADJUST page.

Press the ▼ button to highlight the Audio Mode selection.

Use the ◀ or ▶ button to choose from Flat, Rock, Pop, Classic or Jazz.

Equalizer adjustments are available for you to set them to your preferred settings.

Once the adjustments are completed press the **EXIT** button to exit the OSD completely.

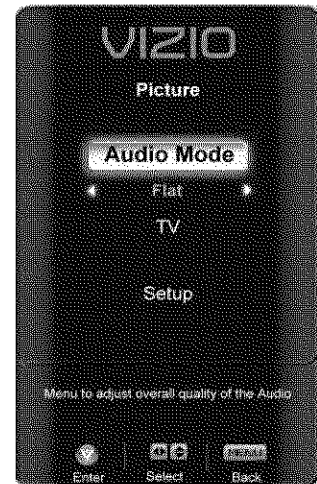

4.3.2 Equalizer

Press the ▼ button to highlight the Equalizer selection.

A new menu will be displayed showing volumes of different frequencies (pitches).

Use the ◀ or ▶ button to select the frequency to be adjusted.

Starting from lowest to the highest pitch, they are 120 Hz, 500Hz, 1.5 kHz, 5kHz and 10kHz.

Press the ▼ or ▲ button to adjust the selected frequency to your preference. For example if you want to boost the bass you would highlight 120Hz and turn it up.

Once the adjustments are completed press the **EXIT** button to exit the OSD completely.

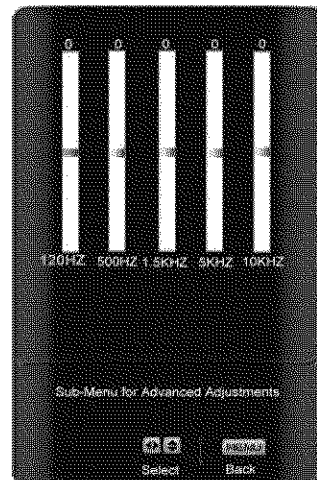

Note: The equalizer option is not available in the SRS TSXT surround effect mode.

4.3.3 Balance

Press the ▼ button to highlight the Balance selection.

Use the ◀ or ▶ button to adjust the left/right balance.

Once the adjustments are completed press the **EXIT** button to exit the OSD completely.



4.3.4 Digital Audio Out

This feature uses the SPDIF (Optical connector) audio signal to be used through Home Theatre system.

Press the \blacktriangledown button to highlight the Digital Audio Out selection.

Press the \blacktriangleleft or \blacktriangleright button to make the proper selection. The options are OFF, Dolby Digital and PCM.

Once the adjustments are completed press the **EXIT** button to exit the OSD completely.

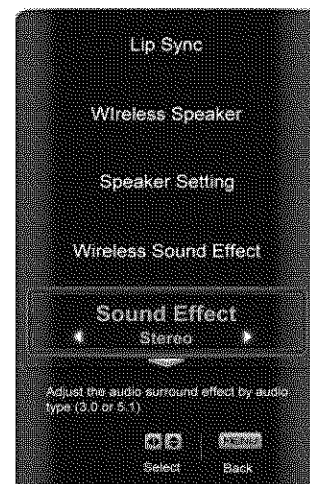

4.3.5 Speakers

Press the \blacktriangledown button to highlight the Speakers selection.

Press either \blacktriangleleft or \blacktriangleright button to turn the internal speakers On or Off. You may want to turn-off the internal speakers when listening to the audio through your Home Theatre System.

Once the adjustments are completed press the **EXIT** button to exit the OSD completely.

4.3.6 Analog Audio Out

When using the RCA (white and red) connectors as audio line out to connect a stereo system.

Press the \blacktriangledown button to highlight the Analog Audio Out selection.

Press either \blacktriangleleft or \blacktriangleright button to turn the audio out signal to Fixed or Variable. When it is set to variable, volume from the external speakers will change according to the volume setting on the TV. If it is fixed, the volume can only be changed by the settings on the external stereo system.

Once the adjustments are completed press the **EXIT** button to exit the OSD completely.

4.3.7 Lip Sync

Included with the advanced technology of your TV, a feature which will compensate the shortcomings of signal transmission called audio sync (Lip Sync). Lip Sync is designed to adjust the audio of the program being viewed so that it matches the movement of the lips of someone talking on the screen. This feature is built into your set, and it can be applied to all inputs. To use this feature, follow the steps below.

Press the **MENU** key to bring up the OSD.

Press either \blacktriangledown or \blacktriangleup button to scroll either up or down to Lip Sync.

Press either \blacktriangleleft or \blacktriangleright button to make the appropriated adjustment.

Press either the **MENU** key once to return to the previous screen or the **EXIT** key to return to your program if task has been completed.

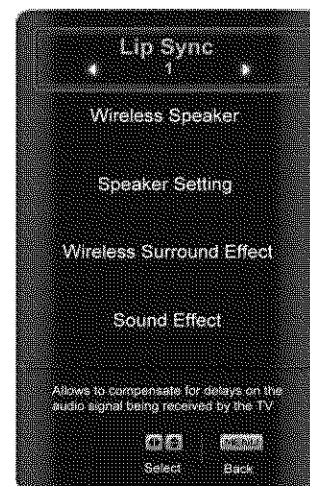

Added Audio (Sound) Features

Even though; the SV470XVT1A comes equipped with SRS (TruSurroundXT) digital audio, your TV has a built-in enhancement feature called Wireless Speaker which allows you to upgrade the audio to Dolby Digital 5.1 surround sound; through the purchasing of our Wireless Speakers System.

4.3.8 Wireless Speaker

Press either \blacktriangledown or \blacktriangle button to scroll either up or down to Wireless Speaker.

Press either \blacktriangleleft or \blacktriangleright button to select it either On or Off.

If you select ON and the following message appears; that implies that the TV has not been upgraded with the Wireless Speaker System. By not having the upgrade, all the features or options which apply to the Dolby Digital 5.1 surround sound are not available

**NO WIRELESS SPEAKER DETECTED
PLEASE REFER TO USER MANUAL.**

If you had obtained the upgrade (Wireless Speaker System) kit, and still the above message is displayed please refer to the instructions which come with the upgrade kit to verify that you had done the correct steps to match up or pair up the Wireless set and the TV.

4.3.9 Speaker Setting

This option allows having a better or handing control of the Wireless System.

Press the \blacktriangledown button to highlight the Speaker Setting selection.

Press  to accept it. The following options and adjustments will become available to you to set the TV sound to your desired preferences.

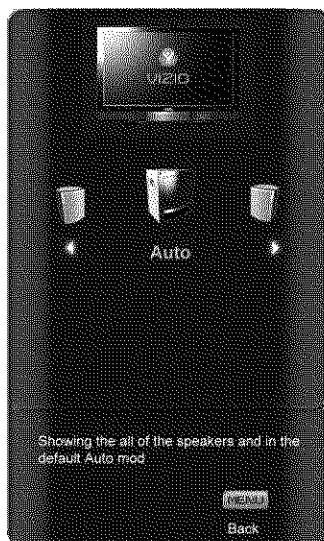

Speakers Location

When selecting this option, the TV will reproduce a sound which will indicate the location of the different speakers as well and their proper operation. It means that while the screen will show the an icon of the speaker being test, the sound will let you know not only if the speaker is properly functioning, but also will let you know if it is in the right position (Left, Center, Right, Left Rear, Subwoofer and Right Rear) maximizing the sound quality of the surround sound and the reproduction of the special effects (i.e; airplanes traveling direction, explosions,, etc) of a movie.

Press the \blacktriangledown button to highlight the Speaker Location option.

Press \blacktriangleright button to run this option.

Press either the **MENU** key to stop the cycling of this option and go back to previous menu display or the **EXIT** key to exit the OSD completely.



Speakers Distance

The range of the wireless system is up to 35 feet for the subwoofer and each satellite speaker (Rear Left and Rear Right) comes with a 15 feet of speaker wire. Adjusting this option will allow you to take advantage of setting the TV to the specific distances within the constraints of your room. The distance between subwoofer and TV is set in increments of 5 feet up to 35 feet, and the values applicable to the satellites are in increments of 3 feet up to 15 feet. These values are used to adjust the response needed for the audio signal to reach the Subwoofer and satellite speaker without loss of quality output by the speakers.

Press the \blacktriangledown button to highlight the Speaker Distance option.

Press  to choose the speaker which value needs to be adjusted.

Press  or  to set the value.

Press either the **MENU** key to go to the previous menu to adjust a second speaker or the **EXIT** key to exit the OSD completely.

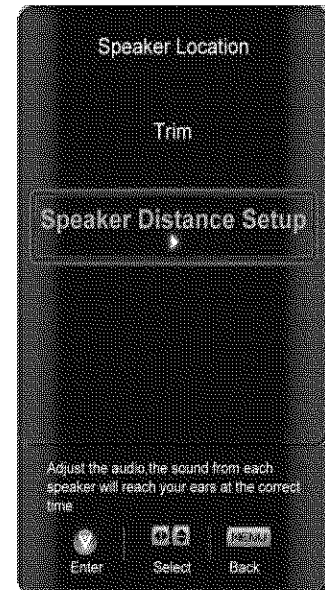

Trim

This allows the adjustments of each individual speaker volume according to your preferences.

Press the \blacktriangledown button to highlight the Trim option.

Press the \blacktriangleright button to select it.

Press either the \blacktriangle or \blacktriangledown button to select the speaker which value needs to be adjusted.

Press either \blacktriangleleft or \blacktriangleright to make the desired adjustment.

Press either the \blacktriangle or \blacktriangledown button again to select the next speaker.

Press either \blacktriangleleft or \blacktriangleright to make the desired adjustment.

You can repeat these two steps to set the values for all six (Left, Right, Rear Left, Rear Right, Center and Subwoofer) speakers, or press the **MENU** key to go to previous menu or press **EXIT** key to exit the OSD completely.

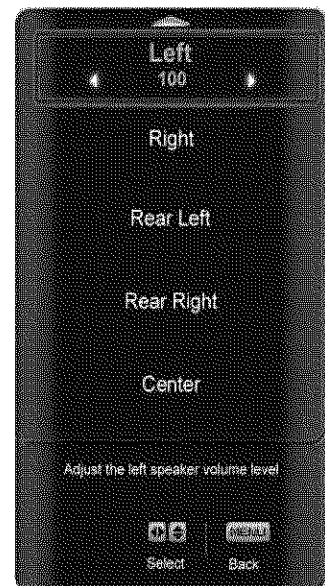

4.3.10 Wireless Sound Effect

This feature allows making a selection of the output sound reproduce by the wireless speaker system, depending on the type of the audio signal being supplied.

Press the ▼ button to highlight this option.

Press either ◀ or ▶ to select (Dolby Digital Prologic II Music, Dolby Digital Prologic II Movie or Dolby Digital Prologic II Matrix) the kind of sound you want to match with the audio signal being supplied to the TV.

If Wireless speaker has been selected Off, then you can continue with the next option of the menu.



Note: When a program carrying a Dolby Digital 5.1 signal; is supplied to the TV, a LED (red 5.1) indicator displaying such signal can be seen on the bottom right hand side of the center speaker.

4.3.11 Sound Effect

As it was previously mentioned your TV comes with a factory setting of SRS (TruSurroundXT) digital audio selection which is the perfect option when using the TV as stand alone unit, but we at VIZIO gives you the options to select the audio output to your own preferences.

Press the ▼ button to highlight this option.

Press either ◀ or ▶ to go through the different (Regular Stereo, Stereo + Center Speaker and SRS TSXT) adjustments and select the one to your preference.



4.3.12 DRC (Dynamic Range Compression)

This option allows adjusting the dynamic range compression of the audio encoded in a Dolby Prologic II signal input into the TV.

Press the \blacktriangledown button to highlight the DRC option.

Press either \blacktriangleleft or \blacktriangleright to select the desired setting. The values are either Full, $\frac{1}{4}$, $\frac{1}{2}$, $\frac{3}{4}$ and Off.

Once the adjustments are completed press the **EXIT** button to exit the OSD completely.

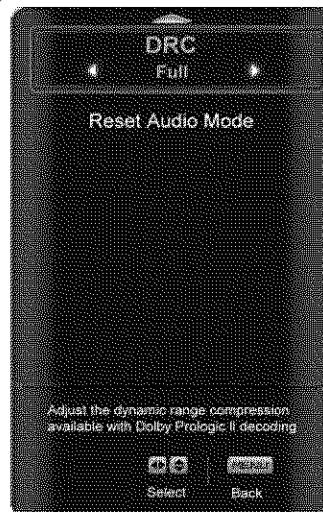

4.3.13 Reset Audio Mode

Press the \blacktriangledown button to highlight the option for Reset Audio Mode selection

Press \blacktriangleright button to return the Audio settings to factory default.

The options of either accepting or cancelling the resetting will be display.

Press either \blacktriangleleft or \blacktriangleright to make the selection.

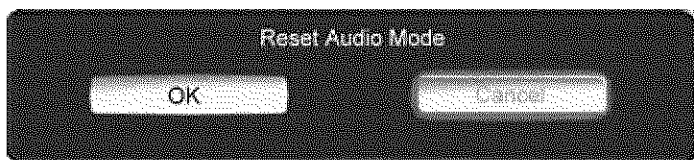
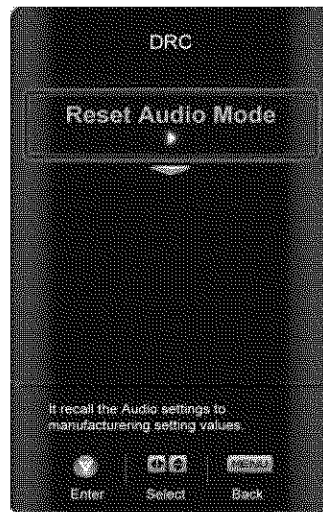

Press  to accept it.

Note: Only settings under the Audio adjustments will be reset.

Once the adjustments are completed press the **EXIT** button to exit the OSD completely.



4.4 DTV / TV Tuner Setup

When you first used your HDTV you will have setup your TV for DTV / TV channels using the Initial Setup screens. If you did not do this or if your setup has changed, you can do this from the TV TUNER SETUP menu.

Once the adjustments are completed press the **EXIT** button to exit the OSD completely.

4.4.1 Tuner Mode

When the **MENU** button is pressed, the On Screen Display (OSD) appears on the PICTURE adjustment page. Press the **▶** button to display the TV page.

Press the **▼** button to highlight the Tuner Mode selection.

Press the **▶** button to choose Cable or Air (Antenna) depending upon which equipment you have attached to the DTV / TV Input.

Once the adjustments are completed press the **EXIT** button to exit the OSD completely.



4.4.2 Auto Search

Press the **▼** button to highlight the Auto Search selection.

Press the **▶** button to Auto Search for TV channels available. The TV will automatically search for analog and digital channels.

Once the adjustments are completed press the **EXIT** button to exit the OSD completely.

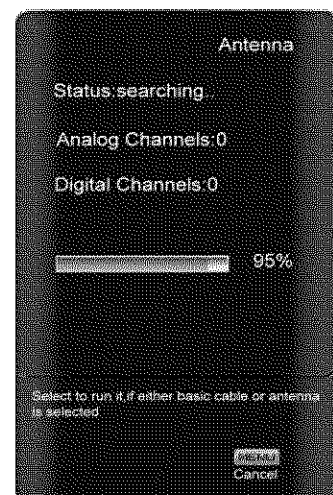

4.4.3 Partial Channel Search

If you believe channels are missed from the auto search, you can do a partial channel search to look for channel in a certain channel range again.

Press the \blacktriangledown button to highlight the Partial Channel Search selection.

Press the \blacktriangleright button to enter the submenu.

Press the \blacktriangleright button to select scan mode to look for Analog, Digital, or both Analog/Digital channels.

Press the \blacktriangledown button to highlight the "To" and "From" selection. Press the \blacktriangleright button to select the range of channel numbers you want to start searching in.

Press  to start channel search.

Once the adjustments are completed press the **EXIT** button repeatedly to exit the OSD completely.

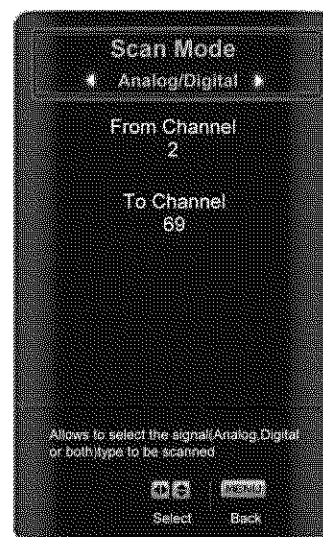

4.4.4 Skip Channel

After the TV has stored all of the available DTV channels in memory you will find that some channels will be too weak to watch comfortably or they may be channels you do not want to see. Select the channel you wish to remove by pressing the **MENU** button to bring up the OSD.

Press the \blacktriangleright buttons to open the TV TUNER SETUP menu.

Press the \blacktriangledown button to highlight SKIP CHANNEL.

Press the \blacktriangleright button to select this channel to be skipped when using the CH+ or CH- button. You will still be able to select this channel using the number buttons on the remote control.

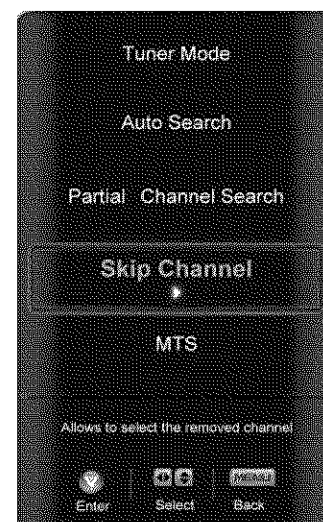

4.4.5 MTS

This feature allows you, the user to select the different languages in which the signal provider or broadcaster is transmitting the audio with the program you are watching. This signal is usually or in most cases Spanish language.

Press the \blacktriangledown button as many times as it takes to scroll down to this option and get it highlighted.

Press either \blacktriangleleft or \blacktriangleright button to go through the settings of this feature to make your selection.

Once the adjustments are completed press the **EXIT** button to exit the OSD completely.

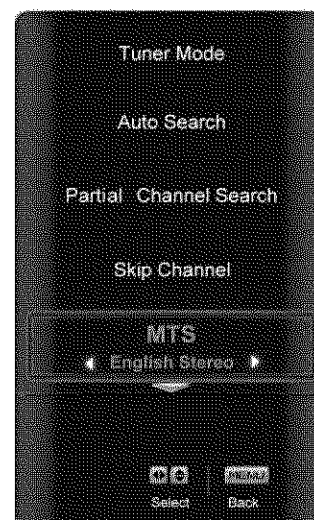

4.4.6 Time Zone

Setting the correct Time Zone for your area will ensure that the correct program times are shown after pressing the GUIDE button on the remote control.

Press the ▼ button to highlight the Time Zone selection.

Press the ► button to select your area.

Once the adjustments are completed press the **EXIT** button to exit the OSD completely.

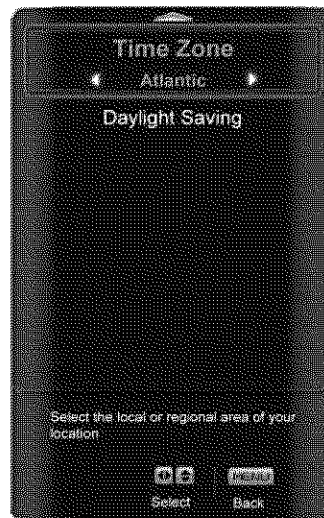

4.4.7 Daylight Saving

As for Time Zone, setting the daylight saving time for your area will ensure that the correct program times are shown after pressing the GUIDE button on the remote control.

Press the ▼ button to highlight the Daylight Saving selection.

Press the ► button to select On or Off.

Once the adjustments are completed press the **EXIT** button to exit the OSD completely.

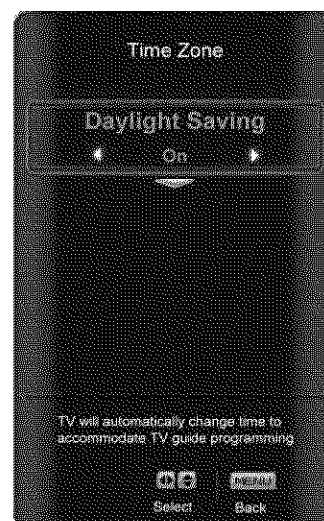

4.5 DTV / TV Input Setup

4.5.1 Language

When the **MENU** button is pressed, the On Screen Display (OSD) appears on the PICTURE adjustment page. Press the **▶** button until the SETUP page is displayed.

Press the **▼** button to highlight the Language selection. The default is English.

Press the **▶** button to select Español or Français.

Once the adjustments are completed press the **EXIT** button to exit the OSD completely.

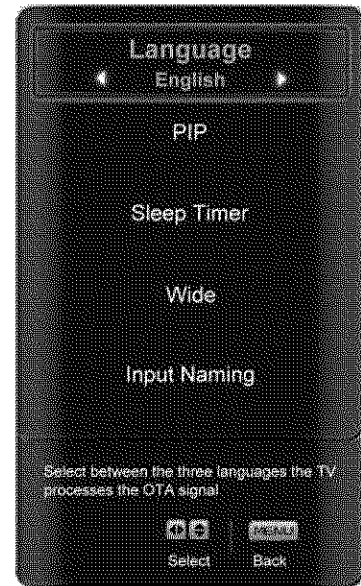

4.5.2 PIP (Picture-in-Picture)

Press the **▼** button to highlight the PIP (Picture-in-Picture) selection.

Press the **▶** button. A separate menu will appear with the following PIP settings.

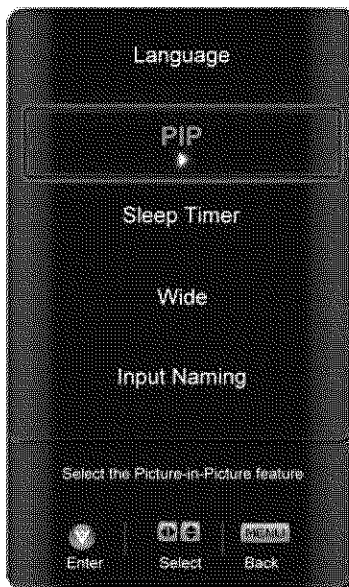

PIP Mode

Press the **▼** button to highlight the PIP mode selection.

Press the **◀** or **▶** button to select Off, PIP or POP (Picture-outside picture). In the PIP mode a smaller sub screen will be displayed on top of the main screen. For the POP mode the main screen and sub screen will be of equal size and be positioned side by side.

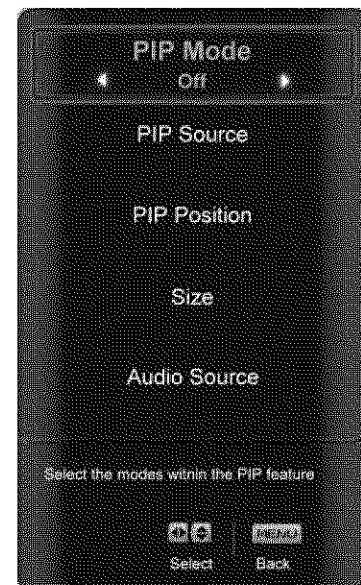

PIP Source

When PIP or POP is selected, Press the ▾ button to highlight the PIP input selection.

Press the ◀ or ▶ button to choose the input source for the sub screen. The input sources available will vary according to which input is used for the main screen; see the table below to find which inputs can PIP/POP with each other.

See below for detailed information regarding the PIP sources.

MAIN \ SUB	DTV	TV	AV1	AV2	Component 1	Component 2	HDMI1	HDMI2	HDMI3	HDMI4	RGB
DTV					✓	✓	✓	✓	✓	✓	✓
TV					✓	✓	✓	✓	✓	✓	✓
AV1					✓	✓	✓	✓	✓	✓	✓
AV2					✓	✓	✓	✓	✓	✓	✓
Component 1	✓	✓	✓	✓			✓	✓	✓	✓	
Component 2	✓	✓	✓	✓			✓	✓	✓	✓	
HDMI 1	✓	✓	✓	✓	✓	✓					✓
HDMI 2	✓	✓	✓	✓	✓	✓					✓
HDMI 3	✓	✓	✓	✓	✓	✓					✓
HDMI 4	✓	✓	✓	✓	✓	✓					✓
RGB	✓	✓	✓	✓			✓	✓	✓	✓	

“✓” – Indicates which inputs are available for PIP and POP modes.

PIP Position

When PIP is selected, Press the ▾ button to highlight the PIP position selection.

Press the ◀ or ▶ button to choose where on the picture you want the PIP screen positioned over the main screen.

PIP Size

When PIP is selected, Press the ▾ button to highlight the PIP size selection.

Press the ◀ or ▶ button to choose Small, Medium or Large.

PIP Audio Source

When PIP or POP is selected, Press the ▾ button to highlight the PIP audio source selection.

Press the ◀ or ▶ button to choose the audio source from the main screen or the sub screen.

Once the adjustments are completed press the **EXIT** button to exit the OSD completely.



4.5.3 Sleep Timer

Press the **▼** button to highlight the Sleep Timer selection.

Press the **▶** button to select the timer to turn-off the TV in 30, 60, 90 or 120 minutes.

Once the adjustments are completed press the **EXIT** button to exit the OSD completely.

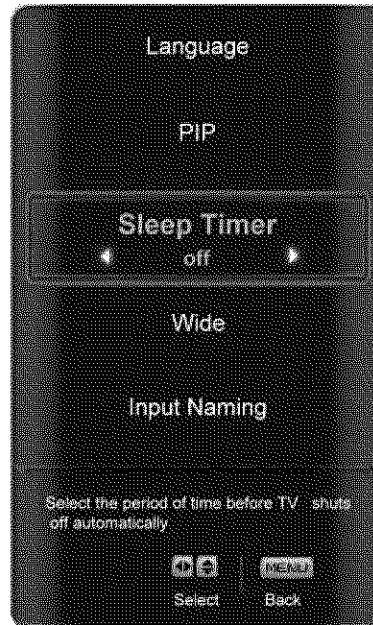

4.5.4 Wide

The Wide option is the feature which allows you to select how your display would be size wise. When in TV mode; the selections are Normal, Wide, Panoramic and Zoom views.

Press the **▼** button as many times as it takes to scroll down to this option and highlight it.

Press either **◀** or **▶** button to make the correct selection; you will see the screen adjusting to the different sizes which apply to this feature.

Once the adjustments are completed press the **EXIT** button to exit the OSD completely.

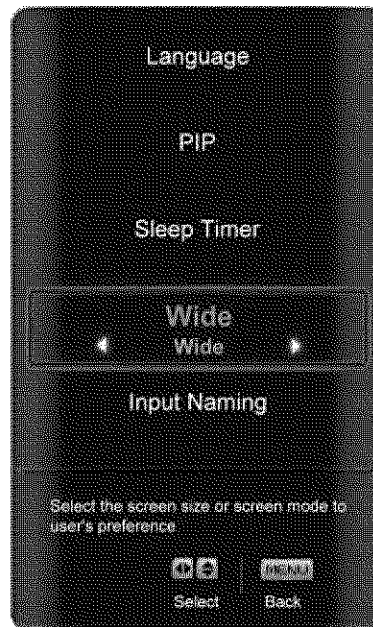

4.5.5 Input Naming

This feature has been added to facilitate you, the user in identifying or label the input and signal which is being watched. You could use up to 8 characters; either letters or numbers or combinations of both.

Press **▼** button to highlight this option.

Press **▶** button to obtain the next screen which shows the different inputs.

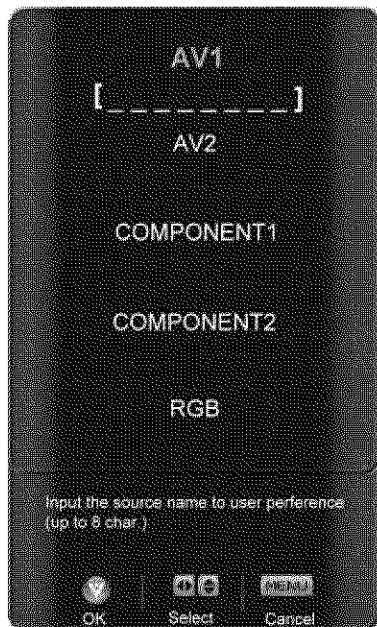

Press **▼** button to select the desired input which you want to label or name (Examples: VCR, DVD,..., etc.) it with any name which will make easier for you to recognize it.

Press the **○** key to go to the first space () in the bracket.

Press either the **▲** or **▼** button and select either the letter or number belongs to this place.

Press the **▶** button to go to the next space () and again

Using either the **▲** or **▼** button select the second character of the name given to this Input.

Repeat the last previous two steps until the name of the input is completed.

Press the **○** key to accept the name of the input or the **EXIT** key to cancel the setting. .

Press the **MENU** key when you have finished to go to the previous menu.

Since you are already in this feature; it is recommendable to name all the Inputs which are being used as well as these for which you have an idea what their name is going to be.

Once the adjustments are completed press the **EXIT** button to exit the OSD completely.

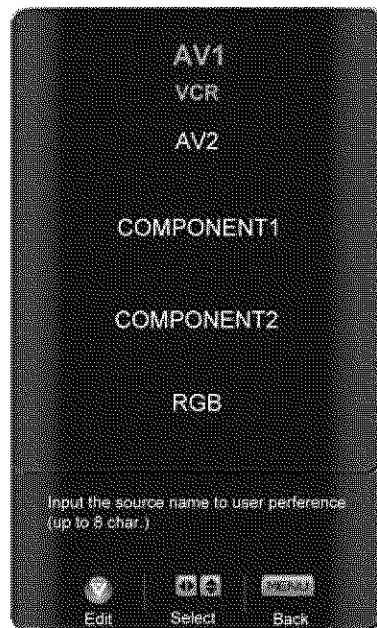
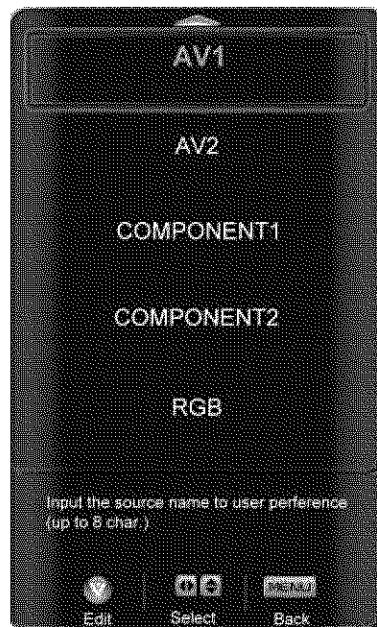

4.5.6 CC (Closed Caption)

Press the **▼** button to highlight the CC (Closed Caption) selection.

Press the **▶** button. A separate menu will appear with the following CC settings

CC

When watching regular analog (NTSC) TV, the CC feature is available in the Setup menu.

Press the **▼** button to highlight the CC selection.

Press the **▶** button to select CC1, CC2, CC3 or CC4.

Once the adjustments are completed press the **EXIT** button to exit the OSD completely.

Closed Caption for regular TV is usually CC1 or CC2.

Digital Closed Caption Style

When watching DTV, the Digital CC Style feature is available in the Setup menu.

Press the **▼** button to highlight the Digital CC Style selection.

Press the **▶** button to go to the next screen.

Press either **◀** or **▶** button to toggle between the two options; As Broadcaster and Custom.

If Custom is selected then you will have the way of customize the way Closed Caption will be displayed by changing these different parameters to your like: **Font Size** (letters size), **Font Color** (letters color) **Font Opacity** (transparency of the letters), **Background Color** (color of the background area where Closed Caption is going to be displayed), **Background Opacity** (allows to either see through at the scene being played or it could be a solid screen), **Window Color** (it gives the color to the area where characters will be displayed on) and finally **Window Opacity** (allows the area of the characters to be changed). There are no recommendations of setting these parameters since you, the user would have your own taste or like of them.

Once the adjustments are completed press the **EXIT** button to exit the OSD completely.

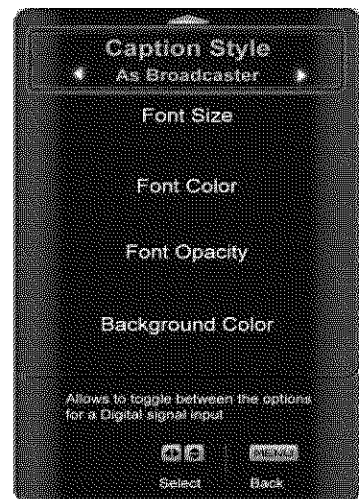
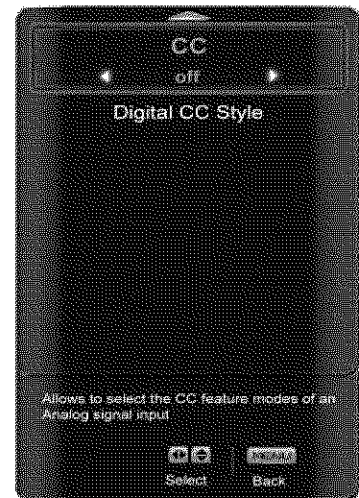
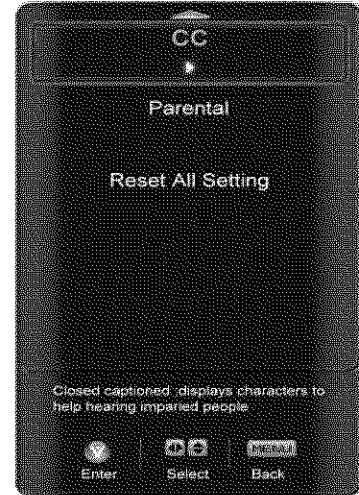

4.5.7 H/V Position

Press the ▼ button to highlight the H/V Position selection.

Press the ► button. A separate menu will appear with the following H/V Position settings

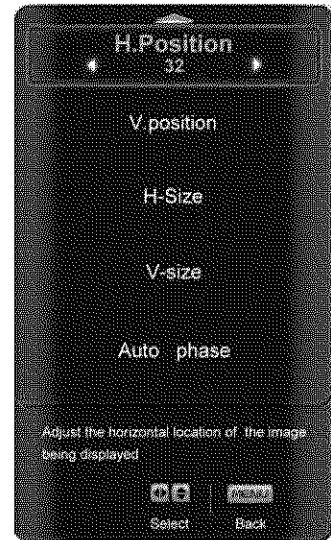

H - Position

Press the ▼ button to highlight the Horizontal Shift selection.

Use the ◀ or ▶ button to adjust the horizontal position.

Once the adjustments are completed press the **EXIT** button to exit the OSD completely.

V - Position

Press the ▼ button to highlight the Vertical Shift selection.

Use the ◀ or ▶ button to adjust the vertical position.

Once the adjustments are completed press the **EXIT** button to exit the OSD completely.

H - SIZE

Press the ▼ button to highlight the H-Size selection.

Use the ◀ or ▶ button to adjust the horizontal size.

Once the adjustments are completed press the **EXIT** button to exit the OSD completely.

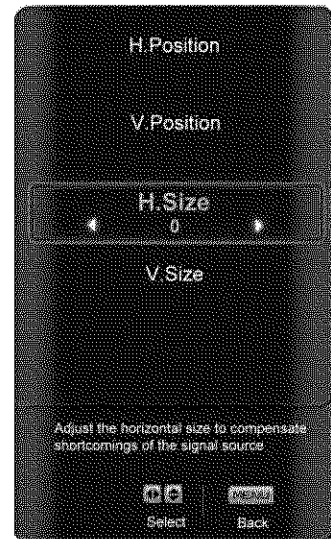

V - SIZE

Press the ▼ button to highlight the V-Size selection.

Use the ◀ or ▶ button to adjust the vertical size.

Once the adjustments are completed press the **EXIT** button to exit the OSD completely.



4.5.8 DTV / TV Input Parental Control

If you want to restrict certain channel and program viewing, you can do this by turning on the Parental Control. Selected programs, movies and channels can then be made available only after an authorized password has been entered and accepted by the TV.

When the **MENU** button is pressed, the On Screen Display (OSD) appears on the PICTURE adjustment page.

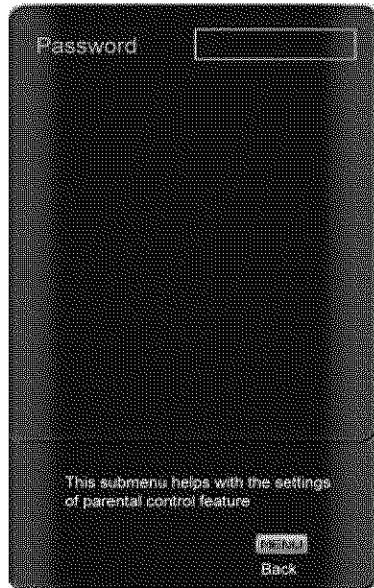

Press the ► button to display the SETUP page.

Press the ▼ button to highlight Parental, and then press the ► button.

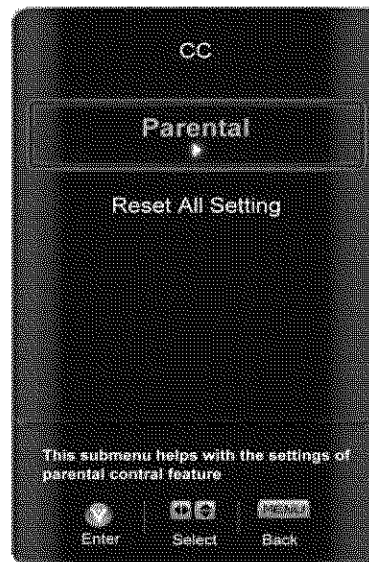

The Password must be entered before the TV will continue with Parental settings. The default password set in the factory is 0 0 0 0. If you are going to use the Parental Control feature you should change the password.

Note: Make sure you write down and store the new password in a secure place. The Reset All Settings feature (see page 66) does NOT reset the password.



4.5.9 Channel Block

Press the **▼** button to highlight the Channel Block selection.

Press the **▶** button to go to the next screen.

Press the **▼** button to highlight the channel you want to block.

Press the **●** button to block the highlighted channel.

Once the adjustments are completed press the **EXIT** button to exit the OSD completely.



4.5.10 US TV Rating

Follow the procedure in the previous section to display the Parental Control menu and then press the **▼** button to highlight the US TV Rating selection.

Press the **▶** button and the Block TV Rating panel will be displayed.

In the Block TV Rating panel you can customize the program blocking of the following TV ratings:

- Y – All children
- Y7 – Older children
- G – General audience
- PG – Guidance suggested
- 14 – Strongly cautioned
- MA – Mature audience

You can also customize the TV ratings for the following content:

- A – All subratings
- D – Sexual dialog
- L – Adult language
- S – Sexual situations
- V - Violence
- FV – Fantasy violence

Press the **▲** or **▼** button to navigate through the TV rating options.

Press the **●** button to block (locked) or allow (unlocked).

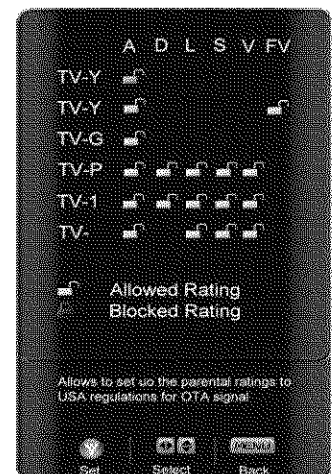

4.5.11 US Movie Rating (For US)

Press the ▼ button to highlight the US Movie Rating selection.

Press the ► button and the Block Movie Rating panel will be displayed.

In the Block Movie Rating panel you can customize the program blocking of the following Movie ratings:

- G – General audience
- PG – Parental guidance suggested
- PG-13 – Recommended for children 13 years of age or older
- R – Mature audience
- NC-17 – No one under 17 years of age
- X – No one under 17 years of age

Press the ▲ or ▼ button to navigate through the Movie rating options.

Press the  button to block (locked) or allow (unlocked).

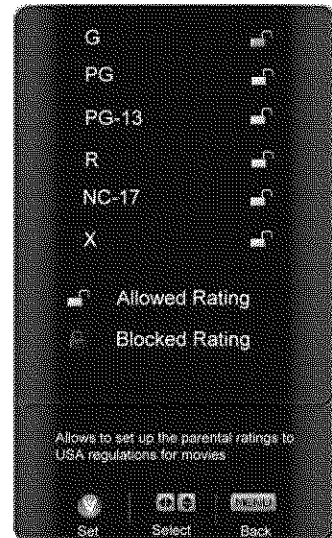

4.5.12 Canadian English Rating

Press the ▼ button to highlight the Canadian English Rating selection.

Press the ► button and the Block Canadian English Rating panel will be displayed.

In the Block Canadian English Rating panel you can customize the program blocking of the following ratings:

- C – Children
- C8+ – Children 8 years or older
- G – General Programming, suitable for all audiences
- PG – Parental guidance
- 14+ – Viewers 14 years or older
- 18+ – Adult programming

Press the ▲ or ▼ button to navigate through the Movie rating options.

Press the  button to block (locked) or allow (unlocked).

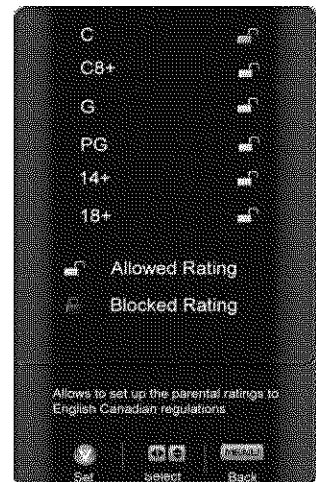

4.5.13 Canadian French Rating

Press the **▼** button to highlight the Canadian French Rating selection.

Press the **▶** button and the Block Canadian French Rating panel will be displayed.

In the Block Canadian French Rating panel you can customize the program blocking of the following ratings:

- G – General audience
- 8 ans+ – General – not recommended for young children
- 13 ans+ – Not suitable for children under 13 years of age
- 16 ans+ – Not suitable for under 16 years of age
- 18 ans+ – Adults only

Press the **▲** or **▼** button to navigate through the Movie rating options.

Press the  button to block (locked) or allow (unlocked).

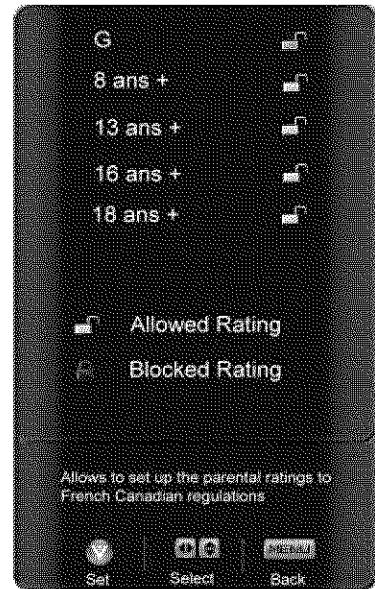

4.5.14 Check for DTV Rating

This option is designed to update the TV or Movie table of different ratings for programs being viewed in your local or regional area. It will allow the parental guidance control feature in your TV to have the most current parental control database for a digital signal. This option may be available in the future for activation. This option works as follows: Whenever you decide to use the Parental Control feature and this option has been activated in your area, the Check for New DTV Rating will be a solid color indicating that an update is available for any rating tables. After entering the password, the Parental menu will appear on the screen, and then do the following.

Observe the status of the **DTV Rating**. If option is faded out, no update is available (the option is not activated in your area).

If it is not faded out, press either **▲** or **▼** button to select this option.

Press **▶** button to execute this operation. Please follow the on screen instructions to complete this procedure.

Press either **▲** or **▼** to select and then adjust any other option in this menu.

Once the adjustments are completed press the **EXIT** button to exit the OSD completely.

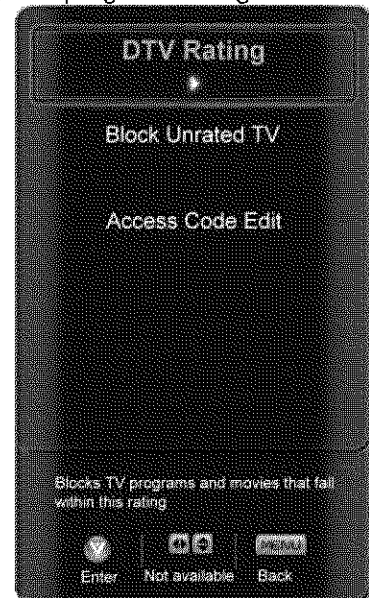

4.5.15 Blocked Unrated Programming

Follow the procedure in the previous section 4.5.8 to display the Parental Control menu and then press the \blacktriangledown button to highlight the Block Unrated TV selection.

Press the \blacktriangleright button to turn-on or turn-off the blocking of programming that does not have a rating.

Once the adjustments are completed press the **EXIT** button to exit the OSD completely.

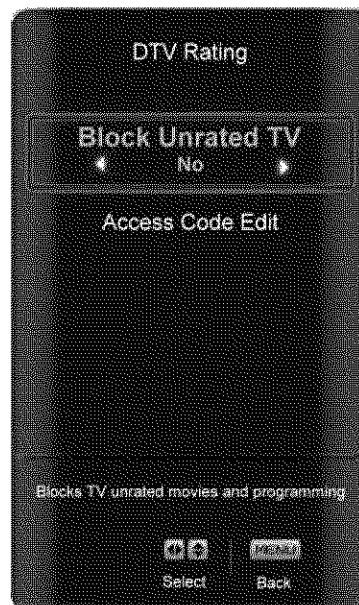

4.5.16 Change the Password

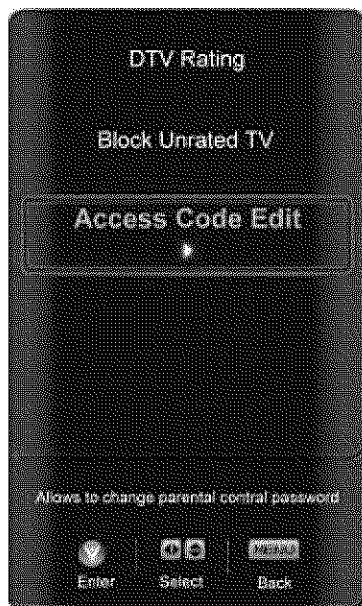

Press the \blacktriangledown button to highlight the Access Code Edit selection.

Press the \blacktriangleright button and the new Password panel will be displayed.

Enter the new, 4-digit password using the number buttons on the remote. Enter it a second time to confirm you entered it correctly.

Once the adjustments are completed press the **EXIT** button to exit the OSD completely.

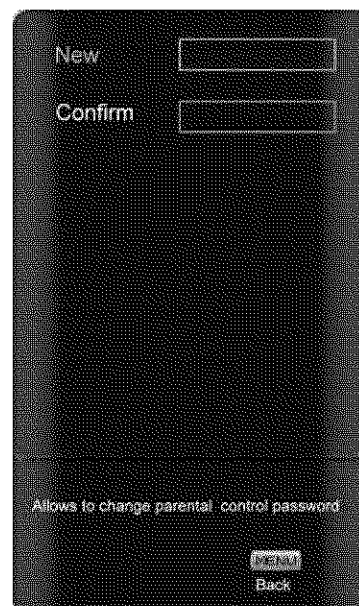

Note: Make sure you write down and store the new password in a secure place. The Reset All Settings feature (see page 66) does NOT reset the password.



4.5.17 Reset All Settings

Press the ▼ button to highlight the Reset All Settings selection.

Press the ► button to reset the TV to the default factory settings.

The screen will display a message to confirm that you want to reset the values to factory settings.

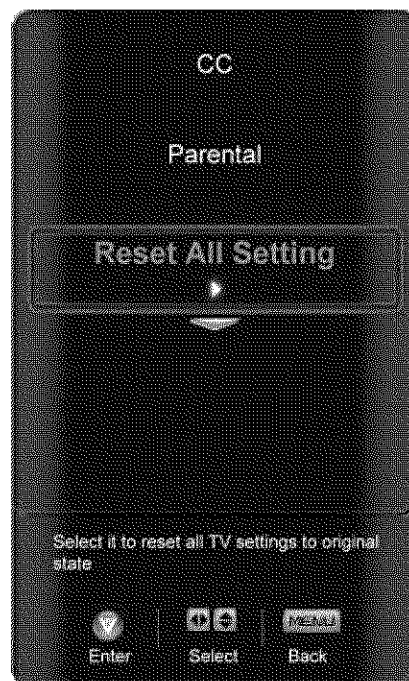

Use the ◀ or ▶ button to highlight your selection.

Press the  button to confirm your choice.

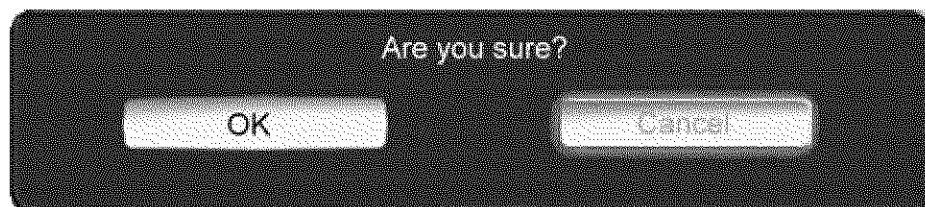

Once the adjustments are completed press the **EXIT** button to exit the OSD completely.

Note: This does NOT reset the Parental Control Password.



4.6 HDMI Input Picture Adjustment

The Picture Adjust menu operates in the same way for the HDMI Input as for the DTV / TV input in section 4.2.

Once the adjustments are completed press the **EXIT** button to exit the OSD completely.

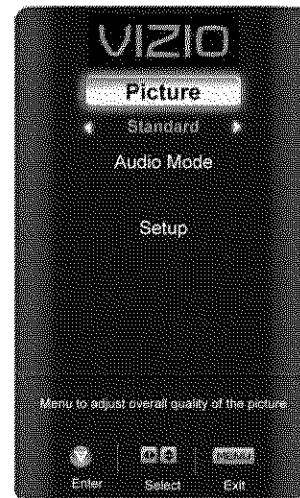

4.7 HDMI Input Audio Adjustment

The Audio Adjust menu operates in the same way for the HDMI Input as for the DTV / TV input in section 4.3.



4.8 HDMI Input Setup

The Setup menu operates in the same way for the HDMI Input as for the TV input in section 4.4. The menu difference is that there is no DTV / TV or Parental Control adjustments.

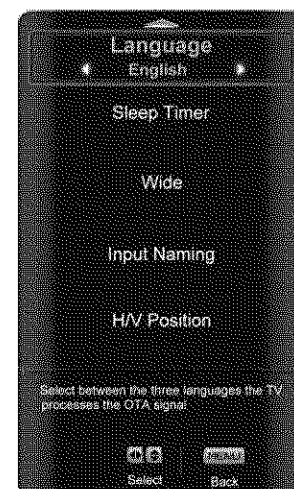

4.9 Video Input Picture Adjustment

The Picture Adjust menu operates in the same way for Video Inputs (Component and AV) as for the DTV / TV input in section 4.2. The menu difference is that there is no icon along the top for DTV / TV adjustments.

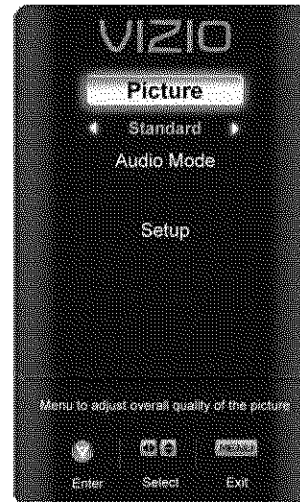

4.10 Video Input Audio Adjustment

The Audio Adjust menu operates in the same way for Video Inputs (Component and AV) as for the DTV / TV input in section 4.3. The menu difference is that there is no icon along the top for DTV / TV adjustments.

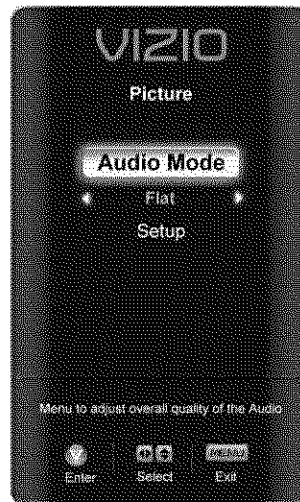

4.11 Video Input Setup

The Setup menu operates in a similar way for Video Inputs (Component and AV) as for the TV input in section 4.4. The menu difference is that there is an auto phase setting under the H/V Position submenu when using Component input.

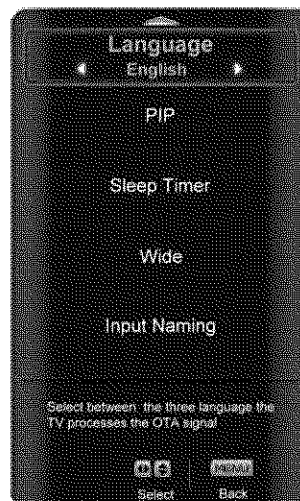

4.12 Auto Phase (for Component Input)

Press the \blacktriangledown button to highlight the H/V Position.

Press the \blacktriangleright button and the new H/V Position submenu will be displayed.

Press the \blacktriangledown button to highlight Auto Phase.

Press the \blacktriangleright button to execute this option. The TV will automatically look for the phase of the signal to fine tune the picture.

Once the adjustments are completed press the **EXIT** button to exit the OSD completely.

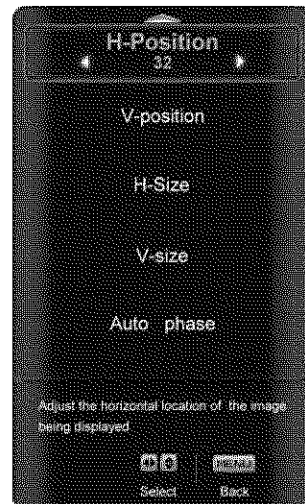

4.13 Video Input Parental Control

The Parental Control menu operates in the same way for Video Inputs (Component and AV) as for the DTV / TV input in section 4.5.8. The menu difference is that there is no icon along the top for DTV / TV adjustments.



4.14 PC Input Picture Adjustment

The Picture Adjust menu operates in the same way for the PC Input as for the DTV / TV input in section 4.2 for Backlight, Contrast, Brightness and Color Temperature.

4.14.1 Auto Adjust

When the **MENU** button is pressed, the On Screen Display (OSD) appears on the PICTURE adjustment page.

Press the **▼** button to highlight the Auto Adjust selection.

Press the **▶** button for the LCD HDTV to adjust to the PC signal timing automatically.

Once the adjustments are completed press the **EXIT** button to exit the OSD completely.

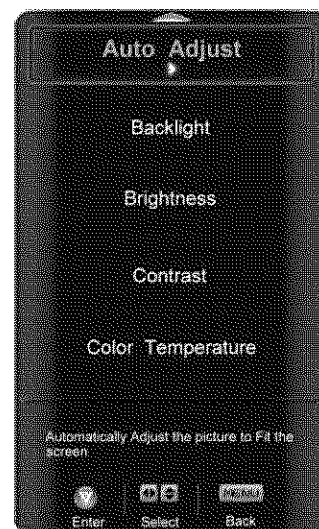

4.14.2 H-Position

Press the **▼** button to highlight the Horizontal Shift selection.

Press the **▶** button to start adjusting the horizontal position of the picture.

Use the **◀** or **▶** button to adjust the horizontal position.

Once the adjustments are completed press the **EXIT** button to exit the OSD completely.

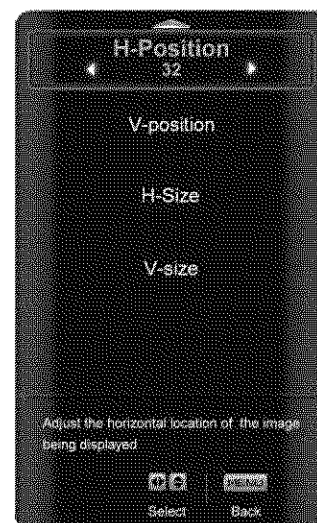

4.14.3 V-Position

Press the **▼** button to highlight the Vertical Shift selection.

Press the **▶** button to start adjusting the vertical position of the picture.

Use the **◀** or **▶** button to adjust the vertical position.

Once the adjustments are completed press the **EXIT** button to exit the OSD completely.



4.14.4 H-SIZE

Press the ▼ button to highlight the H-Size selection.

Press the ► button to start adjusting the horizontal size of the picture.

Use the ◀ or ▶ button to adjust the horizontal size.

Once the adjustments are completed press the **EXIT** button to exit the OSD completely.

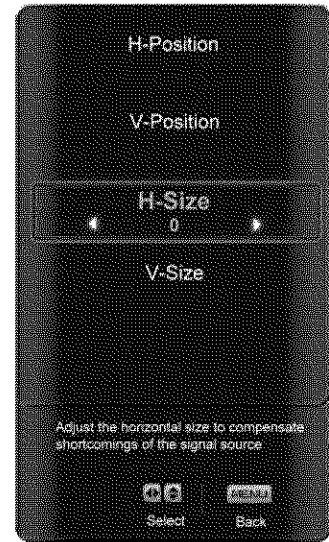

4.14.5 V-SIZE

Press the ▼ button to highlight the H-Size selection.

Press the ► button to start adjusting the horizontal size of the picture.

Use the ◀ or ▶ button to adjust the horizontal size.

Once the adjustments are completed press the **EXIT** button to exit the OSD completely.

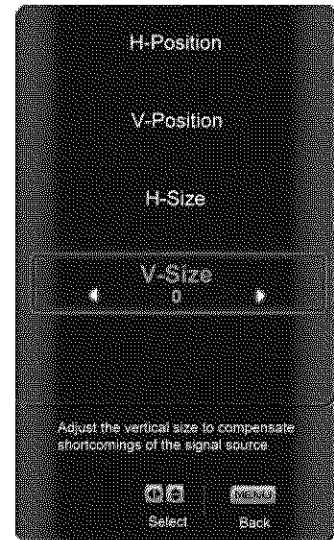

4.14.6 Fine Tune

Press the ▼ button to highlight the Fine Tune selection.

Press the ► button to start tuning the to the PC signal.

Use the ◀ or ▶ button to adjust the tuning.

Once the adjustments are completed press the **EXIT** button to exit the OSD completely.

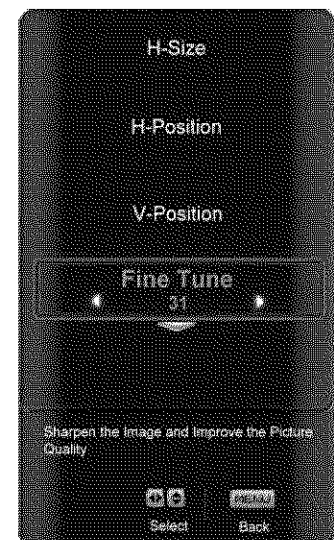

4.15 PC Input Audio Adjustment

The Audio Adjust menu operates in the same way for the PC Input as for the DTV / TV input in section 4.3. The menu difference is that there are no icons along the top for DTV / TV and Parental Control adjustments.

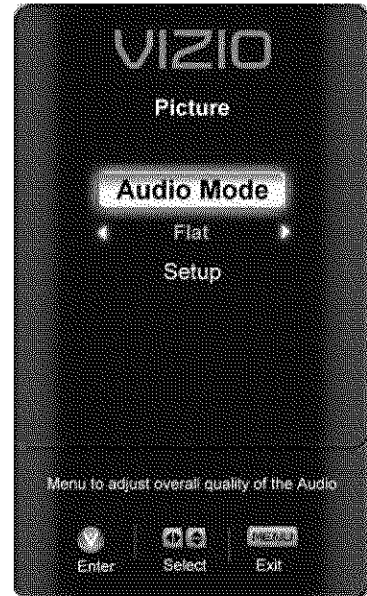

4.16 PC Input Setup

The Setup menu operates in the same way for the PC Input as for the DTV / TV input in section 4.4. The menu difference is that there is no icon along the top for TV adjustments and no Closed Caption.

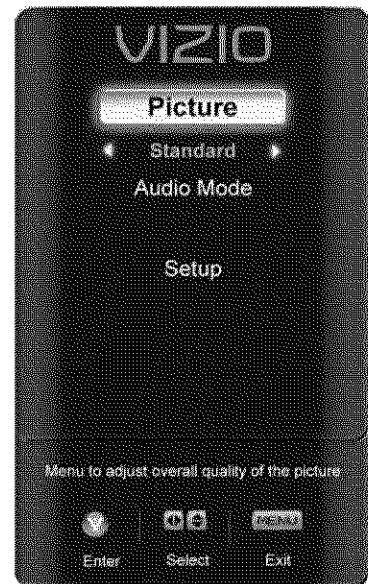

4.17 Understanding Viewing Features

Your HDTV features the following viewing modes. You can switch viewing modes using the remote control, please follow the instructions in page 37.

4.17.1 Viewing Modes

Normal Mode

The original 4:3 aspect ratio (1.33:1 source) is preserved, so black bars are added to the left and right of the display image. Standard TV broadcasts are displayed with a 4:3 Aspect Ratio. Movies in 4:3 Aspect Ratio may be referred to as pan-and-scan or full frame. These movies were originally filmed in 16:9 (widescreen), and then modified to fit a traditional TV screen (4:3).

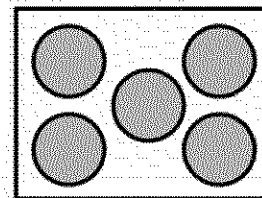

Wide Mode

When watching a standard broadcast or full-frame movie in this mode, the display image is stretched proportionately to fill the TV screen. When watching a widescreen (1.78:1 source) program or movie, the display image fills the TV screen. If you are watching a widescreen (1.85:1 or 2.35:1 source) program or movie, there will still be black bars at the top and bottom.

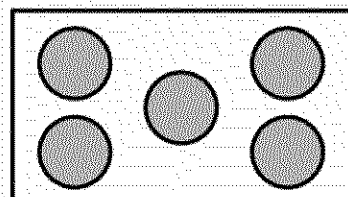

Panoramic Mode

When watching a standard broadcast or full frame movie in this mode, the 4:3 Aspect Ratio (1.33:1 source) display image is stretched horizontally on the left and right sides to fill the TV screen. The center of the image is not stretched.

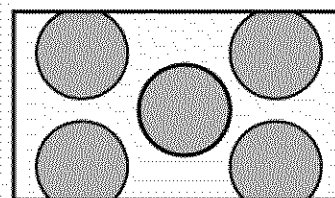

Zoom Mode

When watching a widescreen (1.78:1, 1.85:1, or 2.35:1 source) program or movie, the display image is zoomed proportionally to fill the width of the screen. The top and bottom are cut off to remove most of the source material's black bars. This mode is good for programs or movies with sub-titles.

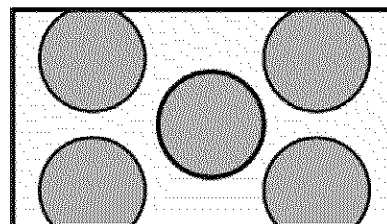

4.17.2 Picture-In-Picture (PIP) Mode

Your TV features PIP mode so you can watch two pictures at the same time. When PIP is turned on, you can display two pictures at one time. One picture is displayed as the full screen (main screen) and the other picture is displayed in a small window (sub screen). The sub-screen can be set to small, medium or large.

See below for detailed information regarding the PIP sources.

MAIN \ SUB	SUB											
	DTV	TV	AV1	AV2	Component 1	Component 2	HDMI1	HDMI2	HDMI3	HDMI4	RGB	
DTV					✓	✓	✓	✓	✓	✓	✓	✓
TV					✓	✓	✓	✓	✓	✓	✓	✓
AV1					✓	✓	✓	✓	✓	✓	✓	✓
AV2					✓	✓	✓	✓	✓	✓	✓	✓
Component 1	✓	✓	✓	✓			✓	✓	✓	✓		
Component 2	✓	✓	✓	✓			✓	✓	✓	✓		
HDMI 1	✓	✓	✓	✓	✓	✓						✓
HDMI 2	✓	✓	✓	✓	✓	✓						✓
HDMI 3	✓	✓	✓	✓	✓	✓						✓
HDMI 4	✓	✓	✓	✓	✓	✓						✓
RGB	✓	✓	✓	✓			✓	✓	✓	✓		

“✓” – Indicates which inputs are available for PIP and POP modes.

4.17.3 Adjusting Basic PIP Settings

The PIP channel is independent of the main TV channel. To change the PIP channel, press the PIP CH button on the remote control. Alternatively, you can change the PIP channel by pressing the CH+ or CH- button.



Repeated pressing of the PIP button will turn on, turn off the PIP mode.

Press the PIP SIZE button to alternate between Small, Medium and Large PIP sizes.

Repeated pressing of the PIP INPUT button will cycle through the inputs for PIP. This button has no effect when PIP is off.

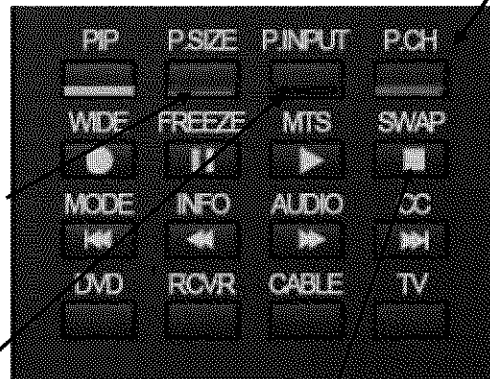

You can swap the program that is in the main picture with the program in the PIP sub-picture. To swap the main picture program with the PIP sub-picture program, press SWAP on the remote control. If you press SWAP again, it will return the program to the main picture.



Programming the VIZIO Universal Remote Control

You can program the remote control to work with up to four different pieces of equipment including your VIZIO SV470XVT1A. Listed below are the steps for programming your VCR, Cable Box and DVD Player.

4.17.4 Programming for VCR

1. Manually turn on the VCR.
2. Press the VCR button on the remote control.
3. Press and hold the SET button until the LED LIGHT flashes twice.
4. Find the programming code for your VCR in the code list in the back of this book and enter it using the Number Buttons. If the code is accepted, the LED flashes twice after the last digit is entered.
If the LED does not flash twice, repeat Steps 2 through 4 with the next code listed for the component and manufacturer.
5. Point the remote control at the VCR and press the POWER button. The VCR will turn off.

Note:

- a) If your VCR does not respond, try all the codes for your VCR brand. If the codes do not work, or your brand is not listed, see "Searching for Component Codes."
- b) Sometimes a code listed will only include limited functions. Try other codes that may include more functionality.

4.17.5 Programming for Cable Set-Top Box

1. Manually turn on the Cable Box.
2. Press the CBL button on the remote control.
3. Press and hold the SET button until the LED LIGHT flashes twice.
4. Find the programming code for your Cable Box in the code list in the back of this book and enter it using the Number Buttons. If the code is accepted, the LED flashes twice after the last digit is entered.
If the LED does not flash twice, repeat Steps 2 through 4 with the next code listed for the component and manufacturer.
5. Point the remote control at the Cable Box and press the POWER button. The Cable Box will turn off.
If the LED does not flash twice, repeat Steps 2 through 4 with the next code listed for the component and manufacturer.

Note:

- a) If your Cable Set-Top Box does not respond, try all the codes for your brand. If the codes do not work, or your brand is not listed, see "Searching for Component Codes."
- b) Sometimes a code listed will only include limited functions. Try other codes that may include more functionality.



4.17.6 Programming for DVD Player

1. Manually turn on the DVD Player.
2. Press the DVD button on the remote control.
3. Press and hold the SET button until the LED LIGHT flashes twice.
4. Find the programming code for your DVD player in the code list in the back of this book and enter it using the Number Buttons. If the code is accepted, the LED flashes twice after the last digit is entered.
If the LED does not flash twice, repeat Steps 2 through 4 with the next code listed for the component and manufacturer.
5. Point the remote control at the DVD Player and press the POWER button. The DVD Player will turn off.

Note:

- a) If your DVD player does not respond, try all the codes for your brand. If the codes do not work, or your brand is not listed, see "Searching for Component Codes."
- b) Sometimes a code listed will only include limited functions. Try other codes that may include more functionality.

4.17.7 Searching for Component Codes

If you cannot find the manufacturer in the component list or the program code does not work, you can use the remote control to search for the correct component code.

To search for a component code:

1. Turn on the component.
2. Press the matching component button on the remote control.
3. Press and hold the SET button until the LED flashes twice.
4. Press 9 9 1. The LED flashes twice.
5. Point the remote control at the component and then alternate between pressing the POWER button and the component button on the remote control until the component turns off. If the component still does not respond, clear the component button, then repeat the search procedure.

4.18 Using a Cable or Satellite Remote

Your VIZIO remote uses codes 000, 047, 050, 067, 329, 331 and 339 to work your LCD HDTV. To use a cable or satellite remote to work the LCD HDTV, refer to your cable or satellite remote user guide for more information on how to program the remote. If your cable or satellite remote uses a 5-digit code (like most Direct TV units), first try 11758 and then, if that does not work, 10178. If your cable or satellite remote uses a 4-digit code, try 1758 and then 0178 as an alternative. If your cable or satellite remote uses a 3-digit code (EchoStar or Dish Network for example), use code 627.

Note: Some buttons may not function as expected on your cable or satellite remote. Typically power, volume and mute will work.



Chapter 5 Maintenance and Troubleshooting

5.1 Maintenance

Important

1. Make sure that the power cable is removed from the socket before cleaning the TV.
2. Do not use volatile solvent (such as toluene, rosin and alcohol) to clean the TV. Such chemicals may damage the housing, screen glass and remote control, and cause paint to peel.

Cleaning the Housing and Remote Control

1. Use the VIZIO soft cloth for cleaning.
2. If the housing or remote control is seriously contaminated, use a soft cloth moistened with diluted neutral cleaner to clean the display. Wring water out of the cloth before cleaning to prevent water from penetrating into the housing. Wipe the display with a dry cloth after cleaning.

Cleaning the Screen

1. Use the VIZIO soft cotton cloth to gently clean the screen.
2. The screen glass is very fragile. Do not scrape it with any sharp object. Do not press or tap the screen to avoid cracking. When the screen is seriously contaminated, use a soft cloth moistened with diluted neutral cleaner to clean the display. Wring water out of the cloth before cleaning to prevent water from penetrating into the housing. Wipe the display with a dry cloth after cleaning.

5.2 Troubleshooting Guide

If the TV fails or the performance changes dramatically, check the display in accordance with the following instructions. Remember to check the peripherals to pinpoint the source of the failure. If the display still fails to perform as expected, contact the VIZIO for assistance by calling 1-877-698-4946 or e-mail us at techsupport@vizio.com.

Problem	Solution
No power.	<p>Make sure the power button is ON (White VIZIO Logo).</p> <p>Make sure AC power cord is securely connected to the AC socket.</p> <p>Plug another electrical device (like a radio) to the power outlet to verify that the outlet is supplying the proper voltage.</p>
No sound.	<p>Check your audio connection</p> <p>Press MUTE on the remote control again, so that MUTE disappears from the screen</p> <p>Check your audio settings, your TV audio may be set to SAP, min or speakers off.</p> <p>Press the Volume + (Up) key on your remote control</p> <p>Make sure that headphones are not connected</p>
If the screen is black.	Check your input connections.
Power is ON but no screen	Make sure the video cable supplied with the TV is secured to the correct video



Problem	Solution
image.	output port on the back of the VCR and the TV. Make any cable you have attached to the TV is secured to the correct output your Set-Top Box, DVD, etc. Adjust brightness and contrast. Check Source settings.
Wrong or abnormal colors appear.	If any colors (red, green, or blue) are missing, check the video cable to make sure it is securely connected.
Control buttons do not work.	Press only one button at a time.
Remote Control does not work.	Make sure batteries are inserted correctly Batteries could be weak. Make sure you have selected TV on the remote.
There appears to be image quality issues.	For best image quality, view HD wide screen programs where possible. If HD content is not available view "Standard Definition" from a digital source. Standard, analog TV will always be noticeably inferior to HD because your digital flat panel TV has video that is many times better than old TV's and so you can see interference and deficiencies you did not know you had.
You cannot see a picture.	Make sure that the power cord is plugged into a grounded electrical outlet. Make sure that the power button is turned on. Make sure that the selected input source is connected to a working input source. If your TV is connected to your computer in RGB or HDMI mode, press any key on your keyboard to "wake" your computer.
You see a distorted picture or hear unusual sound.	You may be getting interference from electrical appliances, cars, motorcycles, or fluorescent lights. If you have not mounted it on the wall, try moving your TV to another location to see if this is the cause of the problem.
The picture has abnormal patterns.	Make sure that the input source cable is attached securely and correctly to the back of your TV. Make sure that the video input source is within the range of your TV. Compare the video input source's specifications with your TV specifications.
The display image does not cover the entire screen.	If you are using RGB mode, make sure that H Size and V Position in the On Screen Display (OSD) are set correctly. If you are using TV, AV1, AV2 or Component with 480i input, use the WIDE button on the remote control to scroll through various screen modes.
You can see a picture but you cannot hear sound.	Make sure that the volume is not turned down. Make sure that the sound is not muted. Make sure that your audio input source cables are connected securely and correctly.
The TV has pixels that are always dark or colored.	Your LCD HDTV is manufactured using an extremely high level of precision technology, however, sometimes some pixels of your LCD HDTV may not display. Pixel defects within industry specifications are inherent to this type of product and do not constitute a defective product.
You see "noise" or "trash" on the screen.	When your LCD HDTV's digital capabilities exceed a digital broadcast signal, the signal is up-converted (increased) to match your TV's display capabilities. Up-converting can cause noise or trash.
You switch to a different input and the volume changes.	The TV remembers the volume level from the last time you adjusted it. If the sound level is higher or lower from another source, then the loudness will change.
Tips for High-Definition Users.	The LCD HDTV is an ideal platform for viewing High Definition Content. Best Image Quality will be achieved by the HDMI Input, then YPbPr, then RGB. However, due to variances in broadcast practices, it is possible some image distortions can occur.



Problem	Solution
Tips for Letterbox Content Users.	Letterboxed (or "Widescreen") versions of DVD movies are most commonly formatted for standard 4:3 Televisions. The LCD HDTV has the capability of expanding this content so the entire screen is filled at the expense of image accuracy. To use this function, press the "ZOOM" key on the remote control and cycle among the available options.

5.3 Wireless Speakers System and TV Pairing

If pairing of the Wireless Speakers System is needed, please follow the steps below:

1. Make sure that the slide switch in the Tx Card is to the ID position and insert it into TV slot.
2. Plug AC Power cord into subwoofer, subwoofer LED power indicator will flash intermittently.
3. Press and hold down the Channel Search button at the back side of the Subwoofer for approximate 5 seconds; a long beep will be heard.
4. Light of the LED indicator will stop flashing and a solid light will be displayed. Pairing is done.
5. To have the two sets working as one, please take the Tx Card out from the slot. Slide the switch to the Play position and reinsert it into the TV slot.
6. Your TV and Wireless Speakers System have become now a Dolby 5.1 theatre entertainment system.

5.4 Telephone & Technical Support

Products are often returned due to a technical problem rather than a defective product that may result in unnecessary shipping charges billed to you. Our trained support personnel can often resolve the problem over the phone. For more information on warranty service or repair, after the warranty period, please contact our Support Department at the number below.

Customer support and quality service are integral parts of VIZIO's commitment to service excellence.

For technical assistance contact our VIZIO Technical Support Department via e-mail or phone.

E-mail: techsupport@vizio.com

Tel: (877) 698-4946 Fax: (949) 585-9563

Hours of operations:

6:00am – 9:00pm PST Monday – Friday

8:00am – 4:00pm PST Saturday – Sunday

Please have your VIZIO model number, serial number and date of purchase available before you call.

VIZIO

39 Tesla

Irvine CA 92618

Tel: (949) 428-2525 Fax: (949) 585-9514

Web: www.VIZIO.com



5.5 Compliance

Caution: Always use a power cable that is properly grounded. Please use the AC cords listed below for each area.

USA	UL
Canada	CSA
Germany	VDE
UK	BASE/BS
Japan	Electric Appliance Control Act

5.6 FCC Class B Radio Interference Statement

NOTE: This equipment has been tested and found to comply with the limits for a Class B digital device, pursuant to Part 15 of the FCC Rules. These limits are designed to provide reasonable protection against harmful interference in a residential installation. This equipment generates, uses and can radiate radio frequency energy, and if not installed and used in accordance with the instructions, may cause harmful interference to radio communications. However, there is no guarantee that interference will not occur in a particular installation. If this equipment does cause harmful interference to radio or television reception, which can be determined by turning the equipment off and on, the user is encouraged to try to correct the interference by one or more of the following measures:

1. Reorient or relocate the receiving antenna.
2. Increase the separation between the equipment and receiver.
3. Connect the equipment into an outlet on a circuit different from that to which the receiver is connected.
4. Consult the dealer or an experienced radio/TV technician for help.

Notice:

1. The changes or modifications not expressly approved by the party responsible for compliance could void the user's authority to operate the equipment.
2. Shielded interface cables and AC power cord, if any, must be used in order to comply with the emission limits.
3. The manufacturer is not responsible for any radio or TV interference caused by unauthorized modification to this equipment. It is the responsibilities of the user to correct such interference.



Chapter 6 Miscellaneous Information

6.1 Specifications

Specifications	
Panel	47" Diagonal, 16:9 Aspect Ratio
Resolution	1920 x 1080 pixels
Pixel (Dot) Pitch	0.5415 mm x 0.5415 mm
Display Compatibility	1080P (Full HDTV)
Colors	1.06 Billion
Brightness	500 cd/m ² (typical)
Contrast	1300 :1 (typical), 6500 :1 (with DCR)
Response Time	5ms (typical)
Viewing Angle	Horizontal and Vertical 178° (typical)
Inputs	1x Coaxial RF (ATSC/QAM/NTSC), 4x HDMI™** with HDCP (1 with Stereo Audio RCA), 2x Component YPbPr plus Stereo Audio, 1x RGB PC plus Stereo Audio (1/8" stereo jack), 2x Composite Video plus Stereo Audio, 1x S-Video plus Stereo Audio
Outputs	1x Optical Audio (SPDIF Optical), 1x Stereo Audio (RCA)
Features	FULL HD, PIP, POP, Noise Reduction, CC, V-Chip, 3D Comb Filter, Freeze, Support Motion Enhancement and Motion Correction, Picture Enhancement, MPEG-2 Decoding via DTV input, NTSC Video decoding via Video (AV, S-Video or Component), Progressive Scan Video via HDMI™**, Component or RGB, HDTV via HDMI™**, Component or RGB (Set-Top Box required), Computer 640x480, 800x600, 1024x768, 1280x1024, 1920x1080 via RGB or 1920x1080 via HDMI, Built-in SRS (TruSurroundXT) Audio, Supports 1080P (Full HDTV), 1080i (HDTV), 720P (HDTV), 480P (EDTV) and 480i (SDTV) video signals. 1080P FHDTV, HDMI V.1.3, 120 Hz Motion Estimation & Motion Compensation, 3.0 channel audio, built-in Dolby Digital Decoding, upgradeable to 5.1 Dolby Surround sound speakers w/ wireless linked subwoofer.
Speakers	3 x 10 W
Panel Life	50,000 hours to half the original brightness
Power	
Input	IEC Connector for direct power line connection
Voltage Range	100 ~ 240Vac at 50/60Hz
Power Consumption	400W
Environmental Conditions	
Operating	Temperature: 5°C~35°C, Relative Humidity: 20~80%, Altitude: 0~14,000 ft
Non-Operating	Temperature: -20°C~50°C, Relative Humidity: 10~90%, Altitude: 0~40,000 ft
Dimensions	43.9" W x 29.7" H x 10" D with stand; 43.9" W x 28.1" H x 4" D without stand
Net Weight	62.4lbs with stand, 56.9lbs without stand
Gross Weight	77.8lbs
Certifications	CSA, CSA-us, FCC class B

*Product specifications may change without notice or obligation.



6.2 Glossary - Standard Definitions

Analog TV: Today's TV system using radio frequency waves to transmit and display pictures and sound.

Aspect Ratio (4x3): Traditional TV "aspect ratio", that is, the screen's width as compared to its height. For example, a "32 inch TV screen" would be 25 inches wide and 19 inches tall.

Aspect Ratio (16x9): "Wide screen TV" aspect ratio which is more like a movie screen than a traditional TV. For example, a "32 inch TV screen" would be 28 inches wide and 16 inches tall.

Digital TV (DTV): Television delivered and displayed using radio frequency waves that contain information that is digitally encoded for improved quality and efficiency.

Enhanced Definition TV (EDTV): A better digital television transmission than SDTV with at least 480P, in a 16x9 or 4x3 display and Dolby digital surround sound. 480P is the quality used by most DVD players. EDTV provides 300-400,000 pixels.

HDTV Monitor (sometimes called HDTV Ready): A set that can display HDTV programming if you have a separate HDTV tuner, HD Cable Set-Top Box or HD Satellite Set-Top-Box Receiver.

HDTV Tuner (also decoder, receiver, set-top box): A device capable of receiving and outputting HDTV signals for display. It may be stand-alone or integrated in the set.

High-Definition Television (HDTV): The best quality picture, wide screen (16x9) display with at least 720 progressively scanned lines (720P) or 1080 interlaced lines (1080i) and Dolby digital surround sound. HDTV provides 900,000-2.1 million pixels.

Integrated HDTV: An HDTV that has the digital tuner built into the set. It does not need a separate set-top box to receive over-the-air DTV signals.

Interlace Scan: A way to scan vertical lines onto a TV picture by scanning all the odd lines first, then filling the in the even lines (this happens instantaneously).

Plug-and-Play or Digital Cable Ready: A DTV or other device for digital cable consumers that plugs directly into the cable jack and does not require a separate set-top box. Plug-and-Play TV owners must obtain a CableCARD from their cable company in order to view scrambled programming services.

Progressive Scan: A way to scan vertical lines onto a TV picture by scanning all the lines consecutively (progressively).

Standard Definition TV (SDTV): Basic digital television transmission that may be displayed with fewer than 480 progressively scanned lines (480P) in 16 x 9 or 4 x 3 format. 480 interlaced (480i) is the quality of today's analog TV system.

Source: Buying a Digital Television, CEA, HDTV Guide, 2005

Note: The Federal Communications Commission (FCC), the Consumer Electronics Association (CEA) and the Consumer Electronics Retailers Coalition (CERC) have made a new tip sheet available for digital television (DTV) retailers to reproduce and distribute to consumers on the sales floor. The file may be downloaded online at www.dtv.gov. While you're there, check out the other useful information in the FCC is making available to consumers interested in learning more about the analog to digital transition.



6.3 Index

A

- Accessories, 5
- Adjustments
 - Closed Caption, 15
 - Selecting the Screen Size, 15, 37, 82
 - Stepping through TV Channels, 37
 - Volume, 10, 37, 77
- Advanced Video Features
 - Black Level Extender, 42
 - Color Temperature (Color Temperature, 43
 - CTI (Color Transient Improvement, 43
 - DNR (Dynamic Noise Reduction, 42
 - Flesh Tone, 43

C

- Cleaning your VIZIO TV, 77
- Co-axial RF
 - Connecting for DTV, 21
 - Connecting for TV, 22
- Component
 - Connecting your Cable Box, 20
 - Connecting your DVD Player, 25
 - Connecting your Satellite Box, 20
- Composite (AV)
 - Connecting your DVD Player, 26, 27
 - Connecting your VCR, 28
 - Connecting your Video Camera, 28
- Controls, 10
 - Side Panel, 10

D

- DTV
 - Audio Adjustment, 46
 - Parental Control, 61
 - Picture Adjustment, 40
 - Special Features, 55
 - Tuner Setup, 52
- DTV Audio Adjust
 - Equalizer, 46
- DTV Audio Adjust
 - Volume, 46
- DTV Audio Adjust
 - Balance, 46
- DTV Audio Adjust
 - Digital Audio Out, 47
- DTV Audio Adjust
 - Speakers, 47
- DTV Audio Adjust
 - Line Out, 47
- DTV Audio Adjust
 - Lip Sync, 47
- DTV Audio Adjust
 - Reset Audio Mode, 51
- DTV Picture Adjust

- Advanced Video, 42
- Backlight, 40
- Brightness, 40
- Color, 41
- Contrast, 41
- Reset Picture Mode, 45
- Sharpness, 42
- Tint, 41
- DTV Special Features
 - Digital Closed Caption, 59
 - Input Naming, 58
 - Language, 55
 - PIP, 55
 - Reset, 66
 - Sleep Timer, 55, 57
 - Wide, 57
- DTV Tuner Setup
 - Auto Search, 52
 - Daylight Saving, 54
 - MTS, 53
 - Partial Channel Search, 53
 - Skip Channel, 53
 - Time Zone, 54
 - Tuner Mode, 52
- DVI
 - Connecting your Cable Box, 19
 - Connecting your DVD Player, 24
 - Connecting your Satellite Box, 19

G

- Glossary, 82

H

- HDMI
 - Connecting your Cable Box, 18
 - Connecting your DVD Player, 23
 - Connecting your Satellite Box, 18
- HDMI Input
 - Audio Adjustment, 67
 - Picture Adjustment, 67
 - Setup, 67

I

- Inputs
 - Antenna, 3
 - Connectors, 17
 - Side Label, 12
- Installation
 - Base removal, 6
 - Preparation, 5
 - Safety Strap, 5
 - Wall Mounting, 5, 6, 32



O

OSD

- Brightness Adjustment, 81
- Closed Caption Selection, 15
- Color Adjustment, 17
- Contrast Adjustment, 81

Outputs

- Using 5.1 Surround with a Home Theatre System, 29
- Using an external Receiver/Amp, 29

P

Parental Control

- Block Unrated Programming, 65
- Canadian English Rating, 63
- Canadian French Rating, 64
- Channel Block, 62
- Check for New DTV Rating, 64
- Movie Rating, 63
- Password change, 65
- TV Rating, 62

PC Input

- Audio Adjustment, 72
- Auto Adjust, 70
- Picture Adjustment, 70
- Setup, 72

PC Picture Adjust

- Fine Tune, 71
- H/V Position, 60
- Horizontal Position, 60, 70
- Horizontal Size, 60, 71
- Vertical Position, 60, 70

PIP and POP Inputs, 74

R

Remote

- Batteries, 16
- Range, 16

Remote Control

- Programming to work your DVD Player, 76
- Programming to work your Set-Top Box, 75
- Programming to work your VCR, 75
- Using your Cable or Satellite Remote to Operate your VIZIO TV, 76

RGB

- Connecting your PC, 30

S

Screen Size explanation, 73

S-Video

- Connecting your DVD Player, 26, 27

T

Technical Specifications, 81

Troubleshooting Guide, 77

TV

- Audio Adjustment, 46
- Parental Control, 61
- Picture Adjustment, 40
- Special Features, 55

TV Audio Adjust

- Balance, 46
- Digital Audio Out, 47
- Equalizer, 46
- Line Out, 47
- Lip Sync, 47
- Reset Audio Mode, 51
- Speakers, 47
- Volume, 46

TV Picture Adjust

- Advanced Video, 42
- Backlight, 40
- Brightness, 40
- Color, 41
- Contrast, 41
- Reset Picture Mode, 45
- Sharpness, 42
- Tint, 41

TV Special Features

- Closed Caption, 59
- Input Naming, 58
- Language, 55
- PIP, 55
- Reset, 66
- Sleep Timer, 55, 57
- Wide, 57

TV Tuner Setup, 52

- Auto Search, 52
- MTS, 53
- Partial Channel Search, 53
- Skip Channel, 53
- Tuner Mode, 52

V

Video Input

- Audio Adjustment, 68
- Auto Phase, 69
- Parental Control, 69
- Picture Adjustment, 68
- Setup, 68

W

Watching TV

- Basic Adjustments, 37
- Basic connections, 32
- First Startup, 32
- Getting your Programs, 36
- Program Information, 38
- Status Information, 38



VIZIO LIMITED PRODUCT WARRANTY

VIZIO provides a "ONE-YEAR LIMITED WARRANTY" against manufacturing defects in materials and workmanship to the original purchaser of a new VIZIO display purchased from an authorized VIZIO U.S. reseller and used in the fifty (50) United States or Puerto Rico.

VIZIO's Responsibility

VIZIO displays purchased new from an authorized VIZIO U.S. reseller and that are used in the fifty (50) United States or Puerto Rico are warranted to be free from manufacturing defects in materials and workmanship for one (1) year from the date of the original retail purchase. If the display fails to conform to this limited warranty, VIZIO will, at its option and sole discretion, repair or replace the display.

Labor

During the one-year limited warranty period, VIZIO will provide, when needed, service labor to repair a manufacturing defect. Repairs required on displays which are thirty (30) inches and larger generally will be made "on-site" where the display is installed. The determination for performing the on-site repair is dependent upon the manufacturing defect and is at VIZIO's option and sole discretion. Repairs required on displays which are less than thirty (30) inches generally will be performed at a VIZIO service center.

Parts

Repairs may be made with new or recertified parts, or the entire unit may be replaced with a new or recertified unit, at VIZIO's option and sole discretion. Replacement parts or replacement units provided under this limited warranty are warranted for the remaining portion of the original warranty period, or for ninety (90) days from warranty service or replacement, whichever is later.

How to Obtain Warranty Service

To obtain warranty service, contact VIZIO Technical Support via email at TechSupport@VIZIO.com, via phone at 877-MYVIZIO (877-698-4946), or via postal mail at VIZIO Technical Support, 39 Tesla, Irvine, CA 92618. You must provide the model, serial number, and date of purchase. VIZIO Technical Support is available from 6:00AM to 9:00PM Pacific Time, Monday through Friday, and 8:00AM to 4:00PM Pacific Time, Saturday and Sunday. Please note that holiday hours may vary. For up to date information, please visit www.VIZIO.com.

VIZIO reserves the right to assess all warranty claims and to determine if defects or damages are covered by this limited warranty. In case of a claim that is not covered by this warranty, you will be contacted to determine whether VIZIO should repair the damage for a fee or whether the product should be returned to you as received by the service technician or service center.

Parts and service labor that are VIZIO's responsibility under this limited warranty will be provided without charge. All other service is at the customer's expense. VIZIO reserves the right to charge the customer for any service call for anything not covered by this limited warranty. Before you ask for warranty service, please review your User Manual. You may avoid a service call and a service charge.

Please refer to the reverse side of this page for additional information regarding how to obtain warranty service.

PLEASE DO NOT RETURN YOUR UNIT TO VIZIO WITHOUT PRIOR AUTHORIZATION.

Not Covered

This limited warranty does not cover the following: cosmetic defects; damage, malfunctions or failures resulting from shipping or transit, improper or faulty installation, abuse, operation contrary to furnished instructions, operation on incorrect power supplies, products not supplied by VIZIO, modification, alteration, improper servicing or tampering; damage from fire, water, lightning, power surges, abnormal environmental conditions or other acts of nature; normal wear and tear; unsatisfactory visual or audio performance not caused by a manufacturing defect; or displays with a missing or unreadable serial number. Operation of the display for commercial purposes or in applications or uses for which the display is not intended is not covered by this limited warranty. "Image Sticking", caused by static images on the screen for extended periods and or excessive brightness and contrast



levels, is not covered by this limited warranty. Installation, removal, transportation and reinstallation of a display, and routine maintenance and cleaning, are not covered by this limited warranty.

THERE ARE NO EXPRESS WARRANTIES OTHER THAN THOSE LISTED OR DESCRIBED ABOVE. ANY IMPLIED WARRANTIES, INCLUDING ANY IMPLIED WARRANTY OF MERCHANTABILITY AND FITNESS FOR A PARTICULAR PURPOSE, SHALL BE LIMITED IN DURATION TO THE PERIOD OF TIME SET FORTH ABOVE. VIZIO'S TOTAL LIABILITY FOR ANY AND ALL LOSSES AND DAMAGES RESULTING FROM ANY CAUSE WHATSOEVER, INCLUDING VIZIO'S NEGLIGENCE, ALLEGED DAMAGE, OR DEFECTIVE GOODS, WHETHER SUCH DEFECTS ARE DISCOVERABLE OR LATENT, SHALL IN NO EVENT EXCEED THE PURCHASE PRICE OF THE DISPLAY. VIZIO SHALL NOT BE RESPONSIBLE FOR LOSS OF USE, COMMERCIAL LOSS, LOST REVENUE OR LOST PROFITS, OR OTHER INCIDENTAL OR CONSEQUENTIAL DAMAGES. SOME STATES DO NOT ALLOW LIMITATIONS ON HOW LONG AN IMPLIED WARRANTY LASTS OR THE EXCLUSION OR LIMITATION OF INCIDENTAL OR CONSEQUENTIAL DAMAGES, SO THE ABOVE LIMITATIONS OR EXCLUSIONS MAY NOT APPLY TO YOU.

This warranty gives you specific legal rights, and you may also have other rights, which vary from state to state. This is the only warranty applicable; no one is authorized to extend or modify it or to grant any other warranty on VIZIO's behalf.

Owner's Responsibility

To ensure warranty service, keep the dated bill or sales receipt as evidence of the purchase date and location. This limited warranty applies only to original purchaser and is non-transferable.

Warranty service conditions are subject to change. For the latest Warranty Terms and Conditions and additional information regarding VIZIO's Limited Product Warranty, please see complete details online at www.VIZIO.com.



VIZIO RETURN POLICY

VIZIO's return policy allows for products purchased directly from VIZIO to be returned by the original purchaser during the initial thirty (30) day period following the date of purchase. A VIZIO return authorization number must first be obtained as provided below. The refund will be the purchase price actually paid by the purchaser less a ten percent (10%) restocking fee per each item returned. Shipping and handling are not refundable.

The return authorization number must first be obtained from VIZIO's Customer Service by emailing CustomerSupport@VIZIO.com or by calling 949-428-2525, 6:00AM to 9:00PM Pacific Time, Monday through Friday, and 10:00AM to 2:00PM Pacific Time, Saturday and Sunday. Please note that holiday hours may vary. For up to date information, please visit www.VIZIO.com.

Products must be returned to the address specified by VIZIO Customer Service and must be shipped in the original packaging, with freight prepaid to VIZIO, and must be received in new and unused condition. The return authorization number must be included in the packaging. VIZIO reserves the right to assess fees for any damaged or missing parts in addition to the ten percent (10%) restocking fee.

Return authorization numbers are valid for only fifteen (15) days from issuance. The customer is responsible for and must prepay all shipping charges and shall assume all risk of loss or damage to the product while in transit to VIZIO. If the product is returned to VIZIO (i) without a VIZIO return authorization number, and/or (ii) beyond the fifteen (15) day period, and/or (iii) without proper packaging, VIZIO retains the right to refuse delivery of such return or may return the unit to the customer at the customer's expense and with no refund issued. This return policy does not apply to defective products. Please read VIZIO's Limited Product Warranty for warranty terms and conditions.

ON-SITE WARRANTY

REPAIR PROCEDURE

On-Site Warranty Repair generally is performed on repairable displays which are 30 inches and larger.

If VIZIO Technical Support determines that a problem with a display unit may be within the terms and conditions of the VIZIO Limited Product Warranty and that an on-site repair may be performed, the customer will be provided with an on-site repair authorization number and on-site repair instructions. The determination for performing the on-site repair may be dependent upon the manufacturing defect and is at VIZIO's option and sole discretion. Proof of purchase is required to confirm the product is within the one-year limited warranty period and meets the terms and conditions of the VIZIO Limited Product Warranty.

On-site repair service is requested through VIZIO's third-party service provider. After VIZIO provides the customer with the on-site repair (OSR) authorization number, the third-party service provider will contact the customer and will schedule the repair at the customer's location. The total approximate time for the repair process, which includes the repair diagnosis, dispatching the technician, shipping the replacement part(s), and arranging the appointment with the customer, is completed within approximately 3 to 5 business days, pending availability of these factors.

If it is determined the product can not be repaired on-site, the customer will be required to ship the unit to VIZIO's service center, per the below warranty replacement procedure.

VIZIO is not responsible for the de-installation or re-installation of the product. However, some standard installation may be performed during the on-site repair, at VIZIO's option and sole discretion. Please read VIZIO's Limited Product Warranty for warranty terms and conditions.

WARRANTY REPLACEMENT PROCEDURE

Warranty Replacement generally is performed on displays which are determined to be economically unrepairable.

If VIZIO Technical Support determines that a problem with a display unit may be within the terms and conditions of the VIZIO Limited Product Warranty and that a repair is not economically possible, based on certain manufacturing defects in materials and/or workmanship, and/or at VIZIO's option and sole discretion, the customer will be provided with a return authorization number and replacement instructions. Proof of purchase is required to confirm the product is within the one-year limited warranty period and meets the terms and conditions of the VIZIO Limited Product Warranty.



For displays forty-two inches (42") and larger, VIZIO will generally cover the transportation charges to perform an on-site swap of the original unit with the replacement unit. For displays under forty-two inches (42"), the customer is responsible for the transportation charges to VIZIO's service center. VIZIO will be responsible for the return transportation charges from the service center to the customer. Please read VIZIO's Limited Product Warranty for warranty terms and conditions.

MAIL-IN WARRANTY REPAIR PROCEDURE

Mail-In Warranty Repair generally is performed on displays which are smaller than 30 inches.

If VIZIO Technical Support determines that a problem with a display unit may be within the terms and conditions of the VIZIO Limited Product Warranty and that a mail-in repair may be performed, the customer will be provided with a return authorization number and mail-in repair instructions. Proof of purchase is required to confirm the product is within the one-year limited warranty period and meets the terms and conditions of the VIZIO Limited Product Warranty.

The customer will be provided with instructions for packing and shipping the unit to the VIZIO service center. The original carton box and packing material, or an equivalent as designated by VIZIO, must be utilized. The cost of shipping to VIZIO's service center is at the customer's expense. After the product is repaired and tested, the VIZIO service center will ship the unit back to the customer at VIZIO's expense. VIZIO is not responsible for the de-installation or re-installation of the product. Please read VIZIO's Limited Product Warranty for warranty terms and conditions.

PLEASE DO NOT RETURN YOUR UNIT TO VIZIO WITHOUT PRIOR AUTHORIZATION.



Component Program Codes

Setup Codes for VCRs	
ABS	458
Admiral	543 549 553 569
Adventura	452 459
Aiko	551 554
Aiwa	452 459 460 536 539 552 571 578
Akai	442 457 570
Alienware	458
America Action	551 567
American High	449 538 555
Amoisonic	552
Anam	539 548 550 551
Anam National	548
Asha	445 550 560
Audio Dynamics	443 579
Audiovox	446 460 539 551 567
Bang & Olufsen	527
Beaumarck	445 550 560
Bell & Howell	444
Broksonic	451 482 487 526 537 549 552 558 559
Calix	446 460 539
Candle	445 446 447 448
Canon	449 538 555 572
Carver	547 561
CCE	546 551 554 562
Changhong	543 547
CineVision	505

Setup Codes for VCRs	
	445 446 447 448 460 525 539 551
Citizen	554
Colortyme	443
Colt	523 546 562
	445 446 450 460 539 546 550 560
Craig	562
Curtis Mathes	441 443 445 448 449 538 544 548 555 578
Cybernex	445 550 560
CyberPower	458
	447 451 452 505 525 542 551 554
Daewoo	563
Davidson	459
DBX	443 579
Dell	458
Denon	575
DiamondVision	520
Dimensia	441
DIRECTV	574
Durabrand	461 540
Dynatech	452 459
Electrohome	446 460 539
Electroponic	446 460 539
Emerex	576
	446 447 449 451 452 459 460 488
	500 512 515 525 526 538 539 541
	542 549 550 551 552 556 558 559
Emerson	573 577 578

Setup Codes for VCRs	
ESA	470
Fisher	444 450
Fuji	442 449 538 555
Fujitsu	542
	452 459 485 488 500 522 556 578
Funai	452 459
Garrard	452 459
Gateway	458
	441 445 449 524 538 544 550 555 560 569
GE	560 569
General	542
Go Video	495 507 560
	443 446 448 460 539 540 549
Goldstar	443 446 448 460 539 540 549
Gradiente	452 459 578
Haojie	550
Harley Davidson	452 522
Harman/Kardon	443 540 547 561
Harwood	546 562
Headquarter	444
Hewlett Packard	458
Hi-Q	450
	454 457 459 500 522 539 572 575
Hitachi	454 457 459 500 522 539 572 575
Howard Computers	458
HP	458
Hughes Network Systems	574 575
Humax	574
Hush	458
iBUYPOWER	458
Insignia	478 506



Setup Codes for VCRs	
Instant Replay	449 572
JC Penney	443 444 445 446 449 454 579
JCL	449
Jensen	454 457
JVC	443 444 448 457 465 475 476 496 542 545 579
KEC	460 539 551
Kenwood	443 444 448 457 540 545 579
KLH	546 562
Kodak	446 449 460 538 539 555
Kolin	541
LG	446 478 480 506 539 540 542 549 578
Linksys	458
Lloyd's	452 459 522
Logik	546 562
LXI	446 460 539 578
Magnasonic	525 556
Magnavox	449 456 459 461 486 509 512 515 522 534 538 547 555 556 561 572
Magnin	446 524 550 560
Marantz	443 444 448 449 538 547 555 561 579 580
Marta	446 460 539
Matsushita	449 538 548 555
Media Center PC	458
MEI	449 538 555

Setup Codes for VCRs	
Memorex	444 445 446 449 450 452 456 459 460 461 462 487 518 521 538 539 543 548 549 550 552 553 555 560 569 571
MGA	524 541 550 560
MGN Technology	445 550 560
Microsoft	458
Midland	453
Mind	458
Minolta	454 575
Mitsubishi	454 466 541 545 569
Motorola	449 538 543 553 555 569
MTC	445 459 550 560
Multitech	445 452 453 459 546 562 578
NEC	443 444 448 457 538 539 540 543 545 579 580
Newave	539
Nikko	446 460 539
Niveus Media	458
Noblex	445 550 560
Northgate	458
Olympic	572
Olympus	449 538 555
Optimus	446 460 521 539 543 548 553 556 557 569
Orion	462 526 549 552 558 559
Panasonic	449 463 479 481 497 514 521 531

Setup Codes for VCRs	
Penney	538 548 555 557 564 565 572 460 524 538 539 540 550 555 560 575 577
Pentax	454 575
Pentax Research	448
Philco	449 538 552 555 572
Philips	449 488 499 509 534 538 547 555 561 572 574
Philips Magnavox	509
Pilot	446 460 539
Pioneer	454 483 545 572 579
Polaroid	510 519
Polk Audio	547 561
Presidian	488
Profitronic	550 560
Proscan	441 544 572
Protec	546 562
Pulsar	456 461
Pye	485
Qisheng	544
Quarter	444
Quartz	444
Quasar	449 521 531 538 548 555 572
Radio Shack	446 459 522
Radio Shack/Realistic	444 445 446 449 450 452
Radix	446 460 539
Randex	446 460 539
RCA	441 445 449 454 501 503 524 533 538 544 550 560 569 572 575



Setup Codes for VCRs	
	444 445 446 447 449 450 452 459
Realistic	460 538 539 543 553 555 569 578
ReplayTV	564
Ricavision	458
Runco	456 461
Sampo	539 543
	445 447 453 477 491 493 495 508
Samsung	517 528 542 550 560 563 570 574
Sanky	456 461 543 553 569
	457 459 462 484 487 522 526 545
Sansui	549 552 558 579
Sanyo	444 445 450 511 524 550 560
Scott	447 451 541 542 559 563
	444 446 449 450 454 459 460 522 538 539 555 575 578
Sears	
	468 485 502 516 529 543 549 553 569
Sharp	
Shintom	442 546 562
Shogun	445 550 560
Signature 2000	578
Singer	449 546 562
Sonic Blue	564
	442 455 458 459 464 467 471 472
	473 489 492 522 535 538 555 568 576
Sony	

Setup Codes for VCRs	
Stack	458
Stack 9	458
STS	449 575
Superscan	512 515
	449 452 459 488 500 504 512 515
	532 538 541 547 555 556 561 572 578
Sylvania	
	452 459 488 500 522 556 578
Symphonic	
Systemax	458
Tagar Systems	458
Tandy	444
Tashiko	446 539
Tatung	457 542 545
Teac	452 457 459 578
	449 538 548 555 565
Technics	
Teco	538 539 540 543
Teknika	446 449 452 459 460 538 539 555
Thomas	459 522
Tivo	566 568 574 581
TMK	445 550 560 577
	447 454 458 469 474 490 494 498
Toshiba	513 530 541 542 545 563 566 581
Totevision	445 446 460 539 550 560
Touch	458
Unitech	445 550 560
Vector	542 563
Vector Research	443 447 540 579
Victor	443 545 579

Setup Codes for VCRs	
Video Concepts	443 447 542 563 579
Videomagic	460 539
Videosonic	445 550 560
Viewsonic	458
Villain	459
Voodoo	458
	445 446 447 449 450 452 454 459
	538 543 544 546 547 550 553 555 560 561 562 569 575
Wards	
Westinghouse	562
White Westinghouse	500 546 549
XR-1000	449 452 459 538 546 555 562
Yamaha	443 444 448 457 540 579
Zenith	442 456 459 461 470 478 522 526
ZT Group	458

Setup Codes for PVRs	
ABS	410
Alienware	410
AT&T	398
Bang & Olufsen	413
CyberPower	410
Dell	410
	399 400 401 402 405 408 411 414 416 417 418 421 422
DIRECTV	
Dish Network	406 407
Dishpro	406
Echostar	406 407
Expressvu	406
Gateway	410



Setup Codes for PVRs	
GOI	406
Hewlett Packard	410
HNS	405
Howard Computers	410
HP	410
HTS	406
Hughes Network Systems	401 402 405 408 414 416 417 418 421 422
Humax	405 414
Hush	410
IBUYPOWER	410
JVC	406 407 414
Linksys	410
Media Center PC	410
Microsoft	410
Mind	410
Niveus Media	410
Northgate	410
Panasonic	398 420
Philips	402 405 408 414 416 417 418 419
RCA	405 411 414 416
ReplayTV	398 404 412
Samsung	405 416 418
Sonic Blue	398 404 412
Sony	403 409 410 415
Stack 9	410
Systemax	410
Tagar Systems	410
Tivo	401 403 405 409 414 415 416 419 421 422 423
Toshiba	410
Touch	410
UltimateTV	411
Viewsonic	410
Voodoo	410
ZT Group	410

Setup Codes for Cable Converters	
	000 001 002 024 026 046 049 051
ABC	053 159
Adelphia	049
Admiral	160

Setup Codes for Cable Converters	
Americast	031
Antronix	004 005
Archer	005
AT&T	042
Bell & Howell	002
Bell South	031
Cable Vision	038 039
Cabletenna	004
Cableview	003
Citizen	058
Clearmaster	030
ClearMax	030
Colour Voice	007
Comcast	040 061 063
Comtronics	058
Contec	053
Coolmax	030
COX	063
Daeryung	049 160 165 168
Digi	166 167
Director	063 164
Dumont	167
Everquest	027 058
Focus	029
GC Electronics	005 058
GE	000 001
Gehua	164
Gemini	008 027
General Instrument	001 025 028 037 040 063 159 163 164
Goldstar	058 059 162
Hamlin	009 018 035
Hitachi	001
Illico	038
Jasco	027

Setup Codes for Cable Converters	
	001 002 008 010 011 024 025 027 028 037 063 159 161 163 164
Jerrold	160
KNC	160
LG	162
Magnavox	012
Memorex	013 026
Monarch	058
Motorola	028 033 037 042 061 062 063 163 164
Movie Time	014 058
Multi Canal	058
Multitech	030
MultiVision	161
NEC	002
NET Brazil	043
Novavision	049
NSC	014
Pace	044 045 046 047 048 049 051
Panasonic	023 026 034 160
Panther	166 167
Paragon	026
Philips	006 007 012 015 016 017
Pioneer	038 044 045 049 059 060 162
Popular Mechanics	029
Proscan	000 001
Pulsar	026 058
Quasar	026
Radio Shack	027 030
RCA	003 021 023 025
Realistic	005
Recoton	029
Regal	009 018 035
Rembrandt	001
Rogers	038
Runco	026



Setup Codes for Cable Converters	
Samsung	058 059 060 162
	038 042 044 045 046 049 050 051
Scientific Atlanta	052 053 054 055 056 057 160 165
Signal	008 027 058
Signature	001
SL Marx	058
Sony	032 039
Sprucer	023
Standard Component	019 020
Starcom	008 024 027 159
Stargate	008 027 058
Starquest	008 027
Supercable	028 163
Supermax	030
TeleView	058
TIME WARNER	038 041
Timeless	058
Tocom	010 161
Torx	159
Toshiba	026
Trans PX	163
Tristar	030
TS	159
Tusa	008 027
TV86	014
U. S. Electronics	053
Unika	004 005
United Cable	024
Universal	004 005
V2	030
Videotron	038
View Star	012 014
Viewmaster	030
Vision	030

Setup Codes for Cable Converters	
Vortex View	030
Zenith	022 026 031 036
Zentek	029

Setup Codes for Satellite Receivers	
Alphastar	102
CaptiveWorks	137
Chaparral	097
Coolsat	135
Crossdigital	147
	081 082 083 085 086 088 089 094 095 096 104 107 108 109 111 113 114 115 116 118 121 122 123 125 126 127 128 130 131 132 133 156
DIRECTV	
	065 066 067 068 069 070 071 072 073 074 075 076 077 078 079 080 084 087 110 124 149
Dish Network	
Dishpro	087 110 149
Drake	098
	065 084 087 110 117 124 149
Echostar	
Expressvu	087 110 117
Freecom	151
GE	108 132
General Instrument	099 105
GOI	110
GoldStar	151
Goodmans	146
Grothusen	151
Hisense	106
Hitachi	111 150 158
HTS	110
Hughes Network	081 082 089 095 109 115 118 126

Setup Codes for Satellite Receivers	
Systems	131
Humax	138
Ilo	106
Jerrold	105
JVC	065 084 110 124
Kosmos	151
Lenco	151
LG	094 151
Lorraine	151
Magnavox	081 104 157
Memorex	104
Mitsubishi	109 118 141
Motorola	105 112 153
Muratto	151
NEC	152
Next Level	105
Panasonic	107 130 140
Pansat	134
Paysat	104
	081 082 089 104 109 111 123 156
Philips	157
Pioneer	082
Primestar	101
Proscan	086 108 125
Proton	106
Radio Shack	105
	085 089 090 096 108 119 120 121 122 139 142 144
RCA	
Realistic	100
Samsung	081 082 089 127 129 145
Sanyo	148
SatPartner	151
Sharp	143
Silva	151
SKY	153
Sony	083 088 091 092 113 128
Star Choice	105



Setup Codes for Satellite Receivers	
STS	103
Sylvania	064
Tivo	081 082 089
Toshiba	109 111 131 154
Triad	151
UltimateTV	083 085
Uniden	104 155 157
US Digital	106
USDTV	106
Viewsat	136
Voom	105
Zenith	093 114 153

Setup Codes for DVD Players	
Accele Vision	100
Advent	004
Aiwa	312 439
Akai	168 319 320 323
Alco	003
Allegro	028
Alpine	160
Amphion MediaWorks	167
AMW	167
Anaba	029
Apex Digital	015 017 047 054 063 079 090 093 098 114 223 291 366 433
Apple	289
Arrgo	019
Aspire	006
Astar	243
Audiovox	003 058 161 304 305 314 381
Axion	325
Bang & Olufsen	018
Blaupunkt	017 095 287
Blue Parade	013

Setup Codes for DVD Players	
BOSE	174 345 353
BOSS	288
Broksonic	168 259
California Audio Labs	001
CambridgeSoundWorks	382
Changhong	426 433
CineVision	277
Clarion	175
Classic	148 176 375
Coby	005 064 121 137 307 358
Curtis	358
Curtis Mathes	025
CyberHome	019 044 430 431 432 435 436
Cytron	322
Daewoo	077 277 440
Denon	001 051 096 119 131 374
Desay	182
DiamondVision	189 331 341
Disney	016 071
Dual	030
Durabrand	020
DVD2000	010
Eclipse	286
Emerson	000 016 021 177 302 335 376
Enterprise	022
ESA	021 169
Fisher	170
Fun TV	031
Funai	016 021 248 263
Gateway	224 434 437
GE	011 017 060 104
Go Video	054 113 159 224 279 280 282 285
Goldstar	285
GPX	185 358 367

Setup Codes for DVD Players	
Gradiente	001 183
Greenhill	017
Grundig	012
Harman/Kardon	138 361
Hitachi	083 159 196 278 310
Hiteker	015
iLive	393
Ilo	299
Initial	017 299
Insignia	021 072 250 380
Integra	013 023 426
Irradio	231
Jamo	032
JBL	361
Jensen	005
JVC	014 057 065 082 084 120 146 147 153 193 216 217 218 219 256 257 328 372 373
Jwin	033
Kawasaki	003
Kenwood	001 051 128 141 154 155 164 165 309 327
KLH	003 017 078 186
Konka	290
Koss	002 007 087 356
Lasonic	178
Lenoxx	020
Lexicon	034
LG	072 214 233 238 250 296 316 370 394
Liquid Video	007
Liteon	222 224 227 247
Lite-On	437
Loewe	035
Magnavox	000 009 012 016 021 045 061 086 226 252 264 273 299 302 335 349



Setup Codes for DVD Players	
	364
Marantz	012 149 150 162
Memorex	071 081 166 339
Microsoft	011
Mintek	017 161 299
Mitsubishi	010 074 092 099 129
NAD	072 177
Nakamichi	179
Nesa	017
Next Base	024
Nexxtech	184
Nissoho Iwai	031
Norcent	151 171
Onkyo	009 023 097 116 117 362 371 426
Oppo	187 330
Optiview	029
Oritron	002 007
Panasonic	001 009 051 056 110 112 123 142 143 144 195 196 197 237 272 396 297 300 306 333 334 346 347 350 357 385 386 387 388 389 395
Philco	027
Philips	009 012 016 045 061 081 091 102 105 107 127 134 135 157 191 202 231 235 240 273 295 299 317 326 356 360
Pioneer	013 059 075 085 089 094 108 132 133 139 156 192 198 203 204 205 236 260 344 368
Polaroid	167 283 308 321 324 340 433
Polk Audio	012
Portland	036
Presidian	016

Setup Codes for DVD Players	
Prima	326
Princeton	037
Proceed	015
Proscan	011 060 115
Pye	263
Qwestar	002
RCA	003 011 013 017 052 060 067 101 115 130 188 271 276 314 315 338 355
Rio	028
Rotel	014
Sampo	180 427 428
Samsung	001 073 103 136 158 159 190 196 221 225 232 239 251 258 267 269 270 281 282 337 351 354 363 390 397
Sansui	168 261 318
Sanyo	170 246 284 378
Sensory Science	224
Sharp	016 069 080 118 220 241 242 262 275 313 336 383 428
Sharper Image	038 435
Sherwood	384
Shinco	172
Shinsonic	008
Sigma Designs	037
Sonic Blue	026 028
Sony	008 048 049 050 053 055 068 076 088 122 140 163 206 207 208 253 265 268 311 342 343 348 352 391 392
Sungale	181
Superscan	000 335
SVA	039

Setup Codes for DVD Players	
Sylvania	000 016 021 081 234 248 274 292 302 329 335
Symphonic	016 081
Teac	003 161 424 429 438
Technics	001 051
Techwood	173
Terapin	040
Theta Digital	013
Tivo	041
Toshiba	009 045 062 066 070 106 109 126 168 194 199 200 201 209 210 211 212 213 215 228 229 230 245 254 255 266 293 294 298 303 332 377
Tredex	042
Trutech	044
TView	029
Urban Concepts	009
V Inc.	424 425
Venturer	003 379
Vizio	043
Westinghouse	301
Xbox	011
Yamaha	001 012 046 051 111 124 127 145 152 244 273 365 369
Zenith	009 072 125 249 250 285 359 370

Setup Codes for Audio Tuners and Receivers	
ADC	049
Adcom	098 148
Admiral	075
ADS	076
Aiwa	048 114 133 164



Setup Codes for Audio Tuners and Receivers	
Akai	073
Alco	058
Altec Lansing	072
Amphion Media Works	059
AMW	059
Anam	052 074
Apex	191
Arcam	068
Audiophase	163
Audiotronic	053
Audiovox	058 159 211
B & K	150
Bang & Olufsen	156
BOSE	165 174
Boston Acoustics	063
CambridgeSoundWorks	212
Capetronic	049
Carver	048 053
Casio	065
CCE	081
Clarinette	065
Classic	205
Coby	182
Creative	067
Curtis	200
Dell	070
Denon	102 110 111 119 120 121 127 138 139 141 142 143 203 304
Eclipse	153
Emerson	157 206
ESA	077
Fisher	060
Fonmix	304

Setup Codes for Audio Tuners and Receivers	
Glory Horse	069
GPX	192 200
Gradiente	166
Harman/Kardon	048 055 145
Hitachi	060
iLive	224
Inkel	064
Insignia	210
Integra	047
JBL	055 185
Jensen	078
JVC	087 097 104 109 128 198 199
Kenwood	056 090 091 094 101 103 116 122
KLH	058
Koss	057 180
Lenoxx	071
LG	054 195 223 227
Linn	048
Lloyds	065
Magnavox	048 049 053 173 189
Marantz	048 053 152 154
MCS	066
Memorex	079
Mitsubishi	146
Modulaire	065
Nakamichi	045 046
Nexxtech	062
Onkyo	047 089 092 093 112 117 118 186 197
Optimus	049 050 051 052
Oritron	057
Panasonic	115 130 160 169 170 172 175 176 177 181 196 201 215 216 217 218 219 220 228 229 307
Penney	065
Philco	080

Setup Codes for Audio Tuners and Receivers	
Philips	048 053 161 180 184 202
Philips Magnavox	162
Pioneer	049 051 085 088 096 099 129 132 140 168 193
Polaroid	158
Polk Audio	048 151
Proscan	306
Qisheng	305
Quasar	115
Radio Shack	069
RCA	049 051 052 058 155 179 306
Realistic	065
Regent	071
Rio	061
Rotel	149
Samsung	187 221 225 226 230
Sansui	048
Sanyo	060 208
Sharp	147 213
Sharper Image	069
Sherwood	131 214
Silsonic	303
Sonic Blue	061
Sony	082 083 084 086 100 106 107 108 113 124 125 167 171 178 188 222 231
Soundesign	050
Stereophonies	051
Sunfire	056
Symphonic	075
Teac	052 058
Technics	105 115 307
Thorens	053
Toshiba	204 207



Setup Codes for Audio Tuners and Receivers	
Venturer	058 209
Victor	087
Wards	048 140
Yamaha	047 095 123 126 134 135 136 137 144 190 194 303
Yorx	065
Zenith	054 183 195

Setup Codes for Audio Amplifiers	
Accuphase	010
Acurus	011
Adcom	034
Angstrom	012
Aragon	011
Audio Source	013
Bel Canto Design	014
Biamp	015
BOSE	003
California Audio Labs	006
Cary Audio Design	009
Chase Technologies	007
Cinema Sound	016
Classe	017
Curtis Mathes	001
Denon	035 036
Digital Audio Control	008
Durabrand	018
Elan	019
Fosgate	020
GE	000

Setup Codes for Audio Amplifiers	
Harman/Kardon	004
JBL	030
JVC	002
Knoll Systems	021
Krell	037
Left Coast	004
Logitech	022
Luxman	023
Marantz	004 041
Mark Levinson	024
McIntosh	025 040
Midland	026
Nakamichi	308
NEC	005
Nikko	027
Onkyo	033
Optimus	001
Parasound	042
Philips	004
Pioneer	001 031
Polk Audio	004
RCA	001
Realistic	309
Sansui	309
Shure	005
Sony	029 044
Soundesign	000
Soundmatters	043
Soundstream	028
Victor	002
Wards	000
Yamaha	032 038 039

Setup Codes for TVs	
888	517
Abex	019
Acer	376
Acura	511

Setup Codes for TVs	
Addison	497
Admiral	002 020 032 038 498
Advent	041 045
Adventura	021
Adyson	508 509
Agashi	508
Aiko	009 497 508 511
Aiwa	190 194 451 491
Akai	003 029 042 044 076 077 078 079 080 081 082 083 084 428 457 493 507 508 511
Alaron	508
Alba	508 511
Albatron	024 025 524
Alleron	012
America Action	035
Amplivision	509
Amstrad	511
Amtron	011
Anam	035 504 511 524
Anam National	004 011 504
Anglo	511
Anhua	494 512
Anitech	511
Ansonic	511
AOC	005 006 029 071 082 083 084 298 329 493 496 497 498 502 505
Aolinpiya	517
Aolinpu	515
Apex Digital	033 040 046 139 172 249 276 432 526



Setup Codes for TVs	
Arcam	508 509
Astar	330
Astra	511
Asuka	508
Atlantic	508
Atori	511
Audiosonic	511
Audiovox	011 035 037 274 290 310 328 442 448 497 505
Aventura	034
Awa	508
Axion	453
Baihua	516 517
Baile	506 513 516
Bang & Olufsen	049
BaoHuaShi	517
Baosheng	514 516
Basic Line	511
Baysonic	035
Beijing	506 513 514 516 517 518
Belcor	329
Bell & Howell	002 013 521
Beng	026 314 331
Binatone	509
Boots	509
Bradford	011 035
Britannia	508
Brockwood	329
Broksonic	035 038 081 084 151 428 484 503
Bush	511
byd:sign	220
Caihong	514 516
Cailing	515 526
Candle	006 007 021 029 082 083 084 329 493

Setup Codes for TVs	
Carnivale	029 082 083 493
Carver	031 527
Cascade	511
CCE	051 217 509
Celebrity	003 492
Celera	040
ChangCheng	494 506 512 513 514 516 517 518
Changfei	514 516
Changfeng	514 517
Changhai	514 516
Changhong	040 501 514 516 518
Chengdu	514
Ching Tai	497
Chun Yun	025 035 492 497 524
Chunfeng	516 517
Chung Hsin	035 495
Chunsun	514 516
Cimline	511
Cinema	507
Citizen	006 007 009 011 017 018 029 042 082 083 329 483 493 496 497
City	511
Clarion	035
Classic	084
Clatronic	511
CME	509
CMS	508
Coby	446
Colortyme	006 082 329
Colt	480
Commercial Solutions	030 525
Concerto	006 329
Concorde	511
Condor	508

Setup Codes for TVs	
Conrowa	499 501 516 517
Contec	035 508 511
Contec/Cony	008 011
Cosmel	511
Craig	011 035
Crosley	031 527
Crown	011 015 035 511
CS Electronics	508
CTX	209
Curtis	084
Curtis Mathes	001 006 013 017 018 029 030 031 032 037 042 043 044 080 082 083 329 493 496 498 499 505 520 521 527
CXC	011 035
Cytron	214 459
Daewoo	005 006 009 018 037 071 084 094 116 124 250 329 358 421 483 493 497 502 505 506 507 508 511 524
Dainichi	508
Dansai	508
Daytron	006 018 329 511
Dayu	506 513
Dell	086 320
Denon	043 053 499
Diamond	508
DiamondVision	221 467 477
Dimensia	001
Dixi	511



Setup Codes for TVs	
DongBao	518
DongDa	516 518
Donghai	516
DongHua	518
DTS	511
Dual Tec	509
Dual-Tec	511
Dumont	028 171 329
Durabrand	027 034 035 038 210 502
Dwin	032
Dynatech	509
ELECTRO TECH	511
Electroband	003 492
Electrograph	377
Electrohome	003 004 006 082 084 329
Element	334
Elin	508
Elite	385
Elta	508 511
	006 008 010 011 012 013 018 023
	034 035 038 082 084 094 321 329
	344 456 468 471 483 484 502 503
Emerson	521
Emprex	338
Envision	006 029 082 083 329 493
Epson	299
ESA	034
Ether	493
Etron	511
Euroman	508
Europhon	508
Feilang	516
Feilu	514 516
Feiyan	517

Setup Codes for TVs	
Feiyue	514 516
Fenner	511
Fidelity	508
FIRST LINE	511
Firstar	503
Firstline	508 509
Fisher	013 163 318 381 509 521
Formenti	508
Formenti/Ph oenix	508
Fortress	082 498
Frontech	511
Fujitsu	012 361 369 370
Funai	011 012 034 035 113 380 479
Furi	499
Futuretech	011 035
Ganxin	514
Gateway	047 377 423
GBC	511
	001 004 006 014 030 037 084 090
	092 108 111 139 329 416 481 493 494 497 502 505 525
GE	
Geloso	511
General Technic	511
Gibraltar	028 029 082 083 171 329 493
GoldHand	508
	005 006 008 018 019 029 061 062
	071 082 083 084 329 482 493 502
Goldstar	508 509 511
Goodmans	509 511

Setup Codes for TVs	
Gradiente	082 218 510
Granada	509
Grandin	511
Grunpy	011 012 035
Haier	027 052
HaiHong	518
Haiyan	514 517
Halhong	516
Halifax	508
Hallmark	006 084 329 502
Hampton	508
Hankook	035 493 502
Hanseatic	511
Hantarex	511
Harley Davidson	479
Harman/Kar don	031 084 527
Harvard	011 035
Havermy	032 498
HCM	511
Helios	374
Hello Kitty	037 505
Hewlett Packard	285 349 365 426
Higashi	508
Hinari	511
Hisense	319 499 501 523 526
	006 008 043 095 101 141 173 181
	186 200 227 279 329 353 360 389
	390 400 411 412 479 493 497 499
Hitachi	501 502 509
Hitch Fufian	514 517
Hongmei	498 514 516 517
Hongyan	514 517
HP	085 285 340 365 426



Setup Codes for TVs	
Huafa	499 516
Huanghaimei	516
Huanghe	514 516
Huanglong	516
Huangshan	514 516 517
Huanyu	508 514 517
Huaqiang	517
Huari	499 517
Huodateji	494 512
Hygashi	508
Hyper	508 511
ICE	508 509 511
ICeS	508
Ilo	326 336 344 455
IMA	011
Imperial Crown	506 513 517
Infinity	015 031 527
InFocus	425
Ingersol	511
Initial	455
Inno Hit	511
Innovation	511
Insignia	210 213 215 222 337
Inteq	028
Interbuy	511
International	508
Intervision	509
Irradio	511
ITS	508
ITT	511
ITV	511
Janeil	021
JBL	015 031 527
JC Penney	001 005 006 007 014 017 018 019 071 084 329
JCB	003 492

Setup Codes for TVs	
Jean	494 497 501 503
Jensen	006 045 082 212 329
Jiahua	494 512
JiaLiCai	516 517 518
Jinfeng	494 512 514
Jinque	514 516 517
Jinta	516 517
Jinxing	499 501 514 517 527
Juhua	514 517
JVC	008 014 143 183 185 187 204 251 263 278 280 406 445 495 510
Kaige	514 516 517
Kaisui	508 509 511
Kamp	508
Kangli	506 513 514 516 517
Kangyi	516 517
KanLi	518
Karcher	511
Kawasho	003 006 329 508
KEC	035
Kenwood	006 029 082 083 084 329 463 493
Kingsley	508
KLH	040 046
Kloss Novabeam	011 021
Kolin	035 495 500
Kongque	514 516 517
Konka	429
Koyoda	511
KTV	011 018 029 035 051 082 083 493 509
Kuaile	516 517
Kunlun	494 506 512 513 514 517

Setup Codes for TVs	
Kyoto	508
Lenco	511
Lenoir	511
LG	005 024 056 057 058 059 060 063 064 065 066 071 270 284 438 493 496 502 508 511 524
Life	511
Lifetec	511
Lihua	514
Lloyd's	479
Loewe	015
Logik	002
Longjiang	514 517
Luxman	006 329
LXI	001 006 013 015 030 031 033 084 501 502 521 527
M Electronic	509 511
Magnafon	508
Magnasonic	082 084 483 006 007 015 029 031 082 083 084 114 128 130 134 162 175 179 256 298 324 329 379 404 435 455 465 468 479 489 493 527
Magnavox	527
Magnin	481
Magnum	511
Majestic	002
Manesth	509
Marantz	006 015 029 031 082 083 307 329 378 382 493 527



Setup Codes for TVs	
Mark	508
Matsui	509 511
Matsushita	036 504
Maxent	324 377
Media Center	085
Medion	511
Megapower	024 524
Megatron	006 043 499 502
Meile	514 517
M-Electronic	508
	002 005 006 013 036 038 071 084
	113 180 475 478 482 500 502 511
Memorex	521 528
Memphis	511
	005 006 029 071 082 083 329 481
MGA	493 500 502
Micromaxx	511
Microstar	511
	014 018 019 028 030 171 494
Midland	
Mintek	455
	005 006 032 071 082 084 129 153
	228 233 329 371 388 396 403 405
Mitsubishi	407 493 498 500 502 503 504
Mivar	508
Monivision	024 025 524
Montgomery Ward	002
Motorola	004 020 032 498

Setup Codes for TVs	
	005 006 017 029 042 071 082 083 084 329 493 496 508
MTC	
MuDan	494 512 514 516 517
Multitech	011 035 051 508 509 511
Multivision	016
Murphy	508
	006 022 033 501 502
NAD	
Nanbao	516 517
Nansheng	514 517
National	494 522
	004 005 006 029 071 082 083 309
NEC	
	329 378 493 494 495 501 502
Net-TV	315 377
New Tech	511
Newave	497 498 502
Nicamagic	508
Nikkai	508
	006 009 029 082 083 493 497 502
Nikko	
Noblisko	508
Norcent	039 298 526
NTC	009 497
Nyon	084
	048 223 224 275 300
Olevia	
Onwa	011 035
Oppo	466
	022 036 478 504 520 521 528
Optimus	
Optoma	427
Optonica	020 032 498 519
	010 023 038 210 484 503 511
Orion	
Osaki	509

Setup Codes for TVs	
Otto Versand	509
Pael	508
Panama	508 509 511
	004 014 015 036 091 107 126 136
	145 182 202 229 232 234 235 237
	238 243 260 261 272 345 346 351
	352 399 401 408 414 436 439 444
Panasonic	
	470 478 494 504 522 527 528
Panda	494 512 514 516 517
Pathe Cinema	508
Pausa	511
	029 030 033 042 082 083 481 482 493 494 496 501 502
Penney	
Perdio	508
	004 005 006 007 008 015 029 031
	071 082 083 084 180 329 493 502 527
Philco	
	004 007 008 015 031 093 115 125
	128 131 144 149 150 160 164 165
	166 169 177 178 179 189 196 199
	203 205 208 236 241 242 244 268



Setup Codes for TVs	
	286 291 313 329 344 350 418 437 455 489 492 493 494 497 502 527
Philips Magnavox	115 125 128 131 134 144 164 175 179
Phoenix	508
Phonola	508
Pilot	018 029 082 083 329 493
	006 022 089 098 226 230 240 329 347 348 360 366 368 384 385 394
Pioneer	520
Plasmsync	378
	040 296 305 310 311 312 334 335 341 343 447 458 460 476
Polaroid	
Poppy	511
	005 006 009 018 071 084 329 497
Portland	
Price Club	017
	045 216 219 462
Prima	511
Princeton	024 524
Prism	014 494
Profex	511
Proscan	001 030 416 525
Prosonic	508 522
Protech	509 511
	006 008 082 084 329 493 502
Proton	
Protron	283 332
Proview	072 335
Pulsar	028 084 171 329
Pymi	511

Setup Codes for TVs	
Qingdao	512 514 517
	004 014 036 126 202 414 478 494
Quasar	504
	013 029 030 035 082 083 479 493
Radio Shack	502 521
	001 006 008 011 013 018 019 329
Radio Shack/Realistic	519
	001 004 005 006 030 071 087 092 096 100 108 116 122 188 195 197
	201 225 246 322 329 373 386 416
	453 474 481 488 492 493 497 502
RCA	525
	013 029 035 082 083 493 502 521
Realistic	
Rhapsody	508
Roadstar	511
Rowa	508 526
	028 029 082 083 171 493
Runco	
Ruyi	514
Saige	514 516
Saisho	511
	006 018 019 029 082 083 211 252
	316 329 377 493 497 498 502 524
Sampo	
	005 006 008 017 018 019 029 042
Samsung	
	044 051 071 080 082 083 084 121

Setup Codes for TVs	
	133 137 140 159 168 174 184 207 239 262 266 269 292 293 303 304
	308 323 329 354 359 364 393 402 454 485 493 496 497 501 502 508 509 511
Sandra	508
Sanjian	517
	023 038 097 210 428 450 461 479
Sansui	484
	013 154 163 318 329 381 481 499
Sanyo	501 508 521
Sanyuan	498 514 516
Sceptre	342
Scotch	006 502
	006 008 010 011 012 035 327 329
Scott	502 503
	001 006 012 013 030 031 033 034
	084 254 329 479 482 501 502 521
Sears	527
SEG	508 509
Semivox	035
Sencora	511
Serino	508
Shancha	514 517
Shanghai	514 516 517
Shaofeng	499 514
	006 008 018 020 032 088 105 117
Sharp	



Setup Codes for TVs	
	142 147 157 191 193 198 247 253
	257 258 259 264 265 267 277 281
	284 295 306 329 333 422 424 452
	473 493 498 519
Shen Ying	497
Shencai	499 516 517
Sheng Chia	032 498 503
ShengCai	518
Shenyang	514 516 517
Sherwood	516
Shogun	329
Signature	002
Silva	508
Silver	082 084
Simpson	007 082 084
Skygiant	035
Skyworth	526
Skyworth-- RGB	514 517
Songbai	516
SongRi	518
Sonoko	511
	003 075 106 138 152 156 167 231
	248 255 271 282 288 355 356 357
	362 392 395 397 398 410 415 420 449 479 490 492 511
Sony	511
Soundesign	006 007 011 012 035 084 329 502
Sowa	494 496 497 501 502
Squareview	034

Setup Codes for TVs	
SSS	011 035 082 329
Standard	509 511
Starlite	011 035
Studio Experience	025
Sunkai	511
Sunwood	511
Superla	508
Superscan	032 073 468 471
SuperTech	508
Supra	511
Supre-Macy	021
Supreme	003 492
Sutron	511
SVA	052 374 526
Sydney	508
	006 007 015 029 031 034 082 083
	084 113 131 321 329 380 435 464 468 471 472 487 493 527
Sylvania	493 527
Symphonic	011 034 035 113 479
Synco	492 496 497 498 502 505
Syntax	275
Syntax- Brilliant	254 275
Sytong	508
Tacico	497 502
Taishan	514 516
Tandy	020 032 498 509
Tashiko	497 508 509
	004 047 325 383 494 496 501 509
Tatung	527
TCM	511
Tec	509 511

Setup Codes for TVs	
Technics	014 036 494 504
Techwood	006 014 082 329 494
Teco	054 494 497 498 502
	002 005 006 007 008 009 011 012
	017 018 031 035 042 071 329 496
Teknika	497 500 527
Telefunken	044 080
Teletech	511
Teleton	509
Televideon	508
Tensai	511
Tera	055 493
Tevion	511
Texet	508
Thomas	479
Tiane	498 514
TMK	006 082 084 329 502
TNCi	028
Tobo	516 517 526
Tokyo	508
Tongguang	517
	013 017 033 042 099 102 103 104
	109 110 112 118 120 123 127 135
	146 155 158 170 176 206 297 302
	351 378 387 391 409 413 417 428
	430 431 433 434 440 443 469 486
Toshiba	496 499 501 521



Setup Codes for TVs	
Totevision	018
Transtec	508
Trutech	317
Tuntex	493 497
TVS	038
Ultravox	508
Vector Research	029 082 083 493
Vexa	511
Victor	008 014 495 504 510
VIDEOLOGIC	508
Videologique	508
VideoTechnic	508 509
Vidikron	031 527
Vidtech	005 006 071 329 502
Viewsonic	050 067 068 069 070 073 074 075 324 377
Viking	021
Viore	326
Visiola	508
Vizio	000 047 050 067 329 331 339
Waltham	509
Wards	001 002 005 006 012 015 029 031 071 082 083 084 329 493 502 519 527
Warumaia	506 513
Watt Radio	508
Waycon	033 501
Weipai	516
Westinghouse	037 050 067 273 287 294 441

Setup Codes for TVs	
White Westinghouse	038 084 094 508
Xiahua	514 516 517
Xiangyang	517
Xiangyu	516
Xihu	514 517
Xinaghai	516 517
Xingfu	516
Yamaha	005 006 029 071 082 083 329 493
Yapshe	504
YingGe	516 518
Yoko	508 509 511
Yonggu	516
Youlanasi	514
Yousida	516
Yuhang	516
Zenith	002 028 038 119 132 148 161 171 192 245 289 301 329 363 367 372 375 400 419 479 484 497 502
Zhuhai	516

