

RYOBI®

**LAWN
EDGER**

MODEL LE720r

**OPERATOR'S
M A N U A L**

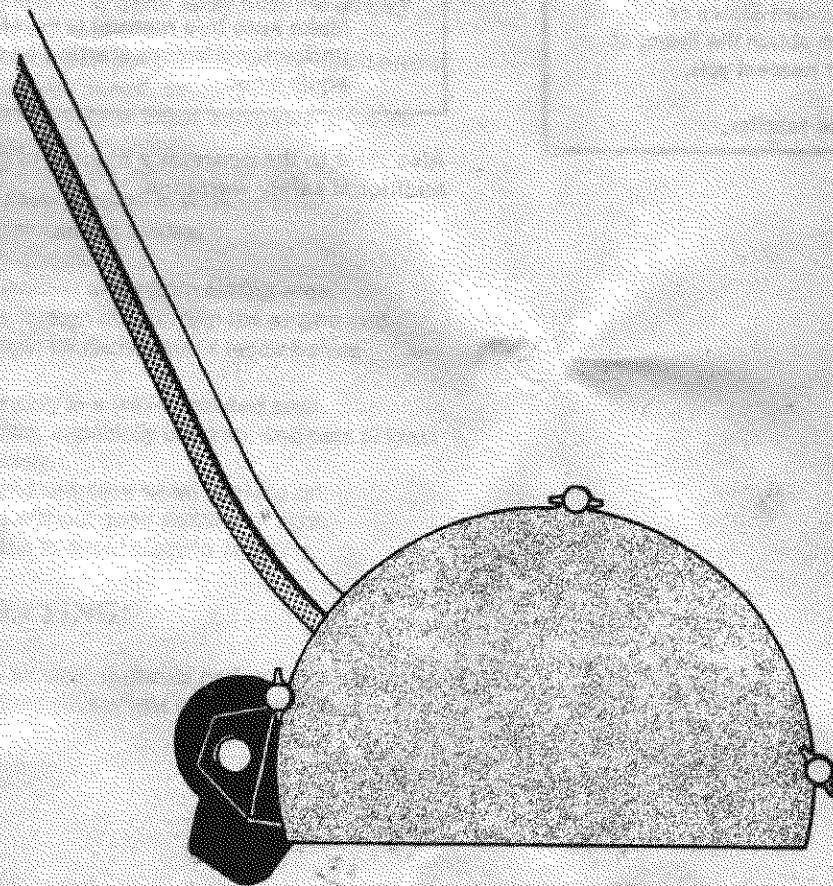

IMPORTANT MANUAL

DO NOT THROW AWAY

INTRODUCTION

THANK YOU

Thank you for purchasing this quality product. This modern outdoor power tool is designed to provide you with many hours of useful service. You will find it to be a great labor-saving device.

This manual provides you with easy-to-understand operating instructions. Read the entire manual and follow all of the maintenance and service procedures to keep your new outdoor power tool in top operating condition.

PRODUCT REFERENCES, ILLUSTRATIONS AND SPECIFICATIONS

All information, illustrations and specifications in this manual are based on the latest product information available at the time of printing. We reserve the right to make changes at any time without notice.

SERVICE INFORMATION

Service on this unit both within and after the warranty period should be performed only by an authorized and approved service dealer.

Dial 1-800-345-8746 in the United States or 1-800-265-6778 in Canada to obtain the listing of the authorized service dealer nearest you.

Do not return the unit to the retailer.

SAFETY WARNINGS

THE PURPOSE OF SAFETY SYMBOLS IS TO ATTRACT YOUR ATTENTION TO POSSIBLE DANGERS. THE SAFETY SYMBOLS, AND THE EXPLANATIONS WITH THEM, DESERVE YOUR CAREFUL ATTENTION AND UNDERSTANDING. THE SAFETY WARNINGS DO NOT BY THEMSELVES ELIMINATE ANY DANGER. THE INSTRUCTIONS OR WARNINGS THEY GIVE ARE NOT SUBSTITUTES FOR PROPER ACCIDENT PREVENTION MEASURES.

SYMBOL	MEANING
	WARNING: Failure to obey a safety warning can result in injury to yourself and others.
	NOTE: Advises you of information or instructions vital to the operation or maintenance of the equipment.



WARNING

Always follow the safety precautions to reduce the risk of fire, electric shock and personal injury.

Make sure this manual is carefully read and understood before starting or operating this equipment.

Also refer to the operator's manual of the power unit for additional safety warnings.

SAFETY WARNINGS

IMPORTANT SAFETY INSTRUCTIONS - SAVE THESE INSTRUCTIONS!

BEFORE OPERATION:

- Carefully read and understand the operator's manual of the unit that powers this attachment.
- Inspect the area to be edged before starting the unit. Remove all debris, and hard and sharp objects such as rocks or glass, which may be thrown by the blade.

WHILE OPERATING:

- Always wear safety goggles/glasses at all times when using the unit. They provide protection against flying objects and dust.
- Wear a dust mask if use will create a dust laden environment.
- Dress properly. Avoid wearing clothing with loose strings, chains, ties, etc.
- Keep blade and guard clear of debris.
- Keep clothing and body parts away from the cutting edger blade.
- Do not edge near other people. The edger could propel small objects at high speed, causing injury.
- Never attempt to clear the blade and guard of debris with the engine/motor running.
- Never operate the edger without the blade cover in place and properly secured in working order.
- Stay clear of the rotating blades.
- Maintain blade condition.
- Keep hands and feet away from cutting area.
- After striking a foreign object, stop the engine and inspect the edger for damage and repair before restarting it.
- Use the edger only in a well-ventilated area.
- Keep bystanders, especially children, and pets at least 30 ft (9.1 m) away.
- Look behind and use care when backing up.
- Never operate without good visibility or light.
- Exercise caution to avoid slipping or falling.

AFTER OPERATING:

- Only qualified personnel should perform any repairs or maintenance procedures that are not described in this manual.

SPECIAL SAFETY WARNINGS FOR ELECTRIC TRIMMERS AND LAWN EDGERS

- Do not use in rain.
- Avoid dangerous environments - never operate edger in damp or wet conditions.
- To reduce the risk of electric shock, do not expose the unit to rain or operate unit on wet ground.
- Always unplug the unit and allow it to cool before putting it into storage. Store indoors.
- Always unplug the unit when not in use, and before performing any maintenance or repairs.





SPECIAL SAFETY WARNINGS FOR GAS TRIMMERS AND LAWN EDGERS

- Avoid spilling the fuel when mixing the oil.
- Do not smoke while fueling the power unit.
- Fuel the power unit in a well-ventilated area.
- Move away from the fueling area when starting the unit.
- Do not smoke while operating the unit.
- Store in an area free of potential fuel vapor ignition sources such as open flames (pilot lights) or electrical sparking devices (switches, electric motors).
- Turn off the engine and let it cool before refueling or before putting the unit in storage.

SAFETY WARNINGS (Continued)

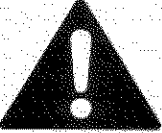
SAFETY AND INTERNATIONAL SYMBOLS

This operator's manual describes safety and international symbols and pictographs that may appear on this product. Read the operator's manual for complete safety, assembly, operating and maintenance and repair information.

SYMBOL	SIGNIFICATION
	<ul style="list-style-type: none">• SAFETY ALERT SYMBOL. Indicates caution, warning, or danger. May be used in conjunction with other symbols or pictographs.
	<ul style="list-style-type: none">• READ OPERATOR'S MANUAL. Failure to follow operating instructions and safety precautions in operator's manual can result in serious injury. Read operator's manual before starting or operating this unit.
	<ul style="list-style-type: none">• WEAR EYE AND HEARING PROTECTION. Warning. Thrown objects and loud noise can cause severe eye injury and hearing loss. Wear ear and eye protection when operating this unit.
	<ul style="list-style-type: none">• FOR SERVICE INFORMATION, CALL: USA: 1-800-345-8746 CANADA: 1-800-265-6778

ASSEMBLY INSTRUCTIONS

Your unit may or may not be completely assembled. If it is not assembled, use the following instructions.

1. Loosen the 2 cover wing screws and swivel cover. Install the carriage bolt through the housing and secure the wheel bracket assembly with the adjustment knob and flat washer. Make sure the carriage bolt is properly seated through the housing (Fig. 1).

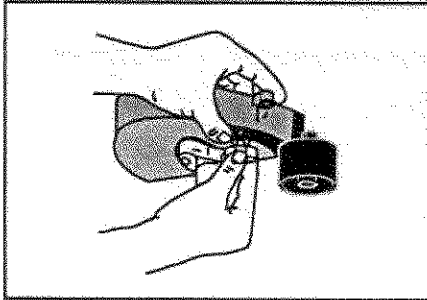

Fig. 1

2. Pull the flex shaft out of the boom about 51 mm (2 in). Insert the shaft into the square hole in the housing (Fig. 2).

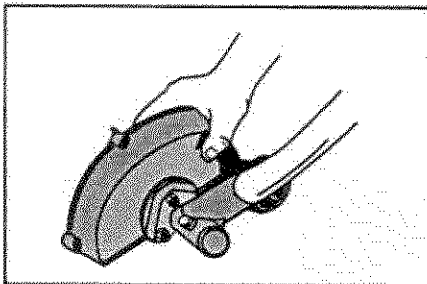

Fig. 2

3. Back out the anti-rotation screw and push the boom assembly into the casting. Rotate until the hole in the boom is aligned with the hole in the casting. Install the anti-rotation screw and tighten the clamp screw (Fig. 3).

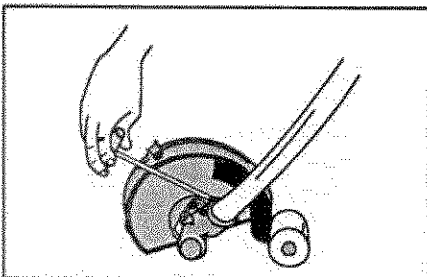

Fig. 3

OPERATING SPLIT BOOM® COUPLER

1. Loosen the wing screws of the Split Boom® coupler. This will allow the lower (attachment) boom to be inserted into the coupler (Fig. 4).

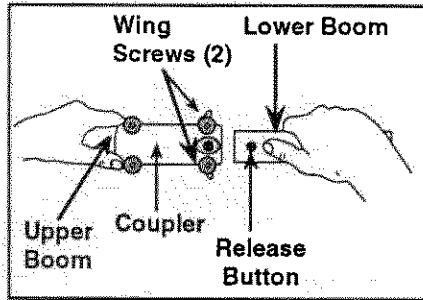

Fig. 4

2. Remove the protective cover from the lower boom and push it into the coupler (Fig 5).
3. Before locking the release button into the coupler, rotate the boom 90 degrees; then rotate the lower boom back 90 degrees. This will ensure the drive shafts in both the upper and lower booms are engaged.

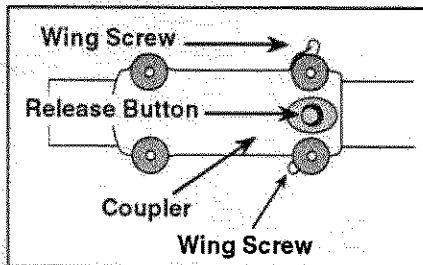

Fig. 5

4. Locate and lock the release button into the hole in the coupler (Fig. 5). Check the sight hole to make sure both ends of the boom are together (Fig. 6). Tighten the wing screws before using.
5. To remove the attachment, loosen the wing screws, push the release button and pull the lower boom straight out of the coupler (Fig. 6).

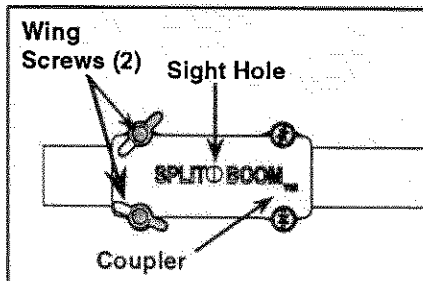

Fig. 6

OPERATING INSTRUCTIONS

1. The edger is designed to cut deep edges along paths, driveways, rockeries, etc. It may be necessary to first dig a small trench along the edge so the blade can rotate at speed. By regularly edging the path, the trench will be maintained and the blade will cut effectively.
2. Do not force the unit into deep overgrown edges because this may cause damage to the blade or drive mechanism.
3. The illustration below shows the typical operating position. Edge along paths, driveways, gardens (Fig. 7).

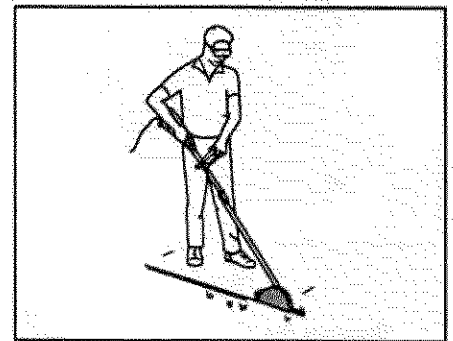

Fig. 7

4. To adjust the blade cutting depth, loosen the adjustment knob above the wheel. Slide the bracket into the desired position and retighten the knob (Fig. 8).

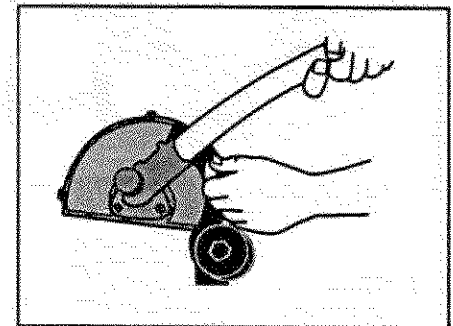

Fig. 8

MAINTENANCE INSTRUCTIONS

BLADE CLEANING/ REPLACEMENT

WARNING

Always wear gloves while installing or handling the blade.

1. To clean or replace the blade, with engine/motor turned off, loosen the 2 wing screws and the swivel cover (Fig. 9).

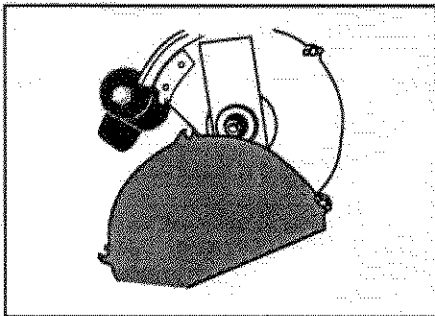

Fig. 9

2. Remove the blade by inserting the locking rod tool into the blade driver slot and loosen the lock nut **clockwise** with a wrench. Remove the nut, retainer washer and blade (Fig. 10).

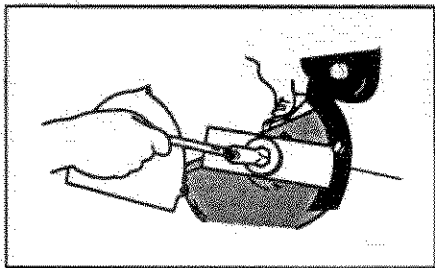

Fig. 10

3. Install the blade, retainer washer and lock nut. Insert the locking rod tool into the slot or blade driver. Proper care should be taken to ensure that the blade stays in its proper position.
4. If you have a torque wrench, tighten the lock nut to 225-250 in•lb (25.3-28.1 N•m), while holding the locking rod in the locking rod slot (Fig. 11).

If you do not have a torque wrench, thread the lock nut onto the brush blade by hand as tightly as possible (Fig. 12). Using an open-ended wrench, rotate the nut 1/4-1/2 of a full turn (Fig. 13). The torque of the nut should be within the required specifications of 225-250 in•lb (25.3-28.1 N•m).

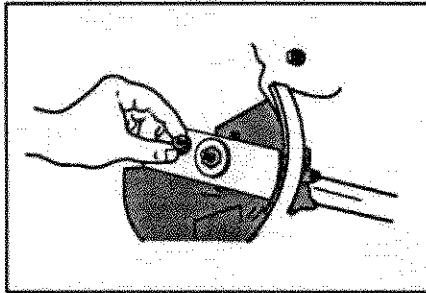

Fig. 11

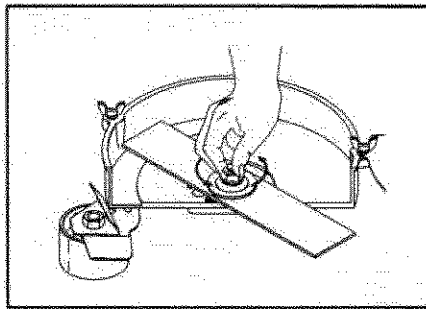

Fig. 12

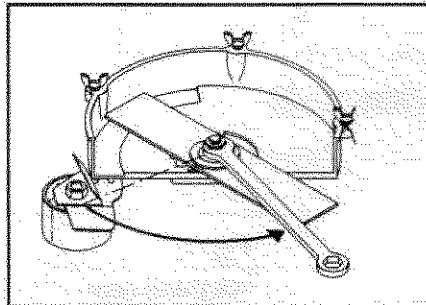

Fig. 13

5. Check the gear housing for lubricant every 50 hours of operation. Remove the grease fill plug to check the lubricant level. It should be up to the bottom edge of check hole. If low, bring up to, but not over, the bottom edge with a good quality, lithium-based, #2, multi-purpose grease. Securely tighten the fill plug to prevent leakage (Fig. 14).

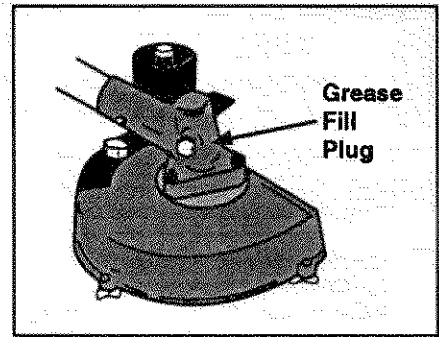

Fig. 14

SPECIFICATIONS

Operating Weight of Attachment:

5.25 lbs. (2.36 kg)

PARTS LIST - MODEL LE720r

Serial no. 407061541 and greater.

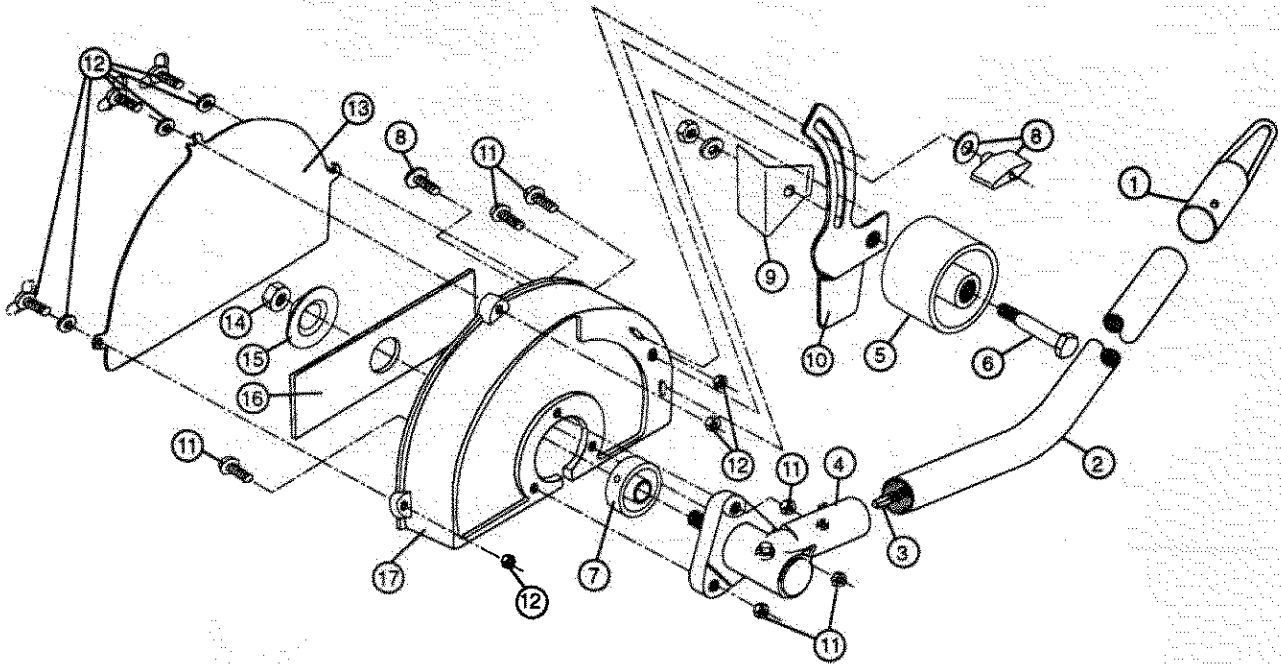

ITEM	PART NO.	PART NAME
1	612605	Hanger
2	180199	Drive Shaft Housing Assembly
3	180198	Drive Shaft Assembly
4	684067	Gear Box Assembly (includes items 7, 14 and 15)
5	613216	Wheel
6	684068	Wheel Mounting Bolt Assembly
7	613217	Driver, Blade
8	684069	Adjustment Knob Assembly
9	613218	Deflector
10	613219	Guide Bracket
11	684070	Mounting Bolt Assembly, Set
12	684071	Mounting Bolt Set, Cover

ITEM	PART NO.	PART NAME
13	180103	Cover
14	613221	Retaining Nut
15	613222	Retaining Washer
16	180064	Blade
17	613224	Guard
*	613226	Locking Rod
*	180014	Blade Retainer Kit (items 14 & 15)
*		not shown

Limited Two-Year Warranty

RYOBI AMERICA CORP. warrants each new RYOBI Product for two (2) years according to the following terms.

This warranty extends to the original retail purchaser only and commences on the date of original retail purchase.

Any part of the RYOBI Product manufactured or supplied by RYOBI and found in the reasonable judgement of RYOBI to be defective in material or workmanship will be repaired or replaced by an authorized RYOBI service dealer without charge for parts and labor.

The RYOBI Product including any defective part must be returned to an authorized service dealer within the warranty period. The expense of delivering the RYOBI Product to the dealer for warranty work and the expense of returning it back to the owner after repair or replacement will be paid for by the owner. RYOBI's responsibility in respect to claims is limited to making the required repairs or replacements and no claim of breach of warranty shall be cause for cancellation or rescission of the contract of sale of any RYOBI Product. Proof of purchase will be required by the dealer to substantiate any warranty claim. All warranty work must be performed by an authorized RYOBI service dealer.

This warranty is limited to ninety (90) days from the date of original retail purchase for any RYOBI Product that is used for rental or commercial purposes, or any other income-producing purpose.

This warranty does not cover any RYOBI Product that has been subject to misuse, neglect, negligence, or accident, or that has been operated in any way contrary to the operating instructions as specified in the RYOBI Operator's Manual. This warranty does not apply to any damage to the RYOBI Product that is the result of improper maintenance or to any RYOBI Product that has been altered or modified so as to adversely affect the products operation, performance or durability or that has been altered or modified so as to change its intended use. The warranty does not extend to repairs made necessary by normal wear or by the use of parts or accessories which are either incompatible with the RYOBI Product or adversely affect its operation, performance or durability.

In addition, this warranty does not cover:

- A. Tune-ups - Spark Plugs, Carburetor Adjustments, Filters
- B. Wear Items - Bump Knobs, Outer Spools, Cutting Line, Inner Reels, Starter Pulley, Starter Ropes.

RYOBI reserves the right to change or improve the design of any RYOBI Product without assuming any obligation to modify any product previously manufactured.

ALL IMPLIED WARRANTIES ARE LIMITED IN DURATION TO THE TWO (2) YEAR WARRANTY PERIOD OR NINETY (90) DAYS FOR PRODUCTS USED FOR ANY COMMERCIAL PURPOSE. ACCORDINGLY, ANY SUCH IMPLIED WARRANTIES INCLUDING MERCHANTABILITY, FITNESS FOR A PARTICULAR PURPOSE, OR OTHERWISE, ARE DISCLAIMED IN THEIR ENTIRETY AFTER THE EXPIRATION OF THE APPROPRIATE TWO-YEAR OR NINETY DAY WARRANTY PERIOD. RYOBI'S OBLIGATION UNDER THIS WARRANTY, IS STRICTLY AND EXCLUSIVELY LIMITED TO THE REPAIR OR REPLACEMENT OF DEFECTIVE PARTS, AND ROP DOES NOT ASSUME OR AUTHORIZE ANYONE TO ASSUME FOR THEM ANY OTHER OBLIGATION. SOME STATES DO NOT ALLOW LIMITATIONS ON HOW LONG AN IMPLIED WARRANTY LASTS, SO THE ABOVE LIMITATION MAY NOT APPLY TO YOU.

RYOBI ASSUMES NO RESPONSIBILITY FOR INCIDENTAL, CONSEQUENTIAL OR OTHER DAMAGES INCLUDING, BUT NOT LIMITED TO EXPENSE OF RETURNING THE RYOBI PRODUCT TO AN AUTHORIZED SERVICE DEALER AND EXPENSE OF DELIVERING IT BACK TO THE OWNER, MECHANIC'S TRAVEL TIME, TELEPHONE OR TELEGRAM CHARGES, RENTAL OF A LIKE PRODUCT DURING THE TIME WARRANTY SERVICE IS BEING PERFORMED, TRAVEL, LOSS OR DAMAGE TO PERSONAL PROPERTY, LOSS OF REVENUE, LOSS OF USE OF THE PRODUCT, LOSS OF TIME, OR INCONVENIENCE. SOME STATES DO NOT ALLOW THE EXCLUSION OR LIMITATION OF INCIDENTAL OR CONSEQUENTIAL DAMAGES, SO THE ABOVE LIMITATION OR EXCLUSION MAY NOT APPLY TO YOU.

This warranty gives you specific legal rights, and you may also have other rights which vary from state to state.

This warranty applies to all RYOBI Products manufactured by RYOBI and sold in the United States and Canada.

To locate your nearest service dealer dial 1-800-345-8746 in the United States or 1-800-265-6778 in Canada.

RYOBI.

RYOBI AMERICA CORP.

5201 Pearman Dairy Rd
Anderson, SC 29622-1207 U.S.A.

RYOBI CANADA INC.

275 Industrial Rd
Cambridge, Ontario N1R 6K2 CANADA

RYOBI®

720r

**PARTS
MANUAL
Manuel
des pièces
MANUAL
DE REPUESTOS**

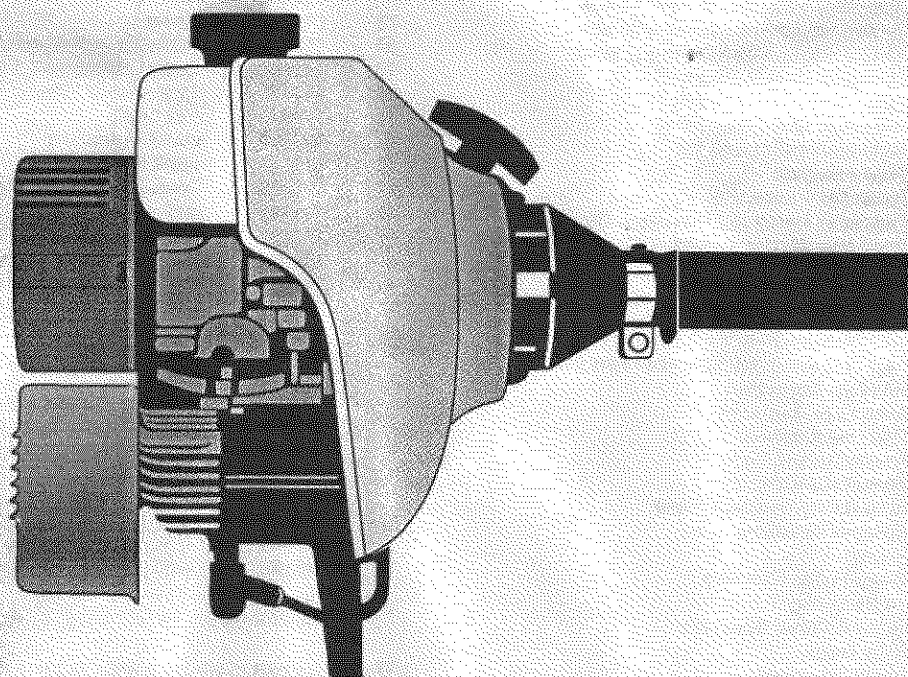

ENGINE PARTS - MODEL 720r

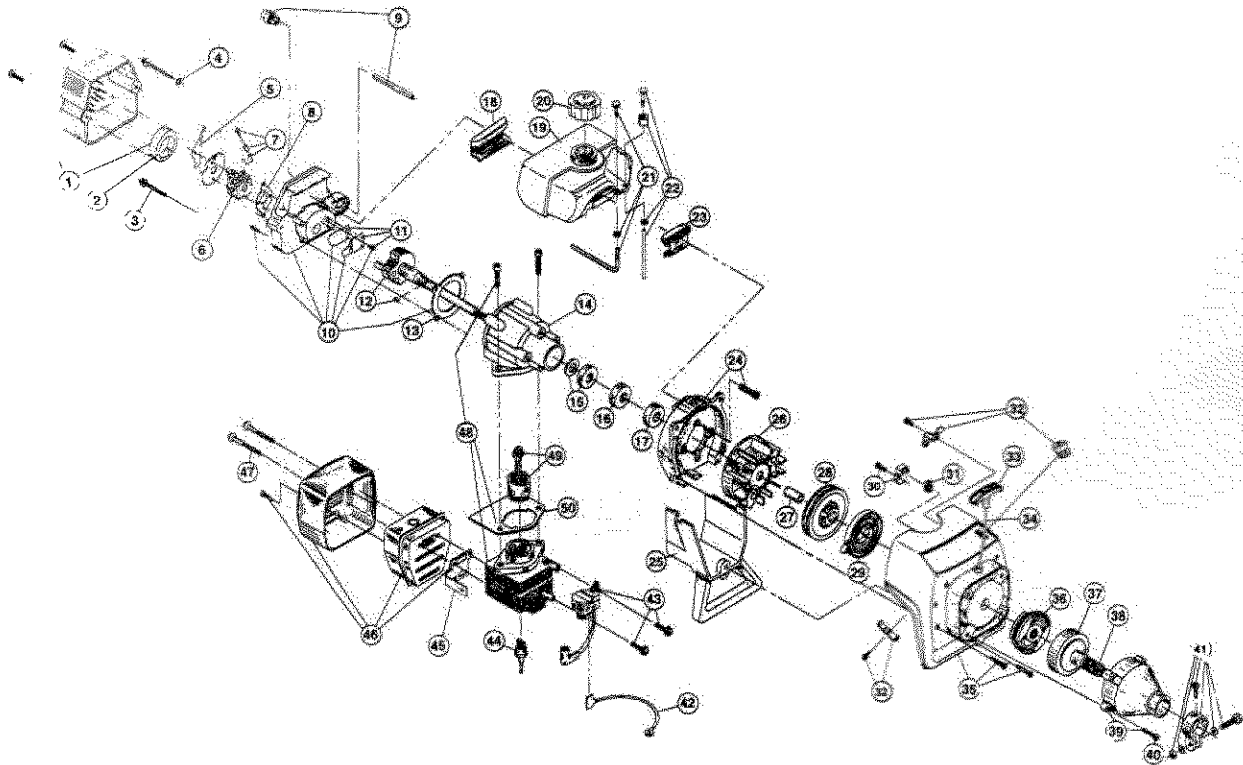

Item	Part No.	Description
1	180349	Carburetor/Air Cleaner Cover Assembly (includes item 2)
2	180350	Air Cleaner Filter
3	180351	Carburetor Mounting Screw Assembly
4	180352	Wavey Washer
5	180353	Choke Lever and Plate
6	180984	Carburetor Assembly W/Limiter Caps
7	682048	Throttle Adjustment Assembly (Walbro)
8	180092	Throttle Adjustment Assembly (Zama)
9	610675	Carburetor Gasket (10 pack)
10	683974	Primer and Hose Assembly
11	180354	Carburetor Mount Assembly (includes items 11 and 13)
12	147573	Reed Assembly
13	180022	Power Shaft Assembly
14	612115	Carburetor Mount Gasket (10 pack)
15	180026	Crankcase Service Assembly (items 12, 14-17)
16	682041	Inner Bearing Assembly
17	610309	Seal
18	610308	Outer Bearing Assembly
19	612134	Rear Mounting Pad
20	147580	Fuel Tank Assembly (includes items 20-22)
21	180000	Fuel Cap Assembly
22	147290	Return Line Assembly
23	682039	Fuel Line Assembly
24	145308	Front Mounting Pad
25	153520	Shroud Assembly
26	683078	Shroud Extension and Stand
27	180929	Flywheel Assembly
28	145918	Spacer
29	180535	Recoil Pulley Assembly
30	613102	Recoil Spring
31	180930	Pulley Retainer Assembly
32	611061	Rope Guide
33	180035	Switch Assembly
34	610300	Pull Handle

Item	Part No.	Description
34	613103	Rope
35	180101	Starter Housing Assembly
36	153591	Clutch Rotor Assembly
37	153592	Clutch Drum Assembly
38	612468	Spring
39	683601	Clutch Cover Assembly
40	145888	Clutch Cover Screw Assembly
41	153597	Upper Clamp Assembly
42	180036	Wire Lead
43	683390	Module Assembly
44	610311	Spark Plug
45	180980	Exhaust Gasket
46	180119	Muffler Assembly
47	147575	Muffler Mounting Bolt Assembly
48	180063	Cylinder Assembly
49	147012	Piston and Rod Assembly
50	610674	Cylinder Gasket (10 pack)
*	180034	Engine Hardware Kit
*	180011	Engine Gasket Kit
*	153308	O.E.M. Carburetor Repair Kit (Walbro)
*	180090	O.E.M. Carburetor Repair Kit (Zama)
*	153309	Gasket-Diaphragm Repair Kit (Walbro)
*	180091	Gasket-Diaphragm Repair Kit (Zama)
*	180530	Piston Ring
*	180027	Short Block Assembly (items 12, 14-17, 48-50)
*	610676	Flywheel Key (10 pack)
*	147544	Starter Housing Screw Set
*	180986	Carburetor Limiter Cap Set
*		not shown

The above part numbers are for serial numbers 503136551 and greater.

BOOM & TRIMMER PARTS - MODEL 720r

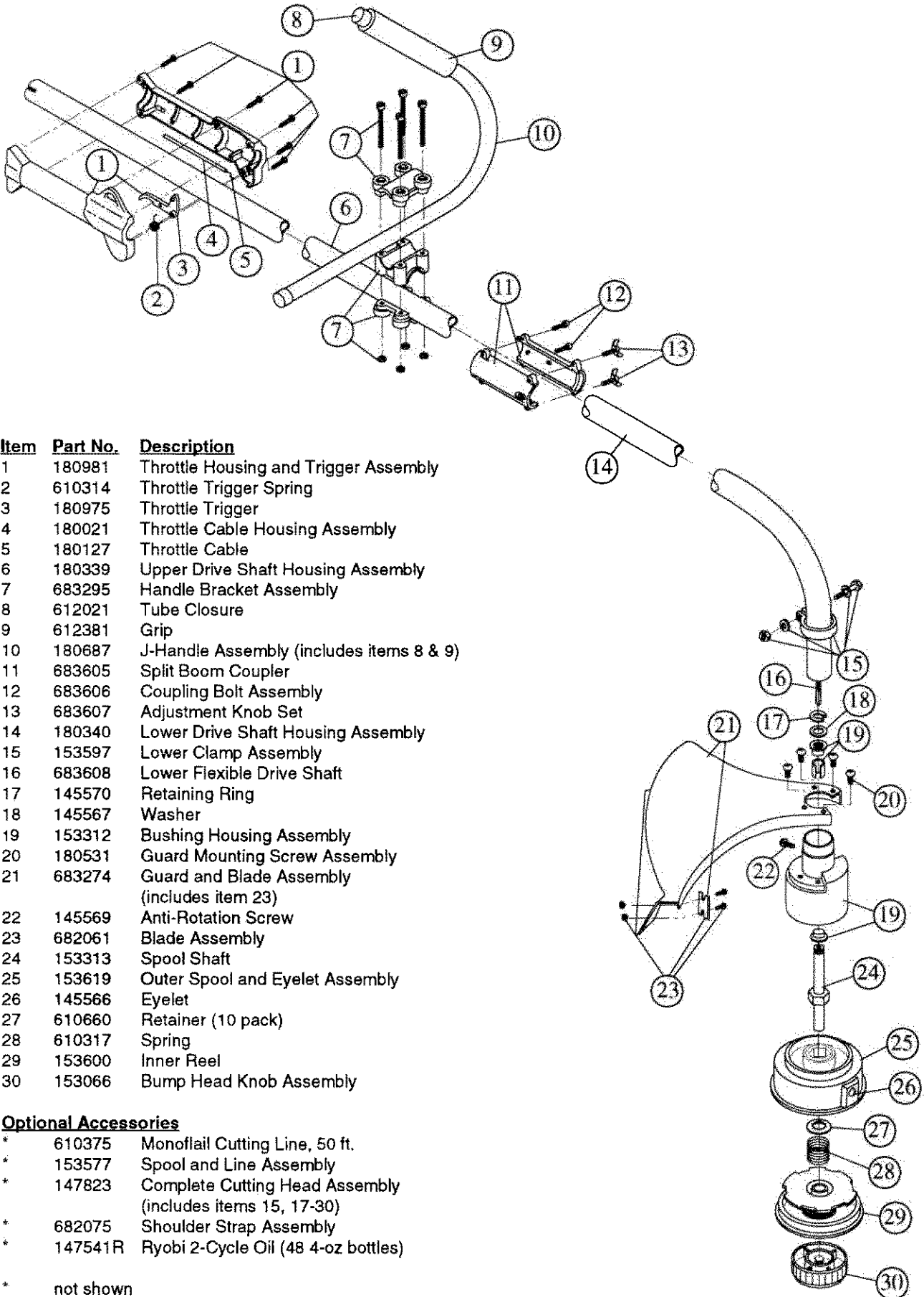

Item	Part No.	Description
1	180981	Throttle Housing and Trigger Assembly
2	610314	Throttle Trigger Spring
3	180975	Throttle Trigger
4	180021	Throttle Cable Housing Assembly
5	180127	Throttle Cable
6	180339	Upper Drive Shaft Housing Assembly
7	683295	Handle Bracket Assembly
8	612021	Tube Closure
9	612381	Grip
10	180687	J-Handle Assembly (includes items 8 & 9)
11	683605	Split Boom Coupler
12	683606	Coupling Bolt Assembly
13	683607	Adjustment Knob Set
14	180340	Lower Drive Shaft Housing Assembly
15	153597	Lower Clamp Assembly
16	683608	Lower Flexible Drive Shaft
17	145570	Retaining Ring
18	145567	Washer
19	153312	Bushing Housing Assembly
20	180531	Guard Mounting Screw Assembly
21	683274	Guard and Blade Assembly (includes item 23)
22	145569	Anti-Rotation Screw
23	682061	Blade Assembly
24	153313	Spool Shaft
25	153619	Outer Spool and Eyelet Assembly
26	145566	Eyelet
27	610660	Retainer (10 pack)
28	610317	Spring
29	153600	Inner Reel
30	153066	Bump Head Knob Assembly

Optional Accessories

- * 610375 Monofilament Cutting Line, 50 ft.
- * 153577 Spool and Line Assembly
- * 147823 Complete Cutting Head Assembly
(includes items 15, 17-30)
- * 682075 Shoulder Strap Assembly
- * 147541R Ryobi 2-Cycle Oil (48 4-oz bottles)
- * not shown

RYOBI®

ELECTRIC AND GAS TRIMMER ACCESSORIES

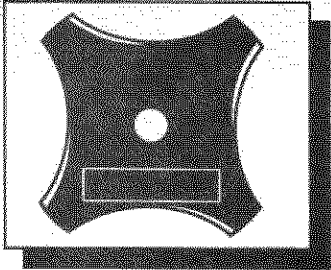

**Replacement
Brushcutter Blade**
Fits 284, 740r, 750r, 780r,
780re, 780rb, 790r, 865r,
885r, 990r

P/N 145873r

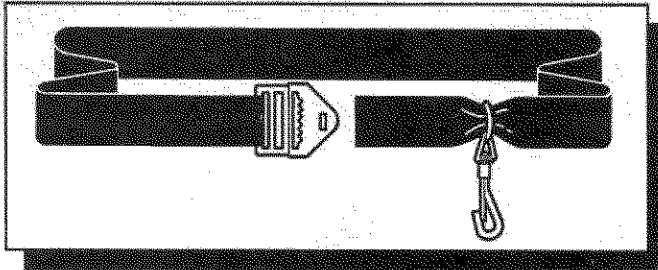

Shoulder Strap Assembly
Fits all gas and electric models

P/N 682075r

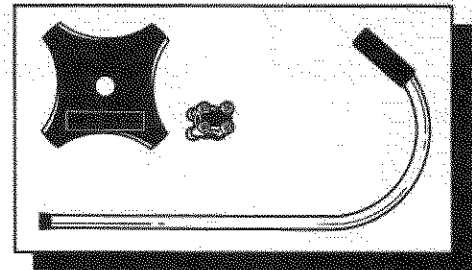

Brushcutter Kit
Includes J-Handle, Blade and
Hardware
For model 865r only

P/N 500795

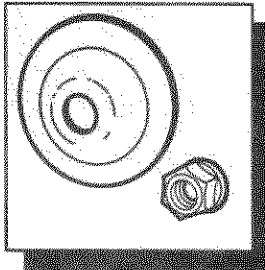

Blade Retaining Kit
Fits LE720, 780r,
780re, 780rb, 790r,
865r, 885r and 990r

P/N 180014r

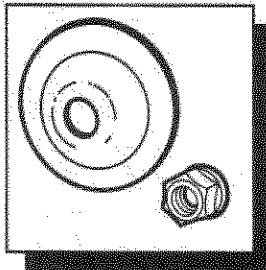

Blade Retaining Kit
Fits 284, 740r, 750r

P/N 180015r

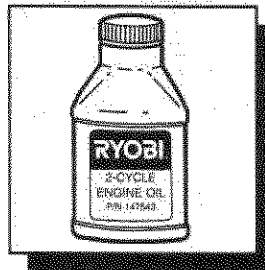

2-Cycle Engine Oil
All 2-cycle models

P/N 147543r

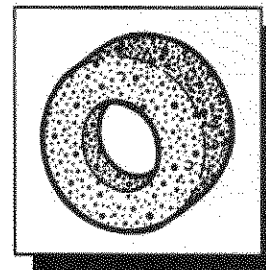

Foam Filter
All gas models except
865r and 885r

P/N 180350r

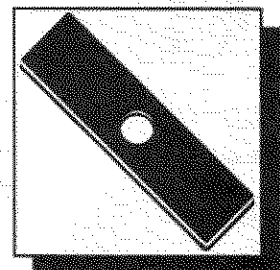

Edger Blade
For LE720r, 720Er
and 780re

P/N 613223r

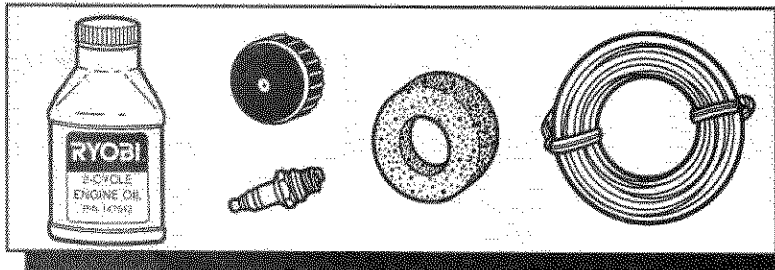

Tune-Up Kit
Fits all 2-cycle models except 780r, 780rb, 780re, 790r, 865r
and 885r

P/N 180062r

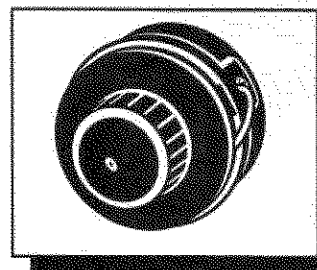

Head Assembly
for 740r and 750r

P/N 153700r

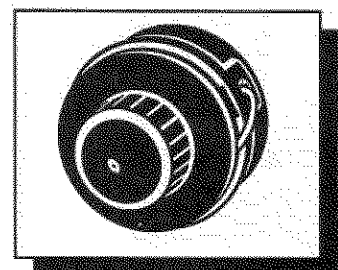

Head Assembly
Fits 130r, 135r, 700r, 710r,
720r, 760r, 765r, 770r,
920r, 960r, 970r, CS720r,
SS720r

P/N 180897r

RYOBI®

RYOBI AMERICA CORP.

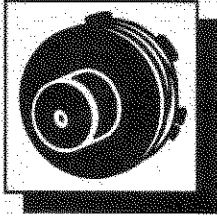

.065 Single Line Cartridge
Fits battery trimmers
140r, 150r.

P/N 180292r

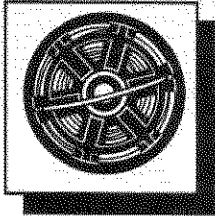

.065 Dual Line Cartridge
Fits electric trimmers
100r and 125r.

P/N 180522r

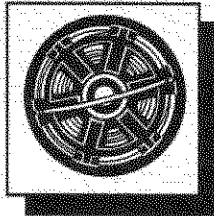

.080 Dual Line Cartridge
Fits 130r, 135r, 700r,
710r, 720r, 740r, 750r,
760r, 765r, 770r, 920r,
960r, 970r, CS720r and
SS720r

P/N 153577r

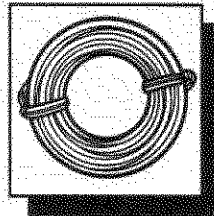

.080 Trimmer Line Loop with 50 feet.
Fits 130r, 135r, 700r,
710r, 720r, 740r, 750r,
760r, 765r, 770r, 920r,
960r, 970r, CS720r and
SS720r

P/N 610375r

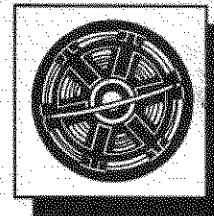

.095 Dual Line Cartridge
Fits 780r, 780rb, 780re,
790r, 865r, 885r and
990r

P/N 147345r

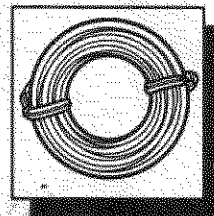

.095 Trimmer Line Loop with 50 ft.
Fits 780r, 780rb, 780re,
790r, 865r, 885r and
990r

P/N 180120r

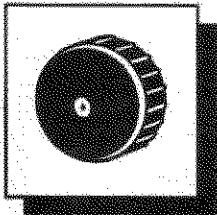

Bump Head Knob Assembly
Fits 100r, 125r, 130r,
135r, 700r, 710r, 720r,
740r, 750r, 760r, 765r,
770r, 920r, 960r and
970r

P/N 153066r

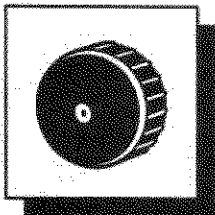

Bump Head Knob Assembly (Large)
Fits 780r, 790r, 865r,
885r and 990r

P/N 180814r

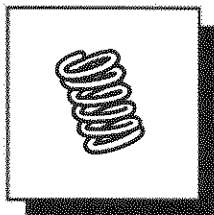

Inner Reel Spring
Fits 100r, 125r, 130r,
135r, 700r, 710r, 720r,
740r, 750r, 760r, 765r,
770r, 920r, 960r and
970r

P/N 610317r

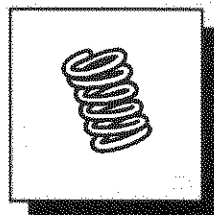

Inner Reel Spring
Fits 780r, 780rb, 780re,
790r, 865r, 885r, 990r

P/N 610636r

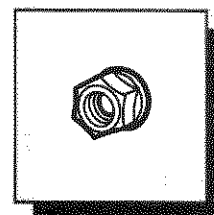

Blade Retaining Nut
Fits LE720r, 780r,
780rb, 780re, 790r,
865r, 885r and 990r

P/N 147491r

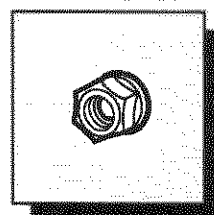

Blade Retaining Nut
Fits 284, 740r and 750r

P/N 145895r

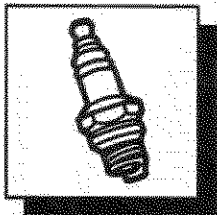

Spark Plug
Fits all 2-cycle gas
models except 865r and
885r

P/N 610311r

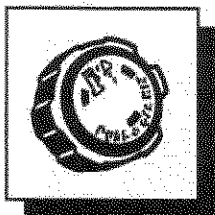

Fuel Cap Assembly
Fits all gas models.

P/N 180000r

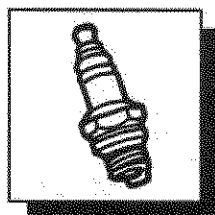

Spark Plug
Fits all 4-cycle gas
models.

P/N 180852r

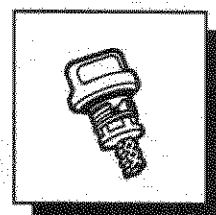

Oil Plug
Fits all 4-cycle gas
models

P/N 181022r

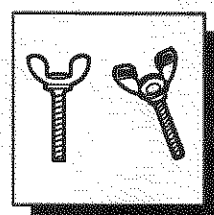

Wing Screws
Fit all TrimmerPlus
models.

P/N 683607r

IF YOU ARE UNABLE TO FIND RYOBI BRAND ACCESSORIES AT YOUR LOCAL RETAILER, CALL THE RYOBI FACTORY SERVICE CENTER NEAREST YOU OR CALL 1-800-345-8746 FOR FURTHER INFORMATION

CALIFORNIA:
FLORIDA:
GEORGIA:

1-800-597-9624
1-800-345-4889
1-800-447-2192

ILLINOIS:
MASS.:
MINNESOTA:

1-800-310-2581
1-800-717-3657
1-800-276-0801

NEW JERSEY:
TEXAS:
WASHINGTON:

1-800-847-5993
1-800-345-7880
1-800-807-8898

RYOBI.

National Parts Distributor Network Réseau Des Distributeurs Nationaux De Pièces Red Nacional De Distribuidores De Repuestos



- | | | | |
|---|---|---|---|
| 1. SPENCER of JACKSONVILLE
Jacksonville, FL
(800) 330-2775 (N)
(904) 262-5667 | 8. GARDNER ENGINES
Columbus, OH
(800) 848-8946 (N)
(614) 488-7951 | 15. MEDART MEMPHIS, INC.
Memphis, TN
(800) 765-4365 (N)
(901) 795-4365 | 22. RYOBI FACTORY SVC CTR
Newton, MA
(800) 717-3657 (N)
(617) 630-2703 |
| 2. AUTO ELECTRIC CO. of AL, INC.
Dothan, AL
(800) 476-4143 (N)
(205) 792-4144 / 792-4143 | 9. GARDNER EAST
S. Brunswick, NJ
(800) 336-6290 (N)
(609) 860-8060 | 16. MEDART TULSA
Tulsa, OK
(800) 999-6426 (N)
(918) 627-1448 | 23. SMALL ENGINE DIST., INC.
Hialeah, FL
(800) 433-2014 (N)
(305) 558-5718 |
| 3. AUTO ELECTRIC, INC.
Clearwater, FL
(800) 282-3479 (N)
(813) 446-3061 | 10. GUNTHER'S SERV. & SUPPLY
Kansas City, MO
(800) 397-1952 (N)
(816) 523-1952 | 17. OESTE DISTRIBUTING INC.
Phoenix, AZ
(800) 467-5113 (N)
(602) 272-1129 | 24. SOUTHWEST POWER
SUPPLY, INC.
Ft. Myers, FL
(813) 936-6272 |
| 4. BEBCO
Birmingham, AL
(800) 239-5190 (N)
(205) 250-6160 | 11. HANCE DISTRIBUTING
Plymouth, MN
(800) 535-1184 (N)
(612) 559-2299 | 18. OSCAR WILSON ENG. & PARTS
O'Fallon, MO
(800) 873-6722 (N)
(314) 978-1313 | 25. SPENCER ENGINES
Tampa, FL
(800) 966-4421 (N)
(813) 251-6889 |
| 5. BILLIOU'S
Porterville, CA
(800) 245-5468 (N)
(209) 784-4102 | 12. HENRY W. O'NEILL & ASSOC.
Victor, NY
(800) 724-3145 (N)
(716) 924-7900 | 19. ROMAR AGENCIES
Rio Piedras, PR
(809) 720-5959 | 26. SPITZER IND. PRODUCTS
Thornton, CO
(800) 346-3027 (N)
(303) 287-3612 |
| 6. CENTRAL FLORIDA ENG.
Orlando, FL
(407) 841-4301 | 13. MARR BROTHERS, INC.
Dallas, TX
(800) 627-7276 (N)
(214) 948-7387 | 20. RYOBI CANADA INC.
Cambridge, Ontario, Canada
(800) 265-6778 (N)
(519) 650-3022 | 27. TRI-STATE AIR COOLED ENG.
Johnson City, TN
(800) 334-9685 (N)
(615) 928-7107 |
| 7. DIXIE SALES COMPANY
Greensboro, NC
(800) 753-4943 (N)
(919) 375-7500 | 14. MEDART FENTON
Fenton, MO
(800) 888-7181 (N)
(314) 343-0515 | 21. RYOBI FACTORY SVC CTR #527
Seattle, WA
(800) 807-8898 (N)
(206) 368-7050 | |

RYOBI.

Factory Service Centers Centres de Service Après-vente de L'usine Centros de Servicio de la Fábrica

ARIZONA

1964 N. Alma School Rd. #10
Chandler, AZ 85224
(800) 660-7776
(602) 899-5807

CALIFORNIA

9699 Chapman Ave.
Garden Grove, CA 92641
(800) 597-9624
(714) 539-3170

FLORIDA

965-967 Semoran Blvd.
Casselberry, FL 32707
(800) 345-4889
(407) 260-2009

GEORGIA

Akers Mill Square
2969 J Cobb Pkwy.
Atlanta, GA 30339-5909
(800) 447-2192
(404) 953-6979

ILLINOIS

4334 Fox Valley Center Dr.
Aurora, IL 60504
(800) 310-2561
(708) 820-0776

MASSACHUSETTS

188 Needham St.
Newton, MA 02164
(800) 717-3657
(617) 630-2703

MINNESOTA

2519 W. 79th St.
Bloomington, MN 55431
(800) 276-0801
(612) 888-5591

NEW JERSEY

Colonial Square Mall
299 Route 22 E.
Green Brook, NJ 08812
(800) 847-5993
(908) 752-9052

TEXAS

2403 W. Airport Hwy.
Irving, TX 75062
(800) 345-7880
(214) 594-6682

WASHINGTON

14725 Aurora Ave. North
Suite A9 (rear of bldg)
Seattle, WA 98133
(800) 807-8898
(206) 368-7050

2-CYCLE OIL
ACETE 2-TIEMPOS

CONTAINS FUEL STABILIZERS

DIRECTIONS: Mix contents of bottle with 1 gallon (3.785l)
fresh gasoline (32:1 ratio).

INSTRUCCIONES: Mezcle el contenido de la botella con
3,785 litros (1 galon) de gasolina fresca
(proporcion de la mezcla 32:1).

RYOBI OUTDOOR PRODUCTS, INC.

Chandler, Arizona 85226-2434 1-800-345-TRIM

4 oz. (0.118L) #147543R