

Owner's Manual

**CRAFTSMAN®**

**13.5 HP  
ELECTRIC START  
42" MOWER  
6 SPEED TRANSAXLE  
LAWN TRACTOR**

Model No.  
**917.270411**

- Safety
- Assembly
- Operation
- Maintenance
- Repair Parts

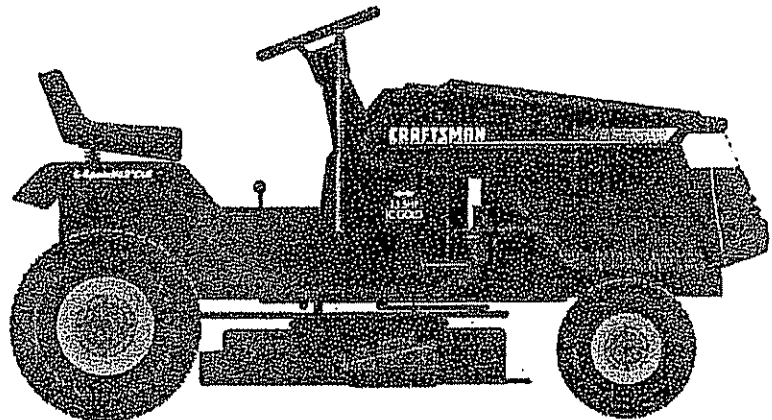

This product has a low emission engine which operates differently from previously built engines. Before you start the engine, read and understand this Owner's Manual.

**CAUTION:**

Read and follow all Safety Rules and Instructions before operating this equipment.

For answers to your questions about this product, Call:

**1-800-659-5917**  
Sears Craftsman Help Line  
5 am - 5 pm, Mon - Sat

Sears, Roebuck and Co., Hoffman Estates, IL 60179

## TABLE OF CONTENTS

Warranty .....	2	Maintenance .....	17
Safety Rules .....	2	Service and Adjustments .....	21
Product Specifications .....	5	Storage .....	27
Assembly .....	8	Troubleshooting .....	28
Operation .....	11	Repair Parts .....	34
Maintenance Schedule .....	17	Parts Ordering .....	Back Cover

## WARRANTY

### LIMITED ONE YEAR WARRANTY ON CRAFTSMAN RIDING EQUIPMENT

For one (1) year from the date of purchase, if this Craftsman Riding Equipment is maintained, lubricated and tuned up according to the instructions in the owner's manual, Sears will repair or replace, free of charge, any parts found to be defective in material or workmanship.

This Warranty does not cover:

- Expendable items which become worn during normal use, such as blades, spark plugs, air cleaners, belts, etc.
- Tire replacement or repair caused by punctures from outside objects, such as nails, thorns, stumps, or glass.
- Repairs necessary because of operator abuse, negligence, improper storage or accident or the failure to maintain the equipment according to the instructions contained in the owner's manual.
- Riding equipment used for commercial or rental purposes.

### LIMITED 90 DAY WARRANTY ON BATTERY

For ninety (90) days from date of purchase, if any battery included with this riding equipment proves defective in material or workmanship and our testing determines the battery will not hold a charge, Sears will replace the battery at no charge. In-home warranty service on your Craftsman riding equipment is available at no charge for 30 days from the date of purchase. Please contact your nearest service center. After 30 days from the date of purchase, warranty service is available by taking your Craftsman riding equipment to your nearest Sears Service Center. (In-home warranty service will still be available after 30 days from the date of purchase but a standard trip charge will apply). This warranty applies only while this product is in the United States. This Warranty gives you specific legal rights, and you may also have other rights which may vary from state to state.

Sears, Roebuck and Co., D/817 WA, Hoffman Estates, IL 60179

## SAFETY RULES

### GENERAL OPERATION

- Read, understand, and follow all instructions in the manual and on the machine before starting.
- Only allow responsible adults, who are familiar with the instructions, to operate the machine.
- Clear the area of objects such as rocks, toys, wire, etc., which could be picked up and thrown by the blade.
- Be sure the area is clear of other people before mowing. Stop machine if anyone enters the area.
- Never carry passengers.
- Do not mow in reverse unless absolutely necessary. Always look down and behind before and while backing.
- Be aware of the mower discharge direction and do not point it at anyone. Do not operate the mower without either the entire grass catcher or the guard in place.
- Slow down before turning.
- Never leave a running machine unattended. Always turn off blades, set parking brake, stop engine, and remove keys before dismounting.

## SAFETY RULES

- Turn off blades when not mowing.
- Stop engine before removing grass catcher or unclogging chute.
- Mow only in daylight or good artificial light.
- Do not operate the machine while under the influence of alcohol or drugs.
- Watch for traffic when operating near or crossing roadways.
- Use extra care when loading or unloading the machine into a trailer or truck.

### SLOPE OPERATION

Slopes are a major factor related to loss-of-control and tipover accidents, which can result in severe injury or death. All slopes require extra caution. If you cannot back up the slope or if you feel uneasy on it, do not mow it.

#### DO:

- Mow up and down slopes, not across.
- Remove obstacles such as rocks, tree limbs, etc.
- Watch for holes, ruts, or bumps. Uneven terrain could overturn the machine. Tall grass can hide obstacles.
- Use slow speed. Choose a low gear so that you will not have to stop or shift while on the slope.
- Follow the manufacturer's recommendations for wheel weights or counterweights to improve stability.
- Use extra care with grass catchers or other attachments. These can change the stability of the machine.
- Keep all movement on the slopes slow and gradual. Do not make sudden changes in speed or direction.
- Avoid starting or stopping on a slope. If tires lose traction, disengage the blades and proceed slowly straight down the slope.

#### DO NOT:

- *Do not* turn on slopes unless necessary, and then, turn slowly and gradually downhill, if possible.
- *Do not* mow near drop-offs, ditches, or embankments. The mower could suddenly turn over if a wheel is over the edge of a cliff or ditch, or if an edge caves in.
- *Do not* mow on wet grass. Reduced traction could cause sliding.

- *Do not* try to stabilize the machine by putting your foot on the ground.
- *Do not* use grass catcher on steep slopes.

### CHILDREN

Tragic accidents can occur if the operator is not alert to the presence of children. Children are often attracted to the machine and the mowing activity. *Never* assume that children will remain where you last saw them.

- Keep children out of the mowing area and under the watchful care of another responsible adult.
- Be alert and turn machine off if children enter the area.
- Before and when backing, look behind and down for small children.
- Never carry children. They may fall off and be seriously injured or interfere with safe machine operation.
- Never allow children to operate the machine.
- Use extra care when approaching blind corners, shrubs, trees, or other objects that may obscure vision.

### SERVICE

- Use extra care in handling gasoline and other fuels. They are flammable and vapors are explosive.
  - Use only an approved container.
  - Never remove gas cap or add fuel with the engine running. Allow engine to cool before refueling. Do not smoke.
  - Never refuel the machine indoors.
  - Never store the machine or fuel container inside where there is an open flame, such as a water heater.
- Never run a machine inside a closed area.
- Keep nuts and bolts, especially blade attachment bolts, tight and keep equipment in good condition.
- Never tamper with safety devices. Check their proper operation regularly.
- Keep machine free of grass, leaves, or other debris build-up. Clean oil or fuel spillage. Allow machine to cool before storing.
- Stop and inspect the equipment if you strike an object. Repair, if necessary, before restarting.

## SAFETY RULES

- Never make adjustments or repairs with the engine running.
- Grass catcher components are subject to wear, damage, and deterioration, which could expose moving parts or allow objects to be thrown. Frequently check components and replace with manufacturer's recommended parts, when necessary.
- Mower blades are sharp and can cut. Wrap the blade(s) or wear gloves, and use extra caution when servicing them.
- Check brake operation frequently. Adjust and service as required.

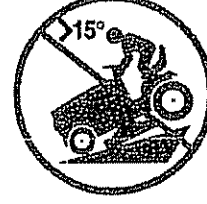
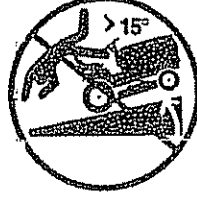

- Be sure the area is clear of other people before mowing. Stop machine if anyone enters the area.
- Never carry passengers.
- Do not mow in reverse unless absolutely necessary. Always look down and behind before and while backing.
- Never carry children. They may fall off and be seriously injured or interfere with safe machine operation.
- Keep children out of the mowing area and under the watchful care of another responsible adult.
- Be alert and turn machine off if children enter the area.
- Before and when backing, look behind and down for small children.
- Mow up and down slopes (15° Max), not across.
- Remove obstacles such as rocks, tree limbs, etc.
- Watch for holes, ruts, or bumps. Uneven terrain could overturn the machine. *Tall grass can hide obstacles.*
- Use slow speed. Choose a low gear so that you will not have to stop or shift while on the slope.
- Avoid starting or stopping on a slope. If tires lose traction, disengage the blades and proceed slowly *straight* down the slope.
- *Do not* turn on slopes unless necessary, and then, turn slowly and gradually downhill, if possible.

▲ Look for this symbol to point out important safety precautions. It means CAUTION!!! BECOME AWARE!!! YOUR SAFETY IS INVOLVED.

▲ **CAUTION:** In order to prevent accidental starting when setting up, transporting, adjusting or making repairs always disconnect spark plug wire and place wire where it cannot contact spark plug.

▲ **WARNING:** The engine exhaust from this product contains chemicals known to the State of California to cause cancer, birth defects, or other reproductive harm.

GASOLINE CAPACITY AND TYPE:	1.25 GALLONS UNLEADED REGULAR
OIL TYPE (API-SF/SG/SH):	SAE 30 (above 32°F) SAE 5W-30 (below 32°F)
OIL CAPACITY:	3.0 PINTS
SPARK PLUG: (GAP: .030")	Champlon J19LM or RJ19LM STD361458
VALVE CLEARANCE:	INTAKE: .005"-.007" EXHAUST: .009"-.011"
GROUND SPEED (MPH):	FORWARD: 1ST 1.0 2ND 1.3 3RD 2.1 4TH 3.1 5TH 4.0 6TH 5.1 REVERSE: 1.6
TIRE PRESSURE:	FRONT: 14 PSI REAR: 12PSI
CHARGING SYSTEM:	3 AMPS BATTERY 5 AMPS HEADLIGHTS
BATTERY:	AMP/HR: 25 MIN. CCA: 190 CASE SIZE: U1R
BLADE BOLT TORQUE:	27-35 FT. LBS.

**CONGRATULATIONS** on your purchase of a Craftsman Tractor. It has been designed, engineered and manufactured to give you the best possible dependability and performance.

Should you experience any problem you cannot easily remedy, please contact your nearest Sears Authorized Service Center. We have competent, well-trained technicians and the proper tools to service or repair this tractor. Please read and retain this manual. The instructions will enable you to assemble and maintain your tractor properly. Always observe the "SAFETY RULES".

A Sears Maintenance Agreement is available on this product. Contact your nearest Sears store for details.

### CUSTOMER RESPONSIBILITIES

- Read and observe the safety rules.
- Follow a regular schedule in maintaining, caring for and using your tractor.
- Follow the instructions under "Maintenance" and "Storage" sections of this owner's manual.

**⚠ WARNING:** This tractor is equipped with an internal combustion engine and should not be used on or near any unimproved forest-covered, brush-covered or grass-covered land unless the engine's exhaust system is equipped with a spark arrester meeting applicable local or state laws (if any). If a spark arrester is used, it should be maintained in effective working order by the operator.

In the state of California the above is required by law (Section 4442 of the California Public Resources Code). Other states may have similar laws. Federal laws apply on federal lands. A spark arrester for the muffler is available through your nearest Sears Authorized Service Center (See REPAIR PARTS section of this manual).

# CONTENTS OF HARDWARE PACK

Parts Bag contents shown full size

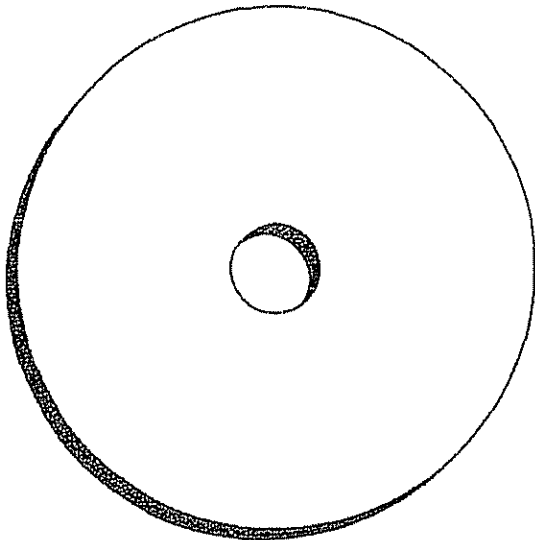

(1) Large Flat Washer

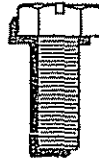

(2) Sheet Metal Screws  
#10-16 x 1/2

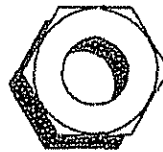

(1) Locknut  
3/8-24

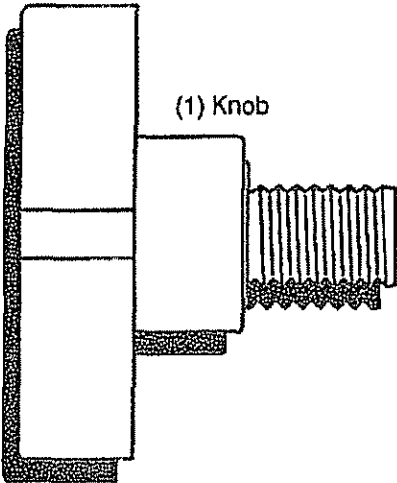

(1) Knob

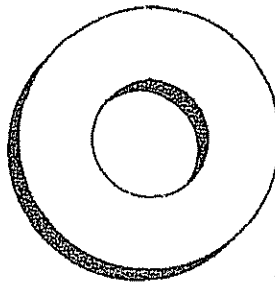

(1) Washer  
17/32 x 1-3/16 x 12 Gauge

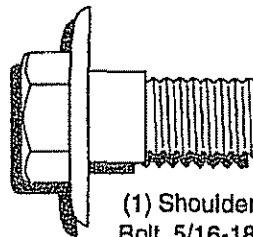

(1) Shoulder Bolt  
5/16-18

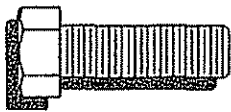

(2) Hex Bolts 1/4-20 x 3/4



(2) Lock Washers 1/4

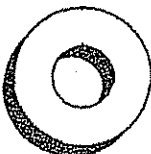

(2) Washers  
9/32 x 5/8 x 16 Gauge



(2) Hex Nuts  
1/4-20

# CONTENTS OF HARDWARE PACK

Parts packed separately in carton

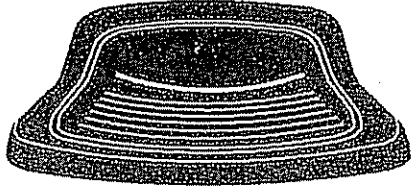

Seat

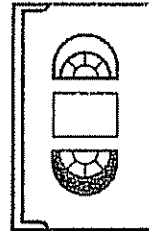

Video  
Cassette

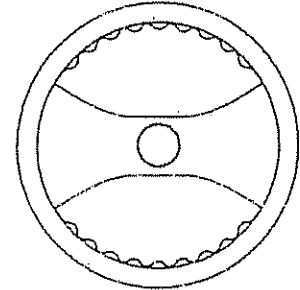

Steering  
Wheel

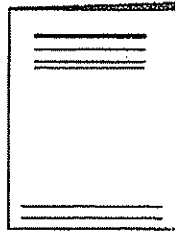

Manual



Steering  
Boot

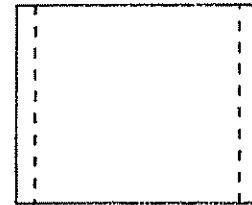

Parts Bag

Parts Bag contents not shown full size

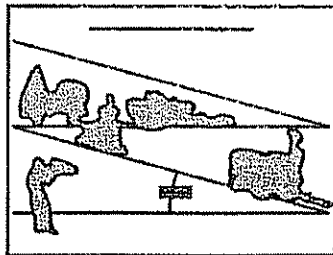

Slope Sheet

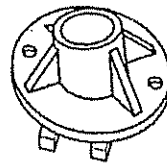

Steering  
Bushing



Steering  
Wheel  
Insert



(2) Keys

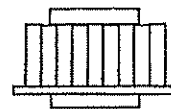

Steering Wheel  
Adapter

## ASSEMBLY

Your new tractor has been assembled at the factory with exception of those parts left unassembled for shipping purposes. To ensure safe and proper operation of your tractor all parts and hardware you assemble must be tightened securely. Use the correct tools as necessary to insure proper tightness. Review the video cassette before you begin.

### TOOLS REQUIRED FOR ASSEMBLY

A socket wrench set will make assembly easier. Standard wrench sizes you need are listed below.

- (1) 9/16" wrench
- (2) 7/16" wrenches
- (2) 1/2" wrench
- (1) Phillips Screwdriver
- (1) Pliers
- (1) Tire pressure gauge
- (1) Utility knife

When right or left hand is mentioned in this manual, it means, from your point of view, when you are in the operating position (seated behind the steering wheel).

### TO REMOVE TRACTOR FROM CARTON

#### UNPACK CARTON

- Remove all accessible loose parts and parts boxes from shipping carton (See page 6).
- Cut, from top to bottom, along lines on all four corners of shipping carton, and lay panels flat.
- Check for any additional loose parts or boxes and remove.

### BEFORE ROLLING TRACTOR OFF SKID

#### ATTACH STEERING WHEEL

- Slide the steering bushing over the steering shaft.
- Raise steering shaft forward until screw holes in dash line up with steering bushing. Install two (2) sheet metal screws and tighten securely.
- Position steering boot over steering shaft.
- Place tabs of steering boot over tab slots in dash and push down to secure.
- Slide steering wheel adapter onto upper steering shaft.
- Position front wheels of the tractor so they are pointing straight forward.
- Position steering wheel so cross bars are horizontal (left to right) and slide onto adapter.
- Assemble large flat washer and 3/8-24 locknut and tighten securely.

- Snap steering wheel insert into center of steering wheel.
- Remove protective materials from tractor hood and grill.

**IMPORTANT:** Check for and remove any staples in skid that may puncture tires where tractor is to roll off skid.

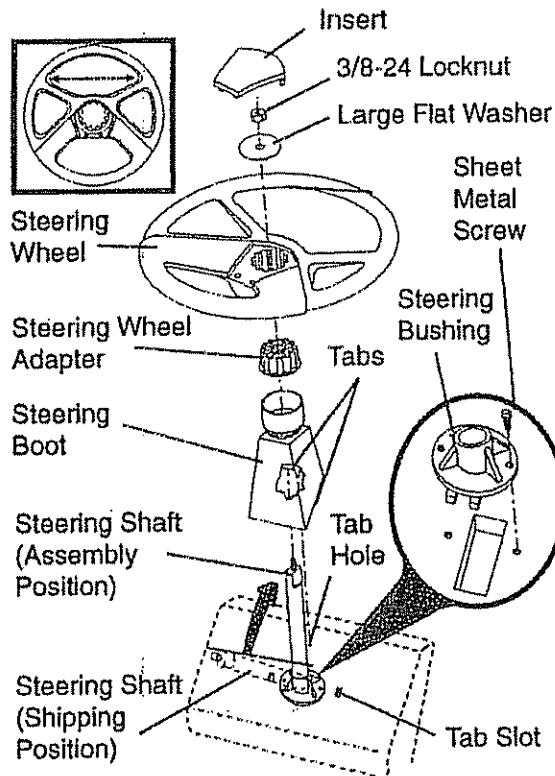

### TO ROLL TRACTOR OFF SKID (See Operation section for location and function of controls)

- Press lift lever plunger and raise attachment lift lever to its highest position.
- Release parking brake by depressing clutch/brake pedal.
- Place gearshift lever in neutral (N) position.
- Roll tractor forward off skid.
- Remove banding holding discharge guard up against tractor.



## HOW TO SET UP YOUR TRACTOR CONNECT BATTERY

**⚠ CAUTION:** Do not short battery terminals by allowing a wrench or any other object to contact both terminals at the same time. Before connecting battery, remove metal bracelets, wristwatch bands, rings, etc. Positive terminal must be connected first to prevent sparking from accidental grounding.

- Remove cardboard packing from seat pan and lift seat pan to raised position.
- Open battery box door and remove protective plastic.
- Remove terminal protective caps and discard.
- If this battery is put into service after month and year indicated on label (label located between terminals) charge battery for minimum of one hour at 6-10 amps.
- First connect RED battery cable to positive (+) terminal with hex bolt, flat washer, lock washer and hex nut as shown. Tighten securely.
- Connect BLACK grounding cable to negative (-) terminal with remaining hex bolt, flat washer, lock washer and hex nut. Tighten securely.
- Close battery box door. Open battery box door for:
  - Inspection for secure connections (to tighten hardware).
  - Inspection for corrosion.
  - Testing battery.
  - Jumping (if required).
  - Periodic charging.

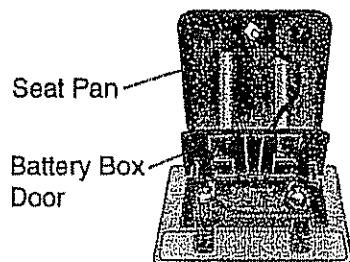
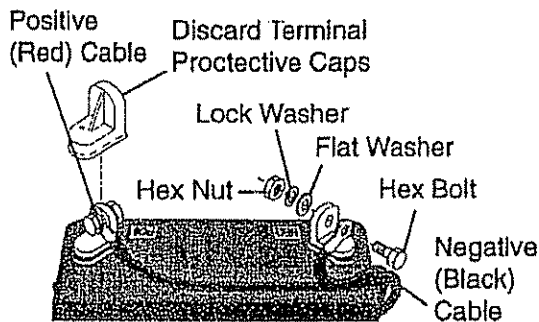

## INSTALL SEAT

Adjust seat before tightening adjustment knob.

- Remove cardboard packing on seat pan.
- Place seat on seat pan and assemble shoulder bolt. Tighten shoulder bolt securely.
- Assemble adjustment knob and flat washer loosely. Do not tighten.
- Lower seat into operating position and sit on seat.
- Slide seat until a comfortable position is reached which allows you to press clutch/brake pedal all the way down.
- Get off seat without moving its adjusted position.
- Raise seat and tighten adjustment knob securely.

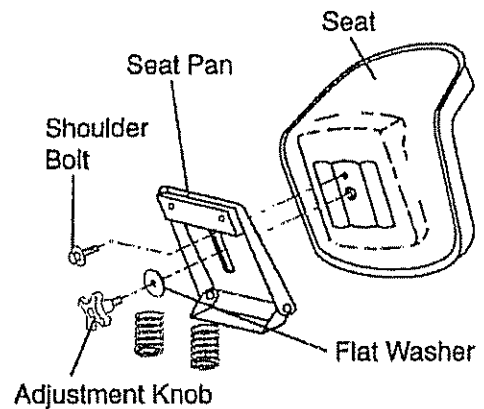

### **CHECK DECK LEVELNESS**

For best cutting results, mower housing should be properly leveled. See "TO LEVEL MOWER HOUSING" in the Service and Adjustments section of this manual.

### **CHECK FOR PROPER POSITION OF ALL BELTS**

See the figures that are shown for replacing motion and mower blade drive belts in the Service and Adjustments section of this manual. Verify that the belts are routed correctly.

### **CHECK BRAKE SYSTEM**

After you learn how to operate your tractor, check to see that the brake is properly adjusted. See "TO ADJUST BRAKE" in the Service and Adjustments section of this manual.

### **✓ CHECKLIST**

PLEASE REVIEW THE FOLLOWING CHECKLIST:

- ✓ All assembly instructions have been completed.
- ✓ No remaining loose parts in carton.
- ✓ Battery is properly prepared and charged. (Minimum 1 hour at 6 amps).
- ✓ Seat is adjusted comfortably and tightened securely.
- ✓ All tires are properly inflated. (For shipping purposes, the tires were overinflated at the factory).
- ✓ Be sure mower deck is properly leveled side-to-side/front-to-rear for best cutting results. (Tires must be properly inflated for leveling).
- ✓ Check mower and drive belts. Be sure they are routed properly around pulleys and inside all belt keepers.
- ✓ Check wiring. See that all connections are still secure and wires are properly clamped.

WHILE LEARNING HOW TO USE YOUR TRACTOR, PAY EXTRA ATTENTION TO THE FOLLOWING IMPORTANT ITEMS:

- ✓ Engine oil is at proper level.
- ✓ Fuel tank is filled with fresh, clean, regular unleaded gasoline.
- ✓ Become familiar with all controls - their location and function. Operate them before you start the engine.
- ✓ Be sure brake system is in safe operating condition.

# OPERATION

These symbols may appear on your tractor or in literature supplied with the product. Learn and understand their meaning.

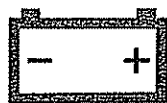

BATTERY



CAUTION OR WARNING



REVERSE



FORWARD



FAST



SLOW



ENGINE ON



ENGINE OFF



OIL PRESSURE



LIGHTS ON

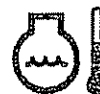

OVER TEMP LIGHT



MOWER LIFT



FUEL



CHOKE



MOWER HEIGHT



PARKING BRAKE LOCKED



UNLOCKED



ATTACHMENT CLUTCH ENGAGED



REVERSE



NEUTRAL



HIGH



LOW

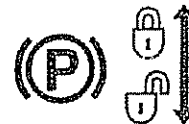

PARKING BRAKE



IGNITION

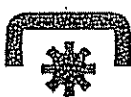

ATTACHMENT CLUTCH DISENGAGED



KEEP AREA CLEAR



SLOPE HAZARDS



(SEE SAFETY RULES SECTION)



DANGER, KEEP HANDS AND FEET AWAY

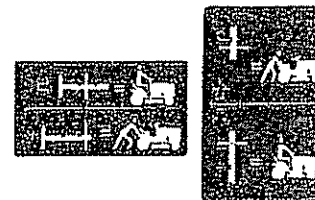

HYDROSTATIC FREE WHEEL  
(Hydro Models only)

## KNOW YOUR TRACTOR

### READ THIS OWNER'S MANUAL AND SAFETY RULES BEFORE OPERATING YOUR TRACTOR

Compare the illustrations with your tractor to familiarize yourself with the locations of various controls and adjustments. Save this manual for future reference.

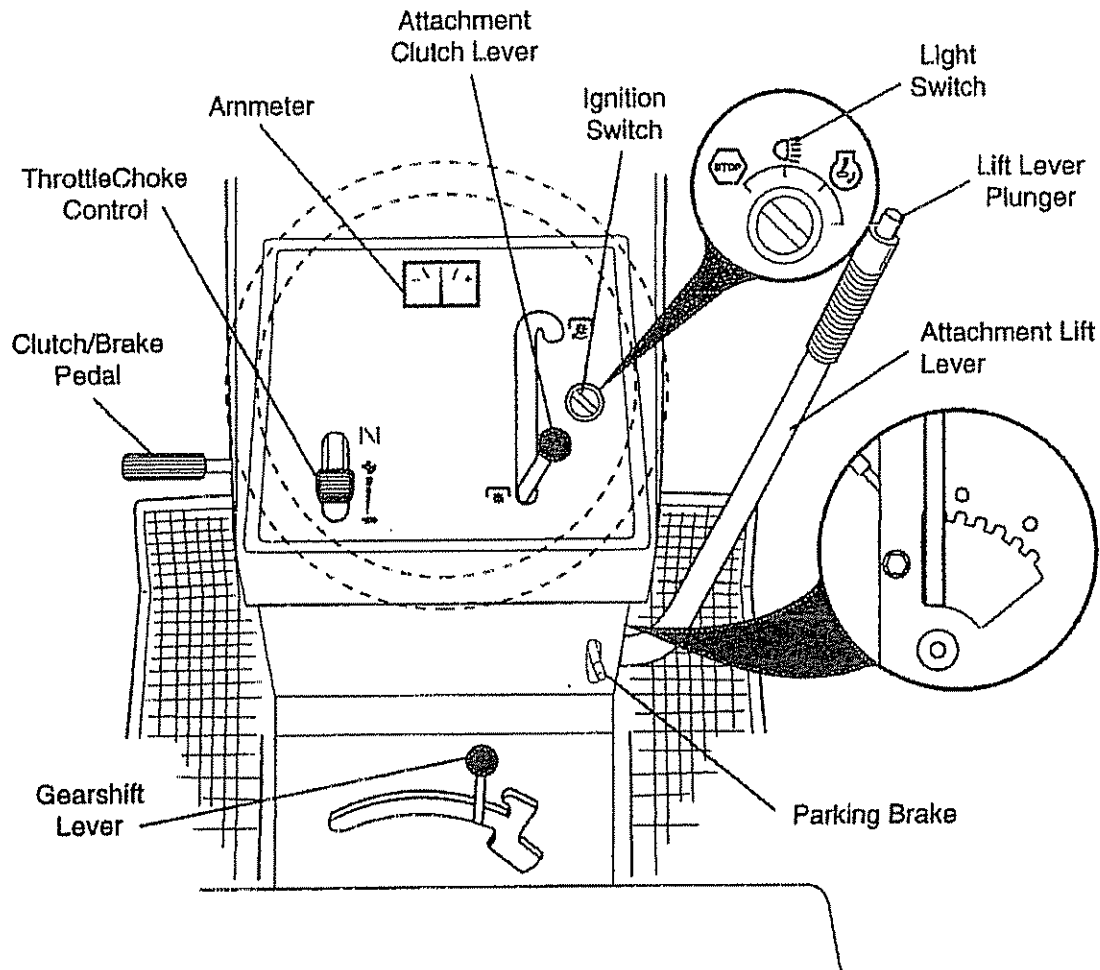

---

Our tractors conform to the safety standards of the American National Standards Institute.

---

**ATTACHMENT CLUTCH LEVER:** Used to engage the mower blades, or other attachments mounted to your tractor.

**LIGHT SWITCH:** Turns the headlights on and off.

**THROTTLE/CHOKE CONTROL:** Used for starting and controlling engine speed.

**CLUTCH/BRAKE PEDAL:** Used for declutching and braking the tractor and starting the engine.

**PARKING BRAKE:** Locks clutch/brake pedal into the brake position.

**GEARSHIFT LEVER:** Selects the speed and direction of tractor.

**ATTACHMENT LIFT LEVER:** Used to raise, lower, and adjust the mower deck or other attachments mounted to your tractor.

**LIFT LEVER PLUNGER:** Used to release attachment lift lever when changing its position.

**IGNITION SWITCH:** Used for starting and stopping the engine.

**AMMETER:** Indicates battery charging (+) or discharging (-).



The operation of any tractor can result in foreign objects thrown into the eyes, which can result in severe eye damage. Always wear safety glasses or eye shields while operating your tractor or performing any adjustments or repairs. We recommend a wide vision safety mask over the spectacles, or standard safety glasses.

## HOW TO USE YOUR TRACTOR

Your tractor is equipped with an operator presence sensing switch. When engine is running, any attempt by the operator to leave the seat without first setting the parking brake will shut off the engine.

### TO SET PARKING BRAKE

- Depress clutch/brake pedal into full "BRAKE" position and hold.
- Place parking brake lever in "ENGAGED" position and release pressure from clutch/brake pedal. Pedal should remain in "BRAKE" position. Make sure parking brake will hold tractor secure.

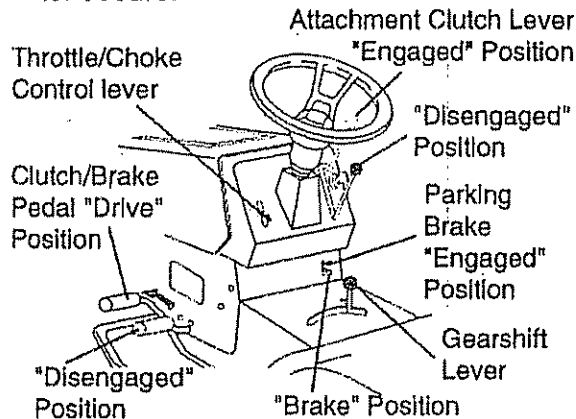

## STOPPING

### MOWER BLADES -

- To stop mower blades, move attachment clutch lever to "DISENGAGED" position.

### GROUND DRIVE -

- To stop ground drive, depress clutch/brake pedal into full "BRAKE" position.
- Move gearshift lever to neutral (N) position.

### ENGINE -

- Move throttle control to slow position.

**NOTE:** Failure to move throttle control to slow position and allowing engine to idle before stopping may cause engine to "backfire".

- Turn ignition key to "OFF" position and remove key. Always remove key when leaving tractor to prevent unauthorized use.

- Never use choke to stop engine.

**NOTE:** Under certain conditions when tractor is standing idle with the engine running, hot engine exhaust gases may cause "browning" of grass. To eliminate this possibility, always stop engine when stopping tractor on grass areas.

**CAUTION:** Always stop tractor completely, as described above, before leaving the operator's position; to empty grass catcher, etc.

## THROTTLE CONTROL

Always operate engine at full throttle.

- Operating engine at less than full throttle reduces the battery charging rate.
- Full throttle offers the best bagging and mower performance.

## TO MOVE FORWARD AND BACKWARD

The direction and speed of movement is controlled by the gearshift lever.

- Start tractor with clutch/brake pedal depressed and gearshift lever in neutral (N) position.
- Move gearshift lever to desired position.
- Slowly release clutch/brake pedal to start movement.

**IMPORTANT:** Bring tractor to a complete stop before shifting or changing gears. Failure to do so will shorten the useful life of your transaxle

## TO ADJUST MOWER CUTTING HEIGHT

The position of the attachment lift lever determines the cutting height.

- Grasp lift lever.
- Press plunger with thumb and move lever to desired position.

The cutting height range is approximately 1-1/2 to 4". The heights are measured from the ground to the blade tip with the engine not running. These heights are approximate and may vary depending upon soil conditions, height of grass and types of grass being mowed.

- The average lawn should be cut to approximately 2-1/2 inches during the cool season and to over 3 inches during hot months. For healthier and better looking lawns, mow often and after moderate growth.

- For best cutting performance, grass over 6 inches in height should be mowed twice. Make the first cut relatively high; the second to desired height.

### TO OPERATE MOWER

Your tractor is equipped with an operator presence sensing switch. Any attempt by the operator to leave the seat with the engine running and the attachment clutch engaged will shut off the engine.

- Select desired height of cut.
- Start mower blades by engaging attachment clutch control.
- TO STOP MOWER BLADES - disengage attachment clutch control.

**▲ CAUTION:** Do not operate the mower without either the entire grass catcher, on mowers so equipped, or the discharge guard in place.

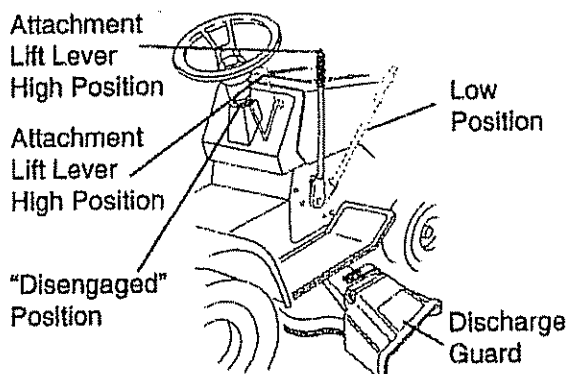

### TO OPERATE ON HILLS

**▲ CAUTION:** Do not drive up or down hills with slopes greater than 15° and do not drive across any slope. A slope guide at the back of your manual is provided for your use.

- Choose the slowest speed before starting up or down hills.
- Avoid stopping or changing speed on hills.
- If slowing is necessary, move throttle control lever to slower position.
- If stopping is absolutely necessary, push clutch/brake pedal quickly to brake position and engage parking brake.
- Move gearshift lever to 1st gear. Be sure you have allowed room for tractor to roll slightly as you restart movement.
- To restart movement, slowly release parking brake and clutch/brake pedal.
- Make all turns slowly.

### TO TRANSPORT

- Raise attachment lift to highest position with attachment lift control.

- When pushing or towing your tractor, be sure gearshift lever is in neutral (N) position.
- Do not push or tow tractor at more than five (5) MPH.

**NOTE:** To protect hood from damage when transporting your tractor on a truck or a trailer, be sure hood is closed and secured to tractor. Use an appropriate means of tying hood to tractor (rope, cord, etc.).

### BEFORE STARTING THE ENGINE

#### CHECK ENGINE OIL LEVEL

- The engine in your tractor has been shipped, from the factory, already filled with summer weight oil.
- Check engine oil with tractor on level ground.
- Remove oil fill cap/dipstick and wipe clean, reinsert the dipstick and screw cap tight, wait for a few seconds, remove and read oil level. If necessary, add oil until "FULL" mark on dipstick is reached. Do not overfill.
- For cold weather operation you should change oil for easier starting (See "OIL VISCOSITY CHART" in the Maintenance section of this manual).
- To change engine oil, see the Maintenance section in this manual.

#### ADD GASOLINE

- Fill fuel tank. Use fresh, clean, regular unleaded gasoline with a minimum of 87 octane. (Use of leaded gasoline will increase carbon and lead oxide deposits and reduce valve life). Do not mix oil with gasoline. Purchase fuel in quantities that can be used within 30 days to assure fuel freshness.

**IMPORTANT:** When operating in temperatures below 32°F(0°C), use fresh, clean winter grade gasoline to help insure good cold weather starting.

**▲ WARNING:** Experience indicates that alcohol blended fuels (called gasohol or using ethanol or methanol) can attract moisture which leads to separation and formation of acids during storage. Acidic gas can damage the fuel system of an engine while in storage. To avoid engine problems, the fuel system should be emptied before storage of 30 days or longer. Drain the gas tank, start the engine and let it run until the fuel lines and carburetor are empty. Use fresh fuel next season.

See Storage Instructions for additional information. Never use engine or carburetor cleaner products in the fuel tank or permanent damage may occur.

**▲CAUTION:** Fill to bottom of gas tank filler neck. Do not overfill. Wipe off any spilled oil or fuel. Do not store, spill or use gasoline near an open flame.

#### **TO START ENGINE**

When starting the engine for the first time or if the engine has run out of fuel, it will take extra cranking time to move fuel from the tank to the engine.

- Sit on seat in operating position, depress clutch/brake pedal and set parking brake.
- Place gear shift lever in neutral (N) position.
- Move attachment clutch to "DISENGAGED" position.
- Move throttle control to choke position.

**NOTE:** Before starting, read the warm and cold starting procedures below.

- Insert key into Ignition and turn key clockwise to "START" position and release key as soon as engine starts. Do not run starter continuously for more than fifteen seconds per minute. If the engine does not start after several attempts, move throttle control to fast position, wait a few minutes and try again. If engine still does not start, move the throttle control back to the choke position and retry.

#### **WARM WEATHER STARTING (50° F and above)**

- When engine starts, move the throttle control to the fast position.
- The attachments and ground drive can now be used. If the engine does not accept the load, restart the engine and allow it to warm up for one minute using the choke as described above.

#### **COLD WEATHER STARTING ( 50° F AND BELOW)**

- When engine starts, allow engine to run with the throttle control in the choke position until the engine runs roughly, then move throttle control to fast position. This may require an engine warm-up period from several seconds to several minutes, depending on the temperature.
- The attachments can also be used during the engine warm-up period.

**NOTE:** If at a high altitude (above 3000 feet) or in cold temperatures (below 32 F) the carburetor fuel mixture may need to be adjusted for best engine performance. See "TO ADJUST CARBURETOR" in the Service and Adjustments section of this manual.

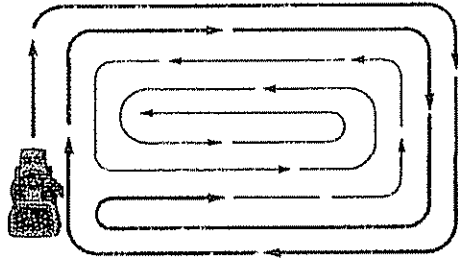

### MOWING TIPS

- Tire chains cannot be used when the mower housing is attached to tractor.
- Mower should be properly leveled for best mowing performance. See "TO LEVEL MOWER HOUSING" in the Service and Adjustments section of this manual.
- The left hand side of mower should be used for trimming.
- Drive so that clippings are discharged onto the area that has been cut. Have the cut area to the right of the machine. This will result in a more even distribution of clippings and more uniform cutting.
- When mowing large areas, start by turning to the right so that clippings will discharge away from shrubs, fences, driveways, etc. After one or two rounds, mow in the opposite direction making left hand turns until finished
- If grass is extremely tall, it should be mowed twice to reduce load and possible fire hazard from dried clippings. Make first cut relatively high; the second to the desired height.
- Do not mow grass when it is wet. Wet grass will plug mower and leave undesirable clumps. Allow grass to dry before mowing.
- **Always operate engine at full throttle when mowing** to assure better mowing performance and proper discharge of material. Regulate ground speed by selecting a low enough gear to give the mower the best cutting performance as well as the quality of cut desired.
- When operating attachments, select a ground speed that will suit the terrain and give best performance of the attachment being used.



# MAINTENANCE

## CUSTOMER RESPONSIBILITIES

MAINTENANCE SCHEDULE		SERVICE DATES						
FILL IN DATES AS YOU COMPLETE REGULAR SERVICE		BEFORE EACH USE	EVERY 8 HOURS	EVERY 25 HOURS	EVERY 50 HOURS	EVERY 100 HOURS	EVERY SEASON	BEFORE STORAGE
<b>T R A C T O R</b>	Check Brake Operation	✓	✓					
	Check Tire Pressure	✓	✓					
	Check Operator Presence and Interlock Systems	✓						
	Check for Loose Fasteners	✓			✓ <sub>7</sub>	✓		
	Sharpen/Replace Mower Blades			✓ <sub>1</sub>				
	Lubrication Chart			✓		✓		
	Check Battery Level			✓ <sub>6</sub>				
	Clean Battery and Terminals/Recharge			✓		✓		
	Check Transaxle Cooling			✓				
	Adjust Blade Belt(s) Tension					✓ <sub>5</sub>		
	Adjust Motion Drive Belt(s) Tension					✓ <sub>5</sub>		
	<b>E N G I N E</b>	Check Engine Oil Level	✓	✓				
Change Engine Oil				✓ <sub>1,2,3</sub>		✓		
Clean Air Filter				✓ <sub>2</sub>				
Clean Air Screen				✓ <sub>2</sub>				
Inspect Muffler/Spark Arrester					✓			
Replace Oil Filter (if equipped)						✓ <sub>1,2</sub>		
Clean Engine Cooling Fins						✓ <sub>2</sub>		
Replace Spark Plug						✓	✓	
Replace Air Filter Paper Cartridge						✓ <sub>2</sub>		
Replace Fuel Filter							✓	

- 1 - Change more often when operating under a heavy load or in high ambient temperatures.    5 - If equipped with adjustable system.  
 2 - Service more often when operating in dirty or dusty conditions.    6 - Not required if equipped with maintenance-free battery.  
 3 - If equipped with oil filter, change oil every 50 hours.    7 - Tighten front axle pivot bolt to 35 ft.-lbs. maximum.

### GENERAL RECOMMENDATIONS

The warranty on this tractor does not cover items that have been subjected to operator abuse or negligence. To receive full value from the warranty, operator must maintain tractor as instructed in this manual. Some adjustments will need to be made periodically to properly maintain your tractor. All adjustments in the Service and Adjustments section of this manual should be checked at least once each season.

- Once a year you should replace the spark plug, clean or replace air filter, and check blades and belts for wear. A new spark plug and clean air filter assure proper air-fuel mixture and help your engine run better and last longer.

### BEFORE EACH USE

- Check engine oil level.
- Check brake operation.
- Check tire pressure.
- Check operator presence and interlock systems for proper operation.
- Check for loose fasteners.

### LUBRICATION CHART

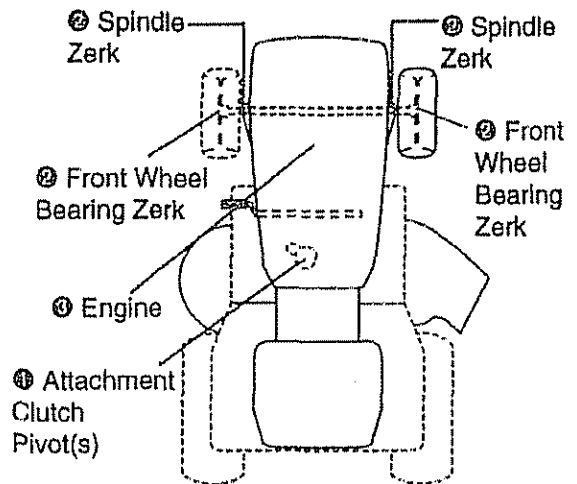

- ① SAE 30 or 10w30 Motor OIL
- ② General Purpose Grease
- ③ Refer to Maintenance "Engine" Section

**IMPORTANT:** Do not oil or grease the pivot points which have special nylon bearings. Viscous lubricants will attract dust and dirt that will shorten the life of the self-lubricating bearings. If you feel they must be lubricated, use only a dry, powdered graphite type lubricant sparingly.

## TRACTOR

Always observe safety rules when performing any maintenance.

### BRAKE OPERATION

If tractor requires more than six (6) feet stopping distance at high speed in highest gear, then brake must be adjusted. (See "TO ADJUST BRAKE" in the Service and Adjustments section of this manual).

### TIRES

- Maintain proper air pressure in all tires (See "PRODUCT SPECIFICATIONS" on page 5 of this manual).
- Keep tires free of gasoline, oil, or insect control chemicals which can harm rubber.
- Avoid stumps, stones, deep ruts, sharp objects and other hazards that may cause tire damage.

**NOTE:** To seal tire punctures and prevent flat tires due to slow leaks, tire sealant may be purchased from your local parts dealer. Tire sealant also prevents tire dry rot and corrosion.

### BLADE CARE

For best results mower blades must be kept sharp. Replace bent or damaged blades.

### BLADE REMOVAL

- Raise mower to highest position to allow access to blades.
- Remove hex bolt, lock washer and flat washer securing blade.
- Install new or resharpened blade with trailing edge up towards deck as shown.
- Reassemble hex bolt, lock washer and flat washer in exact order as shown.
- Tighten bolt securely (27-35 Ft. Lbs. torque).

**IMPORTANT:** Blade bolt is Grade 8 heat treated.

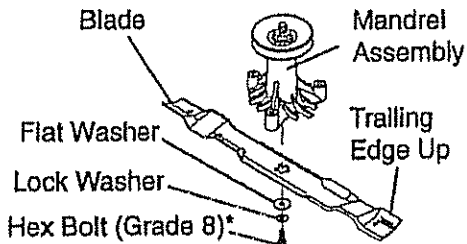

\*A Grade 8 heat treated bolt can be identified by six lines on the bolt head.

### TO SHARPEN BLADE

**NOTE:** We do not recommend sharpening blade, but if you do, be sure the blade is balanced.

Care should be taken to keep the blade balanced. An unbalanced blade will cause excessive vibration and eventual damage to mower and engine.

- The blade can be sharpened with a file or on a grinding wheel. Do not attempt to sharpen while it is on the mower.
- To check blade balance, you will need a 5/8" diameter steel bolt, pin, or a cone balancer. (When using a cone balancer, follow the instructions supplied with balancer).

**NOTE:** Do not use a nail for balancing blade. The lobes of the center hole may appear to be centered, but are not.

- Slide blade onto an unthreaded portion of the steel bolt or pin and hold the bolt or pin parallel with the ground. If blade is balanced, it should remain in a horizontal position. If either end of the blade moves downward, sharpen the heavy end until the blade is balanced.

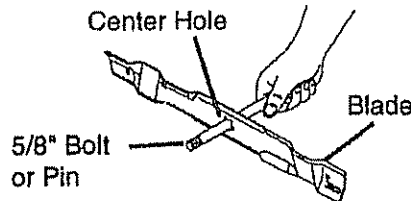

### BATTERY

Your tractor has a battery charging system which is sufficient for normal use. However, periodic charging of the battery with an automotive charger will extend its life.

- Keep battery and terminals clean.
- Keep battery bolts tight.
- Keep small vent holes open.
- Recharge at 6-10 amperes for 1 hour.

**NOTE:** The original equipment battery on your tractor is maintenance free. Do not attempt to open or remove caps or covers. Adding or checking level of electrolyte is not necessary.

### TO CLEAN BATTERY AND TERMINALS

Corrosion and dirt on the battery and terminals can cause the battery to "leak" power.

- Remove terminal guard.
- Disconnect BLACK battery cable first then RED battery cable and remove battery from tractor.

## ENGINE

- Rinse the battery with plain water and dry.
- Clean terminals and battery cable ends with wire brush until bright.
- Coat terminals with grease or petroleum jelly.
- Reinstall battery (See "CONNECT BATTERY" in the Assembly section of this manual).

### V-BELTS

Check V-belts for deterioration and wear after 100 hours of operation and replace if necessary. The belts are not adjustable. Replace belts if they begin to slip from wear.

### TRANSAXLE COOLING

Keep transaxle free from build-up of dirt and chaff which can restrict cooling.

### ENGINE

#### LUBRICATION

Only use high quality detergent oil rated with API service classification SF, SG or SH. Select the oil's SAE viscosity grade according to your expected operating temperature.

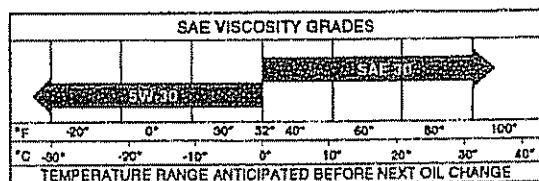

**NOTE:** Although multi-viscosity oils (5W30, 10W30 etc.) improve starting in cold weather, these multi-viscosity oils will result in increased oil consumption when used above 32°F. Check your engine oil level more frequently to avoid possible engine damage from running low on oil. Change the oil after every 25 hours of operation or at least once a year if the tractor is not used for 25 hours in one year.

Check the crankcase oil level before starting the engine and after each eight (8) hours of operation. Tighten oil fill cap/dipstick securely each time you check the oil level.

#### TO CHANGE ENGINE OIL

Determine temperature range expected before oil change. All oil must meet API service classification SF, SG or SH.

- Be sure tractor is on level surface.
- Oil will drain more freely when warm.

- Catch oil in a suitable container.
- Remove oil fill cap/dipstick. Be careful not to allow dirt to enter the engine when changing oil.
- Remove drain plug.
- After oil has drained completely, replace oil drain plug and tighten securely.
- Refill engine with oil through oil fill dipstick tube. Pour slowly. Do not overfill. For approximate capacity see "PRODUCT SPECIFICATIONS" on page 5 of this manual.
- Use gauge on oil fill cap/dipstick for checking level. Be sure dipstick cap is tightened securely for accurate reading. Keep oil at "FULL" line on dipstick.

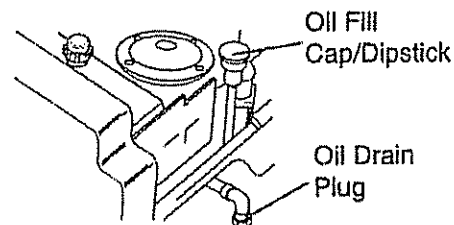

### AIR FILTER

Your engine will not run properly using a dirty air filter. Clean the foam pre-cleaner after every 25 hours of operation or every season. Service paper cartridge every 100 hours of operation or every season, whichever occurs first.

Service air cleaner more often under dusty conditions.

- Remove knob(s) and cover.

#### TO SERVICE PRE-CLEANER

- Slide foam pre-cleaner off cartridge.
- Wash it in liquid detergent and water.
- Squeeze it dry in a clean cloth.
- Saturate it in engine oil. Wrap it in clean, absorbent cloth and squeeze to remove excess oil.
- If very dirty or damaged, replace pre-cleaner.
- Reinstall pre-cleaner over cartridge.
- Reinstall cover and secure with knob(s).

#### TO SERVICE CARTRIDGE

- Remove cartridge nut.
- Carefully remove cartridge to prevent debris from entering carburetor. Clean base carefully to prevent debris from entering carburetor.
- Clean cartridge by tapping gently on flat surface. If very dirty or damaged, replace cartridge.

- Reinstall cartridge, nut, precleaner, cover and secure with knob(s).
- IMPORTANT:** Petroleum solvents, such as kerosene, are not to be used to clean the cartridge. They may cause deterioration of the cartridge. Do not oil cartridge. Do not use pressurized air to clean or dry cartridge.

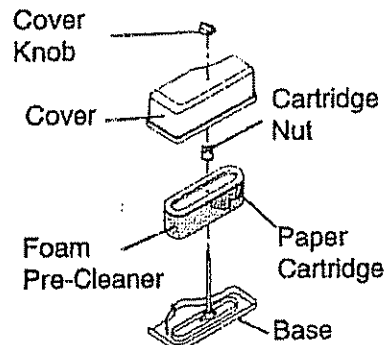

### CLEAN AIR SCREEN

Air screen must be kept free of dirt and chaff to prevent engine damage from overheating. Clean with a wire brush or compressed air to remove dirt and stubborn dried gum fibers.

### ENGINE COOLING FINS

Remove any dust, dirt or oil from engine cooling fins to prevent engine damage from overheating.

- Remove screws from blower housing and lift housing and dipstick tube assembly off engine.
- Cover oil fill opening to prevent entry of dirt.
- Use compressed air or stiff bristle brush to thoroughly clean engine cooling fins.
- To reassemble, reverse above procedure.

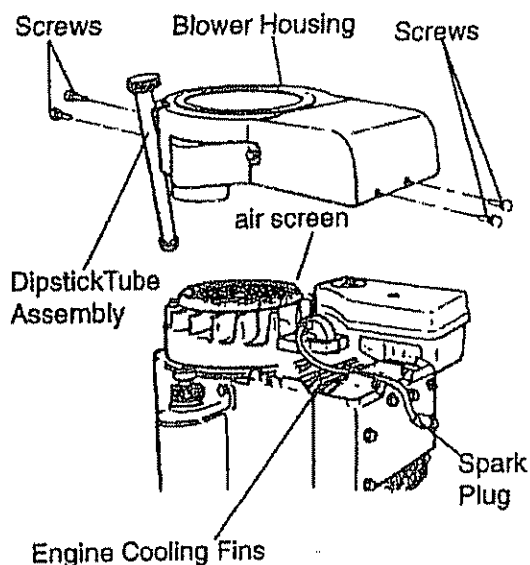

### MUFFLER

Inspect and replace corroded muffler and spark arrester (if equipped) as it could create a fire hazard and/or damage.

### SPARK PLUGS

Replace spark plugs at the beginning of each mowing season or after every 100 hours of operation, whichever occurs first. Spark plug type and gap setting are shown in "PRODUCT SPECIFICATIONS" on page 5 of this manual.

### IN-LINE FUEL FILTER

The fuel filter should be replaced once each season. If fuel filter becomes clogged, obstructing fuel flow to carburetor, replacement is required.

- With engine cool, remove filter and plug fuel line sections.
- Place new fuel filter in position in fuel line with arrow pointing towards carburetor.
- Be sure there are no fuel line leaks and clam.

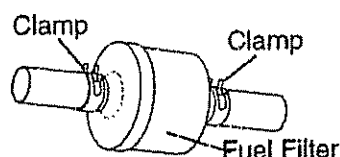

### CLEANING

- Clean engine, battery, seat, finish, etc. of all foreign matter.
- Keep finished surfaces and wheels free of all gasoline, oil, etc.
- Protect painted surfaces with automotive type wax.

We do not recommend using a garden hose to clean your tractor unless the electrical system, muffler, air filter and carburetor are covered to keep water out. Water in engine can result in a shortened engine life.

## SERVICE AND ADJUSTMENTS

**▲ CAUTION:** Before performing any service or adjustments:

- Depress clutch/brake pedal fully and set parking brake.
- Place gearshift lever in neutral (N) position.
- Place attachment clutch in "DISENGAGED" position.
- Turn ignition key "OFF" and remove key.
- Make sure the blades and all moving parts have completely stopped.
- Disconnect spark plug wire from spark plug and place wire where it cannot come in contact with plug.

### TO REMOVE MOWER

Mower will be easier to remove from the right side of tractor.

- Place attachment clutch in "DISENGAGED" position.
- Move attachment lift lever forward to lower mower to its lowest position.
- Roll belt off engine pulley.
- Disconnect clutch rod from clutch lever by removing retainer spring.
- Disconnect anti-swaybar from chassis bracket by removing retainer spring.
- Disconnect suspension arms from rear deck brackets by removing retainer springs.

- Disconnect front links from deck by removing retainer springs.
- Raise lift lever to raise suspension arms. Slide mower out from under tractor.

**IMPORTANT:** If an attachment other than the mower deck is to be mounted on the tractor, remove the front links.

### TO INSTALL MOWER

- Raise attachment lift lever to its highest position.
- Slide mower under tractor with discharge guard to right side of tractor.
- Lower lift lever to its lowest position.
- Install mower in reverse order of removal instructions.

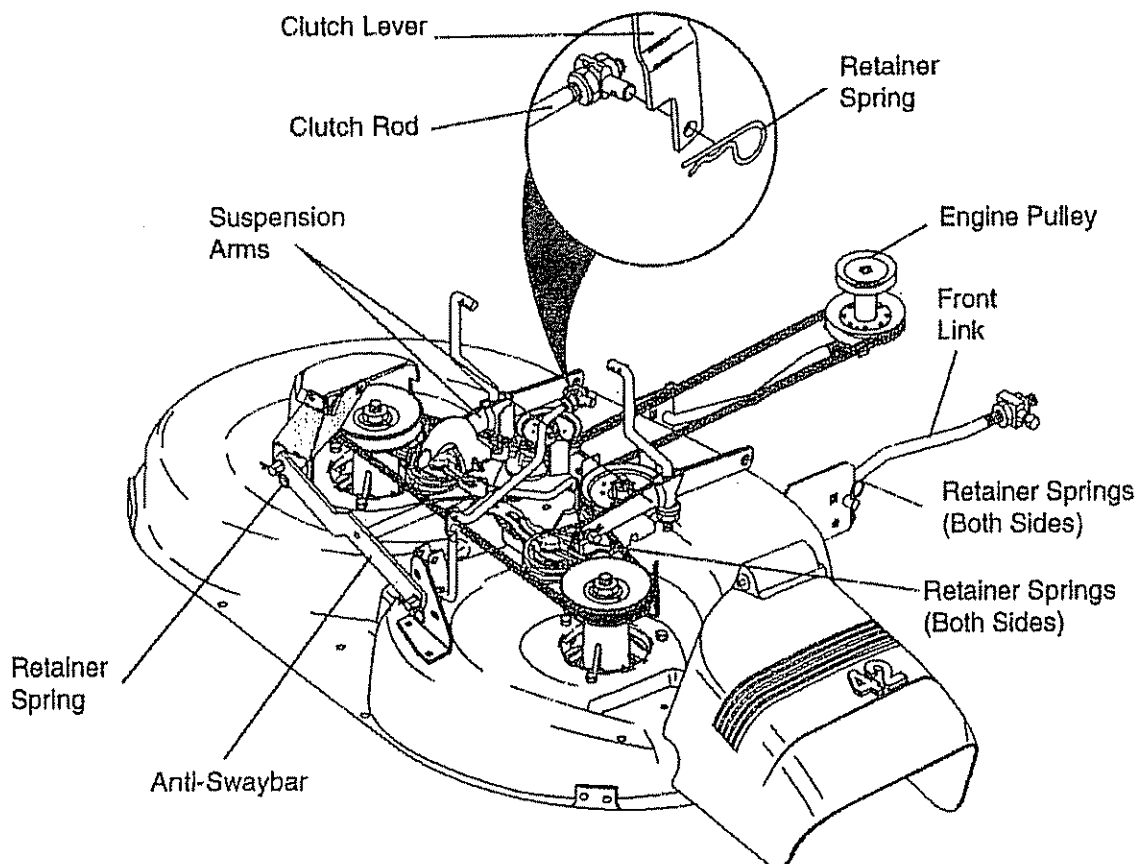

## TO LEVEL MOWER HOUSING

Adjust the mower while tractor is parked on level ground or driveway. Make sure tires are properly inflated (See "PRODUCT SPECIFICATIONS"). If tires are over or underinflated, you will not properly adjust your mower.

## SIDE-TO-SIDE ADJUSTMENT

- Raise mower to its highest position.
- At the midpoint of both sides of mower, measure height from bottom edge of mower to ground. Distance "A" on both sides of mower should be the same or within 1/4" of each other.
- If adjustment is necessary, make adjustment on one side of mower only.
- To raise one side of mower, tighten lift link adjustment nut on that side.
- To lower one side of mower, loosen lift link adjustment nut on that side.

**NOTE:** Each full turn of adjustment nut will change mower height about 1/8".

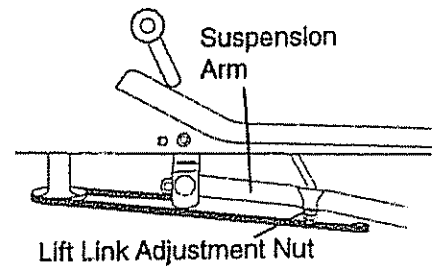
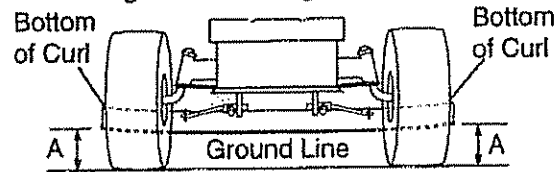

- Recheck measurements after adjusting.

## FRONT-TO-BACK ADJUSTMENT

**IMPORTANT:** Deck must be level side-to-side. If the following front-to-back adjustment is necessary, be sure to adjust both front links equally so mower will stay level side-to-side.

To obtain the best cutting results, the mower housing should be adjusted so that the front is approximately 1/8" to 1/2" lower than the rear when the mower is in its highest position.

Check adjustment on right side of tractor. Measure distance "D" directly in front and behind the mandrel at bottom edge of mower housing as shown.

- Before making any necessary adjustments, check that both front links are

equal in length. Both links should be approximately 10-3/8".

- If links are not equal in length, adjust one link to same length as other link.
- To lower front of mower loosen nut "E" on both front links an equal number of turns.
- When distance "D" is 1/8" to 1/2" lower at front than rear, tighten nuts "F" against trunnion on both front links.
- To raise front of mower, loosen nut "F" from trunnion on both front links. Tighten nut "E" on both front links an equal number of turns.
- When distance "D" is 1/8" to 1/2" lower at front than rear, tighten nut "F" against trunnion on both front links.
- Recheck side-to-side adjustment.

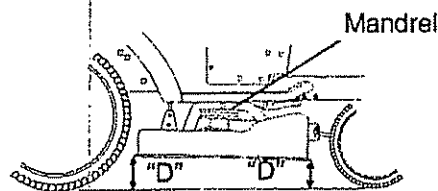

Both Front Links Should be Equal in Length

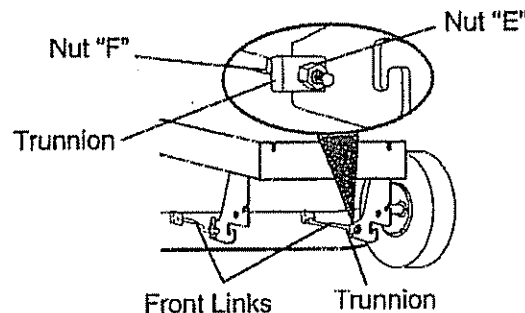
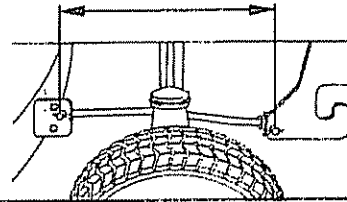

## TO REPLACE MOWER BLADE DRIVE BELT (See Illustration Next Page)

The mower blade drive belt may be replaced without tools. Park the tractor on level surface. Engage parking brake.

### BELT REMOVAL -

- Remove mower from tractor (See "TO REMOVE MOWER" in this section of this manual).
- Work belt off both mandrel pulleys and idler pulleys.
- Pull belt away from mower.

## BELT INSTALLATION -

- Install new belt in reverse order of removal.

- Make sure belt is in all pulley grooves and inside all belt guides.
- Install mower in reverse order of removal instructions.

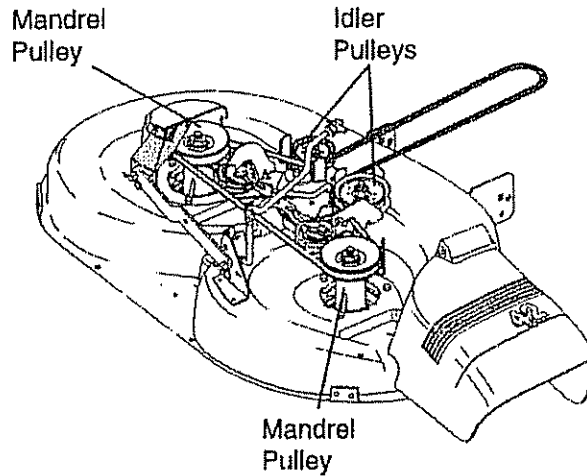

## TO ADJUST BRAKE

Your tractor is equipped with an adjustable brake system which is mounted on the right side of the transaxle.

If tractor requires more than six (6) feet stopping distance at high speed in highest gear, then brake must be adjusted.

- Depress clutch/brake pedal and engage parking brake.
- Measure distance between brake operating arm and nut "A" on brake rod.
- If distance is other than 1-1/2", loosen jam nut and turn nut "A" until distance becomes 1-1/2". Retighten jam nut against nut "A".
- Road test tractor for proper stopping distance as stated above. Readjust if necessary. If stopping distance is still greater than six (6) feet in highest gear, further maintenance is necessary. Contact your nearest authorized service center.

## TO REPLACE MOTION DRIVE BELT

Park the tractor on level surface. Engage parking brake. For assistance, there is a belt installation guide decal on bottom side of left footrest.

- Remove mower (See "TO REMOVE MOWER" in this section of this manual.)
- Remove upper belt keeper.
- Remove belt from stationary idler and clutching idler.
- Pull belt slack toward rear of tractor. Remove belt upwards from transaxle pulley by deflecting belt keepers.
- Pull belt toward front of tractor and remove downwards from around engine pulley.
- Install new belt by reversing above procedure.

**IMPORTANT:** Make sure upper belt keeper is positioned properly between locator tab.

With Parking Brake "Engaged"

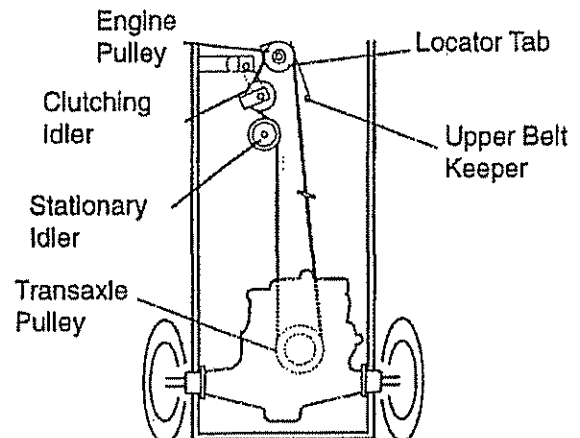
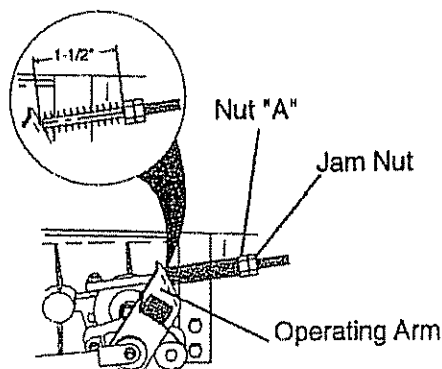

## TO ADJUST STEERING WHEEL ALIGNMENT

If steering wheel crossbars are not horizontal (left to right) when wheels are positioned straight forward, remove steering wheel and reassemble per instructions in the Assembly section of this manual.

## FRONT WHEEL TOE-IN/CAMBER

The front wheel toe-in and camber are not adjustable on your tractor. If damage has occurred to affect the front wheel toe-in or camber, contact your nearest authorized service center.

## TO REMOVE WHEEL FOR REPAIRS

- Block up axle securely.
- Remove axle cover, retaining ring and washers to allow wheel removal (rear wheel contains a square key - Do not lose).
- Repair tire and reassemble.
- On rear wheels only: align grooves in rear wheel hub and axle. Insert square key.
- Replace washers and snap retaining ring securely in axle groove.
- Replace axle cover.

**NOTE:** To seal tire punctures and prevent flat tires due to slow leaks, tire sealant may be purchased from your local parts dealer. Tire sealant also prevents tire dry rot and corrosion.

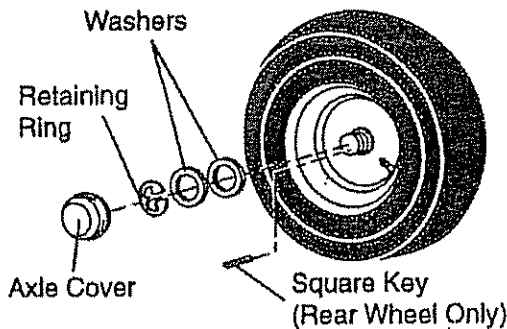

## TO START ENGINE THAT HAS A WEAK BATTERY

**CAUTION:** Lead-acid batteries generate explosive gases. Keep sparks, flame and smoking materials away from batteries. Always wear eye protection when around batteries.

If your battery is too weak to start the engine, it should be recharged. If "jumper cables" are used for emergency starting, follow this procedure:

**IMPORTANT:** Your tractor is equipped with a 12 volt negative grounded system.

The other vehicle must also be a 12 volt negative grounded system. Do not use your tractor battery to start other vehicles.

## TO ATTACH JUMPER CABLES -

- Connect each end of the RED cable to the POSITIVE (+) terminal of each battery, taking care not to short against chassis.
- Connect one end of the BLACK cable to the NEGATIVE (-) terminal of fully charged battery.
- Connect the other end of the BLACK cable to good CHASSIS GROUND, away from fuel tank and battery.

## TO REMOVE CABLES, REVERSE ORDER -

- Remove BLACK cable first from chassis and then from the fully charged battery.
- Remove RED cable last from both batteries.

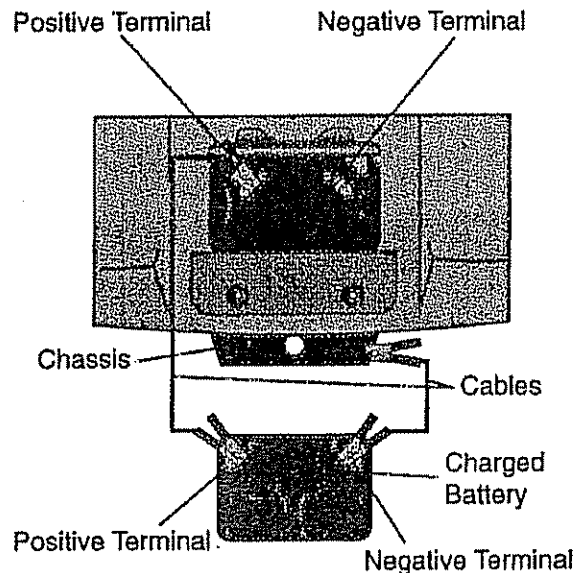



### TO REPLACE HEADLIGHT BULB

- Raise hood.
- Pull bulb holder out of the hole in the backside of the grill.
- Replace bulb in holder and push bulb holder securely back into the hole in the backside of the grill.
- Close hood.

### INTERLOCKS AND RELAYS

Loose or damaged wiring may cause your tractor to run poorly, stop running, or prevent it from starting.

- Check wiring. See electrical wiring diagram in the Repair Parts section of this manual.

### TO REPLACE FUSE

Replace with 30 amp automotive-type plug-in fuse. The fuse holder is located behind the dash.

### TO REMOVE HOOD AND GRILL ASSEMBLY

- Raise hood.
- Unsnap headlight wire connector.
- Stand in front of tractor. Grasp hood at sides, tilt toward engine and lift off of tractor.
- To replace, reverse above procedures.

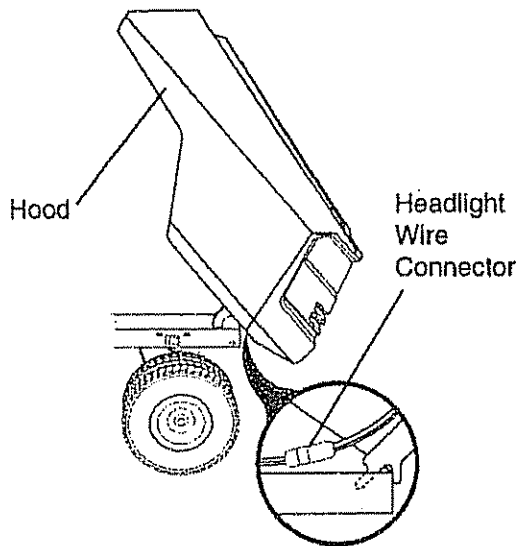

### ENGINE

Maintenance, repair, or replacement of the emission control devices and systems, which are being done at the customer's expense, may be performed by any non-road engine repair establishment or individual. Warranty repairs must be performed by an authorized engine manufacturer's service outlet.

### TO ADJUST THROTTLE CONTROL CABLE

The throttle control has been preset at the factory and adjustment should not be necessary. Check adjustment as described below before loosening cable. If adjustment is necessary, proceed as follows:

- With engine not running, move throttle control lever from slow to choke position. Slowly move lever from choke to fast position.
- Check that holes "A" in governor control lever and hole in governor plate line-up. If holes "A" are not aligned, loosen clamp screw and move throttle cable until holes are aligned. Tighten clamp screw securely.

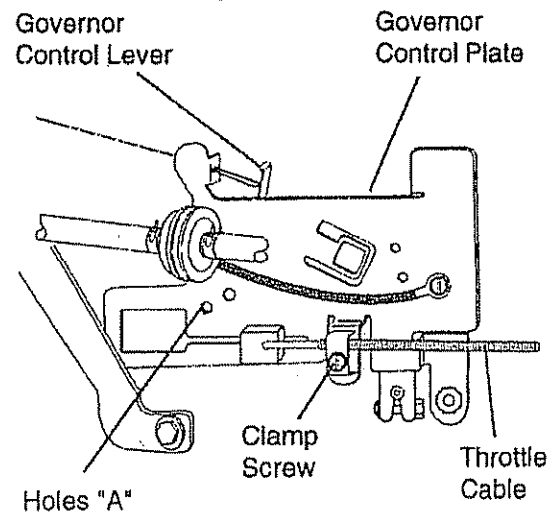

## TO ADJUST CARBURETOR

**NOTE:** The carburetor on this engine is low emission. It is equipped with an idle fuel adjusting needle with a limiter cap, which allows some adjustment within the limits allowed by the cap. Do not attempt to remove the limiter cap. The limiter cap cannot be removed without breaking the adjusting needle.

The carburetor has been preset at the factory and adjustment should not be necessary. However, minor adjustment may be required to compensate for differences in fuel, temperature, altitude or load. If the carburetor does need adjustment, proceed as follows:

In general, turning idle mixture valve **in** (clockwise) decreases the supply of fuel to the engine giving a leaner fuel/air mixture. Turning the idle mixture valve **out** (counterclockwise) increases the supply of fuel to the engine giving a richer fuel/air mixture.

**IMPORTANT:** Damage to the needle valve and the seat in carburetor may result if screw is turned in too tight.

### PRELIMINARY SETTING -

- Air cleaner assembly must be assembled to the carburetor when making carburetor adjustments.
- Be sure the throttle control cable is adjusted properly (see above).

### FINAL SETTING -

- Start engine and allow to warm for five minutes. Make final adjustments with engine running and shift/motion control lever in neutral (N) position.
- Move throttle control lever to slow position. With finger, rotate and hold throttle lever against idle speed screw. Turn idle speed screw to attain 1750 RPM.

- While still holding throttle lever against idle speed screw, turn idle mixture valve full travel clockwise then counterclockwise until engine runs rough. Turn valve to a point midway between those two positions. Release throttle lever.

### ACCELERATION TEST -

- Move throttle control lever from slow to fast position. If engine hesitates or dies, turn idle mixture valve **out** (counterclockwise) 1/8 turn. Repeat test and continue to adjust, if necessary, until engine accelerates smoothly.

High speed stop is factory adjusted. Do not adjust—damage may result.

**IMPORTANT:** Never tamper with the engine governor, which is factory set for proper engine speed. Overspeeding the engine above the factory high speed setting can be dangerous. If you think the engine-governed high speed needs adjusting, contact your nearest authorized service center, which has proper equipment to make any necessary adjustments.

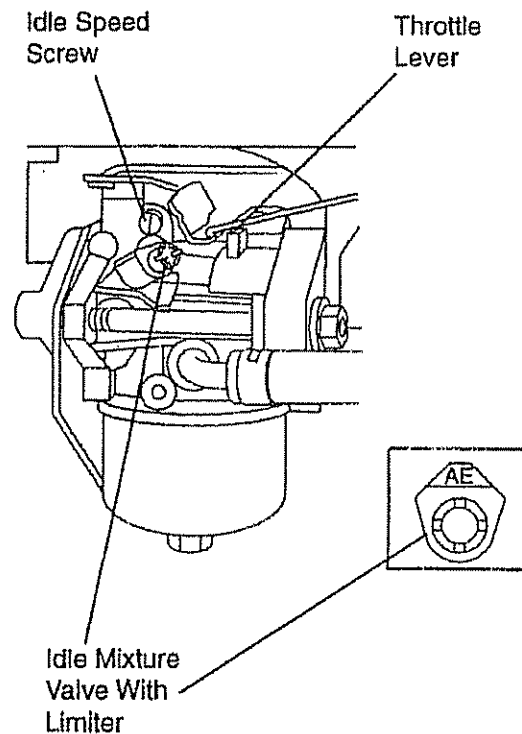

## STORAGE

Immediately prepare your tractor for storage at the end of the season or if the tractor will not be used for 30 days or more.

**▲CAUTION:** Never store the tractor with gasoline in the tank inside a building where fumes may reach an open flame or spark. Allow the engine to cool before storing in any enclosure.

### TRACTOR

Remove mower from tractor for winter storage. This will allow you to clean it thoroughly. Remove all dirt, grease, leaves, etc. Store in a clean, dry area.

- Clean entire tractor (See "CLEANING" in the Maintenance section of this manual).
- Inspect and replace belts, if necessary (See belt replacement instructions in the Service and Adjustments section of this manual).
- Lubricate as shown in the Maintenance section of this manual.
- Be sure that all nuts, bolts and screws are securely fastened. Inspect moving parts for damage, breakage and wear. Replace if necessary.
- Touch up all rusted or chipped paint surfaces; sand lightly before painting.

### BATTERY

- Fully charge the battery for storage.
- After a period of time in storage, battery may require recharging.
- To help prevent corrosion and power leakage during long periods of storage, battery cables should be disconnected and battery cleaned thoroughly (see "TO CLEAN BATTERY AND TERMINALS" in the Maintenance section of this manual).
- After cleaning, leave cables disconnected and place cables where they cannot come in contact with battery terminals.
- If battery is removed from tractor for storage, do not store battery directly on concrete or damp surfaces.

### ENGINE

#### FUEL SYSTEM

**IMPORTANT:** It is important to prevent gum deposits from forming in essential fuel system parts such as carburetor, fuel filter, fuel hose, or tank during storage. Also, experience indicates that alcohol blended

fuels (called gasohol or using ethanol or methanol) can attract moisture which leads to separation and formation of acids during storage. Acidic gas can damage the fuel system of an engine while in storage.

- Drain the fuel tank.
- Start the engine and let it run until the fuel lines and carburetor are empty.
- Never use engine or carburetor cleaner products in the fuel tank or permanent damage may occur.
- Use fresh fuel next season.

**NOTE:** Fuel stabilizer is an acceptable alternative in minimizing the formation of fuel gum deposits during storage. Add stabilizer to gasoline in fuel tank or storage container. Always follow the mix ratio found on stabilizer container. Run engine at least 10 minutes after adding stabilizer to allow the stabilizer to reach the carburetor. Do not drain the gas tank and carburetor if using fuel stabilizer.

#### ENGINE OIL

Drain oil (with engine warm) and replace with clean engine oil. (See "ENGINE" in the Maintenance section of this manual).

#### CYLINDER

- Remove spark plug(s).
- Pour one ounce of oil through spark plug hole(s) into cylinder(s).
- Turn ignition key to "START" position for a few seconds to distribute oil.
- Replace with new spark plug(s).

#### OTHER

- Do not store gasoline from one season to another.
- Replace your gasoline can if it starts to rust. Rust and/or dirt in your gasoline will cause problems.
- If possible, store your tractor indoors and cover it to give protection from dust and dirt.
- Cover your tractor with a suitable protective cover that does not retain moisture. Do not use plastic. Plastic cannot breathe, which allows condensation to form and cause your tractor to rust.

**IMPORTANT:** Never cover tractor while engine and exhaust areas are still warm.

## TROUBLESHOOTING CHART

PROBLEM	CAUSE	CORRECTION
Will not start	<ul style="list-style-type: none"> <li>• Out of fuel.</li> <li>• Engine not "CHOKED" properly.</li> <li>• Engine flooded.</li>   <li>• Bad spark plug.</li> <li>• Dirty air filter.</li> <li>• Dirty fuel filter.</li> <li>• Water in fuel.</li>   <li>• Loose or damaged wiring.</li> <li>• Carburetor out of adjustment.</li>   <li>• Engine valves out of adjustment.</li> </ul>	<ul style="list-style-type: none"> <li>• Fill fuel tank.</li> <li>• See "TO START ENGINE" in Operation section.</li> <li>• Wait several minutes before attempting to start.</li> <li>• Replace spark plug.</li> <li>• Clean/replace air filter.</li> <li>• Replace fuel filter.</li> <li>• Drain fuel tank and carburetor, refill tank with fresh gasoline and replace fuel filter.</li> <li>• Check all wiring.</li> <li>• See "To Adjust Carburetor" in Service and Adjustments section.</li> <li>• Contact an authorized service center.</li> </ul>
Hard to start	<ul style="list-style-type: none"> <li>• Dirty air filter.</li> <li>• Bad spark plug.</li> <li>• Weak or dead battery.</li> <li>• Dirty fuel filter.</li> <li>• Stale or dirty fuel.</li>   <li>• Loose or damaged wiring.</li> <li>• Carburetor out of adjustment.</li>   <li>• Engine valves out of adjustment.</li> </ul>	<ul style="list-style-type: none"> <li>• Clean/replace air filter.</li> <li>• Replace spark plug.</li> <li>• Recharge or replace battery.</li> <li>• Replace fuel filter.</li> <li>• Drain fuel tank and refill with fresh gasoline.</li> <li>• Check all wiring.</li> <li>• See "To Adjust Carburetor" in Service and Adjustments section.</li> <li>• Contact an authorized service center.</li> </ul>
Engine will not turn over	<ul style="list-style-type: none"> <li>• Clutch/brake pedal not depressed.</li> <li>• Attachment clutch is engaged.</li> <li>• Weak or dead battery.</li> <li>• Blown fuse.</li> <li>• Corroded battery terminals.</li> <li>• Loose or damaged wiring.</li> <li>• Faulty ignition switch.</li>   <li>• Faulty solenoid or starter.</li>   <li>• Faulty operator presence switch(es).</li> </ul>	<ul style="list-style-type: none"> <li>• Depress clutch/brake pedal.</li>   <li>• Disengage attachment clutch.</li> <li>• Recharge or replace battery.</li> <li>• Replace fuse.</li> <li>• Clean battery terminals.</li>   <li>• Check all wiring.</li> <li>• Check/replace ignition switch.</li> <li>• Check/replace solenoid or starter.</li> <li>• Contact an authorized service center.</li> </ul>
Engine clicks but will not start	<ul style="list-style-type: none"> <li>• Weak or dead battery.</li> <li>• Corroded battery terminals.</li> </ul>	<ul style="list-style-type: none"> <li>• Recharge or replace battery.</li> <li>• Clean battery terminals.</li> </ul>

## TROUBLESHOOTING CHART

PROBLEM	CAUSE	CORRECTION
Engine clicks but will not start (cont'd)	<ul style="list-style-type: none"> <li>• Loose or damaged wiring.</li> <li>• Faulty solenoid or starter.</li> </ul>	<ul style="list-style-type: none"> <li>• Check all wiring.</li> <li>• Check/replace solenoid or starter.</li> </ul>
Loss of power	<ul style="list-style-type: none"> <li>• Cutting too much grass/too fast.</li> <li>• Throttle in "CHOKE" position.</li> <li>• Build-up of grass, leaves and trash under mower.</li> <li>• Dirty air filter.</li> <li>• Low oil level/dirty oil.</li> <li>• Faulty spark plug.</li>   <li>• Dirty fuel filter.</li> <li>• Stale or dirty fuel.</li>   <li>• Water in fuel.</li>   <li>• Spark plug wire loose.</li>   <li>• Dirty engine air screen/fins.</li> <li>• Dirty/clogged muffler.</li> <li>• Loose or damaged wiring.</li> <li>• Carburetor out of adjustment.</li>   <li>• Engine valves out of adjustment.</li> </ul>	<ul style="list-style-type: none"> <li>• Set in "Higher Cut" position/reduce speed.</li> <li>• Adjust throttle control.</li>   <li>• Clean underside of mower housing.</li> <li>• Clean/replace air filter.</li> <li>• Check oil level/change oil.</li> <li>• Clean and regap or change spark plug.</li> <li>• Replace fuel filter.</li> <li>• Drain fuel tank and refill with fresh gasoline.</li> <li>• Drain fuel tank and carburetor, refill tank with fresh gasoline and replace fuel filter.</li> <li>• Connect and tighten spark plug wire.</li> <li>• Clean engine air screen/fins.</li>   <li>• Clean/replace muffler.</li> <li>• Check all wiring.</li> <li>• See "To Adjust Carburetor" in Service and Adjustments section.</li> <li>• Contact an authorized service center.</li> </ul>
Excessive vibration	<ul style="list-style-type: none"> <li>• Worn, bent or loose blade.</li> <li>• Bent blade mandrel.</li> <li>• Loose/damaged part(s).</li> </ul>	<ul style="list-style-type: none"> <li>• Replace blade. Tighten blade bolt.</li> <li>• Replace blade mandrel.</li> <li>• Tighten loose part(s). Replace damaged parts.</li> </ul>
Engine continues to run when operator leaves seat with attachment clutch engaged	<ul style="list-style-type: none"> <li>• Faulty operator-safety presence control system.</li> </ul>	<ul style="list-style-type: none"> <li>• Check wiring, switches and connections. If not corrected, contact an authorized service center.</li> </ul>
Poor cut - uneven	<ul style="list-style-type: none"> <li>• Worn, bent or loose blade.</li> <li>• Mower deck not level.</li> <li>• Buildup of grass, leaves, and trash under mower.</li> <li>• Bent blade mandrel.</li> <li>• Clogged mower deck vent holes from buildup of</li> </ul>	<ul style="list-style-type: none"> <li>• Replace blade. Tighten blade bolt.</li> <li>• Level mower deck.</li> <li>• Clean underside of mower housing.</li> <li>• Replace blade mandrel.</li> <li>• Clean around mandrels to open vent holes.</li> </ul>

## TROUBLESHOOTING CHART

PROBLEM	CAUSE	CORRECTION
Poor cut - uneven (cont'd)	grass, leaves, and trash around mandrels.	
Mower blades will not rotate	<ul style="list-style-type: none"> <li>• Obstruction in clutch mechanism.</li> <li>• Worn/damaged mower drive belt.</li> <li>• Frozen idler pulley.</li> <li>• Frozen blade mandrel.</li> </ul>	<ul style="list-style-type: none"> <li>• Remove obstruction.</li> <li>• Replace mower drive belt.</li> <li>• Replace idler pulley.</li> <li>• Replace blade mandrel.</li> </ul>
Poor grass discharge	<ul style="list-style-type: none"> <li>• Engine speed too slow.</li> <li>• Travel speed too fast.</li> <li>• Wet grass.</li> <li>• Mower deck not level.</li> <li>• Low/uneven tire air pressure.</li> <li>• Worn, bent or loose blade.</li> <li>• Buildup of grass, leaves and trash under mower.</li> <li>• Mower drive belt worn.</li> <li>• Blades improperly installed.</li> <li>• Improper blades used.</li> <li>• Clogged mower deck vent holes from buildup of grass, leaves, and trash around mandrels.</li> </ul>	<ul style="list-style-type: none"> <li>• Place throttle control in "FAST" position.</li> <li>• Shift to slower speed.</li> <li>• Allow grass to dry before mowing.</li> <li>• Level mower deck.</li> <li>• Check tires for proper air pressure.</li> <li>• Replace/sharpen blade.</li> <li>• Tighten blade bolt.</li> <li>• Clean underside of mower housing.</li> <li>• Replace mower drive belt.</li> <li>• Reinstall blades sharp edge down.</li> <li>• Replace with blades listed in this manual.</li> <li>• Clean around mandrels to open vent holes.</li> </ul>
Headlight(s) not working (if so equipped)	<ul style="list-style-type: none"> <li>• Switch is "OFF".</li> <li>• Bulb(s) burned out.</li> <li>• Faulty light switch.</li> <li>• Loose or damaged wiring.</li> <li>• Blown fuse.</li> </ul>	<ul style="list-style-type: none"> <li>• Turn switch "ON".</li> <li>• Replace bulb(s).</li> <li>• Check/replace light switch.</li> <li>• Check wiring and connections.</li> <li>• Replace fuse.</li> </ul>
Battery will not charge	<ul style="list-style-type: none"> <li>• Bad battery cell(s).</li> <li>• Poor cable connections.</li> <li>• Faulty regulator (if so equipped).</li> <li>• Faulty alternator.</li> </ul>	<ul style="list-style-type: none"> <li>• Replace battery.</li> <li>• Check/clean all connections.</li> <li>• Replace regulator.</li> <li>• Replace alternator.</li> </ul>
Engine "backfires" when turning engine "OFF"	<ul style="list-style-type: none"> <li>• Engine throttle control not set at "SLOW" position for 30 seconds before stopping engine.</li> </ul>	<ul style="list-style-type: none"> <li>• Move throttle control to "SLOW" position and allow to idle for 30 seconds before stopping engine.</li> </ul>







# TRACTOR - - MODEL NUMBER 917.270411

## SCHEMATIC

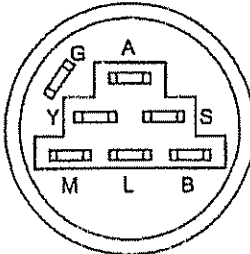
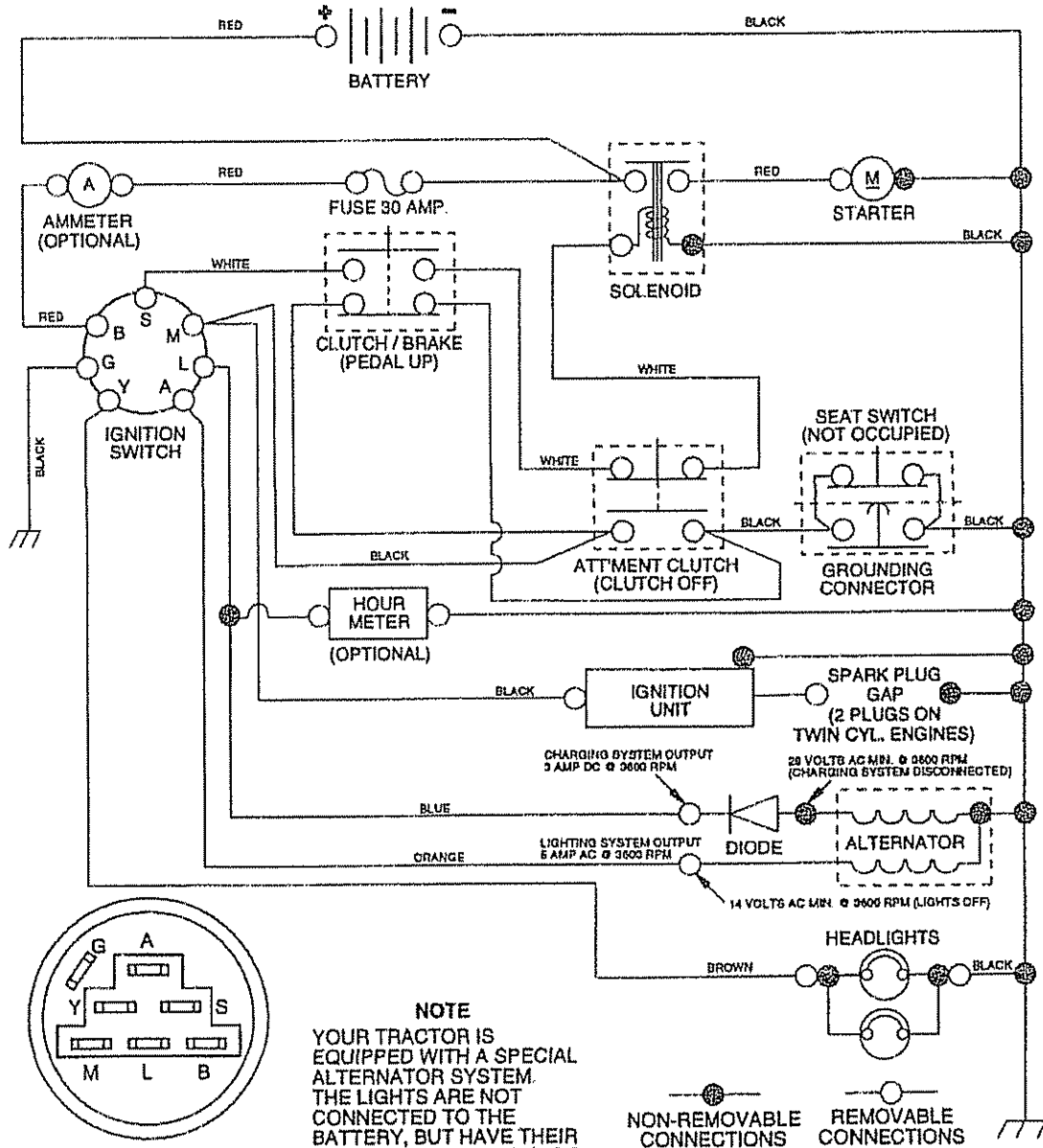

**IGNITION SWITCH**

POSITION	CIRCUIT	"MAKE"
OFF	G + M + L	NONE
RUN/LIGHT	B + L	A + Y
RUN	B + L	NONE
START	B + L + S	NONE

**NOTE**  
 YOUR TRACTOR IS EQUIPPED WITH A SPECIAL ALTERNATOR SYSTEM. THE LIGHTS ARE NOT CONNECTED TO THE BATTERY, BUT HAVE THEIR OWN ELECTRICAL SOURCE. BECAUSE OF THIS, THE BRIGHTNESS OF THE LIGHTS WILL CHANGE WITH ENGINE SPEED. AT IDLE THE LIGHTS WILL DIM. AS THE ENGINE IS SPEEDED UP, THE LIGHTS WILL BECOME THEIR BRIGHTEST.

**WIRING INSULATED CLIPS**  
 NOTE: IF WIRING INSULATED CLIPS WERE REMOVED FOR SERVICING OF UNIT, THEY SHOULD BE REPLACED TO PROPERLY SECURE YOUR WIRING.

# REPAIR PARTS

TRACTOR -- MODEL NUMBER 917.270411

## ELECTRICAL

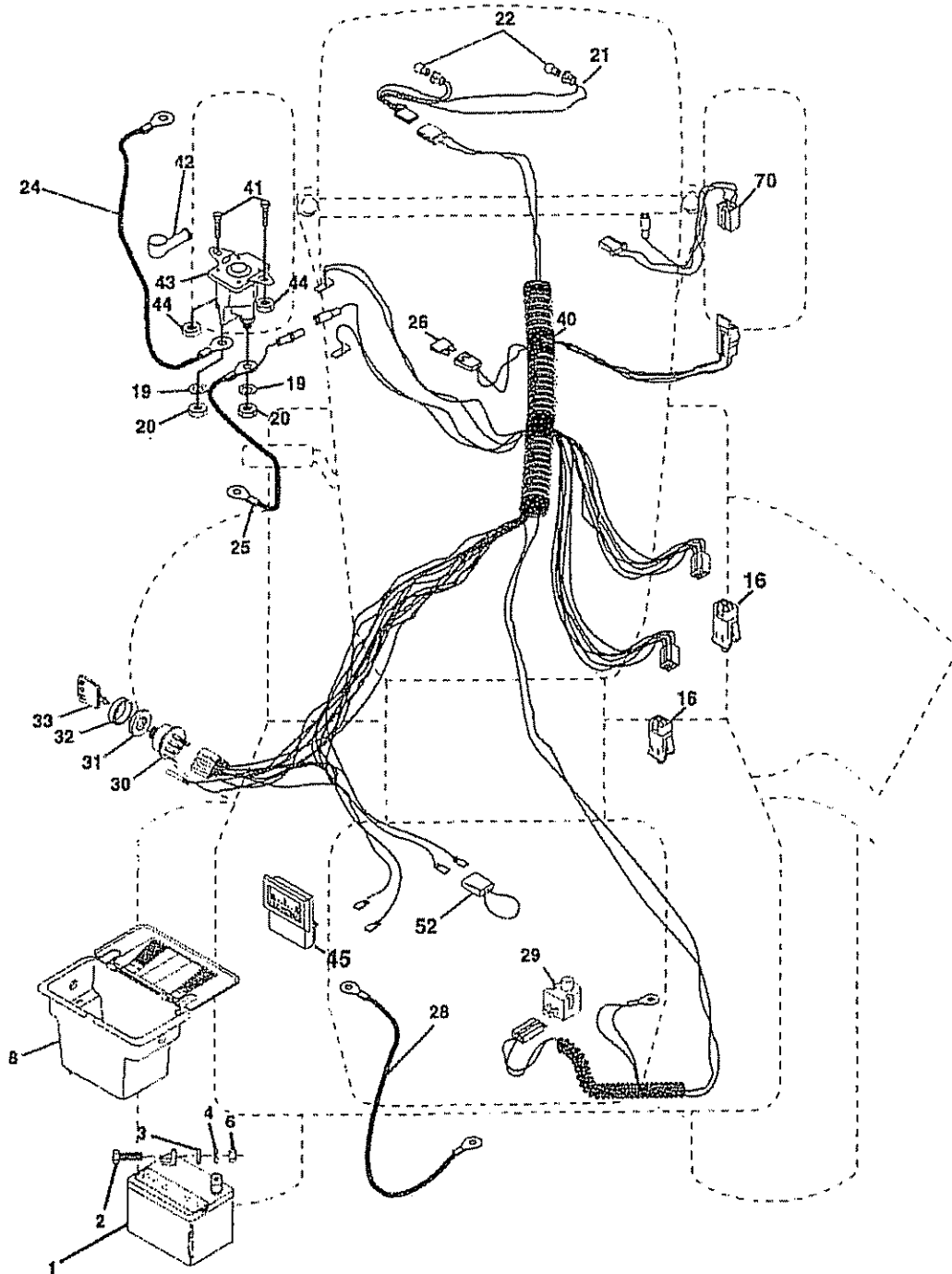

## ELECTRICAL

KEY NO.	PART NO.	DESCRIPTION
1	144925	Battery 12 Volt 25 Amp
2	74760412	Bolt, Hex Head 1/4-20 unc x 3/4
3	STD551025	Washer
4	STD551125	Washer
6	STD541025	Nut
8	156417	Case, Battery Mech Hinge
16	153664	Switch, Interlock Push-In
19	STD551125	Washer, Lock
20	73350400	Nut, Hex, Jam 1/4-20 UNC
21	136850	Harness, Light Socket (Includes 4152J)
22	4152J	Bulb, Light
24	4799J	Cable, Battery, 6 Gauge, Red, 11"
25	146147	Cable, Battery, 6 Gauge, Red, W/16 Wire
26	108824X	Fuse, 30 Amp
28	4207J	Cable, Ground, 6 Gauge, Black, 12"
29	121305X	Switch, Plunger
30	140301	Switch, Ignition
31	124211X	Nut, Ignition
32	141226	Cover, Key Switch
33	109310X	Key, Ignition
40	156442	Harness, Ignition
41	71110408	Bolt, Hex Head, Fin. 1/4-20 x 1/2
42	131563	Cover, Terminal, Red
43	145673	Solenoid
44	73640400	Nut Keps Blk Hex 1/4-20 UNC
45	121433X	Ammeter Rectangular 6 Amp
52	141940	Protection Wire Loop
70	140413	Harness Engine B&S

**NOTE:** All component dimensions give in U.S. Inches  
1 Inch = 25.4 mm

TRACTOR -- MODEL NUMBER 917.270411  
CHASSIS AND ENCLOSURES

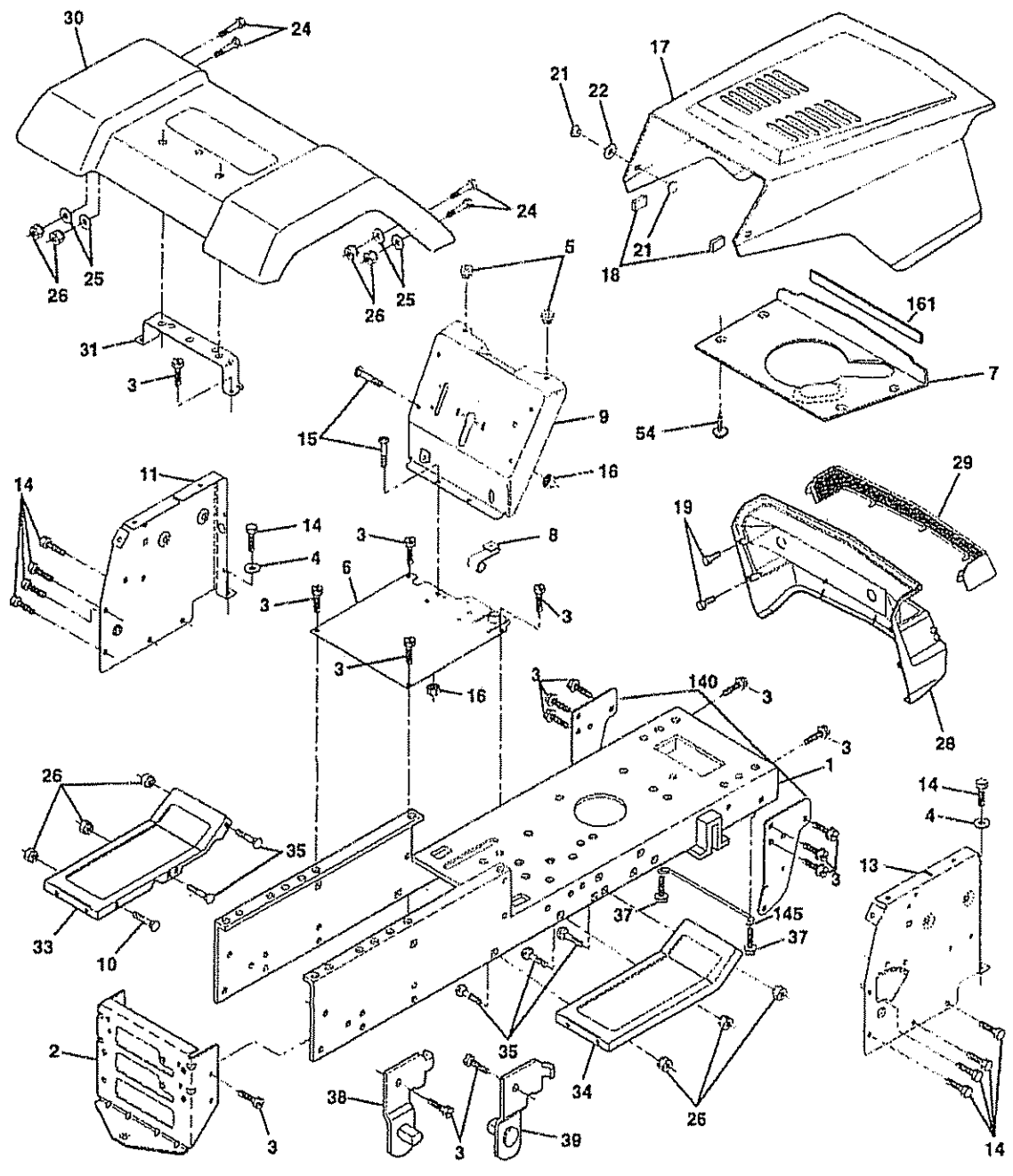

**TRACTOR - - MODEL NUMBER 917.270411**  
**CHASSIS AND ENCLOSURES**

KEY NO.	PART NO.	DESCRIPTION
1	160393	Chassis Asm. LT STMP
2	140356	Drawbar Stretch
3	17490612	Screw Thdrol 3/8-16 x 3/4 Ty-tt
4	STD551025	Washer 13/32 X 3/4 X 16 Ga
5	155272	Bumper Hood/Dash
6	155924X015	Saddle Slkscr Fit LT 6SP Dana
7	126842X	Shield Ht. Hood Lt
8	155138	Clip Retainer Slide-On
9	161914X012	Dash Slkscr 1-pc
10	STD533710	Bolt Rdhd Sqnk 3/8-16unc X 1
11	155927	Panel Dash LH
13	155934X010	Panel Slkscr Dash RH
14	17490608	Screw Thdrol 3/8-16 x 1/2 Ty-tt
15	74180512	Screw Mach TRHD 5/16-18 unc x 3/4
16	STD541431	Nut Keps 5/16-18 Unc
17	154988X558	Hood Asm
18	126938X	Bumper Hood
19	17521312	Screw Slt'd Hex Hd W/Pl Washer
21	122933X	Rivet Ratchet Nylon
22	124479X	Washer Nylon Blk 28 x 75 x 19
24	STD523710	Bolt Fin Hex 3/8-16 unc x 1 Gr. 5
25	19131312	Washer 13/32 X 13/16 x 12 Ga
26	STD541437	Nut Hex Lock W/Ins. 3/8-16 Unc
28	140137	Grille Black
29	124029X	Lens Headlight Bar Clear
30	157584X558	Fender Pnt LT W/o Shift
31	136619	Bracket Fender Repl 109873x
33	145244X558	Footrest Pnt Lh
34	145243X558	Footrest Pnt Rh
35	STD533707	Bolt Rdhd Sht Sqnk 3/8-16 x 3/4
37	17490508	Screw Thdrol 5/16-18 x 1/2
38	139886	Bracket Asm Pvt LH MWR Rear
39	139887	Bracket Asm Pvt RH MWR Rear
54	161464	Screw
140	158418	Bracket Suspension Front
145	156524	Rod Pivot Chassis/Hood
161	161547	Extrusion Hood
--	5479J	Plug Button Blk 359 Dia Choke

**NOTE:** All component dimensions give in U.S. inches  
1 inch = 25.4 mm

# TRACTOR -- MODEL NUMBER 917.270411

## GROUND DRIVE

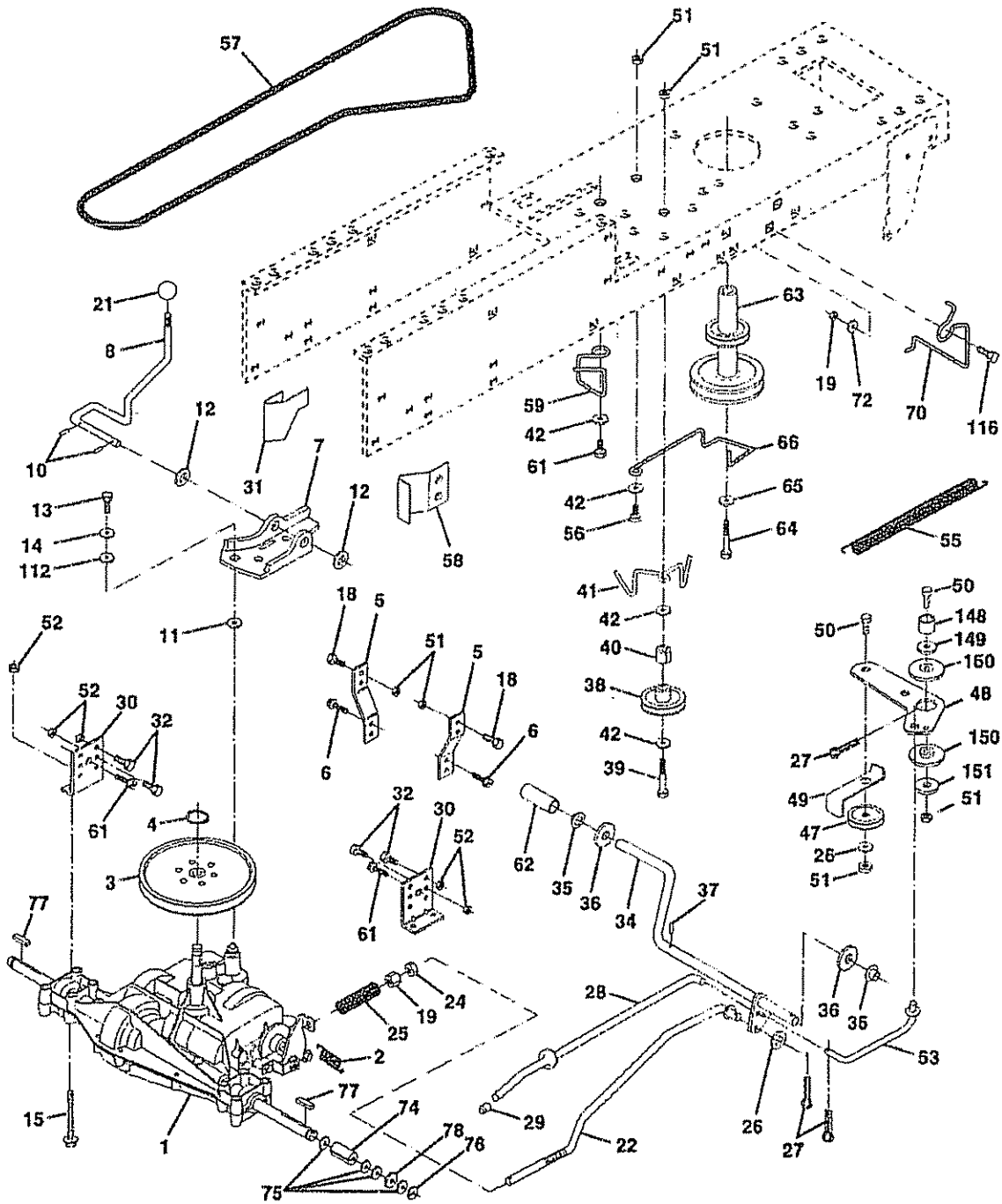

**TRACTOR - - MODEL NUMBER 917.270411**

**GROUND DRIVE**

<b>KEY NO.</b>	<b>PART NO.</b>	<b>DESCRIPTION</b>	<b>KEY NO.</b>	<b>PART NO.</b>	<b>DESCRIPTION</b>
1	-----	Transaxle Dana 4360-128 (See Breakdown)	41	154777	Keeper Belt Idler Fool Proof
2	146682	Spring Return Brake T/a Zinc	42	19131312	Washer 13/32 X 13/16 X 12 Ga
3	123666X	Pulley Transaxle 18/20" tires	47	127783	Pulley Idler V Groove Plastic
4	12000028	Ring Retainer # 5100-62	48	154407	Bellcrank Asm. Clutch
5	121520X	Strap Torque 30 Degrees	49	123205X	Retainer Belt Style Spring
6	17490512	Screw Thdrol 5/16-18 X 3/4 TYT	50	STD523715	Bolt Hex Hd 3/8-16unc X 1-1/2
		Bracket Saddle Shift T/a	51	STD541437	Nut Crownlock 3/8-16 UNC
7	162240	Bracket Saddle Shift T/a	52	STD541431	Nut Crown Lock 5/16-18
8	131679	Rod Shf Scl LY/YT Str Blk Zinc	53	105710X	Link Clutch 7 66
10	STD561210	Pin Cotter 1/8 X 1 Cad	55	105709X	Spring Return Clutch 6 75
11	105701X	Washer Plate Shf 388 Sq Hole	56	STD523712	Bolt Fin Hex 3/8-16 unc x 1-1/4
12	19151216	Washer 15/32 X 3/4 X 16ga	57	160855	V-Belt Gd Drive 95 25
13	74550412	Bolt 1/4-28unf Gr8 W/Patch	58	127274X	Keeper Belt RH LT Pnt/zinc 16g
14	STD551125	Washer Lock Hvy Helical 1/4	59	140312	Keeper Belt Centerspan
15	74490544	Bolt Hex FLGHD5/16-18Gr.5	61	17490612	Screw Thdrol 3/8-16x3/4 Ty-tt
18	STD523710	Bolt Fin Hex 3/8-16 UNC x 1 Gr. 5	62	8883R	Cover Pedal Blk Round
		Nut Lock Hex W/Ins. 3/8-16 Unc	63	140186	Pulley Eng Cl Mech 38deg LT/YT
19	STD541437	Nut Lock Hex W/Ins. 3/8-16 Unc	64	71170764	Bolt Hex 7/16-20x4 Gr 5
21	106933X	Knob Rd 1/2-13 Plstc Thds Blk	65	STD551143	Washer Lock Hvy Hlcl Spr 7/16
22	130804	Rod Brake Blk Zinc 26 840	66	154778	Keeper Belt Engine Fool Proof
24	STD541237	Nut Hex Jam 3/8-16 Unc	70	134683	Guide Belt Mower Drive RH
25	106888X	Spring Rod Brake 2 00 Zinc	72	19132012	Washer 13/32 X 1-1/4 X 12 Ga
26	STD551037	Washer 13/32 X 13/16 X 16 Ga	74	109502X	Spacer Axle
27	STD561210	Pin Cotter 1/8 X 3/4 Cad	75	121749X	Washer 25/32 X 1 1/4 X 16 Ga
28	145204	Rod Brake Parking Lt/Yt	76	STD581075	E-ring #5133-75
29	124236X	Cap Brake Parking Red	77	123583X	Key Square 2 0 X 1845/ 1865
30	130807	Bracket Mtg Transaxle	78	121748X	Washer 25/32 X 1-5/8 X 16ga
31	127275X	Keeper Belt LH LT 14 Ga	112	19091210	Washer 9/32 X 3/4 X 10 Ga
32	STD523107	Bolt Hex Hd 5/16-18unc X 3/4	116	72110610	Bolt Rdhd Sq Neck 3/8-16 x 1.25
34	155071	Shaft Asm Pedal Foot LT/STLT	148	159103	Spacer
35	120183X	Bearing Nylon Blk 629 Id	149	122052X	Spacer, Retainer Pm
36	STD551062	Washer 21/32 X 1 X 16 Ga	150	150935	Bushing, Nylon Collered
37	1572H	Pin Roll 3/16 X 1"	151	19133210	Washer 13/32 x 2 x 10 Ga.
38	123674X	Pulley Idler Flat			
39	STD523727	Bolt Fin Hex 3/8-16unc X 2-3/4	<b>NOTE:</b>	All component dimensions give in U.S. inches 1 inch = 25.4 mm	
40	4470J	Spacer Split 395 X 59 Bzp			

# TRACTOR - - MODEL NUMBER 917.270411

## STEERING ASSEMBLY

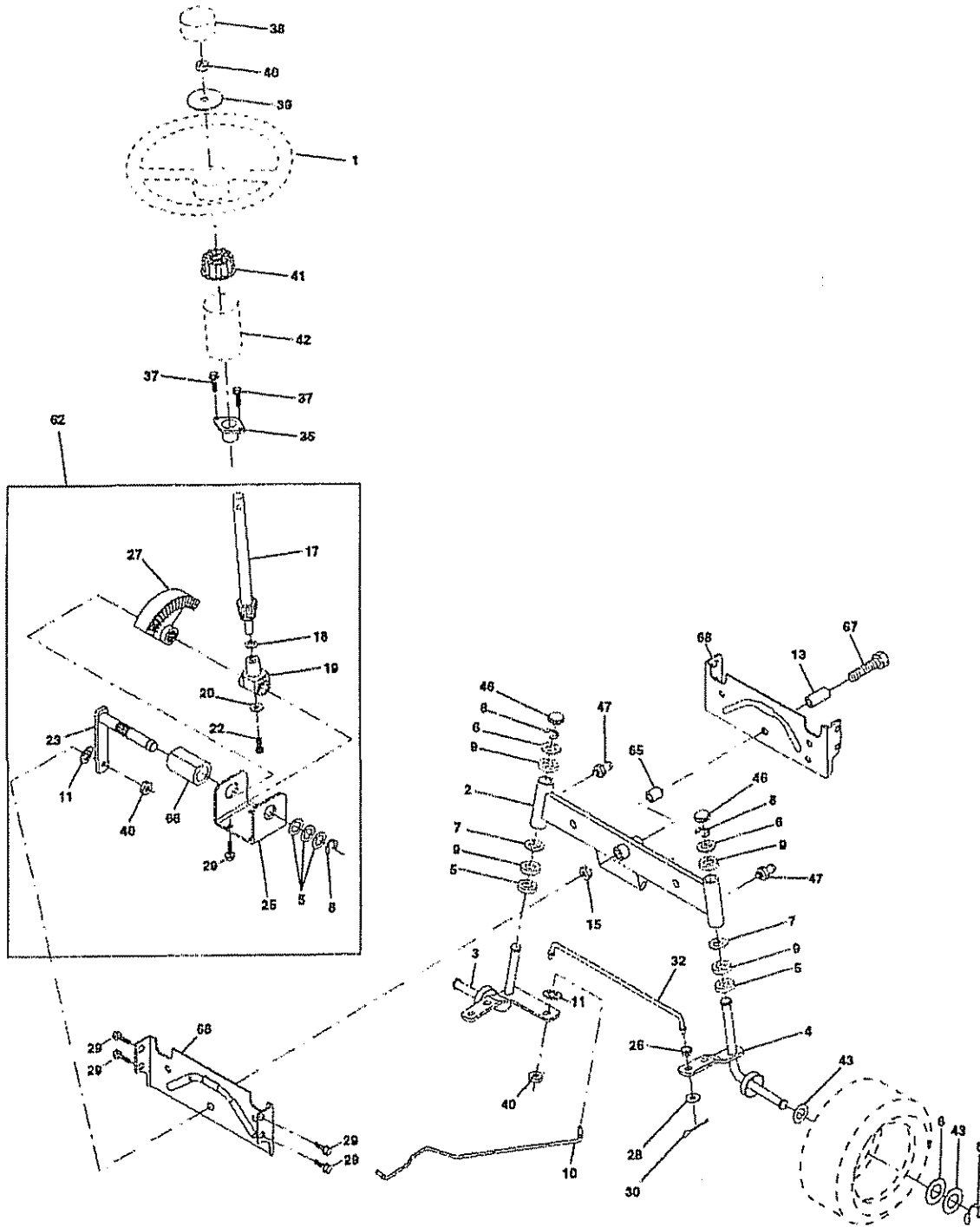



**TRACTOR - - MODEL NUMBER 917.270411**  
**STEERING ASSEMBLY**

KEY NO.	PART NO.	DESCRIPTION
1	139768	Steering Wheel
2	154427	Axle Assembly STMP Dropped STL
3	156483	Spindle Assembly, L.H.
4	157473	Spindle Assembly, R.H.
5	6266H	Bearing, Race, Thrust, Hardened
6	121748X	Washer 25/32 x 1-5/8 x 16 Gauge
7	19272016	Washer 27/32 x 1-1/4 x 16 Gauge
8	12000029	Ring, Klip
9	3366R	Bearing, Steering Column
10	156438	Draglink Extended Stamped
11	STD551137	Washer, Lock
13	154779	Bearing Axle STLT/GT
15	73901000	Nut, Lock, Flange 5/8-11 UNC
17	156545	Shaft Assembly, Steering
18	57079	Washer, Thrust .515 x .750 x .033
19	124035X	Support, Shaft
20	126684X	Washer, Shim 1/4 x 5/8 x .062
22	71200410	Screw, Hex Socket 1/4-20 x 5/8
23	127501	Pittman Shaft Assembly
25	154406	Bracket, Steering
26	126847X	Bushing, Link, Drag
27	136874	Gear, Sector
28	19131416	Washer 13/32 x 7/8 x 16 Gauge
29	17490612	Screw, Thd., Roll. 3/8-16 x 3/4
30	STD561210	Pin
32	130465	Rod, Tie
36	155099	Bushing, Steering
37	152927	Screw
38	139769	Insert, Steering Wheel
39	19133808	Washer 13/32 x 2-3/8 x 8 Gauge
40	STD541537	Gripco Nut
41	104820X	Adaptor, Steering Wheel
42	124417X	Boot, Steering Shaft
43	121749X	Washer 25/32 x 1-1/4 x 16 Gauge
46	121232X	Cap, Spindle
47	6855M	Fitting, Grease
62	156593	Kit Steering Asm Service
65	154780	Spacer Axle
66	154404	Bearing Arm Pittman
67	74781044	Bolt, Fin Hex 5/8-11 UNC x 2-3/4
68	154429	Axle, Brace

**NOTE:** All component dimensions given in U.S. inches  
1 inch = 25.4 mm

# TRACTOR -- MODEL NUMBER 917.270411

## ENGINE

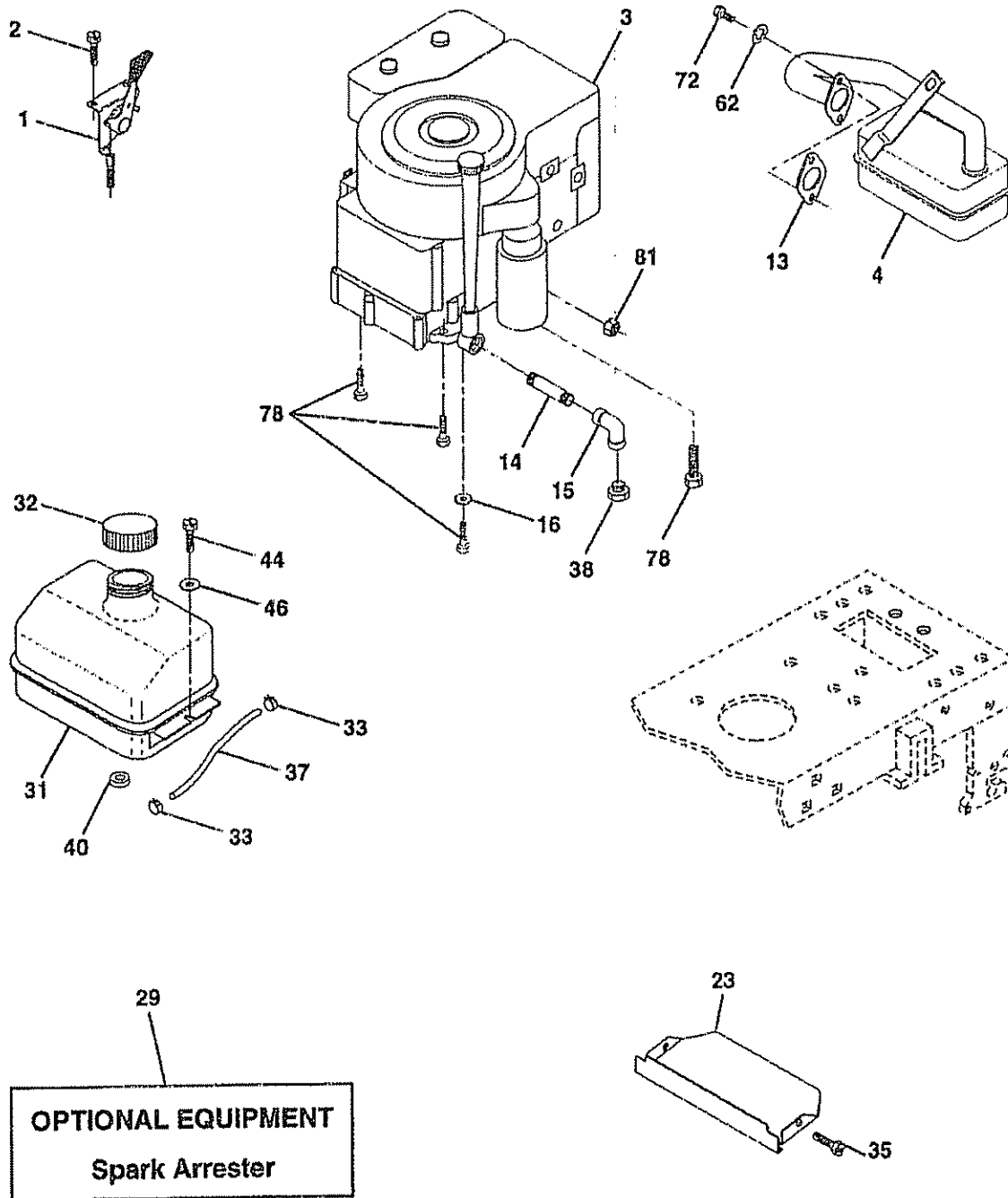

## TRACTOR - - MODEL NUMBER 917.270411

KEY NO.	PART NO.	DESCRIPTION
1	162144	Control Th/ch RH Blk Pdl 15 10
2	17720410	Screw Hex Thd Cut 1/4-20x5/8 T
3	-----	Engine B&S (See Breakdown) Model No 28R707-1140-E1
4	137348	Muffler LT B&S 12/12 5/13 HP
13	272293	Gasket Eng 1 3/13 Id Tin Plated
14	13280324	Nipple Pipe 3/8 Npt x 3"
15	13200300	Elbow Std 90 Degree 3/8-18 Npt
16	STD551237	Washer Lock Ext Tooth 3/8
23	159880	Shield Browning
29	137180	Kit Spark Arrestor (Flat Scrn)
31	109202X	Tank Fuel Front 1 25
32	158990	Cap Asm Fuel W/sym Vented
33	123487X	Clamp Hose Blk
35	17490512	Screw Thdrol 5/16-18 x 3/4 TYT
37	137040	Line Fuel 20"
38	-----	Plug Oil Drain (Order From Engine Manufacturer)
40	124028X	Bushing Snap Nyl Blk Fuel Line
44	17490412	Screw Hexwsh Thdrol 1/4-20 x 3/4
46	19091416	Washer 9/32 x 7/8 x 16 ga
62	STD551131	Washer Lock Hvy Hicl Spr 5/16
72	71070512	Screw Hex Hd Cap 5/16-18 X 3/4
78	17490620	Screw Thdrol 3/8-16x1-1/4 TYTT
81	128861	Nut Flange 1/4-20 Starter Nut

**NOTE:** All component dimensions given in U.S. inches  
1 inch = 25.4 mm

# TRACTOR -- MODEL NUMBER 917.270411

## SEAT ASSEMBLY

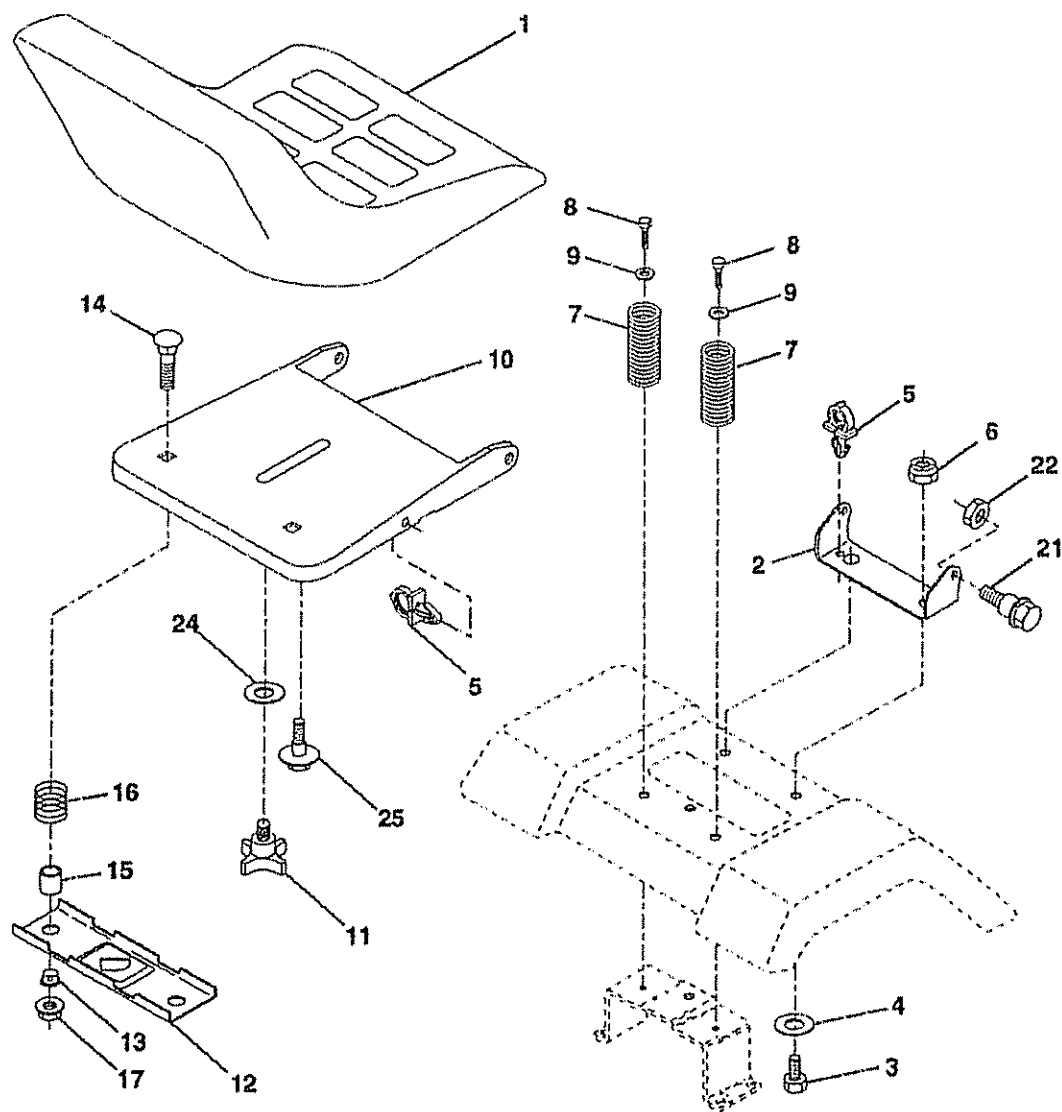

KEY NO.	PART NO.	DESCRIPTION	KEY NO.	PART NO.	DESCRIPTION
1	140122	Seat			
2	140551	Bracket Pvt St	14	72050412	Nyl 50 Id Bolt Rdhd Sht Nk 1/4-20x1-1/2
3	STD523710	Bolt Fin Hex 3/8-16unc X 1	15	134300	Spacer Split 28x 96 Yel Zinc
4	19131610	Washer Flat 13/32 X 1 X 10 Ga	16	121250X	Spring Cprsn 1 27 Blk Pnt
5	145006	Clip Push-In Hinged	17	123976X	Nut Lock 1/4 Lge Flg Gr 5 Zinc
6	STD541437	Locknut Hex W/Wsh 3/8-16	21	153236	Bolt Shld 5/16-18 Unc
7	124181X	Spring Seat Cprsn 2 250 Blk Zi	22	STD541431	Nut Lock Hex *W/ins 5/16-18
8	17490616	Screw Thdrol 3/8-16 X 1 Ty-tt	24	19171912	Washer 17/32 X 1-3/16 X 12 Ga
9	19131614	Washer 13/32 X 1 X 14 Ga	25	127018X	Bolt Shoulder 5/16-18 X 62
10	155925	Pan Seat			
11	120068	Knob Seat 1/2-13			
12	121246X	Bracket Mounting Switch			
13	121248X	Bushing Snap Blk			

NOTE: All component dimensions given in U S. Inches  
1 Inch = 25.4 mm

TRACTOR -- MODEL NUMBER 917.270411

DECALS

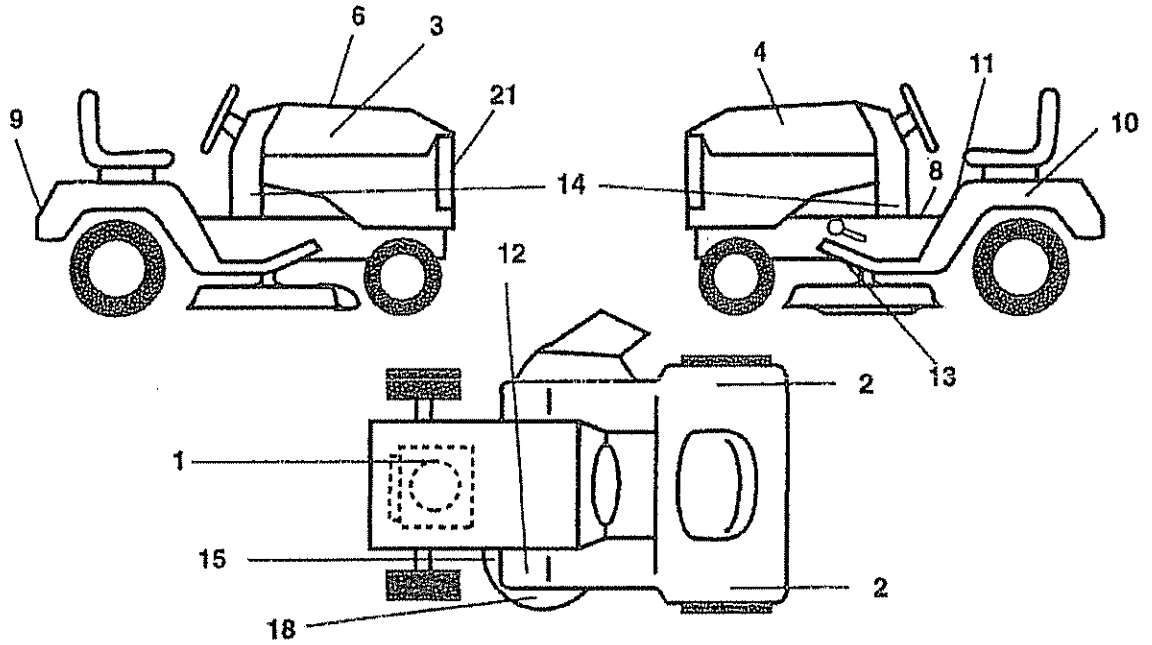

KEY NO.	PART NO.	DESCRIPTION	KEY NO.	PART NO.	DESCRIPTION
1	273297	Decal, Engine	12	4900J	Decal, Clutch/brake English
2	163209	Decal, Fender	13	146046	Decal, V-Belt Dr Sch Tractor
3	163990	Decal, Hood RH Crafts Slip LT	14	163248	Decal, Panel Dash
4	163991	Decal, Hood LH Crafts Slip LT	15	160396	Decal, V-Belt Sch
6	133644	Decal, Maint Cust Sears Domestic	18	133179	Decal, Mower Qc System
8	156867	Decal, Oper Sdl PA. Gear	21	131265	Decal, Lightbox
9	163204	Decal, Fender Craftsman White	--	157199	Pad Footrest
10	149516	Decal, Battery Dngr/Psn Eng Acme	--	138311	Decal, Handle Lft Height Adjust
11	156439	Decal, Fender Eng/spar/Dnger	--	164841	Manual Owners English
			--	164842	Manual Owners Spanish

WHEELS & TIRES

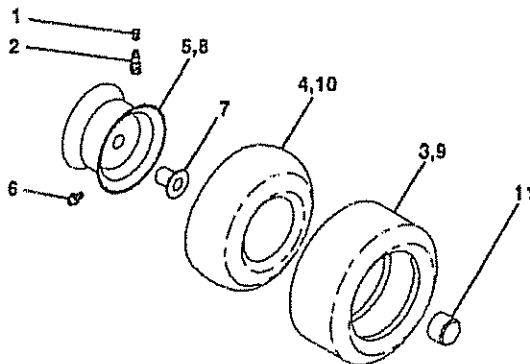

KEY NO.	PART NO.	DESCRIPTION
1	59192	Cap Valve Tire
2	65139	Stem Valve
3	106222X	Tire F Ts 15 X 6 0 - 6 Service
4	59904	Tube Front (Service Item Only)
5	106732X427	Rim Asm 6" front White Service
6	278H	Fitting Grease (Front Wheel Only)
7	9040H	Bearing Flange (Front Wheel Only)
8	106108X427	Rim Asm 8" rear White Service
9	124635X	Tire R Ts 18x8 5-8 C Service
10	7152J	Tube Rear (Service Item Only)
11	104757X	Cap Hub Axle Blk 1 50 X 1 00
--	144334	Sealant, Tire (10 oz. Tube)

NOTE: All component dimensions given in U.S. inches  
1 inch = 25.4 mm

TRACTOR -- MODEL NUMBER 917.270411

LIFT ASSEMBLY

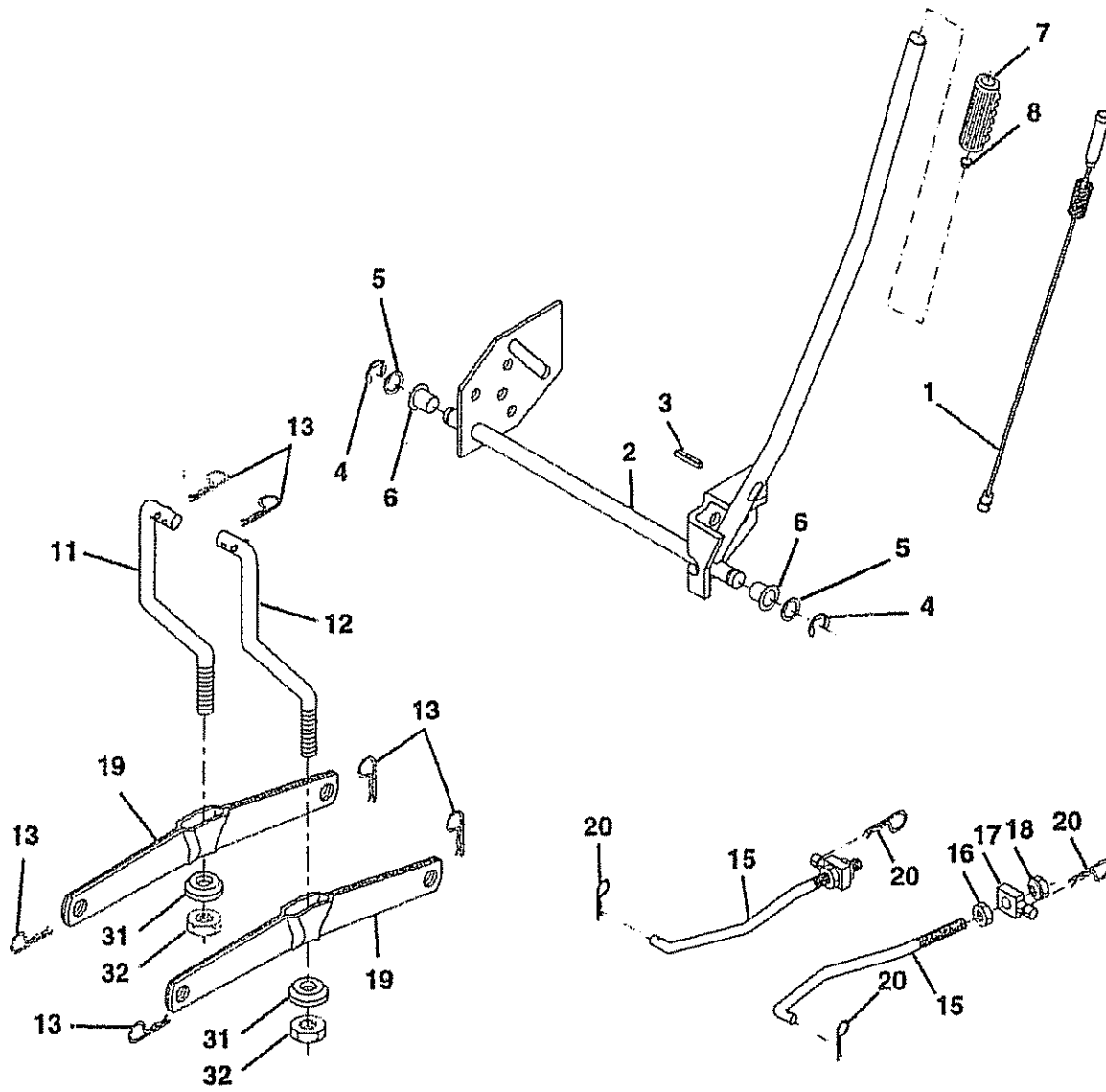

## LIFT ASSEMBLY

KEY NO.	PART NO.	DESCRIPTION
1	159460	Wire Asm Inner W/plunger
2	159474	Shaft Asm Lift
3	105767X	Pin Groove 1 500 Zinc
4	12000002	E Ring #5133-62
5	19211621	Washer Pltd 21/32 X 1 X 21ga
6	120183X	Bearing Nylon Blk 629 Id
7	125631X	Grip Handle Fluted Blk
8	122365X	Button Plunger Red
11	139865	Link Lift LH
12	139866	Link Lift RH
13	STD624008	Retainer Spring
15	127218	Link Front
16	73350800	Nut Jam Hex 1/2-13 Unc
17	130171	Trunnion Blk Zinc
18	73800800	Nut Lock W/wsh 1/2-13unc
19	139868	Arm Suspension Rear
20	STD624008	Retainer Spring Zinc
31	140302	Bearing Pvt Lift Spherical
32	73540600	Nut Crownlock 3/8-24

**NOTE:** All component dimensions given in U.S. inches  
1 inch = 25.4 mm

TRACTOR -- MODEL NUMBER 917.270411

MOWER DECK

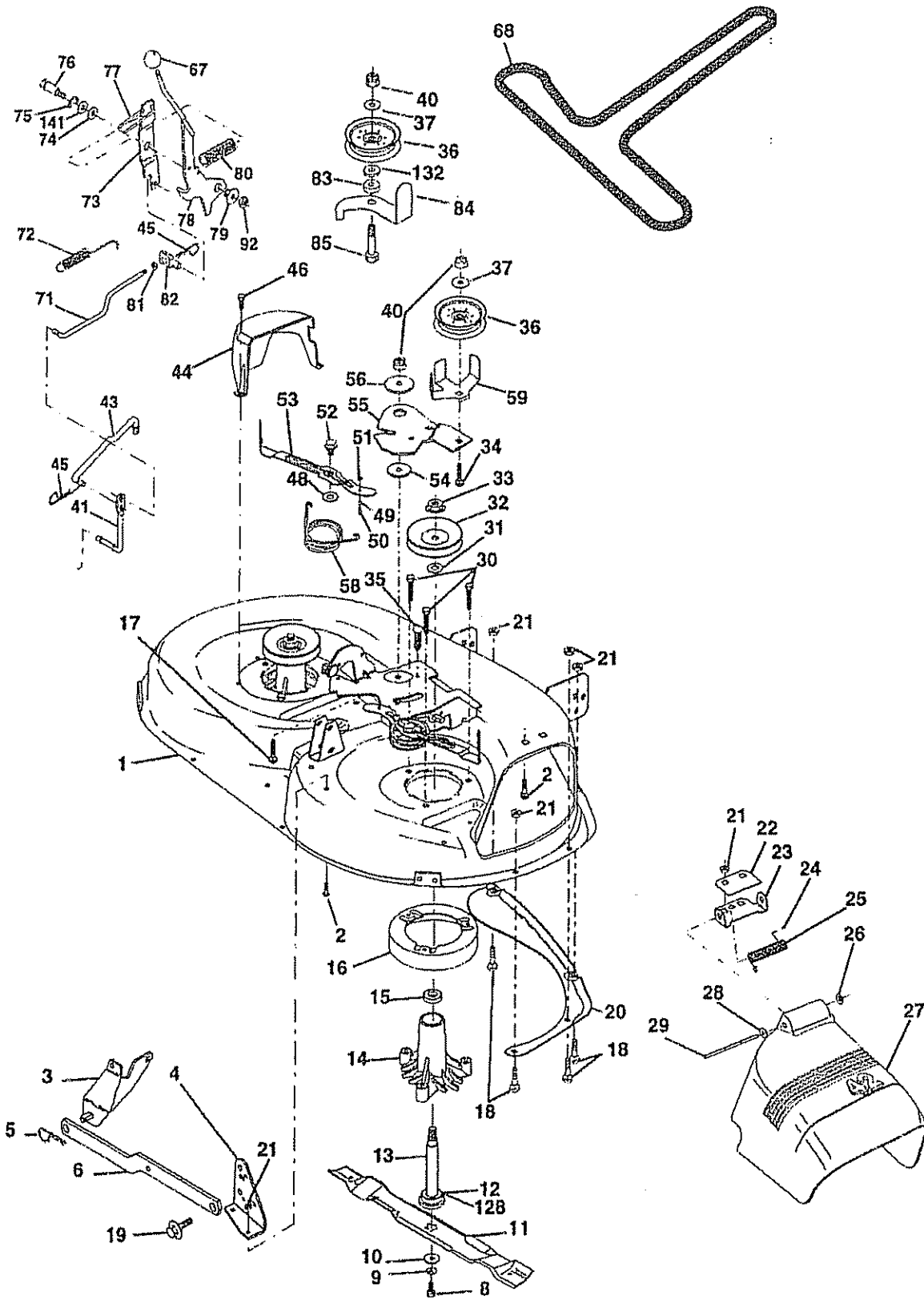



# TRACTOR - - MODEL NUMBER 917.270411

## MOWER DECK

KEY NO.	PART NO.	DESCRIPTION	KEY NO.	PART NO.	DESCRIPTION
1	144393	Mower Housing	45	STD624003	Retainer
2	STD533107	Bolt	46	137729	Screw, Thd. Roll 1/4-20 x 5/8
3	138017	Bracket Assembly, Sway Bar, Front	48	133944	Washer, Hardened
4	138440	Bracket Assembly, Sway Bar	49	155066	Roller Assembly, Cam Follower
5	STD624008	Retainer Spring	50	131340	Bolt, Shoulder #10-24 Grade 5
6	130832	Arm, Suspension, Rear	51	STD541410	Locknut
8	850857	Bolt, Hex 3/8-24 x 1.25 Grade 8	52	139888	Bolt, Shoulder 5/16-18 UNC
9	STD551137	Washer, Lock	53	131845	Arm Assembly, Pad, Brake
10	140296	Washer, Hardened	54	133943	Washer, Hardened
11	134149	Blade, Mulching	55	155046	Arm, Idler
12	129895	Bearing, Ball	56	122052X	Spacer, Retainer
13	137645	Shaft Assembly, Mandrel, Vented (Includes Key Number 6)	58	140086	Spring, Torsion Brakes 42"
14	128774	Housing, Mandrel, Vented	59	141043	Guard, Tuv Idler (94)
15	110485X	Bearing, Ball, Mandrel	67	162113	Knob, Custom Oval
16	140329	Stripper, Vented Mower Deck	68	144200	V-Belt
17	72110610	Bolt, Carriage 3/8-16 x 2-1/4	71	142427	Rod, Clutch, Primary, with Nibs
18	72140505	Bolt, Carriage 5/16-18 x 5/8	72	131870	Spring, Return
19	132827	Bolt, Shoulder	73	127847	Arm, Clutch, Secondary
20	159770	Baffle, Vortex	74	121748X	Washer 25/32 x 1-5/8 x 16 Gauge
21	STD541431	Nut, Crownlock 5/16-18 UNC	76	128903	Bolt, Shoulder 3/8-16 UNC x 1.44
22	134753	Stiffener Bracket	77	127845	Keeper, Spring
23	131267	Bracket, Deflector	78	160571	Arm, Clutch, Primary
24	105304X	Cap, Sleeve	79	127498	Bushing, Large, Brass
25	123713X	Spring, Torsion, Deflector	80	153701	Spring, Mower Clutch
26	110452X	Nut, Push	81	73350600	Nut, Hex Jam 3/8-16 UNC
27	130968	Shield, Deflector	82	142028	Trunnion Adj. 94
28	19111016	Washer 11/32 x 5/8 x 16 Gauge	83	120958X	Washer, Sintered
29	131491	Rod, Hinge	84	156084	Keeper, Belt Idler
30	157722	Screw Thdrol Hex Head Zinc Mwr	85	72140620	Bolt Rdhd Sq 3/8-16unc x 2-1/2
31	129963	Washer, Spacer	92	STD541437	Locknut, Hex W/Wsh 3/8-16 UNC
32	153535	Pulley, Mandrel	128	153390	Washer Felt
33	137266	Nut, Toplock, Flanged	132	19132203	Spacer, Washer 13/32 I.D. x 1-3/8 O.D. x 1/4
34	STD533717	Bolt	141	6266H	Washer Thrust .75 x 1.230
35	133835	Fasiner, Christmas Tree	--	130794	Mandrel Assembly (Includes Key Numbers 8-10, 12-15, 31 and 32)
36	131494	Pulley, Idler, Flat	--	145411	Mower Deck, Complete
37	STD551037	Washer 13/32 x 13/16 x 16 Ga.	Available Mulcher Plate Kit not included with tractor:		
40	STD541437	Nut, Crownlock 3/8-16 UNC	--	141112	Mulcher Close-out Plate Kit
41	133551	Rod, Pivot, with Nibs			
43	140083	Rod, Clutch, Secondary, with Nibs			
44	140088	Guard, Mandrel, L.H.			

**NOTE:** All component dimensions given in U.S. inches  
1 inch = 25.4 mm

TRACTOR - - MODEL NUMBER 917.270411

DANA TRANSAXLE - - MODEL NUMBER D4360-128

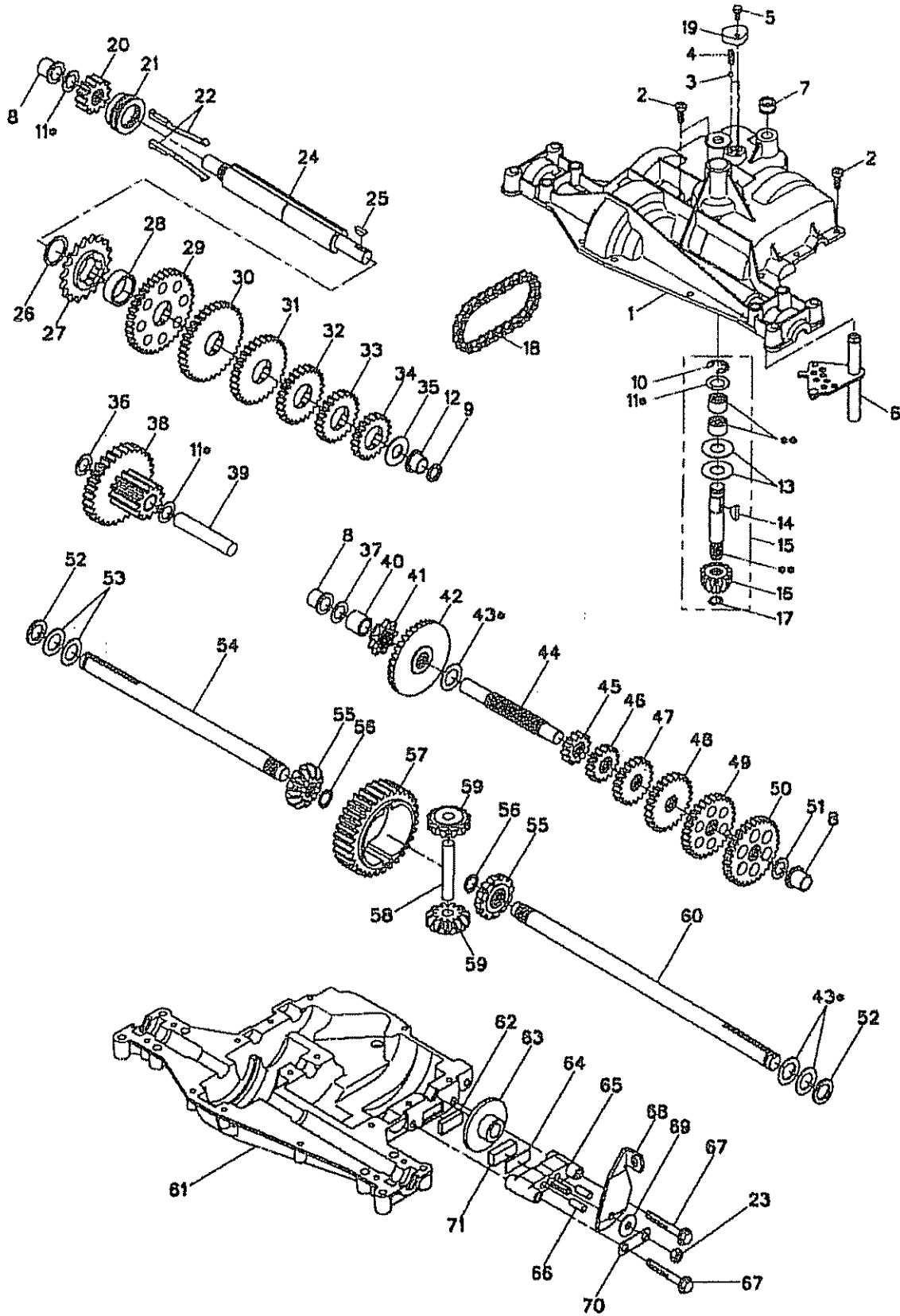

**TRACTOR -- MODEL NUMBER 917.270411**  
**DANA TRANSAXLE -- MODEL NUMBER D4360-128**

KEY NO.	PART NO.	DESCRIPTION	KEY NO.	PART NO.	DESCRIPTION
1	160955	Housing, Upper	38	160944	Assy, Gear, Comb., 12T & 30T
2	2274J	Screw, Tapping, 1/4-20 X .734	39	124639X	Shaft, Idler
3	134400	Ball, Detent	40	120472X	Spacer, .633 X .87 X .755
4	105904X	Spring, Detent	41	105928X	Sprocket, 9T
5	160940	Screw, Tapping, No. 10-24 X .482	42	161565	Gear, Bevel, 36T
6	138235	Assy, Kit, Shifter	43	134394	Assy, Kit, Shim, .750 Shaft
7	108727X	V-Ring	44	120473X	Shaft, Drive
8	148266	Bearing, Flange	45	142678	Gear, Spur, 12T
9	148269	Seal, Oil	46	143697	Gear, Spur, 15T
10	2225J	Ring, Retaining	47	124641X	Gear, Spur, 20T
11	134793	Assy, Kit, Shim, .625 Shaft	48	106589X	Gear, Spur, 25T
12	148268	Bearing, Flange	49	120408X	Gear, Spur, 28T
13	120415X	Washer, Plain, .632 X 1.38 X .046	50	105937X	Gear, Spur, 31T
14	142674	Key, Woodruff, No. 9	51	2226J	Washer, Plain, .632 X 1.00 X .060
15	161563	Assy, Kit, Input Shaft	52	134401	Washer, Neoprene
16	161564	Pinion, Bevel, 12T	53	2264J	Washer, Plain, .758 X 1.25 X .031
17	105909X	Ring, Retaining	54	160946	Axle, LH
18	105910X	Chain, 24 Pitches	55	160947	Gear, Miter, 12T, Splined
19	160942	Cover, Detent	56	160948	Ring, Retaining
20	160943	Gear, Spur, 12T	57	110071X	Gear, Spur, 32T
21	148267	Collar, Clutch	58	120952X	Shaft, Cross
22	138236	Assy, Kit, Clutch Keys	59	160949	Gear, Miter, 12T, Idler
23	73810500	Nut, Lock, 5/16-24	60	160950	Axle, RH
24	142676	Shaft, Intermediate	61	160951	Housing, Lower
25	2244J	Key, Woodruff, No. 61	62	120961X	Puck, Friction
26	105916X	Ring, Retaining	63	7294J	Disc, Brake
27	120470X	Sprocket, 18T	64	108989X	Spacer, Brake Puck
28	110070X	Spacer, 1.131 X 1.45 X .494	65	160952	Jaw, Brake
29	142677	Gear, Spur, 37T	66	120954X	Pin, Dowel
30	142681	Gear, Spur, 35T	67	160953	Screw, Tapping, 5/16-18 X 2.35
31	124644X	Gear, Spur, 30T	68	138244	Lever, Actuating
32	108980X	Gear, Spur, 25T	69	108996X	Washer, Plain, .321 X 1.00 X .055
33	120406X	Gear, Spur, 22T	70	160954	Bracket, Anti-Rotation
34	134796	Gear, Spur, 19T	71	120951X	Puck, Friction
35	105925X	Washer, Plain, .640 X 1.37 X .061	72	120416X	Grease
36	2228J	Washer, Plain, .632 X 1.00 X .046			
37	2231J	Washer, Plain, .632 X 1.00 X .031			

**NOTE:** All component dimensions given in U.S. inches  
1 inch = 25.4 mm

TRACTOR - - MODEL NUMBER 917.270411

BRIGGS & STRATTON ENGINE-MODEL NUMBER 28R707, TYPE NUMBER 1140-E1

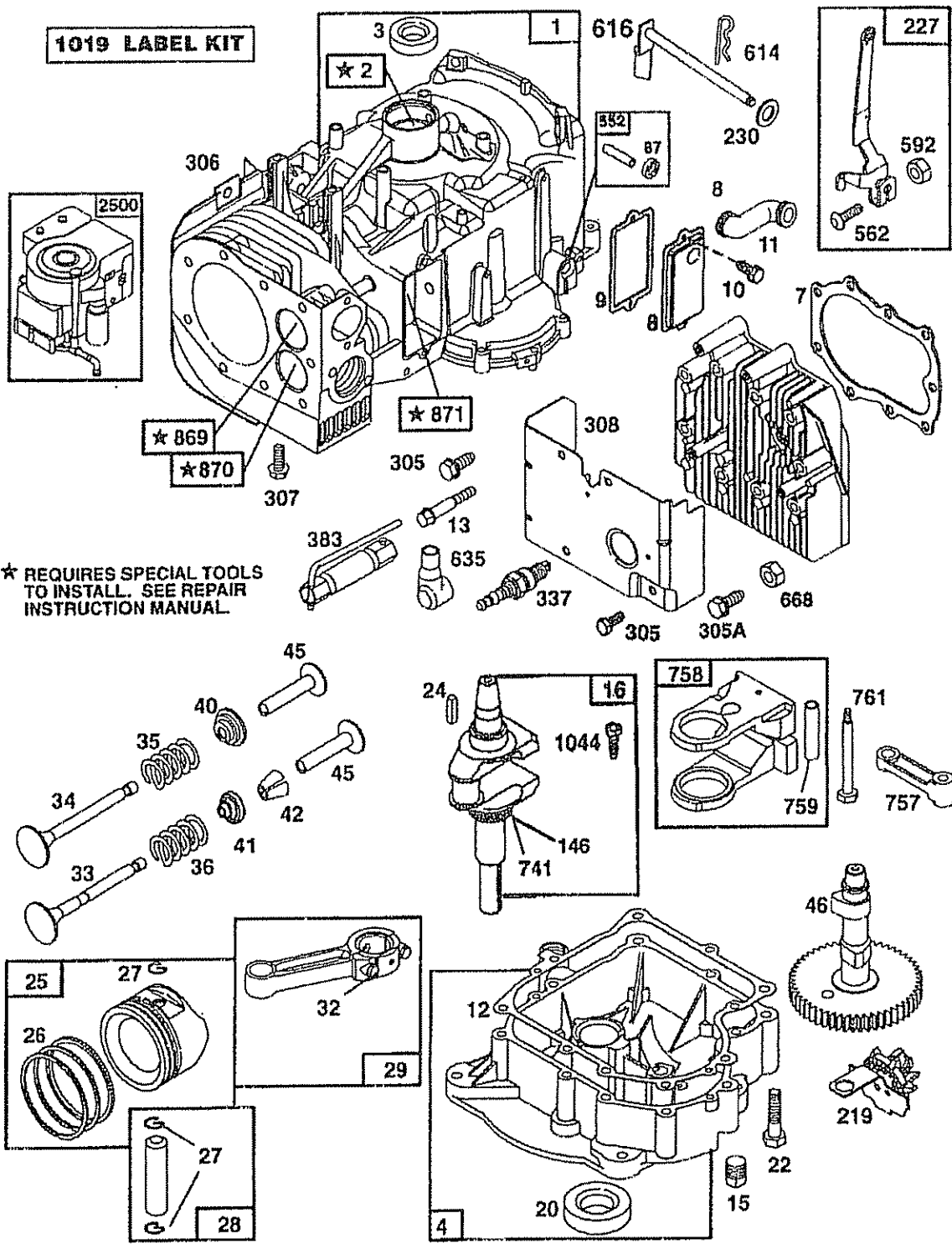

★ REQUIRES SPECIAL TOOLS TO INSTALL. SEE REPAIR INSTRUCTION MANUAL.

BRIGGS & STRATTON ENGINE-MODEL NUMBER 28R707, TYPE NUMBER 1140-E1

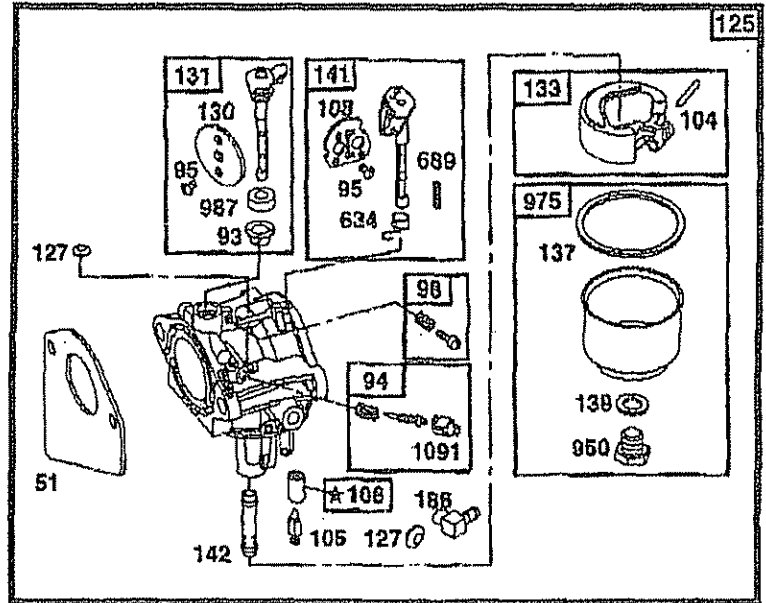
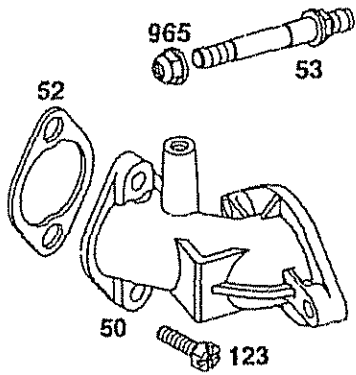

★ REQUIRES SPECIAL TOOLS TO INSTALL. SEE REPAIR INSTRUCTION MANUAL.

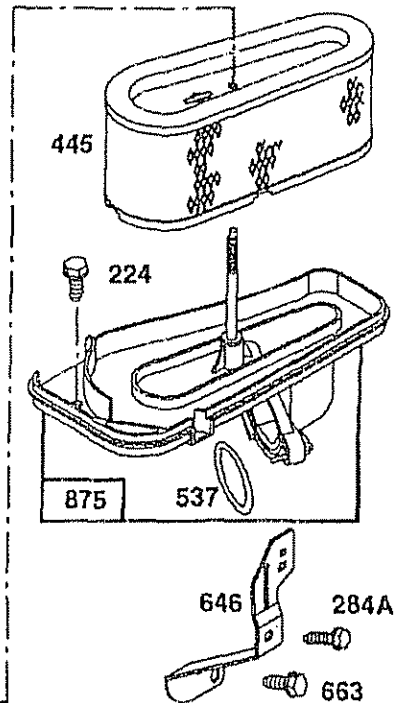
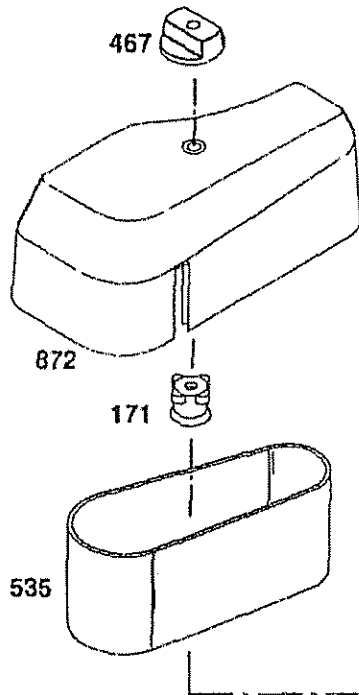
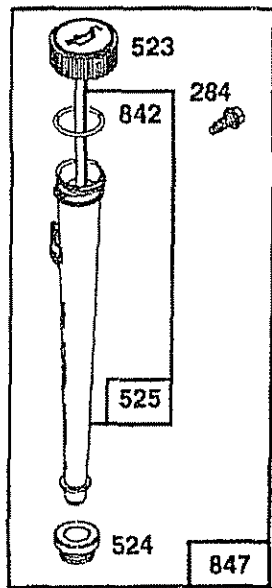

TRACTOR - - MODEL NUMBER 917.270411

BRIGGS & STRATTON ENGINE-MODEL NUMBER 28R707, TYPE NUMBER 1140-E1

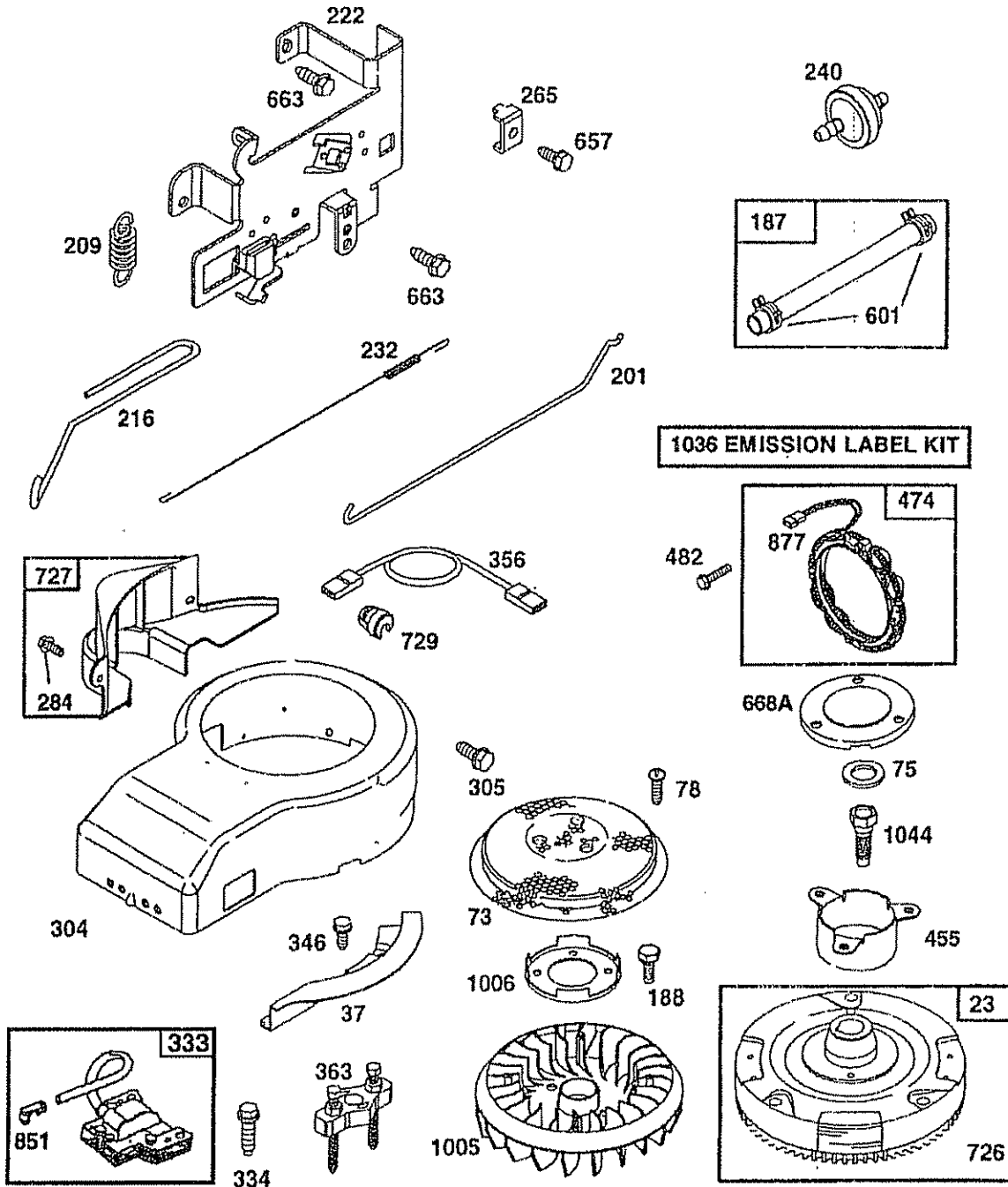

**TRACTOR - - MODEL NUMBER 917.270411**  
**BRIGGS & STRATTON ENGINE-MODEL NUMBER 28R707, TYPE NUMBER 1140-E1**

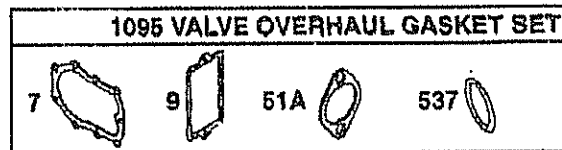
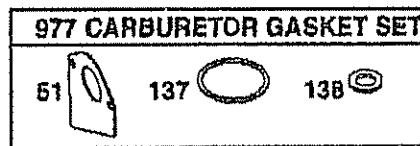
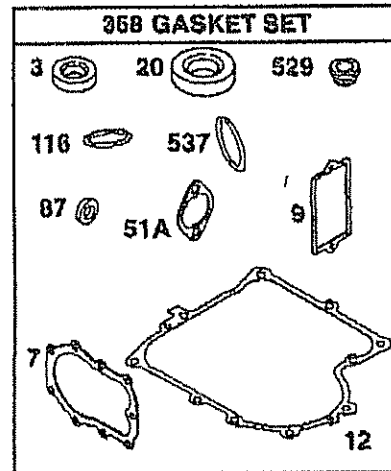
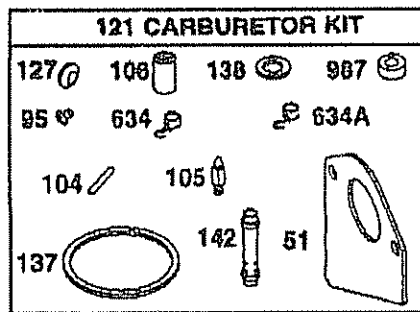
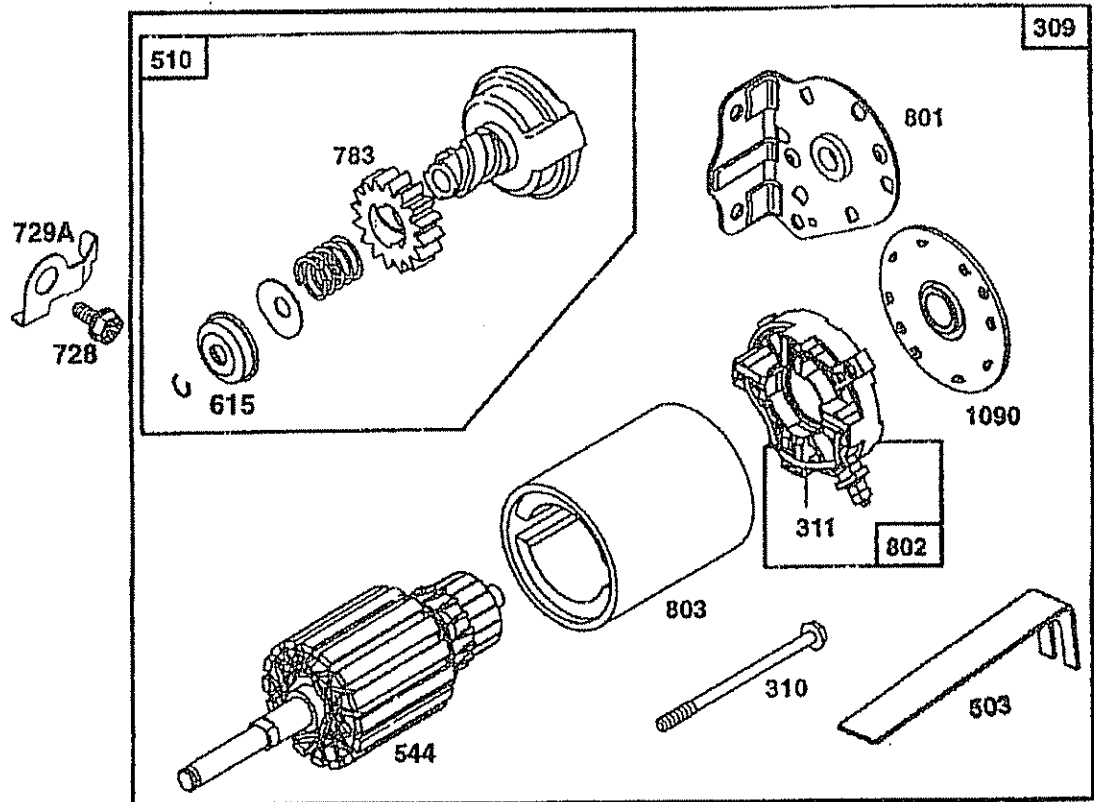

**BRIGGS & STRATTON ENGINE-MODEL NUMBER 28R707, TYPE NUMBER 1140-E1**

KEY NO.	PART NO.	DESCRIPTION	KEY NO.	PART NO.	DESCRIPTION
1	496413	Cylinder Assembly	52	272554	ø* Gasket, Carburetor
2	399265	Bearing, Cylinder	53	94637	Stud, Carburetor Mounting
3	391086	* Seal, Oil	73	224948	Screen, Rotating
4	494238	Base, Engine	75	225136	Washer, Spring
5	494240	Head, Cylinder	78	94626	Screw, Phillips
7	271866	ø* Gasket, Cylinder Head	87	491323	* Seal, Governor
8	495735	Breather Assembly (Includes Mounting Gasket)	93	281346	Bushing, Throttle Shaft
9	27803	ø* Gasket, Valve Cover	94	498030	Valve, Needle
10	94621	Screw, Sems	95	94098	** Screw, Throttle
11	280100	Tube, Breather	98	495800	Screw, Idle Adjust
12	271916	* Gasket, Crankcase Cover, 1/64"	104	231789	** Pin, Float Hinge
	271997	* Gasket, Crankcase Cover, .005"	105	231855	** Valve, Inlet Needle
	271996	* Gasket, Crankcase Cover, .009"	106	231854	** Seat, Inlet
13	94622	Screw, Cylinder Head	108	224540	Valve, Choke
15	94239	Plug, Oil Drain	121	499220	Carburetor Kit
16	498971	Crankshaft	123	94913	Screw, Elbow Mounting
20	291675	* Seal, Oil	125	498027	Carburetor
22	94624	Screw, Sems, Base Mounting	127	- - -	** Plug, Welch (Sold in Kit Only)
23	492326	Flywheel	130	224539	Valve, Throttle
24	222698	Key, Flywheel	131	494379	Shaft, Throttle
25	394661	Piston Assembly, Standard Size	133	494381	Float, Carburetor
	394662	Piston Assembly, .010" Oversize	137	281165	*** Gasket, Float Bowl
	394663	Piston Assembly, .020" Oversize	138	281164	*** Washer, Float Bowl
	394664	Piston Assembly, .030" Oversize	141	495097	Shaft, Choke
26	391780	Ring Set, Standard Size	142	497736	** Nozzle, Carburetor
	392331	Ring Set, Standard Size, Chrome		497737	Nozzle, Carburetor (High Altitude)
	391781	Ring Set, .010" Oversize	146	94196	Key, Timing
	391782	Ring Set, .020" Oversize	171	281051	Nut, Air Cleaner
	391783	Ring Set, .030" Oversize	186	493496	Elbow, Fuel Pipe
27	260924	Lock, Piston Pin	187	298049	Line, Fuel (Cut to Suit)
28	299691	Pin, Piston, Standard Size	188	94627	Screw, Sems
	391286	Pin, Piston, .005" Oversize	201	262767	Link, Governor
29	490348	Rod, Connecting	209	260871	Spring, Governor
	490469	Rod, Connecting, .020" Undersize	216	262766	Link, Choke
32	94671	Screw, Connecting Rod	219	490815	Gear, Governor
33	262246	Valve, Exhaust	222	495611	Plate, Governor Control
34	262247	Valve, Intake	224	94729	Screw, Hex Head
35	65906	Intake Exhaust Valve	227	493935	Lever Assembly, Governor
36	26828	Spring, Valve	230	94927	Washer, Governor Crank
37	224502	Guard, Flywheel	232	262785	Spring, Governor Link
40	221596	Retainer, Intake Valve	240	394358	Filter, Fuel
41	292260	Rotocoll, Exhaust Valve	265	221535	Clamp, Casing
42	494553	Retainer, Rotocoll			
45	262248	Tappet, Valve			* Included in Gasket Set (494241)
46	212897	Gear, Cam			** Included in Carburetor Kit (499220)
50	213819	Carburetor, Elbow			*** Included in both Carburetor Kit (499220), and Carburetor Gasket Set (494385)
51	272465	*** Gasket, Carburetor			ø Included in Valve Overhaul Gasket Set

**NOTE:** All component dimensions given in U.S. inches  
1 inch = 25.4 mm



**BRIGGS & STRATTON ENGINE-MODEL NUMBER 28R707, TYPE NUMBER 1140-E1**

KEY NO.	PART NO.	DESCRIPTION	KEY NO.	PART NO.	DESCRIPTION
284	94903	Screw, Shoulder	726	392134	Gear, Ring
284A	94704	Screw, Hex Head	727	490324	Cover, Starter
304	496280	Housing, Blower	728	94951	Screw, Torx®
305	94786	Screw, Hex Head	729	281159	Clip, Lead Wire
305A	94881	Screw, Hex	729A	225170	Retainer, Wire
306	224545	Shield, Cylinder	741	262932	Gear, Timing
307	94930	Screw, Sems	757	213998	Link, Counterweight
308	491490	Cover, Cylinder Head	758	399891	Counterweight Assembly
309	497595	Motor, Starter	759	298909	Pin, Counterweight
310	94003	Thru Bolt	761	94593	Screw, Counterweight
311	497608	Brush Assembly	763	280104	Gear
333	492341	Armature, Magneto	801	394856	Cap, Drive
334	094731	Screw, Sems	802	497605	Cap, End
337	802592	Plug, Spark	803	497604	Housing, Starter
346	94896	Screw, Hex Head	842	270920	* Seal, Cap
356	494328	Wire Assembly	847	496415	Tube Assembly, Oil
358	494241	Gasket Set	851	493880	Terminal, Ignition Cable
363	19203	Puller, Flywheel	869	261463	Seat, Intake Valve
383	89838	Wrench, Spark Plug	870	262924	Seat, Exhaust Valve
445	496894	Cartridge, Air Cleaner	871	281961	Guide, Exhaust Valve
455	221561	Cap, Flywheel		231218	Guide, Intake Valve, Brass
467	493903	Knob, Air Cleaner	872	281361	Cover, Air Cleaner
474	393474	Stator, Alternator	875	494237	Body, Air Cleaner
482	93621	Screw, Sems	877	393456	Diode Assembly
503	806000	Strap, Starter	950	94642	Screw, Fuel Bowl
510	497606	Starter Drive Group	965	94010	Nut, Hex
523	495230	Dipstick, Oil	975	495933	Bowl, Float
524	281370	* Seal, Oil	977	494385	Carburetor Gasket Set
525	496113	Tube, Oil Filler	987	281166	** Seal, Throttle Shaft
535	272403	Element, Filter	1005	281400	Fan, Flywheel
537	281106	∅* O-Ring, Air Cleaner	1006	224413	Retainer, Fan
544	497603	Armature, Starter	1019	491252	Label Kit
552	491986	Bushing, Governor Crank	1036	499362	Label, Kit, Emission
562	94907	Bolt, Governor Lever	1044	94673	Screw, Hex Head
592	231978	Nut, Hex	1045	231828	Extension, Crankshaft
601	93053	Clamp, Fuel Pipe	1090	497607	Retainer, Brush
614	93306	Pin, Cotter	1091	281364	Cap, Limiter
615	263080	Retainer	1095	498539	Gasket Set, Valve Overhaul
616	495157	Crank, Governor	2500	28R707-1140	Replacement Engine
634	494453	* Seal, Spring Assembly	—	496050	Replacement Shortblock
635	66538	Elbow, Spark Plug			
646	224546	Brace, Air Cleaner			RPM Settings: Low Speed: 1900-2100 High Speed: 3000-3200
657	94906	Screw, Sems			
663	94929	Screw, Hex Head			
668	231109	Spacer			* Included in Gasket Set (494241)
668A	280848	Spacer			** Included in Carburetor Kit (499220)
689	262820	Spring, Friction			*** Included in both Carburetor Kit (499220), and Carburetor Gasket Set (494385)

**NOTE:** All component dimensions given in U.S. inches  
1 inch = 25.4 mm



## SUGGESTED GUIDE FOR SIGHTING SLOPES FOR SAFE OPERATION

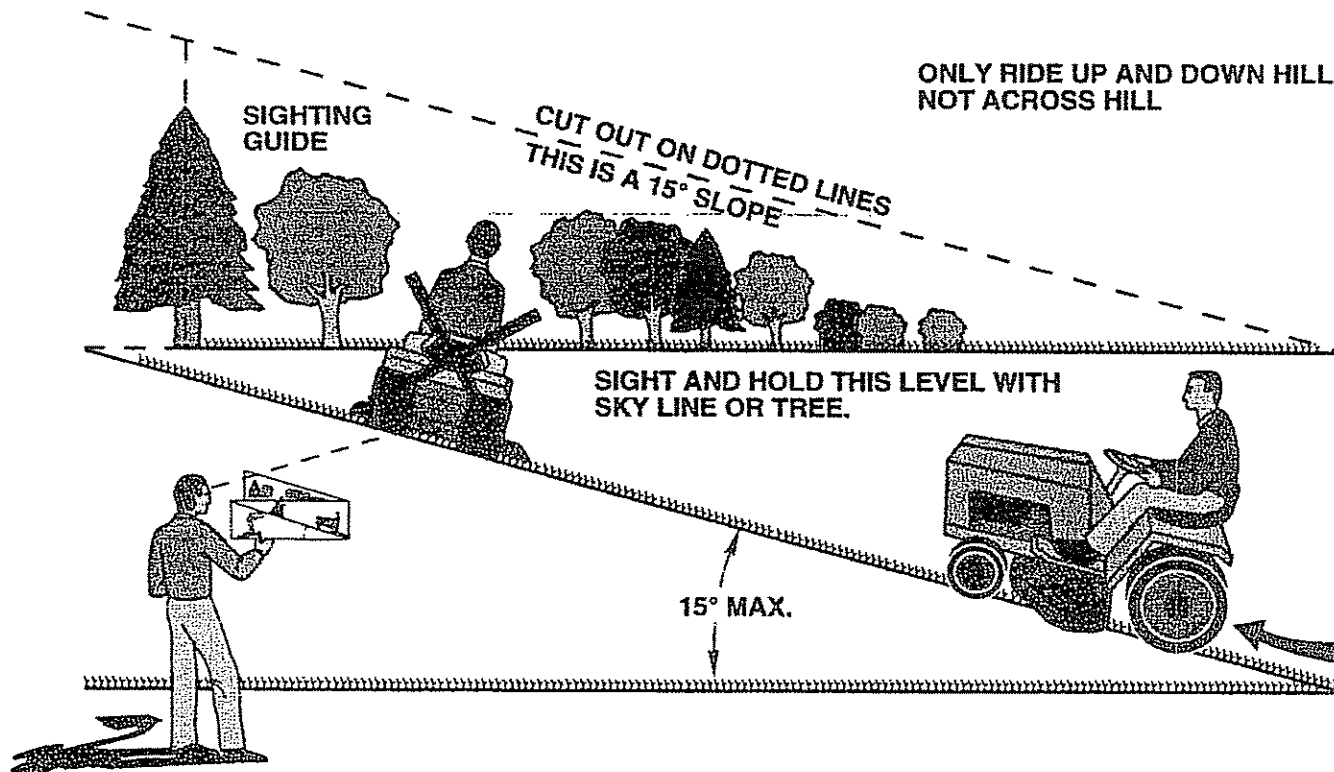

Operate your Tractor up and down the face of slopes (not greater than 15°), never across the face. Make turns gradually to prevent tipping or loss of control. Exercise extreme caution when changing direction on slopes.

For the repair or replacement parts you need  
delivered directly to your home  
Call 7 am - 7 pm, 7 days a week

**1-800-366-PART**

(1-800-366-7278)

Para ordenar piezas con entrega a  
domicilio – 1-800-659-7084

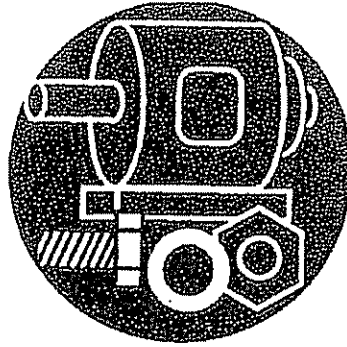

For in-house major brand repair service  
Call 24 hours a day, 7 days a week

**1-800-4-REPAIR**

(1-800-473-7274)

Para pedir servicio de reparación a  
domicilio – 1-800-676-5811



For the location of a Sears Parts and  
Repair Center in your area

Call 24 hours a day, 7 days a week

**1-800-488-1222**



For information on purchasing a Sears  
Maintenance Agreement or to inquire  
about an existing Agreement

Call 9 am – 5 pm, Monday–Saturday

**1-800-827-6655**

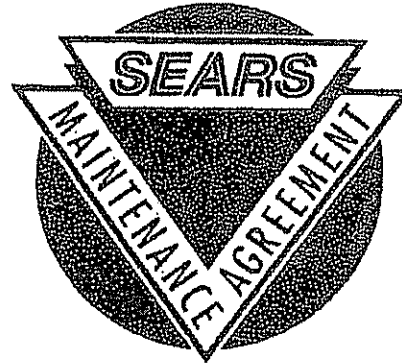

When requesting service or ordering  
parts, always provide the following  
information:

- Product Type
- Part Number
- Model Number
- Part Description

**SEARS**  
**REPAIR SERVICES**

*America's Repair Specialists*