

**SEARS**  
**OWNERS**  
**MANUAL**

**MODEL NO.**  
**917.254550**



**CRAFTSMAN**

**LT 12 HP ELECTRIC START**  
**6 SPEED - 38" MOWER**  
**LAWN TRACTOR**

**Caution:**  
**Read and Follow**  
**All Safety Rules**  
**And Instructions**  
**Before Operating**  
**This Equipment**

- **Assembly**
- **Operation**
- **Maintenance**
- **Repair and Adjustment**
- **Repair Parts**

*Sears, Roebuck and Co., Chicago, IL 60684 U.S.A.*

121030X 12.1.87  
Printed in U.S.A.

# SAFETY RULES

1. Know the controls and how to stop quickly. READ THIS OPERATOR'S MANUAL and instructions furnished with attachments.
2. Do not allow children to operate the machine. Do not allow adults to operate it without proper instruction.
3. Do not carry passengers. Do not mow when children and others are around.
4. Always wear substantial footwear. Do not wear loose fitting clothing that could get caught in moving parts.
5. Keep your eyes and mind on your tractor, mower and the area being cut. Do not let other interests distract you.
6. Do not attempt to operate your tractor or mower when not in the drivers seat.
7. Always get on or off your tractor from the operator's left hand side.
8. Clear the work area of objects (wire, rocks, etc.) which might be picked up and thrown.
9. Disengage all attachment clutches before attempting to start the engine.
10. Disengage power to attachments and stop the engine before leaving the operator's position.
11. Disengage power to mower, stop the engine and disconnect spark plug wire(s) from spark plug(s) before cleaning, making an adjustment or repair. Be careful to avoid touching hot muffler or engine components.
12. Disengage power to attachments when transporting or not in use.
13. Take all possible precautions when leaving the vehicle unattended. Disengage the power-take-off, lower the attachments, shift into neutral, set the parking brake, stop the engine and remove the key.
14. Do not stop or start suddenly when going, uphill or downhill. Mow up and down the face of slopes (not greater than 15°); never across the face. Refer to page 47.
15. Reduce speed on slopes and make turns gradually to prevent tipping or loss of control. Exercise extreme caution when changing direction on slopes.
16. While going up or down slopes, place Gear Shift Control Lever in 1st gear position to negotiate the slope without stopping.
17. Never mow in wet or slippery grass, when traction is unsure or at a speed which could cause a skid.
18. Stay alert for holes in the terrain and other hidden hazards. Keep away from drop-offs.
19. Do not drive too close to creeks, ditches and public highways.
20. Exercise special care when mowing around fixed objects in order to prevent the blades from striking them. Never deliberately run tractor or mower into or over any foreign objects.
21. Never shift gears until tractor comes to a stop.
22. Never place hands or feet under the mower, in discharge chute or near any moving parts while tractor or mower are running. Always keep clear of discharge chute.
23. Use care when pulling loads or using heavy equipment.
  - a. Use only approved drawbar hitch points.
  - b. Limit loads to those you can safely control.
  - c. Do not turn sharply. Use care when backing.
  - d. Use counterweight or wheel weights when suggested in the owner's manual.
24. Watch out for traffic when crossing or near roadways.
25. When using any attachments, never direct discharge of material toward bystanders nor allow anyone near the vehicle while in operation.
26. Handle gasoline with care - it is highly flammable.
  - a. Use approved gasoline containers.
  - b. Never remove the fuel cap of the fuel tank or add gasoline to a running or hot engine or an engine that has not been allowed to cool for several minutes after running. Never fill tank indoors, always clean up spilled gasoline.
  - c. Open doors if the engine is run in the garage - exhaust fumes are dangerous. Do not run the engine indoors.
27. Keep the vehicle and attachments in good operating condition, and keep safety devices in place and working.
28. Keep all nuts, bolts and screws tight to be sure the equipment is in safe working condition.
29. Never store the equipment with gasoline in the tank inside a building where fumes may reach an open flame or spark. Allow the engine to cool before storing in any enclosure.
30. To reduce fire hazard, keep the engine free of grass, leaves or excessive grease. Do not clean product while engine is running.
31. Except for adjustments; DO NOT operate Engine if air cleaner or cover directly over carburetor air intake is removed. Removal of such part could create a fire hazard.
32. Do not operate without a muffler or tamper with exhaust system. Damaged mufflers or spark arresters could create a fire hazard. Inspect periodically and replace if necessary.
33. The vehicle and attachments should be stopped and inspected for damage after striking a foreign object and the damage should be repaired before restarting and operating the equipment.
34. Do not change the engine governor settings or overspeed the engine; severe damage or injury may result.
35. When using the vehicle with mower, proceed as follows:
  - a. Mow only in daylight or in good artificial light.
  - b. Shut the engine off when unclogging chute.
  - c. Check the blade mounting bolts for proper tightness at frequent intervals.
36. Do not operate the mower without the deflector shield in place.
37. Disengage power to mower before backing up. Do not mow in reverse unless absolutely necessary and then only after careful observation of the entire area behind the mower.
38. Under normal usage the grass catcher bag material is subject to deterioration and wear. It should be checked frequently for bag replacement. Replacement bags should be checked to ensure compliance with the original manufacturer's recommendations or specifications.



LOOK FOR THIS SYMBOL TO POINT OUT IMPORTANT SAFETY PRECAUTIONS. IT MEANS--ATTENTION! BECOME ALERT! YOUR SAFETY IS INVOLVED.

CAUTION: LOOK FOR THIS WORD TO POINT OUT IMPORTANT EQUIPMENT PRECAUTIONS.



THIS UNIT IS EQUIPPED WITH AN INTERNAL COMBUSTION ENGINE AND SHOULD NOT BE USED ON OR NEAR ANY UNIMPROVED FOREST COVERED, BRUSH COVERED, OR GRASS COVERED LAND UNLESS THE ENGINE'S EXHAUST SYSTEM IS EQUIPPED WITH A SPARK ARRESTER MEETING APPLICABLE LOCAL OR STATE LAWS (IF ANY). IF A SPARK ARRESTER IS USED, IT SHOULD BE MAINTAINED IN EFFECTIVE WORKING ORDER BY THE OPERATOR.

*In the State of California the above is required by law (Section 4442 of the California Public Resources Code). Other states may have similar laws. Federal laws apply on federal lands. Refer to the Repair Parts Section.*

**CONGRATULATIONS** on your purchase of a Sears Lawn Tractor. It has been designed, engineered and manufactured to give you the best possible dependability and performance. Should you experience any problem you cannot easily remedy, please contact your nearest Sears Service Department. We have competent, well-trained technicians and the proper tools to service or repair this unit.

**MAINTENANCE AGREEMENT**

A Sears Maintenance Agreement is available on this product. See the nearest Sears store or service center for details.

**CUSTOMER RESPONSIBILITIES**

Read and retain this manual. Study and observe the safety rules. Always use care when using your tractor. Always keep your tractor and mower clean. Follow a regular schedule in maintaining, caring for, and using your tractor. A well cared for tractor will run better and last longer.

**ATTACHMENTS**

This unit can use many attachments now available at your Sears store. It cannot use attachments that engage the ground like a plow, harrow, cultivator, or tiller.

SERIAL NUMBER \_\_\_\_\_

DATE OF PURCHASE \_\_\_\_\_

THE SERIAL NUMBER WILL BE FOUND ON THE MODEL PLATE UNDER THE SEAT.

YOU SHOULD RECORD THESE NUMBERS AND KEEP FOR FUTURE REFERENCE.

**LIMITED TWO YEAR WARRANTY ON ELECTRIC START RIDING EQUIPMENT**

For two years from date of purchase, when this riding equipment is maintained, lubricated, and tuned up according to the operating and maintenance instruction in the owner's manual. Sears will repair free of charge any defect in material or workmanship in this electric start riding equipment

This warranty excludes blade(s), blade adapter(s), spark plug(s), air cleaner(s) and belt(s) which are expendable and become worn during normal use

This warranty does not cover:

Tire replacement or repair caused by punctures from outside objects (such as nails, thorns, stumps or glass); and repairs necessary because of operator abuse or negligence, including the failure to maintain the equipment according to instructions contained in the owner's manual; and riding equipment used for commercial or rental purposes

**FULL 90-DAY WARRANTY ON BATTERY**

For 90 days from the date of purchase, if any battery included with this riding equipment proves defective in material or workmanship and our testing determines the battery will not hold a charge, Sears will replace the battery at no charge.

WARRANTY SERVICE IS AVAILABLE BY CONTACTING THE NEAREST SEARS SERVICE CENTER/DEPARTMENT IN THE UNITED STATES. This warranty applies only while this product is in use in the United States

This warranty gives you specific legal rights, and you may also have other rights which may vary from state to state.

SEARS, ROEBUCK and CO., D/698-731A, Sears Tower, Chicago, IL 60684

# INDEX

<b>A</b>		<b>F</b>		<b>P</b>	
Adjustments:		Filter .....	16	Parking Brake .....	10
Brake .....	14	Fuel:		Parts Bag .....	5-6
Carburetor .....	18	Type .....	10		
Mower Drive Belt .....	22	Storage .....	23		
Mower		Fuse .....	20		
Front-to-Rear .....	23			<b>R</b>	
Side-to-Side .....	22			Repair and Adjustments.....	14-23
Throttle Control Cable .....	18			Blade .....	15
Air Filter				Carburetor .....	18
Cleaning .....	16	<b>H</b>		Fuse .....	20
Element .....	16	Hood Removal .....	20	Hood Removal .....	20
Air Intake Screen, Engine .....	16			Motion Drive Belt	
Assembly .....	5-8			Replacement .....	19
		<b>L</b>		Mower Drive Belt	
		Levelling Mower Deck.....	22	Replacement .....	22
		Lubrication:		Mower Adjustment	
		Chart .....	17	Side-to-Side .....	22
		Tractor Pivot Points .....	17	Mower Removal .....	20
<b>B</b>					
Battery:		<b>M</b>		<b>S</b>	
Charging .....	7	Maintenance.....	13	Safety Rules .....	2
Cleaning .....	15	Air Filter .....	16	Seat .....	7
Installation .....	8	Air Filter Element .....	16	Service Record .....	13
Levels .....	7	Air Screen .....	16	Slope Guide Sheet .....	47
Preparation .....	7	Battery .....	15	Spark Plugs .....	18
Starting with Weak Battery .....	17	Blade Sharpening .....	14	Speed Control Chart .....	12
Storage .....	23	Brake Adjustment .....	14	Starting the Engine .....	10
Terminals .....	15	Engine Oil .....	16	Steering Wheel .....	5
Belt:		Lubrication Chart .....	17	Stopping the Tractor .....	10
Motion Drive Replacement .....	19	Spark Plugs .....	18	Storage .....	23
Mower Drive Adjustment .....	22	Tire Care .....	14		
Mower Drive,					
Remove Replace .....	22	Mower:		<b>T</b>	
Blade:		Adjustment, Front-to-Rear .....	23	Throttle Control Cable	
Sharpening .....	14	Adjustment, Side-to-Side .....	22	Adjustment .....	18
Replacement .....	14	Blade Sharpening .....	14	Tires .....	14
Brake Adjustment .....	14	Blade Replacement .....	14	Trouble Shooting Chart.....	24-25
		Cutting Level .....	22		
		Installation .....	21		
		Operation .....	11		
		Removal .....	20		
<b>C</b>		Muffler.....	17		
Carburetor Adjustment.....	18	Spark Arrester .....	2		
Controls, Tractor .....	9			<b>W</b>	
Cutting Level, Mower .....	22			Warranty .....	3
				Wiring (Schematic) .....	27
<b>E</b>		<b>O</b>			
Engine:		Oil			
Air Screen .....	17	Cold Weather Conditions .....	16		
Oil Change .....	16	Engine .....	16		
Oil Level .....	16	Storage .....	23		
Oil Type .....	16	Operation .....	9-12		
Starting .....	10	Operating Your Mower .....	11		
Storage .....	23	Operating Your Tractor .....	11		
		Starting the Engine .....	10		
		Stopping Your Tractor .....	10		
		Tractor Operation on Hills .....	12		

# ASSEMBLY

## 1. Unpack Tractor

- Take items out of box. The box contains the items shown below.
- Cut down four corners of the carton with a utility knife and fold down sides.
- Disengage Parking Brake.
- Install Steering Wheel
 

NOTE: POSITION FRONT WHEELS FORWARD

  - Remove 1/2" locknut and 2-1/4" dia. washer (shown full size below) from steering shaft (Fig. 1).
  - Position steering column into dashboard (Fig. 1).
  - Install steering wheel adapter on steering shaft.
  - Position steering wheel on steering wheel adapter with spokes pointed horizontal left to right.
  - Secure steering wheel to steering shaft using 2-1/4" dia. washer and hex locknut.

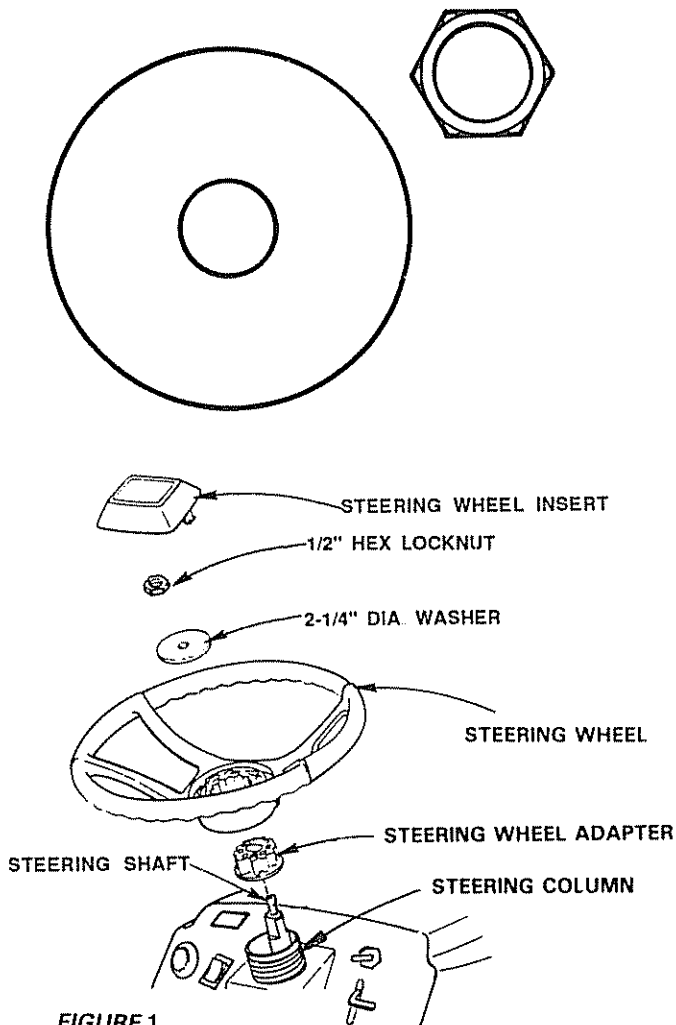
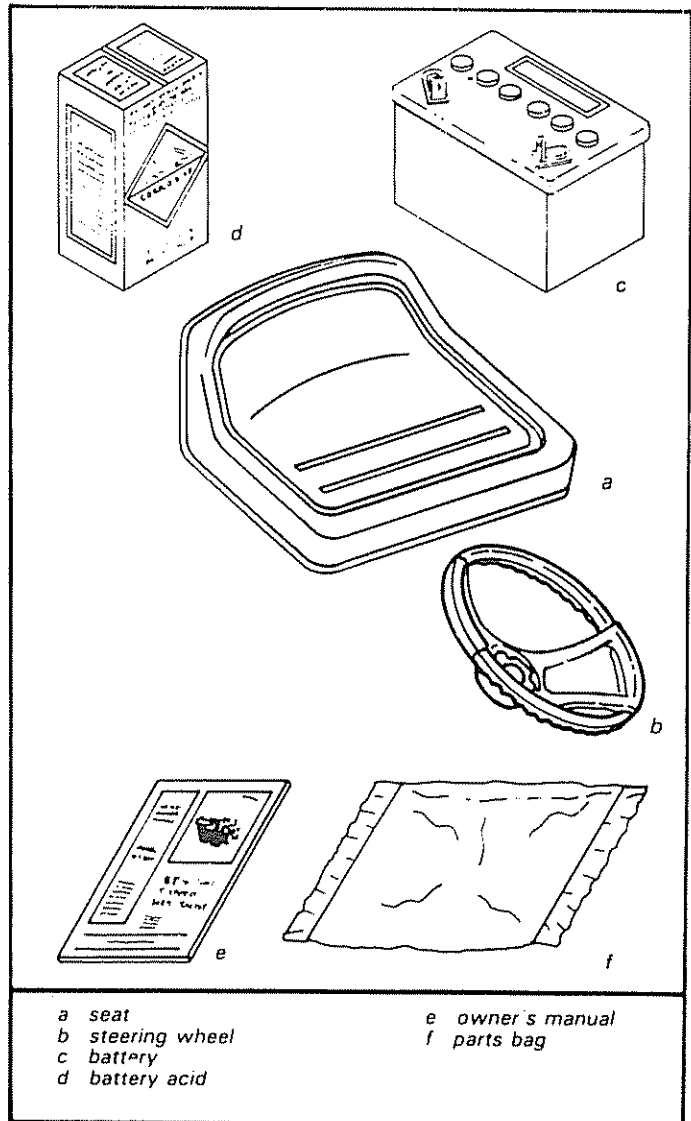

FIGURE 1







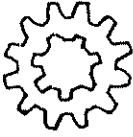

- Snap steering wheel insert into place on steering wheel. Steering column, adapter and insert found in bag of parts.

- Remove plastic on tractor hood.
- Raise attachment lift handle.
- Carefully guide the tractor off the skid.

The operation of any tractor can result in foreign objects thrown into the eyes, which can result in severe eye damage. Always wear safety glasses or eye shields before starting your tractor and while moving. We recommend Wide Vision Safety Mask for over the spectacles or standard safety glasses, available at Sears Retail or Catalog Stores.

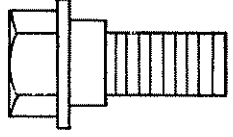
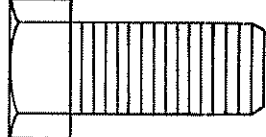
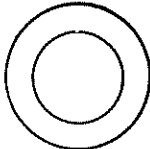

# ASSEMBLY

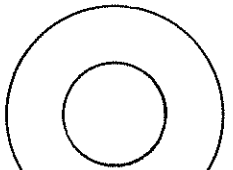
ASSEMBLY LOCATION	PARTS BAG CONTENTS SHOWN FULL SIZE		
<p><b>BATTERY</b></p>	 (2) Lockwasher, 1/4 Int/Ext Tooth	 (2) Wing Nut - 1/4 - 20	
<p><b>BATTERY TERMINALS</b></p>	 (2) Hex Bolt, 1/4 - 20 x 3/4	  (2) Lockwasher 1/4 (2) Washer 9/32 x 5/8 x 16 Ga.	 (2) Hex Nut, 1/4 - 20
<p><b>SEAT</b></p>	 (1) Shoulder Bolt 5/16 - 18  (1) Hex Bolt 1/2 - 13 x 1	 (1) Washer 15/32 x 1 x 16 Ga.  (1) Lockwasher 1/2	 (1) Washer 17/32 x 1-3/16 x 12 Ga.

Parts Bag Contents Not Shown Full Size:



(2) Battery Carriage Bolts - 1/4 - 20 x 7 - 1/2

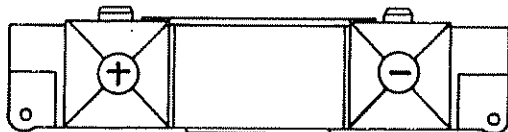

Terminal Guard

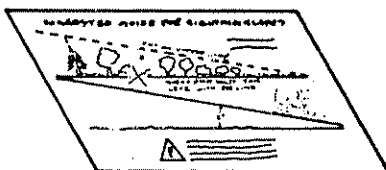

15° Slope Instruction Sheet

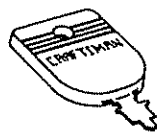

(2) Keys

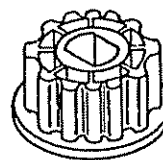

Steering Wheel Adapter

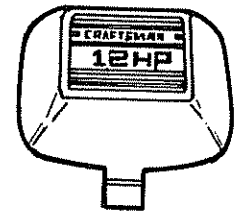

Steering Wheel Insert

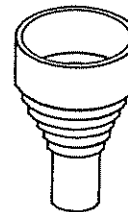

Steering Column

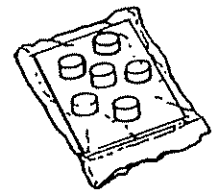

(6) Battery Caps And Instructions

# ASSEMBLY

To assemble tractor you will need:

- |                    |                     |
|--------------------|---------------------|
| (2) 7/16" Wrenches | Tire Pressure Gauge |
| (1) 1/2" Wrench    | Screwdriver         |
| (1) 3/4" Wrench    | Utility Knife       |

NOTE: RIGHT HAND (R.H.) AND LEFT HAND (L.H.) ARE DETERMINED FROM OPERATOR'S POSITION WHILE SEATED ON THE TRACTOR.

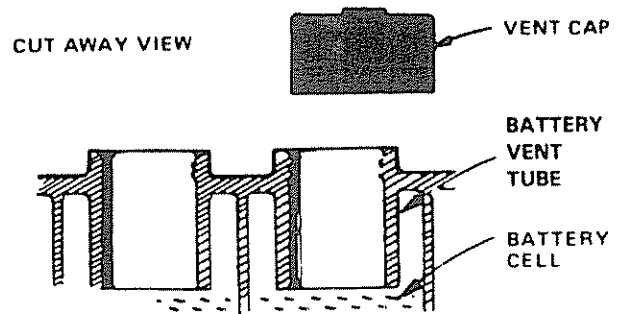

FIGURE 2

**WEAR EYE AND FACE SHIELD.**

**WASH HANDS OR CLOTHING IMMEDIATELY IF ACCIDENTALLY IN CONTACT WITH BATTERY ACID.**



**DO NOT SMOKE; FUMES FROM CHARGED BATTERY ACID ARE EXPLOSIVE.**

**READ THE INSTRUCTIONS INCLUDED WITH THE BATTERY VENT CAPS IN THE BAG OF PARTS. ALWAYS WEAR GLOVES, CLOTHING AND GOGGLES TO PROTECT YOUR HANDS, SKIN AND EYES.**

container. Stir with a wooden or plastic paddle while adding baking soda until the addition of more soda causes no more foaming.

- Use a 12 volt battery charger. Charge battery at a rate of 6 amperes for 1 hour. NOTE: OBSERVE SAFETY PRECAUTIONS, LISTED IN BOX ABOVE, REQUIRED FOR BATTERY CHARGING. Check the acid level after the battery is charged. If the acid has fallen below the correct level, add distilled or iron free water.

### 3. Install Seat.

Seat position should be adjusted forward or backward so that the operator can comfortably reach Clutch/Brake Pedal and safely operate tractor. (Fig. 3)

- Fill each cell with battery acid. Add the acid until it reaches the bottom of the vent tubes (Fig. 2). Do not add the acid beyond this level or the additional acid can come out when the battery is charged.
- After cells are filled, tilt battery from side to side to release air bubbles.
- Allow battery to stand and settle for at least thirty minutes. If the level of acid falls below the point described in step (a), add more acid until the correct level is reached. Install the battery caps, found in the bag of parts, to cover the vent tubes. Wash the top of the battery with water to remove any acid, then wipe dry.
- Check battery case for leakage to make sure that no damage has occurred in handling.
- Neutralize excess battery acid for disposal by adding it to four inches of water in a five gallon plastic

- Place Seat on Seat Pan. Screw Hex Head Machine Screw, Lockwasher and Flat Washer Assembly into Seat (Fig. 3). Screw Shoulder Bolt and Flat Washer Assembly into Seat (Fig. 3). Machine Screw, Shoulder Bolt and Washers found in Bag of Parts. (shown full size on pg 6).

- Tighten Shoulder Bolt and Flat Washer Assembly using a 1/2" wrench.

- Tighten Machine Screw, Lockwasher and Flat Washer Assembly using a 3/4" Wrench.

- Place Seat in operating position. Sit on the Seat and press Clutch/Brake Pedal all the way down. If operating position is not comfortable adjust Seat.

- To adjust: Raise Seat. Loosen Machine Screw Assembly. Slide Seat to desired position. Tighten Machine Screw Assembly securely.



**THE MACHINE SCREW-LOCKWASHER-FLAT WASHER ASSEMBLY MUST BE TIGHTENED SECURELY TO PREVENT MOVEMENT OF SEAT.**

# ASSEMBLY

## 4. Check Tires

Check the air pressure in the tires. Tires with too much air pressure will cause the unit to ride rough. The wrong air pressure will also keep the mower from cutting level. The correct air pressure is shown on the side of the tires. If the air pressure is not shown, set to pressures shown in the REPAIR AND ADJUSTMENT section. (page 14).

## 5. Install Battery



**BEFORE INSTALLING BATTERY, REMOVE METAL BRACELETS, WRISTWATCH BANDS, RINGS, ETC. FROM YOUR PERSON. TOUCHING THESE ITEMS TO BATTERY TERMINALS COULD RESULT IN BURNS.**

- a. Lift seat (Fig. 3).
- b. Lower battery into fender well with battery terminals toward front of tractor (Fig. 3). Make sure battery rests in battery tray. (Fig. 4)

**NOTE: BE SURE BATTERY DRAIN TUBE IS SECURELY ATTACHED TO BATTERY TRAY DRAIN.**



**POSITIVE TERMINAL MUST BE CONNECTED FIRST TO PREVENT SPARKS FROM ACCIDENTAL GROUNDING.**

- c. Connect **RED** battery cable to positive (+) battery terminal with hex bolt, flat washer, lockwasher and hex nut (shown full size on pg. 6) found in bag of parts. Tighten securely with two 7/16" wrenches. (Fig. 4)
- d. Connect **BLACK** ground cable to negative (-) battery terminal with remaining hex bolt, flat washer, lockwasher and hex nut (shown full size on pg. 6) found in bag of parts. Tighten securely. (Fig. 4)
- e. To prevent corrosion, apply grease to the battery terminals after installing cables.
- f. Using the key hole on one side of the battery support (Fig. 6) slide battery bolt into frame key hole (head of bolt down). Fasten the battery bolt to the terminal guard using internal/external lockwasher, wing nut, (shown full size on pg. 6) as shown in Fig. 5.
- g. Assemble the remaining battery bolt to other side of battery support and fasten terminal guard to it with remaining internal/external lockwasher and wing nut, (Shown full size on pg. 6). Tighten wing nuts securely by hand (Fig. 5).

**NOTE: KEEP TERMINAL ACCESS DOORS CLOSED WHEN NOT IN USE.**

**CAUTION: DO NOT START ENGINE UNTIL YOU HAVE REVIEWED THE OPERATION SECTION OF THIS MANUAL.**

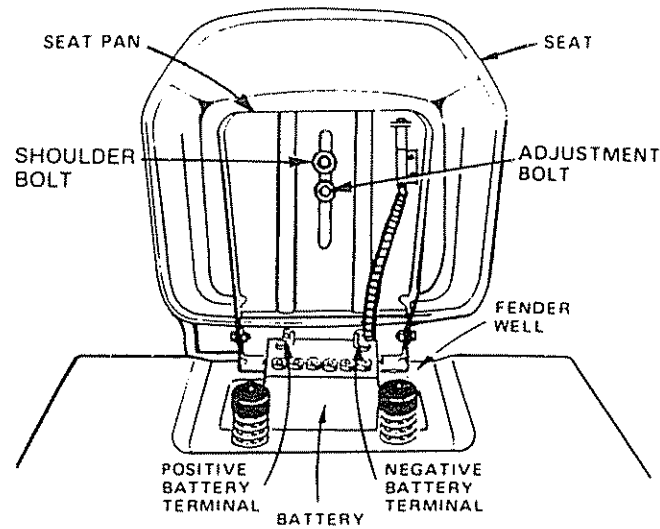

FIGURE 3

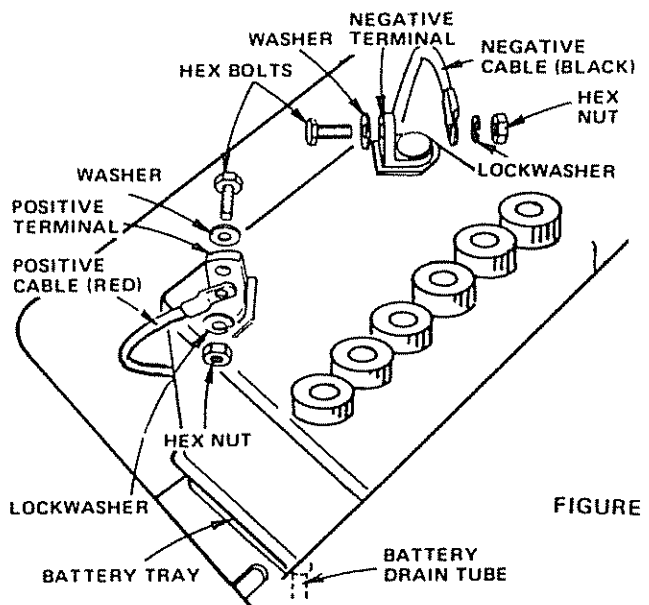

FIGURE 4

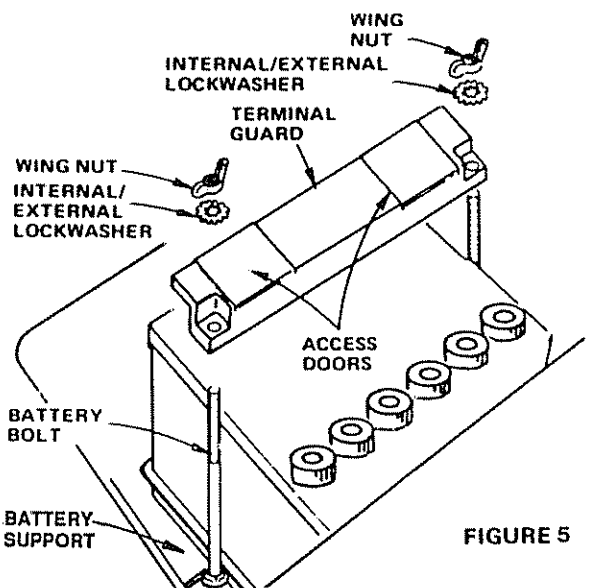

FIGURE 5

**6. Maintenance After First 2 Hours (Two Mowings)**  
Changing oil after the first two hours (or two mowings) will help eliminate break-in residue which might be damaging your engine.



# OPERATION

## KNOW YOUR TRACTOR

**READ THIS OWNER'S MANUAL BEFORE OPERATING YOUR LAWN TRACTOR.** If you understand the unit and its operation, you will achieve efficient and peak performance. While reading the manual, compare the illustrations with your Lawn Tractor to familiarize yourself with the location of various controls and adjustments. Study the operating instructions and safety precautions thoroughly to insure proper functioning of your Lawn Tractor and to prevent injury to yourself and others. Be sure to pay strict attention to all warnings and cautions: they are included for your safety. Save this manual for future reference.

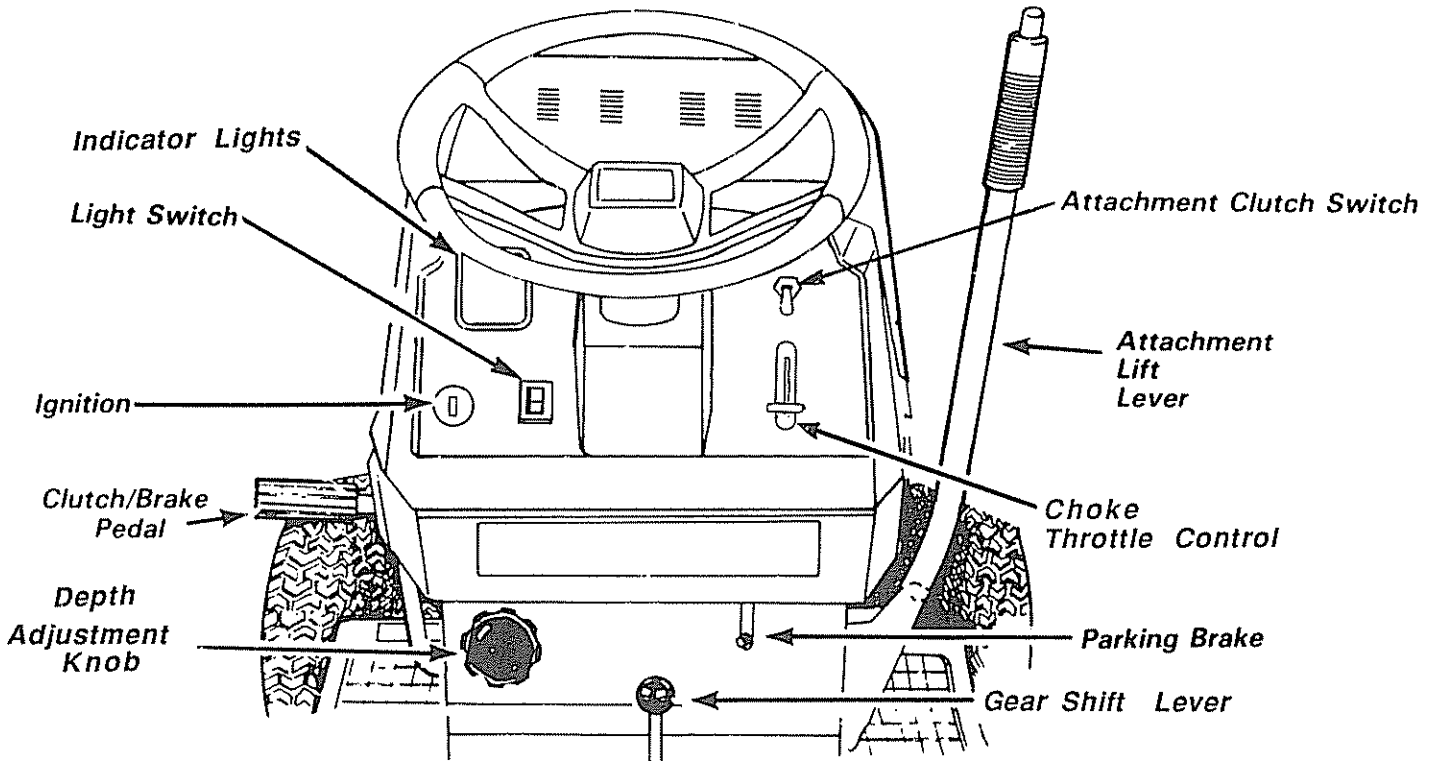

**ATTACHMENT LIFT LEVER:** Use the attachment lift lever to raise and lower the attachment mounted to your tractor. Pull lever back slightly and push button, then move the lift lever forward to lower attachment.

**ATTACHMENT CLUTCH SWITCH:** Pull switch out and up to engage attachment. There will be an engine hesitation as the clutch engages.

**CHOKER:** To start a cold engine, engage choke by moving throttle control lever to "FAST" detent, then right & upward to "CHOKER" position.

**CLUTCH/BRAKE PEDAL:** The pedal has 2 functions; a clutch and a brake. To engage the brake push the pedal completely down.

**DEPTH ADJUSTMENT KNOB:** Use the height adjustment knob to adjust the mower height. With the attachment lift lever in the "up" position, turn knob clockwise (↻) to raise cutting height and counterclockwise (↺) to lower cutting height.

**GEARSHIFT:** Press the clutch/brake pedal down firmly and move gear shift lever to desired speed.

**INDICATOR LIGHTS:** "DEPRESS FOOT PEDAL" indicates that the clutch/brake pedal must be depressed before the engine will start. "DISENGAGE ATTACHMENT" indicates that the attachment must be disengaged before the engine will start. "BATTERY DISCHARGING" indicates there is insufficient battery charging.

**IGNITION:** Place key in ignition and turn to the right to start. The switch spring returns from the start position.

**LIGHT SWITCH:** Turns the headlights on and off.

**PARKING BRAKE:** To set the parking brake, push the clutch/brake pedal completely down. Hold the parking brake lever in "Engaged" position and release pressure from pedal. Clutch/brake pedal will remain in brake position.

**THROTTLE CONTROL:** Use the throttle control to increase or decrease the speed of the engine.

# OPERATION

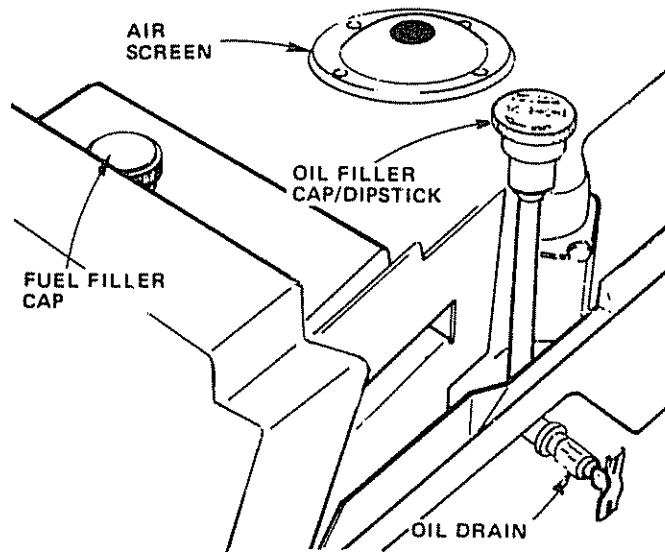

FIGURE 6

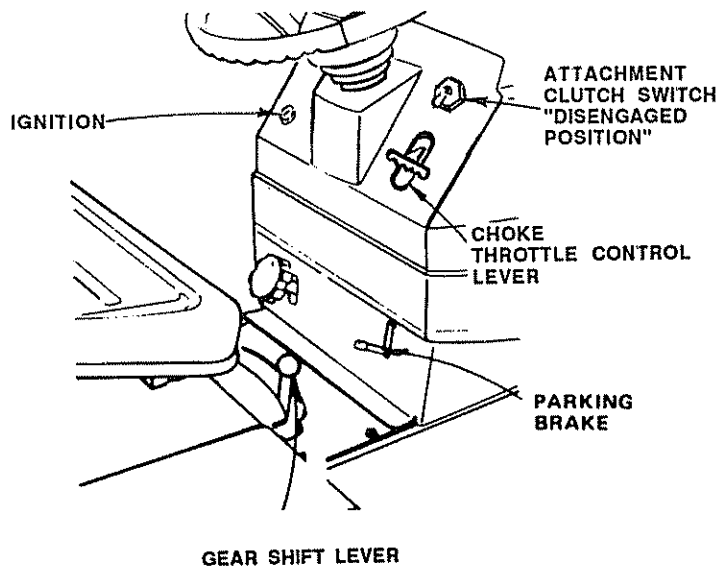

FIGURE 7

## 1. Stopping Your Tractor

NOTE: REMOVE KEY WHEN LEAVING TRACTOR TO PREVENT UNAUTHORIZED USE.

- Push clutch-brake pedal into full "BRAKE" position. Keep your foot on pedal.
- Place attachment clutch switch in "DISENGAGED" Position.
- Move gear shift lever to "NEUTRAL" position.
- Place parking brake in "ENGAGED" position and release pressure from clutch/brake. Pedal should remain in "BRAKE" position.
- Move throttle control to "S" (slow) position.
- Turn ignition key to "OFF" position. Never use choke to stop engine.

## 2. Preparing The Engine



**LEARN TO START, STOP AND REVERSE YOUR TRACTOR IN A LARGE, OPEN AREA.**

- This engine has been shipped filled with summer weight oil (For cold weather operation see chart page 16). Check engine oil level. Refer to REPAIR AND ADJUSTMENT section. (page 16).
- Fill fuel tank (Fig. 6). Use fresh, clean, regular unleaded gasoline. Capacity is 5 quarts.



**FILL TO BOTTOM OF GAS TANK FILLER NECK. DO NOT OVERFILL. WIPE OFF ANY SPILLED OIL OR FUEL. DO NOT STORE, SPILL OR USE GASOLINE NEAR AN OPEN FLAME.**

## 3. Starting The Engine

- Move throttle control lever (Fig. 7) past "FAST" to the "CHOKE" position.
- Turn ignition key to "START" and release key as soon as engine starts.

CAUTION: DO NOT RUN STARTER CONTINUOUSLY FOR MORE THAN FIFTEEN SECONDS PER MINUTE.

- If engine does not start after four or five tries, move throttle control lever to "FAST" position, wait a few minutes and try again. If the engine does not start after four or five more tries, see the TROUBLESHOOTING Chart. (page 24).

# OPERATION

- d. After the engine starts move throttle control lever slowly to the "SLOW" position.
- e. To start a hot engine move the throttle control lever to a position between "FAST" and "SLOW".



**READ THE "SAFETY RULES" CAREFULLY BEFORE OPERATING YOUR MOWER.**

**CAUTION: DO NOT ADD ADDITIONAL WEIGHT TO THE TRACTOR OTHER THAN THE OPTIONAL WHEEL WEIGHTS. EXCESSIVE WEIGHT MAY OVERLOAD AND DAMAGE THE TRANSMISSION.**



**ALWAYS WEAR SUBSTANTIAL FOOTWEAR AND AVOID LOOSE FITTING CLOTHING THAT COULD GET CAUGHT IN MOVING PARTS.**



## **CAUTION TO AVOID INJURY**

1. Read owner's manual.
2. Know location and function of all controls.
3. Keep guards, safety shield and switches in place and working.
4. Remove objects that can be thrown by blades.
5. Do not mow when children and others are around.
6. Never carry children or passengers.
7. Always look behind machine before backing.
8. Do not mow where machine can tip or slip.
9. If machine stops going uphill, stop blades and back slowly down.
10. Be sure blades and engine have stopped before placing hands or feet near the blades.
11. Remove key when leaving machine.

**MAKE SURE PARKING BRAKE WILL HOLD TRACTOR SECURE.**



**NEVER PLACE YOUR HANDS OR FEET IN OR UNDER ANY POWERED ATTACHMENT OR NEAR ANY MOVING PART WHILE TRACTOR OR ANY POWERED ATTACHMENT IS RUNNING.**

## **4. Operating Your Lawn Tractor & Mower**



**DO NOT OPERATE THE MOWER WITHOUT THE DEFLECTOR SHIELD (DISCHARGE GUARD) IN PLACE.**

**NOTE: THIS TRACTOR IS EQUIPPED WITH AN OPERATOR PRESENCE SENSING SWITCH. ANY ATTEMPT BY THE OPERATOR TO LEAVE THE SEAT WITH THE ENGINE RUNNING AND THE ATTACHMENT CLUTCH SWITCH ENGAGED WILL SHUT OFF THE ENGINE.**

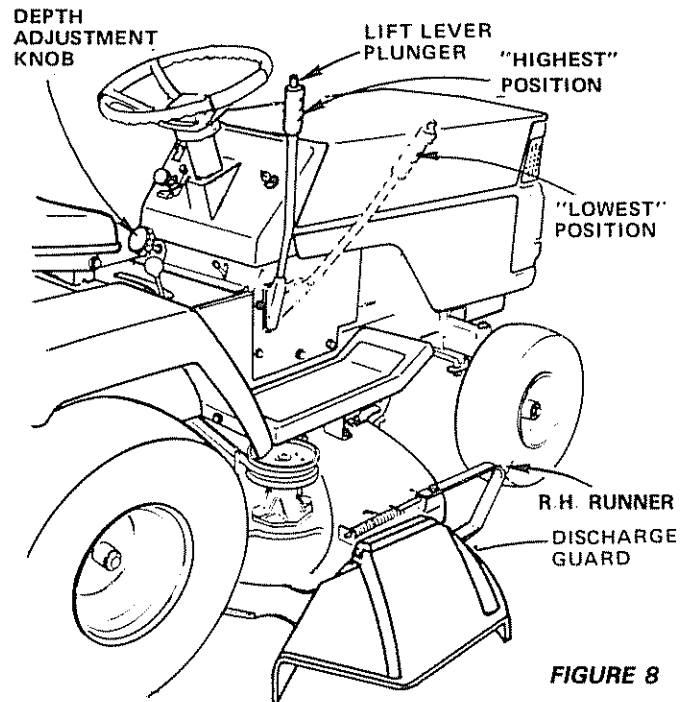

**FIGURE 8**

- a. Move the attachment lift lever to the high position and adjust height of cut to mid range. See Fig 8.
- b. Start the engine. (See Starting the Engine)
- c. Move the throttle lever to mid range position. Select a low (1st or 2nd) gear until you become more familiar with the operation of the unit.
- d. Slowly release clutch brake pedal and proceed to the mowing area.
- e. Stop the unit, then select a mowing speed. (See Speed Selection Guide page 12).
- f. Move throttle lever to half throttle and move attachment clutch switch to engaged position.
- g. Slowly release clutch brake pedal.
- h. Move throttle lever to fast position.
- i. Observe height of cut and readjust as desired.

**CAUTION: BEFORE YOU MOVE THE GEAR SHIFT LEVER, COME TO A COMPLETE STOP. FAILURE TO DO SO CAN RESULT IN GEAR BOX DAMAGE.**

# OPERATION

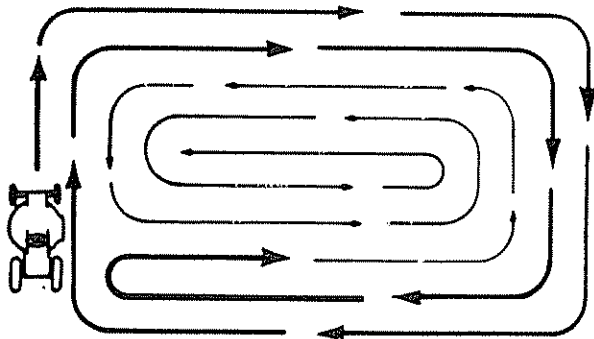

FIGURE 9

SPEED SELECTION GUIDE		
FUNCTION	GEARSHIFT	THROTTLE
Normal Mowing	2 or 3	
Heavy Mowing	1 or 2	
Snow Blowing	1	FAST
Snow Blade	2	
Transport	4-6	

## 5. Mowing Tips

NOTE: TIRE CHAINS CANNOT BE USED WITH THE MOWER ATTACHED.

- Mower should be adjusted properly front to back and side to side for good mowing performance. Refer to REPAIR AND ADJUSTMENT section. (page 22).
- Use the runner on the R.H. side as a guide; the blade cuts approximately an inch outside the runner (Fig. 8).
- Drive so that clippings are discharged onto the area that has been cut. Have the cut area to the right of the machine. This will result in a more even distribution of clippings and more uniform cutting.
- When mowing large areas (Fig. 9), start by turning to the right so that the clippings will discharge away from shrubs, fences, driveways, etc. After two or three rounds, mow in the opposite direction making left hand turns until finished.
- If grass is extremely tall, it should be mowed twice. The first time cut relatively high; the second time to the desired height.
- The left hand side of mower should be used for trimming.
- See Speed Selection Guide.

## 6. Operating The Tractor On Hills



**DO NOT DRIVE UP OR DOWN HILLS WITH SLOPES GREATER THAN 15° AND DO NOT DRIVE ACROSS ANY SLOPE. REFER TO PAGE 43.**

- Move gear shift lever to "1st" gear before starting up or down hills.
- AVOID STOPPING OR SHIFTING ON HILLS.
- If slowing is necessary, move throttle control lever to slower position.



**LEAVE ENOUGH ROOM WHEN STOPPING AND STARTING TO ALLOW SLIGHT TRACTOR ROLL DOWNHILL AS CLUTCH-BRAKE PEDAL MOVES THROUGH CLUTCH POSITION.**

- If stopping is absolutely necessary, push clutch/brake pedal quickly to brake position.
- To restart tractor movement, make sure tractor is in the lowest speed range ("1st" Gear) and release clutch-brake pedal SLOWLY.
- Make all turns gradually.

# MAINTENANCE

To keep your tractor running better, longer, perform necessary service using the following maintenance schedule:

**With Every Mowing**

1. Make sure all nuts on bolts are tight and cotter pins and retainer springs are secure.
2. Observe all safety precautions.
3. Keep tractor well lubricated (refer to page 17).



**BEFORE MAKING ANY INSPECTION, ADJUSTMENT, OR REPAIR:**

1. PUSH CLUTCH/BRAKE PEDAL COMPLETELY DOWN.
2. MOVE GEAR SHIFT CONTROL LEVER TO NEUTRAL POSITION.
3. PLACE PARKING BRAKE IN "ENGAGED" POSITION. REMOVE FOOT FROM PEDAL.
4. DISENGAGE ATTACHMENT CLUTCH SWITCH.
5. SHUT OFF THE ENGINE.
6. MAKE ABSOLUTELY SURE THE BLADES AND ALL MOVING PARTS HAVE COMPLETELY STOPPED.
7. DISCONNECT THE SPARK PLUG WIRE FROM THE SPARK PLUG AND KEEP WIRE AWAY FROM THE SPARK PLUG TO PREVENT INJURY FROM ACCIDENTAL STARTING. BE CAREFUL TO AVOID TOUCHING HOT ENGINE OR MUFFLER COMPONENTS.

## SERVICE RECORD

(Enter Date Maintenance Performed)

SERVICE RECORD	SCHEDULE							
	FIRST 2 HOURS	EVERY 5 HOURS	EVERY 25 HOURS	EVERY 50 HOURS	EVERY 100 HOURS			
Fill in dates as you complete regular service								
Blades - sharpen			✓					
Brake Adjustment			✓					
Check Battery				✓				
Change Engine Oil	✓			✓				
Check Engine Oil level		✓						
Clean Air Cleaner Element				✓				
Check Muffler				✓				
Clean Air Screen				✓				
Lubricate Tractor				✓				
Replace Spark Plug					✓			
Replace Air Cleaner Element					✓			
Check Tire Pressure			✓					

# REPAIR AND ADJUSTMENT

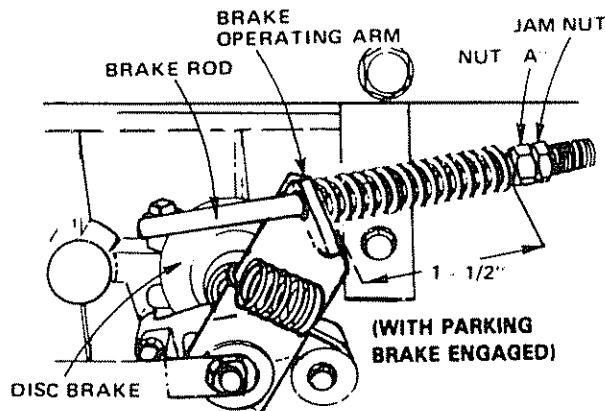

FIGURE 10

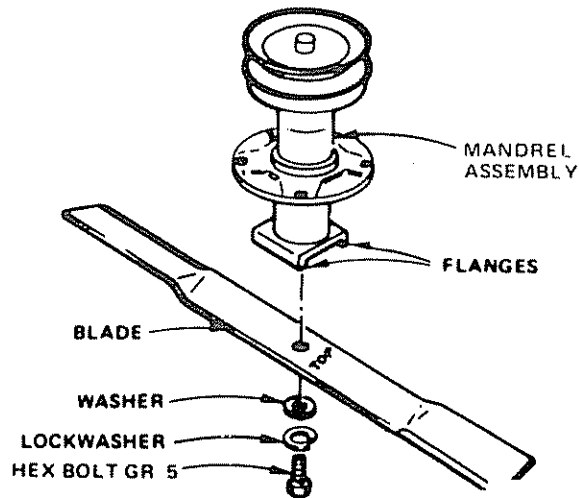
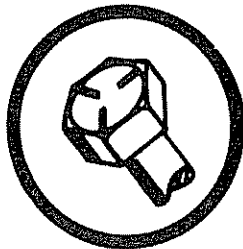

FIGURE 11



A GRADE 5 HEAT TREATED BOLT CAN BE IDENTIFIED BY THREE LINES ON THE BOLT HEAD AS SHOWN AT LEFT.

## 1. Brake Adjustment

This tractor is equipped with an adjustable brake system mounted on the right side of the transaxle (Fig. 10).



**IF TRACTOR REQUIRES MORE THAN SIX FEET STOPPING DISTANCE IN HIGHEST GEAR, THEN BRAKE MUST BE ADJUSTED.**

- Depress clutch/brake pedal and engage parking brake.
- Measure distance between brake operating arm and nut "A" on brake rod.
- If distance is other than 1-1/2", disengage parking brake, loosen jam nut (Fig. 10) and turn nut "A" until distance becomes 1-1/2", Retighten jam nut against Nut "A".

Road test tractor for proper stopping distance as stated above. Readjust if necessary.

## 2. Tire Care

Maintain tire pressure in front at 14 PSI and rear tires at 12 PSI.

## 3. Blade Care

For best results mower blades must be kept sharp. The blades can be sharpened with a few strokes of a file, or on a grinding wheel. We suggest they be sharpened after every 25 hours of mowing. Do not attempt to sharpen while on mower. If you mow in sandy soil check the blades after each two mowings. The sand wears the blade away rapidly.

### a. Blade Replacement

Raise mower to highest position to permit access to blades.

- Remove the hex head bolt, lockwasher and flat washer (Fig. 11) (turn counterclockwise) (↺).
- Remove and discard old blade.
- Clean top and bottom of mower housing.
- Install new blade with SHARP EDGE DOWN and secure with flat washer, lockwasher and hex head bolt. TIGHTEN SECURELY.



**ALWAYS USE GRADE 5 HEAT TREATED BOLTS TO ATTACH BLADES. DO NOT USE PLATED BOLTS. CHECK BOLTS IN BLADES OCCASIONALLY TO MAKE SURE BOLTS ARE TIGHT. TORQUE BOLTS TO 30 - 35 FT.- LBS.**

- When grinding, care should be taken to maintain blade balance and the blade should be checked for proper balance before reinstallation on mower. An unbalanced or bent blade will cause excessive vibration when running, and eventual damage to mower or engine. Replace bent or damaged blades.

# REPAIR AND ADJUSTMENT

- c. To check blade balance, drive a nail into a beam or wall. Leave about one inch of the straight nail exposed. Place center hole of clean blade over the head of the nail (Fig. 12). NOTE: CENTER HOLE OF BLADE ON NAIL, IF BLADE IS PROPERLY BALANCED, BLADE SHOULD REMAIN IN POSITION SHOWN IN FIG. 12. IF EITHER END OF THE BLADE MOVES DOWNWARD, BLADE IS NOT BALANCED. SHARPEN THE HEAVY END UNTIL BLADE IS BALANCED.

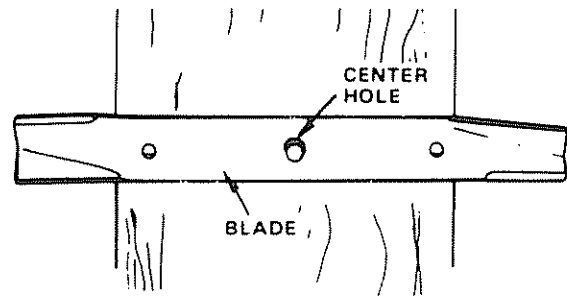

FIGURE 12

## 4. BATTERY CARE

### Check Battery

- a. Battery acid solution level in each battery cell should be even with bottoms of vent tubes in cells (Fig. 13). Add ONLY distilled or iron free water if necessary. NOTE: DO NOT OVERFILL.
- b. Keep battery and terminals clean.
- c. Keep battery bolts tight.
- d. Keep vent caps tight and small vent holes in caps open.
- e. Recharge at 6 amperes for 1 hour if necessary.

### Clean Battery and Terminals

Corrosion and dirt on the battery and terminals cause the battery to "leak" power and hinders the operation of the charger.



**LEAD-ACID BATTERIES GENERATE EXPLOSIVE GASES. KEEP SPARKS, FLAME AND SMOKING MATERIALS AWAY FROM BATTERIES. ALWAYS SHIELD YOUR EYES AROUND BATTERIES.**

- a. Remove terminal guard.
- b. Disconnect BLACK battery cable, then RED battery cable, and remove battery from tractor.
- c. Wash battery with four tablespoons of baking soda to one gallon of water. NOTE: BE CAREFUL NOT TO GET THE SODA SOLUTION INTO THE CELLS.
- d. Rinse the battery with plain water, dry and reinstall on tractor.
- e. Clean terminals and battery cable ends with wire brush until bright.
- f. Replace battery cables, connecting RED battery cable to positive terminal first, then BLACK battery cable to negative terminal. Coat terminal connections with vasoline after installation of cables.
- g. Replace terminal guard.

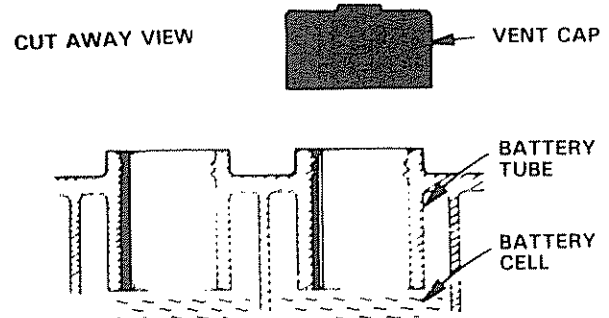

FIGURE 13

# REPAIR AND ADJUSTMENT

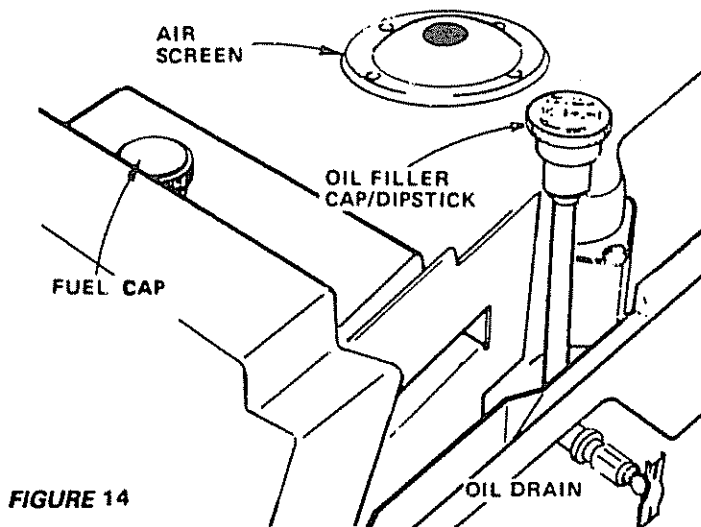

FIGURE 14

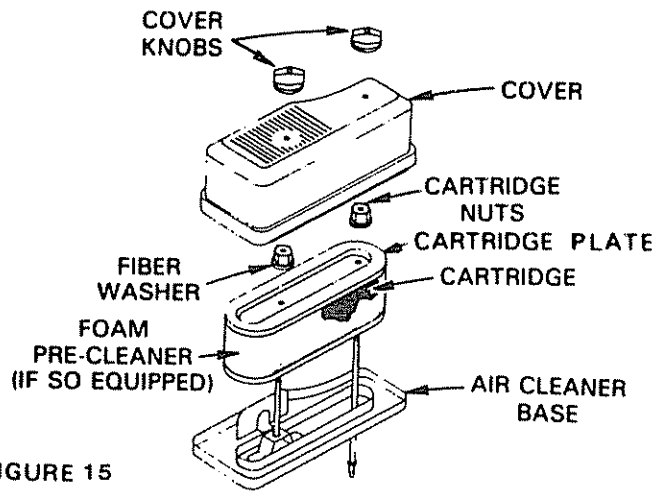

FIGURE 15

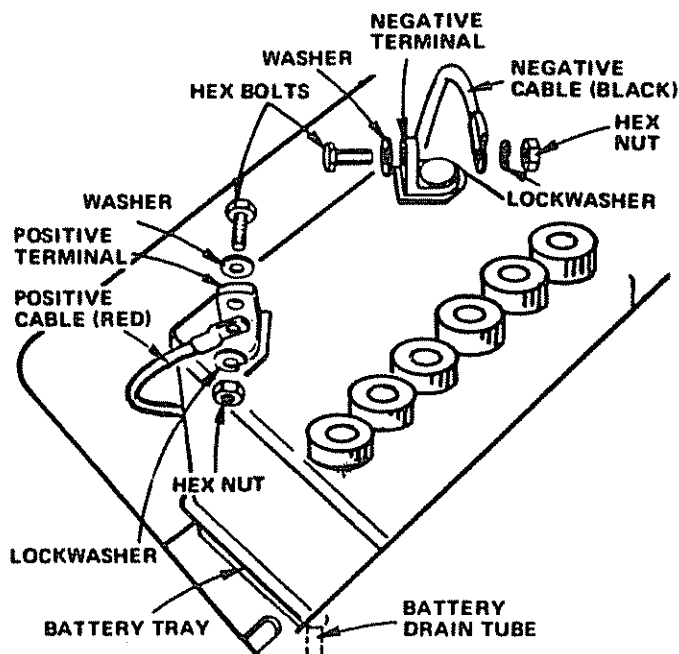

FIGURE 16

## 5. Change Engine Oil

The best time to change engine oil is at the end of a day's operation when all dirt and foreign materials are suspended in the hot oil.

Capacity is 1-1/2 quarts. NOTE: DO NOT OVERFILL. Dipstick assembly must be securely tightened into tube at all times when engine is operating.

**IMPORTANT: TO AVOID DAMAGE TO THE STARTING SYSTEM, USE SAE 5W30 OIL WHEN THE TEMPERATURE FALLS BELOW 32°.**

### Recommended SAE Viscosity Grades

Determine temperature range expected before next oil change. All oil must meet A.P.I. service classification SD, SE or SF.

- a. Open petcock to drain engine oil. Tighten petcock finger tight to close.
- b. Add oil through the oil filler cap/dipstick (Fig. 14).

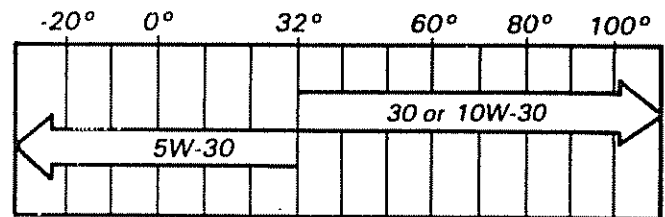

## 6. Check Engine Oil Level

**NOTE: DO NOT CHECK ENGINE OIL LEVEL WITH ENGINE RUNNING.**

Several minutes after stopping engine, check engine oil level with tractor on level ground. Wipe dipstick (Fig. 14) clean, screw it down tight for a few seconds, remove and read oil level. If necessary, add oil until "FULL" mark is reached. (See chart above). NOTE: DO NOT OVERFILL.

## 7. Clean Air Cleaner Element (Fig. 15)

- a. Remove two cover knobs and remove air cleaner cover.
- b. Remove foam pre-cleaner,
  - Wash pre-cleaner in liquid detergent and warm water to remove dirt.
  - Wrap pre-cleaner in cloth and squeeze dry.
  - Saturate foam in engine oil. Squeeze to remove excess oil.
- c. Remove two nuts from top of cartridge.
- d. Remove cartridge and clean air cleaner body carefully to prevent dirt from entering carburetor.
- e. Clean cartridge by gently tapping on flat surface. If very dirty, replace cartridge.
- f. Reassemble air cleaner.

NOTE: Nuts holding air cleaner cartridge must be installed with fiber washers down on cartridge plate to prevent dirt from entering carburetor. Tighten nuts by hand. Over tightening could collapse cartridge.

NOTE: NEVER RUN ENGINE WITH AIR CLEANER REMOVED.



# REPAIR AND ADJUSTMENT

## 8. Clean Air Screen



**ALWAYS WEAR EYE AND FACE PROTECTION WHEN USING COMPRESSED AIR.**

Air screen (Fig. 14) must be kept free of dirt and chaff to prevent engine damage from overheating. Clean with a wire brush or compressed air to remove dirt and dried gum fibers.

## 9. Check Muffler

Inspect and replace damaged muffler and/or deflector as it could create a fire hazard and/or damage.



**DO NOT TOUCH HOT MUFFLER, CYLINDER OR FINS AS CONTACT MAY CAUSE BURNS.**

## 10. Lubricate Pivot Points

Place several drops of SAE 30 oil at points where parts move against each other, especially:

- Front axle pivot
- Hood hinges
- Foot pedal shaft (both ends)
- Lift shaft (both ends)

## 11. Starting your Tractor With a Weak Battery

If your battery is too weak to start the engine, it should be recharged. If "jumper cables" are used for emergency starting, follow this procedure:

NOTE: YOUR TRACTOR IS EQUIPPED WITH A 12 VOLT NEGATIVE GROUND SYSTEM. THE OTHER VEHICLE MUST ALSO BE A 12 VOLT NEGATIVE GROUND SYSTEM.



**LEAD-ACID BATTERIES GENERATE EXPLOSIVE GASES. KEEP SPARKS, FLAME AND SMOKING MATERIALS AWAY FROM BATTERIES. ALWAYS WEAR EYE PROTECTION WHEN AROUND BATTERIES.**

- Connect each end of the RED cable to the POSITIVE (+) terminals of each battery (taking care not to short against chassis). (Fig. 16)
- Connect one end of the BLACK cable to the NEGATIVE (-) terminals of fully charged battery.
- Connect the other end of the cable to the L.H. side panel bolt (Fig. 17). NOTE: KEEP AWAY FROM GAS TANK AND BATTERY

## LUBRICATION CHART

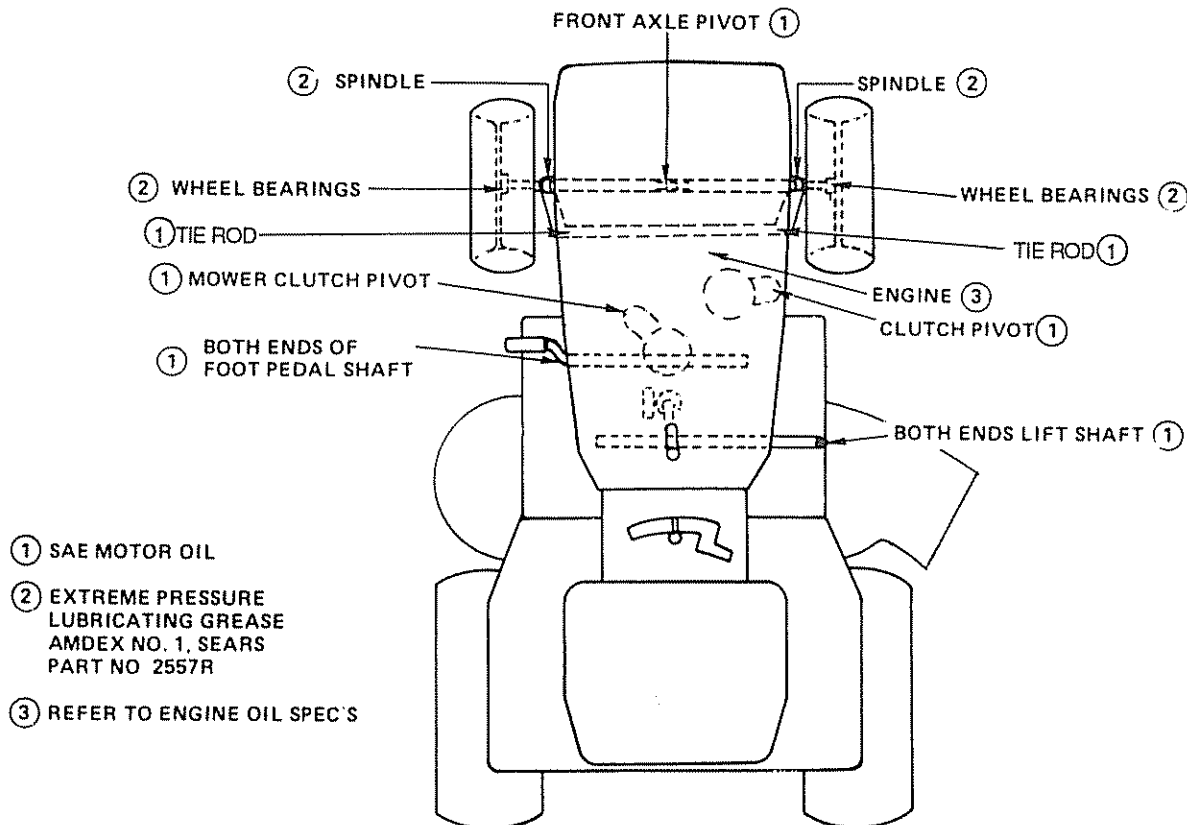

# REPAIR AND ADJUSTMENT

- d. Disconnect cables in reverse order:
1. L.H. Side Panel Bolt (Fig. 17)
  2. Negative terminals of fully charged battery
  3. Positive terminals

**DO NOT USE YOUR TRACTOR BATTERY TO START OTHER VEHICLES.**

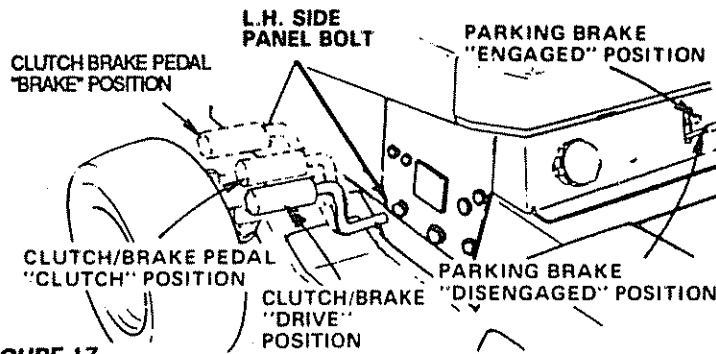

FIGURE 17

## 12. Throttle Control Cable Adjustment

Never attempt to change maximum engine speed. This is preset at the factory and should only be changed by a qualified service technician who has the necessary equipment. CAUTION: BEFORE ANY ENGINE ADJUSTMENT, MAKE SURE AIR CLEANER IS CLEAN. Remove Air Cleaner Assembly, while making adjustments.

- With engine off, place Throttle Control in "FAST" position.
- Loosen Clamp Screw (Fig. 18). Adjust Throttle Cable until holes "A" are aligned in governor control plate and slide plate.
- Tighten clamp screw.

## 13. Carburetor Adjustment

NOTE: ADJUST THROTTLE CONTROL CABLE BEFORE MAKING ANY ADJUSTMENT TO CARBURETOR.

- With engine off turn high speed mixture screw clockwise (↻) closing finger tight ONLY, and turn counterclockwise (↺) 1-1/2 turns (Fig. 18)

NOTE: THE SCREW SEAT MAY BE DAMAGED BY TURNING IT TOO FAR CLOCKWISE.

**REFER TO "STARTING THE ENGINE" PAGE 10.**

- Start engine and allow to warm for five minutes. Make final adjustment with engine running and Gear Shift lever in "NEUTRAL" position.

- With throttle control lever in "FAST" position, turn high speed mixture screw counterclockwise (↺) until engine runs "rough" then turn clockwise (↻) until engine begins to miss. Turn screw to a point midway between these positions.
- With throttle control lever in "SLOW" position, hold throttle lever so that idle stop screw is against carburetor, turn idle mixture Screw counterclockwise (↺) until engine runs "rough" and then turn clockwise until engine begins to die. Turn idle mixture screw to a point midway between these positions.
- With throttle control lever in "SLOW" position, engine should idle at 1750 RPM. If engine idles too slow, push throttle control lever above idle and turn idle speed screw one turn clockwise (↻). Set throttle control lever at "SLOW". Repeat until satisfactory idle is attained.
- If engine idles too fast with throttle control lever in "SLOW" position push throttle control lever above idle and turn idle speed screw one turn counterclockwise (↺). Set throttle control lever at "SLOW". Repeat until satisfactory idle is attained.

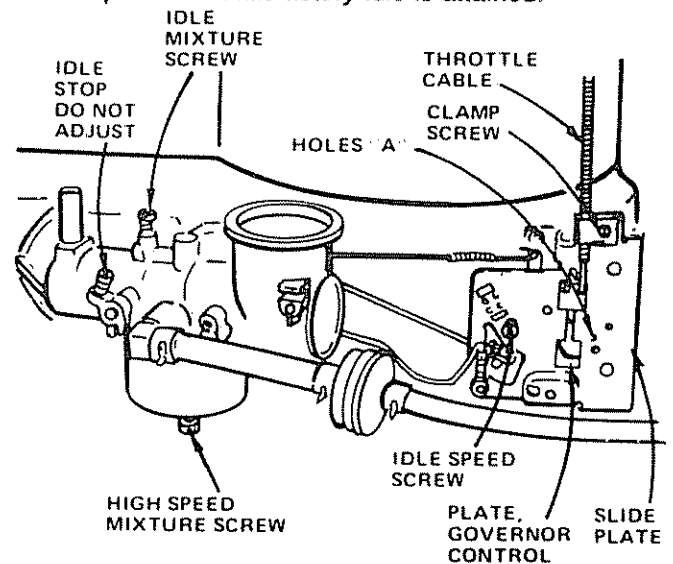

FIGURE 18

## 14. Replace Spark Plug

Replace spark plug at the beginning of each mowing season or every 100 hours, whichever comes first. Gap should be set at 0.030 inch (Fig. 19).

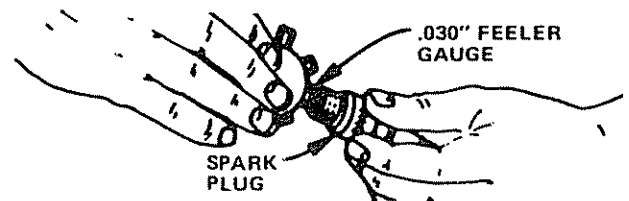

FIGURE 19

# REPAIR AND ADJUSTMENT

## 15. Motion Drive Belt Removal

The tractor drive belt may be replaced without tools. Park the tractor on level area. Engage parking brake. NOTE: A BELT INSTALLATION DECAL IS UNDER LEFT FOOTREST.

- a. Remove mower. (See mower section, Following pages).
- b. Remove two retainer springs from belt guide bracket below transaxle pulley. Remove bracket (Fig. 20).
- c. Swing belt guides away from belt, toward rear of tractor (Fig. 20).
- d. Roll belt over top of transaxle pulley.
- e. Roll belt over engine pulley and off idler (Fig. 22).
- f. Release parking brake. Pull belt as far as possible over top of clutch pulley.
- g. Reset parking brake. Pull belt over top of clutch pulley (Fig. 22).
- h. Pull belt out through shift gate to remove from tractor (Fig. 21).  
Install belt by reversing above procedure.

NOTE: REPLACE ONLY WITH BELT LISTED IN THIS MANUAL.

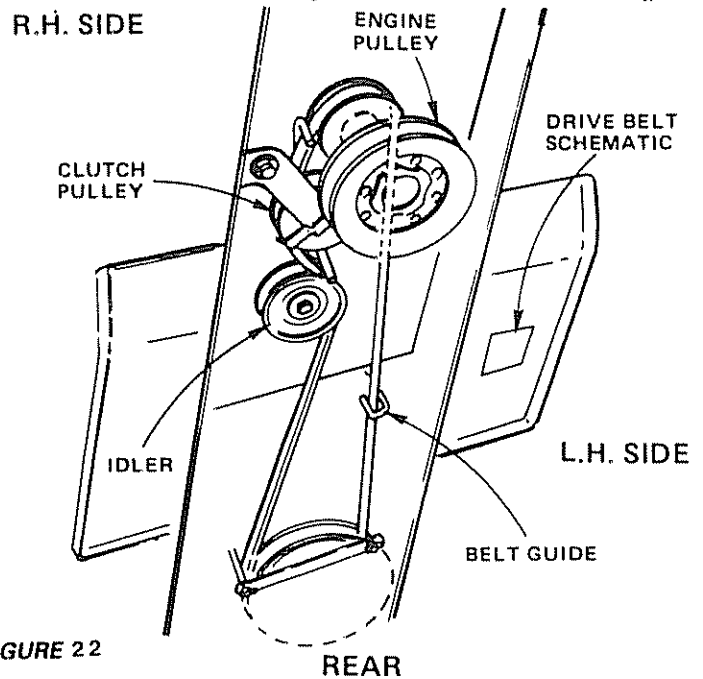
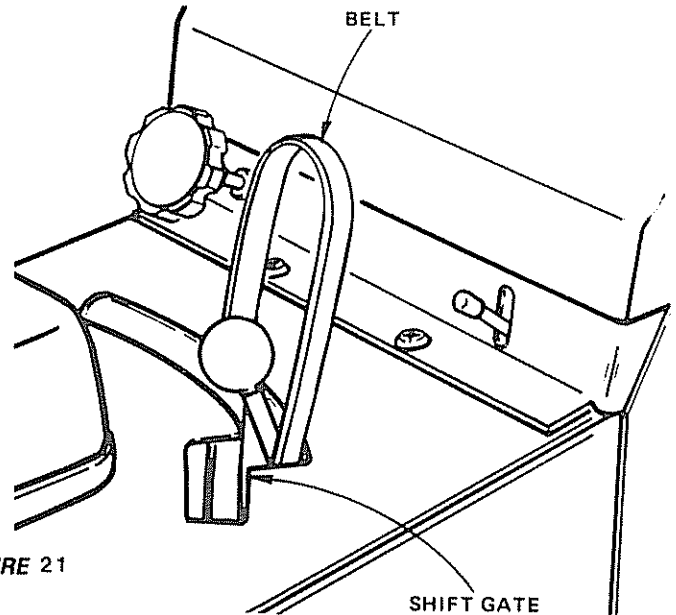
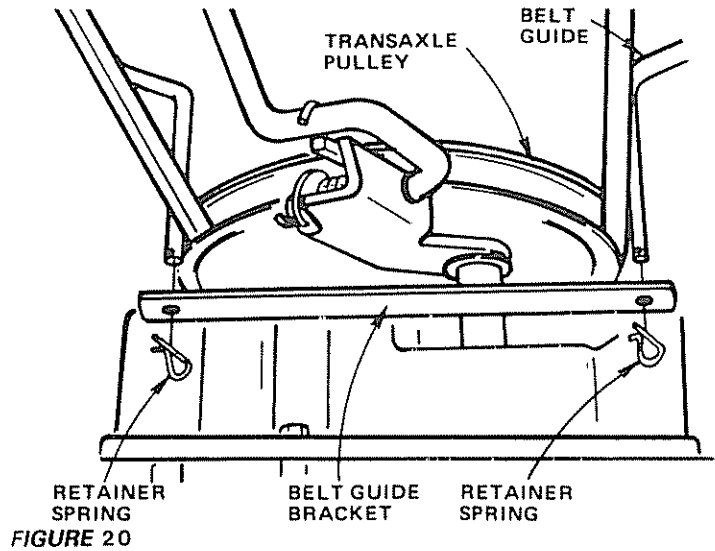

19 FIGURE 22  
REAR  
VIEWED FROM BOTTOM OF TRACTOR

# REPAIR AND ADJUSTMENT

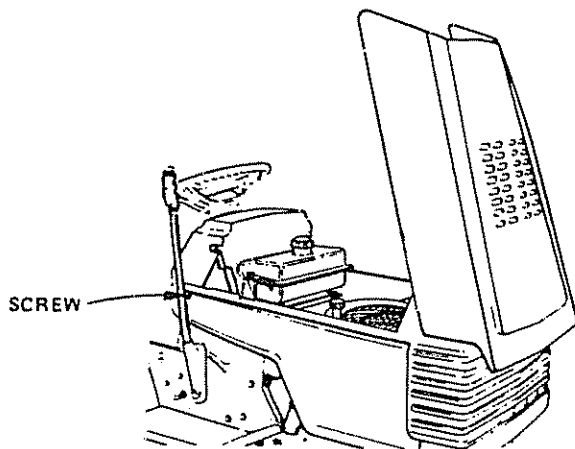

FIGURE 23

## 16. Fuse Replacement

Replace with 30 amp automotive - type plug-in fuse.

## 17. Hood Removal

- To raise hood, lift at rear of hood.
- To remove hood, grill and side panels, raise hood and loosen one screw on each side panel. (This screw remains in the side panel) (Fig. 23).
- Unsnap headlight connection (Fig. 24).
- Stand in front of tractor. Grasp hood and tilt forward and lift off (Fig. 24).
- To reinstall, reverse above procedure.

## 18. Mower Removal

- Remove mower belt per instructions under "Mower Drive Belt Removal" through step(c).
- Pull retainer springs out of rear suspension trunnions. Remove rear suspension trunnions from lift brackets (Fig. 25).
- Pull retainer spring out of rear hinge pin. Remove rear hinge pin. (Fig. 25)
- Pull retainer spring out of front hinge pin. Remove front hinge pin (Fig.25).
- Use lift lever to raise suspension arms. Slide mower out from under tractor.

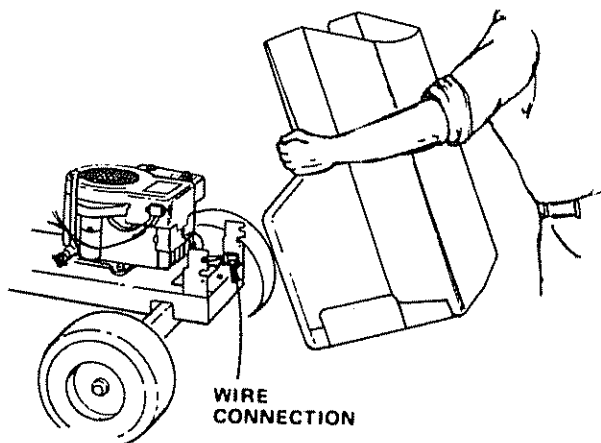

FIGURE 24

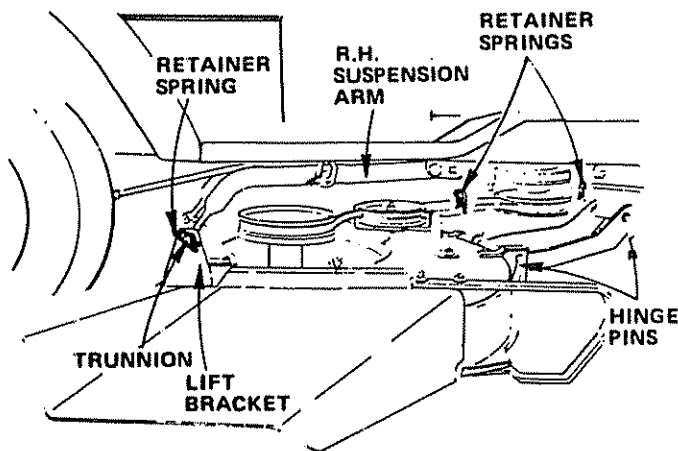

FIGURE 25

**NOTE: IF AN ATTACHMENT OTHER THAN THE MOWER DECK IS TO BE MOUNTED ON THE TRACTOR, THE L.H. AND R.H. SUSPENSION ARMS (FIG. 25) SHOULD BE REMOVED FROM TRACTOR.**

# REPAIR AND ADJUSTMENT

## 19. Mower Installation

Your Mower installs without the use of tools. Raise Attachment Lift Lever to its highest position. Turn height adjustment knob to lowest position.

- a. Slide Mower under tractor, discharge guard to R.H. Side.
- b. Install front hinge pin through axle and parallel link (Fig.26). Secure with retainer spring.
- c. Install rear hinge pin through mower lift brackets and parallel link (Fig.26). Secure with retainer spring.
- d. Move lift lever forward to lower suspension arms.
- e. Slide trunnions through lift brackets holes and secure with retainer spring (Fig.27).
- f. With belt routed around R.H. mower pulley and idler pulley, roll belt over mower drive pulley (Fig.27). Drive schematic decal on mower housing.
- g. Roll belt over L.H. mower pulley.
- h. Use lift lever to raise mower.
- i. Turn height adjustment knob clockwise (↻) to the middle of its travel.

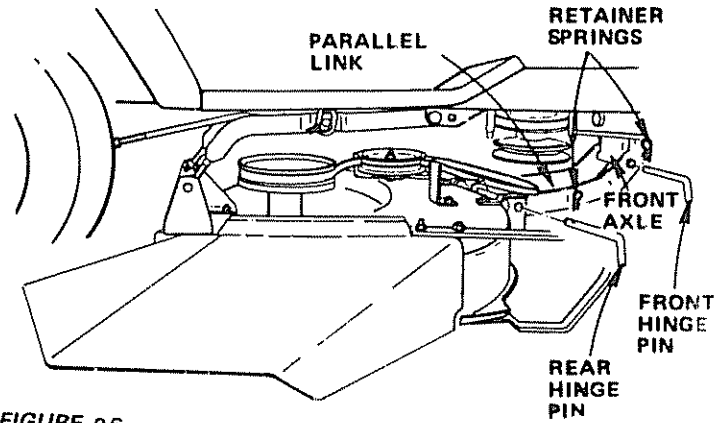

FIGURE 26

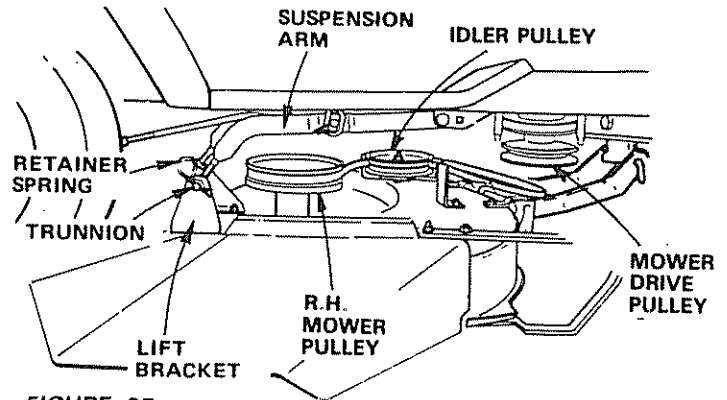

FIGURE 27

# REPAIR AND ADJUSTMENT

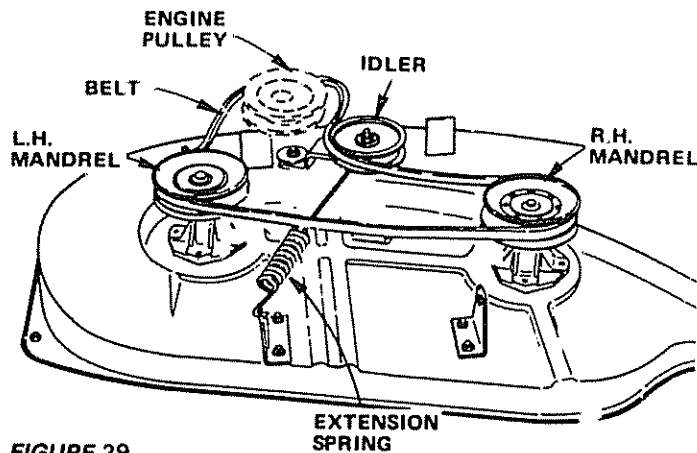

FIGURE 29

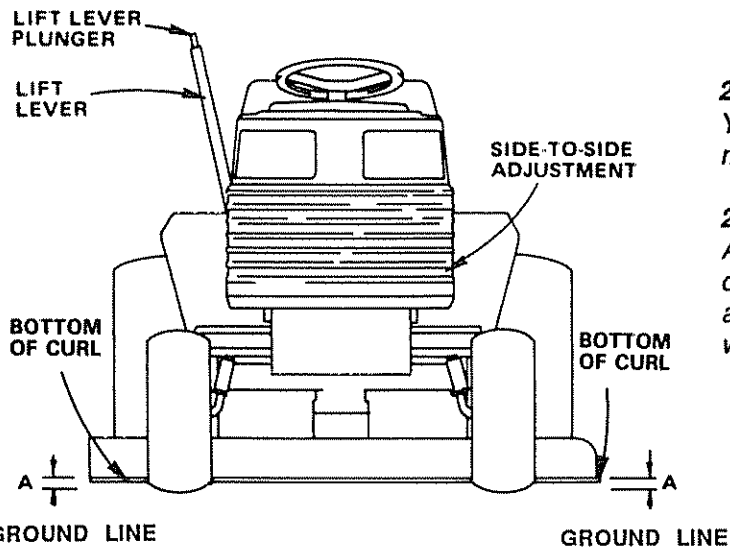

FIGURE 30

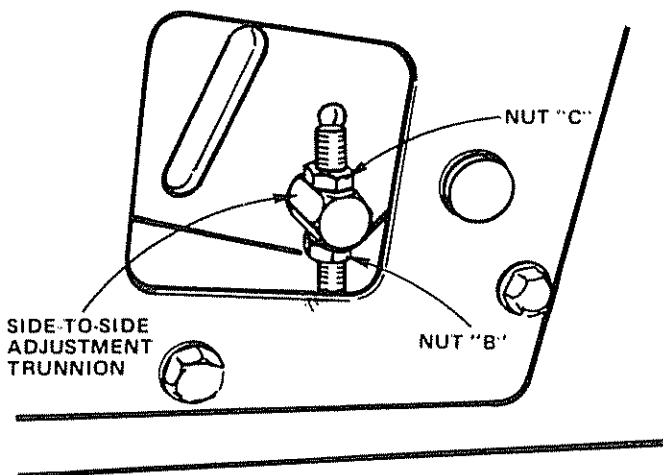

FIGURE 31

## 20. Mower Drive Belt Replacement

REPLACE ONLY WITH BELTS SPECIFIED IN THIS MANUAL.

- Place attachment clutch switch in "disengaged" position.
- Turn height adjustment knob counterclockwise (↺) to lowest position.
- Move attachment lift lever (Fig.28) forward to low mower to its lowest position.
- Roll belt off mower drive pulley (Fig.29).
- Remove belt from mower pulleys and idler pulk (Fig.29).
- To install mower drive belt, reverse above procedur. Make sure drive belt is engaged in all pulleys.

## 21. Mower Drive Belt Adjustment

Your tractor has a self tensioning belt system and no adjustment is necessary.

## 22. Level Mower Housing

Adjust the mower while tractor is parked on level ground or driveway. Make sure tire pressures are 14 PSI in front tires and 12 PSI in rear tires. If tires are over or under inflated, you will not properly adjust your mower.

### Side-to-Side Mower Adjustment

- Depress lift lever plunger and use lift lever to raise mower to maximum cutting height. (Fig. 30).
- Measure height from bottom of curl to ground line at front of mower. Distance "A" should be the same on both sides (Fig. 30).
- If distance "A" needs to be changed, snap out access hole cover on L.H. side above footrest. Use 9/16" wrench on nuts "B" and "C" at side-to-side adjustment trunnion (Fig. 31).
- To raise left side of mower, loosen nut "B" and tighten nut "C".
- To lower left side of mower, loosen nut "C" and tighten nut "B".

NOTE: ONE ROTATION OF ADJUSTMENT NUTS IS EQUIVALENT TO APPROXIMATELY 3/16" HEIGHT CHANGE.

- Be sure all nuts are securely tightened.

# REPAIR AND ADJUSTMENT

## Front-To-Rear Mower Adjustment

- To obtain the best cutting results, your mower housing should be adjusted so the front and rear flange distance "D" (Fig. 32) is 1/2" lower in front when the mower is positioned in the highest cutting position. NOTE: MEASURE DISTANCE "D" FROM GROUND LINE TO BOTTOM OF CURL ON RIGHT REAR FLANGE AND COMPARE TO DISTANCE "D" AT BOTTOM OF CURL ON RIGHT FRONT FLANGE.
- To raise rear of mower, loosen nut "E" on both rear suspension arms (Fig. 33). Screw both nuts "F" up EQUAL NUMBER OF TURNS (Fig. 33).
- When distance "D" is 1/2" lower at front than rear tighten nuts "E".
- To lower rear of mower, loosen nut "F" on both rear suspension arms an EQUAL NUMBER OF TURNS (Fig. 33).
- When distance "D" is 1/2" lower at front than rear, retighten nuts "E".

NOTE: WHEN ADJUSTING REAR SUSPENSION TRUNNIONS, ALWAYS ADJUST BOTH EQUALLY SO MOWER WILL STAY LEVEL.

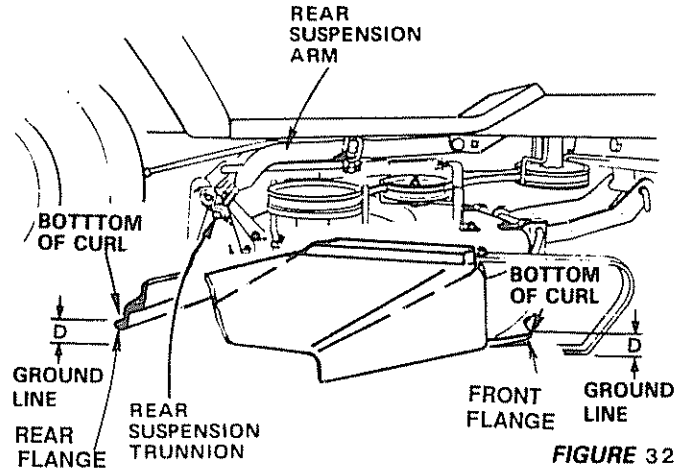

FIGURE 32

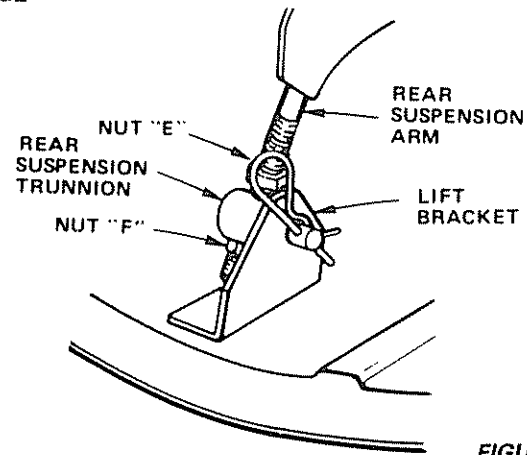

FIGURE 33

## 23. Storage

Remove mower from tractor for winter storage. When mower is to be stored for a period of time, clean it thoroughly, remove all dirt, grease, leaves, etc. Give blades and underside of housing a good coat of grease or rust preventative. Store in a clean dry area.

### A. Fuel System

NOTE: GASOLINE STORAGE STABILIZER (SUCH AS STA-BIL) MUST BE ADDED TO GASOLINE WHEN STORING UNIT. SUCH AN ADDITIVE WILL MINIMIZE FUEL GUM DEPOSITS PREVENTING A CLOGGED FUEL SYSTEM.

Run engine 10 minutes after adding STA-BIL to gasoline to allow additive to reach carburetor.

### B. Engine Oil

Drain (with engine warm) and replace with clean engine oil, (See chart page 16).

### C. Cylinder

- Remove spark plug
- Pour one ounce of oil through spark plug hole into cylinder
- Turn ignition key to "START" position for a few seconds to distribute oil.
- Replace with new spark plug

### D. Battery

- Prior to storage, clean terminals and top of battery.
- After a period of time in storage, battery may require recharging.

### E. General Cleaning

Clean engine, battery, seat, finish, etc., of all foreign matter.

### F. Store in a Clean Dry Area

# TROUBLESHOOTING

PROBLEM	CAUSE/REMEDY (SEE INDEX)
WILL NOT START	<p>Push Clutch/Brake Pedal into Brake Position.            Move Attachment Clutch Switch to "Disengaged" Position            Fill Fuel Tank with Gasoline. Check Fuel Line and Carburetor            (clean if necessary) Replace Fuel Filter            Check fuse for fault and replace            Recharge or replace Battery            Check Wiring            Replace Spark Plug and adjust gap</p>
WILL NOT TURN OVER	<p>Charge Battery            Replace Ignition Switch            Depress Clutch/Brake Pedal            Disengage Attachment Clutch Switch            Replace Interlock Switch            Replace Solenoid            Replace Fuse            Check All Wire Connections</p>
ENGINE CLICKS BUT WON'T START	<p>Replace Starter            Charge or Replace Battery</p>
HARD TO START	<p>Place Throttle Control in "FAST" position            and run starter several times to clear out gas            Remove and clean Fuel Tank and lines. Replace Fuel Filter            Remove Air Filter and clean            Replace Spark Plug and adjust gap            Replace Battery            Check the wiring and Spark Plug            Drain Fuel Tank and Carburetor, use fresh fuel            Make necessary adjustments to Carburetor            Major Engine Overhaul</p>
ENGINE MISSES OR LACKS POWER	<p>Shift to a lower gear or reduce load            Remove and clean Fuel Tank; replace Fuel Filter            Remove and clean Air Cleaner            Make necessary carburetor adjustments            Clean Air Screen            Add or change oil            Replace Spark Plug            Check Spark Plug and check for loose wires            Major Engine overhaul</p>
ENGINE OVERHEATS	<p>Clean Air Screen            Add or change oil            Clean Engine Cooling Fins            Remove and clean Muffler or replace            Remove and clean Air Filter            Use fresh fuel and adjust Carburetor</p>
NO LIGHTS	<p>Check Fuse, Switch and wire connections. Replace            Headlight Bulbs</p>
WON'T CHARGE	<p>Check Fuse and replace            Replace Battery            Replace Regulator            Replace Alternator</p>
<p><b>OPERATOR PRESENCE SYSTEM WILL NOT SHUT DOWN            WHEN OPERATOR LEAVES SEAT.</b>  <i>Note: This tractor is equipped with an operator presence sens-            ing system. Any attempt by the operator to leave the seat with            the engine running and the attachment clutch engaged will shut            down the engine.</i></p>	<p>Engage attachment clutch            Check all wire connections            Check seat switch Check operator presence relay.            Check PTO Switch.</p>



# TROUBLESHOOTING

<p><b>UNSATISFACTORY MOWER PERFORMANCE UNEVEN DISTRIBUTION OF CLIPPINGS</b></p>	<p><i>Check air pressure in tires Check front to rear and side to side mower adjustment Use a slower ground speed Check engines RPM's (refer to Carburetor Adjustment) Replace mower blades Reinstall mower blades with top of blade up Replace with proper mower blades Re-adjust mower drive belt</i></p>
<p><b>MOWER BLADES WILL NOT ROTATE</b></p>	<p><i>Install new Mower Drive Belt Reinstall Mower Drive Belt Adjust Mower Drive Belt Replace Frozen Mandrel Replace Frozen Idler Pulley</i></p>
<p><b>EXCESSIVE MOWER VIBRATION</b></p>	<p><i>Replace Bent or Unbalanced Blades Replace Mandrel, Straighten Deck or replace</i></p>
<p><b>WIND ROWING STRIPPING OR DROPPING OF GRASS CLIPPINGS</b></p>	<p><i>Let grass dry out Clean underside of Mower Deck Readjust Mower</i></p>
<p><b>UNEVEN CUT OR SCALPING</b></p>	<p><i>Readjust Mower</i></p>

# SERVICE NOTES