

**SEARS**

# CRAFTSMAN®

**MODEL NUMBER 917.259544 OWNER'S MANUAL**

- **Assembly**
- **Operation**
- **Customer Responsibilities**
- **Service and Adjustments**
- **Repair Parts**

**EZ<sup>3</sup>**

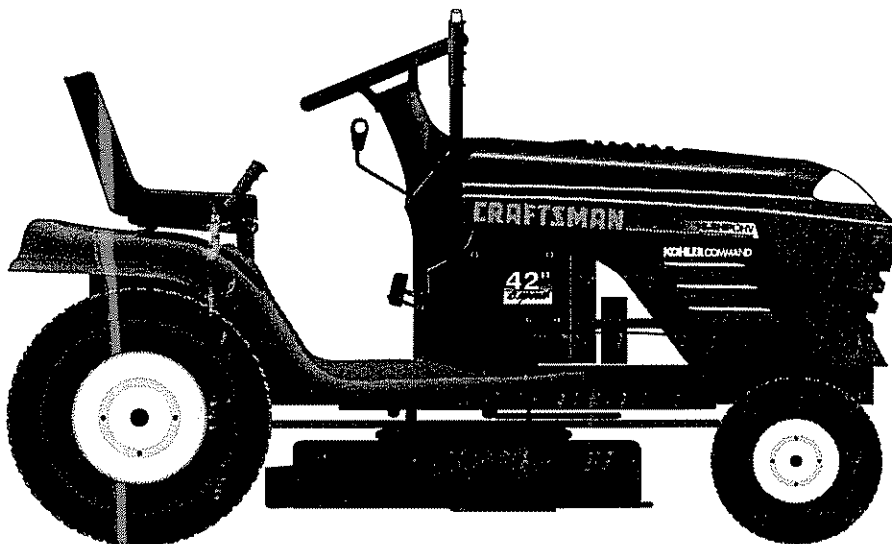

**This product has a low emission engine which operates differently from previously built engines. Before you start the engine, read and understand this Owner's Manual.**

For answers to your questions about this product, Call:

**1-800-659-5917**  
Sears Craftsman Help Line  
5 am - 5 pm, Mon - Sat

**CAUTION: Read and follow all safety rules and instructions before operating this equipment.**  
FOR CONSUMER ASSISTANCE HOT LINE, CALL THIS TOLL FREE NUMBER: 1-800-659-5917

Sears, Roebuck and Co., Hoffman Estates, IL 60179 U.S.A.



# SAFETY RULES



## Safe Operation Practices for Ride-On Mowers

**IMPORTANT:** THIS CUTTING MACHINE IS CAPABLE OF AMPUTATING HANDS AND FEET AND THROWING OBJECTS. FAILURE TO OBSERVE THE FOLLOWING SAFETY INSTRUCTIONS COULD RESULT IN SERIOUS INJURY OR DEATH.

### I. GENERAL OPERATION

- Read, understand, and follow all instructions in the manual and on the machine before starting.
- Only allow responsible adults, who are familiar with the instructions, to operate the machine.
- Clear the area of objects such as rocks, toys, wire, etc., which could be picked up and thrown by the blade.
- Be sure the area is clear of other people before mowing. Stop machine if anyone enters the area.
- Never carry passengers.
- Do not mow in reverse unless absolutely necessary. Always look down and behind before and while backing.
- Be aware of the mower discharge direction and do not point it at anyone. Do not operate the mower without either the entire grass catcher or the guard in place.
- Slow down before turning.
- Never leave a running machine unattended. Always turn off blades, set parking brake, stop engine, and remove keys before dismounting.
- Turn off blades when not mowing.
- Stop engine before removing grass catcher or unclogging chute.
- Mow only in daylight or good artificial light.
- Do not operate the machine while under the influence of alcohol or drugs.
- Watch for traffic when operating near or crossing roadways.
- Use extra care when loading or unloading the machine into a trailer or truck.

### II. SLOPE OPERATION

Slopes are a major factor related to loss-of-control and tipover accidents, which can result in severe injury or death. All slopes require extra caution. If you cannot back up the slope or if you feel uneasy on it, do not mow it.

#### DO:

- Mow up and down slopes, not across.
- Remove obstacles such as rocks, tree limbs, etc.
- Watch for holes, ruts, or bumps. Uneven terrain could overturn the machine. *Tall grass can hide obstacles.*
- Use slow speed. Choose a low gear so that you will not have to stop or shift while on the slope.
- Follow the manufacturer's recommendations for wheel weights or counterweights to improve stability.
- Use extra care with grass catchers or other attachments. These can change the stability of the machine.
- Keep all movement on the slopes *slow* and *gradual*. Do not make sudden changes in speed or direction.
- Avoid starting or stopping on a slope. If tires lose traction, disengage the blades and proceed slowly *straight* down the slope.

#### DO NOT:

- *Do not* turn on slopes unless necessary, and then, turn slowly and gradually downhill, if possible.
- *Do not* mow near drop-offs, ditches, or embankments. The mower could suddenly turn over if a wheel is over the edge of a cliff or ditch, or if an edge caves in.
- *Do not* mow on wet grass. Reduced traction could cause sliding.
- *Do not* try to stabilize the machine by putting your foot on the ground.
- *Do not* use grass catcher on steep slopes.

### III. CHILDREN

Tragic accidents can occur if the operator is not alert to the presence of children. Children are often attracted to the machine and the mowing activity. *Never* assume that children will remain where you last saw them.

- Keep children out of the mowing area and under the watchful care of another responsible adult.
- Be alert and turn machine off if children enter the area.
- Before and when backing, look behind and *down* for small children.
- Never carry children. They may fall off and be seriously injured or interfere with safe machine operation.
- Never allow children to operate the machine.
- Use extra care when approaching blind corners, shrubs, trees, or other objects that may obscure vision.

### IV. SERVICE

- Use extra care in handling gasoline and other fuels. They are flammable and vapors are explosive.
  - Use only an approved container.
  - Never remove gas cap or add fuel with the engine running. Allow engine to cool before refueling. Do not smoke.
  - Never refuel the machine indoors.
  - Never store the machine or fuel container inside where there is an open flame, such as a water heater.
- Never run a machine inside a closed area.
- Keep nuts and bolts, especially blade attachment bolts, tight and keep equipment in good condition.
- Never tamper with safety devices. Check their proper operation regularly.
- Keep machine free of grass, leaves, or other debris build-up. Clean oil or fuel spillage. Allow machine to cool before storing.
- Stop and inspect the equipment if you strike an object. Repair, if necessary, before restarting.
- Never make adjustments or repairs with the engine running.
- Grass catcher components are subject to wear, damage, and deterioration, which could expose moving parts or allow objects to be thrown. Frequently check components and replace with manufacturer's recommended parts, when necessary.
- Mower blades are sharp and can cut. Wrap the blade(s) or wear gloves, and use extra caution when servicing them.
- Check brake operation frequently. Adjust and service as required.



**Look for this symbol to point out important safety precautions. It means CAUTION!!! BECOME ALERT!!! YOUR SAFETY IS INVOLVED.**



**CAUTION: Always disconnect spark plug wire and place wire where it cannot contact spark plug in order to prevent accidental starting when setting up, transporting, adjusting or making repairs.**



## WARNING

**The engine exhaust from this product contains chemicals known to the State of California to cause cancer, birth defects, or other reproductive harm.**

**CONGRATULATIONS** on your purchase of a Sears Tractor. It has been designed, engineered and manufactured to give you the best possible dependability and performance.

Should you experience any problem you cannot easily remedy, please contact your nearest Sears Authorized Service Center/Department. We have competent, well-trained technicians and the proper tools to service or repair this tractor.

Please read and retain this manual. The instructions will enable you to assemble and maintain your tractor properly. Always observe the "SAFETY RULES".

MODEL NUMBER	917.259544
SERIAL NUMBER	_____
DATE OF PURCHASE	_____
THE MODEL AND SERIAL NUMBERS WILL BE FOUND ON A PLATE UNDER THE SEAT.	
YOU SHOULD RECORD BOTH SERIAL NUMBER AND DATE OF PURCHASE AND KEEP IN A SAFE PLACE FOR FUTURE REFERENCE.	

## MAINTENANCE AGREEMENT

A Sears Maintenance Agreement is available on this product. Contact your nearest Sears store for details.

## CUSTOMER RESPONSIBILITIES

- Read and observe the safety rules.
- Follow a regular schedule in maintaining, caring for and using your tractor.
- Follow the instructions under "Customer Responsibilities" and "Storage" sections of this owner's manual.

## PRODUCT SPECIFICATIONS

HORSEPOWER:	15.5
GASOLINE CAPACITY AND TYPE:	1.25 GALLONS ' UNLEADED REGULAR
OIL TYPE (API-SF/SG/SH):	SAE 10W30 (above 32°F) SAE 5W-30 (below 32°F)
OIL CAPACITY:	W/ FILTER: 4.0 PINTS W/O FILTER: 3.5 PINTS
SPARK PLUG: (GAP: .040")	CHAMPION RC12YC
VALVE CLEARANCE:	NOT ADJUSTABLE
GROUND SPEED (MPH):	FORWARD: 1st 1.1 2nd 1.5 3rd 2.3 4th 3.5 5th 4.4 6th 5.7 REVERSE: 1.7
TIRE PRESSURE:	FRONT: 14 PSI REAR: 10 PSI
CHARGING SYSTEM:	3 AMPS BATTERY 5 AMPS HEADLIGHTS
BATTERY:	AMP/HR: 30 MIN. CCA: 240 CASE SIZE: U1R
BLADE BOLT TORQUE:	30-35 FT. LBS.

**WARNING:** This tractor is equipped with an internal combustion engine and should not be used on or near any unimproved forest-covered, brush-covered or grass-covered land unless the engine's exhaust system is equipped with a spark arrester meeting applicable local or state laws (if any). If a spark arrester is used, it should be maintained in effective working order by the operator.

In the state of California the above is required by law (Section 4442 of the California Public Resources Code). Other states may have similar laws. Federal laws apply on federal lands. A spark arrester for the muffler is available through your nearest Sears Authorized Service Center/Department (See REPAIR PARTS section of this manual).

## LIMITED TWO YEAR WARRANTY ON CRAFTSMAN RIDING EQUIPMENT

For two (2) years from the date of purchase, if this Craftsman Riding Equipment is maintained, lubricated and tuned up according to the instructions in the owner's manual, Sears will repair or replace, free of charge, any parts found to be defective in material or workmanship.

This Warranty does not cover:

- Expendable items which become worn during normal use, such as blades, spark plugs, air cleaners, belts, etc.
- Tire replacement or repair caused by punctures from outside objects, such as nails, thorns, stumps, or glass.
- Repairs necessary because of operator abuse, negligence, improper storage or accident or the failure to maintain the equipment according to the instructions contained in the owner's manual.
- Riding equipment used for commercial or rental purposes.

## LIMITED 90 DAY WARRANTY ON BATTERY

For ninety (90) days from date of purchase, if any battery included with this riding equipment proves defective in material or workmanship and our testing determines the battery will not hold a charge, Sears will replace the battery at no charge.

IN-HOME WARRANTY SERVICE ON YOUR CRAFTSMAN RIDING EQUIPMENT IS AVAILABLE AT NO-CHARGE FOR 30 DAYS FROM THE DATE OF PURCHASE. PLEASE CONTACT YOUR NEAREST SERVICE CENTER. AFTER 30 DAYS FROM THE DATE OF PURCHASE, WARRANTY SERVICE IS AVAILABLE BY TAKING YOUR CRAFTSMAN RIDING EQUIPMENT TO YOUR NEAREST SEARS SERVICE CENTER. (IN-HOME WARRANTY SERVICE WILL STILL BE AVAILABLE AFTER 30 DAYS FROM THE DATE OF PURCHASE BUT A STANDARD TRIP CHARGE WILL APPLY.) THIS WARRANTY APPLIES ONLY WHILE THIS PRODUCT IS IN THE UNITED STATES.

This Warranty gives you specific legal rights, and you may also have other rights which may vary from state to state.

SEARS, ROEBUCK AND CO., D/817 WA, HOFFMAN ESTATES, IL 60179

# TABLE OF CONTENTS

SAFETY RULES .....	2	MAINTENANCE SCHEDULE .....	15
PRODUCT SPECIFICATIONS .....	3	SERVICE AND ADJUSTMENTS .....	20-25
CUSTOMER RESPONSIBILITIES .....	3, 15-19	STORAGE .....	26
WARRANTY .....	3	TROUBLESHOOTING .....	27-28
TABLE OF CONTENTS .....	4	REPAIR PARTS - TRACTOR .....	30-47
ASSEMBLY .....	7-9	REPAIR PARTS - ENGINE .....	48-53
OPERATION .....	10-14	PARTS ORDERING/SERVICE .....	BACK PAGE





## INDEX

<b>A</b>		Engine:	Operation .....	10-14
Accessories .....	5	Air Filter .....	Operating Mower .....	13
Adjustments:		Air Screen .....	Options:	
Brake .....	22	Cooling Fins, Engine .....	Accessories .....	5
Carburetor .....	25	Oil Change .....	Spark Arrester .....	3,40
Mower:		Oil Level .....		
Front-To-Back .....	21	Oil Type .....	<b>P</b>	
Side-To-Side .....	21	Preparation .....	Parking Brake .....	11-12
Throttle Control Cable .....	25	Repair Parts .....	Parts Bag .....	6
Air Filter, Engine .....	18	Starting .....	Parts, Replacement/Repair .....	30-47
Air Screen, Engine .....	18	Storage .....	Product Specifications .....	3
Assembly .....	7-9		<b>R</b>	
<b>B</b>		<b>F</b>	Repair Parts .....	30-47
Battery:		Filters:	<b>S</b>	
Charging .....	7	Air .....	Safety Rules .....	2
Cleaning .....	16	Fuel .....	Seat .....	8
Starting with Weak Battery .....	23	Fuel:	Service and Adjustments .....	20-25
Storage .....	26	Type .....	Brake .....	22
Terminals .....	16	Storage .....	Carburetor .....	25
Belts:		Fuse .....	Fuse .....	24
Motion Drive		<b>G</b>	Hood Removal/Installation .....	24
Removal/Replacement .....	22	Gauge Wheels .....	Motion Drive Belt	
Mower Blade Drive		<b>H</b>	Removal/Replacement .....	22
Removal/Replacement .....	22	Hood Removal/Installation .....	Mower Blade Drive Belt	
Blade:		<b>L</b>	Removal/Replacement .....	22
Sharpening .....	16	Leveling Mower Deck .....	Mower Adjustment:	
Replacement .....	16	Lubrication Chart .....	Front-to-Back .....	21
Brake Adjustment .....	22	<b>M</b>	Side-to-Side .....	21
<b>C</b>		Maintenance Schedule .....	Mower Installation .....	20
Carburetor Adjustment .....	25	Mower:	Mower Removal .....	20
Controls, Tractor .....	11	Adjustment, Front-to-Back .....	Tire Care .....	9,16,23
Customer Responsibilities .....	15-19	Adjustment, Side-to-Side .....	Slope Guide Sheet .....	55
Engine:		Blade Sharpening .....	Spark Plugs .....	18
Air Filter .....	18	Blade Replacement .....	Specifications .....	3
Air Screen, Engine .....	18	Cutting Height .....	Starting the Engine .....	13-14
Battery .....	17	Installation .....	Steering Wheel .....	7,23
Cooling Fins, Engine .....	18	Operation .....	Stopping the Tractor .....	12
Engine Oil .....	17	Removal .....	Storage .....	26
Fuel Filter .....	19	Mowing Tips .....	<b>T</b>	
Spark Plugs .....	18	Muffler .....	Throttle Control Cable Adjustment .....	25
Tractor:		Spark Arrester .....	Tires .....	9,16,23
Blades .....	16	Mulcher Plate .....	Trouble Shooting Chart .....	27-28
Lubrication Chart .....	15	<b>O</b>	Transaxle Repair Parts .....	46-47
Maintenance Schedule .....	15	Oil:	<b>W</b>	
Tire Care .....	9,16,23	Cold Weather Conditions .....	Warranty .....	3
Cutting Height, Mower .....	12	Engine .....	Wiring Diagram .....	30
<b>E</b>		Storage .....	Wiring Schematic .....	29
Electrical:				
Interlocks and Relays .....	24			
Schematic .....	29			
Wiring Diagram .....	30			

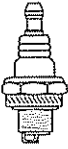

# ACCESSORIES AND ATTACHMENTS

These accessories and attachments were available through most Sears retail outlets and service centers when the tractor was purchased. Most Sears stores can order these items for you when you provide the model number of your tractor.

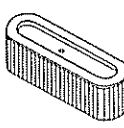
## ENGINE

SPARK PLUG	GAS CAN	ENGINE OIL	FUEL STABILIZER	AIR FILTER
				

## MAINTENANCE

BLADES	BELTS
	

## PERFORMANCE

Sears offers a wide variety of attachments that fit your tractor. Many of these are listed below with brief explanations of how they can help you. This list was current at the time of publication; however, it may change in future years - more attachments may be added, changes may be made in these attachments, or some may no longer be available or fit your model. **Contact your nearest Sears store for the accessories and attachments that are available for your tractor.**

Most of these attachments do not require additional hitches or conversion kits (those that do are indicated) and are designed for easy attaching and detaching.

**AERATOR** promotes deep root growth for a healthy lawn. Tapered 2.5-inch steel spikes mounted on 10-inch diameter discs puncture holes in soil at close intervals to let moisture soak in. Steel weight tray for increased penetration.

**BAGGER** lets you collect grass clippings and leaves for a healthier, neater looking lawn. Two Permanex containers hold 30-gallon plastic bags.

**BUMPER** protects front end of tractor from damage.

**CARTS** make hauling easy. Variety of sizes available, plus accessories such as side panel kits, tool caddy, cart cover, protective mat and dolly.

**CORING AERATOR** takes small plugs out of soil to allow moisture and nutrients to reach grass roots. 36-inch swath. 24 hardened steel coring tips. 150 lb. capacity weight tray.

**EASY OIL DRAIN VALVE** makes oil changes easier, faster.

**FRONT NOSE ROLLER** canters in front of mower deck to reduce chances of "scalping" on uneven terrain.

**GANG HITCH** lets you tow 2 or 3 pull-behind attachments at once, such as sweepers, dethatchers, aerators (not for use with rollers, carts or other heavy attachments).

**GAUGE WHEELS** on both sides of the mower deck reduce chances of "scalping" on uneven terrain. For mower decks not so equipped.

**MULCH RAKE/DETHATCHER** loosens soil and flips thatch and matted leaves to lawn surface for easy pickup. Twenty spring tine teeth. Useful to prepare bare areas for seeding. Available for front or rear mounting. **HIGH PERFORMANCE REEL-ACTION SPRING TINE DETHATCHER** covers 36-inch wide path and tosses thatch into large hopper. Mounts behind tractor.

**MULCHING CLOSE-OUT PLATE KIT**, once installed, lets you mulch, discharge or bag clippings (bagger optional) without changing blades. For models not equipped as 3-in-1 Convertible mowers. See "MOWER" in the Repair Parts section of this manual.

**RAMP TOPS AND FEET** let you load and unload tractor from a pickup truck. Use with 2 x 8 or 2 x 10 lumber.

**ROLLER** for smoother lawn surface. 36-inch wide, 18-inch diameter water-tight drum holds up to 390 lbs. of weight. Rounded edges prevent harm to turf. Adjustable scraper automatically cleans drum.

**SNOW BLADE** for snow removal only. 14-inch high, 48-inch wide blade clears 42-inch path when angled left or right. Raises, lowers with side lever. Adjustable skids; replaceable, reversible scraper bar. (Use with tire chains and wheel weights and/or rear drawbar weight.)

**SNOWTHROWER** has 40-inch swath. Drum-type auger handles powdery and wet/heavy snow. Mounts easily with simple pin arrangement. Discharge chute adjusts from tractor seat. 6-inch diameter spout discharges snow 10 to 50 feet. Lift controlled at tractor seat. (Use with chains and wheel weights and/or rear drawbar weight.)

**SPRAYERS** use 12-volt DC electric motor that connects to the tractor battery or other 12-volt source. Includes booms for automatic spraying and hand held wand for spot spraying. Wand has adjustable spray pattern. For applying herbicides, insecticides, fungicides and liquid fertilizers.

**SPREADER/SEEDERS** make seeding, fertilizing, and weed killing easy. Broadcast spreaders are also useful for granular deicers and sand.

**SWEEPERS** let you collect grass clippings and leaves.

**TILLER** has 5 hp engine and 36-inch swath to prepare seed beds, cultivate and compost garden residue. Tiller has its own built-in lift and depth control system and does NOT require a sleeve hitch. Fits any lawn, yard or garden tractor. Simply hook up to the tractor drawbar and go! **Optional accessories** convert unit for dethatching, aerating, hilling... without tools.

**TIRE CHAINS** are heavy duty; closely spaced extra-large cross links give smooth ride, outstanding traction.

**TRACTOR CAB** has heavy duty vinyl fabric over tubular steel frame, ABS plastic top; clear plastic windshield offers 360 degree visibility. Hinged metal doors with catch. Keeps operator warm and dry. Remove vinyl sides and windshields for use as sun protector in summer. **Optional accessories include:** tinted/tempered solid safety glass windshield with hand operated wiper; 12-volt amber caution light for mounting on cab top.

**VACS** for powerful collection of heavy grass clippings and leaves. **Optional wand attachment** to pick up debris in hard-to-reach places. **VAC/CHIPPER** includes a chipper-shredder.

**WEIGHT BRACKET** for drawbar for snow removal applications. Uses (1) 55 lb. weight.

**WHEEL WEIGHTS** for rear wheels provide needed traction for snow removal or dozing heavy materials.

# CONTENTS OF HARDWARE PACK

## Parts Bag contents shown full size

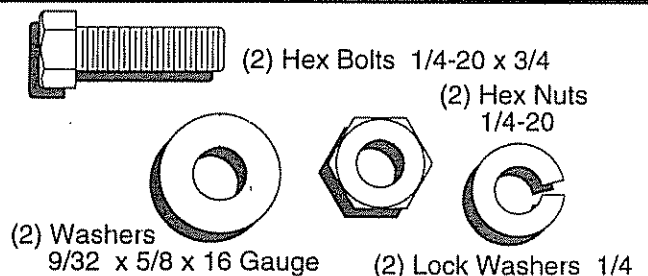
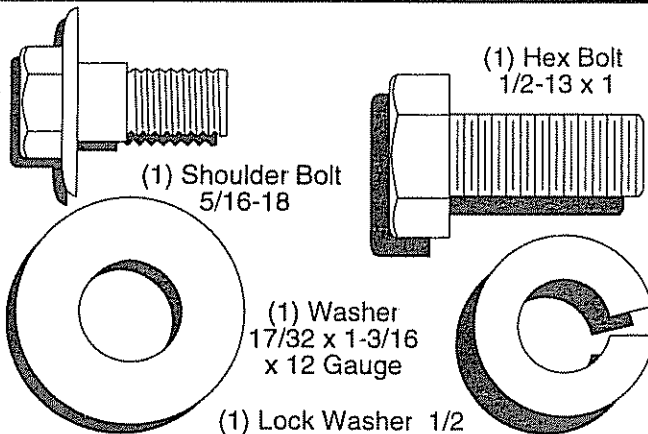
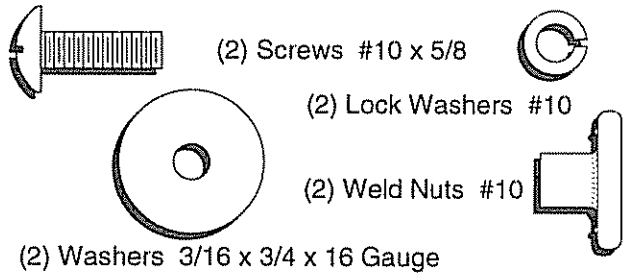
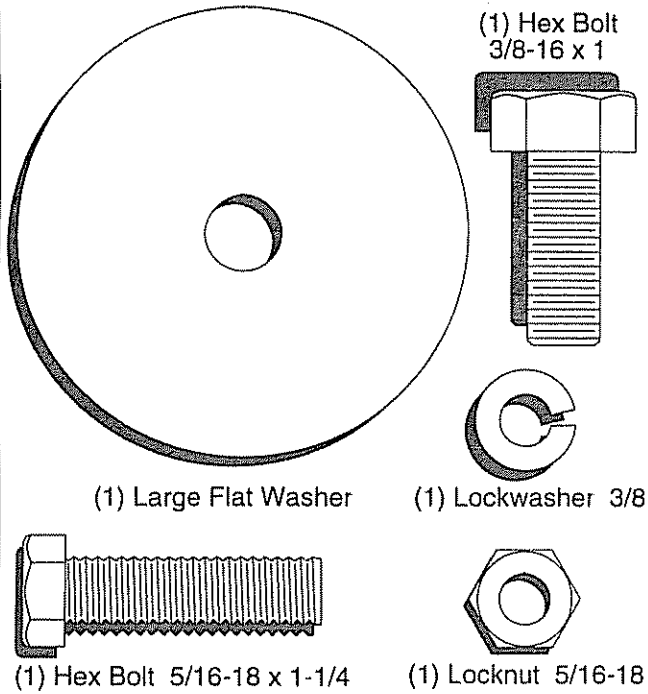

## Parts packed separately in carton

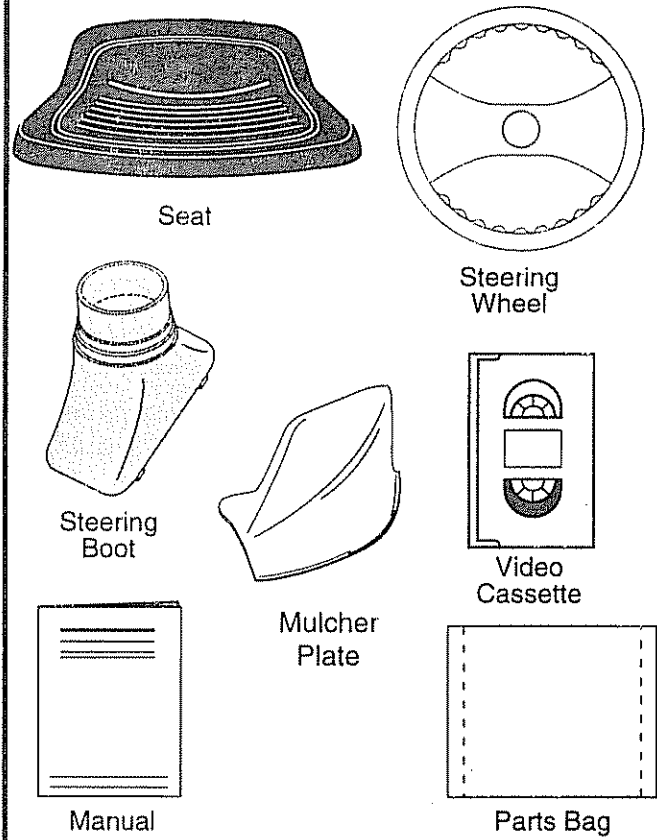

## Parts bag contents not shown full size

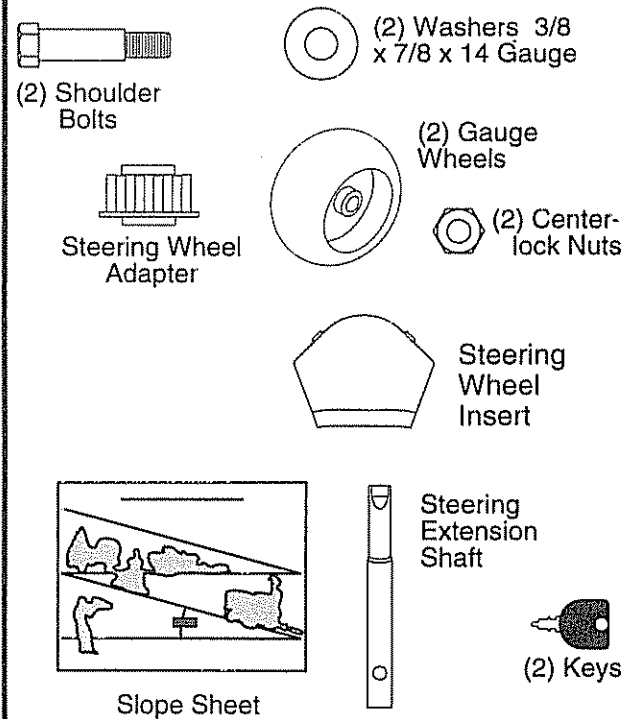

# ASSEMBLY

Your new tractor has been assembled at the factory with exception of those parts left unassembled for shipping purposes. To ensure safe and proper operation of your tractor all parts and hardware you assemble must be tightened securely. Use the correct tools as necessary to insure proper tightness.

## TOOLS REQUIRED FOR ASSEMBLY

A socket wrench set will make assembly easier. Standard wrench sizes are listed.

- |                                    |                      |
|------------------------------------|----------------------|
| (2) 7/16" wrenches                 | Tire pressure gauge  |
| (2) 1/2" wrenches                  | Phillips screwdriver |
| (1) 9/16" wrench                   | Utility knife        |
| (1) 3/4" socket with drive ratchet |                      |

When right or left hand is mentioned in this manual, it means when you are in the operating position (seated behind the steering wheel).

## TO REMOVE TRACTOR FROM CARTON

### UNPACK CARTON

- Remove all accessible loose parts and parts cartons from carton (See page 2).
- Cut, from top to bottom, along lines on all four corners of carton, and lay panels flat.
- Check for any additional loose parts or cartons and

### BEFORE ROLLING TRACTOR OFF SKID ATTACH STEERING WHEEL (See Fig. 1)

#### ASSEMBLE EXTENSION SHAFT AND BOOT

- Slide extension shaft onto lower steering shaft. Align mounting holes in extension and lower shafts and install 5/16 hex bolt and locknut. Tighten securely.

**IMPORTANT: TIGHTEN BOLT AND NUT SECURELY TO 18-22 FT. LBS TORQUE**

- Place tabs of steering boot over tab slots in dash and push down to secure.

#### INSTALL STEERING WHEEL

- Position front wheels of the tractor so they are pointing straight forward.
- Slide steering wheel adapter onto steering shaft extension.
- Position steering wheel so cross bars are horizontal (left to right) and slide inside boot and onto adapter.
- Assemble large flat washer, 3/8 lock washer, 3/8 hex bolt and tighten securely.
- Snap steering wheel insert into center of steering wheel.
- Remove protective materials from tractor hood and grill.

**IMPORTANT: CHECK FOR AND REMOVE ANY STAPLES IN SKID THAT MAY PUNCTURE TIRES WHERE TRACTOR IS TO ROLL OFF SKID.**

### TO ROLL TRACTOR OFF SKID (See Operation section for location and function of controls)

- Press lift lever plunger and raise attachment lift lever to its highest position.
- Release parking brake by depressing clutch/brake pedal.
- Place gearshift lever in neutral (N) position.
- Roll tractor backwards off skid.
- Remove banding holding discharge guard up against tractor.

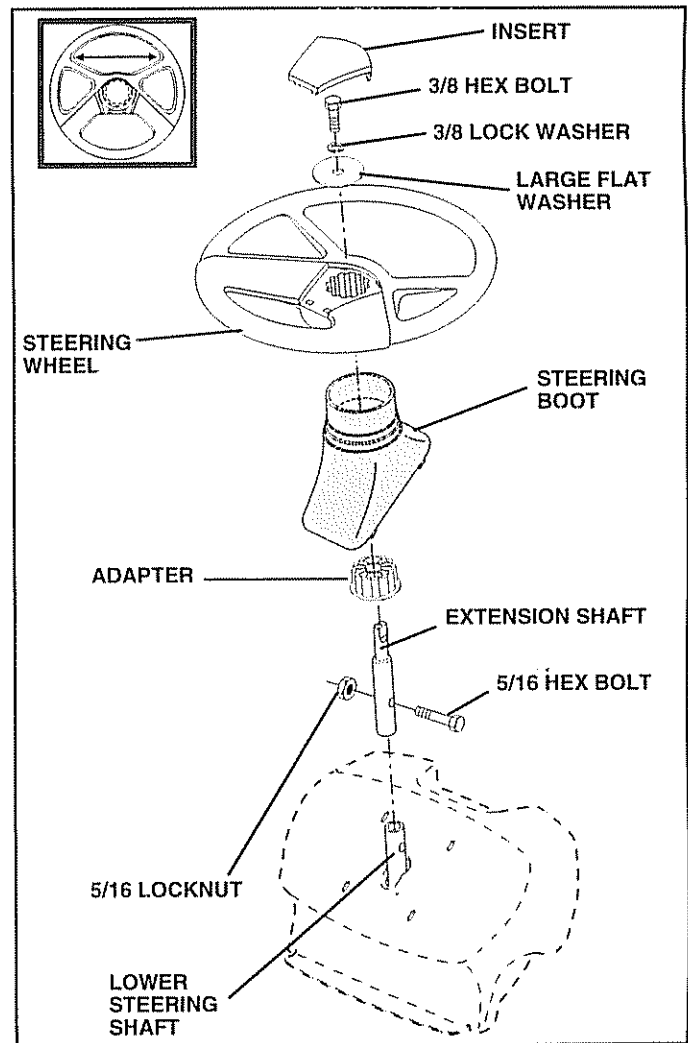

FIG. 1

## HOW TO SET UP YOUR TRACTOR

### CONNECT BATTERY (See Figs. 2 and 3)



**CAUTION: Do not short battery terminals by allowing a wrench or any other object to contact both terminals at the same time. Before connecting battery, remove metal bracelets, wristwatch bands, rings, etc.**

**Positive terminal must be connected first to prevent sparking from accidental grounding.**

- Remove cardboard packing from seat pan and lift seat pan to raised position.
- Open battery box door.
- Remove terminal protective caps and discard.
- If this battery is put into service after month and year indicated on label (label located between terminals) charge battery for minimum of one hour at 6-10 amps.
- First connect RED battery cable to positive (+) terminal with hex bolt, flat washer, lock washer and hex nut as shown. Tighten securely.



# ASSEMBLY

- Connect BLACK grounding cable to negative (-) terminal with remaining hex bolt, flat washer, lock washer and hex nut. Tighten securely.
- Close battery box door.

Open battery box door for:

- Inspection for secure connections (to tighten hardware).
- Inspection for corrosion.
- Testing battery.
- Jumping (if required).
- Periodic charging.

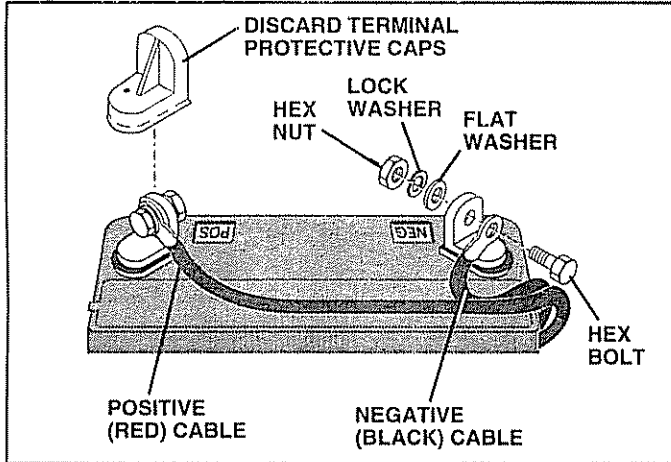

FIG. 2

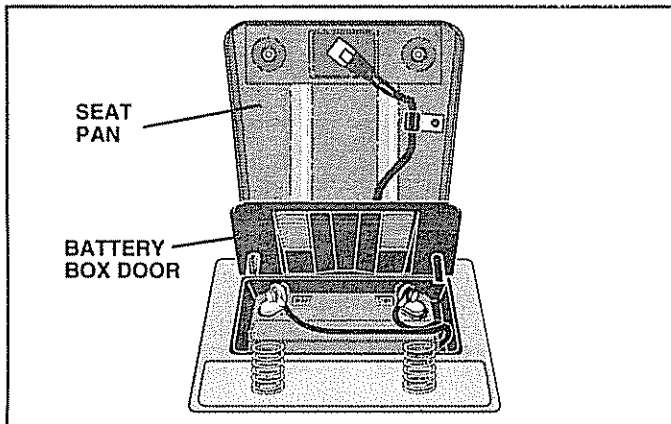

FIG. 3

## INSTALL SEAT (See Fig. 4)

Adjust seat before tightening adjustment bolt.

- Remove cardboard packing on seat pan.
- Place seat on seat pan and assemble shoulder bolt. Tighten shoulder bolt securely.
- Assemble adjustment bolt, lock washer and flat washer loosely. Do not tighten.
- Lower seat into operating position and sit on seat.
- Slide seat until a comfortable position is reached which allows you to press clutch/brake pedal all the way down.
- Get off seat without moving its adjusted position.
- Raise seat and tighten adjustment bolt securely.

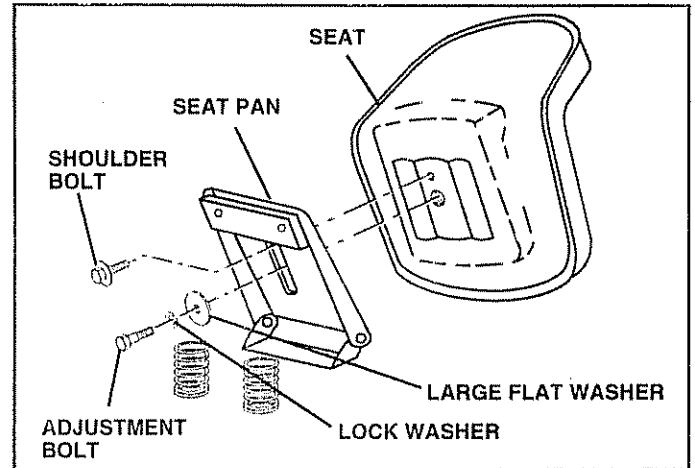

FIG. 4

## CHECK TIRE PRESSURE

The tires on your tractor were overinflated at the factory for shipping purposes. Correct tire pressure is important for best cutting performance.

- Reduce tire pressure to PSI shown in "PRODUCT SPECIFICATIONS" on page 3 of this manual.

## CHECK DECK LEVELNESS

For best cutting results, mower housing should be properly leveled. See "TO LEVEL MOWER HOUSING" in the Service and Adjustments section of this manual.

## CHECK FOR PROPER POSITION OF ALL BELTS

See the figures that are shown for replacing motion and mower blade drive belts in the Service and Adjustments section of this manual. Verify that the belts are routed correctly.

## CHECK BRAKE SYSTEM

After you learn how to operate your tractor, check to see that the brake is properly adjusted. See "TO ADJUST BRAKE" in the Service and Adjustments section of this manual.

## ASSEMBLE GAUGE WHEELS TO MOWER DECK (See Fig. 5A)

The gauge wheels are designed to keep the mower deck in proper position when operating mower. Be sure they are properly adjusted to ensure optimum mower performance.

- Assemble gauge wheels with tractor on a flat level surface.
- Adjust mower to desired cutting height (See "TO ADJUST MOWER CUTTING HEIGHT" in the Operation section of this manual).
- With mower in desired height of cut position, gauge wheels should be assembled so they are slightly off the ground. Install gauge wheel in appropriate hole with shoulder bolt, 3/8 washer, and 3/8-16 locknut and tighten securely.
- Repeat for opposite side installing gauge wheel in same adjustment hole.



# ASSEMBLY

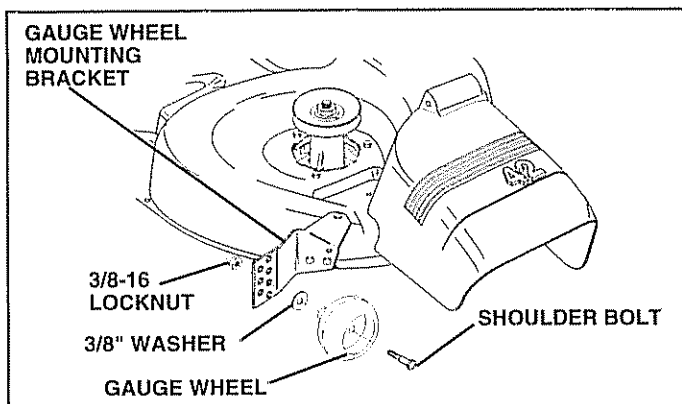

FIG. 5A

## INSTALL MULCHER PLATE (See Figs. 5B and 5C)

- Install two latch hooks to mulcher plate using screw, washer, lock washer, and weld nut as shown.

**NOTE:** Pre-assemble weld nut to latch hook by inserting weld nut from the top with hook pointing down.

- Tighten hardware securely.
- Raise and hold deflector shield in upright position.
- Place front of mulcher plate over front of mower deck opening and slide into place, as shown.
- Hook front latch into hole on front of mower deck.
- Hook rear latch into hole on back of mower deck.

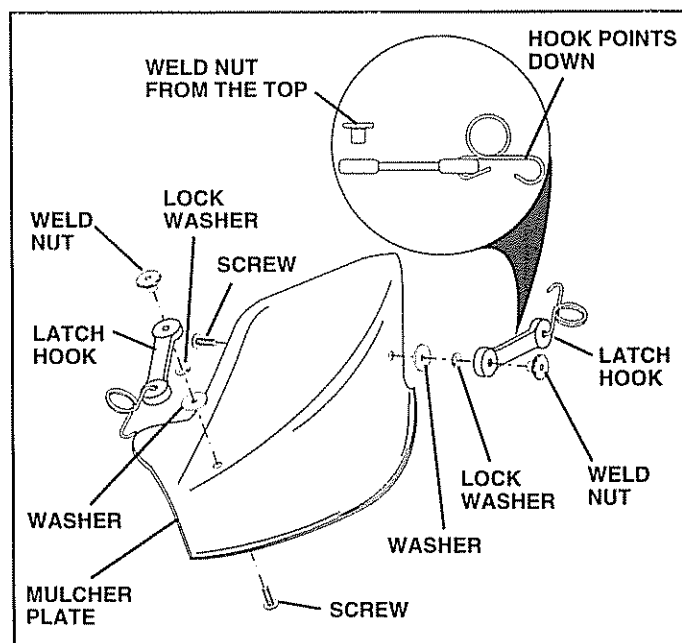
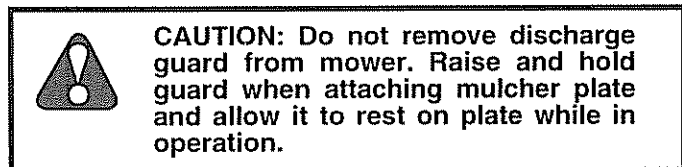

FIG. 5B

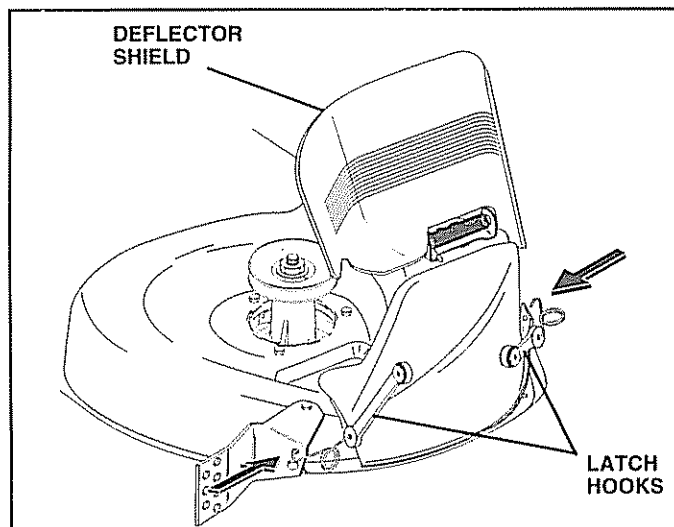

FIG. 5C

## TO CONVERT TO BAGGING OR DISCHARGING

Simply remove mulcher plate and store in a safe place. Your mower is now ready for discharging or installation of optional grass catcher accessory.

**NOTE:** It is not necessary to change blades. The mulcher blades are designed for discharging and bagging also.

## ✓ CHECKLIST

*BEFORE YOU OPERATE AND ENJOY YOUR NEW TRACTOR, WE WISH TO ASSURE THAT YOU RECEIVE THE BEST PERFORMANCE AND SATISFACTION FROM THIS QUALITY PRODUCT.*

*PLEASE REVIEW THE FOLLOWING CHECKLIST:*

- ✓ All assembly instructions have been completed.
- ✓ No remaining loose parts in carton.
- ✓ Battery is properly prepared and charged. (Minimum 1 hour at 6 amps).
- ✓ Seat is adjusted comfortably and tightened securely.
- ✓ All tires are properly inflated. (For shipping purposes, the tires were overinflated at the factory).
- ✓ Be sure mower deck is properly leveled side-to-side/front-to-rear for best cutting results. (Tires must be properly inflated for leveling).
- ✓ Check mower and drive belts. Be sure they are routed properly around pulleys and inside all belt keepers.
- ✓ Check wiring. See that all connections are still secure and wires are properly clamped.

*WHILE LEARNING HOW TO USE YOUR TRACTOR, PAY EXTRA ATTENTION TO THE FOLLOWING IMPORTANT ITEMS:*

- ✓ Engine oil is at proper level.
- ✓ Fuel tank is filled with fresh, clean, regular unleaded gasoline.
- ✓ Become familiar with all controls - their location and function. Operate them before you start the engine.
- ✓ Be sure brake system is in safe operating condition.

# OPERATION

These symbols may appear on your tractor or in literature supplied with the product. Learn and understand their meaning.



BATTERY

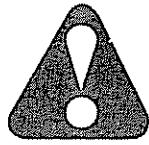

CAUTION OR WARNING



REVERSE



FORWARD



FAST



SLOW

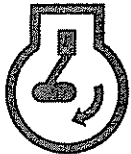

ENGINE ON



ENGINE OFF



OIL PRESSURE



CLUTCH



LIGHTS ON



OVER TEMP LIGHT

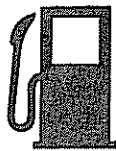

FUEL



CHOKE

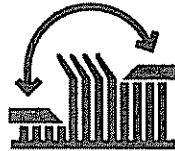

MOWER HEIGHT

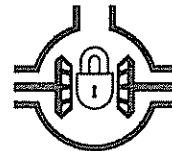

DIFFERENTIAL LOCK



PARKING BRAKE LOCKED



UNLOCKED



MOWER LIFT

R

REVERSE

N

NEUTRAL

H

HIGH

L

LOW

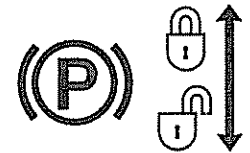

PARKING BRAKE



ATTACHMENT CLUTCH ENGAGED



ATTACHMENT CLUTCH DISENGAGED

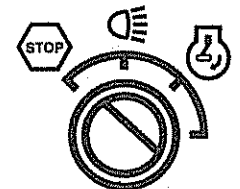

IGNITION

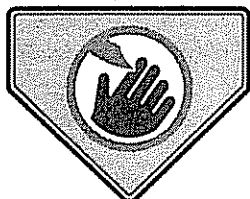

DANGER, KEEP HANDS AND FEET AWAY

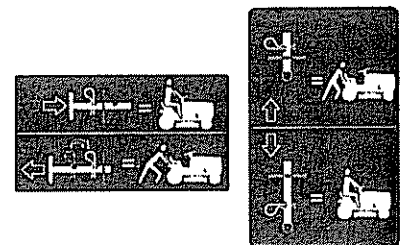

HYDROSTATIC FREE WHEEL (Hydro Models only)

# OPERATION

## KNOW YOUR TRACTOR

### READ THIS OWNER'S MANUAL AND SAFETY RULES BEFORE OPERATING YOUR TRACTOR

Compare the illustrations with your tractor to familiarize yourself with the locations of various controls and adjustments. Save this manual for future reference.

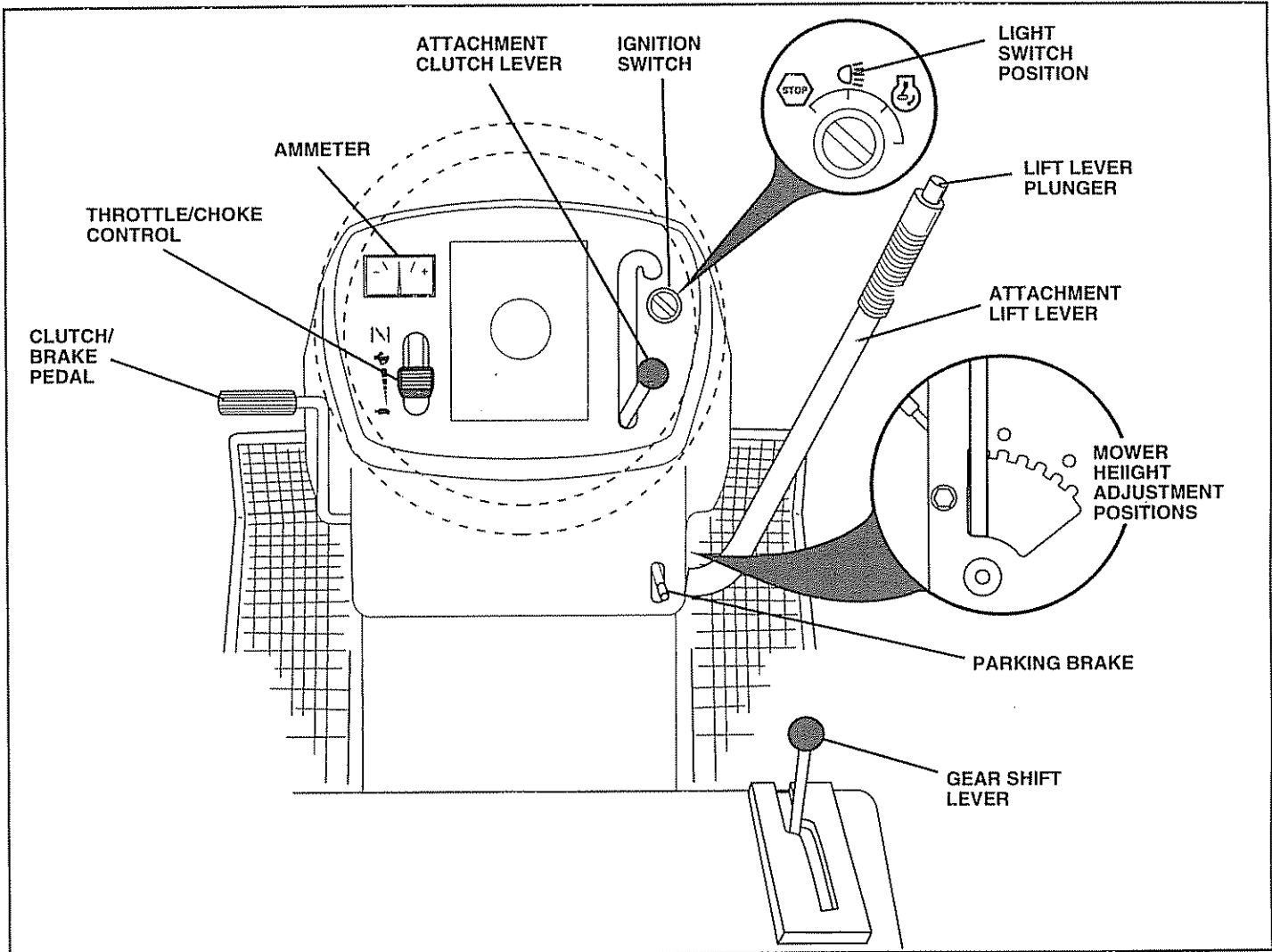

FIG. 8

Our tractors conform to the safety standards of the American National Standards Institute.

**ATTACHMENT CLUTCH LEVER:** Used to engage the mower blades, or other attachments mounted to your tractor.

**LIGHT SWITCH:** Turns the headlights on and off.

**THROTTLE/CHOKE CONTROL:** Used to control engine speed.

**CLUTCH/BRAKE PEDAL:** Used for declutching and braking the tractor and starting the engine.

**PARKING BRAKE:** Locks clutch/brake pedal into the brake position.

**GEAR SHIFT LEVER** - Selects the speed and direction of the tractor.

**ATTACHMENT LIFT LEVER:** Used to raise and lower the mower deck or other attachments mounted to your tractor.

**LIFT LEVER PLUNGER:** Used to release attachment lift lever when changing its position.

**IGNITION SWITCH:** Used for starting and stopping the engine.

**AMMETER:** Indicates battery charging (+) or discharging (-).

# OPERATION



The operation of any tractor can result in foreign objects thrown into the eyes, which can result in severe eye damage. Always wear safety glasses or eye shields while operating your tractor or performing any adjustments or repairs. We recommend a wide vision safety mask over the spectacles or standard safety glasses.

## HOW TO USE YOUR TRACTOR

### TO SET PARKING BRAKE (See Fig. 9)

Your tractor is equipped with an operator presence sensing switch. When engine is running, any attempt by the operator to leave the seat without first setting the parking brake will shut off the engine.

- Depress clutch/brake pedal into full "BRAKE" position and hold.
- Place parking brake lever in "ENGAGED" position and release pressure from clutch/brake pedal. Pedal should remain in "BRAKE" position. Make sure parking brake will hold tractor secure.

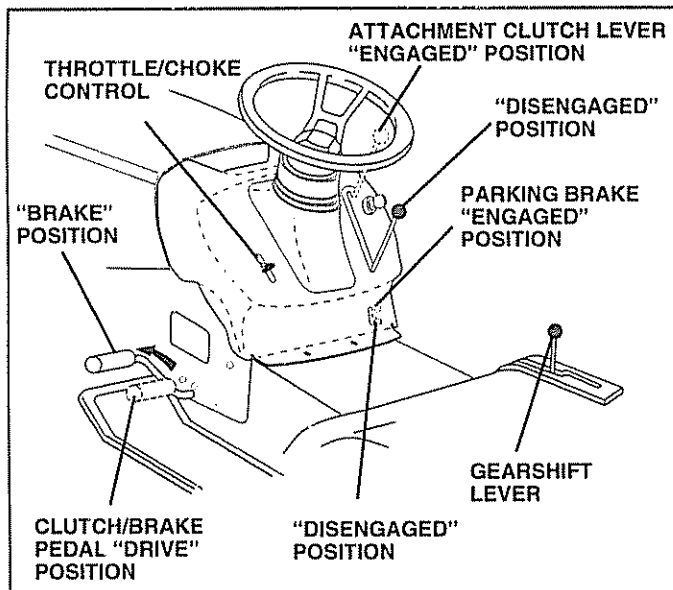

FIG. 9

### STOPPING (See Fig. 9)

#### MOWER BLADES -

- Move attachment clutch lever to "DISENGAGED" position.

#### GROUND DRIVE -

- Depress clutch/brake pedal into full "BRAKE" position.
- Move gearshift lever to neutral (N) position.

#### ENGINE -

- Move throttle control to slow position.

**NOTE:** Failure to move throttle control to slow position and allowing engine to idle before stopping may cause engine to "backfire".

- Turn ignition key to "OFF" position and remove key. Always remove key when leaving tractor to prevent unauthorized use.
- Never use choke to stop engine.

**NOTE:** Under certain conditions when tractor is standing idle with the engine running, hot engine exhaust gases may cause "browning" of grass. To eliminate this possibility, always stop engine when stopping tractor on grass areas.



**CAUTION:** Always stop tractor completely, as described above, before leaving the operator's position; to empty grass catcher, etc.

### TO USE THROTTLE CONTROL (See Fig. 9)

Always operate engine at full throttle.

- Operating engine at less than full throttle reduces the battery charging rate.
- Full throttle offers the best bagging and mower performance

### TO MOVE FORWARD AND BACKWARD (See Fig. 9)

The direction and speed of movement is controlled by the gearshift lever.

- Start tractor with clutch/brake pedal depressed and gearshift lever in neutral (N) position.
- Move gearshift lever to desired position.
- Slowly release clutch/brake pedal to start movement.

**IMPORTANT:** BRING TRACTOR TO A COMPLETE STOP BEFORE SHIFTING OR CHANGING GEARS. FAILURE TO DO SO WILL SHORTEN THE USEFUL LIFE OF YOUR TRANSAXLE

### TO ADJUST MOWER CUTTING HEIGHT (See Fig. 9)

The position of the attachment lift lever determines the cutting height.

- Grasp lift lever.
- Press plunger with thumb and move lever to desired position.

The cutting height range is approximately 1-1/2 to 4". The heights are measured from the ground to the blade tip with the engine not running. These heights are approximate and may vary depending upon soil conditions, height of grass and types of grass being mowed.

- The average lawn should be cut to approximately 2-1/2 inches during the cool season and to over 3 inches during hot months. For healthier and better looking lawns, mow often and after moderate growth.
- For best cutting performance, grass over 6 inches in height should be mowed twice. Make the first cut relatively high; the second to desired height.

# OPERATION

## TO OPERATE MOWER (See Fig. 10)

Your tractor is equipped with an operator presence sensing switch. Any attempt by the operator to leave the seat with the engine running and the attachment clutch engaged will shut off the engine.

- Select desired height of cut.
- Start mower blades by engaging attachment clutch control.
- TO STOP MOWER BLADES - disengage attachment clutch control.



**CAUTION:** Do not operate the mower without either the entire grass catcher, on mowers so equipped, or the discharge guard in place.

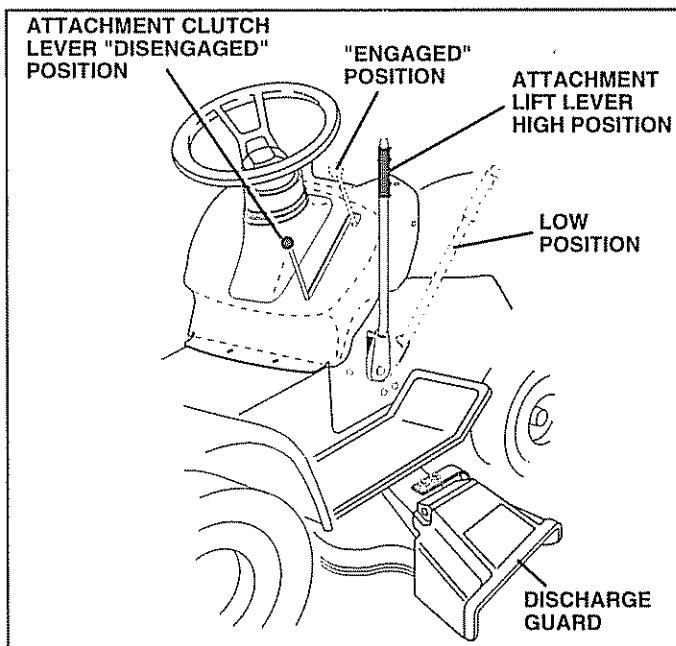

FIG. 10

## TO OPERATE ON HILLS



**CAUTION:** Do not drive up or down hills with slopes greater than 15° and do not drive across any slope.

- Choose the slowest speed before starting up or down hills.
- Avoid stopping or changing speed on hills.
- If slowing is necessary, move throttle control lever to slower position.
- If stopping is absolutely necessary, push clutch/brake pedal quickly to brake position and engage parking brake.
- Move gearshift lever to 1st gear. Be sure you have allowed room for tractor to roll slightly as you restart movement.

- To restart movement, slowly release parking brake and clutch/brake pedal.
- Make all turns slowly.

## TO TRANSPORT

- Raise attachment lift to highest position with attachment lift control.
- When pushing or towing your tractor, be sure gearshift lever is in neutral (N) position.
- Do not push or tow tractor at more than five (5) MPH.

**NOTE:** To protect hood from damage when transporting your tractor on a truck or a trailer, be sure hood is closed and secured to tractor. Use an appropriate means of tying hood to tractor (rope, cord, etc.).

## BEFORE STARTING THE ENGINE

### CHECK ENGINE OIL LEVEL (See Fig. 17)

- The engine in your tractor has been shipped, from the factory, already filled with summer weight oil.
- Check engine oil with tractor on level ground.
- Unthread and remove oil fill cap/dipstick; wipe oil off. Reinsert the dipstick into the tube and rest oil fill cap on the tube. Do not thread the cap onto the tube. Remove and read oil level. If necessary, add oil until "FULL" mark on dipstick is reached. Do not overfill.
- For cold weather operation you should change oil for easier starting (See "OIL VISCOSITY CHART" in the Customer Responsibilities section of this manual).
- To change engine oil, see the Customer Responsibilities section in this manual.

### ADD GASOLINE

- Fill fuel tank. Use fresh, clean, regular unleaded gasoline with a minimum of 87 octane. (Use of leaded gasoline will increase carbon and lead oxide deposits and reduce valve life). Do not mix oil with gasoline. Purchase fuel in quantities that can be used within 30 days to assure fuel freshness.

**IMPORTANT:** WHEN OPERATING IN TEMPERATURES BELOW 32°F(0°C), USE FRESH, CLEAN WINTER GRADE GASOLINE TO HELP INSURE GOOD COLD WEATHER STARTING.

**WARNING:** Experience indicates that alcohol blended fuels (called gasohol or using ethanol or methanol) can attract moisture which leads to separation and formation of acids during storage. Acidic gas can damage the fuel system of an engine while in storage. To avoid engine problems, the fuel system should be emptied before storage of 30 days or longer. Drain the gas tank, start the engine and let it run until the fuel lines and carburetor are empty. Use fresh fuel next season. See Storage Instructions for additional information. Never use engine or carburetor cleaner products in the fuel tank or permanent damage may occur.



**CAUTION:** Fill to bottom of gas tank filler neck. Do not overfill. Wipe off any spilled oil or fuel. Do not store, spill or use gasoline near an open flame.

# OPERATION

## TO START ENGINE (See Fig. 9)

When starting the engine for the first time or if the engine has run out of fuel, it will take extra cranking time to move fuel from the tank to the engine.

- Sit on seat in operating position, depress clutch/brake pedal and set parking brake.
- Place gear shift lever in neutral (N) position.
- Move attachment clutch to "DISENGAGED" position.
- Move throttle control to choke position.

**Note:** Before starting, read the warm and cold starting procedures below.

- Insert key into ignition and turn key clockwise to "START" position and release key as soon as engine starts. Do not run starter continuously for more than fifteen seconds per minute. If the engine does not start after several attempts, move throttle control to fast position, wait a few minutes and try again. If engine still does not start, move the throttle control back to the choke position and retry.

## WARM WEATHER STARTING (50° F and above)

- When engine starts, move the throttle control to the fast position.
- The attachments and ground drive can now be used. If the engine does not accept the load, restart the engine and allow it to warm up for one minute using the choke as described above.

## COLD WEATHER STARTING ( 50° F and below)

- When engine starts, allow engine to run with the throttle control in the choke position until the engine runs roughly, then move throttle control to fast position. This may require an engine warm-up period from several seconds to several minutes, depending on the temperature.
- The attachments can also be used during the engine warm-up period.

**NOTE:** If at a high altitude (above 3000 feet) or in cold temperatures (below 32 F) the carburetor fuel mixture may need to be adjusted for best engine performance. See "TO ADJUST CARBURETOR" in the Service and Adjustments section of this manual.

## MOWING TIPS

- Mower should be properly leveled for best mowing performance. See "TO LEVEL MOWER HOUSING" in the Service and Adjustments section of this manual.
- The left hand side of mower should be used for trimming.
- Drive so that clippings are discharged onto the area that has been cut. Have the cut area to the right of the machine. This will result in a more even distribution of clippings and more uniform cutting.
- When mowing large areas, start by turning to the right so that clippings will discharge away from shrubs, fences, driveways, etc. After one or two rounds, mow in the opposite direction making left hand turns until finished (See Fig. 11A).
- If grass is extremely tall, it should be mowed twice to reduce load and possible fire hazard from dried clippings. Make first cut relatively high; the second to the desired height.

- Do not mow grass when it is wet. Wet grass will plug mower and leave undesirable clumps. Allow grass to dry before mowing.
- Always operate engine at full throttle when mowing to assure better mowing performance and proper discharge of material. Regulate ground speed by selecting a low enough gear to give the mower cutting performance as well as the quality of cut desired.
- When operating attachments, select a ground speed that will suit the terrain and give best performance of the attachment being used.

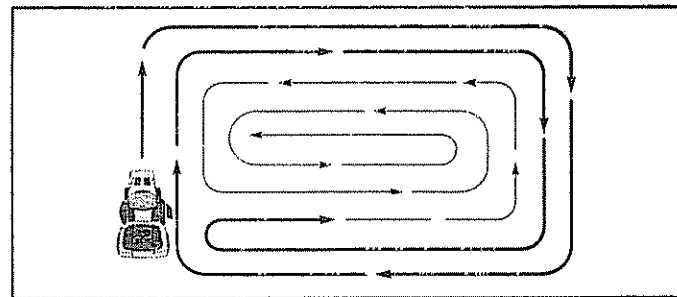

FIG. 11A

## MULCHING MOWING TIPS

**IMPORTANT:** FOR BEST PERFORMANCE, KEEP MOWER HOUSING FREE OF BUILT-UP GRASS AND TRASH. CLEAN AFTER EACH USE.

- The special mulching blade will recut the grass clippings many times and reduce them in size so that as they fall onto the lawn they will disperse into the grass and not be noticed. Also, the mulched grass will biodegrade quickly to provide nutrients for the lawn. Always mulch with your highest engine (blade) speed as this will provide the best recutting action of the blades.
- Avoid cutting your lawn when it is wet. Wet grass tends to form clumps and interferes with the mulching action. The best time to mow your lawn is the early afternoon. At this time the grass has dried and the newly cut area will not be exposed to the direct sun.
- For best results, adjust the mower cutting height so that the mower cuts off only the top one-third of the grass blades (See Fig. 11B). For extremely heavy mulching, reduce your width of cut on each pass and mow slowly.
- Certain types of grass and grass conditions may require that an area be mulched a second time to completely hide the clippings. When doing a second cut, mow across or perpendicular to the first cut path.
- Change your cutting pattern from week to week. Mow north to south one week then change to east to west the next week. This will help prevent matting and graining of the lawn.

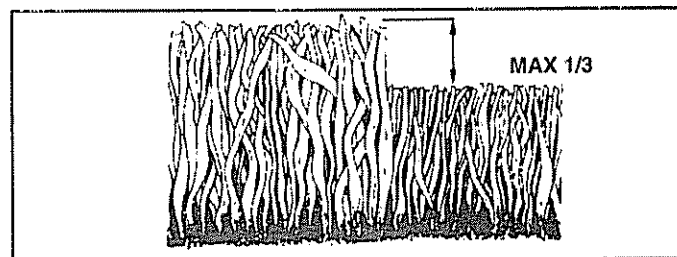

FIG. 11B

# CUSTOMER RESPONSIBILITIES

MAINTENANCE SCHEDULE FILL IN DATES AS YOU COMPLETE REGULAR SERVICE		SERVICE INTERVALS							SERVICE DATES				
		BEFORE EACH USE	EVERY 8 HOURS	EVERY 25 HOURS	EVERY 50 HOURS	EVERY 100 HOURS	EVERY SEASON	BEFORE STORAGE					
TRACTOR	Check Brake Operation	✓	✓										
	Check Tire Pressure	✓	✓										
	Check for Loose Fasteners	✓				✓ <sub>7</sub>		✓					
	Sharpen/Replace Mower Blades			✓ <sub>4</sub>									
	Lubrication Chart			✓				✓					
	Check Battery Level/Recharge			✓ <sub>6</sub>									
	Clean Battery and Terminals			✓				✓					
	Check Transaxle Cooling			✓									
	Adjust Blade Belt(s) Tension					✓ <sub>5</sub>							
	Adjust Motion Drive Belt(s) Tension					✓ <sub>5</sub>							
ENGINE	Check Engine Oil Level	✓	✓										
	Change Engine Oil			✓ <sub>1,2,3</sub>				✓					
	Clean Air Filter			✓ <sub>2</sub>									
	Clean Air Screen			✓ <sub>2</sub>									
	Inspect Muffler/Spark Arrester				✓								
	Replace Oil Filter (If equipped)					✓ <sub>1,2</sub>							
	Clean Engine Cooling Fins					✓ <sub>2</sub>							
	Replace Spark Plug					✓		✓					
	Replace Air Filter Paper Cartridge					✓ <sub>2</sub>							
	Replace Fuel Filter							✓					

- 1 - Change more often when operating under a heavy load or in high ambient temperatures
- 2 - Service more often when operating in dirty or dusty conditions
- 3 - If equipped with oil filter, change oil every 50 hours
- 4 - Replace blades more often when mowing in sandy soil

- 5 - If equipped with adjustable system
- 6 - Not required if equipped with maintenance-free battery
- 7 - Tighten front axle pivot bolt to 35 ft.-lbs. maximum  
Do not overtighten.

## GENERAL RECOMMENDATIONS

The warranty on this tractor does not cover items that have been subjected to operator abuse or negligence. To receive full value from the warranty, operator must maintain tractor as instructed in this manual.

Some adjustments will need to be made periodically to properly maintain your tractor.

All adjustments in the Service and Adjustments section of this manual should be checked at least once each season.

- Once a year you should replace the spark plug, clean or replace air filter, and check blades and belts for wear. A new spark plug and clean air filter assure proper air-fuel mixture and help your engine run better and last longer.

## BEFORE EACH USE

- Check engine oil level.
- Check brake operation.
- Check tire pressure.
- Check for loose fasteners.

## LUBRICATION CHART

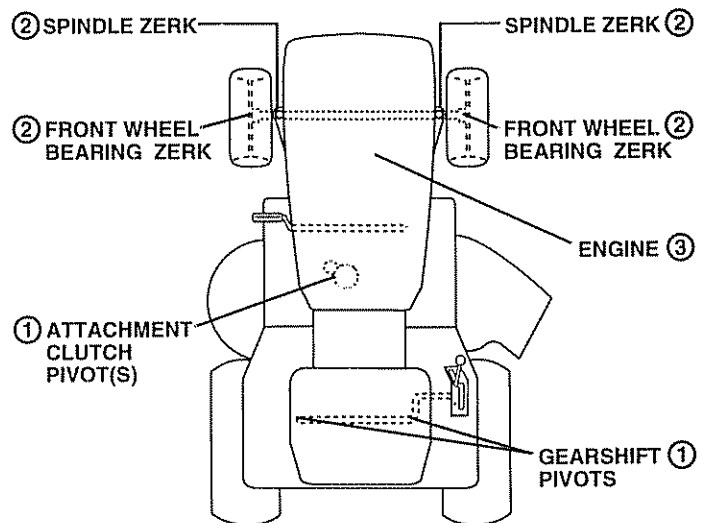

- ① SAE 30 OR 10W30 MOTOR OIL
- ② GENERAL PURPOSE GREASE
- ③ REFER TO CUSTOMER RESPONSIBILITIES "ENGINE" SECTION

**IMPORTANT:** DO NOT OIL OR GREASE THE PIVOT POINTS WHICH HAVE SPECIAL NYLON BEARINGS. VISCOUS LUBRICANTS WILL ATTRACT DUST AND DIRT THAT WILL SHORTEN THE LIFE OF THE SELF-LUBRICATING BEARINGS. IF YOU FEEL THEY MUST BE LUBRICATED, USE ONLY A DRY, POWDERED GRAPHITE TYPE LUBRICANT SPARINGLY.



# CUSTOMER RESPONSIBILITIES

## TRACTOR

Always observe safety rules when performing any maintenance.

## BRAKE OPERATION

If tractor requires more than six (6) feet stopping distance at high speed in highest gear, then brake must be adjusted. (See "TO ADJUST BRAKE" in the Service and Adjustments section of this manual).

## TIRES

- Maintain proper air pressure in all tires (See "PRODUCT SPECIFICATIONS" on page 3 of this manual).
- Keep tires free of gasoline, oil, or insect control chemicals which can harm rubber.
- Avoid stumps, stones, deep ruts, sharp objects and other hazards that may cause tire damage.

**NOTE:** To seal tire punctures and prevent flat tires due to slow leaks, tire sealant may be purchased from your local parts dealer. Tire sealant also prevents tire dry rot and corrosion.

## BLADE CARE

For best results mower blades must be kept sharp. Replace bent or damaged blades.

## BLADE REMOVAL (See Fig. 13)

- Raise mower to highest position to allow access to blades.
- Remove hex bolt, lock washer and flat washer securing blade.
- Install new or resharpened blade with trailing edge up towards deck as shown.
- Reassemble hex bolt, lock washer and flat washer in exact order as shown.
- Tighten bolt securely (30-35 Ft. Lbs. torque).

**IMPORTANT:** BLADE BOLT IS GRADE 8 HEAT TREATED.

**NOTE:** We do not recommend sharpening blade - but if you do, be sure the blade is balanced.

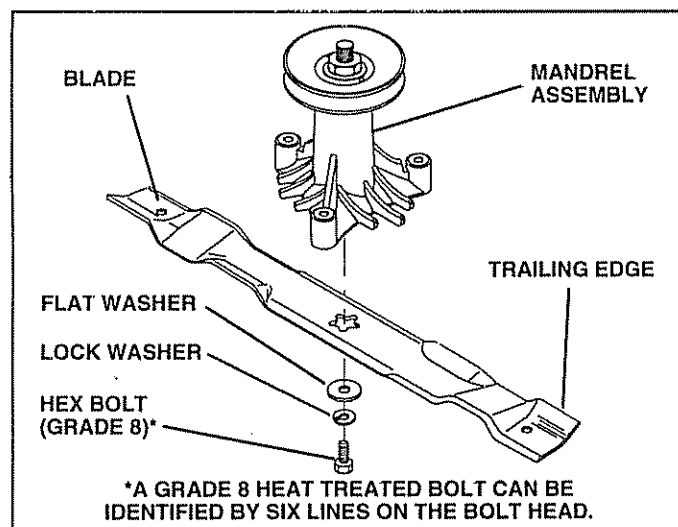

FIG. 13

## TO SHARPEN BLADE (See Fig. 14)

Care should be taken to keep the blade balanced. An unbalanced blade will cause excessive vibration and eventual damage to mower and engine.

- The blade can be sharpened with a file or on a grinding wheel. Do not attempt to sharpen while on the mower.
- To check blade balance, you will need a 5/8" diameter steel bolt, pin, or a cone balancer. (When using a cone balancer, follow the instructions supplied with balancer).
- Slide blade on to an unthreaded portion of the steel bolt or pin and hold the bolt or pin parallel with the ground. If blade is balanced, it should remain in a horizontal position. If either end of the blade moves downward, sharpen the heavy end until the blade is balanced.

**NOTE:** Do not use a nail for balancing blade. The lobes of the center hole may appear to be centered, but are not.

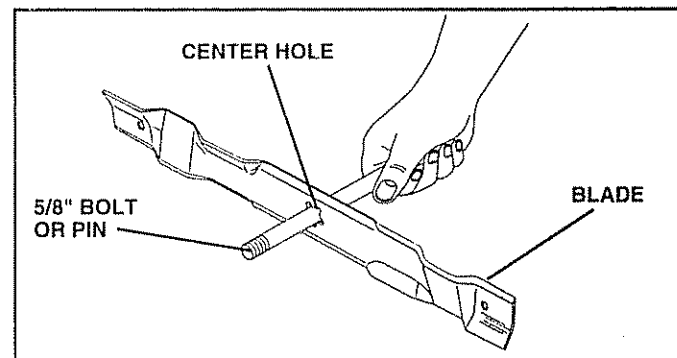

FIG. 14

## BATTERY

Your tractor has a battery charging system which is sufficient for normal use. However, periodic charging of the battery with an automotive charger will extend its life.

- Keep battery and terminals clean.
- Keep battery bolts tight.
- Keep small vent holes open.
- Recharge at 6-10 amperes for 1 hour.

## TO CLEAN BATTERY AND TERMINALS

Corrosion and dirt on the battery and terminals can cause the battery to "leak" power.

- Open battery box door.
- Disconnect BLACK battery cable first then RED battery cable and remove battery from tractor.
- Rinse the battery with plain water and dry.
- Clean terminals and battery cable ends with wire brush until bright.
- Coat terminals with grease or petroleum jelly.
- Reinstall battery (See "CONNECT BATTERY" in the Assembly section of this manual).

# CUSTOMER RESPONSIBILITIES

## V-BELTS

Check V-belts for deterioration and wear after 100 hours of operation and replace if necessary. The belts are not adjustable. Replace belts if they begin to slip from wear.

## TRANSAXLE COOLING

Keep transaxle free from build-up of dirt and chaff which can restrict cooling.

## ENGINE

### LUBRICATION

Only use high quality detergent oil rated with API service classification SF, SG, or SH. Select the oil's SAE viscosity grade according to your expected operating temperature.

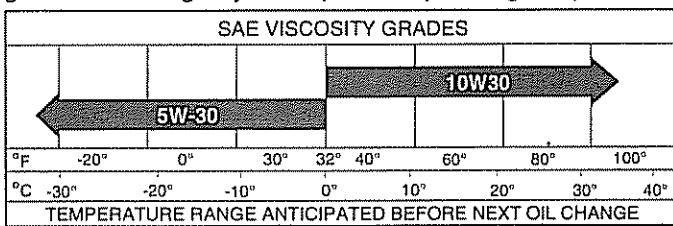

FIG. 15

Change the oil after every 50 hours of operation or at least once a year if the tractor is not used for 50 hours in one year.

Check the crankcase oil level before starting the engine and after each eight (8) hours of operation. Tighten oil fill cap/dipstick securely each time you check the oil level.

### TO CHANGE ENGINE OIL (See Figs. 15 and 16)

Determine temperature range expected before oil change. All oil must meet API service classification SF, SG or SH.

- Be sure tractor is on level surface.
- Oil will drain more freely when warm.
- Catch oil in a suitable container.
- Remove oil fill cap/dipstick. Be careful not to allow dirt to enter the engine when changing oil.
- Remove drain plug.
- After oil has drained completely, replace oil drain plug and tighten securely.
- Refill engine with oil through oil fill dipstick tube. Pour slowly. Do not overfill. For approximate capacity see "PRODUCT SPECIFICATIONS" on page 3 of this manual.
- Use gauge on oil fill cap/dipstick for checking level. Insert dipstick into the tube and rest the oil fill cap on the tube. Do not thread the cap onto the tube when taking reading. Keep oil at "FULL" line on dipstick. Tighten cap onto the tube securely when finished.

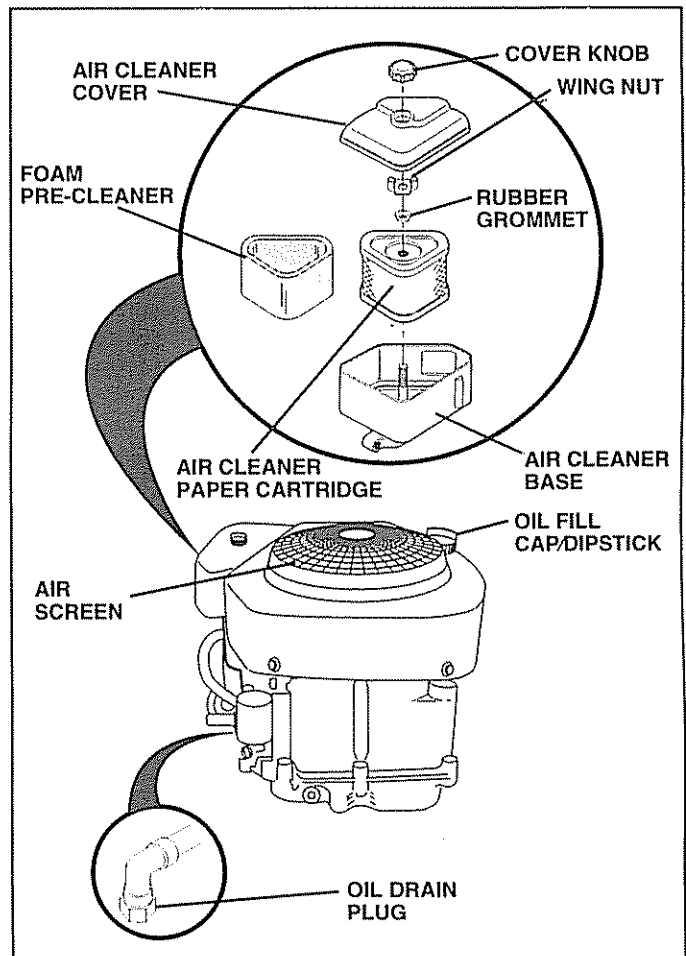

FIG. 16

---

# CUSTOMER RESPONSIBILITIES

---

## CLEAN AIR SCREEN (See Fig. 16)

Air screen must be kept free of dirt and chaff to prevent engine damage from overheating. Clean with a wire brush or compressed air to remove dirt and stubborn dried gum fibers.

## AIR FILTER (See Fig. 16)

Your engine will not run properly using a dirty air filter. Clean the foam pre-cleaner after every 25 hours of operation or every season. Service paper cartridge every 100 hours of operation or every season, whichever occurs first.

Service air cleaner more often under dusty conditions.

- Remove knob and cover.
- Remove wing nut and air cleaner from base.

### TO SERVICE PRE-CLEANER

- Slide foam pre-cleaner off cartridge.
- Wash it in liquid detergent and water.
- Squeeze it dry in a clean cloth. Allow it to dry.
- Saturate it in engine oil. Wrap it in clean, absorbent cloth and squeeze to remove excess oil.

### TO SERVICE CARTRIDGE

- Replace a dirty, bent, or damaged cartridge.

**NOTE:** Do not wash the paper cartridge or use pressurized air, as this will damage the cartridge.

- Reinstall the pre-cleaner (cleaned and oiled) over the paper cartridge.
- Reassemble air cleaner, wing nut, cover and tighten knob securely.

## CLEAN AIR INTAKE/COOLING AREAS

To insure proper cooling, make sure the grass screen, cooling fins, and other external surfaces of the engine are kept clean at all times.

Every 100 hours of operation (more often under extremely dusty, dirty conditions), remove the blower housing and other cooling shrouds. Clean the cooling fins and external surfaces as necessary. Make sure the cooling shrouds are reinstalled.

**NOTE:** Operating the engine with a blocked grass screen, dirty or plugged cooling fins, and/or cooling shrouds removed will cause engine damage due to overheating.

## MUFFLER

Inspect and replace corroded muffler and spark arrester (if equipped) as it could create a fire hazard and/or damage.

## SPARK PLUGS

Replace spark plugs at the beginning of each mowing season or after every 100 hours of operation, whichever occurs first. Spark plug type and gap setting are shown in "PRODUCT SPECIFICATIONS" on page 3 of this manual.

# CUSTOMER RESPONSIBILITIES

## ENGINE OIL FILTER (See Fig. 17)

Replace the engine oil filter every season or every other oil change if the tractor is used more than 100 hours in one year.

- Drain oil from engine crankcase (See "TO CHANGE ENGINE OIL" in this section of this manual, through step remove drain plug).
- Remove oil filter and wipe off filter adapter.
- Apply a thin coating of new engine oil to the rubber gasket on replacement oil filter.
- Install replacement oil filter on filter adapter. Turn oil filter clockwise until rubber gasket contacts the filter adapter, then tighten filter an additional 1/2 turn.
- Fill crankcase with new oil (See "TO CHANGE ENGINE OIL" in this section of this manual). For approximate capacity see "PRODUCT SPECIFICATIONS" on page 3 of this manual.
- Start the engine and check for oil leaks. Correct any leaks before placing engine into full operation.

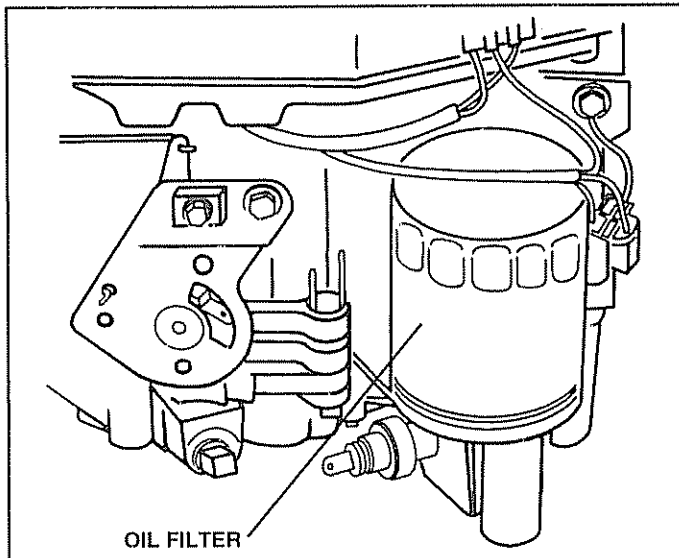

FIG. 17

## IN-LINE FUEL FILTER (See Fig. 18)

The fuel filter should be replaced once each season. If fuel filter becomes clogged, obstructing fuel flow to carburetor, replacement is required.

- With engine cool, remove filter and plug fuel line sections.
- Place new fuel filter in position in fuel line with arrow pointing towards carburetor.
- Be sure there are no fuel line leaks and clamps are properly positioned.
- Immediately wipe up any spilled gasoline.

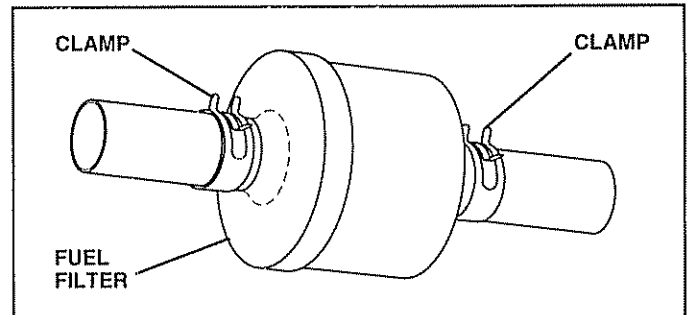

FIG. 18

## CLEANING

- Clean engine, battery, seat, finish, etc. of all foreign matter.
- Keep finished surfaces and wheels free of all gasoline, oil, etc.
- Protect painted surfaces with automotive type wax.

We do not recommend using a garden hose to clean your tractor unless the electrical system, muffler, air filter and carburetor are covered to keep water out. Water in engine can result in a shortened engine life.

# SERVICE AND ADJUSTMENTS



## CAUTION: BEFORE PERFORMING ANY SERVICE OR ADJUSTMENTS:

- Depress clutch/brake pedal fully and set parking brake.
- Place gearshift lever in neutral (N) position.
- Place attachment clutch in "DISENGAGED" position.
- Turn ignition key "OFF" and remove key.
- Make sure the blades and all moving parts have completely stopped.
- Disconnect spark plug wire from spark plug and place wire where it cannot come in contact with plug.

## TRACTOR

### TO REMOVE MOWER (See Fig. 19)

Mower will be easier to remove from the right side of tractor.

- Place attachment clutch in "DISENGAGED" position.
- Move attachment lift lever forward to lower mower to its lowest position.
- Roll belt off engine pulley.
- Disconnect clutch rod from clutch lever by removing retainer spring.
- Disconnect anti-sway bar from chassis bracket by removing retainer spring.
- Disconnect suspension arms from rear deck brackets by removing retainer springs.
- Disconnect front links from deck by removing retainer springs.
- Raise lift lever to raise suspension arms. Slide mower out from under tractor.

**IMPORTANT:** IF AN ATTACHMENT OTHER THAN THE MOWER IS TO BE MOUNTED TO THE TRACTOR, REMOVE THE FRONT LINKS.

### TO INSTALL MOWER (See Fig. 19)

- Raise attachment lift lever to its highest position.
- Slide mower under tractor with discharge guard to right side of tractor.
- Lower lift lever to its lowest position.
- Install mower in reverse order of removal instructions.

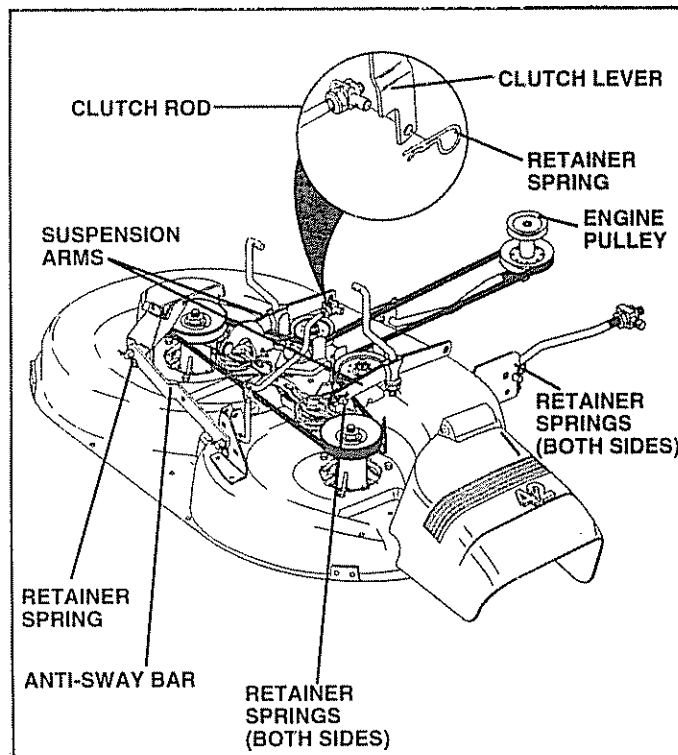

FIG. 19

# SERVICE AND ADJUSTMENTS

## TO LEVEL MOWER HOUSING

Adjust the mower while tractor is parked on level ground or driveway. Make sure tires are properly inflated (See "PRODUCT SPECIFICATIONS" on page 3 of this manual). If tires are over or underinflated, you will not properly adjust your mower.

### SIDE-TO-SIDE ADJUSTMENT (See Figs. 20 and 21)

- Raise mower to its highest position.
- At the midpoint of both sides of mower, measure height from bottom edge of mower to ground. Distance "A" on both sides of mower should be the same or within 1/4" of each other.
- If adjustment is necessary, make adjustment on one side of mower only.
- To raise one side of mower, tighten lift link adjustment nut on that side.
- To lower one side of mower, loosen lift link adjustment nut on that side.

**NOTE:** Each full turn of adjustment nut will change mower height about 1/8".

- Recheck measurements after adjusting.

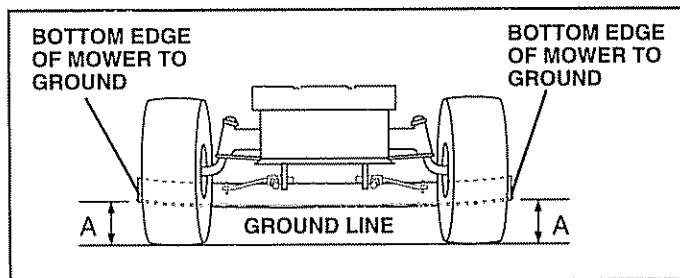

FIG. 20

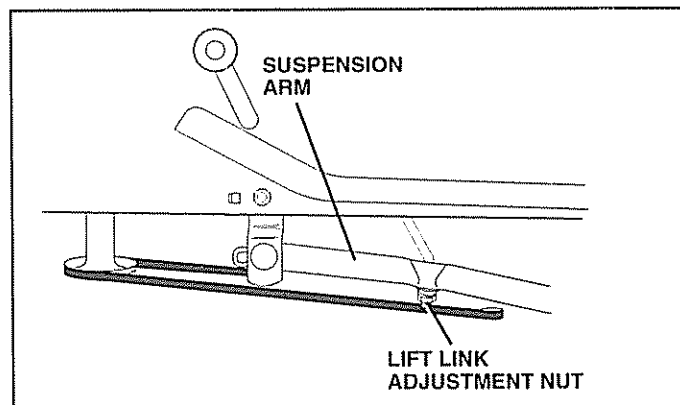

FIG. 21

### FRONT-TO-BACK ADJUSTMENT (See Figs. 22 and 23)

**IMPORTANT:** DECK MUST BE LEVEL SIDE-TO-SIDE. IF THE FOLLOWING FRONT-TO-BACK ADJUSTMENT IS NECESSARY, BE SURE TO ADJUST BOTH FRONT LINKS EQUALLY SO MOWER WILL STAY LEVEL SIDE-TO-SIDE.

To obtain the best cutting results, the mower housing should be adjusted so that the front is approximately 1/8" to 1/2" lower than the rear when the mower is in its highest position.

Check adjustment on right side of tractor. Measure distance "D" directly in front and behind the mandrel at bottom edge of mower housing as shown.

- Before making any necessary adjustments, check that both front links are equal in length. Both links should be approximately 10-3/8".
- If links are not equal in length, adjust one link to same length as other link.
- To lower front of mower loosen nut "E" on both front links an equal number of turns.
- When distance "D" is 1/8" to 1/2" lower at front than rear, tighten nuts "F" against trunnion on both front links.
- To raise front of mower, loosen nut "F" from trunnion on both front links. Tighten nut "E" on both front links an equal number of turns.
- When distance "D" is 1/8" to 1/2" lower at front than rear, tighten nut "F" against trunnion on both front links.
- Recheck side-to-side adjustment.

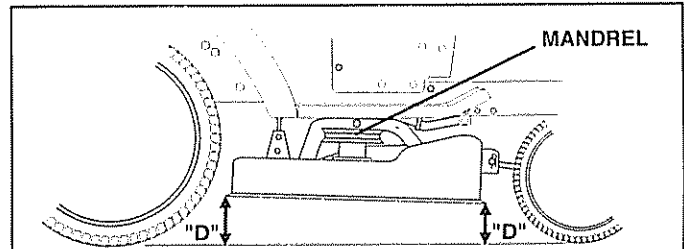

FIG. 22

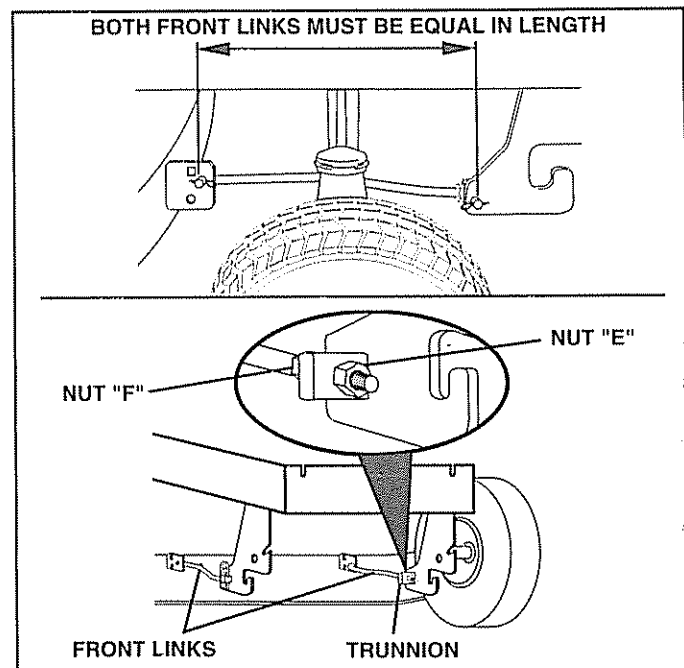

FIG. 23

# SERVICE AND ADJUSTMENTS

## TO REPLACE MOWER BLADE DRIVE BELT (See Fig. 24)

The mower blade drive belt may be replaced without tools. Park the tractor on level surface. Engage parking brake.

### BELT REMOVAL -

- Remove mower from tractor (See "TO REMOVE MOWER" in this section of this manual).
- Work belt off both mandrel pulleys and idler pulleys.
- Pull belt away from mower.

### BELT INSTALLATION -

- Install new belt in reverse order of removal.
- Make sure belt is in all pulley grooves and inside all belt guides.
- Install mower in reverse order of removal instructions.

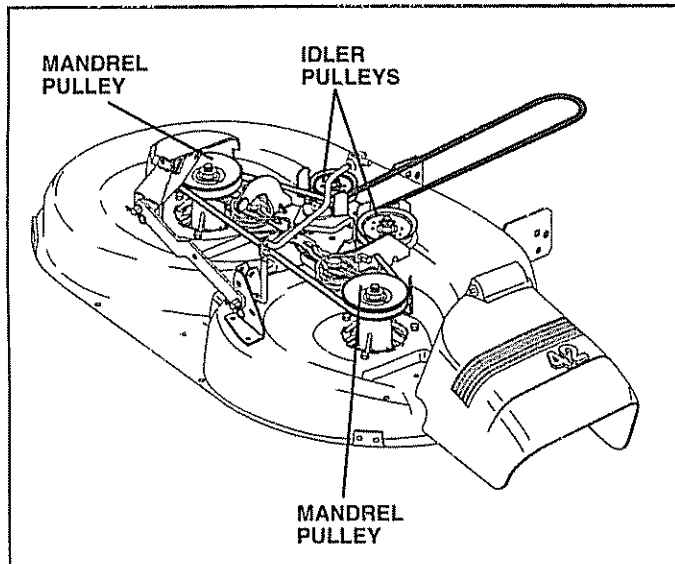

FIG. 24

## TO ADJUST BRAKE (See Fig. 25)

Your tractor is equipped with an adjustable brake system which is mounted on the right side of the transaxle.

If tractor requires more than six (6) feet stopping distance at high speed in highest gear, then brake must be adjusted.

- Depress clutch/brake pedal and engage parking brake.
- Measure distance between brake operating arm and nut "A" on brake rod.
- If distance is other than 1-1/2", loosen jam nut and turn nut "A" until distance becomes 1-1/2". Retighten jam nut against nut "A".
- Road test tractor for proper stopping distance as stated above. Readjust if necessary. If stopping distance is still greater than six (6) feet in highest gear, further maintenance is necessary. Contact your nearest authorized service center/department.

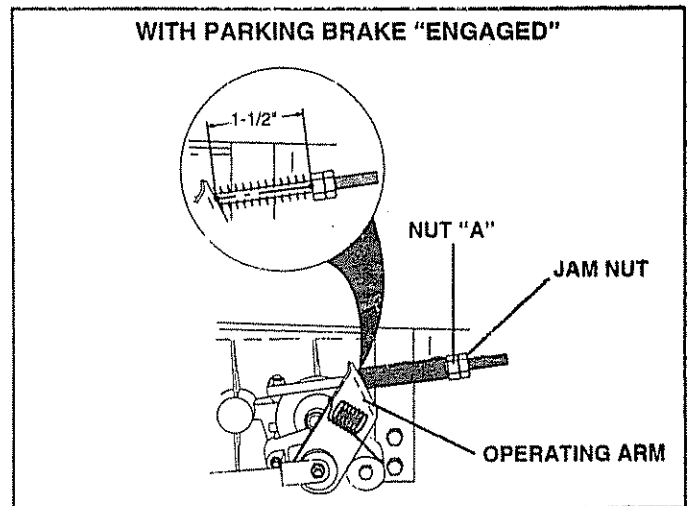

FIG. 25

## TO REPLACE MOTION DRIVE BELT (See Fig. 26)

Park the tractor on level surface. Engage parking brake. For assistance, there is a belt installation guide decal on bottom side of left footrest.

- Remove mower (See "TO REMOVE MOWER" in this section of this manual.)
- Remove upper belt keeper.
- Remove belt from stationary idler and clutching idler.
- Pull belt slack toward rear of tractor. Remove belt upwards from transaxle pulley by deflecting belt keepers.
- Pull belt toward front of tractor and remove downwards from around engine pulley.
- Install new belt by reversing above procedure.

**IMPORTANT: MAKE SURE UPPER BELT KEEPER IS POSITIONED PROPERLY BETWEEN LOCATOR TABS.**

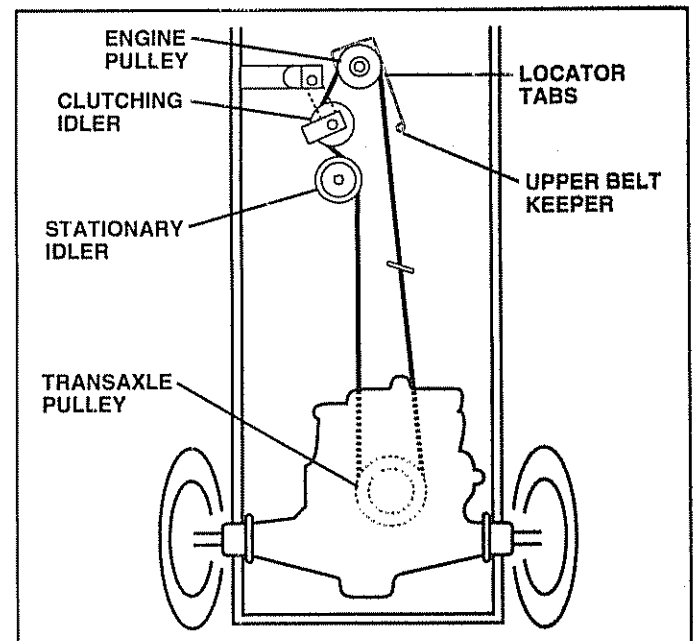

FIG. 26



# SERVICE AND ADJUSTMENTS

## TRANSAXLE SHIFTER LINKAGE AND ADJUSTMENT (See Figs. 27 and 28)

The transaxle should be in neutral when the gear shift lever is in the neutral (N) (lock gate) position. The adjustment is preset at the factory; however, if adjustment is needed, proceed as follows:

- Make sure transaxle is in neutral (N).
- Loosen two locknuts on tie rod.
- Turn center rod until gearshift lever falls into neutral lock gate on fender console.
- Tighten locknuts securely.

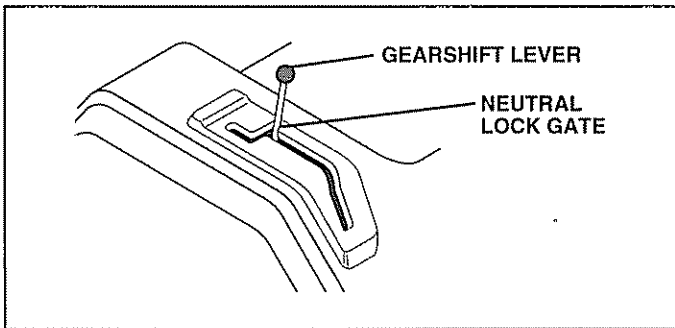

FIG. 27

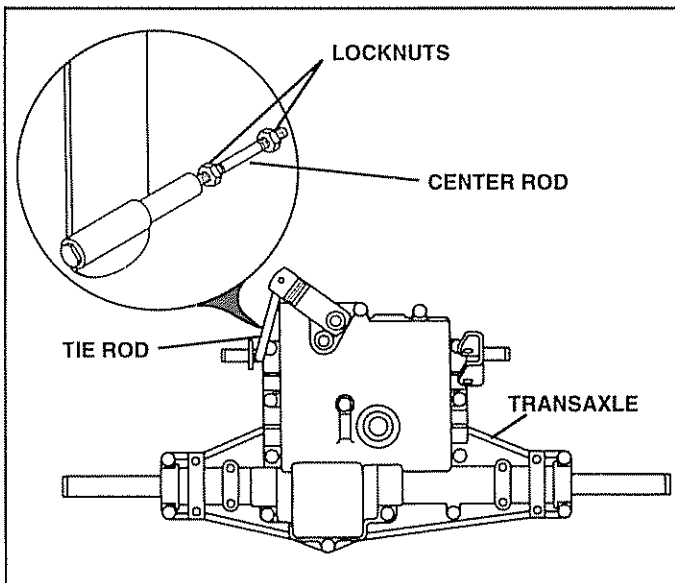

FIG. 28

## TO ADJUST STEERING WHEEL ALIGNMENT

If steering wheel crossbars are not horizontal (left to right) when wheels are positioned straight forward, remove steering wheel and reassemble per instructions in the Assembly section of this manual.

## FRONT WHEEL TOE-IN/CAMBER

The front wheel toe-in and camber are not adjustable on your tractor. If damage has occurred to affect the front wheel toe-in or camber, contact your nearest authorized service center/department.

## TO REMOVE WHEEL FOR REPAIRS (See Fig. 29)

- Block up axle securely.
- Remove axle cover, retaining ring and washers to allow wheel removal (rear wheel contains a square key - Do not lose).
- Repair tire and reassemble.
- On rear wheels only: align grooves in rear wheel hub and axle. Insert square key.
- Replace washers and snap retaining ring securely in axle groove.
- Replace axle cover.

**NOTE:** To seal tire punctures and prevent flat tires due to slow leaks, tire sealant may be purchased from your local parts dealer. Tire sealant also prevents tire dry rot and corrosion.

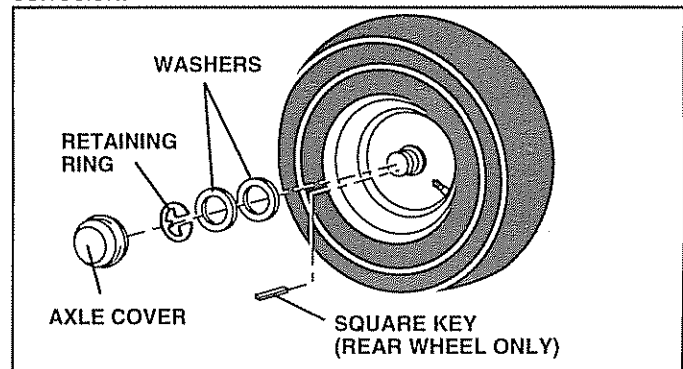

FIG. 29

## TO START ENGINE WITH A WEAK BATTERY (See Fig. 30)



**CAUTION:** Lead-acid batteries generate explosive gases. Keep sparks, flame and smoking materials away from batteries. Always wear eye protection when around batteries.

If your battery is too weak to start the engine, it should be recharged. If "jumper cables" are used for emergency starting, follow this procedure:

**IMPORTANT:** YOUR TRACTOR IS EQUIPPED WITH A 12 VOLT NEGATIVE GROUND SYSTEM. THE OTHER VEHICLE MUST ALSO BE A 12 VOLT NEGATIVE GROUND SYSTEM. DO NOT USE YOUR TRACTOR BATTERY TO START OTHER VEHICLES.

### TO ATTACH JUMPER CABLES -

- Connect each end of the RED cable to the POSITIVE (+) terminal of each battery, taking care not to short against chassis.
- Connect one end of the BLACK cable to the NEGATIVE (-) terminal of fully charged battery.
- Connect the other end of the BLACK cable to good CHASSIS GROUND, away from fuel tank and battery.

### TO REMOVE CABLES, REVERSE ORDER -

- BLACK cable first from chassis and then from the fully charged battery.
- RED cable last from both batteries.

# SERVICE AND ADJUSTMENTS

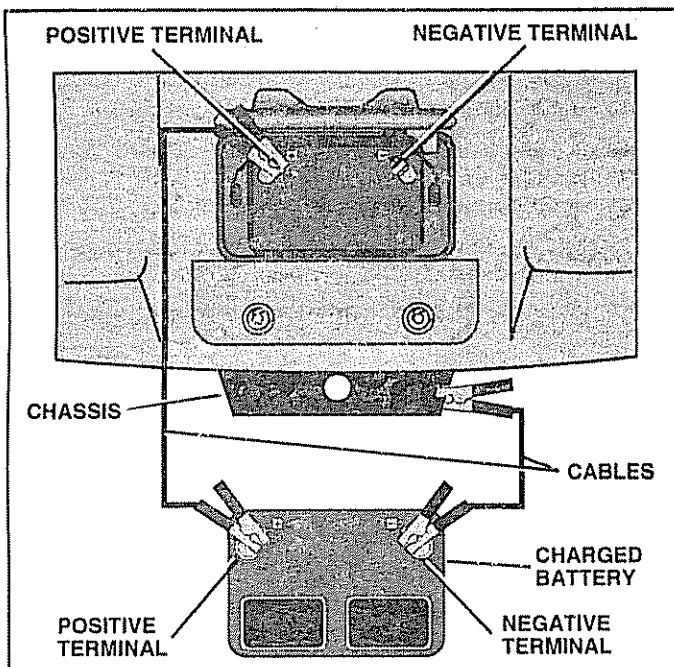

FIG. 30

## TO REPLACE HEADLIGHT BULB

- Raise hood.
- Pull bulb holder out of the hole in the backside of the grill.
- Replace bulb in holder and push bulb holder securely back into the hole in the backside of the grill.
- Close hood.

## INTERLOCKS AND RELAYS

Loose or damaged wiring may cause your tractor to run poorly, stop running, or prevent it from starting.

- Check wiring. See electrical wiring diagram in the Repair Parts section of this manual.

## TO REPLACE FUSE

Replace with 30 amp automotive-type plug-in fuse. The fuse holder is located behind the dash.

## TO REMOVE HOOD AND GRILL ASSEMBLY (See Fig. 31)

- Raise hood.
- Unsnap headlight wire connector.
- Stand in front of tractor. Grasp hood at sides, tilt toward engine and lift off of tractor.
- To replace, reverse above procedures.

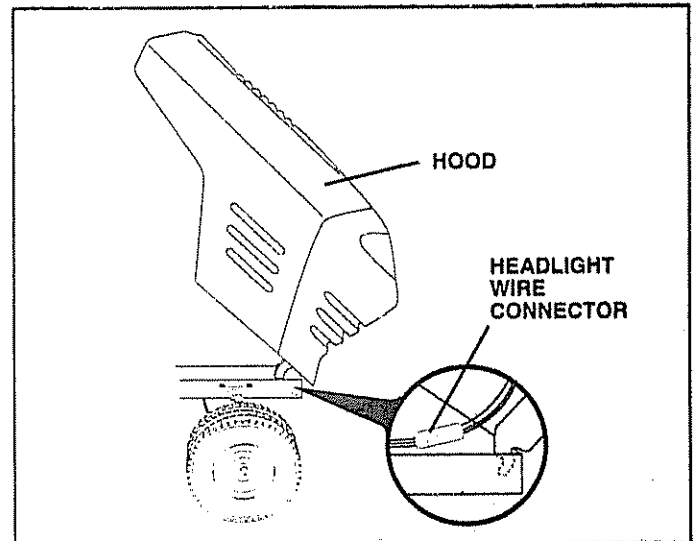

FIG. 31

# SERVICE AND ADJUSTMENTS

## ENGINE

### TO ADJUST THROTTLE CONTROL CABLE (See Fig. 32)

The throttle control has been preset at the factory and adjustment should not be necessary. Check adjustment as described below before loosening cable. If adjustment is necessary, proceed as follows:

- With engine not running, move throttle control lever from slow to choke position. Slowly move lever from choke to fast position.
- Check to see if hole in throttle lever and hole in speed control bracket are aligned.
- If holes are not aligned, loosen cable clamp screw and align the holes by inserting a pencil or a 1/4" drill bit through both holes.
- Pull throttle cable up to remove slack and tighten cable clamp screw. Remove alignment pencil or drill bit.

### TO ADJUST CARBURETOR (See Fig. 33)

The carburetor has been preset at the factory and adjustment should not be necessary. However, minor adjustment may be required to compensate for differences in fuel, temperature, altitude or load. If the carburetor does need adjustment, proceed as follows:

In general, turning the adjusting needles **in** (clockwise) decreases the supply of fuel to the engine giving a leaner fuel/air mixture. Turning the adjusting needles **out** (counterclockwise) increases the supply of fuel to the engine giving a richer fuel/air mixture.

**IMPORTANT:** DAMAGE TO THE NEEDLES AND THE SEATS IN CARBURETOR MAY RESULT IF NEEDLE IS TURNED IN TOO TIGHT.

**NOTE:** The carburetor on this engine is low emission. It is equipped with an idle fuel adjusting needle with a limiter cap, which allows some adjustment within the limits allowed by the cap. Do not attempt to remove the limiter cap. The limiter cap cannot be removed without breaking the adjusting needle.

- Be sure you have a clean air filter and the throttle control cable is adjusted properly (see above).
- Start engine and allow to warm for five minutes. Make adjustments with engine running and shift/motion control lever in neutral (N) position.
- Idle speed setting - With throttle control lever in slow position, engine should idle at 1750 RPM. If engine idles too slow or fast, turn idle speed adjusting screw in or out until correct idle is attained.
- Idle fuel needle setting - With throttle control lever in slow position, turn idle fuel adjustment needle **in** (clockwise) until engine begins to die and then turn **out** (counterclockwise) until engine runs rough. Turn needle to a point midway between those two positions.
- Recheck idle speed. Readjust if necessary.

### ACCELERATION TEST -

- Move throttle control lever from slow to fast position. If engine hesitates or dies, turn idle fuel adjusting needle **out** (counterclockwise) 1/8 turn. Repeat test and continue to adjust, if necessary, until engine accelerates smoothly.

High speed stop is factory adjusted. Do not adjust - damage may result.

**IMPORTANT:** NEVER TAMPER WITH THE ENGINE GOVERNOR, WHICH IS FACTORY SET FOR PROPER ENGINE SPEED. OVERSPEEDING THE ENGINE ABOVE THE FACTORY HIGH SPEED SETTING CAN BE DANGEROUS. IF YOU THINK THE ENGINE-GOVERNED HIGH SPEED NEEDS ADJUSTING, CONTACT YOUR NEAREST AUTHORIZED SERVICE CENTER/DEPARTMENT, WHICH HAS PROPER EQUIPMENT AND EXPERIENCE TO MAKE ANY NECESSARY ADJUSTMENTS.

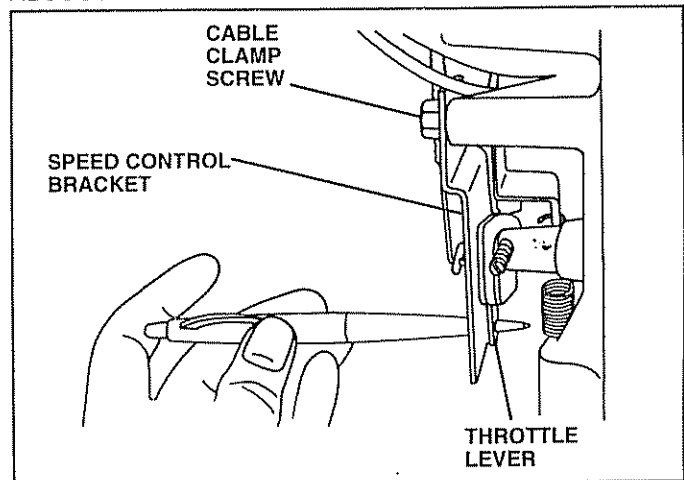

FIG. 32

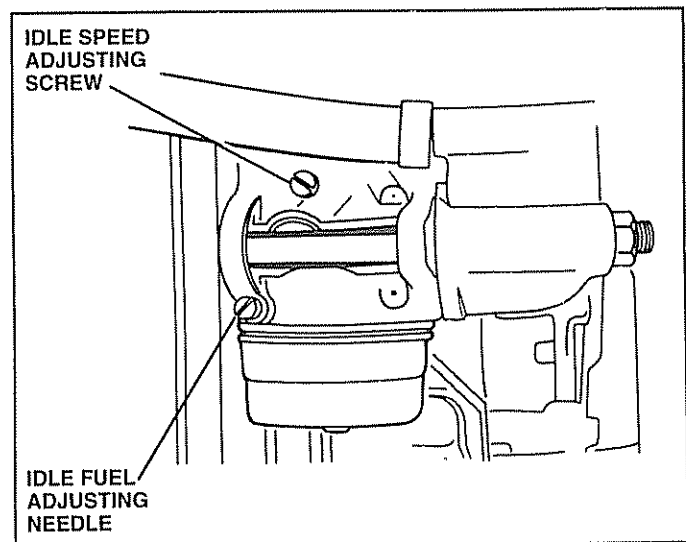

FIG. 33

---

# STORAGE

---

Immediately prepare your tractor for storage at the end of the season or if the tractor will not be used for 30 days or more.



**CAUTION:** Never store the tractor with gasoline in the tank inside a building where fumes may reach an open flame or spark. Allow the engine to cool before storing in any enclosure.

## TRACTOR

Remove mower from tractor for winter storage. When mower is to be stored for a period of time, clean it thoroughly, remove all dirt, grease, leaves, etc. Store in a clean, dry area.

- Clean entire tractor (See "CLEANING" in the Customer Responsibilities section of this manual).
- Inspect and replace belts, if necessary (See belt replacement instructions in the Service and Adjustments section of this manual).
- Lubricate as shown in the Customer Responsibilities section of this manual.
- Be sure that all nuts, bolts and screws are securely fastened. Inspect moving parts for damage, breakage and wear. Replace if necessary.
- Touch up all rusted or chipped paint surfaces; sand lightly before painting.

## BATTERY

- Fully charge the battery for storage.
- After a period of time in storage, battery may require recharging.
- To help prevent corrosion and power leakage during long periods of storage, battery cables should be disconnected and battery cleaned thoroughly (see "TO CLEAN BATTERY AND TERMINALS" in the Customer Responsibilities section of this manual).
- After cleaning, leave cables disconnected and place cables where they cannot come in contact with battery terminals.
- Be sure battery drain tube is securely attached.
- If battery is removed from tractor for storage, do not store battery directly on concrete or damp surfaces.

## ENGINE

### FUEL SYSTEM

**IMPORTANT:** IT IS IMPORTANT TO PREVENT GUM DEPOSITS FROM FORMING IN ESSENTIAL FUEL SYSTEM PARTS SUCH AS CARBURETOR, FUEL FILTER, FUEL HOSE, OR TANK DURING STORAGE. ALSO, EXPERIENCE INDICATES THAT ALCOHOL BLENDED FUELS (CALLED GASOHOL OR USING ETHANOL OR METHANOL) CAN ATTRACT MOISTURE WHICH LEADS TO SEPARATION AND FORMATION OF ACIDS DURING STORAGE. ACIDIC GAS CAN DAMAGE THE FUEL SYSTEM OF AN ENGINE WHILE IN STORAGE.

- Drain the fuel tank.
- Start the engine and let it run until the fuel lines and carburetor are empty.
- Never use engine or carburetor cleaner products in the fuel tank or permanent damage may occur.
- Use fresh fuel next season.

**NOTE:** Fuel stabilizer is an acceptable alternative in minimizing the formation of fuel gum deposits during storage. Add stabilizer to gasoline in fuel tank or storage container. Always follow the mix ratio found on stabilizer container. Run engine at least 10 minutes after adding stabilizer to allow the stabilizer to reach the carburetor. Do not drain the gas tank and carburetor if using fuel stabilizer.

### ENGINE OIL

Drain oil (with engine warm) and replace with clean engine oil. (See "ENGINE" in the Customer Responsibilities section of this manual).

### CYLINDERS

- Remove spark plug(s).
- Pour one ounce of oil through spark plug hole(s) into cylinder(s).
- Turn ignition key to "START" position for a few seconds to distribute oil.
- Replace with new spark plug(s).

### OTHER

- Do not store gasoline from one season to another.
- Replace your gasoline can if your can starts to rust. Rust and/or dirt in your gasoline will cause problems.
- If possible, store your tractor indoors and cover it to give protection from dust and dirt.
- Cover your tractor with a suitable protective cover that does not retain moisture. Do not use plastic. Plastic cannot breathe which allows condensation to form and will cause your tractor to rust.

**IMPORTANT:** NEVER COVER TRACTOR WHILE ENGINE AND EXHAUST ARE STILL WARM.

# TROUBLESHOOTING POINTS

PROBLEM	CAUSE	CORRECTION
Will not start	<ol style="list-style-type: none"> <li>1. Out of fuel.</li> <li>2. Engine not "CHOKED" properly.</li> <li>3. Engine flooded.</li> <li>4. Bad spark plug</li> <li>5. Dirty air filter</li> <li>6. Dirty fuel filter.</li> <li>7. Water in fuel</li>   <li>8. Loose or damaged wiring</li> <li>9. Carburetor out of adjustment</li>   <li>10. Engine valves out of adjustment.</li> </ol>	<ol style="list-style-type: none"> <li>1. Fill fuel tank</li> <li>2. See "TO START ENGINE" in Operation section.</li> <li>3. Wait several minutes before attempting to start.</li> <li>4. Replace spark plug</li> <li>5. Clean/replace air filter.</li> <li>6. Replace fuel filter.</li> <li>7. Drain fuel tank and carburetor. refill tank with fresh gasoline and replace fuel filter.</li> <li>8. Check all wiring.</li> <li>9. See "To Adjust Carburetor" in Service Adjustments section.</li> <li>10. Contact an authorized service center/department.</li> </ol>
Hard to start	<ol style="list-style-type: none"> <li>1. Dirty air filter.</li> <li>2. Bad spark plug.</li> <li>3. Weak or dead battery</li> <li>4. Dirty fuel filter.</li> <li>5. Stale or dirty fuel.</li> <li>6. Loose or damaged wiring.</li> <li>7. Carburetor out of adjustment</li>   <li>8. Engine valves out of adjustment.</li> </ol>	<ol style="list-style-type: none"> <li>1. Clean/replace air filter.</li> <li>2. Replace spark plug.</li> <li>3. Recharge or replace battery.</li> <li>4. Replace fuel filter.</li> <li>5. Drain fuel tank and refill with fresh gasoline.</li> <li>6. Check all wiring</li> <li>7. See "To Adjust Carburetor" in Service Adjustments section.</li> <li>8. Contact an authorized service center/department.</li> </ol>
Engine will not turn over	<ol style="list-style-type: none"> <li>1. Clutch/brake pedal not depressed</li> <li>2. Attachment clutch is engaged.</li> <li>3. Weak or dead battery.</li> <li>4. Blown fuse.</li> <li>5. Corroded battery terminals.</li> <li>6. Loose or damaged wiring</li> <li>7. Faulty ignition switch</li> <li>8. Faulty solenoid or starter</li> <li>9. Faulty operator presence switch(es).</li> </ol>	<ol style="list-style-type: none"> <li>1. Depress clutch/brake pedal</li> <li>2. Disengage attachment clutch.</li> <li>3. Recharge or replace battery.</li> <li>4. Replace fuse.</li> <li>5. Clean battery terminals</li> <li>6. Check all wiring.</li> <li>7. Check/replace ignition switch.</li> <li>8. Check/replace solenoid or starter.</li> <li>9. Contact an authorized service center/department.</li> </ol>
Engine clicks but will not start	<ol style="list-style-type: none"> <li>1. Weak or dead battery</li> <li>2. Corroded battery terminals.</li> <li>3. Loose or damaged wiring.</li> <li>4. Faulty solenoid or starter.</li> </ol>	<ol style="list-style-type: none"> <li>1. Recharge or replace battery.</li> <li>2. Clean battery terminals</li> <li>3. Check all wiring</li> <li>4. Check/replace solenoid or starter.</li> </ol>
Loss of power	<ol style="list-style-type: none"> <li>1. Cutting too much grass/too fast</li> <li>2. Throttle in "CHOKE" position.</li> <li>3. Build-up of grass, leaves and trash under mower.</li> <li>4. Dirty air filter.</li> <li>5. Low oil level/dirty oil.</li> <li>6. Faulty spark plug.</li> <li>7. Dirty fuel filter</li> <li>8. Stale or dirty fuel.</li> <li>9. Water in fuel.</li>   <li>10. Spark plug wire loose.</li> <li>11. Dirty engine air screen/fins.</li> <li>12. Dirty/clogged muffler.</li> <li>13. Loose or damaged wiring.</li> <li>14. Carburetor out of adjustment.</li>   <li>15. Engine valves out of adjustment.</li> </ol>	<ol style="list-style-type: none"> <li>1. Set in "Higher Cut" position/reduce speed</li> <li>2. Adjust throttle control</li> <li>3. Clean underside of mower housing</li> <li>4. Clean/replace air filter</li> <li>5. Check oil level/change oil.</li> <li>6. Clean and regap or change spark plug.</li> <li>7. Replace fuel filter</li> <li>8. Drain fuel tank and refill with fresh gasoline.</li> <li>9. Drain fuel tank and carburetor, refill tank with fresh gasoline and replace fuel filter.</li> <li>10. Connect and tighten spark plug wire</li> <li>11. Clean engine air screen/fins.</li> <li>12. Clean/replace muffler</li> <li>13. Check all wiring</li> <li>14. See "To Adjust Carburetor" in Service Adjustments section</li> <li>15. Contact an authorized service center/department.</li> </ol>
Excessive vibration	<ol style="list-style-type: none"> <li>1. Worn, bent or loose blade.</li> <li>2. Bent blade mandrel.</li> <li>3. Loose/damaged part(s).</li> </ol>	<ol style="list-style-type: none"> <li>1. Replace blade. Tighten blade bolt.</li> <li>2. Replace blade mandrel</li> <li>3. Tighten loose part(s) Replace damaged parts.</li> </ol>

# TROUBLESHOOTING POINTS

PROBLEM	CAUSE	CORRECTION
Engine continues to run when operator leaves seat with attachment clutch engaged	1. Faulty operator-safety presence control system	1. Check wiring, switches and connections. If not corrected, contact an authorized service center/department
Poor cut - uneven	1. Worn, bent or loose blade 2. Mower deck not level. 3. Buildup of grass, leaves, and trash under mower 4. Bent blade mandrel 5. Clogged mower deck vent holes from buildup of grass, leaves, and trash around mandrels	1. Replace blade Tighten blade bolt. 2. Level mower deck. 3. Clean underside of mower housing. 4. Replace blade mandrel 5. Clean around mandrels to open vent holes.
Mower blades will not rotate	1. Obstruction in clutch mechanism 2. Worn/damaged mower drive belt 3. Frozen idler pulley 4. Frozen blade mandrel	1. Remove obstruction 2. Replace mower drive belt 3. Replace idler pulley 4. Replace blade mandrel
Poor grass discharge	1. Engine speed too slow 2. Travel speed too fast 3. Wet grass 4. Mower deck not level 5. Low/uneven tire air pressure 6. Worn, bent or loose blade. 7. Buildup of grass, leaves and trash under mower 8. Mower drive belt worn 9. Blades improperly installed 10. Improper blades used 11. Clogged mower deck vent holes from buildup of grass, leaves, and trash around mandrels	1. Place throttle control in "FAST" position. 2. Shift to slower speed. 3. Allow grass to dry before mowing. 4. Level mower deck 5. Check tires for proper air pressure. 6. Replace/sharpen blade Tighten blade bolt. 7. Clean underside of mower housing. 8. Replace mower drive belt 9. Reinstall blades sharp edge down. 10. Replace with blades listed in this manual. 11. Clean around mandrels to open vent holes.
Headlight(s) not working (if so equipped)	1. Switch is "OFF" 2. Bulb(s) burned out. 3. Faulty light switch 4. Loose or damaged wiring 5. Blown fuse	1. Turn switch "ON" 2. Replace bulb(s) 3. Check/replace light switch 4. Check wiring and connections 5. Replace fuse
Battery will not charge	1. Bad battery cell(s) 2. Poor cable connections. 3. Faulty regulator (if so equipped) 4. Faulty alternator	1. Replace battery 2. Check/clean all connections 3. Replace regulator 4. Replace alternator
Engine "backfires" when turning engine "OFF"	1. Engine throttle control not set at "SLOW" position for 30 seconds before stopping engine.	1. Move throttle control to "SLOW" position and allow to idle for 30 seconds before stopping engine.