

SEARS

**OWNER'S
MANUAL**

**MODEL NO.
247.372650**

**Caution:
Read and Follow
All Safety Rules
and Instructions
Before Operating
This Equipment**

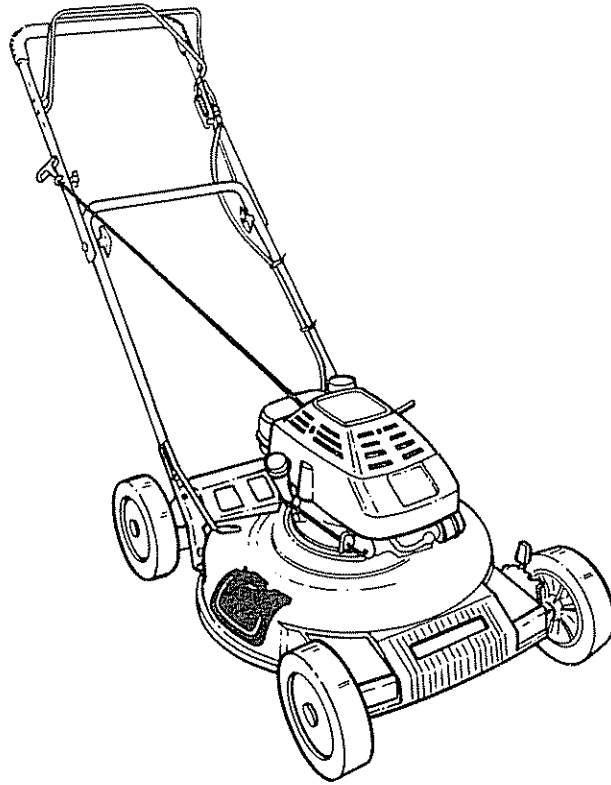

CRAFTSMAN®

**5.0 HORSEPOWER
21" POWER PROPELLED
5-SPEED "3-IN-1"
MULCHING ROTARY MOWER**

**Assembly
Operation
Maintenance
Service and Adjustment
Repair Parts**

SEARS, ROEBUCK AND CO., Hoffman Estates, IL 60179 U.S.A.

IMPORTANT

SAFE OPERATION PRACTICES



THIS SYMBOL POINTS OUT IMPORTANT SAFETY INSTRUCTIONS WHICH, IF NOT FOLLOWED, COULD ENDANGER THE PERSONAL SAFETY AND/OR PROPERTY OF YOURSELF AND OTHERS. READ AND FOLLOW ALL INSTRUCTIONS IN THIS MANUAL BEFORE ATTEMPTING TO OPERATE YOUR LAWN MOWER. FAILURE TO COMPLY WITH THESE INSTRUCTIONS MAY RESULT IN PERSONAL INJURY. WHEN YOU SEE THIS SYMBOL—  HEED ITS WARNING.



DANGER:

Your lawn mower was built to be operated according to the rules for safe operation in this manual. As with any type of power equipment, carelessness or error on the part of the operator can result in serious injury. If you violate any of these rules, you may cause serious injury to yourself or others.



TRAINING

- 1 Read this owner's guide carefully in its entirety before attempting to assemble or operate this machine. Be completely familiar with the controls and the proper use of this machine before operating it. Keep this manual in a safe place for future and regular reference and for ordering replacement parts.
- 2 Your rotary mower is a precision piece of power equipment, not a plaything. Therefore, exercise extreme caution at all times. Your unit has been designed to perform one job: to mow grass. Do not use it for any other purpose.
- 3 Never allow children under 14 years old to operate a power mower. Children 14 years old and over should only operate mower under close parental supervision. Only persons well acquainted with these rules of safe operation should be allowed to use your mower.
- 4 Keep the area of operation clear of all persons, particularly small children and pets. Stop engine when they are in the vicinity of your mower to help prevent blade contact or thrown object injury. Although the area of operation should be completely cleared of foreign objects, an object may have been overlooked and could be accidentally thrown by the mower in any direction and cause serious personal injury to the operator or any others allowed in the area.



PREPARATION

- 1 Thoroughly inspect the area where the equipment is to be used. Remove all stones, sticks, wire, bones and other foreign objects which could be picked up and thrown by the mower in any direction and cause serious personal injury to the operator or any others allowed in the area. Plan your mowing pattern to avoid discharge of material toward roads, sidewalks, bystanders and the like.
- 2 Always wear safety glasses or eye shields during operation or while performing an adjustment or repair, to protect eyes from foreign objects that may be thrown from the machine in any direction.
- 3 Wear sturdy, rough-soled work shoes and close-fitting slacks and shirts. Shirts and pants that cover the arms and legs and steel-toed shoes are recommended. Do not wear loose fitting clothes or jewelry. They can be caught in moving parts. Never operate a unit in bare feet, sandals, or sneakers.
- 4 Before working with gasoline, extinguish all cigarettes, cigars, pipes and other sources of ignition. Check the fuel level before starting the engine. Gasoline is an extremely flammable fuel. Do not fill the gasoline tank indoors, while the engine is running, or until engine has been allowed to cool for at least two minutes after running. Replace gasoline cap securely and wipe off any spilled gasoline before starting the engine as it may cause a fire or explosion.
- 5 Disengage the self-propelled mechanism or drive clutch on units so equipped before starting the engine.
- 6 The blade control handle is a safety device. Never attempt to bypass its operation. Doing so makes the safety device inoperative and may result in personal injury through contact with the rotating blade. The blade control handle must operate easily in both directions and automatically return to the disengaged position when released.
- 7 Never attempt to make a wheel or cutting height adjustment while the engine is running.

- 8 Never operate the mower in wet grass. Always be sure of your footing. A slip and fall can cause serious personal injury. Keep a firm hold on the handle and walk, never run. Mow only in daylight or in good artificial light.
- 9 For your safety, use the slope gauge included as part of this manual to measure slopes before operating this unit on a sloped or hilly area. If the slope is greater than 15° as shown on the slope gauge, do not operate this unit on that area or serious injury could result.



OPERATION

- 1 Do not change the engine governor settings or overspeed the engine. Excessive engine speeds are dangerous.
- 2 Do not put hands or feet near or under rotating parts. Keep clear of the discharge opening at all times as the rotating blade can cause injury.
- 3 Stop the blade when crossing gravel drives, walks or roads.
- 4 After striking a foreign object, stop the engine, remove the wire from the spark plug, and thoroughly inspect the mower for any damage. Repair the damage before restarting and operating the mower.
- 5 If the equipment should start to vibrate abnormally, stop the engine and check immediately for the cause. Vibration is generally a warning of trouble.
- 6 Shut the engine off and wait until the blade comes to a complete stop before removing the grass catcher or unclogging the chute. The cutting blade continues to rotate for a few seconds after the engine is shut off. Never place any part of the body in the blade area until you are sure the blade has stopped rotating.
- 7 Before cleaning, repairing or inspecting, make certain the blade and all moving parts have stopped. Disconnect the spark plug wire, and keep the wire away from the spark plug to prevent accidental starting.
- 8 Do not run the engine indoors.
- 9 Never cut grass by pulling mower toward you. Mow across the face of slopes, never up-and-down. Exercise extreme caution when changing direction on slopes. Do not mow excessively steep slopes. Always be sure of your footing. A slip and fall can cause serious personal injury.
- 10 Never operate mower without proper guards, plates or other safety protective devices in place.
- 11 Muffler and engine become hot and can cause a burn. Do not touch.



MAINTENANCE AND STORAGE

- 1 Check the blade and engine mounting bolts at frequent intervals for proper tightness. Also visually inspect blade for damage (e.g. bent, cracked). Replace with blade which meets original equipment specifications.
- 2 Keep all nuts, bolts, and screws tight to be sure the equipment is in safe working condition.
- 3 Never store the mower with gasoline in the tank or gas containers inside of a building where fumes may reach an open flame or spark (e.g. gas hot water heater). Allow the engine to cool before storing in any enclosure.
- 4 To reduce fire hazard, keep the engine free of grass, leaves and excessive oil.
- 5 Check the grass catcher bag frequently for wear or deterioration. Replace a worn or damaged bag immediately. For safety protection, replace only with new bag meeting original equipment specifications.

IMPORTANT: FEDERAL REGULATIONS REQUIRE OPERATOR PRESENCE BLADE STOP CONTROLS TO MINIMIZE THE RISK OF BLADE CONTACT INJURY. YOUR LAWN MOWER IS EQUIPPED WITH SUCH CONTROLS. DO NOT ATTEMPT TO DEFEAT THE FUNCTION OF THE OPERATOR PRESENCE CONTROL UNDER ANY CIRCUMSTANCES.

CONGRATULATIONS on your purchase of a Sears Craftsman Lawn Mower. It has been designed, engineered and manufactured to give you the best possible dependability and performance.

Should you experience any problem you cannot easily remedy, please return the lawn mower to the nearest Sears Service Center/Department in the United States. We have competent, well-trained technicians and the proper tools to service or repair this unit.

Please read and retain this manual. The instructions will enable you to assemble and maintain your lawn mower properly. Always observe the "SAFETY RULES."

MODEL NUMBER **247.372650**

SERIAL NUMBER _____

DATE OF PURCHASE _____

THE MODEL AND SERIAL NUMBERS WILL BE FOUND ON A LABEL ATTACHED TO THE TOP REAR OF THE DECK.

YOU SHOULD RECORD BOTH SERIAL NUMBER AND DATE OF PURCHASE AND KEEP IN A SAFE PLACE FOR FUTURE REFERENCE.

CUSTOMER RESPONSIBILITIES

- Read and observe the safety rules.
- Follow a regular schedule in maintaining, caring for and using your lawn mower.
- Follow the instructions under "Customer Responsibilities" and "Storage" sections of this Owner's Manual.

TWO YEAR LIMITED WARRANTY ON CRAFTSMAN LAWN MOWER

For two years from the date of purchase, when this Craftsman Lawn Mower is maintained and lubricated according to the instructions in the owner's manual, Sears will repair, free of charge, any defect in material and workmanship.

If this Craftsman Lawn Mower is used for commercial purposes, this warranty applies for only 90 days from the date of purchase.

This warranty does not cover:

- Expendable items which become worn during normal use, such as blades, blade adapters, belts, air cleaners and spark plugs.
- Repairs necessary because of operator abuse or negligence, including bent crankshafts and the failure to maintain the equipment according to the instructions contained in the owner's manual.

WARRANTY SERVICE IS AVAILABLE BY RETURNING THE CRAFTSMAN LAWN MOWER TO THE NEAREST SEARS SERVICE CENTER/DEPARTMENT IN THE UNITED STATES. THIS WARRANTY APPLIES ONLY WHILE THIS PRODUCT IS IN USE IN THE UNITED STATES.

This warranty gives you specific legal rights, and you may also have other rights which may vary from state to state.

SEARS, ROEBUCK AND CO., D/817WA, Hoffman Estates, IL 60179

PRODUCT SPECIFICATIONS

Horsepower:	5.0
Displacement:	12.04 cu. in.
Fuel Capacity:	1 Quart (Unleaded)
Oil (20 ounces): API Classification SG	SAE 30
Spark Plug (Gap .030 in.):	Champion J19LM (or Equivalent)
Blade Bolt Torque:	450-600 in. lbs.

MAINTENANCE AGREEMENT

A Sears Maintenance Agreement is available on this product. Contact your nearest Sears store for details.

WARNING: This unit is equipped with an internal combustion engine and should not be used on or near any unimproved forest-covered, brush-covered or grass-covered land unless the engine's exhaust system is equipped with a spark arrester meeting applicable local or state laws (if any). If a spark arrester is used, it should be maintained in effective working order by the operator.

In the State of California the above is required by law (Section 4442 of the California Public Resources Code). Other states may have similar laws. Federal laws apply on federal lands. A spark arrester for the muffler is available through your nearest Sears Authorized Service Center (See the REPAIR PARTS section of this manual.)

TABLE OF CONTENTS

SAFETY RULES	2	SERVICE AND ADJUSTMENT	12, 13
PRODUCT SPECIFICATIONS	3	STORAGE	14
WARRANTY	3	TROUBLE SHOOTING	15
INDEX	4	REPAIR PARTS—MOWER	16-18
MOWER ACCESSORIES	4	REPAIR PARTS—ENGINE	19-22
ASSEMBLY	5, 6	SLOPE GAUGE	23
OPERATION	6-9	PARTS ORDERING/SERVICE	BACK PAGE
CUSTOMER RESPONSIBILITIES	9-11		

INDEX

<p style="text-align: center;">A</p> <p>Accessories 4</p> <p>Adjustments:</p> <p style="padding-left: 20px;">Carburetor 12</p> <p style="padding-left: 20px;">Cutting Height 7</p> <p style="padding-left: 20px;">Engine Speed 12</p> <p style="padding-left: 20px;">Handle Height 11</p> <p>Air Filter 10</p> <p>Assembly 5, 6</p> <p style="text-align: center;">B</p> <p>Belt Removal and Replacement 13, 14</p> <p>Blade:</p> <p style="padding-left: 20px;">Replacement 10</p> <p style="padding-left: 20px;">Sharpening 10</p> <p style="text-align: center;">C</p> <p>Controls:</p> <p style="padding-left: 20px;">Blade Control Handle 7</p> <p style="padding-left: 20px;">Engine Speed Control 7</p> <p>Cleaning 11</p> <p>Customer Responsibilities 9</p> <p>Cutting Height 7</p> <p style="text-align: center;">D</p> <p>Deflector, Side Discharge 6</p> <p>Drive Clutch Adjustment 12</p> <p style="text-align: center;">E</p> <p>Engine:</p> <p style="padding-left: 20px;">Lubrication 10</p> <p style="padding-left: 20px;">Speed Control 7</p> <p style="padding-left: 20px;">Starting 8</p> <p style="padding-left: 20px;">Storage 14</p> <p style="text-align: center;">F</p> <p>Filter, Air 11</p>	<p style="text-align: center;">G</p> <p>Gasoline:</p> <p style="padding-left: 20px;">Storage 14</p> <p style="padding-left: 20px;">Tank Capacity 7</p> <p style="padding-left: 20px;">Type 7</p> <p style="text-align: center;">H</p> <p>Handle:</p> <p style="padding-left: 20px;">Height Adjustment 11</p> <p style="padding-left: 20px;">Storage 14</p> <p style="text-align: center;">L</p> <p>Lubrication:</p> <p style="padding-left: 20px;">Brake Spring Bracket 9</p> <p style="padding-left: 20px;">Engine 10</p> <p style="padding-left: 20px;">Wheel Adjusters 9</p> <p style="padding-left: 20px;">Wheels 9</p> <p style="text-align: center;">M</p> <p>Maintenance:</p> <p style="padding-left: 20px;">Agreement 3</p> <p style="padding-left: 20px;">Air Filter 10</p> <p style="padding-left: 20px;">Blade Care/Replacement 10</p> <p style="padding-left: 20px;">Engine 10</p> <p style="padding-left: 20px;">Lubrication 9</p> <p style="padding-left: 20px;">Spark Plug 10</p> <p style="padding-left: 20px;">Schedule 9</p> <p style="padding-left: 20px;">Mulching and Mowing Tips 8</p> <p style="padding-left: 20px;">Mulching Plug 6</p> <p style="text-align: center;">O</p> <p>Oil:</p> <p style="padding-left: 20px;">Change 10</p> <p style="padding-left: 20px;">Storage 14</p> <p style="padding-left: 20px;">Type 9</p> <p style="padding-left: 20px;">Operating Mower 6, 7, 8</p>	<p style="text-align: center;">P</p> <p>Primer 8, 10</p> <p style="text-align: center;">R</p> <p>Repair/Replacement Parts 16-22</p> <p>Responsibilities, Customer 9-11</p> <p>Rope Guide 7</p> <p style="text-align: center;">S</p> <p>Safety Rules 2</p> <p>Service and Adjustments:</p> <p style="padding-left: 20px;">Blade 10</p> <p style="padding-left: 20px;">Carburetor 12</p> <p style="padding-left: 20px;">Cutting Height 7</p> <p style="padding-left: 20px;">Engine 11</p> <p style="padding-left: 20px;">Handle Height 11</p> <p style="padding-left: 20px;">Rear Trail Shield 12</p> <p style="padding-left: 20px;">Service Recommendations 9</p> <p style="padding-left: 20px;">Side Discharge Deflector 6</p> <p style="padding-left: 20px;">Spark Plug 10</p> <p style="padding-left: 20px;">Specifications 3</p> <p style="padding-left: 20px;">Starting the Engine 8</p> <p style="padding-left: 20px;">Stopping the Mower 10</p> <p style="padding-left: 20px;">Storage 14</p> <p style="text-align: center;">T</p> <p>Table of Contents 4</p> <p>Trouble Shooting Guide 15</p> <p style="text-align: center;">W</p> <p>Warranty 3</p> <p>Wheels:</p> <p style="padding-left: 20px;">Adjusting Height 7</p> <p style="padding-left: 20px;">Lubrication 9</p>
------------------------------------------------------------------------------------------------------------------------------------------------------------------------------------------------------------------------------------------------------------------------------------------------------------------------------------------------------------------------------------------------------------------------------------------------------------------------------------------------------------------------------------------------------------------------------------------------------------------------------------------------------------------------------------------------------------------------------------------------------------------------------------------------------------------------------------------------------------------------------------------------------------------------------------------------------------------------------------------------------------------------------------------------------------------------------------------------------------------------------------------------------------------------------------------------------------------------------------------------------------------------------------------------------------------------------------------------------------------------------------------------------	-----------------------------------------------------------------------------------------------------------------------------------------------------------------------------------------------------------------------------------------------------------------------------------------------------------------------------------------------------------------------------------------------------------------------------------------------------------------------------------------------------------------------------------------------------------------------------------------------------------------------------------------------------------------------------------------------------------------------------------------------------------------------------------------------------------------------------------------------------------------------------------------------------------------------------------------------------------------------------------------------------------------------------------------------------------------------------------------------------------------------------------------------------------------------------------------------------------------------------------------------------------------------------------------------------------------------------------------------------------------------------------------------------------------------------------------------------------------------------------------------------------------------------------------------------------------------------------------	----------------------------------------------------------------------------------------------------------------------------------------------------------------------------------------------------------------------------------------------------------------------------------------------------------------------------------------------------------------------------------------------------------------------------------------------------------------------------------------------------------------------------------------------------------------------------------------------------------------------------------------------------------------------------------------------------------------------------------------------------------------------------------------------------------------------------------------------------------------------------------------------------------------------------------------------------------------------------------------------------------------------------------------------------------------------------------------------------------------------------------------------------------------------------------------------------------------------------------------------------------------------------------------------------------------------------------------------------------------------------------------------------------------------------------------------------------------

MOWER ACCESSORIES

These accessories were available when the mower was purchased. They are also available at most Sears retail outlets, catalog and service centers. Most Sears stores can order repair parts for you, when you provide the model number of your mower.

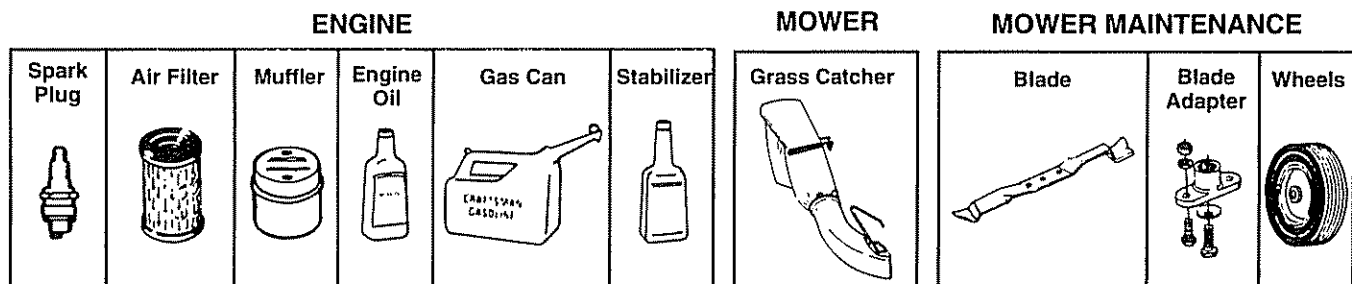

ASSEMBLY

IMPORTANT: This unit is shipped **WITHOUT GASOLINE** or **OIL** in the engine. Be certain to service engine with gasoline and oil before operating your mower.

NOTE: Reference to right or left hand side of the mower is observed from the operating position.

TO REMOVE MOWER FROM CARTON

- Remove the carton inserts (if any). Remove the owner's manual, side discharge chute and bottle of oil which are in the carton. Lift the mower from the carton, or cut the corners of the carton and roll the mower out.

NOTE: A grass catcher bracket is in the bag with the owner's manual. Keep this bracket in a safe place. If you purchase the optional grass catcher, mount the bracket on the right side of the upper handle as shown on page 16 of this manual, key 10.

HOW TO SET-UP YOUR LAWN MOWER

- Disconnect the spark plug wire from the spark plug. Ground the spark plug wire by attaching it to the retaining post until ready to operate your mower. See figures 1 and 2. (Spark plug wire is shown in figure 1 without the rubber boot for clarity.)
- Remove any cardboard pieces which may be between the upper and lower handles for shipping purposes.
- Pull up and back on the upper handle to raise the handle into the operating position. Make certain the lower handle is seated securely into the handle mounting brackets. Tighten the hand knobs on each side of the handle.

NOTE: Your mower is shipped with the handle in the higher height position. If you wish to lower the height of the handle, refer to the Adjustment Section at this time.

- Remove the hairpin clips from the outer hole in the weld pins on the handle mounting brackets. Place the hairpin clips in the **inner** hole. See figure 3.
- The rope guide and wing nut are attached to the starter rope, on top of the engine. Remove the wing nut from rope guide. Remove the rope guide from the starter rope.
- With the spark plug wire disconnected and grounded, hold the blade control handle against the upper handle, and pull the starter rope out of the engine. Hold the rope guide as shown so the opening in the rope guide is toward the front of mower. Slip the rope guide around the starter rope and into the right side of upper handle using the hole shown. Secure using the wing nut. See figure 4.
- Make certain all nuts and bolts are tightened securely. Also, be certain to reconnect the spark plug wire before starting the mower.

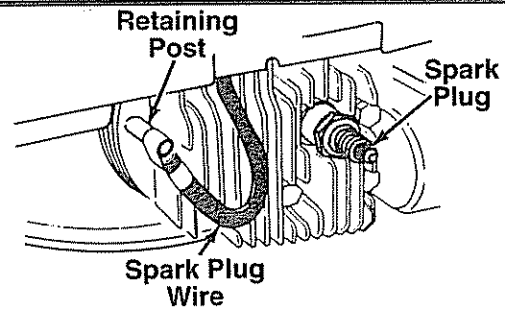

FIGURE 1.

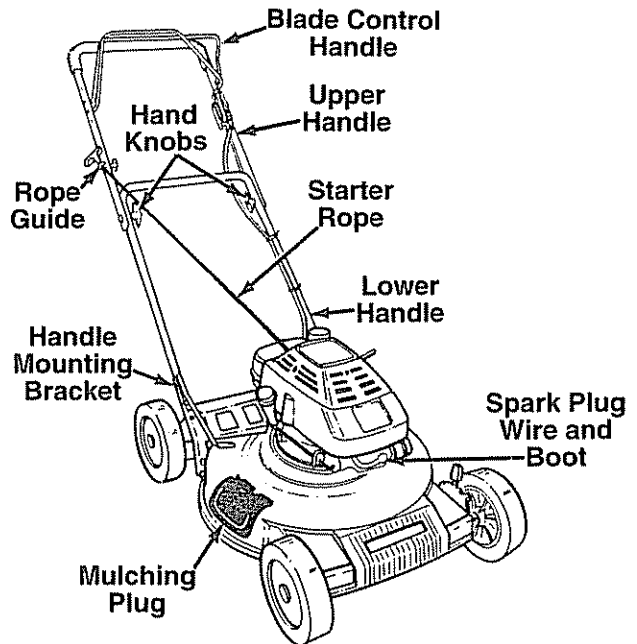

FIGURE 2.

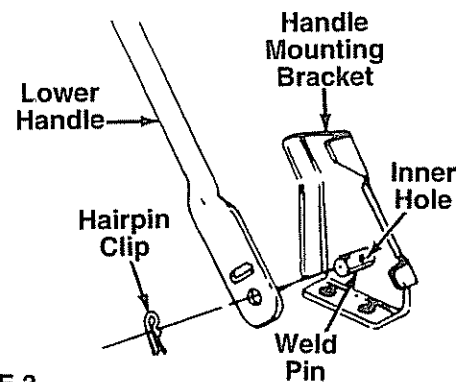

FIGURE 3.

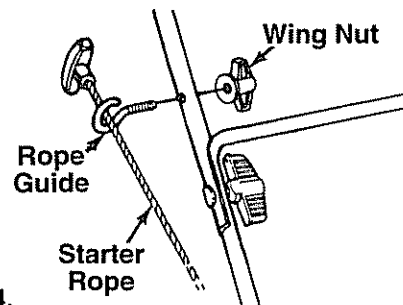

FIGURE 4.

Your mower has been shipped as a mulcher. To discharge grass to the side, proceed as follows.

- **To convert your mower from a mulcher to a side discharge mower**, lift the mulching plug. See figure 5. Slide the two hooks on the side discharge deflector under the hinge pin on the mulching plug assembly. Lower the mulching plug.

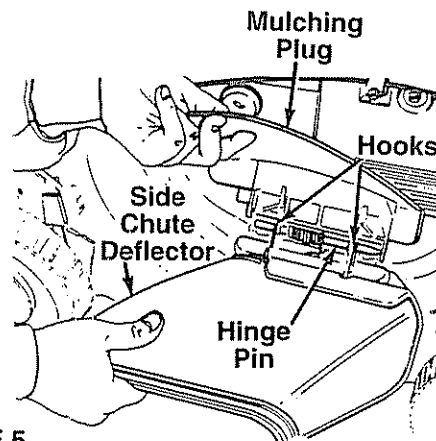

FIGURE 5.

OPERATION

KNOW YOUR LAWN MOWER

READ THIS OWNER'S MANUAL AND SAFETY RULES BEFORE OPERATING YOUR LAWN MOWER. Compare the illustrations with your lawn mower to familiarize yourself with the location of various controls and adjustments. Save this manual for future reference.

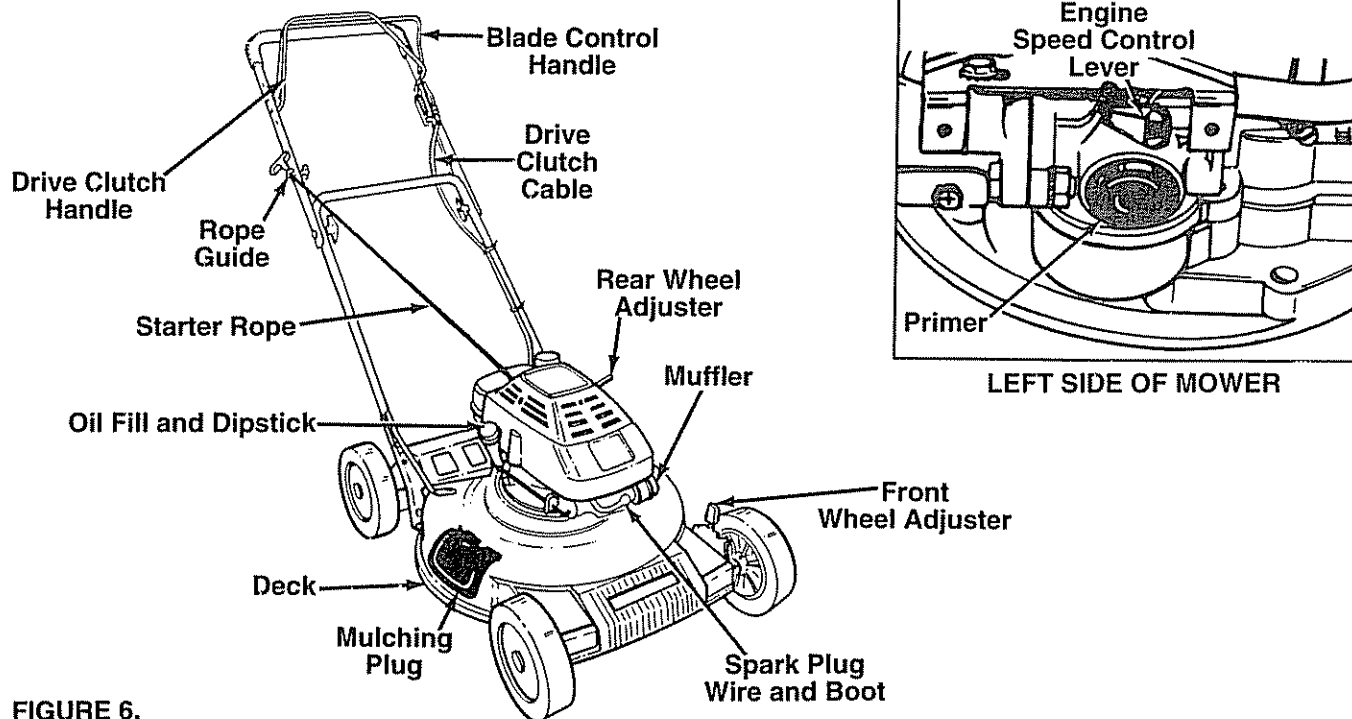

FIGURE 6.

MEETS CPSC BLADE SAFETY REQUIREMENTS

Sears Walk-Behind Lawn Mowers conform to the safety standards of the American National Standards Institute, and the U.S. Consumer Product Safety Commission. The blade turns when the engine is running.

BLADE CONTROL HANDLE—must be held down to the handle to start and run the engine. Release to stop the engine.

STARTER ROPE—used for starting the engine.

PRIMER—pumps additional fuel from the carburetor to the cylinder for use when starting a cold engine.

ENGINE SPEED CONTROL LEVER—permits selection of fast or slow engine speed.

DRIVE CLUTCH CONTROL—must be held against the handle to engage the wheel drive. Release the drive clutch control to stop the wheels from driving.

SHIFT LEVER—is used to select one of five operating speeds for the mower.

OPERATION

BEFORE USING YOUR LAWN MOWER, AGAIN REFER TO THE "SAFETY RULES" AS SHOWN ON PAGE 2 OF THIS MANUAL. ALWAYS BE CAREFUL.



The operation of any lawn mower can result in foreign objects being thrown into the eyes, which can result in severe eye damage. Always wear safety glasses or eye shields before starting power tool operation or while performing any adjustments or repairs. We recommend Wide Vision Safety Mask for over spectacles or standard glasses available at Sears Retail or Catalog Stores.

HOW TO USE YOUR MOWER

TO STOP ENGINE

Release blade control handle to stop engine. Disconnect the spark plug wire and move it away from the spark plug to prevent accidental starting while equipment is unattended.

ENGINE SPEED CONTROL

The engine speed is controlled by a lever (red knob) located on the left side of the engine. The "HI" position is for starting engine, normal cutting and best performance. The "LOW" position is for light cutting, trimming and fuel economy.

BLADE CONTROL HANDLE

Your mower has a control handle which requires the operator to be behind the handle to start and run the mower. When the operator releases the control handle, the engine will stop and an internal brake helps the blade to stop quickly.

When the operator leaves the operating position to change the cutting height, pick up sticks or other objects in the way, the engine will stop automatically when the control handle is released.

DRIVE CLUTCH CONTROL

To engage the wheel drive, hold the drive clutch control against the handle. Releasing the drive clutch control stops the wheels from driving. Release the drive clutch control to slow down when negotiating an obstacle, making a turn or stopping.

SHIFT LEVER

The five speed shift lever is located on the left side of the mower, beside the engine. See figure 7. To select the mower speed, depress the lever, move to desired position and release the lever. Position 1 is the slowest speed; position 5 is the fastest.



WARNING: TO AVOID PERSONAL INJURY, DO NOT MOVE THE SHIFT LEVER WHEN THE ENGINE IS RUNNING.

ADJUST CUTTING HEIGHT

Each wheel has an adjuster lever to set the cutting height on your mower. They should always be set to the same position.

- Raise wheels for low cut and lower wheels for high cut.

- To change cutting height, move adjuster levers toward wheels. See figure 7. Move wheels up or down to suit your requirements. Be sure all four levers are in the same setting.
- Adjust cutting height to suit your requirements. Refer to the "Mulching or Mowing Tips" on page 9. (The height adjusters may seem hard to move when new. They will operate easier after some use.)

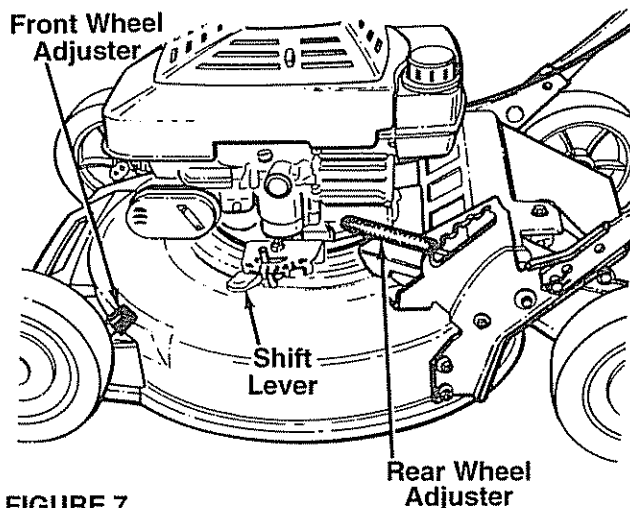

FIGURE 7.

BEFORE STARTING ENGINE

OIL

A 20 ounce bottle of SAE 30 oil is included with your new lawn mower.

Only use high quality detergent oil rated with API service classification SG. Select the oil's viscosity grade according to your expected operating temperature.

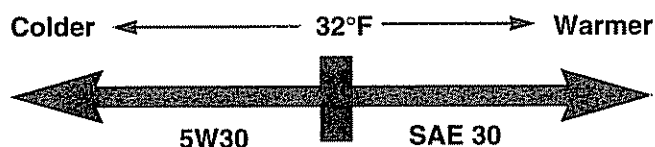

NOTE: Although multi-viscosity oil (5W30, 10W30, etc.) improve starting in cold weather, these multi-viscosity oils will result in increased oil consumption when used above 32°F. Check your oil level more frequently to avoid possible engine damage from running low on oil.

OPERATION

- Place unit so engine is in a level position.
- Remove oil fill cap and dipstick assembly. Pour oil slowly until oil level is to the FULL mark on dipstick. Crankcase capacity is approximately 1-1/4 pints (20 ounces). DO NOT OVERFILL.

NOTE: Crankcase oil should be changed after first two (2) hours of operation and every twenty-five (25) hours thereafter. Refer to ENGINE LUBRICATION section.

- Replace oil fill cap and dipstick. Tighten cap securely.

GAS

- Fill gas tank with about one (1) quart of clean, fresh, lead-free grade automotive gasoline. Low-lead or regular gasoline is an acceptable substitute. DO NOT use Ethyl or high octane gasoline. Be certain container is clean and free from rust or foreign particles. Never use gasoline that may be stale from long periods of storage in the container.

WARNING: EXPERIENCE INDICATES THAT ALCOHOL BLENDED FUELS (CALLED GASOHOL OR USING ETHANOL OR METHANOL) CAN ATTRACT MOISTURE WHICH LEADS TO SEPARATION AND FORMATION OF ACIDS DURING STORAGE. ACIDIC GAS CAN DAMAGE THE FUEL SYSTEM OF AN ENGINE WHILE IN STORAGE. TO AVOID ENGINE PROBLEMS, THE FUEL SYSTEM SHOULD BE EMPTIED BEFORE STORAGE FOR 30 DAYS OR LONGER. USE FRESH FUEL NEXT SEASON. SEE "STORAGE" SECTION FOR ADDITIONAL INFORMATION.

NEVER USE ENGINE OR CARBURETOR CLEANER PRODUCTS IN THE FUEL TANK OR PERMANENT DAMAGE MAY OCCUR.

TO START ENGINE



WARNING: WHEN STARTING THE UNIT FOR THE FIRST TIME, PLACE MOWER IN FIRST SPEED (SLOW) POSITION. FACE THE MOWER AGAINST A SOLID OBJECT SUCH AS A WALL, FENCE, ETC. START THE UNIT, AND IF IT SHOWS ANY SIGNS OF MOTION WITH THE DRIVE CLUTCH CONTROL DISENGAGED, SHUT THE ENGINE OFF IMMEDIATELY. ADJUST THE DRIVE CLUTCH CONTROL AS INSTRUCTED IN THE ADJUSTMENT SECTION.

NOTE: The drive cable has been adjusted at the factory with the unit in third speed. If the drive slips when mower is operated in first speed, tighten the cable by moving the adjustment wheel toward the inside of the mower slightly as shown in figure 14 (Adjustment section).

In addition, the drive clutch may need to be loosened when the unit is operated in fifth speed. ALWAYS MAKE CERTAIN THE MOWER DOES NOT DRIVE WITH THE DRIVE CLUTCH CONTROL HANDLE RELEASED. Refer to "Drive Clutch Adjustment" for further information.

- Connect spark plug wire to spark plug. Make certain the metal loop on the end of the spark plug wire (inside the rubber boot) is fastened securely over the metal tip on the spark plug. See figure 8.

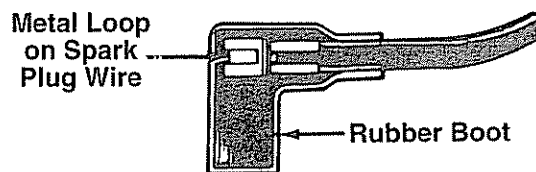

FIGURE 8.

- Press primer button as follows (cold starts only).
For each initial start, push primer button five times prior to starter operation. See figure 9. Use sharp pushes, wait between each push. Repeat the above for each starter operation as necessary. **Do not use primer for warm engine restarts.**
- Set engine speed control to "HI" speed.

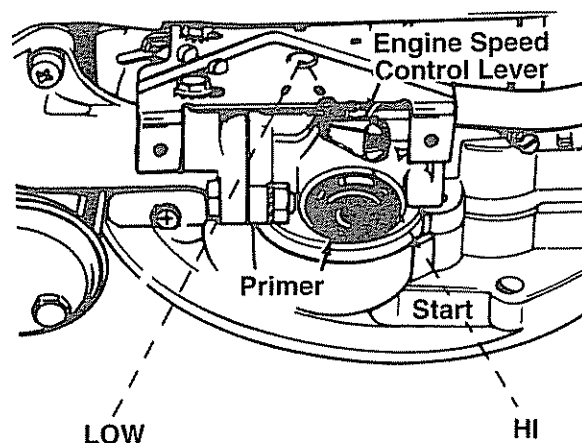

FIGURE 9.

- Hold blade control handle against upper handle. See figure 10. Grasp starter handle and pull rope out slowly until engine reaches start of compression cycle (rope will pull slightly harder at this point). Let the rope rewind slowly.
- Pull rope with a rapid, continuous, full arm stroke. Keep a firm grip on start handle. Let rope rewind slowly. Do not let starter handle snap back against starter.
- If after three pulls the engine fails to start, push primer five times, then pull starter rope again.

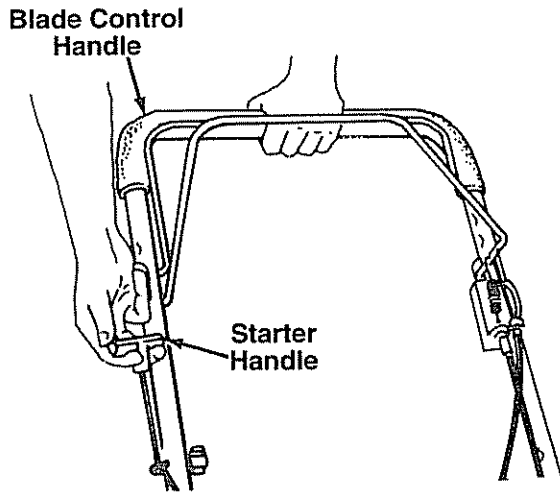

FIGURE 10.

MULCHING OR MOWING TIPS

- For best results in normal and heavy mowing, always run engine in "HI" speed position. "LOW" speed is only for light cutting, trimming and fuel economy.
- The grass condition at the time of mowing determines the proper mower cutting height setting for best lawn appearance. For a healthy lawn, always cut one-third or less of the total length of the grass at any one cutting.
- Under certain conditions, such as very tall grass, it may be necessary to raise the height of cut to reduce pushing effort and to keep from overloading the engine and leaving clumps of grass clippings.
- For extremely heavy cutting, use a slow ground speed, and reduce the width of cut.
- Under heavy conditions cross cut for additional mulching of surface debris.

CUSTOMER RESPONSIBILITIES

GENERAL RECOMMENDATIONS

- In order to maintain the warranty on your mower, the customer is expected to perform the maintenance as outlined below.
- Once a year you should replace the spark plug, air filter, and check blade for wear. A new spark plug and air filter assures proper air-fuel mixture and helps your engine run better and last longer.

MAINTENANCE SCHEDULE

SERVICE RECORD	SCHEDULE			SERVICE DATES					
	Every Use	After First Two Hours	Every 25 Hours						
Fill in dates as you complete regular service									
Check Engine Oil	√								
Lubricate Mower			√						
Blade Care			√						
Change Engine Oil		√	√						
Spark Plug Replaced			√						
Air Filter Replaced			√						
Cleaning	√								

√ CHECK

CUSTOMER RESPONSIBILITIES

LUBRICATION

ENGINE OIL RECOMMENDATIONS

A 20 ounce bottle of SAE 30 oil is included with your new lawn mower.

Only use high quality detergent oil rated with API service classification SG. Select the oil's viscosity grade according to your expected operating temperature.

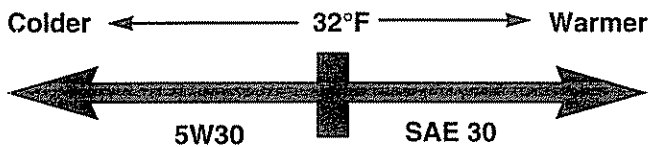

NOTE: Although multi-viscosity oil (5E30, 10W30, etc.) improves starting in cold weather, these multi-viscosity oils will result in increased oil consumption when used above 32° F. Check your oil level more frequently to avoid possible engine damage from running low on oil.

WHEELS

DO NOT oil or grease the wheel bearings. Viscous lubricants will attract dust and dirt that will shorten the life of the self-lubricating wheel bearings. If you feel the wheels must be lubricated, use only a dry, silicone type lubricant sparingly.

WHEEL ADJUSTERS

For easy operation, lubricate the wheel adjusters at least once a season with light oil.

BRAKE SPRING BRACKET

Spray a light oil lubricant on the brake spring bracket, located on the right rear corner of the engine, at least once a season.

TRANSMISSION

The transmission is pre-lubricated and sealed at the factory. It does not require checking. If disassembled for any reason, fill with 2 ounces of Alvania grease, part number 737-0168.

MOWER

BLADE CARE

Your mower will work better with a sharp blade.



CAUTION: DISCONNECT SPARK PLUG WIRE FROM SPARK PLUG AND PLACE WIRE WHERE IT CANNOT COME IN CONTACT WITH THE SPARK PLUG.

TO REMOVE BLADE (See Figure 11):

- Turn mower on its side. Make sure air filter and carburetor are up.

- Use a block of wood between blade and mower deck to prevent blade from turning when bolt is removed. Protect your hands with gloves and/or wrap blade with heavy cloth.

- Remove blade bolt by turning counterclockwise. Use a 9/16" box or open-end wrench.

TO REPLACE BLADE (See Figure 11):

- Put blade adapter on engine crankshaft.
- Fit blade in adapter. Be sure trailing edge of blade is up towards engine.
- Assemble bolts, washers, and nuts in the exact order of removal.
- Use block of wood to hold blade and tighten bolt clockwise. The recommended torque for the center is 450-600 in. lbs. The recommended torque for the blade adapter bolts is 200-350 in. lbs. Torque wrenches are available at most Sears stores and through the catalog.

IMPORTANT: THE BOLT USED TO SECURE THE BLADE TO ENGINE IS SPECIALLY HEAT-TREATED. DO NOT SUBSTITUTE (SEE REPAIR PARTS).



CAUTION: A LOOSE BLADE CAN BE DANGEROUS AND MAY MAKE THE ENGINE HARD TO START.

Use only a Sears authorized replacement blade to get the best cutting results.

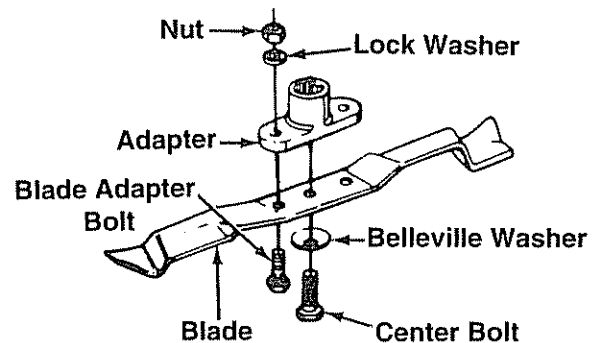

FIGURE 11.

NOTE: We do not recommend sharpening the blade—but if you do, be sure blade is balanced.

TO SHARPEN BLADE

- The blade can be sharpened with a file or on a grinding wheel. Do not attempt to sharpen while on the mower.
- Care should be taken to keep the blade balanced. An unbalanced blade will cause excessive vibration when running and eventual damage to mower and engine.

CUSTOMER RESPONSIBILITIES

- To check blade balance, drive a nail into a beam or wall. Leave about one inch of the straight nail exposed. Place center hole of blade over the head of the nail. If blade is balanced, it should remain in a horizontal position. If either end of the blade moves downward, blade is not balanced. Sharpen the heavy end until the blade is balanced.

ENGINE

ENGINE LUBRICATION

You must change the oil in the crankcase after the first two (2) hours of operation and after each 25 hours of use thereafter. **CHANGE THE OIL MORE FREQUENTLY IF USED IN SANDY OR DUSTY CONDITIONS.**

TO DRAIN OIL

- Disconnect spark plug wire from spark plug and place wire where it cannot come in contact with plug.
- Drain the gas tank.
- Remove the oil fill cap and dipstick. Turn and tip the unit on its side with the carburetor up, and drain oil into a suitable container.
- Refill crankcase with oil. Refer to "ENGINE OIL RECOMMENDATIONS" on previous page.
- Replace oil fill cap and dipstick. Tighten cap securely.

SPARK PLUG

Change your spark plug each year to make your engine start easier and run better. Set spark plug gap at .030 inch.

AIR FILTER

Your engine will not run properly and may be damaged by using a dirty air filter.

Replace the air filter every year, more often if you mow in very dusty, dirty conditions. Do not wash air filter.

TO CHANGE AIR FILTER (See Figure 12):

- Remove the air filter cover by turning counterclockwise to the stop and pull away from collar.
- Remove filter from inside of cover.

- Clean the inside of the cover and the collar with a clean cloth to remove any dirt accumulation.
- Insert new filter into cover.
- Put air filter cover and filter into collar aligning the tab with the slot.
- Push in on cover and turn clockwise to tighten.

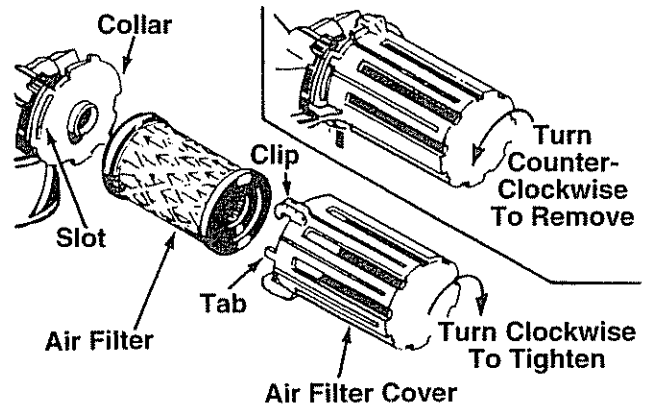

FIGURE 12.

CLEANING



WARNING: DISCONNECT SPARK PLUG WIRE FROM SPARK PLUG AND PLACE WIRE WHERE IT CANNOT COME IN CONTACT WITH THE SPARK PLUG.

- Turn mower on its side with carburetor and air filter up.
- Clean the underside of your mower after each use by scraping to remove build-up of grass clippings, leaves, dirt or other matter. If this debris is allowed to accumulate, it will invite rust and corrosion, and may prevent proper mulching.
- Clean your mower and engine often to keep build-up of grass or debris from accumulating around engine. A clogged engine runs hotter and shortens engine life.

NOTE: We DO NOT recommend using a garden hose to clean mower unless the electrical system, muffler, air filter and carburetor are covered to keep water out. Water in engine can result in shortening engine life.

SERVICE AND ADJUSTMENT

CUTTING HEIGHT ADJUSTMENT

Refer to "ADJUST CUTTING HEIGHT" in operation section of manual.

HANDLE HEIGHT ADJUSTMENT

Your mower is shipped with the handle in the higher height position. To lower the handle height, proceed as follows.

- Remove the starter rope from the rope guide.
- Remove the upper handle by removing the hand knobs and carriage bolts. Lay the upper handle out of the way, being careful not to bend or kink the cable.
- Remove the hairpin clips from the weld pins on the handle brackets. Press outward on the sides of the lower handle, and remove it from the mower.
- Turn the lower handle around so the flat on the bottom is facing upward as shown in figure 13. Reassemble, placing the bottom holes in the handle over the weld pins in the handle mounting bracket.
- Reassemble the upper handle.
- Place the hairpin clips in the **inner** holes in the weld pins and attach the starter rope as instructed in the Assembly Section.

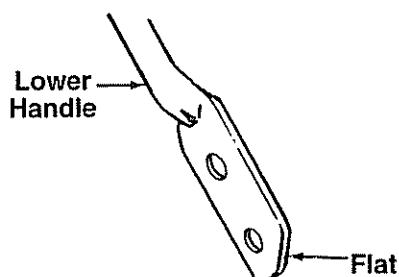

FIGURE 13.

DRIVE CLUTCH ADJUSTMENT

The correct drive clutch adjustment varies with the speed of the mower. The drive clutch adjustment may be checked as follows. Without starting the engine, engage the drive clutch control (squeeze control lever against the handle) and pull the mower backward. The wheels should lock. Then release the drive clutch control and pull the mower backward. It should move freely (or with only a small amount of resistance).

If the wheels lock up when pulled backward with the drive clutch control released (engine off), or if mower

moves forward with the drive clutch control released (engine running), turn the adjustment wheel, located on the left side of the mower at the upper end of the drive clutch cable, toward the left to loosen the cable. See figure 14. Recheck the adjustment as instructed above.

Periodic adjustment may also be necessary due to normal stretch and wear on the belt. Adjustment may be needed if the wheels seem to hesitate, but the engine maintains the same speed. To tighten the cable, move the adjustment wheel toward the right. Recheck the adjustment. If additional adjustment is required, loosen the drive cable as far as possible, unhook the drive cable from the lower adjustment hole in the control handle, and hook it in the upper adjustment hole. Then readjust as instructed above. Always be certain to recheck the adjustment.

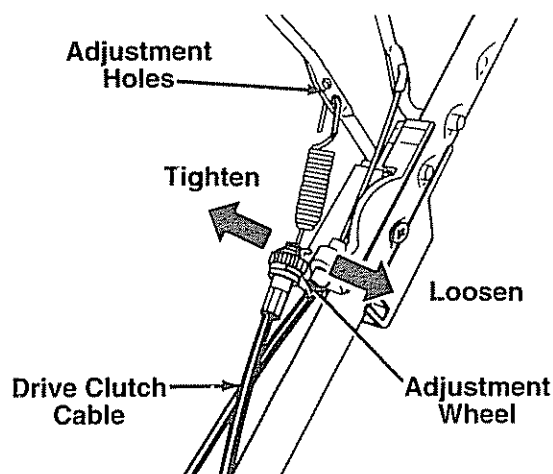

FIGURE 14.

FIVE SPEED SHIFT ADJUSTMENT

Periodic adjustment may be required due to normal wear. Adjustment is needed if the shift lever cannot be moved to all five positions.

- Place the shift lever in high speed (5) position. Refer to figure 7.
- Loosen the nut which is underneath the lever (on the side of the bracket).
- Move the bracket to make certain it is loose. Then slide it towards the rear of the unit as far as it will go, so that the pulley halves (beneath the deck) are against each other. Make certain the belt does not interfere.
- Tighten the nut underneath the lever to secure the bracket in this position.

SERVICE AND ADJUSTMENT

CARBURETOR

Your carburetor has a non-adjustable fixed main jet for mixture control. It has been completely adjusted at the factory. If your engine does not operate properly due to suspected carburetor problems, take your mower to an authorized Sears Service Center for repair and adjustment.

ENGINE SPEED

Your engine slow and fast speeds have been factory set. Do not attempt to increase engine speed or it may result in personal injury. If you believe that the engine is running too fast or too slow, take your mower to an authorized Sears Service Center for repair and adjustment.

REAR TRAIL SHIELD

The rear trail shield, attached between the rear wheels of your mower, is provided to minimize the possibility that objects will be thrown out the rear of the mower toward the operator.

If the shield becomes damaged, it should be replaced.

BELT REMOVAL AND REPLACEMENT

- Disconnect the spark plug wire and ground it against the engine.
- Drain the fuel tank or place a piece of plastic beneath the cap to prevent gasoline leakage.
- Remove the transmission belt cover by removing five self-tapping screws. See figure 15.

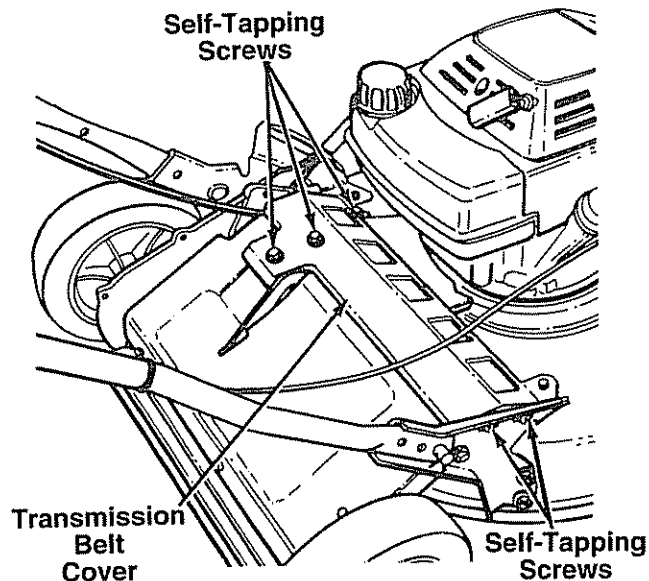

FIGURE 15.

- Tip the mower on its side. Block securely.
- Remove the center bolt which secures the blade to the crankshaft. See figure 16. Remove the blade and blade adapter.

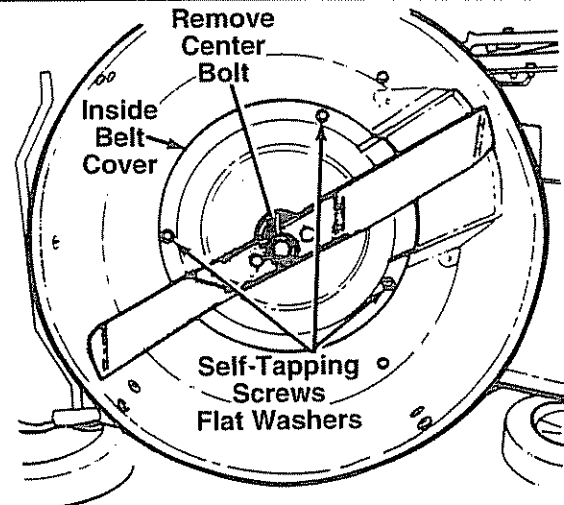

FIGURE 16.

- Remove the inside belt cover by removing three self-tapping screws. A 3/8" wrench is required.
- Roll the belt over the pulley half and remove from around crankshaft.
- Remove the belt from between the idler pulley and the belt guard on the idler pulley bracket. See figure 17.

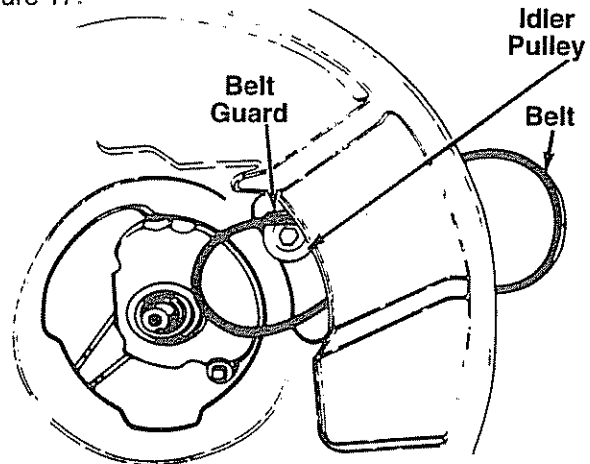

FIGURE 17.

- Remove the belt from the transmission pulley.
- Assemble the new belt as follows.
- Push the idler pulley up out of the way as shown in figure 17.
- Slide the belt in from the rear of the deck, and place it around the transmission pulley.
- Release the idler pulley so it falls down into position. Slide the belt in between the idler pulley and belt guard on the idler pulley bracket.
- Grease the crankshaft. Place belt between the two pulley halves, and reassemble the blade adapter and blade. Reassemble the inside belt cover.
- Reassemble the transmission belt cover.

STORAGE

Your mower and engine should be prepared for off-season storage as follows:

MOWER

- Clean underside of mower housing (See "CLEANING" in "Customer Responsibilities" section of manual).
- Inspect and replace/sharpen blade, if required (See "BLADE CARE" in "Customer Responsibilities" section of manual).
- Lubricate as shown in "Customer Responsibilities" section of manual.

HANDLE

- You can fold your mower's handle for storage as shown in figure 14. Remove the starter rope from the rope guide. Loosen the two hand knobs on the sides of the handle, and let the upper handle fold down to the rear. Move the hairpin clips to the outer hole in the weld pins on the handle mounting brackets. Refer to figure 3. Spread the sides of the lower handle, and push it forward and down.

IMPORTANT: WHEN FOLDING HANDLE FOR STORAGE OR TRANSPORTATION, BE CAREFUL NOT TO BEND OR KINK THE CABLES.

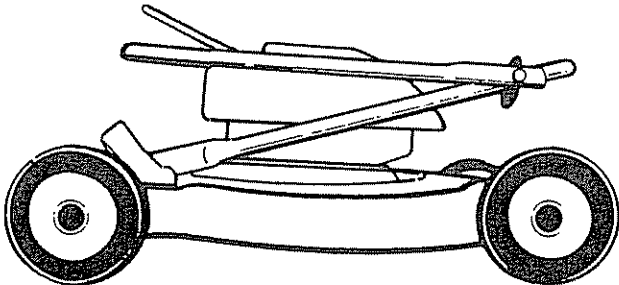

FIGURE 14.

- To place the handle in the operating position, refer to "Assembly" on page 5 of this manual.

ENGINE



WARNING: NEVER STORE YOUR LAWN MOWER INDOORS OR IN AN ENCLOSED, POORLY VENTILATED AREA IF GASOLINE REMAINS IN THE TANK. FUMES MAY REACH AN OPEN FLAME, SPARK OR PILOT LIGHT FROM A FURNACE, WATER HEATER, CLOTHES DRYER, CIGARETTE, ETC.

To prevent engine damage if lawn mower is not used for more than 30 days, proceed as follows.

IMPORTANT: IT IS IMPORTANT TO PREVENT GUM DEPOSITS FROM FORMING IN ESSENTIAL FUEL SYSTEM PARTS SUCH AS CARBURETOR, FUEL FILTER, FUEL HOSE, OR TANK DURING STORAGE. ALSO, FUEL (CALLED GASOHOL OR USING ETHANOL OR METHANOL) CAN ATTRACT MOISTURE WHICH LEADS TO SEPARATION AND FORMATION OF ACID DURING STORAGE. ACIDIC GAS CAN DAMAGE THE FUEL SYSTEM OF AN ENGINE WHILE IN STORAGE.

NOTE: Fuel stabilizer is an acceptable alternative in minimizing formation of fuel gum deposits during storage. Add stabilizer to gasoline in fuel tank in fuel tank or storage container. Always follow mix ratio found on stabilizer container. Run engine at least 10 minutes after adding stabilizer to allow stabilizer to reach the carburetor. Do not drain gas tank and carburetor if using stabilizer.

- Drain the fuel tank. Start the engine, and let it run until fuel lines and carburetor are empty.
- When storing the mower at the end of the season, change the engine oil. Drain the oil after the engine has been operated and is still warm, and refill the crankcase with fresh oil.
- Lubricate the piston/cylinder area by first removing the spark plug and squirting clean engine oil into the spark plug hole. Then cover the spark plug hole with a rag to absorb oil spray. Next, rotate the engine by pulling the starter two or three times. Finally, reinstall spark plug and attach spark plug wire.

OTHER

- Do not store gasoline from one season to another.
- Replace your gasoline can if your can starts to rust. Rust and/or dirt in your gasoline can cause problems.
- Do not store your mower under any plastic cover. Plastic cannot breathe which allows condensation to form and cause the metal components of your mower to rust.

TROUBLE SHOOTING GUIDE

Trouble	Possible Cause(s)	Corrective Action
Engine fails to start	<ol style="list-style-type: none"> 1. Blade control handle disengaged. 2. Spark plug wire disconnected. 3. Throttle control lever not in starting position. 4. Fuel tank empty, or stale fuel. 5. Blocked fuel line. 6. Faulty spark plug. 7. Engine flooded. 	<ol style="list-style-type: none"> 1. Engage blade control handle. 2. Connect wire to spark plug. 3. Move throttle lever to starting position. 4. Fill tank with clean, fresh gasoline. 5. Clean fuel line. 6. Clean, adjust gap or replace. 7. Remove spark plug, dry the plug, and crank engine with plug removed and throttle in off position. Replace spark plug, connect wire and resume starting procedures.
Engine runs erratic	<ol style="list-style-type: none"> 1. Spark plug wire loose. 2. Blocked fuel line or stale fuel. 3. Vent in gas cap plugged. 4. Water or dirt in fuel system. 5. Dirty air cleaner. 	<ol style="list-style-type: none"> 1. Connect and tighten spark plug wire. 2. Clean fuel line; fill tank with clean, fresh gasoline. 3. Clear vent. 4. Drain fuel tank. Refill with fresh fuel. 5. Clean air cleaner. See "Customer Responsibilities" section of this manual.
Engine overheats	<ol style="list-style-type: none"> 1. Engine oil level low. 2. Air flow restricted. 	<ol style="list-style-type: none"> 1. Fill crankcase with proper oil. 2. Clean lawn mower engine.
Occasional skip (hesitates) at high speed	Spark plug gap too close.	Adjust gap to .030".
Idles poorly	<ol style="list-style-type: none"> 1. Spark plug fouled, faulty or gap too wide. 2. Dirty air cleaner. 	<ol style="list-style-type: none"> 1. Reset gap to .030" or replace spark plug. 2. Clean air cleaner. See "Customer Responsibilities" section of this manual.
Excessive vibration	<ol style="list-style-type: none"> 1. Cutting blade loose or unbalanced. 2. Bent cutting blade. 3. Bent engine crankshaft. 	<ol style="list-style-type: none"> 1. Tighten blade and adapter. Balance blade. 2. Replace blade. 3. Contact your SEARS Service Center.
Mower will not mulch grass	<ol style="list-style-type: none"> 1. Engine speed too low. 2. Wet grass. 3. Excessively high grass. 4. Dull blade. 	<ol style="list-style-type: none"> 1. Move throttle lever to FAST position. 2. Do not mow when grass is wet; wait until later to cut. 3. Mow once at a high cutting height, then mow again at desired height or make a narrower cutting swath (1/2 width). Do not cut off more than 1/3 of the total length of the grass at any one cutting. 4. Sharpen or replace blade.
Uneven cut	<ol style="list-style-type: none"> 1. Wheels not positioned correctly. 2. Dull blade. 	<ol style="list-style-type: none"> 1. Place all four wheels in same height position. 2. Sharpen or replace blade.
Mower propels with clutch disengaged	Drive clutch control adjustment needed.	Adjust drive clutch control. See "Service and Adjustment" section of this manual.
Mower will not propel	<ol style="list-style-type: none"> 1. Belt has stretched; drive clutch control adjustment needed. 2. Wet grass. 	<ol style="list-style-type: none"> 1. Adjust drive clutch control. See "Service and Adjustment" section of this manual. 2. Do not mow when grass is wet; wait until later to cut.

Note: For repairs beyond the minor adjustments listed above, contact your nearest SEARS Service Center.

SEARS CRAFTSMAN 21" MULCHING ROTARY MOWER MODEL NO. 247.372650

Repair Parts

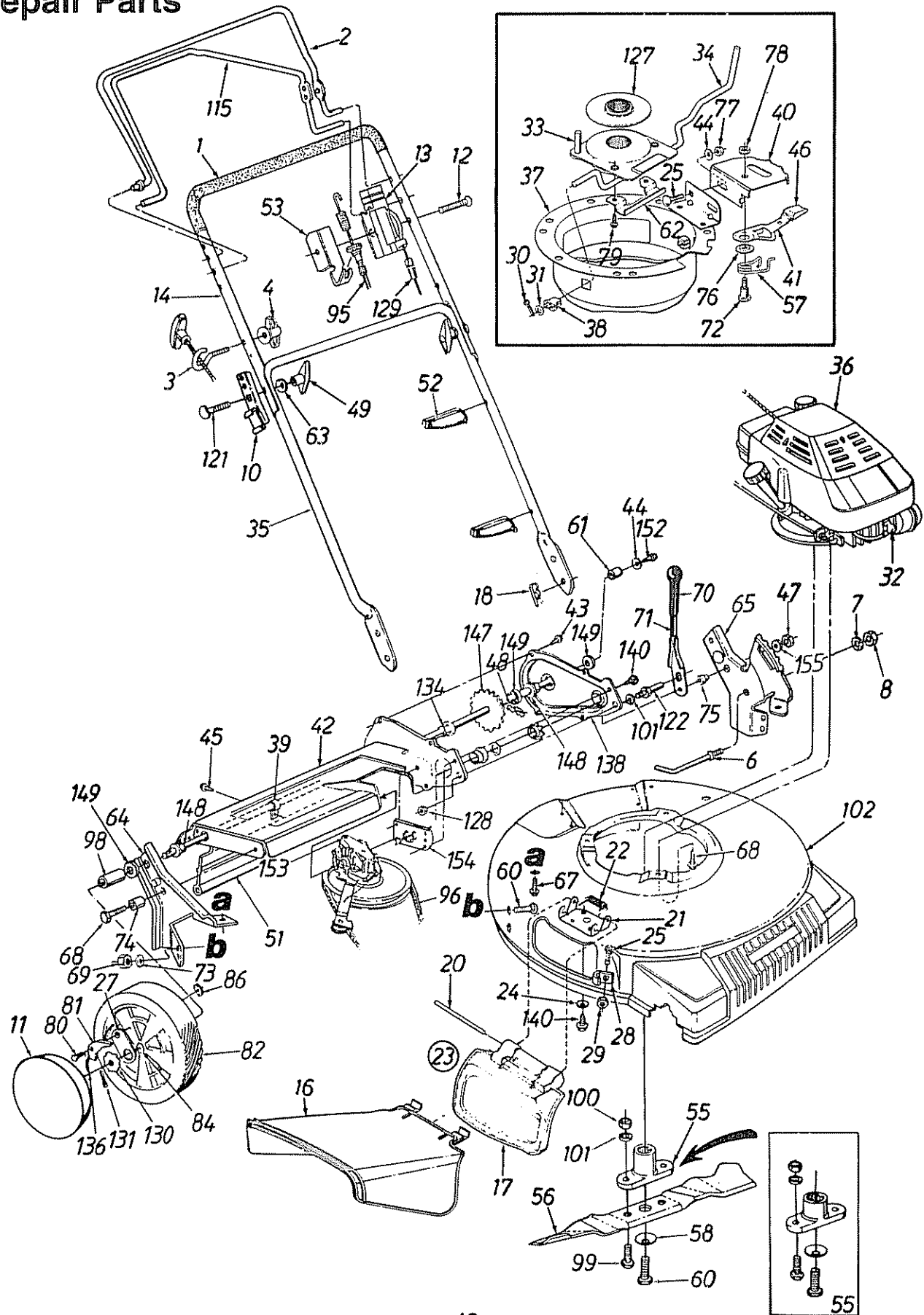

SEARS CRAFTSMAN 21" MULCHING ROTARY MOWER MODEL NO. 247.372650

Repair Parts

KEY NO.	PART NO.	DESCRIPTION	KEY NO.	PART NO.	DESCRIPTION
1	720-0226	Grip	61	748-0190	Spacer .513" I.D.
2	747-0824	Control Handle	62	782-7563	Bracket—Shift Plate
3	710-1205	Rope Guide	63	736-0451	Saddle Washer .32" I.D.
4	712-0397	Wing Nut 1/4-20 Thd.	64	682-3006A	R.H. Handle Wheel Brkt. Ass'y.
6	747-0855	Belt Guard	65	682-3007A	L.H. Handle Wheel Brkt. Ass'y.
7	736-0329	L-Wash. 1/4" I.D.*	66	710-0260	Carriage Bolt 5/16-18 x .62"
8	712-0287	Hex Nut 1/4-20 Thd.*	67	710-0603	Hex B-Tap Scr. 5/16-18
10	782-7007	Grass Catcher Bracket	68	710-0654A	Hex TT-Tap Scr. 3/8-16
11	731-0981A	Hub Cap	69	712-0267	Hex Nut 5/16-18 Thd.*
12	710-0605	Oval C-Sunk Mach. Scr.	70	720-0230	Grip
13	746-0875	Throttle Body	71	732-0725	Height Adj. Lever
14	749-0539B	Upper Handle	72	738-0138	Shld. Bolt .437" Dia.
16	731-1407	Side Chute Deflector	73	736-0242	Bell-Wash. 5/16" I.D.
17	731-1404	Mulch Plug	74	750-0736	Spacer .383" I.D.
18	714-0104	Internal Cotter Pin 5/16" Dia.	75	750-0624	Shld. Spacer .5" Dia.
20	747-0710	Hinge Pin	76	736-0289	Shld. Spacer .5" Dia. x .134"
21	782-7006	Plug Adapter	77	712-0291	Hex L-Nut 1/4-20 Thd.
22	732-0731	Torsion Spring	78	712-0158	Hex L-Nut 5/16-18 Thd.
23	682-7000	Mulch Plug Ass'y. Comp. (Incl. Ref. 17, 20, 21, 22)	79	710-0653	Hex Wash. Hd. Tap Scr. 1/4-20 x .38" Lg.
24	736-0270	Bell-Wash. .265" I.D. x .75" O.D.	80	738-0137	Shld. Scr. .342" Dia. x .268
25	710-0167	Carriage Bolt 1/4-20 x .5" Lg.	81	748-0188B	Pawl
27	16855	Pawl Plate	82	734-1510B	Wheel Ass'y. Comp.—Rear
28	782-7009	Chute Stop Bracket	84	741-0486B	Sleeve Bearing 1/2" I.D.
29	712-0324	Hex L-Nut 1/4-20 Thd.	86	712-0414	Weld Top L-Nut 1/4-20 Thd.
30	714-0507	Cotter Pin 3/32" Dia. x .75"	95	746-0911	S.P. Cable
31	736-0278	FI-Wash. .328" I.D. x .68"	96	754-0343	"V"-Belt
32	735-0639	Spark Plug Insulator	98	711-0313	Sleeve .526" I.D.
33	682-7511	Lower Pulley Half Ass'y.	99	710-1055	Hex Bolt 3/8-24 x 1.0" Lg.
34	747-0883	Shift Rod	100	712-0241	Hex Nut 3/8-24 Thd.
35	749-0928	Lower Handle	101	736-0169	L-Wash. 3/8" I.D.
36	143.434132	Engine—Craftsman Model 143.434132	102	782-0023	21" Deck Ass'y.
37	682-7514	Housing Ass'y.	115	747-0884	Self-Propelled Control Lever
38	731-1137	Flanged Bushing	121	710-1174	Curved Hd. Bolt 5/16-18 x 2" Lg.
39	726-0287	Clamp	122	711-0805	Shld. Pin 1.43" Lg.
40	782-7560	Shift Adj. Plate	127	756-0976	Pulley Half—Serrated
41	732-0724	Shift Lever	128	712-0711	Hex Jam Nut 3/8-24 Thd.*
42	682-7513	Chain—Axle Ass'y.	129	746-0737	Control Cable—51"
43	710-0352	Hex B-Tap Scr. 1/4" x .38"	130	748-0318	Ratchet Wheel 1.62" O.D.
44	736-0270	Bell-Wash. 1/4" I.D.	131	714-0115	Cotter Pin 1/8" Dia. x 1"
45	710-0351	Truss Mach. B-Tap Scr. #10 x .5"	134	741-0522	Hex Flange Bearing
46	720-0190	Sping Lever Knob	136	10622B	Spring—Nylon
47	712-0296	Hex Patch L-Nut 3/8-24 Thd.	138	682-7506	Chain Cover Ass'y.
48	713-0361	#48 Chain .500" Pitch x 38 Links	140	710-0599	Hex TT-Tap Scr. 1/4-20 x .50"
49	720-0241	Hand Knob	147	738-0864	Rear Shaft Ass'y. 21.44" Lg.
51	731-1421	Rear Flap 3.75" x 17.5" Lg.	148	741-0324	Hex Flange Brg. .506" I.D.
52	726-0240	Cable Tie	149	736-0160	FI-Wash. .531" I.D. x .930"
53	782-7559	Drive Control Bracket	152	710-0751	Hex Bolt 1/4-20 x .62" Lg. (Grade 5)
55	753-0519	Blade Adapter Kit	153	618-0055	Transmission Comp. (See Breakdown)
56	742-0721	21" Mulching Blade	154	16500A	Hex Bearing Cup
57	732-0719	Torsion Spring	155	736-0300	FI-Wash. .385" I.D. x .87" O.D.
58	736-0453	Bell-Wash. .47" I.D. x 1.14" O.D.	—	770-8274H	Owner's Manual
60	710-0561	Hex Bolt 7/16-20 x 2.5"			

*Common Hardware—May Be Purchased Locally.

NOTE: Specifications subject to change without notice or obligation.

SEARS CRAFTSMAN 21" MULCHING ROTARY MOWER MODEL NO. 247.372650

Repair Parts

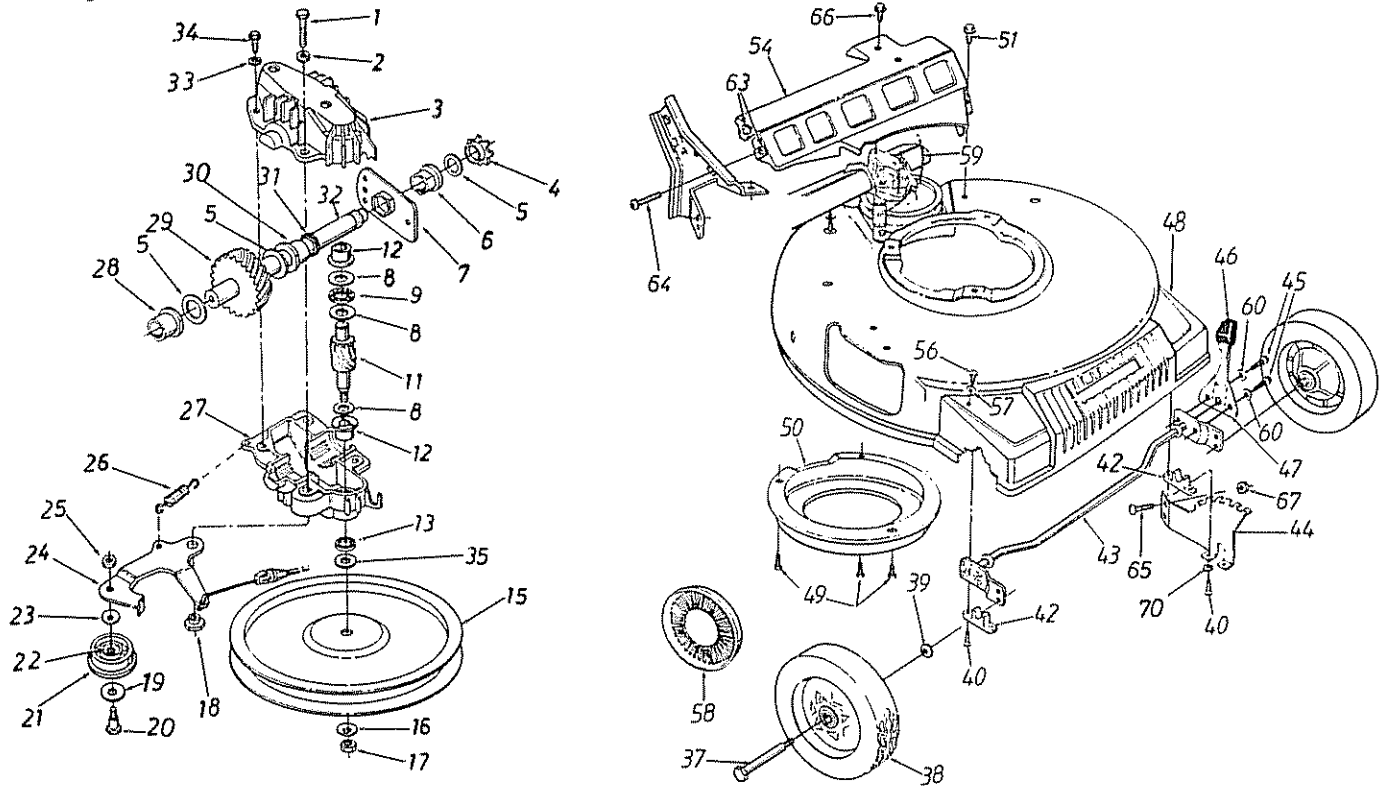

KEY NO.	PART NO.	DESCRIPTION	KEY NO.	PART NO.	DESCRIPTION
1	710-1062	Hex Patch Bolt 1/4-20 x 1.25"†	33	736-0722	L-Wash. #10 I.D.†
2	736-0329	L-Wash. 1/4" I.D.*	34	710-0436	Hex B-Tap Scr. #10 x .62"†
3	717-0418A	Upper Hsg. Half†	35	736-0410	Hex Washer .26" x .88"
4	713-0400	#48 Sprocket 7 T x 1/2 Pitch†	36	618-0055	Transmission Comp.
5	736-0336	Fl-Wash. 5/8" I.D. x .030†	37	738-0102	Front Axle Bolt
6	741-0413	Hex Flange Brg. .631" I.D.†	38	734-1512A	Wheel Ass'y. Comp. 8 x 2"
7	16500A	Hex Bearing Cup†	39	736-0105	Bell-Wash. .380" I.D. x .88
8	736-0314	Thrust Wash. .382" I.D. x .70" O.D.†	40	710-1241	Hex Wash. Hd. Scr. 1/4 x 1" Lg.
9	741-0479	Thrust Bearing .375" I.D. x .812" O.D.†	42	741-0492A	Block Bushing
11	717-1216	11 Tooth Pinion Shaft†	43	17733	Axle Ass'y.
12	748-0208A	Flange Bearing†	44	782-0516	Height Adj. Bracket
13	721-0212	Oil Seal†	45	710-0653	Hex TT-Tap Scr. 1/4-20 x .38"
15	756-0330A	Fl-Pulley 5.06" O.D.	46	720-0190	Knob
16	736-0270	Bell-Wash. .265" I.D. x .75"	47	732-0639	Spring Lever
17	712-0351	Hex L-Nut 1/4-28 L.H. Thd.	48	731-1281	Plastic Front End
18	738-0440	Shld. Spacer .375" Dia. x .170	49	710-0352	Hex B-Tap Scr. 1/4" x .38"
19	736-0344	Fl-Wash. .390" I.D. x 1.0"	50	782-7558	Belt Cover
20	738-0826	Shld. Bolt .375" Dia. x .40"	51	710-0599	Hex Wash. Hd. TT-Scr. 1/4-20
21	756-0558	Fl-Idler Plastic 1.50" Dia.	54	782-7554	Transmission Belt Cover
22	741-0556	Needle Brg. .375" x .31	56	710-1242	Torx Truss Hd. Scr. 5/16 x .75"
24	17052A	Idler Brk't. Ass'y.	57	736-0242	Bell-Wash. .345" I.D. x .88"
25	712-0138	Hex Patch L-Nut 1/4-28 Thd.	58	731-0981A	Hub Cap
26	732-0357	Extension Spring 1.12" Lg.	59	746-0909	S.P. Cable
27	717-0419A	Lower Hsg. Half†	60	736-0222	External L-Wash. 1/4" I.D.
28	741-0415	Flange Bearing .566 Dia.†	63	712-0147	Speed Nut #10-24 Thd.
29	717-0422A	33 Tooth Helical Gear†	64	710-1003	Hex Tap Scr. #10-16 x .5" Lg.
30	741-0414	Flange Bearing .629 Dia.†	65	710-0167	Carr. Bolt 1/4-20 x .5" Lg.
31	721-0213	Oil Seal .625 Dia.†	66	710-0603	Hex B-Tap Scr. 5/16-18 x .5"
32	738-0607A	Gear Sprocket Shaft†	67	712-3027	Hex Flange L-Nut 1/4-20 Thd.
			70	736-0329	L-Wash. 1/4" I.D.*

†Part of Transmission Complete, Ref. No. 36.

CRAFTSMAN 5 H.P. ENGINE MODEL NO. 143.434132

Repair Parts

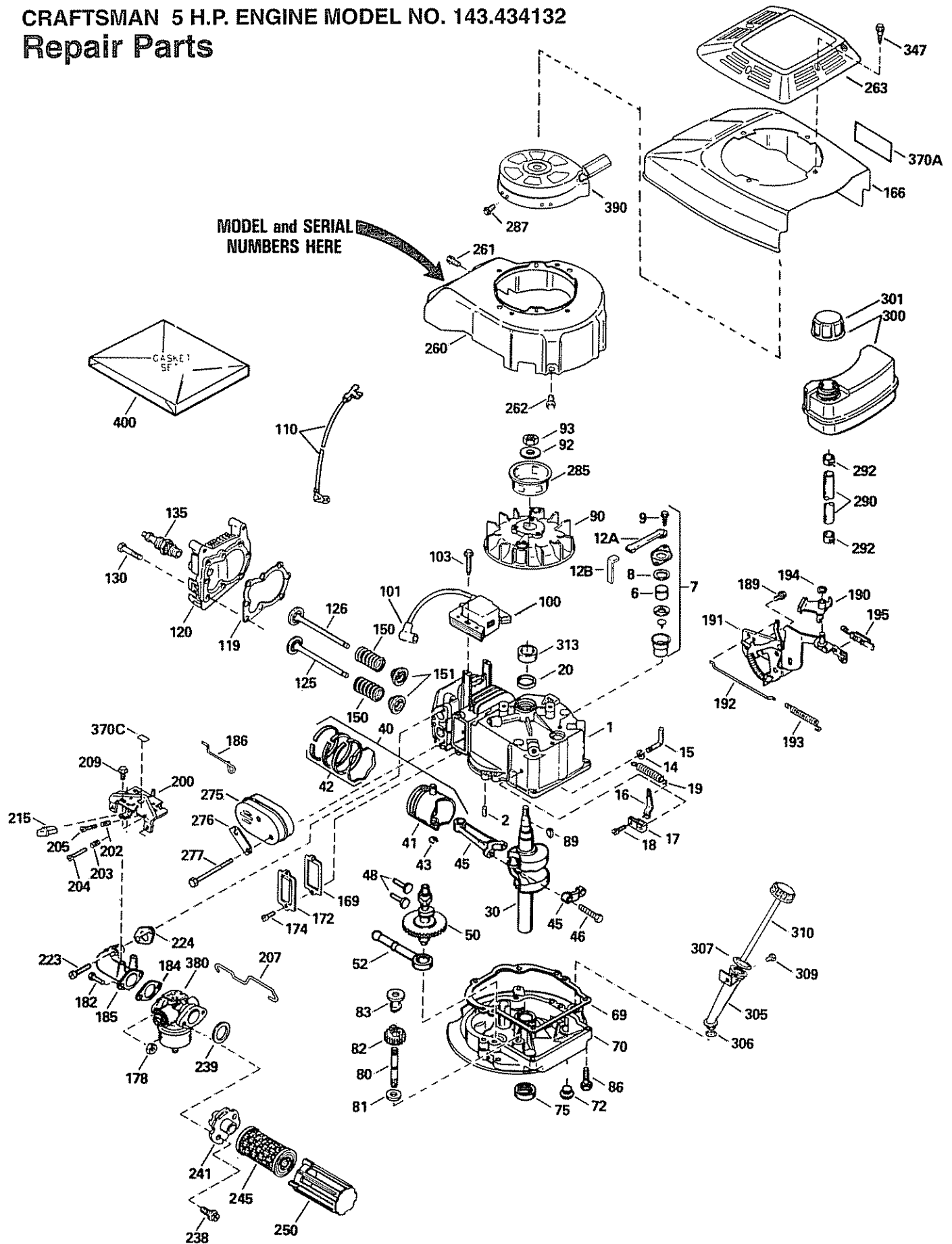

CRAFTSMAN 5 H.P. ENGINE MODEL NO. 143.434132

Repair Parts

KEY NO.	PART NO.	DESCRIPTION	KEY NO.	PART NO.	DESCRIPTION
1	36265	Cylinder Ass'y. (Incl. Nos. 2 & 20)	100	34443A	Solid State Ass'y.
2	26727	Pin, Dowel	101	610118	Cover, Spark Plug
6	33734	Element, Breather	103	650814	Screw, Torx T-15 Hex Washer Hd. Sems, 10-24 x 1
7	34214A	Breather Ass'y. (Incl. Nos. 6, 8, 9, 12A & 12B)	110	34961	Wire, Ground
8	*33735	Gasket, Breather	119	33554A	Gasket, Cylinder Head
9	30200	Screw, Hex Washer Hd. Self-Tap Sems, 10-24 x 9/16	120	34342	Head, Cylinder
12A	33886	Tube, Breather	125	29313C	Valve, Exhaust (Std.) (Incl. No. 151)
12B	34695	Elbow, Breather Tube	125	29315C	Valve, Exhaust (1/32" Oversize) (Incl. No. 151)
14	28277	Washer, Flat	126	29314B	Valve, Intake (Std.) (Incl. No. 151)
15	30589	Rod, Governor (Incl. No. 14)	126	29315C	Valve, Intake (1/32" Oversize) (Incl. No. 151)
16	31383A	Lever, Governor	130	6021A	Screw, Hex Flange Hd., 5/16-18 x 1-1/2
17	31335	Clamp, Governor Lever	135	35395	Spark Plug, Resistor (Champion RJ-19LM or equivalent)
18	650548	Screw, Hex Washer Hd., 8-32 x 5/16	150	35991	Spring, Valve
19	36281	Spring, Extension	151	31673	Cap, Lower Valve Spring
20	32600	Seal, Oil	166	35827	Shroud, Engine
30	35606	Crankshaft Ass'y.	169	*27234A	Gasket, Valve Spring Box
40	36073	Piston, Pin & Ring Ass'y. (Std.) (Incl. Nos. 41, 42 & 43)	172	32755	Cover, Valve Spring Box
40	36074	Piston, Pin & Ring Ass'y. (.010 Oversize) (Incl. Nos. 41, 42 & 43)	174	650128	Screw, Hex Hd. Sems, 10-24 x 1/2
40	36075	Piston, Pin & Ring Ass'y. (.020 Oversize) (Incl. Nos. 41, 42, & 43)	178	29752	Nut & Lock Washer, 1/4-28
41	36070	Piston & Pin Ass'y. (Std.) (Incl. No. 43)	182	6201	Screw, Hex Hd. Cap, 1/4-28 x 7/8
41	36071	Piston & Pin Ass'y. (.010 Oversize) (Incl. No. 43)	184	*26756	Gasket, Carburetor
41	36072	Piston & Pin Ass'y. (.020 Oversize) (Incl. No. 43)	185	31384A	Pipe, Intake (Incl. No. 224)
42	36076	Ring Set, Piston (Std.)	186	34337	Link, Governor Spring
42	36077	Ring Set, Piston (.010 Oversize)	189	650839	Screw, Hex Hd. Sems Powerlok, 1/4-20 x 3/8
42	36078	Ring Set, Piston (.020 Oversize)	190	35831	Lever, Brake
43	20381	Ring, Piston Pin Retaining	191	35039B	Bracket, S.E. Brake (Incl. No. 195)
45	30963B	Rod Ass'y., Connecting (Incl. No. 46)	192	34966	Link, Control
46	32610A	Bolt, Connecting Rod	193	34965	Spring, Extension
48	27241	Valve, Lifter	194	32309	Ring, Retaining
50	35992	Camshaft (Mech. Compression Release)	195	610973	Terminal Ass'y.
52	29914	Pump Ass'y., Oil	200	35727	Bracket Ass'y., Control (Incl. No. 202 thru 205)
69	*35261	Gasket, Mounting Flange	202	33802	Spring, Compression
70	34311D	Flange, Mounting (Incl. Nos. 72, 75, 80, 81, 82 & 83)	203	31342	Spring, Compression
72	36083	Plug, Oil Drain	204	650549	Screw, Fil. Hd., 5-40 x 7/16
75	27897	Seal, Oil	205	650777	Screw, Fil. Hd., 6-32 x 21/32
80	30574A	Shaft, Governor	207	34336	Link, Throttle
81	30590A	Washer, Flat	209	30200	Screw, Hex Washer Hd., Self-Tap Sems, 10-24 x 9/16
82	30591	Gear Ass'y., Governor (Incl. No. 81)	215	35511	Knob, Control
83	30588A	Spool, Governor	223	650451	Screw, Hex Hd. Sems, 1/4-20 x 1
86	650488	Screw, Hex Hd. Sems, 1/4-20 x 1-1/4	224	*34690A	Gasket, Intake Pipe
89	611004	Key, Flywheel	238	650932	Screw, Hex Washer Hd. Shoulder, 10-32 x 49/64
90	611112	Flywheel	239	*34338	Gasket, Air Cleaner
92	650815	Washer, Belleville	241	35797	Collar, Air Cleaner
93	650816	Nut, Flywheel	245	35066	Filter, Air Cleaner (Paper)
			250	35065	Cover, Air Cleaner
			260	35826	Housing, Blower
			261	30200	Screw, Hex Washer Hd. Self-Tap Sems, 10-24 x 9/16
			262	650831	Screw, Hex Washer Hd. Powerlok Thread, 1/4-20 x 15/32

CRAFTSMAN 5 H.P. ENGINE MODEL NO. 143.434132

Repair Parts

KEY NO.	PART NO.	DESCRIPTION	KEY NO.	PART NO.	DESCRIPTION
263	35821	Grill, Recoil	307	35499	"O"-Ring
275	34613	Muffler Ass'y. (Incl. No. 277)	309	650936	Screw, Hex Washer Hd. Shakeproof, 10-32 x 13/32
276	33753	Plate, Lock			Dipstick, Oil Fill
277	650795	Screw, Hex Hd., 1/4-20 x 2-1/4	310	35822	Spacer, Flywheel Key
285	35000	Hub, Starter	313	34080	Screw, Hex Washer Hd. Shoulder, 10-32 x 27/32
287	650926	Screw, Hex Washer Hd., 8-32 x 21/64	347	650898	Decal, Instruction
290	34357	Line, Fuel	370A	35977	Decal, Throttle
292	26460	Clamp, Fuel Line	370C	35167	Carburetor (Incl. No. 184)
300	35586	Tank Ass'y. (Incl. Nos. 292 & 301)	380	632644	Starter, Rewind
301	35355	Cap, Fuel	390	590637	Gasket Set (Incl. Items Marked *)
305	35819A	Tube, Oil Fill	400	35997	
306	*34265	Gasket, Fill Tube			

RPM Setting:
 Low Speed: 2750-3050
 High Speed: 3200-3400

*Indicates Parts Included in Gasket Set, Ref. No. 400.

Optional Spark Arrester Screen for the Muffler—
 Order Part No. 391022.

Repair Parts

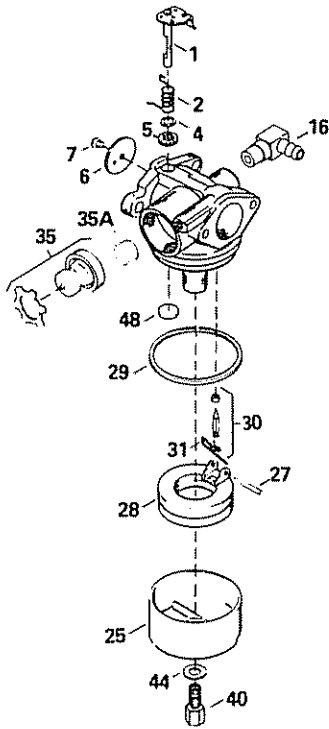

PARTS LIST FOR CARBURETOR

KEY NO.	PART NO.	DESCRIPTION
—	632644	Carburetor Comp.
1	631615	Throttle Shaft & Lever Ass'y.
2	631767	Throttle Return Spring
4	631184	Dust Seal Washer (Throttle)
5	631183	Dust Seal (Throttle)
6	632590	Throttle Shutter
7	650506	Throttle & Choke Shutter Screw
16	632527	Fuel Fitting
25	631867	Float Bowl
27	631024	Shaft, Float
28	632019	Float
29	631028	O-Ring, Float Bowl to Body
30	631021	Inlet Needle, Seat & Clip (Incl. No. 31)
31	631022	Spring Clip
35	36045	Primer Bulb/Retainer Ring
35A	632647	Primer Bulb Filter
40	632578	High Speed Bowl Nut
44	27110	Bowl Nut Washer
48	631027	Welch Plug, Atmospheric Vent

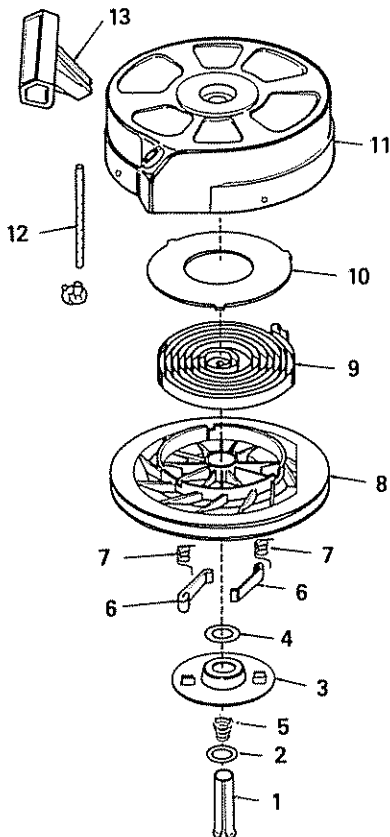

PARTS LIST FOR REWIND STARTER

KEY NO.	PART NO.	DESCRIPTION
—	590637	Starter, Rewind
1	590599A	Pin, Spring (Incl. No. 4)
2	590600	Washer
3	590615	Retainer
4	590601	Washer
5	590598	Spring, Brake
6	590616	Dog, Starter
7	590617	Spring, Dog
8	590618	Pulley
9	590619	Spring, Rewind
10	590620	Cover, Spring
11	590638	Housing Ass'y., Starter
12	590535	Rope, Starter (Length 98" & 9/64" Dia.)
13	590452	Handle, Starter

USE THIS PAGE AS A GUIDE TO DETERMINE SLOPES WHERE YOU MAY NOT OPERATE SAFELY.

SLOPE GAUGE

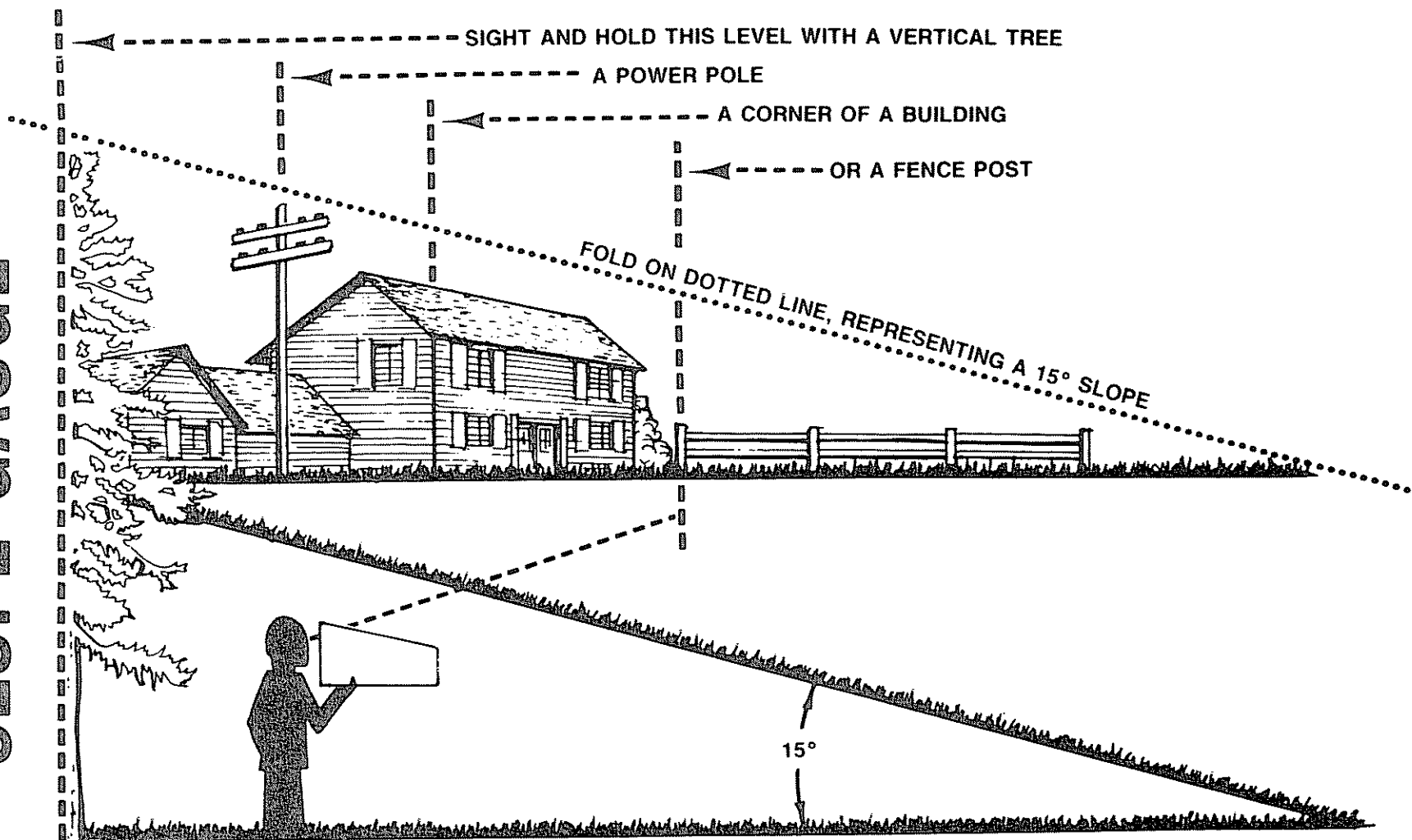

23



WARNING

Do not mow on inclines with a slope in excess of 15 degrees (a rise of approximately 2-1/2 feet every 10 feet). If operating a walk-behind mower on such a slope, it is extremely difficult to maintain your footing and you could slip, resulting in serious injury.

Operate WALK-BEHIND mowers across the face of slopes, never up and down slopes.

SEARS

OWNER'S MANUAL

**MODEL NO.
247.372650**

HOW TO ORDER REPAIR PARTS

CRAFTSMAN®

5.0 HORSEPOWER 21" POWER PROPELLED 5-SPEED "3-IN-1" MULCHING ROTARY MOWER

Each lawn mower has its own model number. Each engine has its own model number.

The model number for your lawn mower will be found on a label attached to the lawn mower on the top rear of the deck.

The model number for the engine will be found on the blower housing of the engine adjacent to the spark plug.

All parts listed herein may be ordered through Sears, Roebuck and Co. Service Centers and most Retail Stores.

WHEN ORDERING REPAIR PARTS, ALWAYS GIVE THE FOLLOWING INFORMATION:

- * PRODUCT - "21" Mulching Rotary Mower"
- * MODEL NUMBER - 247.372650
- * ENGINE MODEL NUMBER - 143.434132
- * PART NUMBER
- * PART DESCRIPTION

Your Sears merchandise has added value when you consider that Sears has service units nationwide staffed with Sears trained technicians...professional technicians specifically trained on Sears products, having the parts, tools and the equipment to insure that we meet our pledge to you...we service what we sell.

SEARS, ROEBUCK AND CO., Hoffman Estates, IL 60179 U.S.A.