

Owner's Manual

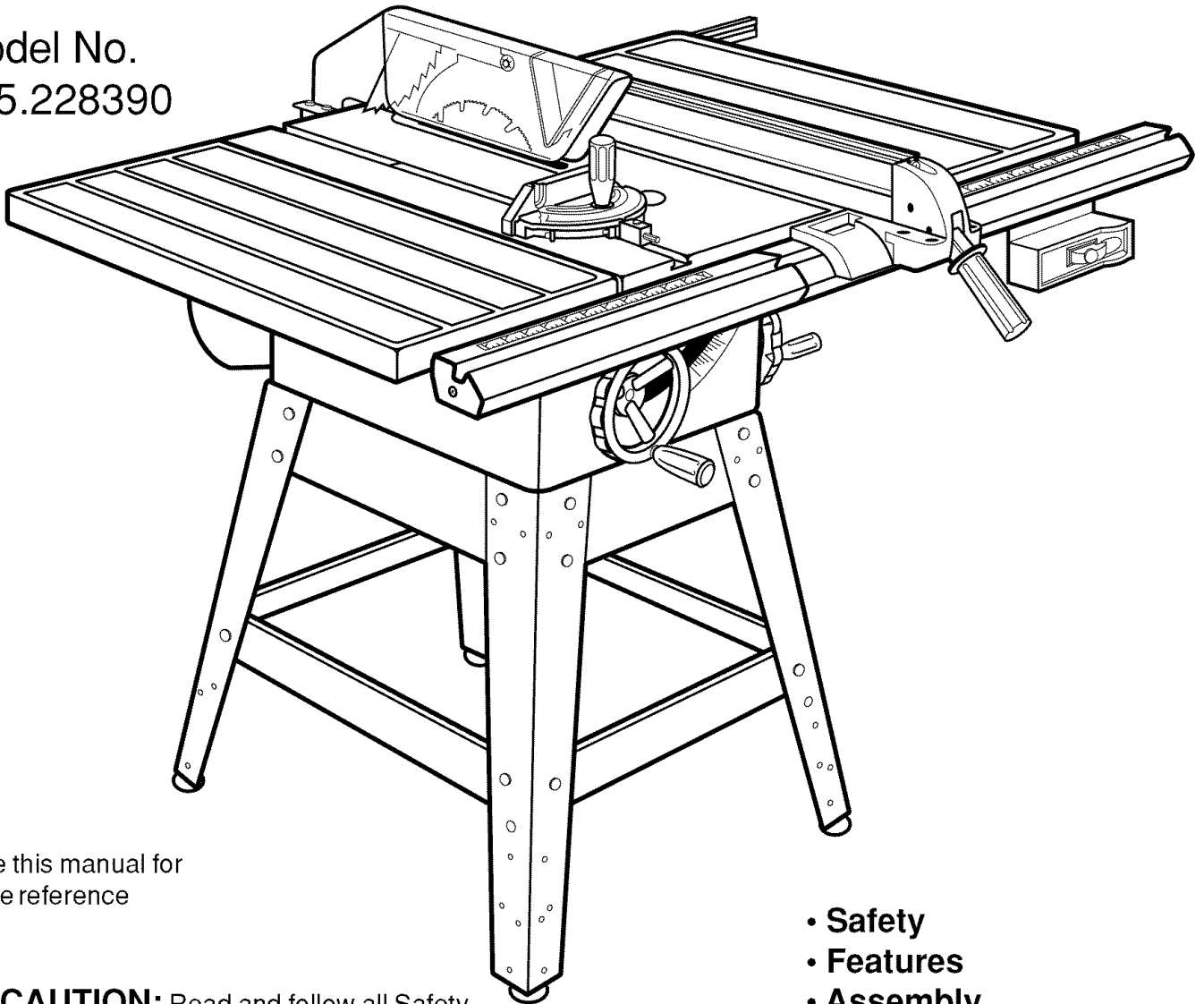

10 in. Stationary TABLE SAW

Model No.
315.228390



Save this manual for
future reference

CAUTION: Read and follow all Safety Rules and Operating Instructions before first use of this product.

Customer Help Line: 1-800-932-3188

Sears, Roebuck and Co., Hoffman Estates, IL 60179 USA
Visit the Craftsman web page: www.sears.com/craftsman

- Safety
- Features
- Assembly
- Operation
- Maintenance
- Parts List



WARRANTY

FULL ONE YEAR WARRANTY ON CRAFTSMAN TABLE SAW

If this **CRAFTSMAN** Table Saw fails due to a defeat in material or workmanship within one year from the date of purchase, Sears will repair it, free of charge.

Contact a Sears Service Center for repair.

If this product is used for commercial or rental purposes, this warranty applies only for 90 days from the date of purchase.

This warranty gives you specific legal rights, and you may also have other rights which vary from state to state.

Sears, Roebuck and Co., Dept. 817WA, Hoffman Estates, IL 60179

INTRODUCTION

Your saw has many features for making cutting operations more pleasant and enjoyable. Safety, performance and dependability have been given top priority in the design of this saw making it easy to maintain and operate.

CAUTION: Carefully read through this entire owner's manual before using your new saw. Pay close attention to the Rules For Safe Operation, and all Safety Alert Symbols, including Danger, Warning and Caution. If you use your saw properly and only for what it is intended, you will enjoy years of safe, reliable service.

Look for this symbol to point out important safety precautions. It means attention!!! Your safety is involved.

WARNING:

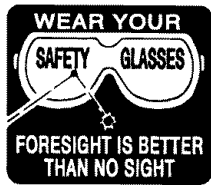

The operation of any power tool can result in foreign objects being thrown into your eyes, which can result in severe eye damage. Before beginning power tool operation, always wear safety goggles or safety glasses with side shields and a full face shield when needed. We recommend a Wide Vision Safety Mask for use over eyeglasses or standard safety glasses with side shields, available at Sears Retail Stores.

TABLE OF CONTENTS

■ Warranty and Introduction	2
■ Table Of Contents	2-3
■ Rules For Safe Operation	4-6
■ Electrical	7
■ Glossary and Product Specifications	8
■ Unpacking and Accessories	9
■ Loose Parts List	10
■ Small Parts List	11-12
■ Tools Needed	13
■ Labels	14-15
■ Features	16-17
■ Assembly	18-29
Installing Handwheels on Table Saw Base	18
Assembling Leg Stand	18-19

TABLE OF CONTENTS (CONT.)

Mounting the Leg Stand on the Table Saw Base	19
Assembling Table Extensions	20
Aligning Table Extensions	20
Installing the Rear Rail	21
Installing the Front Rail	22
Aligning Rip Fence and Rails	23
Mounting the Motor	23
Installing the Belt and Belt Guard	24
Checking the Throat Plate	24
Installing the Blade Guard	25
Aligning the Riving Knife with the Blade	26
Check Heeling (Paralleling) of the Saw Blade to the Miter Gage Groove	27
Checking Rip Fence and Blade Alignment	28
Checking Squareness of Extension Tables to Saw Table	29
■ Adjustments	30-34
Replacing the Blade	30
Heeling (Paralleling) the Sawblade to Miter Gage Groove	31-32
Setting the Bevel Stops and Indicator	32-33
Adjusting the Miter Gage	33
Removing / Replacing the Throat Plate	34
■ Basic Operation of the Table Saw	35-42
Causes of Kickback	35
Avoiding Kickback	35
Cutting Aids	35
Types of Cuts	36
Making a Cross Cut	37
Making a Rip Cut	37-38
Making a Miter Cut	38
Making a Bevel Cross Cut	38-39
Making a Bevel Rip Cut	39
Making a Compound (Bevel) Miter Cut	40
Making a Large Panel Cut	41
Making a Non-Through Cut	41
Making a Dado Cut	42
■ Maintenance	43
■ Lubrication	43
■ Troubleshooting	44-46
■ Exploded View and Repair Parts List	48-65
■ Parts Ordering / Service	back page

RULES FOR SAFE OPERATION

The purpose of safety symbols is to attract your attention to possible dangers. The safety symbols, and the explanations with them, deserve your careful attention and understanding. The safety warnings do not by themselves eliminate any danger. The instructions or warnings they give are not substitutes for proper accident prevention measures.

SYMBOL MEANING



SAFETY ALERT SYMBOL

Indicates danger, warning, or caution. May be used in conjunction with other symbols or pictographs.



DANGER: Failure to obey a safety warning will result in serious injury to yourself or to others.

Always follow the safety precautions to reduce the risk of fire, electric shock and personal injury.



WARNING: Failure to obey a safety warning can result in serious injury to yourself or to others.

Always follow the safety precautions to reduce the risk of fire, electric shock and personal injury.



CAUTION: Failure to obey a safety warning may result in property damage or personal injury to yourself or to others. Always follow the safety precautions to reduce the risk of fire, electric shock and personal injury.

Note: Advises you of information or instructions vital to the operation or maintenance of the equipment.

IMPORTANT

Servicing requires extreme care and knowledge of the system and should be performed only by a qualified service technician. For service we suggest you return the tool to your nearest Sears store or repair center. Always use original factory replacement parts when servicing.



WARNING: Do not attempt to operate this tool until you have read thoroughly and understand completely all instructions, safety rules, etc. contained in this manual. Failure to comply can result in accidents involving fire, electrical shock, or serious personal injury. Save the owner's manual and review frequently for continuing safe operation, and instructing others who may use this tool.



READ ALL INSTRUCTIONS

- **KNOW YOUR POWER TOOL.** Read the owner's manual carefully. Learn the saw's applications and limitations as well as the specific potential hazards related to this tool.
- **DO NOT USE IN DANGEROUS ENVIRONMENT.** Do not use power tools near gasoline or other flammable liquids, in damp or wet locations, or expose them to rain. Keep the work area well lit.
- **MAKE WORKSHOP CHILD-PROOF** with padlocks and master switches or by removing starter keys.
- **KEEP CHILDREN AND VISITORS AWAY.** All visitors should wear safety glasses and be kept a safe distance from work area. Do not let visitors contact tool or extension cord while operating.
- **KEEP THE WORK AREA CLEAN.** Cluttered work areas and work benches invite accidents. **DO NOT** leave tools or pieces of wood on the saw while it is in operation.
- **MAINTAIN TOOLS WITH CARE.** Keep tools sharp and clean for better and safer performance. Follow instructions for lubricating and changing accessories.
- **USE THE RIGHT TOOL FOR THE JOB.** Do not force the tool or attachment to do a job it was not designed for. Use it only the way it was intended.
- **DRESS PROPERLY.** Do not wear loose clothing, gloves, neckties, rings, bracelets, or other jewelry. They can get caught and draw you into moving parts. Rubber gloves and nonslip footwear are recommended. Also wear protective hair covering to contain long hair.
- **ALWAYS WEAR SAFETY GLASSES WITH SIDE SHIELDS.** Everyday eyeglasses have only impact-resistant lenses; they are **NOT** safety glasses.
- **NEVER STAND ON TOOL.** Serious injury could occur if the tool is tipped or if the blade is unintentionally contacted.

RULES FOR SAFE OPERATION (Continued)

- **DO NOT OVERREACH.** Keep proper footing and balance at all times.
- **SECURE WORK.** Use clamps or a vise to hold work when practical. It's safer than using your hand and frees both hands to operate tool.
- **USE THE PROPER EXTENSION CORD.** Make sure your extension cord is in good condition. Use only a cord heavy enough to carry the current your product will draw. An undersized cord will cause a drop in line voltage resulting in loss of power and overheating. A wire gage size (A.W.G.) of at least **14** is recommended for an extension cord 25 feet or less in length. If in doubt, use the next heavier gage. The smaller the gage number, the heavier the cord.
- **AVOID ACCIDENTAL STARTING.** Be sure switch is off when plugging in.
- **REMOVE WRENCHES AND ADJUSTING KEYS.** Get in the habit of checking - before turning on tool - that hex keys and adjusting wrenches are removed from tool.
- **CHECK DAMAGED PARTS.** Before using the tool again, check any damaged parts, including guards, for proper operation and performance. Check alignment of moving parts, binding of moving parts, breakage of parts, saw stability, mounting and any other conditions that may affect its operation. A damaged part must be properly repaired or replaced by a qualified service technician at a Sears store or repair center to avoid risk of personal injury.
- **USE ONLY CORRECT BLADES.** Use the right blade size, style and cutting speed for the material and the type of cut. Blade teeth should point down toward the front of the table.
- **USE RECOMMENDED ACCESSORIES.** Using improper accessories may risk injury.
- **USE ONLY SEARS REPLACEMENT PARTS.** All repairs, whether electrical or mechanical, should be made by a qualified service technician at a Sears store or repair center.
- **KEEP GUARDS IN PLACE** and in good working order. This includes the blade guard, riving knife, and anti-kickback pawls.
- **CHECK DIRECTION OF FEED.** Feed work into a blade or cutter against the direction of rotation of the blade or cutter only.
- **DISCONNECT ALL TOOLS.** When not in use, before servicing, or when changing attachments, blades, bits, cutters, etc., all tools should be disconnected from power supply.
- **DO NOT FORCE THE TOOL.** It will do the job better and more safely at the rate for which it was designed.
- **NEVER LEAVE TOOL RUNNING UNATTENDED. TURN THE POWER OFF.** Do not leave tool until it comes to a complete stop.
- **BEFORE MOUNTING, DISCONNECTING OR REMOUNTING THE MOTOR;** unplug the saw and remove the switch key.
- ⚠ **WARNING:** When servicing, use only identical Craftsman replacement parts. Use of any other parts may create a hazard or cause product damage.
- **NEVER USE THIS TOOL IN AN EXPLOSIVE ATMOSPHERE.** Normal sparking of the motor could ignite fumes.
- **MAKE SURE THE WORK AREA HAS AMPLE LIGHTING** to see the work and that no obstructions will interfere with safe operation **BEFORE** performing any work using this tool.
- **DO NOT USE TOOL IF SWITCH DOES NOT TURN IT ON AND OFF.** Have defective switches replaced by a qualified service technician at a Sears store or repair center.
- **GUARD AGAINST ELECTRICAL SHOCK** by preventing body contact with grounded surfaces such as pipes, radiators, ranges, refrigerator enclosures.
- **GROUND ALL TOOLS.** See Electrical page.
- **WEAR A DUST MASK** to keep from inhaling fine particles.
- **PROTECT YOUR HEARING.** Wear hearing protection during extended periods of operation.
- **DO NOT OPERATE THIS TOOL WHILE UNDER THE INFLUENCE OF DRUGS, ALCOHOL, OR ANY MEDICATION.**
- **STAY ALERT AND EXERCISE CONTROL.** Watch what you are doing and use common sense. **Do not operate tool when you are tired. Do not rush.**
- **AVOID AWKWARD OPERATIONS AND HAND POSITIONS** where a sudden slip could cause your hand to move into the blade. **ALWAYS** make sure you have good balance.
- **ALWAYS SUPPORT LARGE WORK PIECES** while cutting to minimize risk of blade pinching and kickback. Saw may slip, walk or slide while cutting large or heavy boards.
- **GUARD AGAINST KICKBACK.** Kickback can occur when the blade stalls, driving the work piece back toward the operator. It can pull your hand into the blade, resulting in serious personal injury. Stay out of the blade path and turn switch off immediately if blade binds or stalls.

RULES FOR SAFE OPERATION (Continued)

- **USE A SUPPORT FOR THE SIDES AND BACK OF THE SAW TABLE** when sawing wide or long workpieces. Use a sturdy “outrigger” support if a table extension is more than 24 inches long and is attached to the saw, to prevent tipping.
 - **CUT ONLY WOOD, PLASTIC OR WOOD-LIKE MATERIALS.** Do not cut metal.
 - **NEVER** cut more than one piece at a time. **DO NOT STACK** more than one workpiece on the saw table at a time.
 - **DO NOT REMOVE THE SAW'S BLADE GUARDS.** Never operate the saw with any guard or cover removed. Make sure all guards are operating properly before each use.
 - **NEVER PERFORM ANY OPERATION FREE-HAND.** Always place the workpiece to be cut on the saw table and position it firmly against the fence as a backstop.
 - **USE THE RIP FENCE.** Always use a fence or straight edge guide when ripping.
 - **BEFORE MAKING A CUT,** be sure all adjustments are secure.
 - **BE SURE THE BLADE PATH IS FREE OF NAILS.** Inspect for and remove all nails from lumber before cutting.
 - **BE SURE THE BLADE CLEARS THE WORKPIECE.** Never start the saw with the blade touching the workpiece.
 - **KEEP HANDS AWAY FROM CUTTING AREA.** Do not reach underneath work or in blade cutting path with your hands and fingers for any reason. Always turn the power off.
 - **USE A PUSHBLOCK OR PUSH STICK** for workpieces so small that your fingers go under the blade guard. **NEVER TOUCH BLADE** or other moving parts during use, for any reason.
-  **WARNING:** Blade coasts after being turned off.
- **ALLOW THE MOTOR TO COME UP TO FULL SPEED** before starting a cut to avoid blade binding or stalling.
 - **ALWAYS PUSH THE WORKPIECE;** never pull it toward the saw.
 - **DO NOT FEED THE MATERIAL TOO QUICKLY.** Do not force the workpiece against the blade.
 - **ALWAYS TURN OFF SAW** before disconnecting it, to avoid accidental starting when reconnecting to power supply. **NEVER** leave the table saw unattended while connected to a power source.
- **BEFORE CHANGING THE SETUP, REMOVING COVERS, GUARDS, OR BLADE;** unplug the saw and remove the switch key.
 - **KEEP TOOL DRY, CLEAN, AND FREE FROM OIL AND GREASE.** Always use a clean cloth when cleaning. Never use brake fluids, gasoline, petroleum-based products, or any solvents to clean tool.
 - **KEEP BLADES CLEAN, SHARP AND WITH SUFFICIENT SET.** Sharp blades minimize stalling and kickback.
 - **USE ONLY OUTDOOR EXTENSION CORDS.** Use only extension cords with the marking “Acceptable for use with outdoor appliances; store cords indoors while not in use.” Use extension cords with an electrical rating not less than the saw’s rating. Always disconnect the extension cord from the outlet before disconnecting the product from the extension cord.
 - **INSPECT TOOL CORDS AND EXTENSION CORDS PERIODICALLY** and, if damaged, have repaired by a qualified service technician at a Sears store or repair center. Stay constantly aware of cord location and keep it well away from the moving blade.
 - **DO NOT ABUSE CORD.** Never yank cord to disconnect it from receptacle. Keep cord from heat, oil, and sharp edges.
 - **SAVE THESE INSTRUCTIONS.** Refer to them frequently and use to instruct other users. If you loan someone this tool, loan them these instructions also.
-  **WARNING:** Some dust created by power sanding, sawing, grinding, drilling, and other construction activities contains chemicals known to cause cancer, birth defects or other reproductive harm. Some examples of these chemicals are:
- lead from lead-based paints,
 - crystalline silica from bricks and cement and other masonry products, and
 - arsenic and chromium from chemically-treated lumber.
- Your risk from these exposures varies, depending on how often you do this type of work. To reduce your exposure to these chemicals: work in a well ventilated area, and work with approved safety equipment, such as those dust masks that are specially designed to filter out microscopic particles.

SAVE THESE INSTRUCTIONS

ELECTRICAL

EXTENSION CORDS

Use only 3-wire extension cords that have 3-prong grounding plugs and 3-pole receptacles that accept the tool's plug. When using a power tool at a considerable distance from the power source, use an extension cord heavy enough to carry the current that the tool will draw. An undersized extension cord will cause a drop in line voltage, resulting in a loss of power and causing the motor to overheat. Use the chart provided below to determine the minimum wire size required in an extension cord. Only round jacketed cords listed by Underwriter's Laboratories (UL) should be used.

Length of Extension Cord	Wire Size (A.W.G.)
Up to 25 feet	14
26-100 feet	12

When working with the tool outdoors, use an extension cord that is designed for outside use. This is indicated by the letters **WA** on the cord's jacket.

Before using an extension cord, inspect it for loose or exposed wires and cut or worn insulation.

⚠ CAUTION: Keep the cord away from the cutting area and position the cord so that it will not be caught on lumber, tools, or other objects during cutting operations.

ELECTRICAL CONNECTION

Your Sears Craftsman Table Saw is powered by a precision built electric motor. It should be connected to a **power supply that is 120 volts, 60 Hz, AC only (normal household current)**. Do not operate this tool on direct current (DC). A substantial voltage drop will cause a loss of power and the motor will overheat. If the saw does not operate when plugged into an outlet, double check the power supply.

SPEED AND WIRING

The no-load speed of your table saw is approximately 3,600 rpm. This speed is not constant and decreases under a load or with lower voltage. For voltage, the wiring in a shop is as important as the motor's horsepower rating. A line intended only for lights cannot properly carry a power tool motor. Wire that is heavy enough for a short distance will be too light for a greater distance. A line that can support one power tool may not be able to support two or three tools.

GROUNDING INSTRUCTIONS

In the event of a malfunction or breakdown, grounding provides a path of least resistance for electric current to reduce the risk of electric shock. This tool is equipped with an electric cord having an equipment-grounding conductor and a grounding plug. The plug must be plugged into a matching outlet that is properly installed and grounded in accordance with all local codes and ordinances.

Do not modify the plug provided. If it will not fit the outlet, have the proper outlet installed by a qualified electrician. Improper connection of the equipment-grounding conductor can result in a risk of electric shock. The conductor with insulation having an outer surface that is green with or without yellow stripes is the equipment-grounding conductor. If repair or replacement of the electric cord or plug is necessary, do not connect the equipment-grounding conductor to a live terminal.

Check with a qualified electrician or service personnel if the grounding instructions are not completely understood, or if in doubt as to whether the tool is properly grounded.

Repair or replace a damaged or worn cord immediately.

This tool is intended for use on a circuit that has an outlet like the one shown in *Figure 1*. It also has a grounding pin like the one shown.

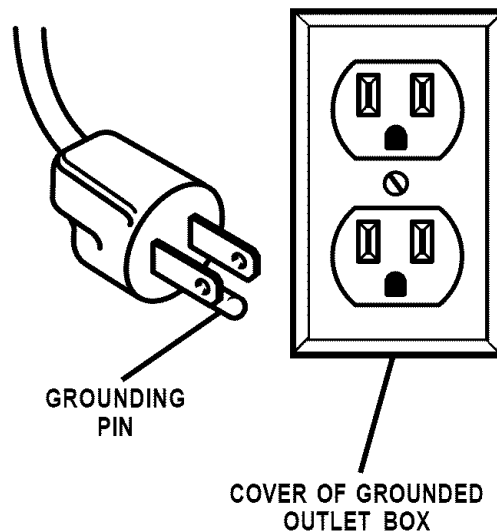

Fig. 1

GLOSSARY OF TERMS FOR WOODWORKING

Anti-Kickback Pawls

Toothed safety devices behind the blade designed to stop a workpiece from being kicked back at the operator during a ripping operation.

Arbor

The shaft on which a blade or cutting tool is mounted.

Bevel Cut

A cutting operation made with the blade at any angle other than 90° to the saw table.

Compound Cut

A cut with both a miter angle and a bevel angle.

Crosscut

A cutting operation made across the grain or the width of the workpiece.

Dado

A non-through cut that gives a square notch or trough; requires a special blade.

Featherboard

A device to help guide workpieces during rip cuts.

Freehand (for table saw)

Dangerous practice of making a cut without using rip or miter fences. See Safety Rules.

Gum

A sticky, sap-based residue from wood products.

Heel

Alignment of the blade.

Kerf

The material removed by the blade in a through cut or the slot produced by the blade in a non-through cut.

Kickback

A hazard that can occur when blade binds or stalls, throwing workpiece back toward operator.

Leading End

The end of the workpiece pushed into the cutting tool first.

Miter Cut

A cutting operation made with the miter gage at any angle other than 0°.

Molding

A non-through cut that gives a varied shape to the workpiece and requires a special blade.

Push Stick

A device used to feed the workpiece through the saw blade during narrow cutting operations. It helps keep the operator's hands well away from the blade.

Rabbet

A notch in the edge of a workpiece.

Resaw

A cutting operation to reduce the thickness of the workpiece in order to make thinner pieces.

Resin

A sticky, sap-based substance.

Rip Cut

A cut made with the the grain of the workpiece.

Sawblade Path

The area directly in line with the blade — over, under, behind, or in front of it. Also, the workpiece area which will be or has been cut by the blade.

Set

The distance that the tip of the saw blade tooth is bent (or set) outward from the face of the blade.

Throw-Back

Saw throwing back a workpiece; similar to kickback.

Through Sawing

Any cutting operation where the blade extends completely through the workpiece.

Trailing End

The workpiece end last cut by the blade in a rip cut.

Workpiece

The item on which the cutting operation is being done. The surfaces of a workpiece are commonly referred to as faces, ends, and edges.

Worktable

The surface on which the workpiece rests while performing a cutting operation.

PRODUCT SPECIFICATIONS

Blade Arbor	5/8 in.	Rating	13 Amperes, 1.5 HP (3 HP max. developed)
Blade Diameter	10 in.	Input	120 V, 60 Hz - AC only
Blade Tilt	0° - 45°	No Load Speed	3,600 RPM
Table Size without table extensions	20 in. x 27 in.	Cutting Capacity with Miter at 0°/Bevel 0°	3-3/8 in.
Table Size with table extensions	44 in. x 27 in.	Cutting Capacity with Miter at 0°/Bevel 45°:	2-1/4 in.

UNPACKING

Your new table saw has been designed to give you many years of high quality performance. To insure this goal, proper care and treatment is important. Careful treatment begins with removing all parts from the carton and checking them against the list of loose parts. The long box contains the rails. The large box holds all other parts, which are detailed in the *Loose Parts List*.

- Separate the saw and all parts from the packing materials and check each against the packing list, especially the small parts that can be hidden in the packing material.

Note: Do not discard the packing materials until you have carefully inspected the saw, identified all parts, and satisfactorily operated your new saw.

 **WARNING:** Never use gasoline, naphtha, or other highly volatile solvents. Do not ever let brake fluids, gasoline, petroleum-based products, or penetrating oils contact plastic parts. Such chemicals can weaken or destroy plastic.

- Remove the wax paper covering on the table. Use any ordinary household type grease and spot remover. Immediately apply a coat of paste wax to the table and table extensions.

 **WARNING:** To prevent accidental starting that could cause possible serious personal injury, assemble all parts to your saw before connecting it to power supply. Saw should never be connected to power supply when you are assembling parts, making adjustments, installing or removing blades, or when not in use.

 **WARNING:** If any parts are missing, do not operate this tool until the missing parts are replaced. Failure to do so could result in possible serious personal injury.

ACCESSORIES

The following recommended accessories are currently available at Sears Retail Stores.

- Fence Guide System
- Guide Master
- Box Joint & Miter Guide
- Universal Jig
- Taper Jig
- 10 in. Sanding Disc
- 8 in. Sanding Disc
- Elite Dado
- Excalibur Dado
- 7 in. Adj. Dado 36 tip
- 7 in. Adj. Dado 24 tip
- 7 in. Stack Steel Dado
- 7 in. x 9/16 in. Stack Dado
- 7 in. Molding Head Set
- 2 Bit Molding Head Set
- Saw Baskets
- Jointer Clamps
- Specialty Throat Plate
- Miter Gage Hold Down Clamp
- Align-A-Rip XRC Rip Fence
- Dust Collection System
- Accessory Table

 **WARNING:** The use of attachments or accessories not listed might be hazardous.

LOOSE PARTS LIST

The following items are included with your Table Saw.

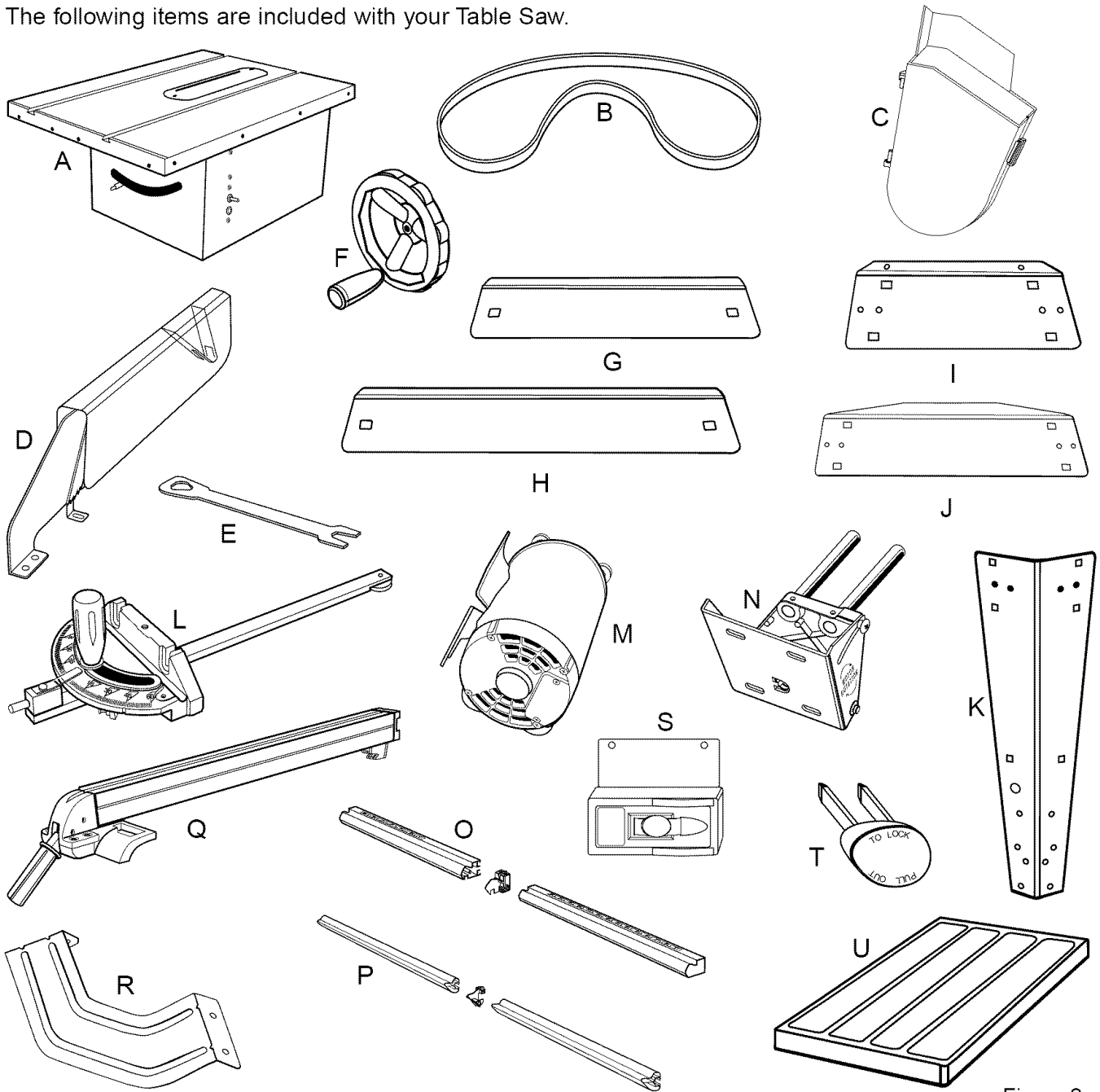

Figure 2 a

A. Table Saw Base	1	O. Rail, Front (Hardware Shown Separately)	1
B. Belt	1	P. Rail, Rear (Hardware Shown Separately)	1
C. Belt Guard	1	Q. Rip Fence	1
D. Blade Guard Assembly (Hardware Shown Separately)	1	R. Blade Guard Bracket	1
E. Wrench	1	S. Switch Assembly	1
F. Handwheel (Hardware Shown Separately)	2	T. Switch Key	1
G. Leg Brace, lower (short)	2	U. Table Extension	2
H. Leg Brace, lower (long)	2	V. Hardware for Mounting Motor, Motor Mounting Plate, and Belt Guard (Shown Separately)	1
I. Leg Brace, upper (short)	2	W. Hardware for Table Extensions (Shown Separately)	1
J. Leg Brace, upper (long)	2	X. Hardware for Leg Stand, Leveling Feet, and Mounting Saw Base (Shown Separately)	1
K. Leg	4	Y. Hardware for Blade Guard Bracket and Blade Guard Assembly (Shown Separately)	1
L. Miter Gage	1	Z. Owner's Manual (Not Shown)	1
M. Motor	1		
N. Motor Mounting Plate (Hardware Shown Separately)	1		

SMALL PARTS LIST

Check all loose parts from the box with the list on the previous page, the figures below and on the following page. Small items such as fasteners and end caps are shown in figures 2 b and 2 c. Follow the instructions in the Assembly section to assemble your new saw.

- F. Hardware for Handwheel 2
 screw (#10-24 x 1/2 in.) 2
 flat washer (#10) 2

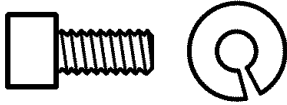

- V. Hardware for Mounting Motor, Motor Mounting Plate, and Belt Guard 1
 Hardware for Mounting Motor 1
 hex bolt (5/16-18 x 1 in.) 4
 flat washer (5/16 in.) 8
 lock washer (5/16 in.) 4
 hex nut (5/16-18) 4



- Hardware for Motor Mounting Plate 1
 hex bolt (5/16-18 x 3/4 in.) 2

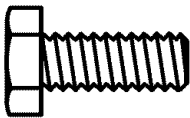

- Hardware for Belt Guard 1
 hex nut (#10-24) 4
 flat washer (#10) 4



- W. Hardware for Table Extensions 1
 hex bolt (5/16-18 x 1 in.) 8
 flat washer (5/16 in.) 16
 hex nut (5/16-18) 8

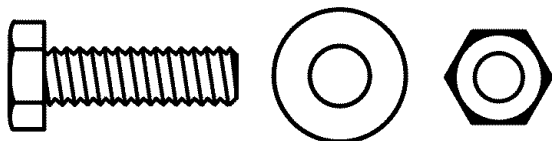

- X. Hardware for Leg Stand, Leveling Feet, and Mounting Saw Base 1
 Hardware for Leg Stand 1
 carriage bolt (5/16-18 x 3/4 in.) 24
 flat washer (5/16 in.) 24
 hex nut (5/16-18) 24

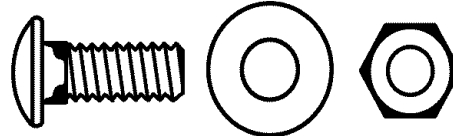

- Hardware for Leveling Feet 1
 leveling foot 4
 flat washer (5/16 in.) 8
 hex nut (5/16-18) 8

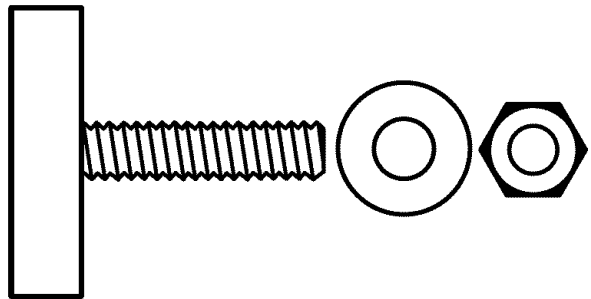

- Hardware for Mounting Saw Base 1
 hex bolt (5/16-18 x 3/4 in.) 4
 flat washer (5/16 in.) 8
 hex nut (5/16-18) 4

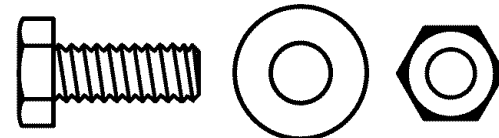
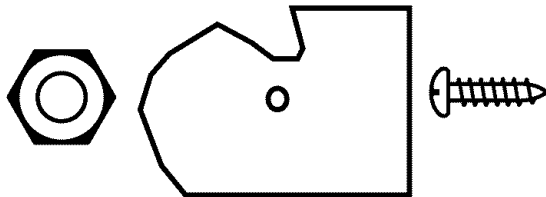
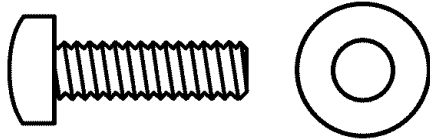

Fig. 2 b

SMALL PARTS LIST

Check all loose parts from the box with the list and figures below and on the previous pages. Small items such as fasteners and end caps are shown in figure 2 c. Follow the instructions in the *Assembly* section to assemble your new saw.

O. Hardware for Rail, Front	1
square head bolt (5/16-18 x 1 in.)	6
flat washer (5/16 in.)	6
hex nut (5/16-18)	6
end cap for front rail	2
screw (#8-32 x 1/2 in.)	2



P. Hardware For Rail, Rear	1
square head bolt (5/16-18 x 1 in.)	6
flat washer (5/16 in.)	6
hex nut (5/16-18)	6
end cap for rear rail	2
screw (#8-32 x 1/2 in.)	2

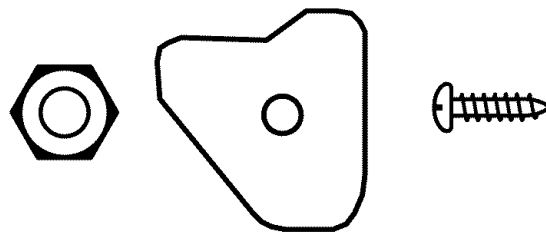
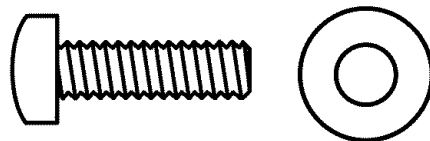

Y. Hardware for Blade Guard Bracket and Blade Guard Assembly	1
Blade Guard Bracket	1
hex cap screw (5/16-18 x 1/2 in.)	2
lock washer (5/16 in.)	2



Blade Guard Assembly	1
socket head cap screw (1/4-20 x 3/8 in.)	3
flat washer (1/4 in.)	3



M. Hardware for Mounting Switch Assembly	1
square nut (1/4-20)	2
screw (1/4-20 x 3/8 in.)	2
screw (#10-24 x 3/8 in.)	2
cord clip	2

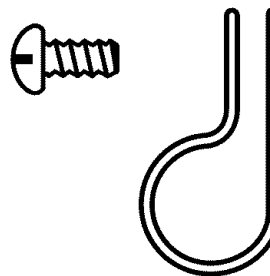
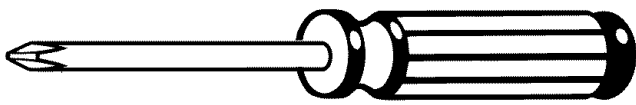

Fig. 2 c

Note: Cord clip and screw mount to the either side of saw cabinet and are used to secure motor cord, depending upon operator preference of switch assembly.

TOOLS NEEDED

The following tools are needed for assembly and alignment. **Note:** The five hex keys listed below have been provided with your saw. The remaining tools are typical shop tools and are not included with your saw.



SMALL / MEDIUM
PHILLIPS SCREWDRIVER

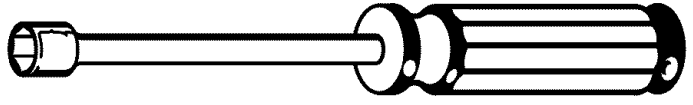

NUT DRIVER
8 mm, 10 mm, and 12 mm

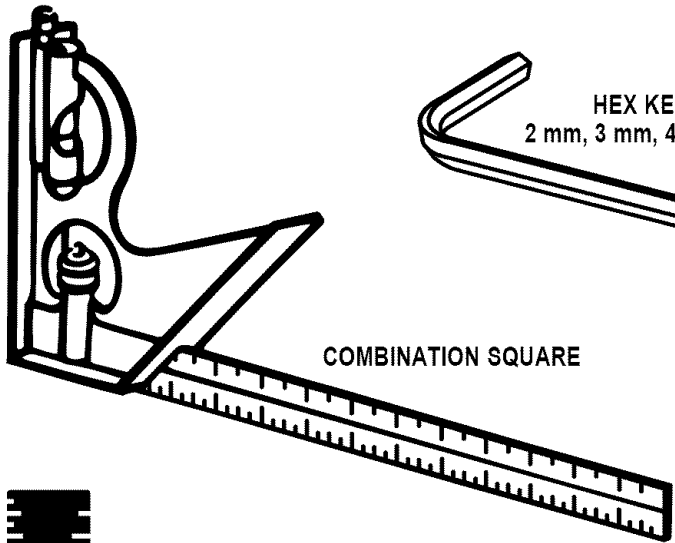

COMBINATION SQUARE

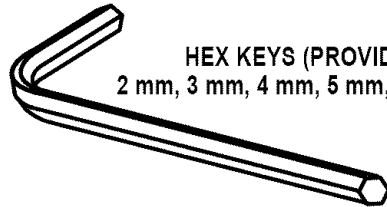

HEX KEYS (PROVIDED)
2 mm, 3 mm, 4 mm, 5 mm, and 6 mm

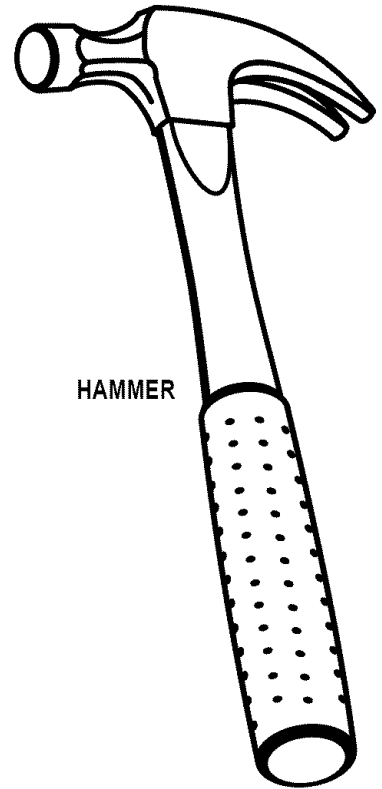

HAMMER

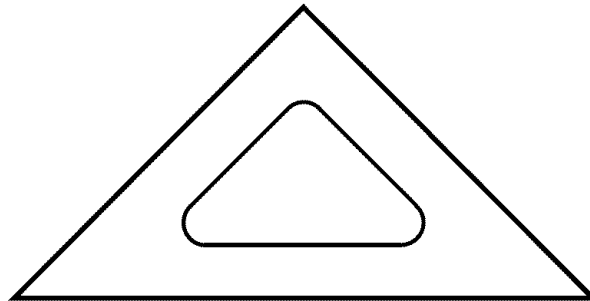

45° TRIANGLE

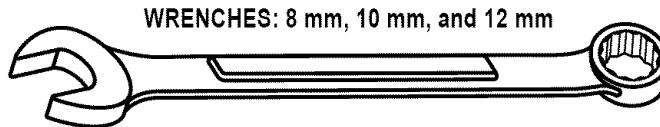

WRENCHES: 8 mm, 10 mm, and 12 mm

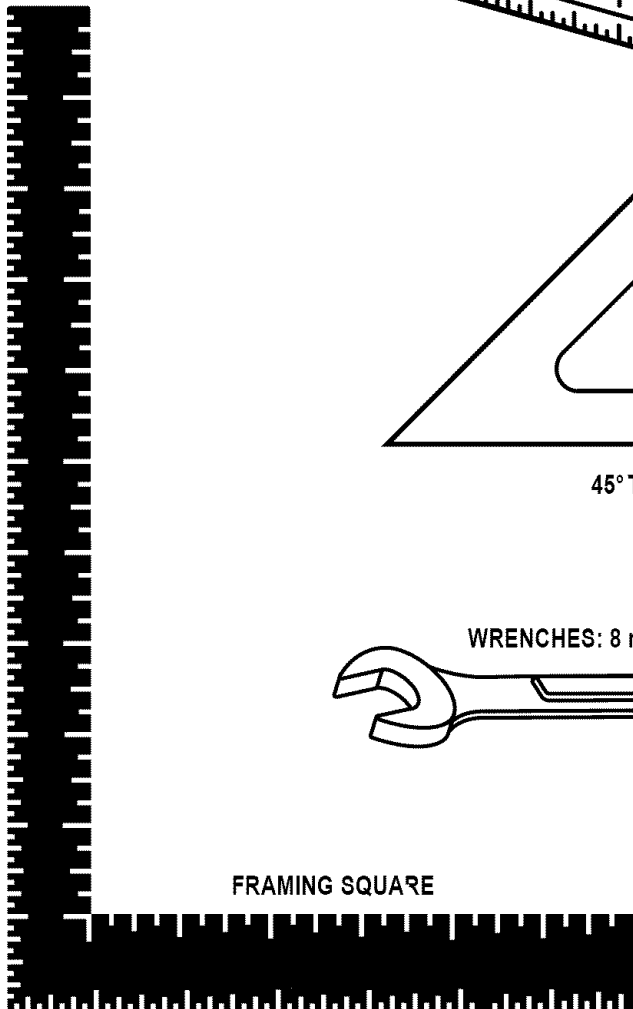

FRAMING SQUARE

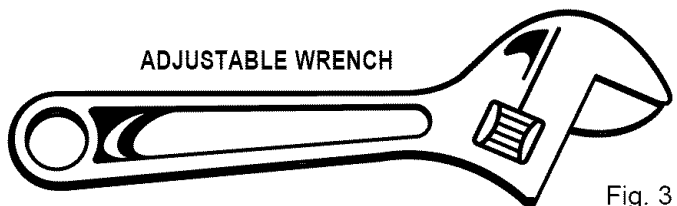

ADJUSTABLE WRENCH

Fig. 3

LABELS

The following labels are found on your saw in the locations shown. Read all warnings and this owner's manual before using saw.

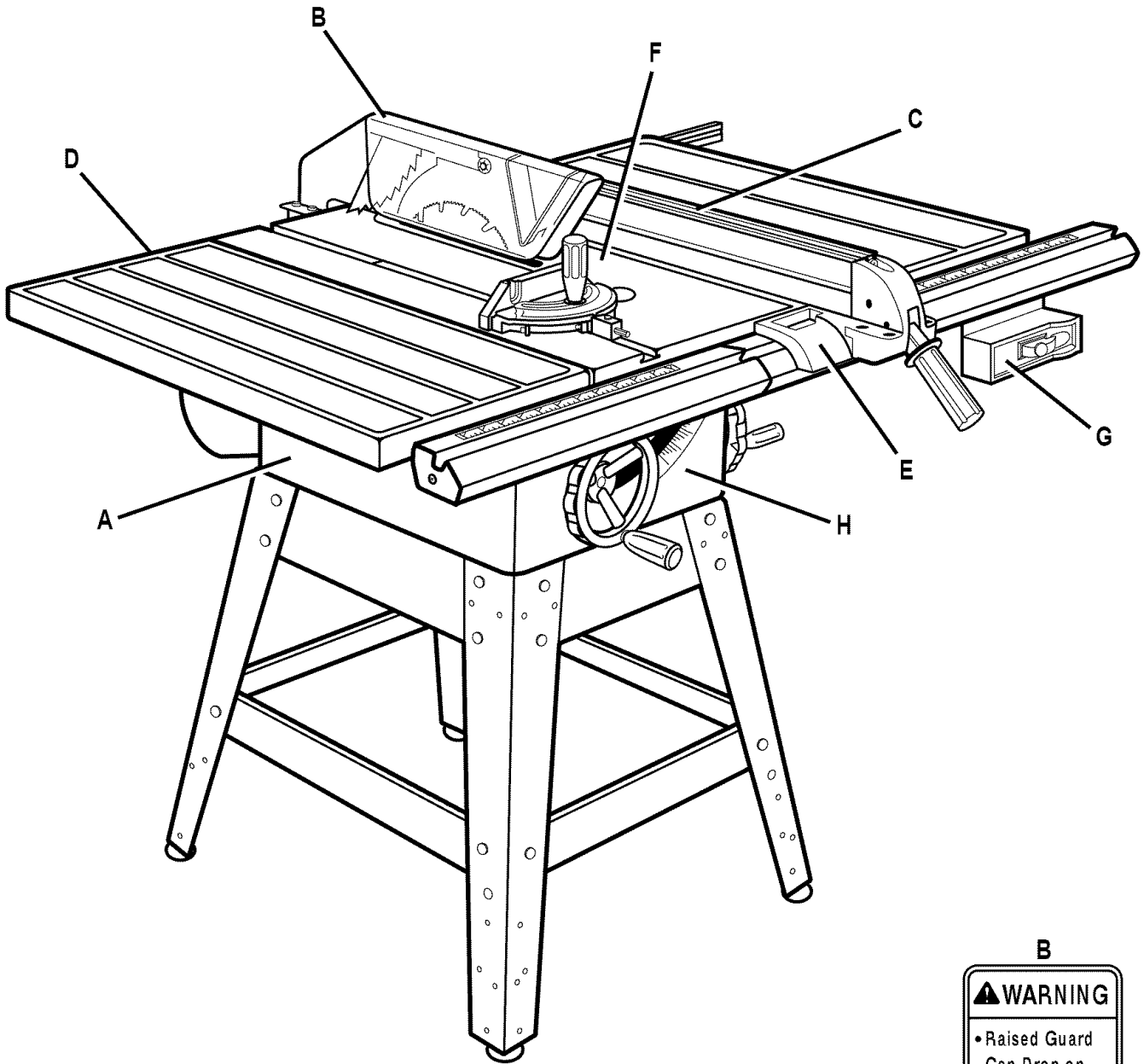

A

10 inch Table Saw
3600 R.P.M. 120 VOLTS 60 Hz AC ONLY 13 A

⚠ WARNING

WHEN SERVICING, USE ONLY IDENTICAL CRAFTSMAN REPLACEMENT PARTS.

LR63420



US
STATIONARY TOOL

MODEL 315.228390
MADE IN TAIWAN
SEARS, ROEBUCK AND CO.

SER. NO.

Customer Help Line 1-800-932-3188

B

⚠ WARNING

- Raised Guard Can Drop on Spinning Blade and Break.
- To reduce The Risk of Injury, Guard Must be in Place During Use.
- Align and Tighten Riving Knife Fasteners Before Use

LABELS

⚠ WARNING

When Mounting an Auxiliary Fence Face, Position Mounting Hardware Beyond Arrow at Right and Left as Indicated.
Keep Fasteners Away From Blade.

D

**Do Not Lift Saw With Rails
or Extension Tables.**

E

⚠ WARNING

Debris on rail can misalign the rip fence. Workpiece could bind or suddenly kick back. You could be hit or cut. Clean debris off fence rail before positioning fence.

F

⚠ WARNING

- Attach Blade Guard Assembly Before Operating this Saw
- Read Owners Manual

G

PULL ON

PUSH OFF

H

Turn Clockwise to Raise Blade.
Counterclockwise to Lower Blade.

Turn Clockwise to Increase Blade Angle.



⚠ WARNING

- Read manual before using saw.
- Wear safety goggles that meet ANSI Z87.1 standards.
- Do not reach around or over saw blade.
- Keep blade guard down and in place for through cuts.
- Do not make freehand cuts. Keep hands out of path of saw blade.
- When ripping, use push stick when fence is set 2 inches or less from blade.
- Know how to reduce the risk of kickback. See instructions for ripping.
- When ripping, use push block and auxiliary fence when fence is set between 1/2 and 2 inches from blade.
- Do not make rip cuts narrower than 1/2 inch.
- Turn power off and wait for blade to stop before adjusting or servicing.

FEATURES

KNOW YOUR TABLE SAW

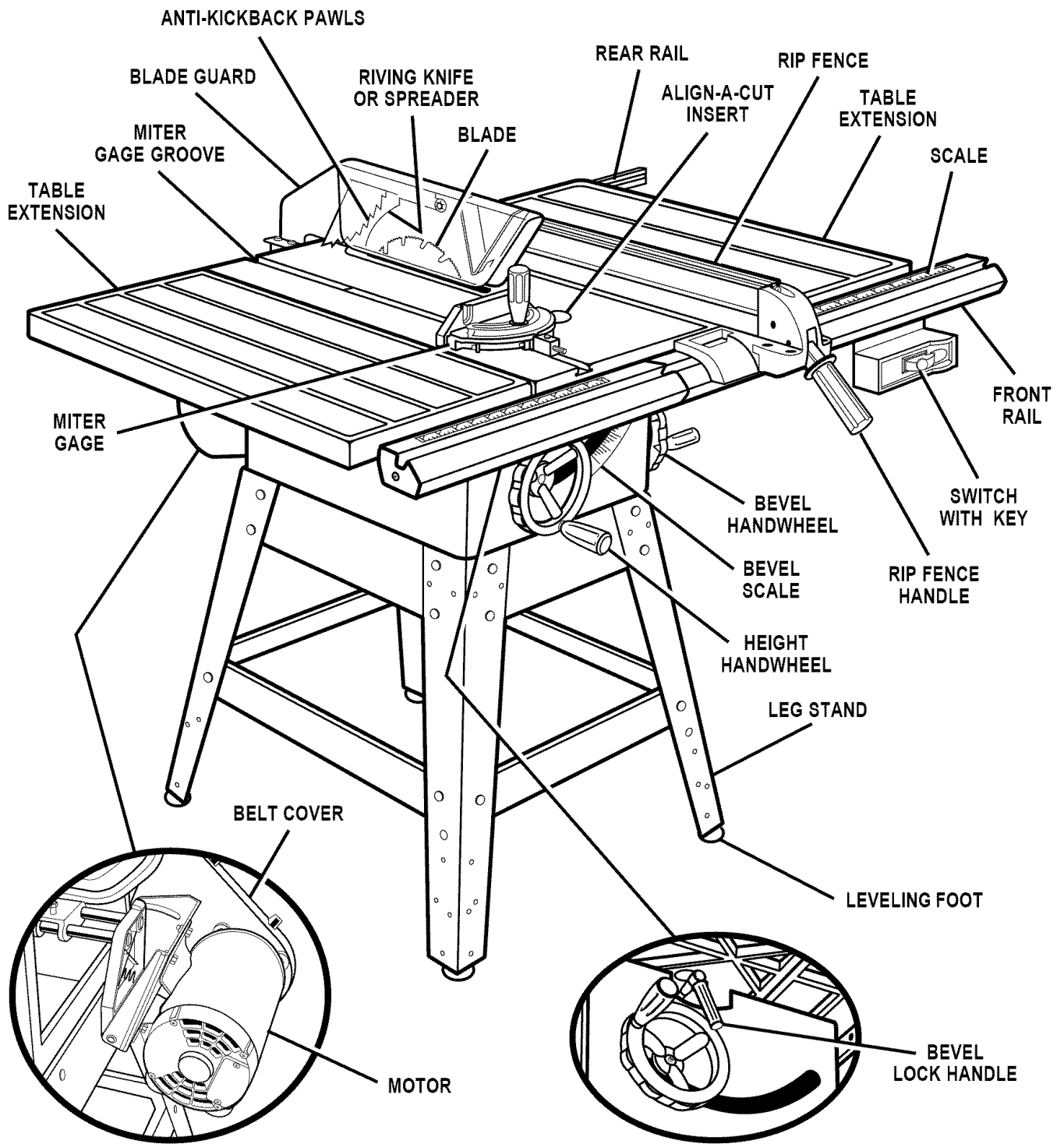

Fig. 5

FEATURES

OVERVIEW

The upper portion of the blade projects up through the table, surrounded by an insert called the throat plate. The height of the blade is set with a handwheel on the front of the cabinet. To accommodate wide panels, the tabletop has extensions on each side. Detailed instructions are provided in the *Operation* section of this manual for the basic cuts: cross cuts, miter cuts, bevel cuts, and compound cuts.

For cuts with the blade straight up and cutting across the grain (cross cuts or miter cuts), use the miter gage to set the angle and push the wood into the blade. To cut with the blade straight up, along the grain of the wood (rip cuts), use the rip fence to guide the wood. Push smaller pieces with a pushblock or pushstick.

To tilt the blade for a bevel cut, use the bevel handwheel on the side of the cabinet. A bevel scale on the front of the cabinet shows the blade angle. Inside the cabinet, adjustable positive stops control the degree of tilt.

Use the miter gage with a bevel cross cut (compound cut) and the rip fence with a bevel rip cut. Other cuts require special attachments, which have detailed instructions to reduce risk of injury and ensure the best performance from your new saw.

Before attempting to use your saw, familiarize yourself with all operating features and safety requirements of your Sears Craftsman table saw. The saw's features are described below.

ALIGN-A-CUT INSERT - A plastic insert on which marks may be made to indicate the location of the sawcut on the workpiece.

ANTI-KICKBACK PAWLS - Kickback is a hazard in which the workpiece is thrown back toward the operator. The toothed pawls are designed to snag the workpiece to prevent or reduce injury should kickback occur.

BEVEL HANDWHEEL - This handwheel, on the right side of the cabinet, tilts the blade for a bevel cut.

BEVEL SCALE - The easy-to-read scale on the front of the workstand shows the exact blade angle.

BLADE - This saw is provided with a Craftsman 64 tooth, 10 in. steel blade. The blade is adjusted with bevel and height handwheels on the cabinet. Bevel angles are locked with a handle below the front rail.

 **WARNING:** Be sure to use only blades rated for at least 5,000 rpm and recommended for use on this saw. Check with your nearest Sears retail store.

BLADE GUARD - Always keep the guard down over the blade for through-sawing cuts.

BEVEL LOCK HANDLE - This handle, placed just under the worktable surface on the front of the cabinet, locks the angle setting of the blade. Be sure the handle is hanging straight down before tilting the blade. If it is not straight down, it may jam and bend the locking bolt.

HEIGHT HANDWHEEL - Use this handwheel to lower and raise the blade for adjustments or replacement. It is located on the front of the cabinet.

MITER GAGE - This gage aligns the wood for a crosscut. The easy-to-read indicator shows the exact angle for a miter cut, with positive stops at 90° and 45°.

MITER GAGE GROOVES - The miter gage rides in these grooves on either side of the blade.

MITER GAGE KNOB - Located on the miter gage, this knob locks in the cutting angle after selection.

MOTOR (13 AMP) - The powerful induction motor is 1.5HP (3HP maximum developed), with capacitor start and V-belt drive, and is housed in a sturdy steel base.

RAILS - Front and rear rails provide support for large workpieces and the rip fence.

RIP FENCE - A sturdy metal fence guides the workpiece and is secured with the rip fence handle. Grooves run along the top and sides of the rip fence for use with optional clamps and accessories.

RIP FENCE HANDLE - The handle on the front of the rip fence releases the rip fence or locks it in place.

RIVING KNIFE OR SPREADER - Located directly behind the blade, it keeps cut edges from binding and supports the blade guard.

SCALE - Found on the front rail, the easy-to-read scale provides precise measurements in rip cuts.

SWITCH WITH KEY - Your table saw has an easy access power switch located below the front rail. The yellow switch key must be removed from the hardware bag and inserted into the switch before saw can be operated. To lock the switch in the **OFF** position, remove the switch key from the switch. Place the key in a location that is inaccessible to children and others not qualified to use the tool.

TABLE EXTENSIONS - Removable stamped steel extensions, 12 in. by 27 in., support larger workpieces.

ASSEMBLY

Assembly is best done in the area where the saw will be used. When you remove the table saw base, loose parts, and hardware from the packing materials, check all items with the loose parts list and drawing. If you are unsure about the description of any part, refer to the drawing. If any parts are missing, delay assembling until you have obtained the missing part(s).

INSTALLING HANDWHEELS ON TABLE SAW BASE

See Figure 6.

- Each handwheel bag contains a handwheel, a screw (#10-24 x 1/2 in.), and a flat washer (#10).
- Align handwheels to the shaft ends that extend from the front and right side of the table saw base. Match the flat spots on the shaft and inside the handwheel. Insert a screw and a flat washer in the handwheel center and tighten with a 4 mm hex key.

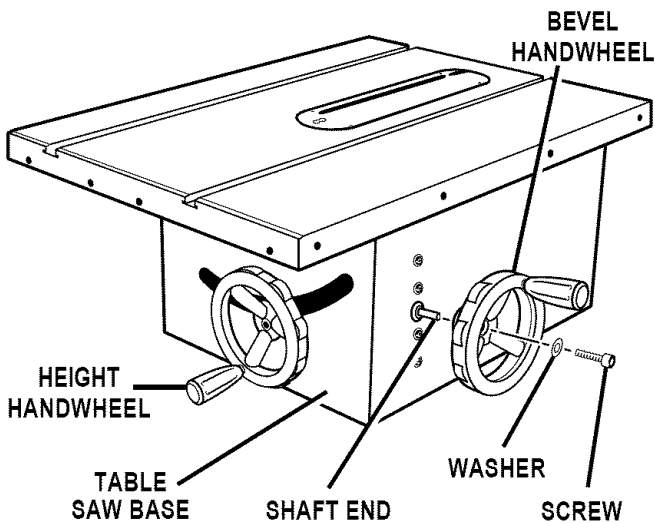

Fig. 6

Note: If you do not use the leg stand and mount the saw table base on a bench instead of the legs, go to the procedure for *Assembling Table Extensions*. Be sure the bench surface has an opening for sawdust to fall through. The opening should be as large as the opening in the bottom of the saw table base. A height of 36 inches from the top of the saw table to the floor is recommended.

ASSEMBLING LEG STAND

See Figures 7 and 8.

- Take from the leg stand hardware bag the following:

- 24 carriage bolts (5/16-18 x 3/4 in.)
- 32 flat washers (5/16 in.)
- 32 hex nuts (5/16-18)
- 4 leveling feet

Note: Remaining hardware from this bag is used for mounting leg stand on the table saw base.

- Take 4 legs and 8 braces from loose parts.
- Place a short upper brace inside two of the legs, with the legs wide end up. (Upper braces have two large holes in each end.) Make sure the two dimples on the leg align with the two small holes on each brace.

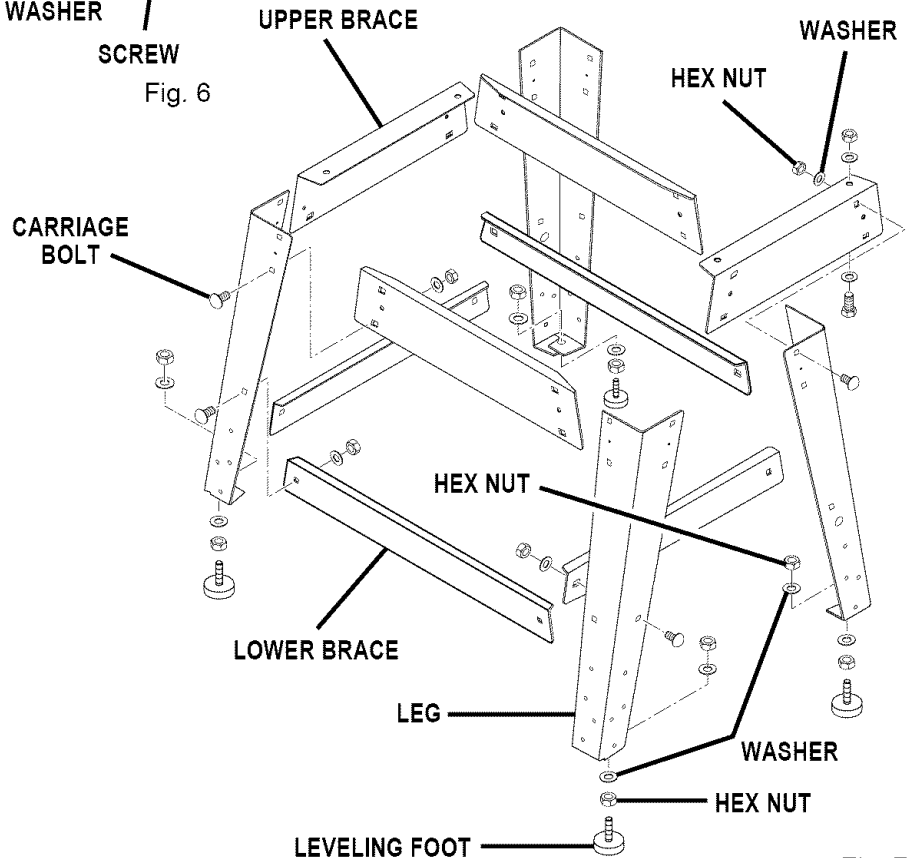
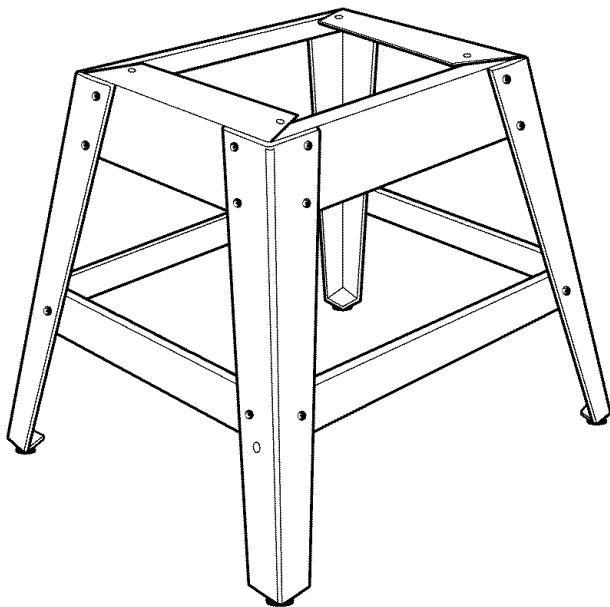

Fig. 7

ASSEMBLY

ASSEMBLING LEG STAND (Continued)

- Align the two large holes on the brace and the legs. Insert the carriage bolts. Add flat washers and hex nuts and hand tighten. Repeat for the other short upper brace. These are the front and back sets.
- For the sides, install a long upper brace on two legs. Add hardware and finger tighten. Repeat for the other long upper brace.
- Use the same steps to install the lower braces. Tighten all hex nuts with a 12 mm wrench.
- Place a hex nut and flat washer on each leveling foot. Install the leveling feet from the bottom of each leg with the bolts pointing up. Secure with a flat washer and hex nut but do not tighten.
- Move the leg stand to desired location. Adjust the leveling feet with a 12 mm wrench, then securely tighten the top hex nut.



LEG STAND SHOWN ASSEMBLED Fig. 8

MOUNTING THE LEG STAND ON THE TABLE SAW BASE

See Figure 9.

- Take the following from the hardware bag:
 - 4 hex bolts (5/16-18 x 3/4 in.)
 - 4 hex nuts (5/16-18)
 - 8 flat washers (5/16 in.)

Note: This hardware was in the bag with hardware for assembling the leg stand and leveling feet.

- Place the saw table upside down on a smooth surface, such as cardboard, on the floor.

WARNING: Do not lift the saw table without help. The table saw base weighs approximately 95 lbs. Hold it close to your body. Keep your knees bent and lift with your legs, not your back. Ignoring these precautions can result in back injury.

- Place the leg stand on the table saw base. Align the holes in the table with the holes in the end braces. Make sure the Craftsman label faces the front of the saw (same side as height handwheel).
- Place a flat washer on each bolt and insert through hole. Add a flat washer and a hex nut. Hand tighten.
- Repeat for the three remaining holes. Tighten all hardware with a 12 mm wrench. You may find it helpful to use two wrenches, one wrench to hold the head of the bolt and one to tighten the hex nut. Leave the saw upside down to add table extensions.

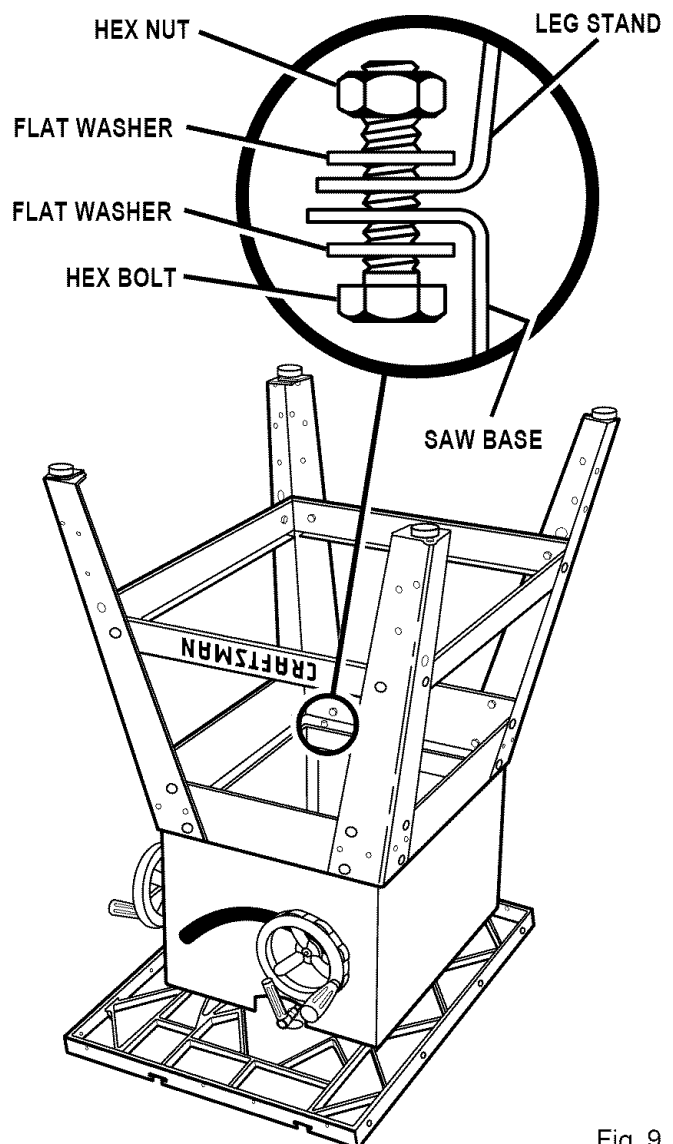

Fig. 9

ASSEMBLY

ASSEMBLING TABLE EXTENSIONS

See Figure 10.

- Locate the table extensions and the small hardware bag with the following:

8 hex bolts (5/16-18 x 1-1/4 in.)

8 hex nuts (5/16-18)

16 flat washers (5/16 in.)

- ⚠ **WARNING:** The table extensions not only provide a support for large or wide pieces of material, but help protect you. Serious injury can result from workpiece binding or kickback due to twisted rails or a misaligned rip fence.

- With the saw upside down, align table extensions to the saw table. Put a flat washer on each bolt, and attach the extensions to the table by inserting bolts through holes from the direction of the table.
- Slip the remaining flat washers and hex nuts on the bolts. Lightly tighten with a 12 mm wrench.

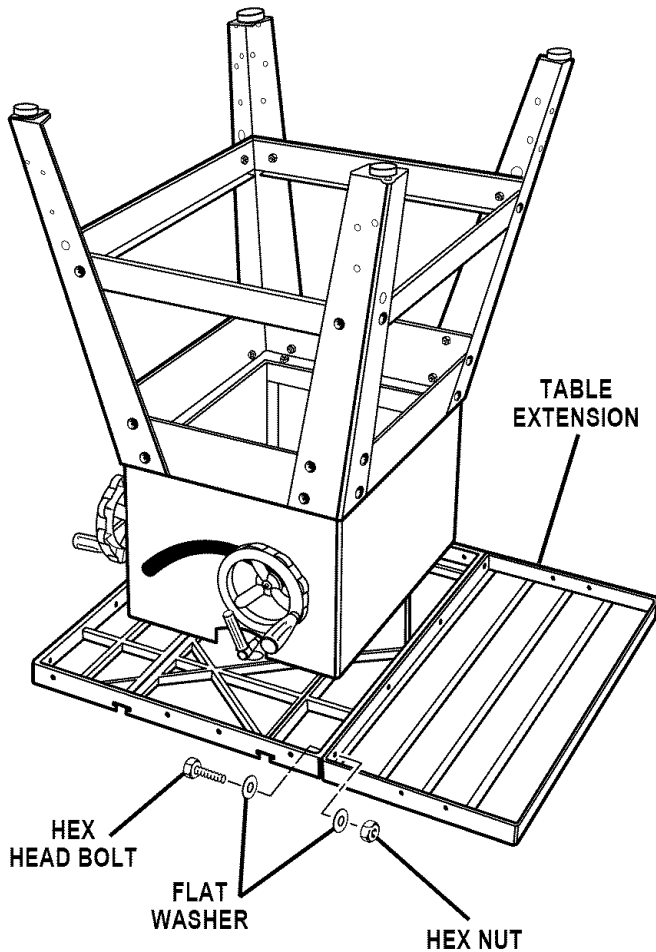

Fig. 10

- Get help to stand saw assembly upright using the center saw table. Do not grasp saw by extensions.

- ⚠ **WARNING:** Do not lift the saw table without help. Hold it close to your body. Keep your knees bent and lift with your legs, not your back. Ignoring these precautions can result in back injury.

ALIGNING TABLE EXTENSIONS

See Figure 11.

A good alignment allows the rails to slide on easily.

- Stand at the front of the saw and line up the front edges of the saw table and extensions.
- Pull the extensions out slightly, put a block of wood where the extension meets the table, and tap the block of wood with a hammer. Check and repeat until the front edges are even.
- Lift each extension slightly until it is higher than table (if necessary, place a block below and tap upward). Center the block of wood over the front and rear edges and tap it until both are even (flush) with saw table. Recheck the front alignment. If even, tighten the screws with a 12 mm wrench.

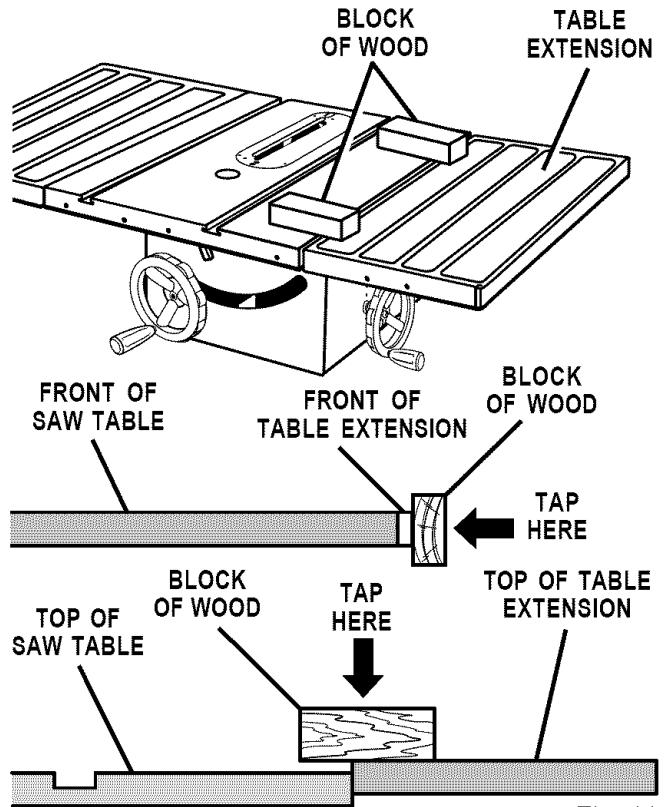

Fig. 11

SPLIT RAIL DESIGN

Your saw has a split rail design. The front and rear rails each have a left and right piece that must be installed. They are joined together on your saw with a connector. We suggest that you install the right rear and right front pieces first. Align and secure these pieces, then use the connectors provided to secure left rear and left front pieces.

ASSEMBLY

Note: The right side of saw is on your right when facing the saw, as if you were in normal operating position.

INSTALLING THE REAR RAIL

See Figures 12 – 14.

WARNING: Front and rear rails must be installed and carefully aligned to reduce the risk of kickback. Kickback can result in serious injury.

From the carton, remove the rear rail pieces and the following hardware:

- 6 square head bolts (5/16-18 x 1 in.)
- 6 flat washers (5/16 in.)
- 6 hex nuts (5/16-18)
- Rear rail connector
- Right and left end caps for rear rail
- 2 screws (#8-32 x 1/2 in.)

Note: Remaining hardware from this hardware bag is used for installing the front rail and end caps.

- At the back of the table, put the square head bolts in the holes in the edge of the saw table and the outer holes in each extension table so the bolt heads extend outward 1/2 in.
- Under the table, loosely attach washers and hex nuts onto bolts. Slide the slot on the rear rail over the bolts. Adjust each bolt to fit the rail closely to the table.
- Position right rail (longest piece) so that right hand edge extends 2-1/2 inches beyond table extension.
- Push right rail against table and tighten each nut with a 12 mm wrench. If rail jams and does not slide easily over bolts, re-align table extensions.
- Put the end caps on rail ends. Insert the screws and tighten with a phillips head screwdriver.

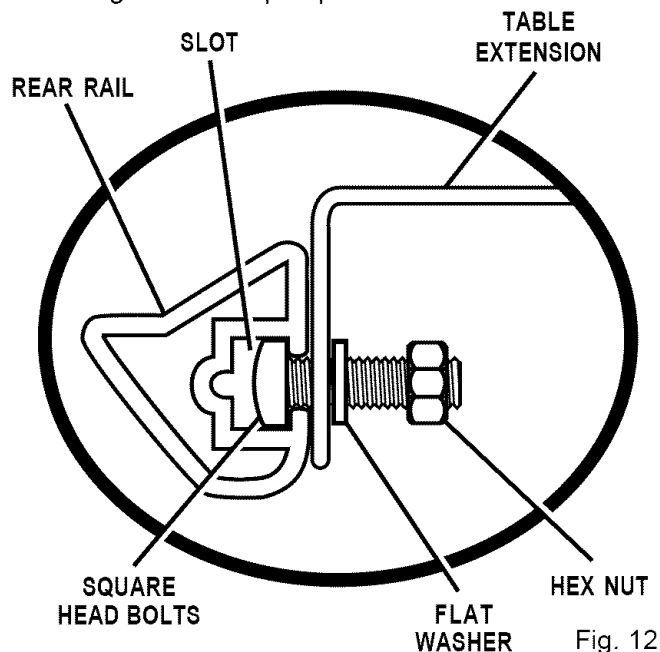

Fig. 12

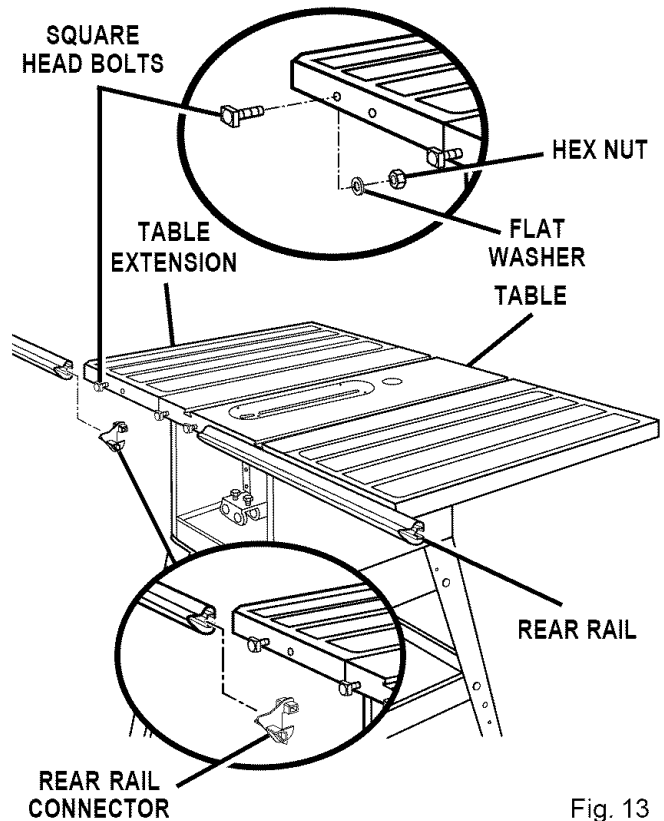

Fig. 13

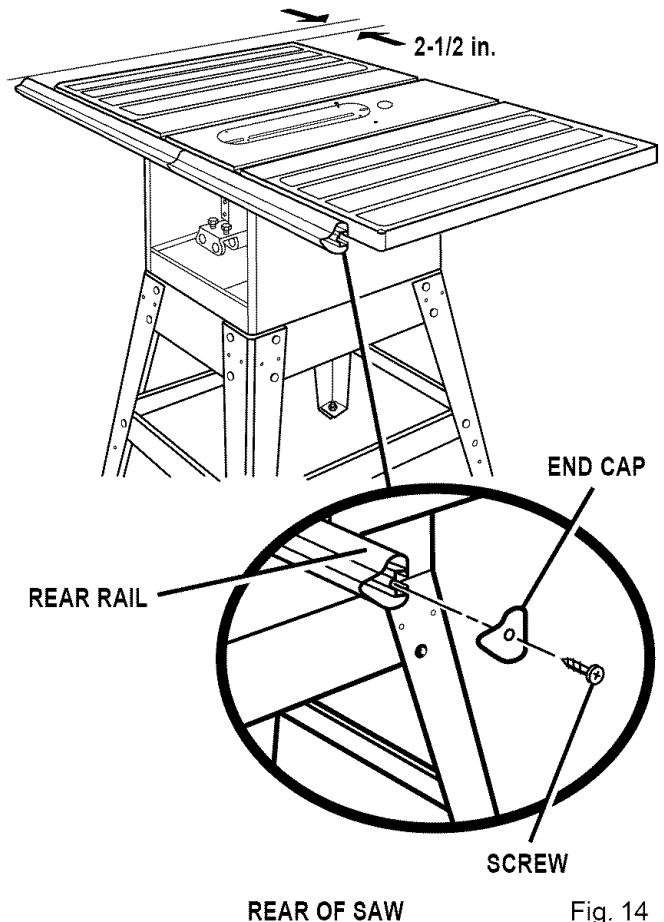

Fig. 14

ASSEMBLY

INSTALLING THE FRONT RAIL

See Figures 15 and 16.

- Get the front rail pieces, the switch assembly, and the following hardware:

- 6 square head bolts (5/16-18 x 1 in.)
- 6 flat washers (5/16 in.)
- 6 hex nuts (5/16-18)
- 2 screws (1/4-20 x 3/8 in.) (located on switch plate)
- 2 square nuts (1/4-20) (located on switch plate)
- Front rail connector
- Right and left end caps for front rail
- 2 screws (#8-32 x 1/2 in.)

- Set aside end caps and screws until you have aligned the rip fence and front rail.
- Insert the six square head bolts into the table and extensions, so the bolt heads extend outward 1/2 in.
- Loosely attach a washer and a hex nut to each bolt.
- The back of the rail has two slots. Slide the upper slot over the bolts. (Bottom slot is for switch.)
- Align the right rail from left to right – Match the 7-1/8 in. mark on the right scale to the right edge of the table saw base (main table). See Figure 16.
- Snug right rail against table. Finger-tighten each nut on the table and extensions.
- Locate the switch assembly. The two screws are installed through the back of the switch plate with the square nuts extending out toward the front.

Note: The square nuts are loose on the switch plate.

- Slide the square nuts into the lower slot of the rail.
- Slide the switch assembly to a convenient position, leaving ample clearance for the handwheel. Tighten securely with a screwdriver. Do not tighten the rail bolts.
- Attach the end caps and screws with a phillips screwdriver.

⚠ WARNING: Place the switch out of the immediate work area to avoid accidentally turning it off during operation.

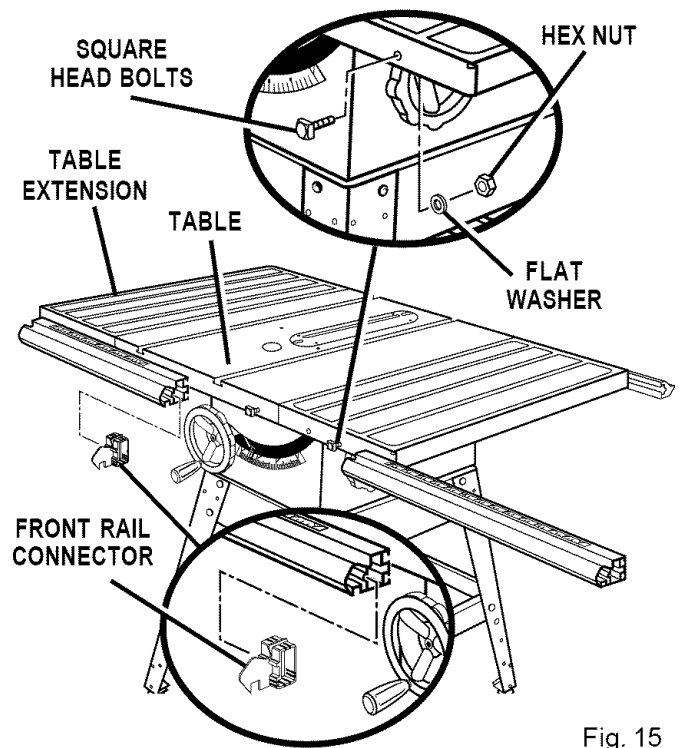

Fig. 15

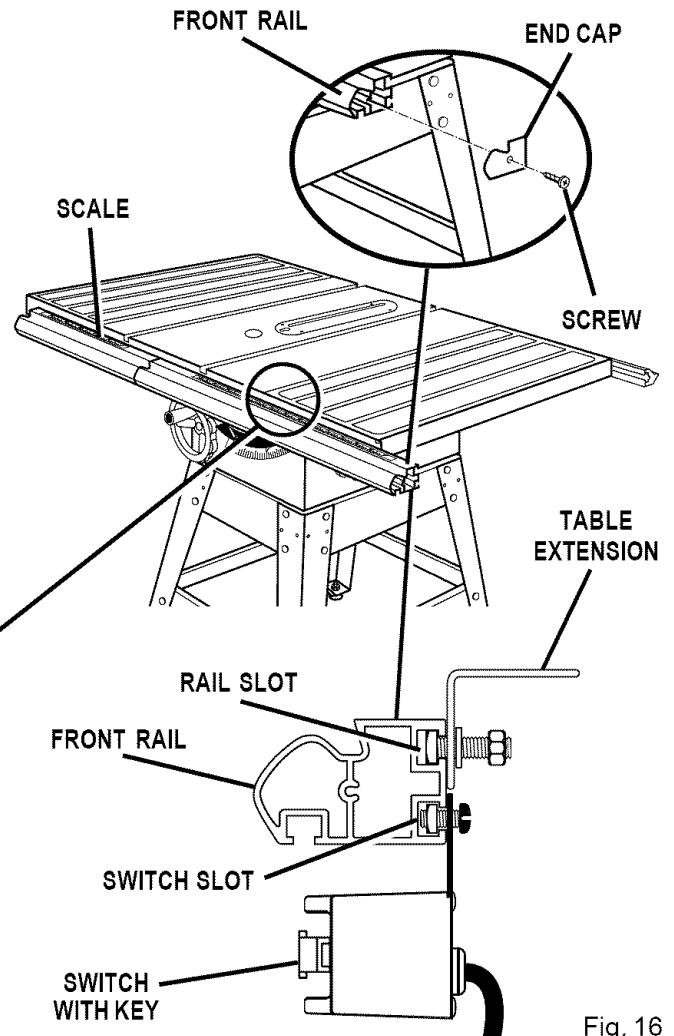
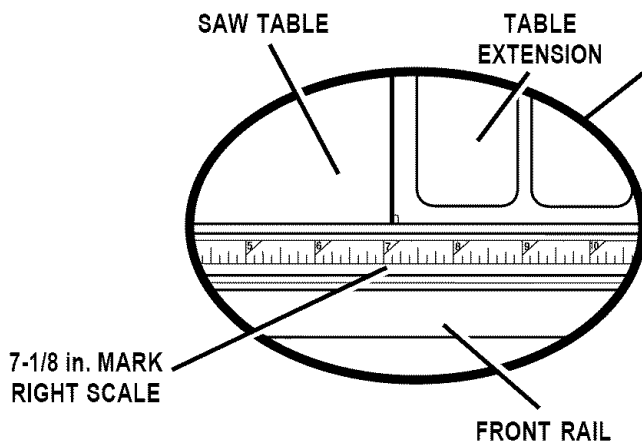

Fig. 16



ASSEMBLY

ALIGNING THE RIP FENCE AND FRONT RAIL

See Figures 17 and 18.

The rip fence scale indicator is installed on the right side of the rip fence but can be removed and re-installed on the left side if needed. If a cutting operation requires placing the rip fence on the left side of the blade, and you find relocating the scale indicator necessary, simply unscrew and re-attach it.

- Hook the back of the rip fence over the rear rail. Lower the front of the rip fence into the groove on the front rail.
- Slide the rip fence back and forth. It should move freely with about 1/16 in. clearance between the rip fence and table surface. If it doesn't, loosen the nuts holding the front and rear rails and adjust it up or down.
- When the fence rides smoothly, tighten all rail hex nuts with a 12 mm wrench.
- Remove the rip fence and repeat the steps in the two previous sections to install the remaining sections of the front and rear rail assemblies.
- Use the rail connectors provided to join each rail assembly together.
- Slide the rip fence back and forth to make sure it moves freely. Also check the clearance between the rip fence and the table surface on the other side of the blade.

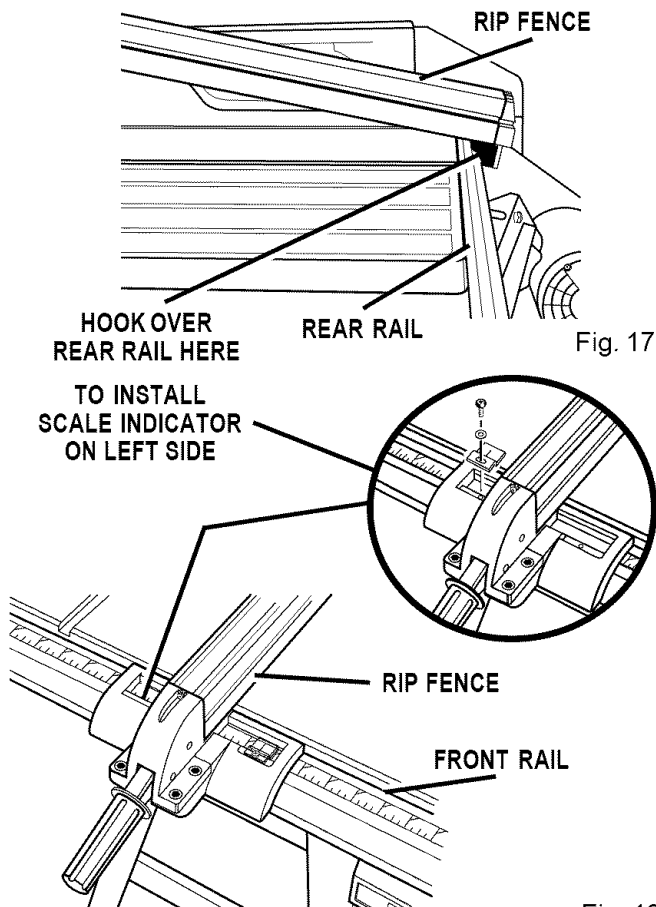

Fig. 18

MOUNTING THE MOTOR

See Figure 19.

- Get the motor assembly, the motor mounting plate and the following hardware:

- 4 hex bolts (5/16-18 x 1 in.)
- 8 flat washers (5/16 in.)
- 4 lock washers (5/16 in.)
- 4 hex nuts (5/16-18)
- 2 hex bolts (5/16-18 x 3/4 in.)

Note: Remaining hardware from this bag is used for installing the belt guard.

- Release the bevel lock handle (front of cabinet) and turn the bevel handwheel (side of cabinet) until the blade is fully vertical. Retighten the bevel lock handle.
- Align the holes in the motor mounting plate and the motor bracket so the top edges are even. Place a flat washer on the 1 in. bolts and insert into the holes.
- Install a flat washer, lock washer, and a hex nut on each bolt. Hand tighten only. This is the motor support assembly.
- Center the motor side to side on the motor mounting plate. Tighten the nuts with a 12 mm wrench.
- Insert the two rods on the motor support assembly into holes in the cradle. Push the motor in as far as it will go. Thread the two hex bolts into the cradle to clamp down on the rods. **Do not securely tighten bolts yet.**

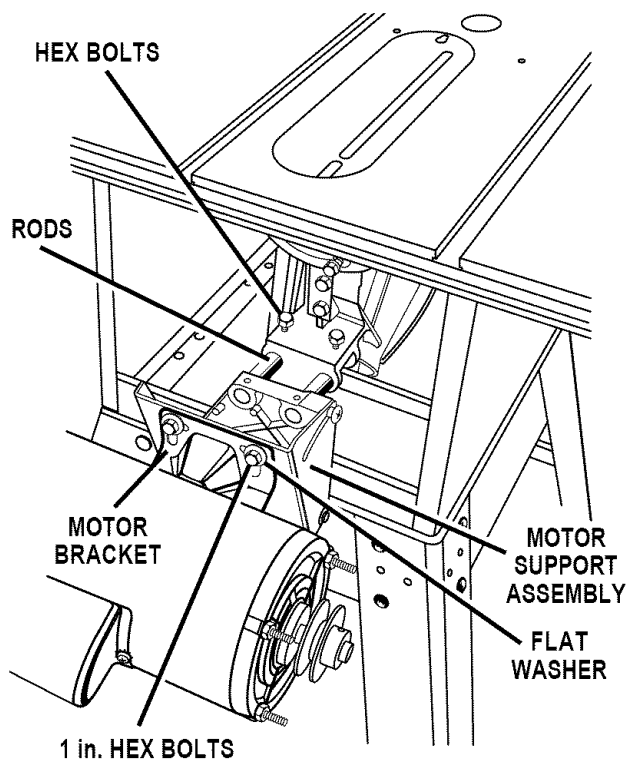

Fig. 19

ASSEMBLY

INSTALLING THE BELT AND BELT GUARD

See Figures 20 and 21.

- Get the belt, belt guard, 4 flat washers (#10) and 4 small hex nuts (#10-24).
- Lower the blade by turning the height handwheel.
- Slip the belt on the saw pulley (inside cabinet). Lift the motor forward and place the belt on the motor pulley.
- Check that the belt is straight and both pulleys are aligned. If not, adjust the motor on the motor support assembly. Refer to *Mounting the Motor*.
- Raise the saw blade all the way up.
- Pull the motor out until the belt is taut. Securely tighten the hex bolts above the rods with a 12 mm wrench.
- Put your hand around the belt halfway between the two pulleys and squeeze the belt until both sides of the belt touch. The motor should move freely as you squeeze the belt. If it does not, loosen the hex bolts and readjust the belt tension.
- Lower the blade with the height handwheel. Lift the motor forward and remove the belt.
- Open the hinged belt guard and place it over the motor screws on the motor pulley. Secure with flat washers and hex nuts. Securely tighten the hex nuts with a 8 mm wrench.
- Replace the belt and snap the guard closed.
- Check the clearances by indexing the blade. Turn the bevel handwheel to 45° and back. Use the height handwheel to fully lower and raise the blade.

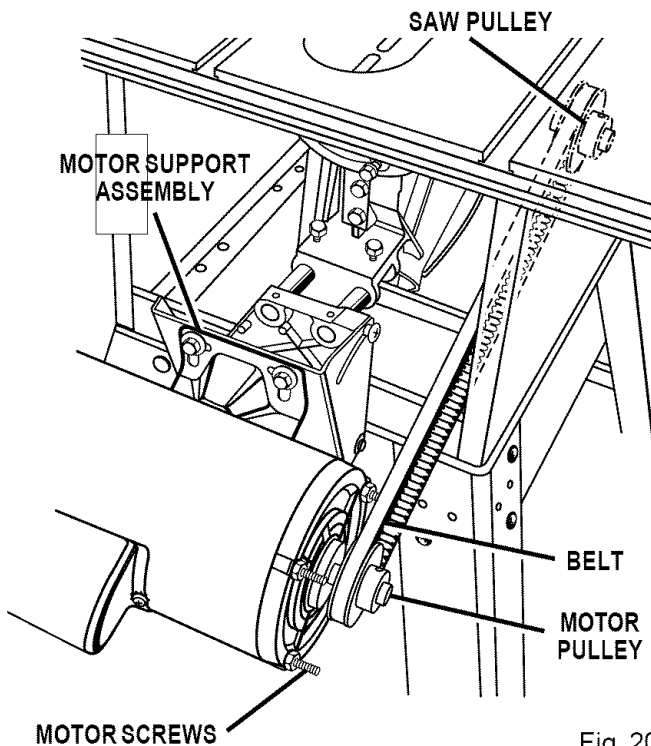

Fig. 20

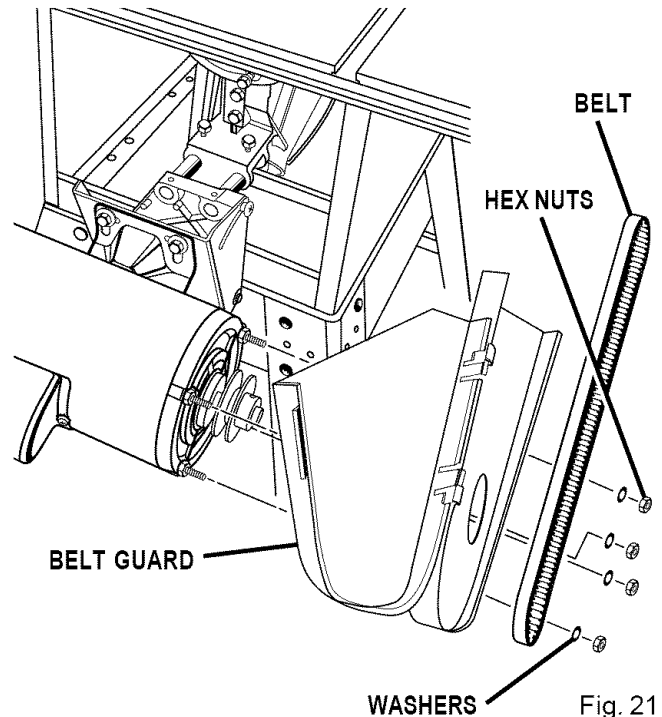

Fig. 21

CHECKING THE THROAT PLATE

See Figure 22.

- ⚠ **CAUTION:** The throat plate must be even with the table surface. If it is too high or too low, the workpiece can catch on uneven edges and cause kickback.
- Make sure the throat plate is flush with the table top. To change height of the throat plate, loosen the flat head screw that secures the throat plate and adjust the four setscrews with a 2 mm hex key. Do not allow the throat plate to bow up above the table surface.

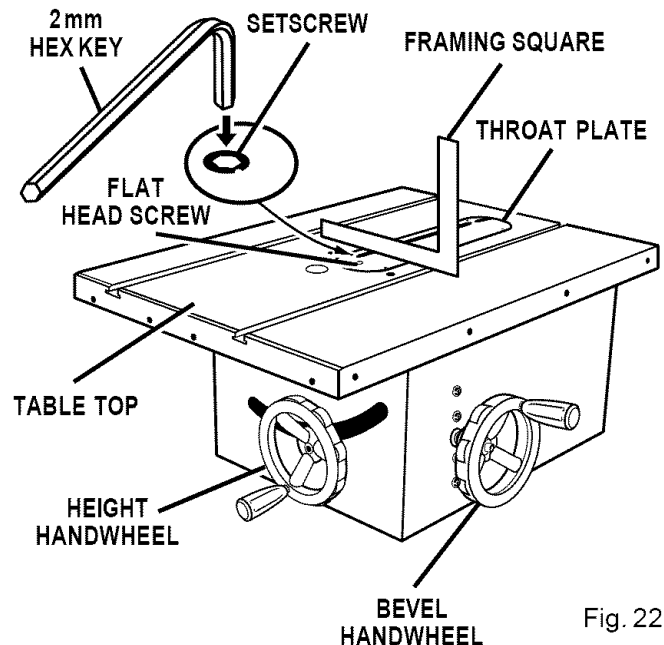

Fig. 22

ASSEMBLY

INSTALLING THE BLADE GUARD

See Figures 23 – 25.

⚠ WARNING: If the blade is not fully lowered, turn the height handwheel to lower the blade to prevent injury.

- Get the blade guard, the blade guard bracket, and the following hardware:
 - 2 hex bolts (5/16-18 x 1/2 in.)
 - 2 lock washers (5/16 in.)
 - 3 socket head screws (1/4-20 x 3/8 in.)
 - 3 flat washers (1/4 in.)
- Align the lower end of the blade guard bracket and the threaded holes of the cradle and insert the hex bolts and lock washers. Securely tighten with a 12 mm wrench.
- Remove the throat plate. See page 34.
- Put the blade guard assembly in place on the table top, aligning the screw holes in the riving knife to the holes in the bracket. Align the hole in the front of the riving knife base with the screw hole in the cradle.

Note: The screw hole is located under the slot in back of the throat plate.

- Insert two socket head screws and two flat washers in the two holes at the back of the riving knife base. Securely tighten with a 5 mm hex key.
- Insert the third socket head screw and flat washer into screw hole in cradle under throat plate. Securely tighten with a 5 mm hex key.
- Raise the blade all the way up.

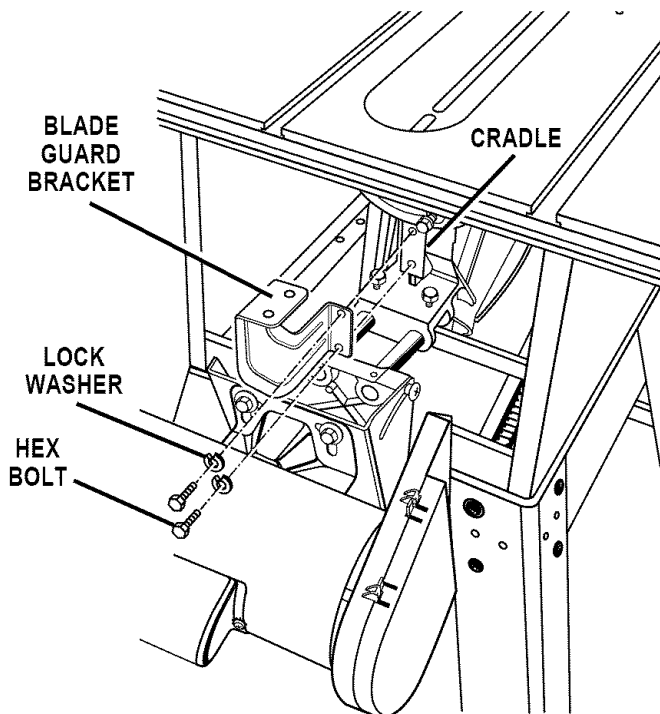

Fig. 23

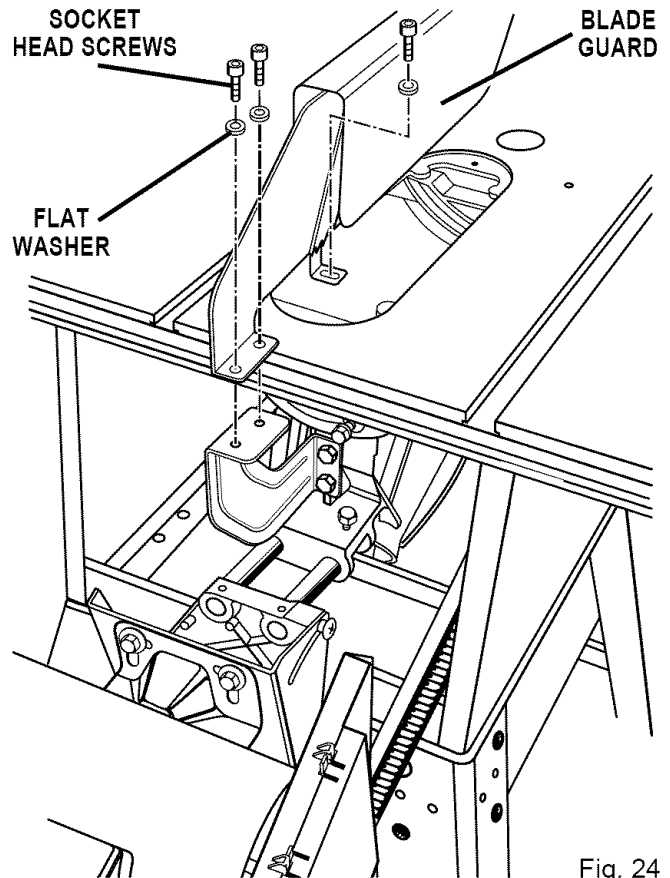

Fig. 24

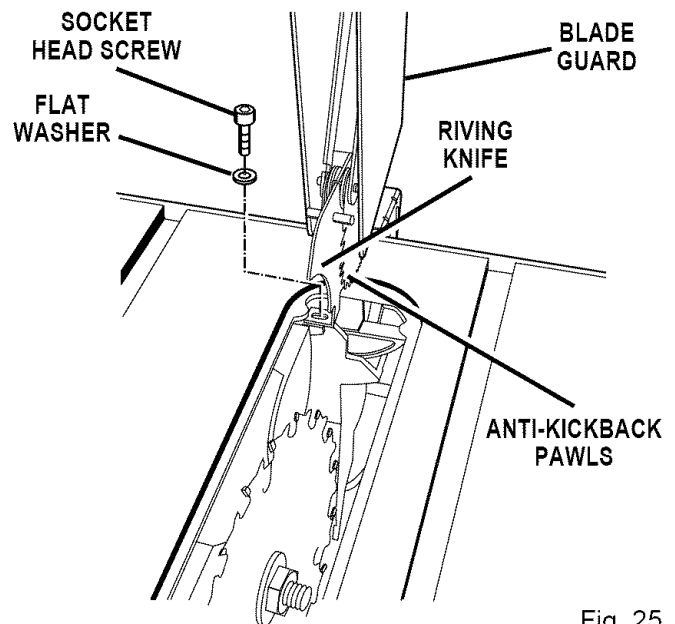

Fig. 25

ASSEMBLY

ALIGNING THE RIVING KNIFE WITH THE BLADE

See Figures 26 – 28.

⚠ WARNING: Make sure the switch is off, the switch key is removed, and your saw is unplugged. Failure to do so could result in accidental starting, causing serious personal injury.

The riving knife must be aligned with and centered over the blade.

⚠ WARNING: It is important to install and adjust the riving knife correctly. Poor alignment could cause kickback and throw the workpiece at the operator.

- Raise the blade guard.
- Place a framing square or straightedge beside the blade on the left. See Figure 26.
- Loosen the front screw on the riving knife with a 5 mm hex key. See Figure 27.
- Center the riving knife over the blade. See Figure 28.
- Securely tighten the screw with a 5 mm hex key.

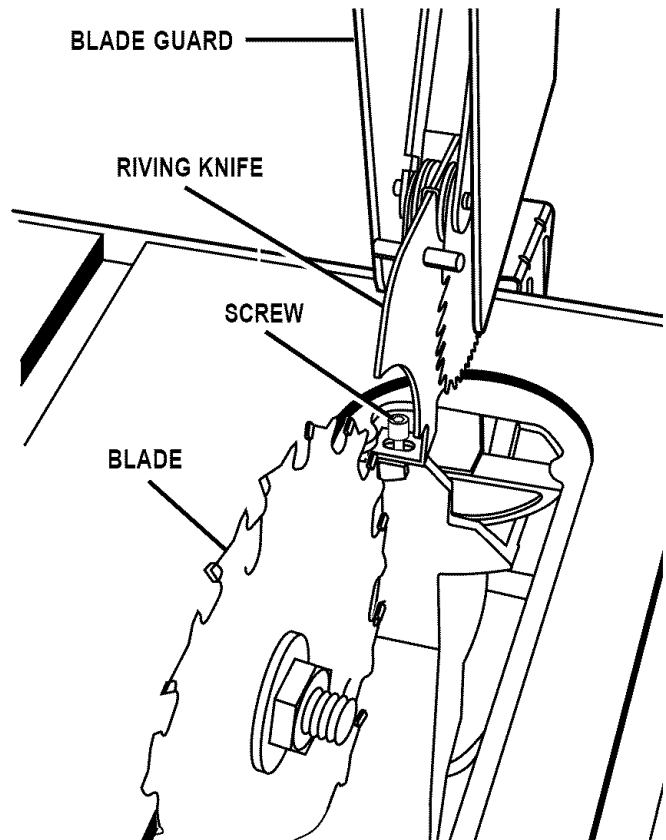

Fig. 27

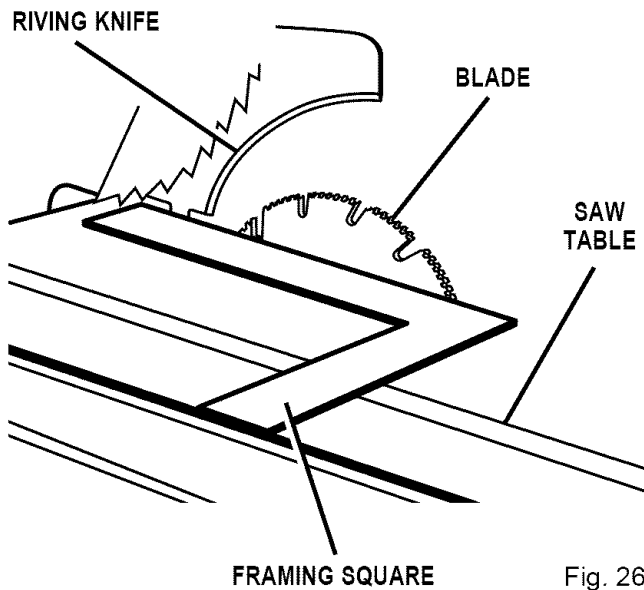
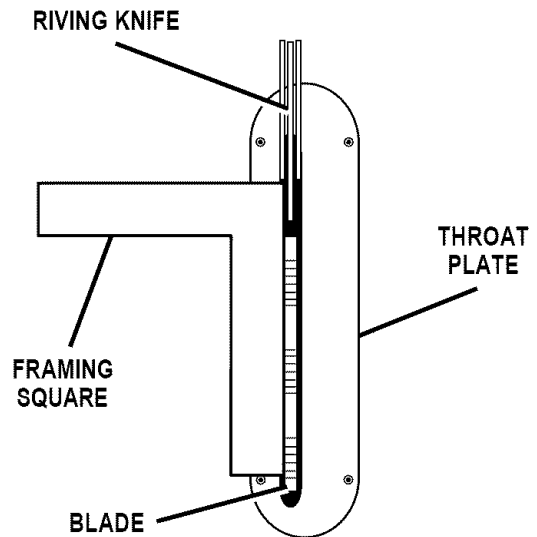

Fig. 26



TOP VIEW OF SAW WITH RIVING KNIFE SHOWN CENTERED OVER BLADE

Fig. 28

ASSEMBLY

CHECK HEELING (PARALLELING) OF THE SAWBLADE TO THE MITER GAGE GROOVE

See Figures 29 – 30.

DO NOT loosen any screws until you have checked with a square and made sure adjustments are necessary. Once the screws are loosened, these items must be reset.

⚠ WARNING: Make sure the switch is off, the switch key is removed, and your saw is unplugged. Failure to do so could result in accidental starting, resulting in serious personal injury.

⚠ WARNING: The sawblade must be parallel to the miter gage groove so the wood does not bind, resulting in kickback. You could be hit or cut.

- Lift the blade guard. Raise the blade all the way by turning the height handwheel.
- Mark beside one of the sawblade teeth at the front of the blade. Place a framing square beside the blade on the mark. Be sure the framing square is between the teeth and flat against the blade. Measure the distance to the right miter gage groove.
- Turn sawblade so the marked tooth is at the back.
- Move the square to the rear and again measure the distance to the right miter gage groove. **If the distances are the same, the blade and the miter gage groove are parallel. No adjustments are needed.**
- If the distances measured are different, adjust the table bracket underneath the saw. See “Heeling (Paralleling) The Sawblade To The Miter Gage Groove” in the Adjustments section.

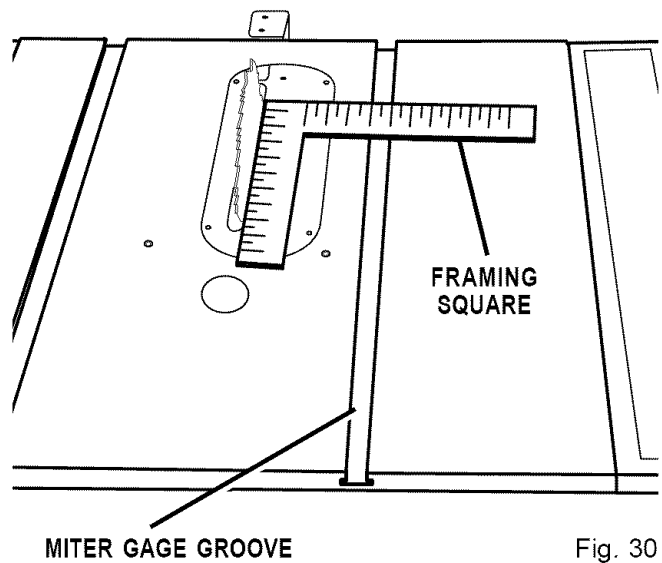
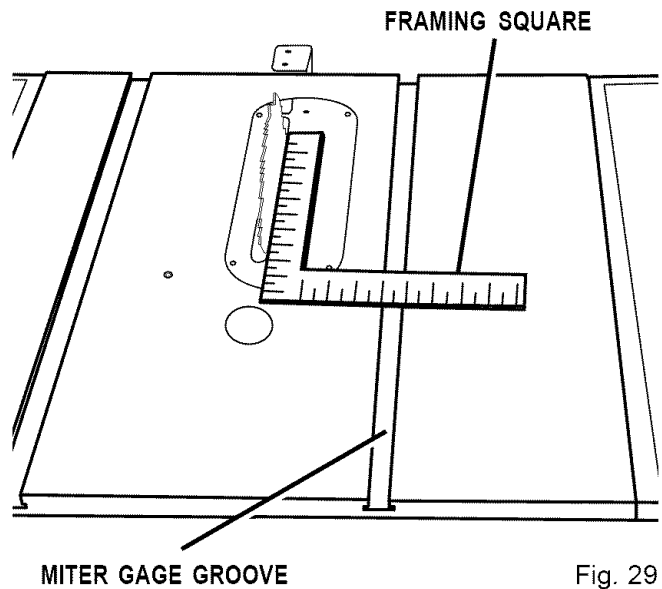

ASSEMBLY

CHECKING RIP FENCE AND BLADE ALIGNMENT

See Figures 31 – 33.

The rip fence is self-aligning but should be checked before first use.

⚠ WARNING: Failure to align the rip fence to the blade can cause jams and kickback, resulting in serious personal injury.

- Slide the rip fence to the miter gage groove, which is parallel to blade. Do not lock the rip fence.
- Place a framing square against the rip fence, with the long end towards the front of the blade. Measure the distance from the rip fence to the edge of the blade.
- Move the square to the back of the blade and measure the distance from the other end of the rip fence to the blade.
- If the distances are different, loosen the four screws around the rip fence handle with a 6 mm hex key. Alternate the order (loosen the screw opposite, not next to the first one).
- Hold the fence handle against the front rail and align the rip fence with the blade.
- Retighten the screws in alternating order and check the alignment.
- Repeat until the rip fence is aligned.
- Lock the rip fence handle in desired position by rotating the handle down.

To complete assembly of the saw, plug the motor cord into the back of the switch. Run the cord around the side of the cabinet. Secure it to the side of the cabinet with the cord clip and screw provided. Use care with the cord around sharp edges. Your saw is now set up to provide years of high quality performance.

Note: To insure proper self alignment when positioning rip fence, push sides of scale indicator housing against front rail before locking rip fence handle.

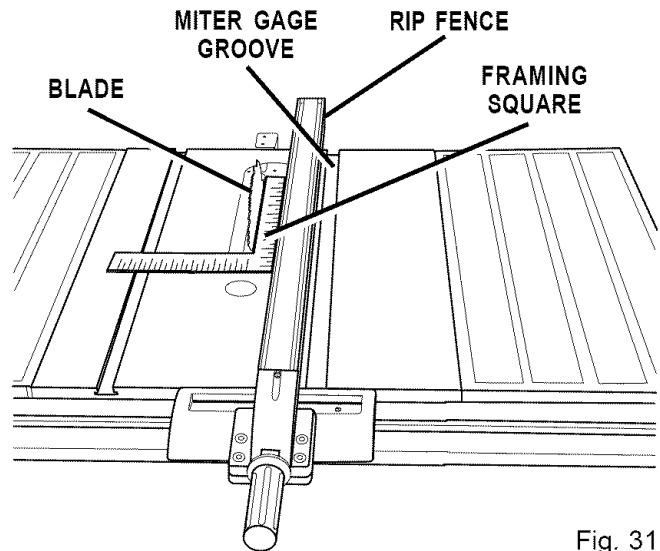

Fig. 31

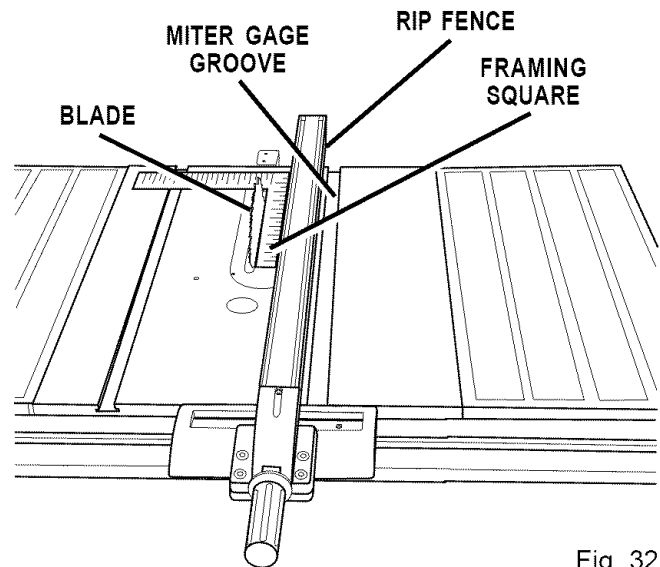

Fig. 32

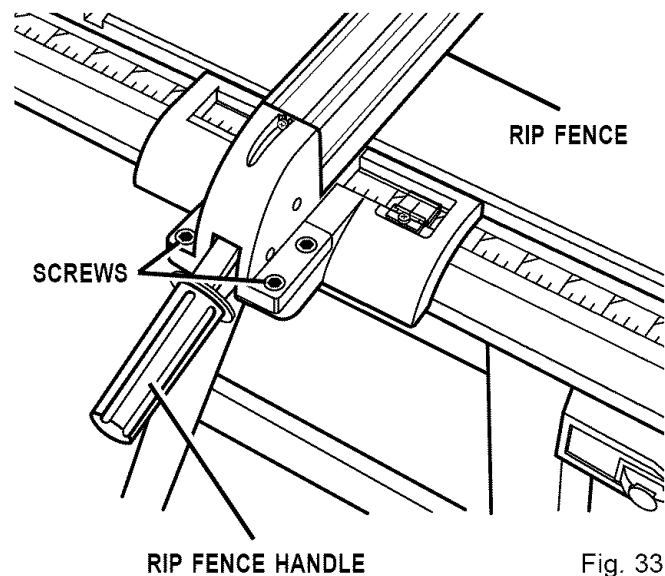

Fig. 33

ASSEMBLY

CHECKING SQUARENESS OF EXTENSION TABLES TO SAW TABLE

See Figure 34.

The extension tables should be checked for squareness to the saw table for smooth operation of the rip fence and rails.

Place a square on the saw table, with the short end up and check. The long end of the square should extend across one of the extension tables. If the extension table is not square with the saw table, proceed as follows:

- Loosen the two hex nuts (one for each rail) securing the front and rear rails to the extension table. **Do not** loosen hex nuts securing rails to saw table.
- Raise or lower extension table until it is square with the saw table.
- Tighten hex nuts securely.
- Check extension table on opposite side of blade. Repeat the above procedure if necessary.

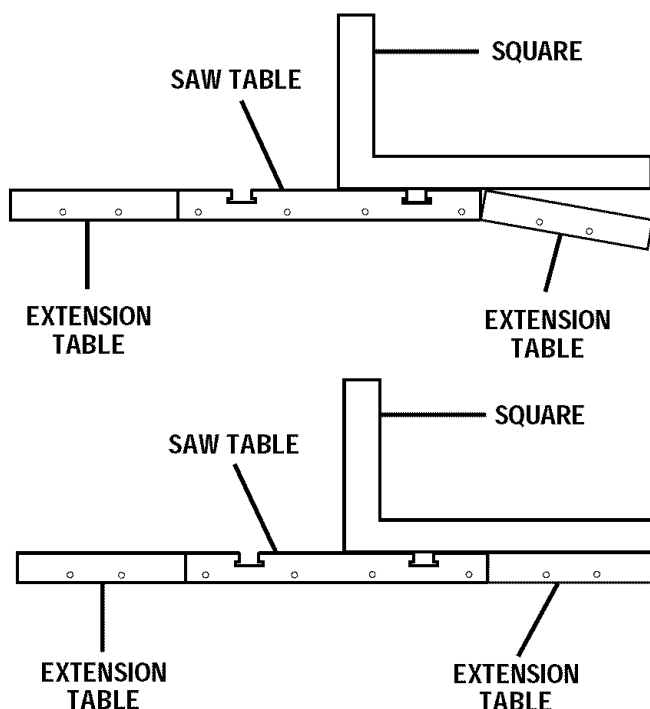

Fig. 34

ADJUSTMENTS

To avoid unnecessary setups and adjustments, a good practice is to check your setups carefully with a framing square and make practice cuts in scrap wood before making finish cuts in good workpieces. Do not start any adjustments until you have checked with a square and made test cuts to be sure adjustments are needed.

REPLACING THE BLADE

See Figures 35 – 37.

⚠ WARNING: Make sure the switch is off, the switch key is removed, and your saw is unplugged. Failure to do so could result in accidental starting, resulting in serious personal injury.

- Raise the blade guard and remove the throat plate. To remove, loosen the screw at the front with a phillips screwdriver and lift the front end. Pull it out toward the front end.
- Raise the blade to its highest position by turning the height handwheel clockwise. Angle the blade straight up by loosening the bevel lock handle and turning the bevel handwheel. Wedge a piece of scrap wood against the front of the blade. See Figure 35.
- Loosen the blade nut with the blade wrench provided with your saw. Remove the blade nut and blade washer. Carefully remove the scrap wood and blade.
- To replace the blade with an accessory blade, follow the instructions provided with the accessory.
- To install a standard blade, place the new blade on the arbor shaft, with teeth pointing down toward the front of the saw. Wedge a piece of scrap wood at the back of the blade. See Figure 37.

⚠ CAUTION: The teeth must point down toward the front of the saw to work properly. Otherwise, damage to the blade, saw, or workpiece can occur.

- Place the blade washer and the blade nut over the blade arbor. Be sure the dome side of the blade washer faces out from the blade and that all items are snug against the arbor housing. Tighten securely.
- Remove the scrap wood and rotate the blade by hand to make sure it turns freely.
- Slip the throat plate into the opening and push it toward the back of the saw to engage the spring clip. Securely tighten the screw. If the throat plate is not flush with the table, adjust the setscrews with a 2 mm hex key. Do not allow the throat plate to bow up above the table surface.

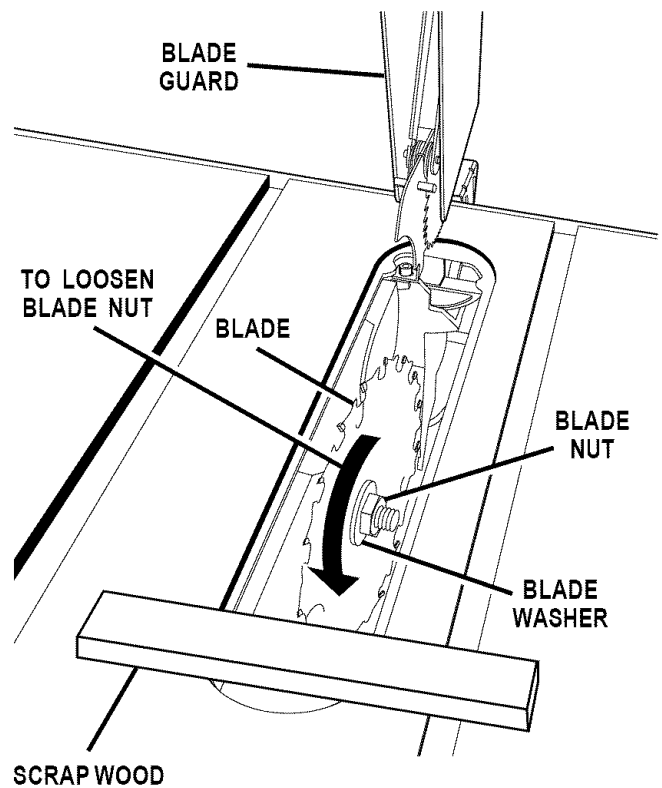

Fig. 35

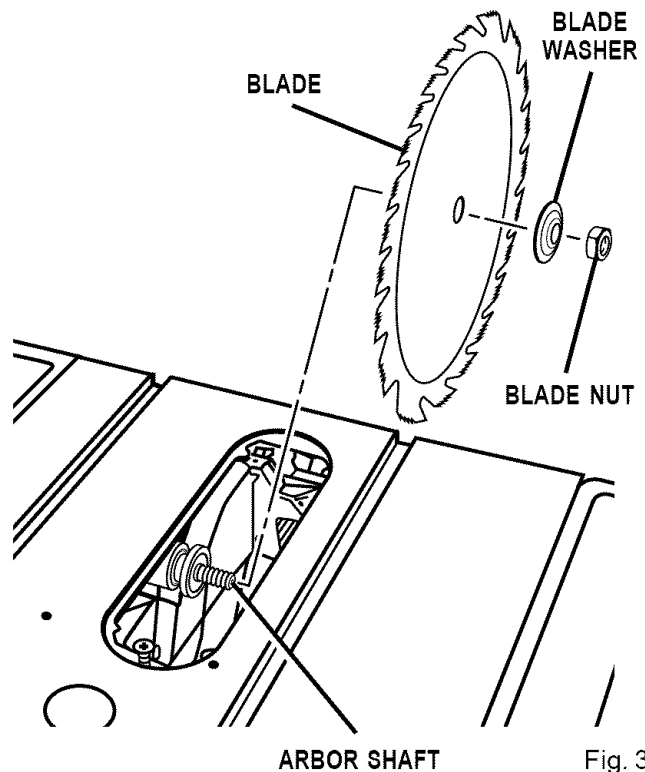

Fig. 36

ADJUSTMENTS

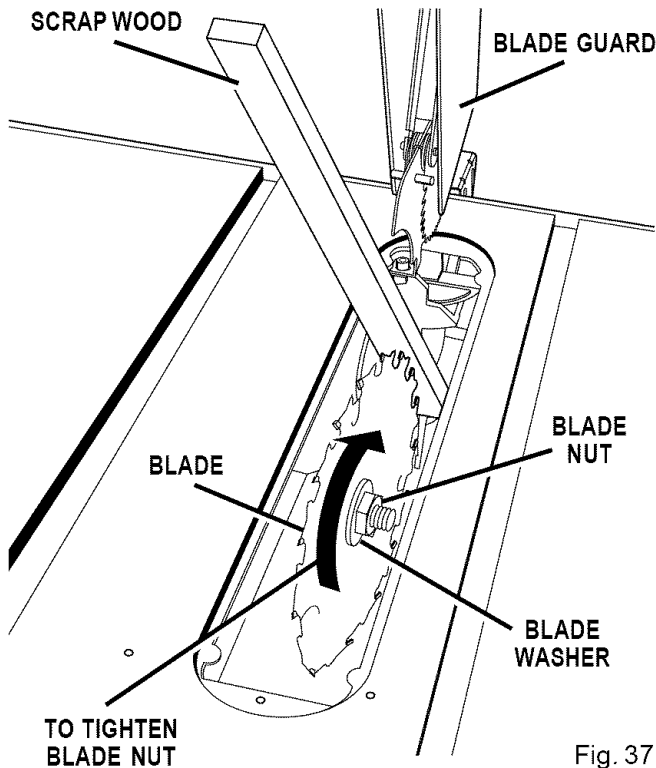

Fig. 37

HEELING (PARALLELING) THE SAWBLADE TO THE MITER GAGE GROOVE

See Figures 38 – 40.

DO NOT loosen any screws for this adjustment until you have checked with a square and made test cuts to be sure adjustments are necessary. Once the screws are loosened, these items must be reset.

WARNING: Make sure the switch is off, the switch key is removed, and your saw is unplugged. Failure to do so could result in accidental starting, resulting in serious personal injury.

WARNING: The sawblade must be parallel to the miter gage groove so the wood does not bind, resulting in kickback. You could be hit or cut.

- Lift the blade guard. Raise the blade all the way by turning the height handwheel.
- Mark beside one of the sawblade teeth at the front of the blade. Place a framing square beside the blade on the mark. Be sure the framing square is between the teeth and flat against the blade. Measure the distance to the right miter gage groove.
- Turn sawblade so the marked tooth is at the back.
- Move the square to the rear and again measure the distance to the right miter gage groove. **If the distances are the same, the blade and the miter gage groove are parallel. No adjustments are needed.**

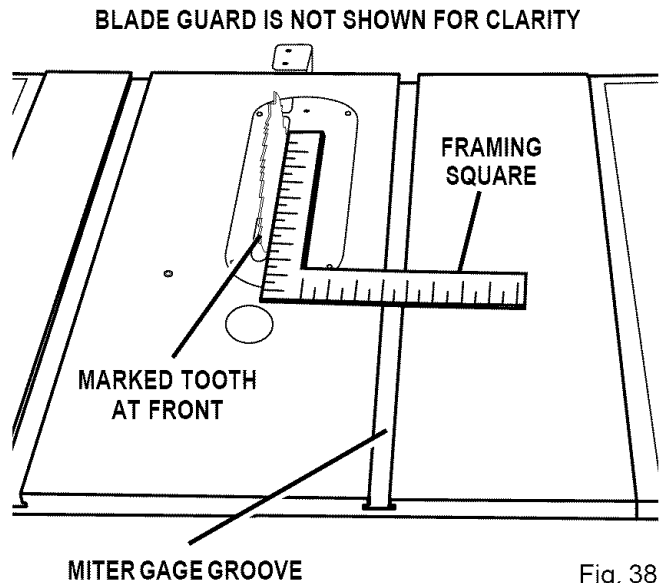

Fig. 38

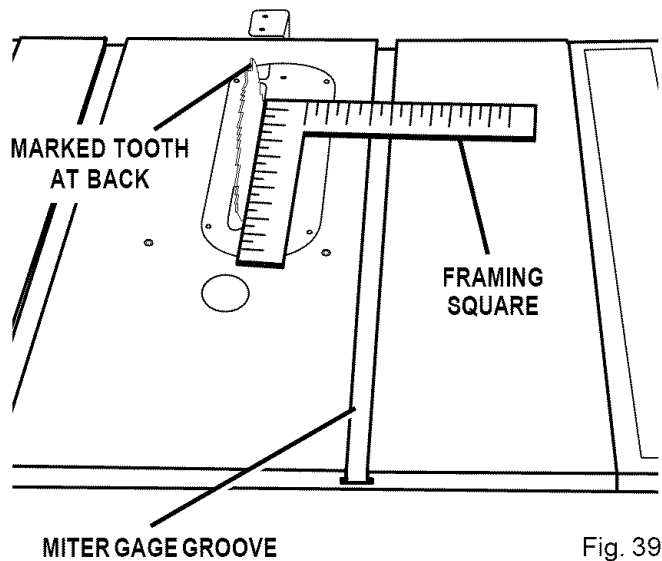

Fig. 39

- If the distances measured are different, adjust the table bracket underneath the saw.

WARNING: When reaching under the saw table, wear gloves. Accidental contact with the blade could cause a cut resulting in serious personal injury.

- Remove the throat plate by loosening the front screw with a phillips screwdriver. Lift the throat plate and pull it out by the front end.
- Lower the blade completely with the height handwheel. You can then access the table brackets through the throat plate opening.
- From the back, loosen the three rear screws holding rear table bracket using a 12 mm wrench.
- If the blade was too far from the miter gage groove, move the rear bracket toward the miter gage groove. Tap with a block of wood and hammer.

ADJUSTMENTS

- If the blade was too close to the miter gage groove, back the bracket away with the block of wood and hammer.
- Tighten the screws, raise the blade and recheck.
- Repeat until blade is parallel to miter gage groove.
- If the blade is not parallel, adjust the front table bracket. Tilt the blade to 45° with the blade lock handle and bevel handwheel.
- From the back of the saw, loosen the bolts holding the front table bracket, as well as the rear table bracket.
- Reposition the blade to 90° with the bevel handwheel and blade lock handle.
- Lower the blade and move the brackets as needed. Retighten all bracket screws.
- Raise the blade and recheck. Repeat until the blade is parallel to the miter gage groove.
- Place the throat plate in the opening and push it toward the rear of saw base to engage the spring clip.

Note: The keyslot in the throat plate will drop over the front screw.

- Tighten the screw. Do not allow the throat plate to bow up above the table surface.

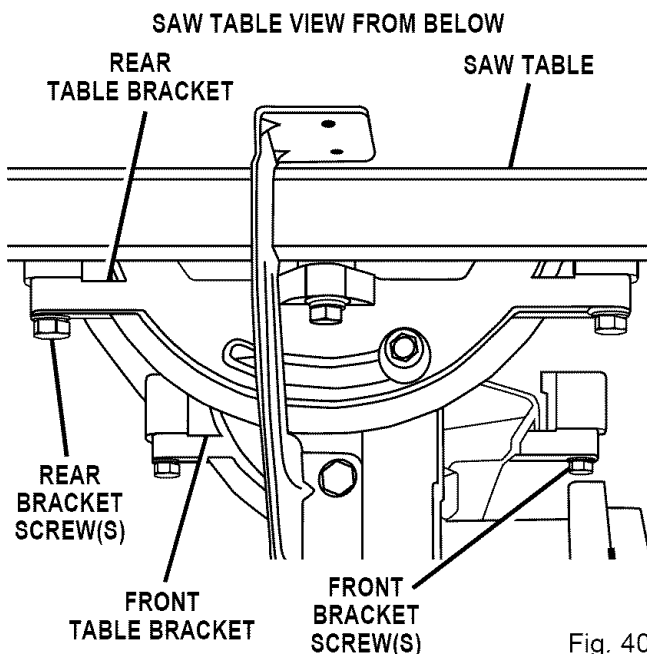

Fig. 40

SETTING THE BEVEL STOPS AND INDICATOR

See Figures 41 and 42.

WARNING: Make sure the switch is off, the switch key is removed, and your saw is unplugged. Failure to do so could result in accidental starting, resulting in serious personal injury.

The bevel scale should show 0° when the blade is set vertical at 90° to table, and 45° when blade is at 45° tilt.

- Raise the blade all the way up by turning the height handwheel. Lift the blade guard.
- Loosen bevel lock handle and turn the bevel handwheel clockwise to tilt the blade. Reverse it and turn the handwheel counterclockwise until it stops.
- Check the blade angle with a combination square. Don't let the square touch a blade tooth. The blade should be at 90° and the scale indicator at 0°.

Note: The scale indicator is the plastic plate on the scale at the front of the cabinet.

- If the scale indicator does not point to 0°, loosen the scale indicator with a screwdriver, adjust it within the slot, and retighten the screw.
- If the blade angle is wrong, adjust the 90° stop screw (left of the blade, looking from the front). Start by turning the 90° stop screw three or four turns with a 4 mm hex key.

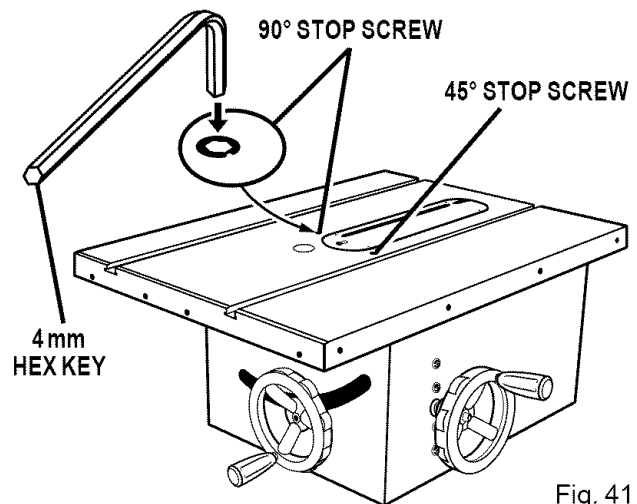

Fig. 41

- Turn the bevel handwheel clockwise once, then back counterclockwise to square blade with table.
- Tighten the 90° stop screw and recheck that the blade is square in a 90° position. If not, repeat. When the blade is square, check the scale indicator. If it is not at zero, reset the scale indicator as before.

ADJUSTMENTS

- Check the 45° setting. Tilt the blade with the bevel handwheel as far as it will go to the left. Place the square against the blade (be sure the square is not against one of the saw teeth). If the blade is not at 45°, unscrew the 45° stop screw (right of blade), turn the handwheel until the blade is correct, and tighten the screw. Recheck and repeat if necessary.
- Check that the scale indicator is at 45°.
- If not, loosen the scale indicator with a screwdriver, adjust it within the slot, and retighten the screw.

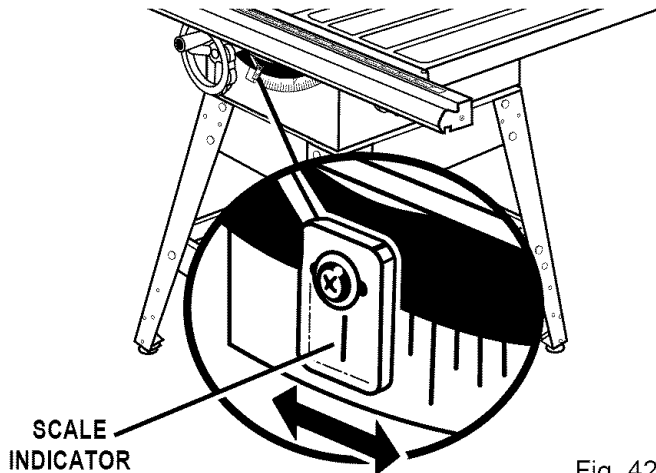

Fig. 42

ADJUSTING THE MITER GAGE

See Figure 43.

You can set the miter gage at 0° and plus or minus 45° with the miter gage stop pin and adjustable stop screws.

Note: The miter gage provides close accuracy in angled cuts. For very close tolerances, test cuts are recommended.

- Loosen knob and pull out on stop pin to rotate miter gage base past stop screws.
- Loosen the lock nut of the 0° stop screw at the stop pin with a 8 mm wrench.
- Place a 90° square against the miter gage rod and the miter gage base.
- If the rod is not square, loosen the knob, adjust the rod, and tighten the knob.
- Adjust the 0° stop screw until it rests against the stop pin.
- Adjust the plus and minus 45° stop screws using a 45° triangle and the steps above.

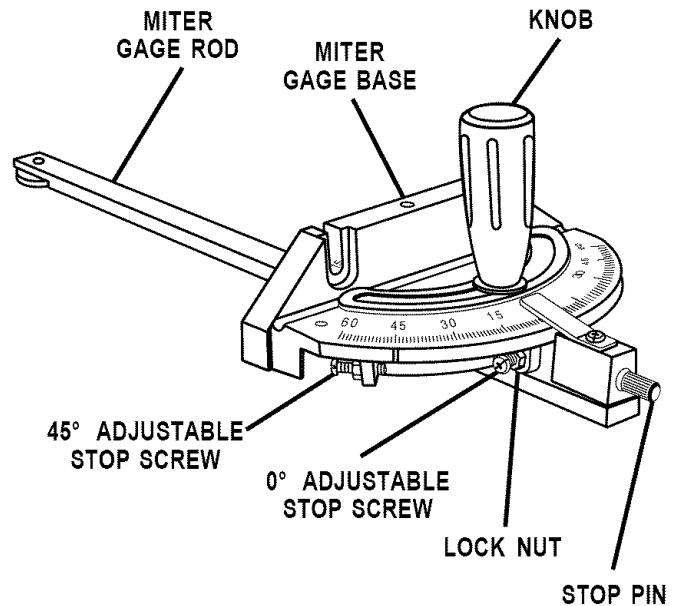

Fig. 43

ADJUSTMENTS

REMOVING / REPLACING THE THROAT PLATE

See Figure 44.

⚠ WARNING: Make sure the switch is off, the switch key is removed, and your saw is unplugged. Failure to do so could result in accidental starting, resulting in serious personal injury.

- To remove the throat plate, first loosen the screw in the throat plate with a phillips screwdriver and lift the front end. Pull it out toward the front of the saw.
- To re-install the throat plate, place it in the opening. Push it toward the rear of saw base to engage the spring clip.

Note: The keyslot in the throat plate will drop over the screw.

- Check that the throat plate is even with the table top. If not, adjust the four set screws with a 2 mm hex key. See the procedure in the *Assembly* section.
- Securely tighten throat plate screw. Do not allow the throat plate to bow up above the table surface.

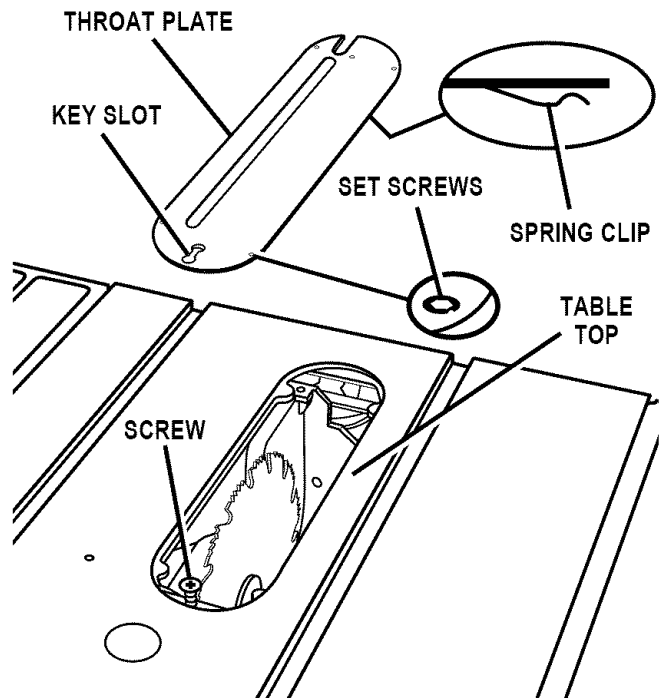

Fig. 44

OPERATION

BASIC OPERATION OF THE TABLE SAW

A table saw can be used for straight-line cutting operations such as cross cutting, ripping, mitering, beveling, and compound cutting. It can make dado or molding cuts with optional accessories.

The 3-prong plug must be plugged into a matching outlet that is properly installed and grounded according to all local codes and ordinances. Improper connection of the equipment can result in electric shock. Check with an electrician or service personnel if you are unsure about proper grounding. Do not modify the plug; if it will not fit the outlet, have the correct outlet installed by a qualified electrician. Refer to the *Electrical* page of this manual.

Note: This table saw is designed to cut wood and wood composition products only.

CAUSES OF KICKBACK

Kickback can occur when the blade stalls or binds, kicking the workpiece back toward you with great force and speed. If your hands are near the sawblade, they may be jerked loose from the workpiece and may contact the blade. Obviously, kickback can cause serious injury, and it is well worth using precautions to avoid the risks.

Kickback can be caused by any action that pinches the blade in the wood, such as the following:

- Making a cut with incorrect blade depth
- Sawing into knots or nails in the workpiece
- Twisting the wood while making a cut
- Failing to support work
- Forcing a cut
- Cutting warped or wet lumber
- Using the wrong blade for the type of cut
- Not following correct operating procedures
- Misusing the saw
- Failing to use the anti-kickback pawls
- Cutting with a dull, gummed-up, or improperly set blade

AVOIDING KICKBACK

- Always use the correct blade depth setting. The top of the blade teeth should clear the workpiece by 1/8 in. to 1/4 in.
- Inspect the work for knots or nails before beginning a cut. Knock out any loose knots with a hammer. Never saw into a loose knot or nail.
- Always use the rip fence when rip cutting and the miter gage when cross cutting. This helps prevent twisting the wood in the cut.
- Always use clean, sharp, and properly-set blades. Never make cuts with dull blades.

- To avoid pinching the blade, support the work properly before beginning a cut.
- When making a cut, use steady, even pressure. Never force cuts.
- Do not cut wet or warped lumber.
- Always hold your workpiece firmly with both hands or with pushsticks. Keep your body in a balanced position to be ready to resist kickback should it occur. Never stand directly in line with the blade.
- Use the right type of blade for the cut being made.

CUTTING AIDS

See *Figure 45*.

Pushsticks are devices used for safely pushing a workpiece through the blade instead of using your hands. They can be made in various sizes and shapes from scrap wood to use in a specific project. The stick must be narrower than the workpiece, with a 90° notch in one end and shaping for a grip on the other end.

A pushblock has a handle fastened by recessed screws from the underside. Use it on non-through cuts.

CAUTION: Be sure the screw is recessed to avoid damaging the saw or workpiece.

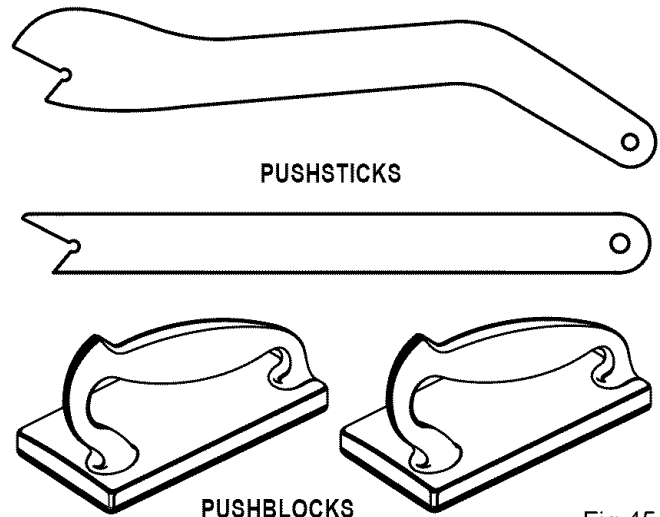

Fig.45

A featherboard is a device used to help control the workpiece by guiding it securely against the table or fence. Featherboards are especially useful when ripping small workpieces and for completing non-through cuts. The end is angled, with a number of short kerfs to give a friction hold on the workpiece. Lock it in place on the table with a C-clamp. Test that it could resist kickback.

WARNING: Place the featherboard against the uncut portion of the workpiece, to avoid kickback that could cause serious personal injury.

OPERATION

TYPES OF CUTS

See Figure 46.

There are six basic cuts: 1) the cross cut, 2) the rip cut, 3) the miter cut, 4) the bevel cross cut, 5) the bevel rip cut, and 6) the compound (bevel) miter cut. All other cuts are combinations of these basic six. Operating procedures for making each kind of cut are given later in this section.

⚠ WARNING: Always make sure the blade guard and anti-kickback pawls are in place and working properly when making these cuts to avoid possible injury.

Cross cuts are straight 90° cuts made across the grain of the workpiece. The wood is fed into the cut at a 90° angle to the blade, and the blade is vertical.

Rip cuts are made with the grain of the wood. To avoid kickback while making a rip cut, make sure one side of the wood rides firmly against the rip fence.

Miter cuts are made with the wood at any angle to the blade other than 90°. The blade is vertical. Miter cuts tend to “creep” away from the miter fence during cutting. This can be controlled by holding the workpiece securely against the miter fence.

⚠ WARNING: Always use a pushstick with small pieces of wood, and also to finish the cut when ripping a long narrow piece of wood, to prevent your hands from getting close to the blade.

Bevel cuts are made with an angled blade. Bevel cross cuts are across the wood grain, and bevel rip cuts are with the grain. The rip fence must always be on the right side of the blade for bevel rip cuts.

Compound (or bevel) miter cuts are made with an angled blade on wood that is angled to the blade. Be thoroughly familiar with making cross cuts, rip cuts, bevel cuts, and miter cuts before trying a compound miter cut.

⚠ WARNING: All blades and cutting accessories must be rated for at least 5,000 rpm to prevent possible injury.

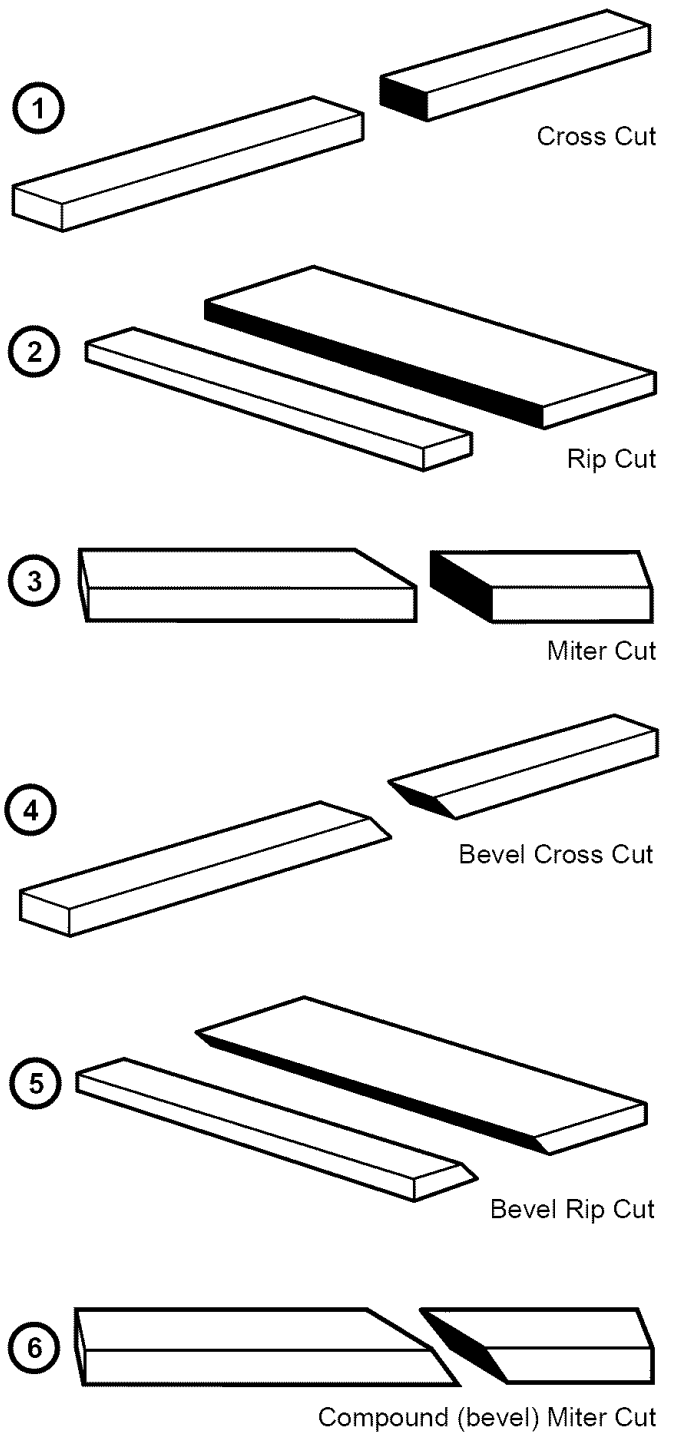

Fig. 46

OPERATION

MAKING A CROSS CUT

See Figures 47 and 48.

It is recommended that you make test cuts on scrap wood. Stand at the front of the saw and push the wood to the blade with the miter gage.

- ⚠ **WARNING:** Make sure the blade guard is lowered over blade and is working properly to prevent possible injury.
- Set the blade to the right depth for the workpiece by turning the height handwheel.
- Set the miter gage to 0°. Make sure miter gage knob is securely tightened.
- Place a support the same height as the top of the saw table behind the saw for the cut work.
- The miter gage may be used in either of the two grooves in the table. When using left groove, hold workpiece firmly against the miter gage base with your left hand and grip the knob with your right hand. When using the right groove, hold workpiece firmly against the miter gage base with your right hand and grip the knob with your left hand. See Figure 47.
- Check that the wood is not touching the blade. Insert the key and lift the switch to the **ON** position.
- Let the blade build up to full speed before feeding the workpiece into the blade with the miter gage.

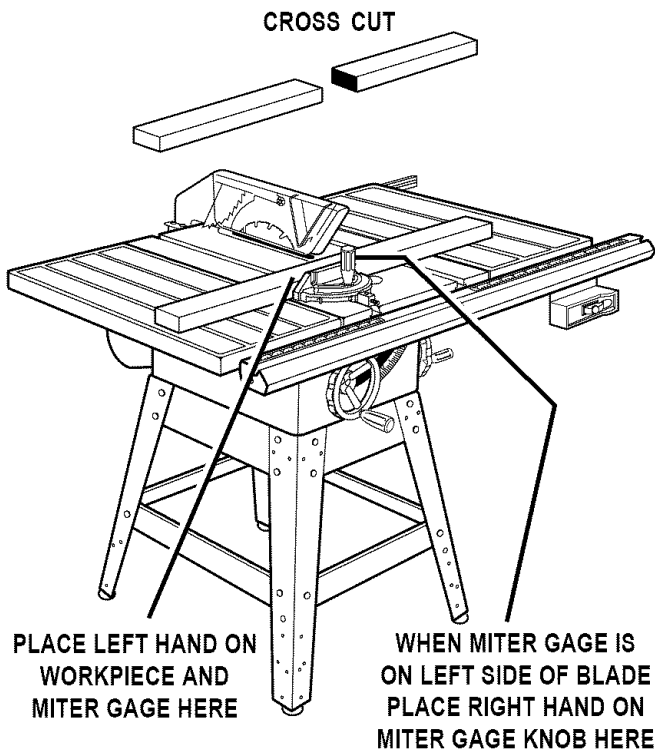

Fig. 47

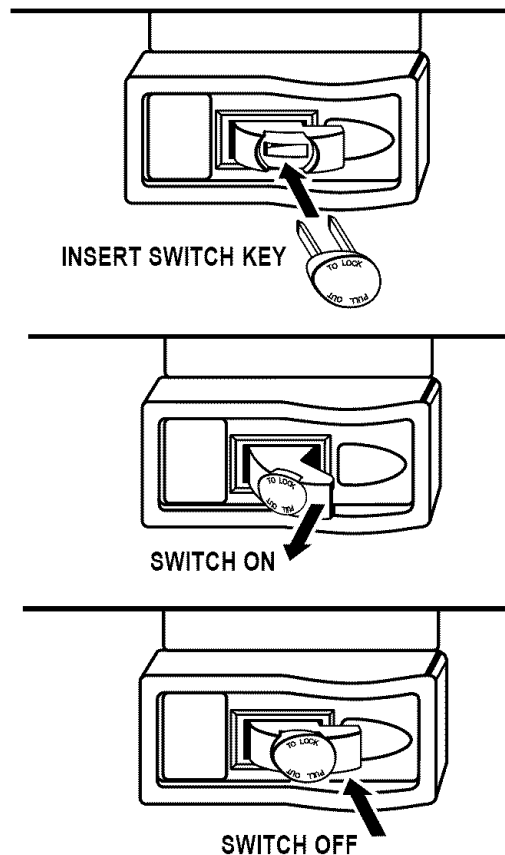

Fig. 48

- Hold the work firmly against the miter gage and push the miter gage to feed the work into the blade.
- When the work is completed, press the switch off and remove the key.

MAKING A RIP CUT

See Figure 49.

Making a test cut on scrap wood is highly recommended. From the front of the saw, position the wood against the rip fence and push it to the blade with a pushstick. Be sure the end of the wood is square.

- ⚠ **WARNING:** Never stand directly in the line of cut. Stand to the side to reduce risk of injury.
- ⚠ **WARNING:** Never push a small piece of wood into the blade with your hand.
- ⚠ **WARNING:** Make sure the blade guard is lowered over blade and is working properly to prevent possible injury.
- Remove the miter gage and attach the rip fence over the rails.

OPERATION

- Place a support the same height as the top of the saw table behind the saw for the cut work.
- Position the rip fence the correct distance from the blade for the cut.
- For small pieces of wood, use a pushstick to move the wood into and past the blade.
- Make sure the wood is not touching the blade. Insert the key and lift the switch to the **ON** position. Let the blade build up to full speed before feeding the workpiece into the blade.
- When the work is completed, press the switch off and remove the key.

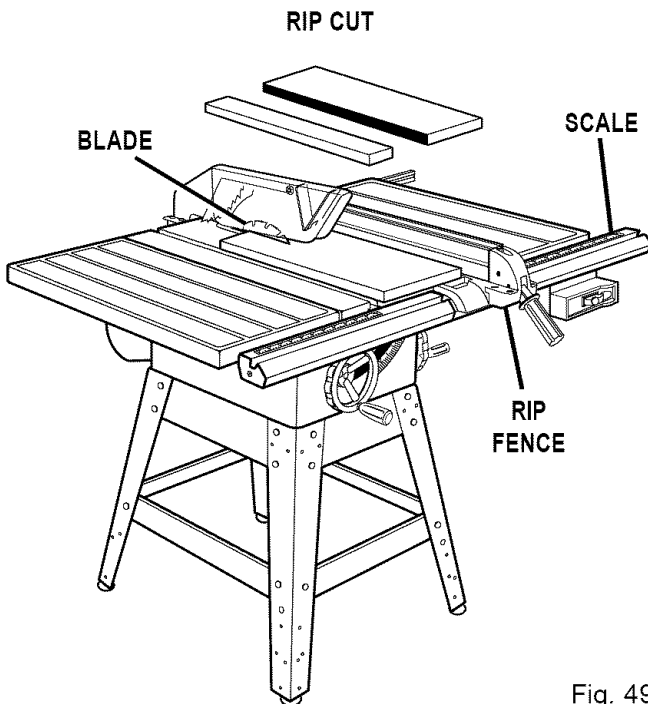

Fig. 49

MAKING A MITER CUT

See Figure 50.

Make a test cut on scrap wood. From the front of the saw, push the wood to the blade with the miter gage.

⚠ WARNING: Make sure the blade guard is lowered over blade and is working properly to prevent possible injury.

- Check that the blade is at the correct height for the workpiece. To change the height, turn the height hand wheel.
- To set the wood angle, loosen the miter gage knob, set the angle with the indicator on the miter gage, then retighten miter gage knob.

- Place a support the same height as the top of the saw table behind the saw for the cut work.
- Make sure the wood is not touching the blade before turning on the saw. Insert the key and lift the switch to the **ON** position. Let the blade build up to full speed before moving the miter gage to feed the workpiece into the blade.
- Hold the work firmly against the miter gage and push the miter gage to feed the work into the blade.
- When the work is completed, press the switch off and remove the key.

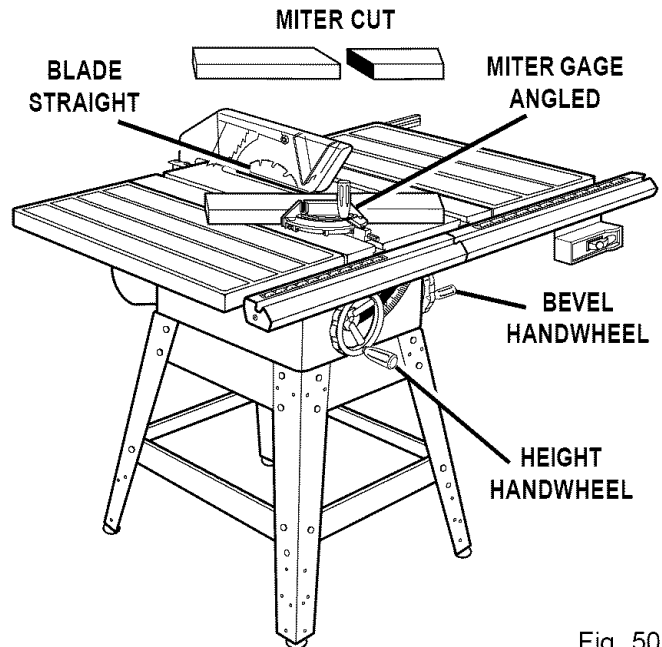

Fig. 50

MAKING A BEVEL CROSS CUT

See Figures 51 and 52.

Try out this cut on a piece of scrap wood before cutting your workpiece.

⚠ WARNING: Make sure the blade guard is lowered over blade and is working properly to prevent possible injury.

VIEWED FROM THE FRONT, BELOW THE TABLE SAW

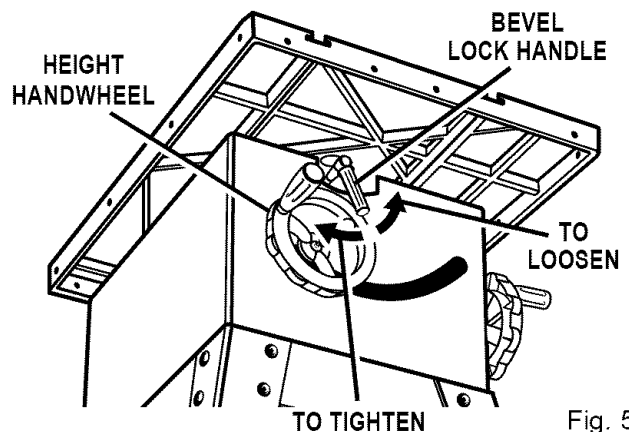

Fig. 51

OPERATION

- Raise the rip fence handle and remove the rip fence.
- Set the blade angle by loosening the bevel lock handle and turning the bevel handwheel. Retighten the bevel lock handle.
- Set miter gage to 0° if needed. Make sure miter gage knob is securely tightened.
- Place a support the same height as the top of the saw table behind the saw for the cut work.
- Make sure the wood is clear of the blade before turning on the saw. Insert the key and lift the switch to the **ON** position. Let the blade build up to full speed before feeding the wood into the blade with the miter gage.
- Hold the work firmly against the miter gage and push the miter gage to feed the work into the blade.
- When the work is completed, press the switch off and remove the key.

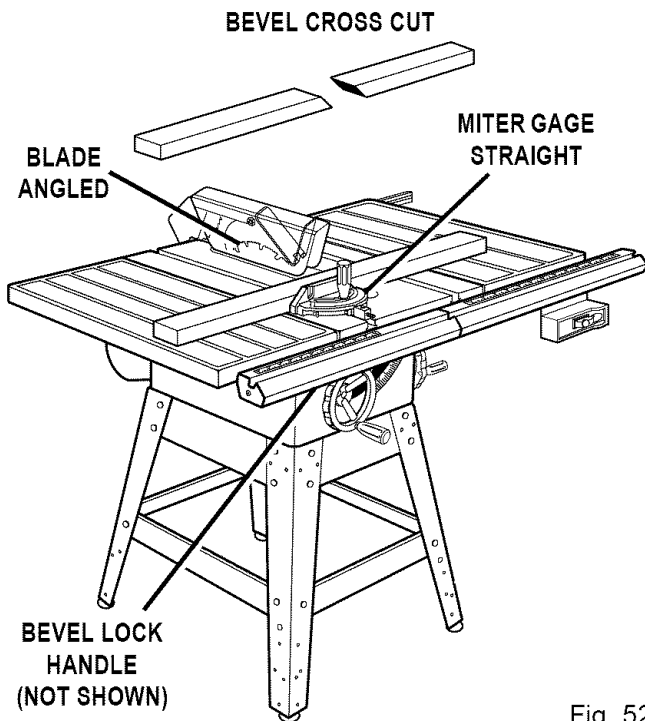

Fig. 52

MAKING A BEVEL RIP CUT

See Figure 53.

Try out this cut on a piece of scrap wood before cutting your workpiece. Use a pushstick to move small pieces of wood into and past the blade.

- ⚠ **WARNING:** Make sure the blade guard is lowered over blade and is working properly to prevent possible injury.

- Set the blade angle by loosening the bevel lock handle and turning the bevel handwheel. Retighten the bevel lock handle.

- ⚠ **WARNING:** When making a bevel rip cut, the rip fence must be on the right side of the blade. Otherwise the fence could trap the workpiece, possibly causing kickback and resulting in injury.

- Attach the rip fence on the right side of the blade at the correct distance from the blade for the cut.

- Place a support the same height as the top of the saw table behind the saw for the cut work.

- ⚠ **WARNING:** Never stand directly in the line of cut. Stand to the side to reduce the chance of injury should kickback occur.

- Make sure the wood is clear of the blade before turning on the saw. Insert the key and lift the switch to the **ON** position. Let the blade obtain full speed before feeding the workpiece into the blade.

- Place the work firmly against the rip fence and feed the work into the blade.

- ⚠ **WARNING:** Never push a small piece of wood into the blade with your hand. Use a pushstick as the end of the workpiece nears the blade.

- When the work is completed, press the switch off and remove the key.

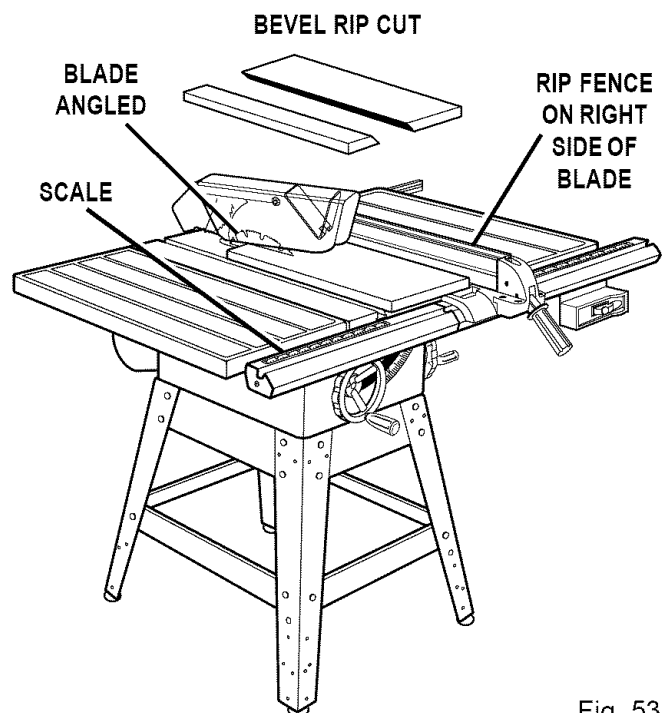

Fig. 53

OPERATION

MAKING A COMPOUND (BEVEL) MITER CUT

See Figure 54.

Practice on scrap wood. From the front of the saw, push the wood to the blade with the miter gage. Do not use the rip fence.

- ⚠ **WARNING:** Make sure the blade guard is lowered over blade and is working properly to prevent possible injury.
- Set the blade angle and height by loosening the bevel lock handle and turning the height and bevel handwheels. Retighten the bevel lock handle.
- ⚠ **WARNING:** When blade is angled to the left, the miter gage must be on the right side of the blade. Otherwise the gage could trap the workpiece, possibly causing kickback and resulting in injury.
- Set the wood angle by loosening the miter gage knob and setting it to the desired angle.
- Retighten miter gage knob.
- Place a support the same height as the top of the saw table behind the saw for the cut work.
- Make sure the wood is not touching the blade.
- Insert the key and lift the switch to the **ON** position. Let the blade build up to full speed.
- Hold the work firmly against the miter gage and push the miter gage to feed the work into the blade.
- When the work is completed, press the switch off and remove the key.

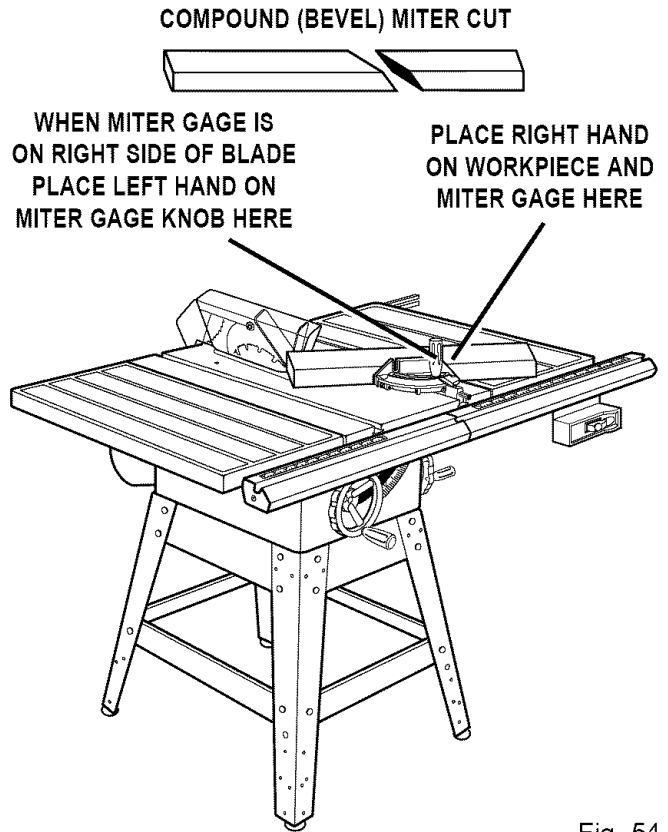

Fig. 54

OPERATION

MAKING A LARGE PANEL CUT

See Figure 55.

Make sure the saw is properly secured to a work surface to avoid tipping from the weight of a large panel.

- ⚠ **WARNING:** Make sure the blade guard is lowered over blade and is working properly to prevent possible injury.
- Place a support the same height as the top of the saw table behind the saw for the cut work. Add supports to the sides as needed.
- Depending on the shape of the panel, use the rip fence or miter gage. If the panel is too large to use either the rip fence or the miter gage, it is too large for this saw.

⚠ **WARNING:** Never make freehand cuts (cuts without the miter gage or rip fence), which can result in serious injury.

MAKING A NON-THROUGH CUT

See Figure 56.

This is the only type of cut made without the blade guard.

- ⚠ **WARNING:** Unplug the saw while removing or replacing the blade guard to prevent accidental starting and injury.
- Lift the blade guard out of the way.
- Adjust the blade angle and height by releasing the bevel lock handle and turning the height and bevel handwheels. Reset the bevel lock handle.
- Take out the throat plate by removing the screw with a phillips screwdriver. Remove the riving knife and guard assembly as shown. Be sure to reinstall it before moving to the next step.
- Place a support the same height as the top of the saw table behind the saw for the cut work. Add supports to the sides as needed.

⚠ **WARNING:** Always use pushsticks or pushblocks when making non-through cuts to avoid the risk of serious injury. Never feed wood with your hands.

- Make sure the wood is not touching the blade. Insert the key and lift the switch to the **ON** position. Let the blade build up to full speed before feeding the workpiece into the blade.
- When the work is completed, press the switch off and remove the switch key. Unplug the saw, then reinstall the riving knife and the blade guard.

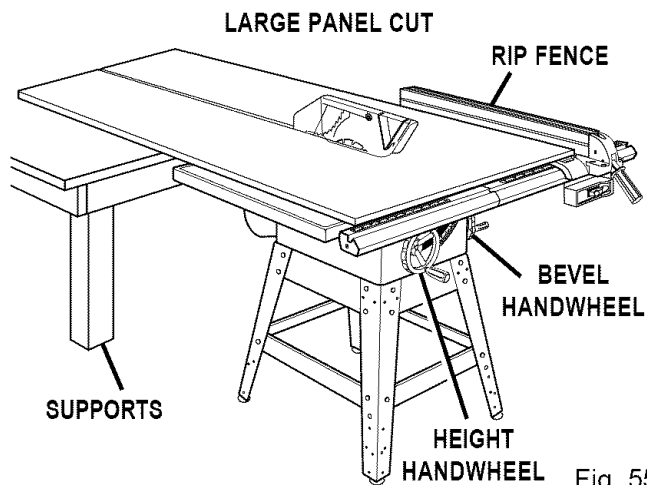

Fig. 55

- Make sure the wood does not touch the blade before you turn on the saw. Let the blade build up to full speed before feeding the wood into the blade.
- When the work is completed, press the switch off and remove the key.

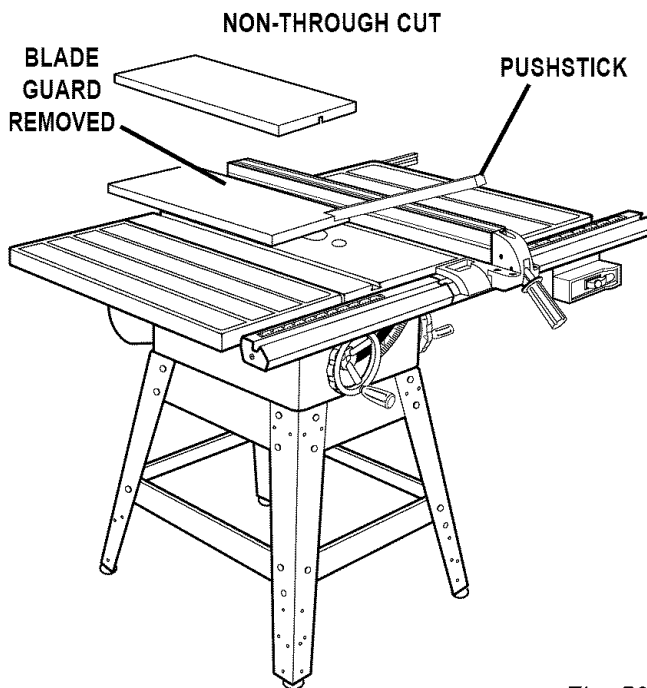

Fig. 56

OPERATION

MAKING A DADO CUT

See Figure 57.

An optional dado throat plate is required for this procedure. See the *Accessories* section of this manual and check with your nearest Sears Retail Store. All blades and dado sets must be rated at least 5,000 RPM.

⚠ WARNING: Unplug the saw before working around the blade. Accidental starting could cause serious injury.

- Take out the throat plate by loosening the screw.
- Remove the riving knife and guard assembly.
- Remove the blade.
- Mount the dado blade according to the instructions provided with it.
- Test the blade nut and blade washer tightness.
- Install optional dado throat plate.
- Plug in the saw and follow dado instructions. Always use pushsticks with dado cuts.
- When the work is completed, press the switch off and remove the key. Unplug the saw, remove the dado insert and dado blade. Reinstall the blade, riving knife, blade guard and throat plate.

DADO CUT

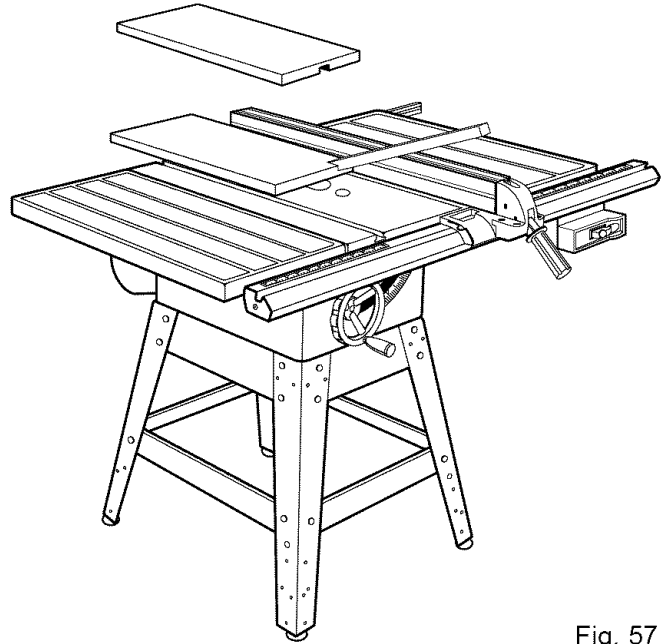

Fig. 57

⚠ WARNING: Never put your hands within 3 in. of the blade when it is on or you could be seriously hurt.

MAINTENANCE

GENERAL MAINTENANCE

⚠ WARNING: When servicing, use only identical Craftsman replacement parts. Use of any other part may create a hazard or cause product damage.

⚠ WARNING: To prevent accidental starting that could cause possible serious personal injury, turn off the saw, remove the switch key, and unplug the saw before working on the table saw.

- Remove sawdust from the rails, top surface, and inside of saw frequently.
- Clean plastic parts with a soft damp cloth. Do not use any strong solvents.

⚠ WARNING: Do not at any time let brake fluids, gasoline, petroleum-based products, penetrating oils, etc. contact plastic parts. They contain chemicals that can damage, weaken or destroy plastic.

- Periodically clean the table, rails, and rip fence with gum and pitch remover. Do not allow pitch to accumulate on the saw.
- Apply a thin coat of paste wax to the table top so the wood slides easily while cutting.
- Regularly check all nuts, bolts, screws, and belts for tightness and condition. Make sure the throat plate is in good condition.

MOTOR / ELECTRICAL

- Frequently vacuum or blow out any sawdust from the motor.

⚠ WARNING: If the power cord is worn, cut, or damaged in any way, have it replaced immediately by a qualified service technician at a Sears store or repair center. Failure to do so could result in serious personal injury.

⚠ WARNING: To avoid fire or electrocution, reassemble electric parts with only identical Craftsman replacement parts. Reassemble exactly as originally assembled.

LUBRICATION

This saw has been lubricated at the factory prior to shipment. After extended use, you should inspect, clean, and lubricate the areas shown in the drawing. Clean before lubricating with a solvent recommended for gum and pitch removal. Lubricate with SAE no. 20 or no. 30 engine oil.

See Figure 58.

- Table brackets. (a)
- Bevel handwheel rod threads and knuckle. (b)
- Height handwheel threads and trunnion. (c)

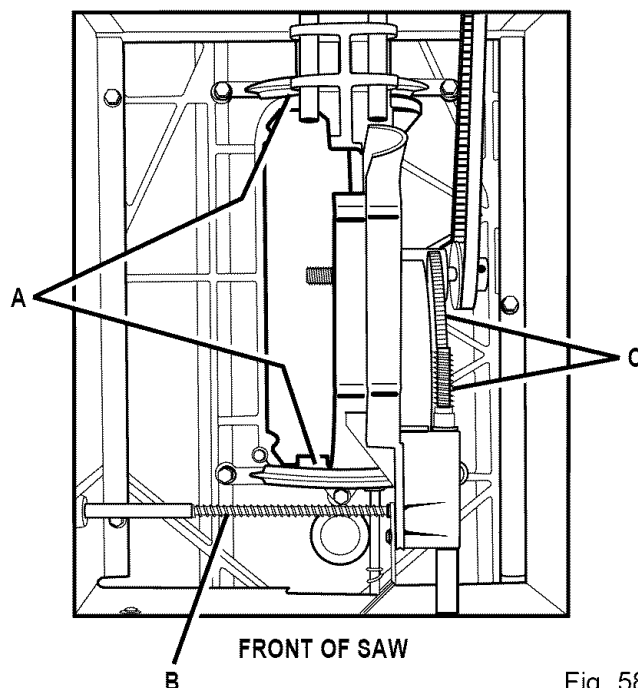

TROUBLESHOOTING

PROBLEM	CAUSE	SOLUTION
Saw does not start.	<ol style="list-style-type: none">1. Motor cord or wall cord is not plugged in.2. Circuit fuse is blown.3. Circuit breaker is tripped.4. Cord or switch is damaged.	<ol style="list-style-type: none">1. Plug in motor cord or wall cord.2. Replace circuit fuse.3. Reset circuit breaker.4. Have the cord or switch replaced at your nearest Sears Service Center.
Saw is noisy when running.	<ol style="list-style-type: none">1. Motor needs attention.	<ol style="list-style-type: none">1. Have the motor checked at your nearest Sears Service Center.
Motor is slow or weak.	<ol style="list-style-type: none">1. Voltage from source is low.2. Windings are burned out or open.3. Start switch is defective.4. Circuit is overloaded with appliances, lights, or other motors.	<ol style="list-style-type: none">1. Request a voltage check from the power company.2. Have the motor checked at your nearest Sears Service Center.3. Have the switch replaced.4. Do not use other appliances or motors on the same circuit when using the saw.
Motor overheats.	<ol style="list-style-type: none">1. Motor is overloaded.2. Dull blade.3. Sawdust inside saw is blocking air flow.	<ol style="list-style-type: none">1. Request a voltage check from the power company.2. Replace the blade.3. Clean out the saw base.
Motor stalls, blows fuses, or trips circuit breakers.	<ol style="list-style-type: none">1. Starter switch is defective.2. Voltage from source is low.3. Dull blade.4. Fuses or circuit breakers are wrong size or defective.5. Feeding workpiece too rapidly.	<ol style="list-style-type: none">1. Have the switch replaced.2. Request a voltage check from the power company.3. Replace the blade.4. Replace fuses or circuit breakers.5. Feed workpiece into blade slower.

TROUBLESHOOTING

PROBLEM	CAUSE	SOLUTION
Fuses or circuit breakers open frequently.	<ol style="list-style-type: none"> 1. Motor is overloaded. 2. Fuses or circuit breakers are wrong size or defective. 3. Dull blade. 4. Start switch is defective. 	<ol style="list-style-type: none"> 1. Feed work more slowly. 2. Replace fuses or circuit breakers. 3. Replace the blade. 4. Have the switch replaced.
Saw vibrates excessively.	<ol style="list-style-type: none"> 1. Blade is warped. 2. Belt is damaged. 3. Saw is not mounted securely. 4. Work surface is uneven. 	<ol style="list-style-type: none"> 1. Replace the blade. 2. Replace the belt. 3. Tighten all hardware. 4. Reposition on a flat surface. Adjust the leveling feet on legs.
Start switch does not operate.	<ol style="list-style-type: none"> 1. Switch contacts are burned out. 2. Capacitor is defective 3. Connections are loose or damaged. 	<ol style="list-style-type: none"> 1. Have the switch replaced and request a voltage check from the power company. 2. Have the capacitor replaced. 3. Have the wiring checked and repaired.
Handwheels are hard to turn.	<ol style="list-style-type: none"> 1. Sawdust has collected on the mechanism inside saw. 	<ol style="list-style-type: none"> 1. Clean and lubricate the mechanism.
Blade does not lower when turning height handwheel.	<ol style="list-style-type: none"> 1. Blade lock handle is not fully released. 	<ol style="list-style-type: none"> 1. Fully release the blade lock handle.
Miter gage does not move smoothly.	<ol style="list-style-type: none"> 1. Miter gage assembly is dirty or sticky. 	<ol style="list-style-type: none"> 1. Release the miter gage knob and wax the miter gage base and sides.
Cut binds, burns or stalls motor when ripping.	<ol style="list-style-type: none"> 1. Blade or teeth are dull. 2. Blade is heeling. 3. Board is warped. 4. Rip fence does not parallel blade. 	<ol style="list-style-type: none"> 1. Sharpen or replace the blade. 2. See <i>Heeling the Sawblade</i> in the <i>Adjustments</i> section. 3. Replace the board. 4. See <i>Aligning the Rip Fence</i> in the <i>Assembly</i> section.
Saw blade does not cut true at 90° or 45° positions.	<ol style="list-style-type: none"> 1. Indicators are not properly adjusted. 2. Positive stops inside base are not accurate. 	<ol style="list-style-type: none"> 1. See <i>Setting the Bevel Stops and Indicator</i> in the <i>Adjustments</i> section. 2. See <i>Setting the Bevel Stops and Indicator</i> in the <i>Adjustments</i> section.

TROUBLESHOOTING

PROBLEM	CAUSE	SOLUTION
Rip fence does not move smoothly.	<ol style="list-style-type: none">1. Rip fence is not mounted correctly.2. Rails are dirty or sticky.	<ol style="list-style-type: none">1. Remove and reposition the rip fence. See <i>Aligning Rip Fence and Front Rail</i> in the <i>Assembly</i> section.2. Clean and wax the rails.
Wood edges away from rip fence when ripping.	<ol style="list-style-type: none">1. Rip fence is misaligned.	<ol style="list-style-type: none">1. See the <i>Assembly</i> section for <i>Checking Rip Fence and Blade Alignment</i> and <i>Aligning Rip Fence and Front Rail</i> procedures.

CRAFTSMAN TABLE SAW – MODEL NO. 315.228390

The model number will be found on a plate attached to the cabinet. Always mention the model number in all correspondence regarding your **TABLE SAW** or when ordering repair parts.

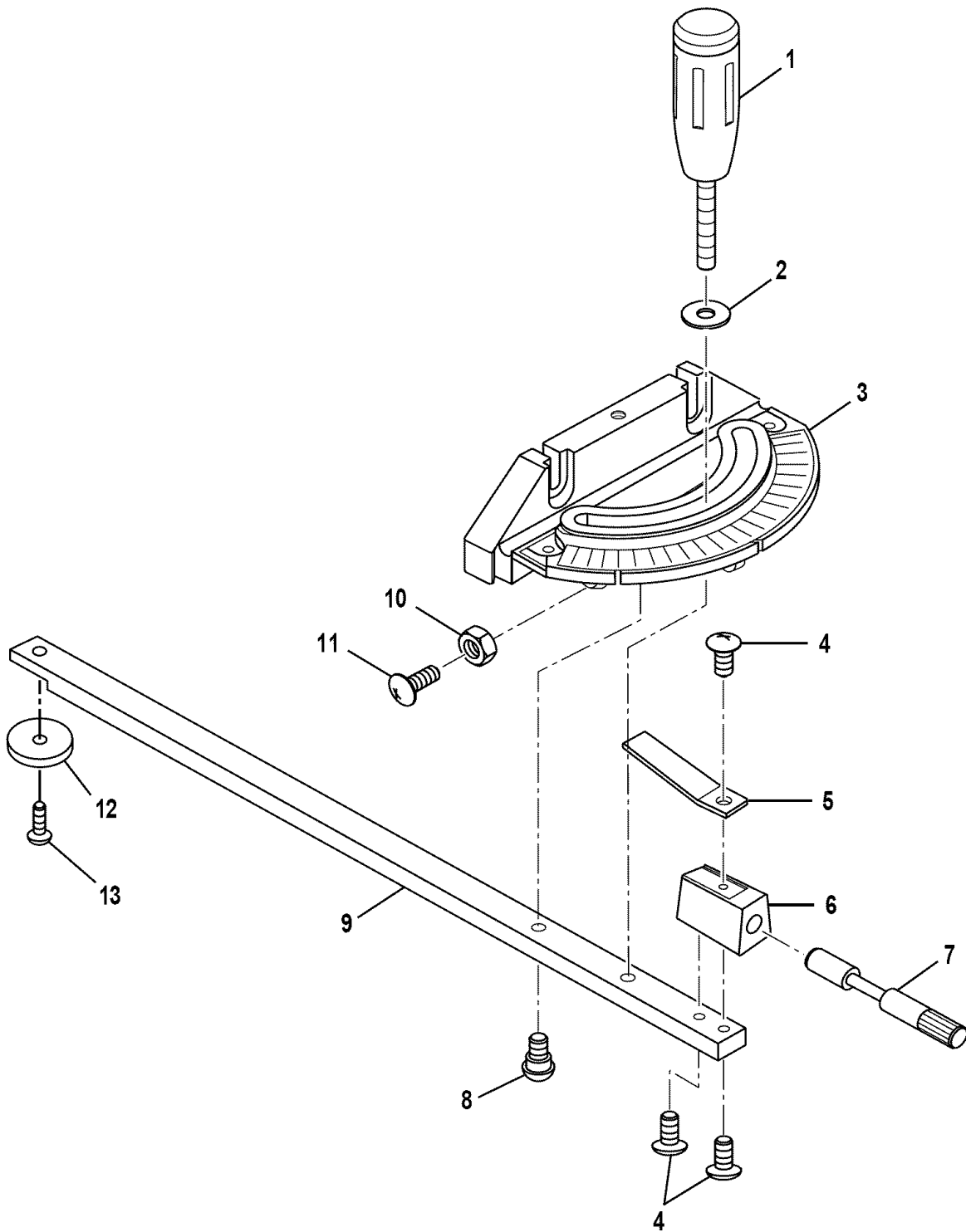

FIGURE A

The model number will be found on a plate attached to the cabinet. Always mention the model number in all correspondence regarding your **TABLE SAW** or when ordering repair parts.

PARTS LIST FOR FIGURE A

KEY NO.	PART NUMBER	DESCRIPTION	QUAN.
1	982072-001	Miter Gage Knob	1
2	** STD551031	* Washer (5/16 in.)	1
3	982085-001	Miter Gage	1
4	** STD511003	* Screw (#10-24 x 3/8 in.)	3
5	979978-001	Miter Scale Indicator	1
6	979979-001	Miter Gage Block	1
7	979980-001	Stop Pin	1
8	979984-001	Shoulder Screw	1
9	979981-002	Miter Gage Rod	1
10	** STD510807	* Screw (#8-32 x 5/8 in.)	3
11	** STD541008	* Hex Nut (#8-32)	3
12	982087-001	Sliding Washer	1
13	982088-001	* Screw (1/4-20 x 1/4 in. Flat Head)	1
	981284-001	Complete Miter Gage Assembly (Includes Key Nos. 1-13)	

* Standard Hardware Item — May Be Purchased Locally
 ** Available From Div. 98 — Source 980.00

CRAFTSMAN TABLE SAW – MODEL NO. 315.228390

The model number will be found on a plate attached to the cabinet. Always mention the model number in all correspondence regarding your **TABLE SAW** or when ordering repair parts.

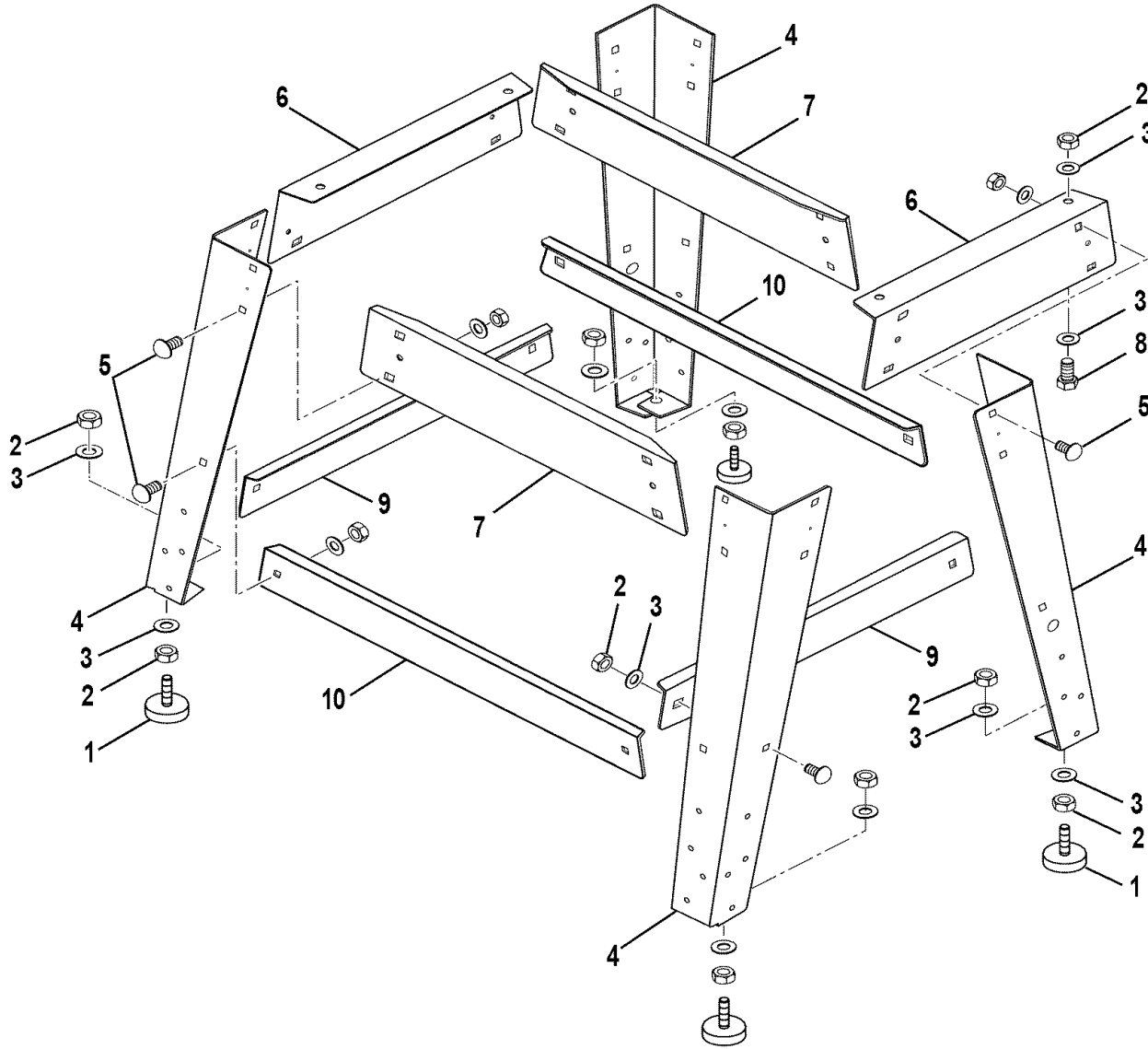

FIGURE B

CRAFTSMAN TABLE SAW – MODEL NO. 315.228390

The model number will be found on a plate attached to the cabinet. Always mention the model number in all correspondence regarding your **TABLE SAW** or when ordering repair parts.

PARTS LIST FOR FIGURE B

KEY NO.	PART NUMBER	DESCRIPTION	QUAN.
1	979999-001	Leveling Foot	4
2	** STD541031	* Hex Nut (5/16-18)	36
3	** STD551031	* Washer (5/16 in.)	40
4	979995-002	Leg	4
5	** STD533107	* Carriage Bolt (5/16-18 x 3/4 in.)	24
6	979993-002	End Brace	2
7	979997-002	Side Brace	2
8	** STD523107	* Bolt (5/16-18 x 3/4 in. Hex Hd.)	4
9	979996-002	Short Leg Brace	2
10	979998-002	Long Leg Brace	2

*Standard Hardware Item — May Be Purchased Locally

**Available From Div. 98 — Source 980.00

CRAFTSMAN TABLE SAW – MODEL NO. 315.228390

The model number will be found on a plate attached to the cabinet. Always mention the model number in all correspondence regarding your **TABLE SAW** or when ordering repair parts.

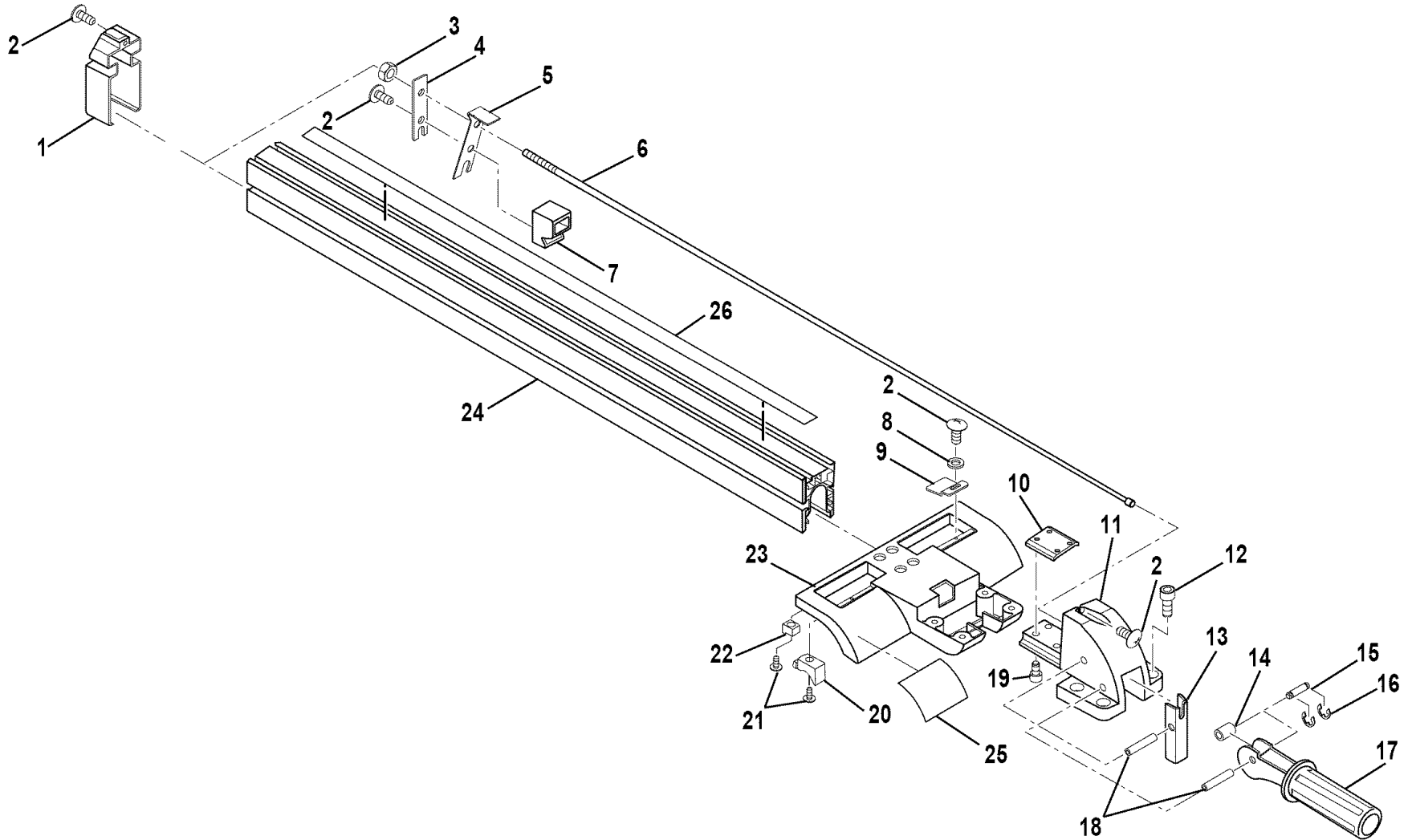

FIGURE C

CRAFTSMAN TABLE SAW – MODEL NO. 315.228390

The model number will be found on a plate attached to the cabinet. Always mention the model number in all correspondence regarding your **TABLE SAW** or when ordering repair parts.

PARTS LIST FOR FIGURE C

KEY NO.	PART NUMBER	DESCRIPTION	QUAN.	KEY NO.	PART NUMBER	DESCRIPTION	QUAN.
1	979973-001	Fence End Cap	1	14	980964-001	Cam Sleeve	1
2	979945-001	* Screw (#8-32 x 1/2 in.)	4	15	980595-001	Pin	1
3	** STD541425	* Lock Nut (1/4-20)	1	16	980596-001	Retaining Ring	2
4	979970-001	Lock Plate	1	17	979965-002	Rip Fence Handle	1
5	979969-001	Lock Spring	1	18	979966-001	Roll Pin (8 x 43 mm)	2
6	979968-001	Fence Lock Rod	1	19	979967-001	* Screw (1/4-20 x 3/4 in. Socket Hd.)	4
7	979972-001	Rear Fence Slide	1	20	980966-001	Rear Glide	2
8	** STD551008	* Washer (#8)	1	21	980598-001	* Screw (#8-32 x 1/4 in.)	4
9	979961-001	Scale Indicator	1	22	980965-001	Front Glide	2
10	979962-001	Fence Plate	1	23	979960-001	Scale Indicator Housing	1
11	979963-001	Rip Fence Cover	1	24	979959-001	Rip Fence	1
12	979881-001	* Screw (5/16-18 x 1/2 in. Socket Hd.) ...	4	25	980322-001	Warning Label	1
13	979964-001	Fence Handle Bracket	1	26	980317-001	Fence Label	1
					981281-001	Complete Rip Fence Assembly (Includes Key Nos. 1-26)	

*Standard Hardware Item — May Be Purchased Locally

**Available From Div. 98 — Source 980.00

CRAFTSMAN TABLE SAW – MODEL NO. 315.228390

The model number will be found on a plate attached to the cabinet. Always mention the model number in all correspondence regarding your **TABLE SAW** or when ordering repair parts.

PARTS LIST FOR FIGURE D

KEY NO.	PART NUMBER	DESCRIPTION	QUAN.
1	979935-001	Push Nut	4
2	979940-001	Anti-Kickback Pawl	2
3	979944-001	Spacer	2
4	** STD551025	* Washer (1/4 in.)	3
5	979942-001	* Screw (1/4-20 x 3/8 in. Socket Hd.)	3
6	979941-001	Riving Knife	1
7	979937-001	Blade Guard Bracket	1
8	979939-001	Spring	1
9	979938-001	Pin	1
10	979934-001	Blade Guard	1
11	979936-001	Pin	1
12	980955-001	Roll Pin	1
13	980400-001	Warning Label	1
14	980324-001	Blade Guard Label	1
	981279-001	Blade Guard Assembly (Includes Key Nos. 1-14)	

*Standard Hardware Item — May Be Purchased Locally

**Available From Div. 98 — Source 980.00

CRAFTSMAN TABLE SAW – MODEL NO. 315.228390

The model number will be found on a plate attached to the cabinet. Always mention the model number in all correspondence regarding your **TABLE SAW** or when ordering repair parts.

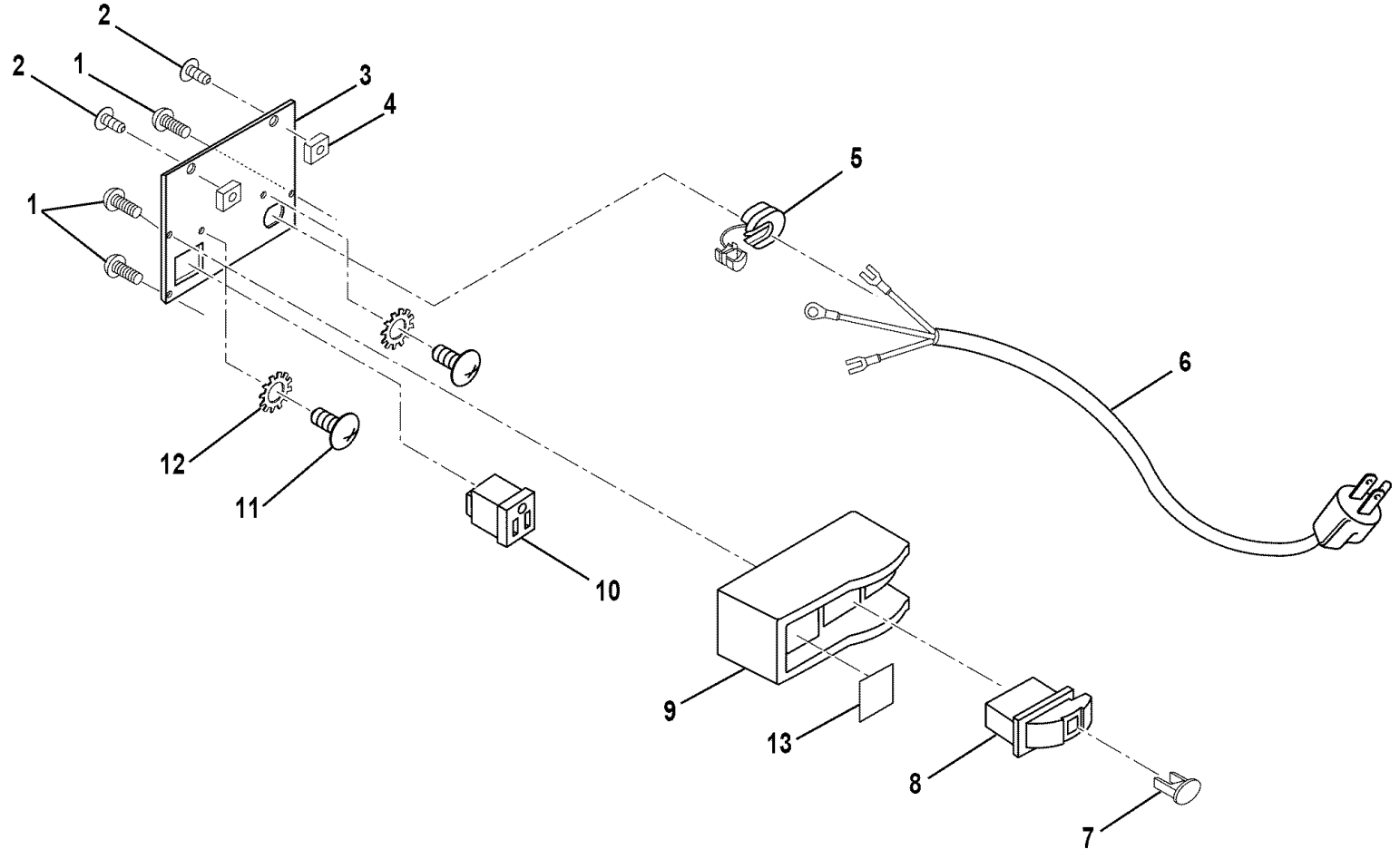

FIGURE E

CRAFTSMAN TABLE SAW – MODEL NO. 315.228390

The model number will be found on a plate attached to the cabinet. Always mention the model number in all correspondence regarding your **TABLE SAW** or when ordering repair parts.

PARTS LIST FOR FIGURE E

KEY NO.	PART NUMBER	DESCRIPTION	QUAN.
1	979945-001	* Screw (#8-32 x 1/2 in.)	3
2	** STD512503	* Screw (1/4-20 x 3/8 in.)	2
3	979985-001	Switch Plate	1
4	980594-001	* Square Nut (1/4-20)	2
5	979986-001	Strain Relief	1
6	979991-001	Power Cord (Power Source)	1
7	976863-001	Switch Key	1
8	980001-001	Switch (Includes Key No. 7)	1
9	979987-001	Switch Housing	1
10	980000-001	Receptacle	1
11	** STD511003	* Screw (#10-24 x 5/16 in.)	2
12	979990-001	* Star Washer (#10)	2
13	980321-001	On/Off Label	1
	982516-001	Switch Assembly (Includes Key Nos. 1-13)	

*Standard Hardware Item — May Be Purchased Locally

**Available From Div. 98 — Source 980.00

CRAFTSMAN TABLE SAW – MODEL NO. 315.228390

The model number will be found on a plate attached to the cabinet. Always mention the model number in all correspondence regarding your **TABLE SAW** or when ordering repair parts.

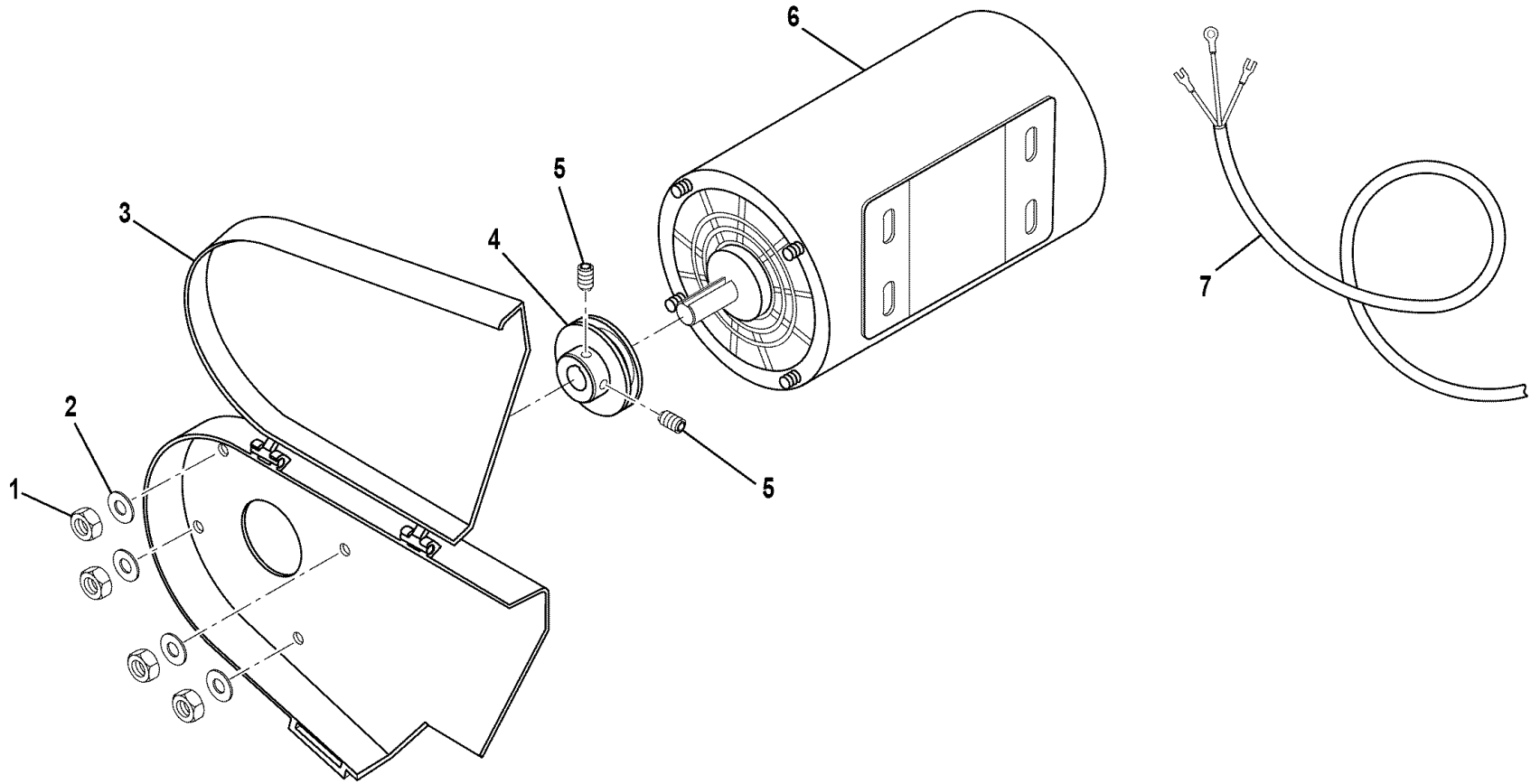

FIGURE F

CRAFTSMAN TABLE SAW – MODEL NO. 315.228390

The model number will be found on a plate attached to the cabinet. Always mention the model number in all correspondence regarding your **TABLE SAW** or when ordering repair parts.

PARTS LIST FOR FIGURE F

KEY NO.	PART NUMBER	DESCRIPTION	QUAN.
1	** STD541010	* Hex Nut (#10)	4
2	** STD551010	* Flat Washer (#10)	4
3	981382-001	Belt Guard	1
4	979900-001	Pulley	1
5	** STD502502	* Setscrew (1/4-20 x 1/4 in.)	2
6	979931-001	Motor	1
7	979988-001	Power Cord (Motor)	1

*Standard Hardware Item — May Be Purchased Locally

**Available From Div. 98 — Source 980.00

CRAFTSMAN TABLE SAW – MODEL NO. 315.228390

The model number will be found on a plate attached to the cabinet. Always mention the model number in all correspondence regarding your **TABLE SAW** or when ordering repair parts.

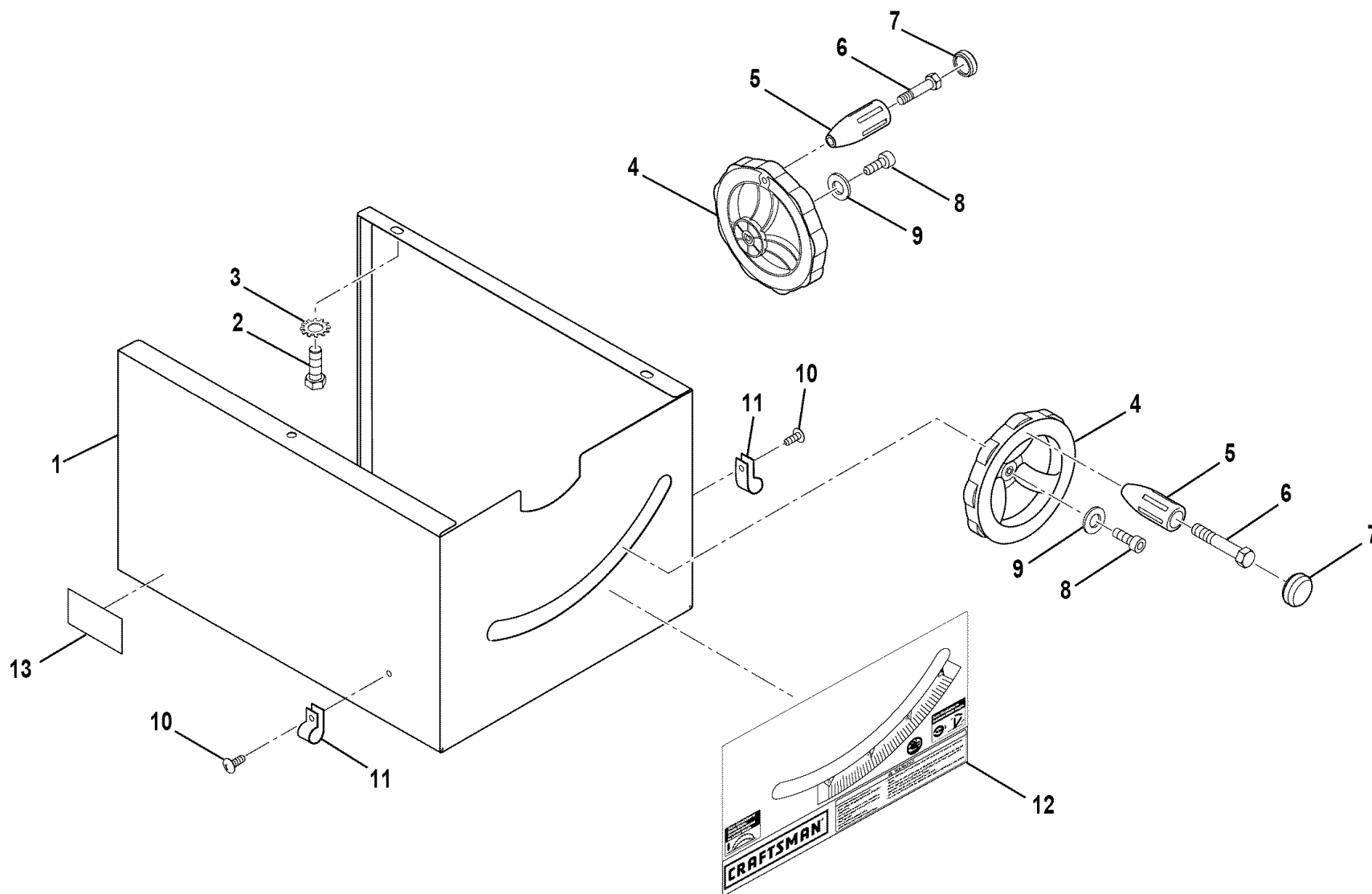

FIGURE G

CRAFTSMAN TABLE SAW – MODEL NO. 315.228390

The model number will be found on a plate attached to the cabinet. Always mention the model number in all correspondence regarding your **TABLE SAW** or when ordering repair parts.

PARTS LIST FOR FIGURE G

KEY NO.	PART NUMBER	DESCRIPTION	QUAN.
1	979992-002	Base	1
2	** STD523105	* Bolt (5/16-18 x 1/2 in. Hex Hd.)	3
3	980588-001	* Star Washer (5/16 in.)	3
4	979918-002	Handwheel Assembly (Includes Key Nos. 5, 6, and 7).....	2
5	977229-002	Handle	2
6	977491-001	Screw (M8 x 1-1/4 in.)	2
7	977481-001	End Cap	2
8	980602-001	* Screw (#10-24 x 1/2 in. Socket Hd.)	2
9	** STD551010	* Washer (#10)	2
10	** STD511005	* Screw (#10)	2
11	980599-001	Cord Clip	2
12	980320-002	Front Panel Label	1
13	982082-001	Data Plate	1

*Standard Hardware Item — May Be Purchased Locally
 **Available From Div. 98 — Source 980.00

CRAFTSMAN TABLE SAW – MODEL NO. 315.228390

The model number will be found on a plate attached to the cabinet. Always mention the model number in all correspondence regarding your **TABLE SAW** or when ordering repair parts.

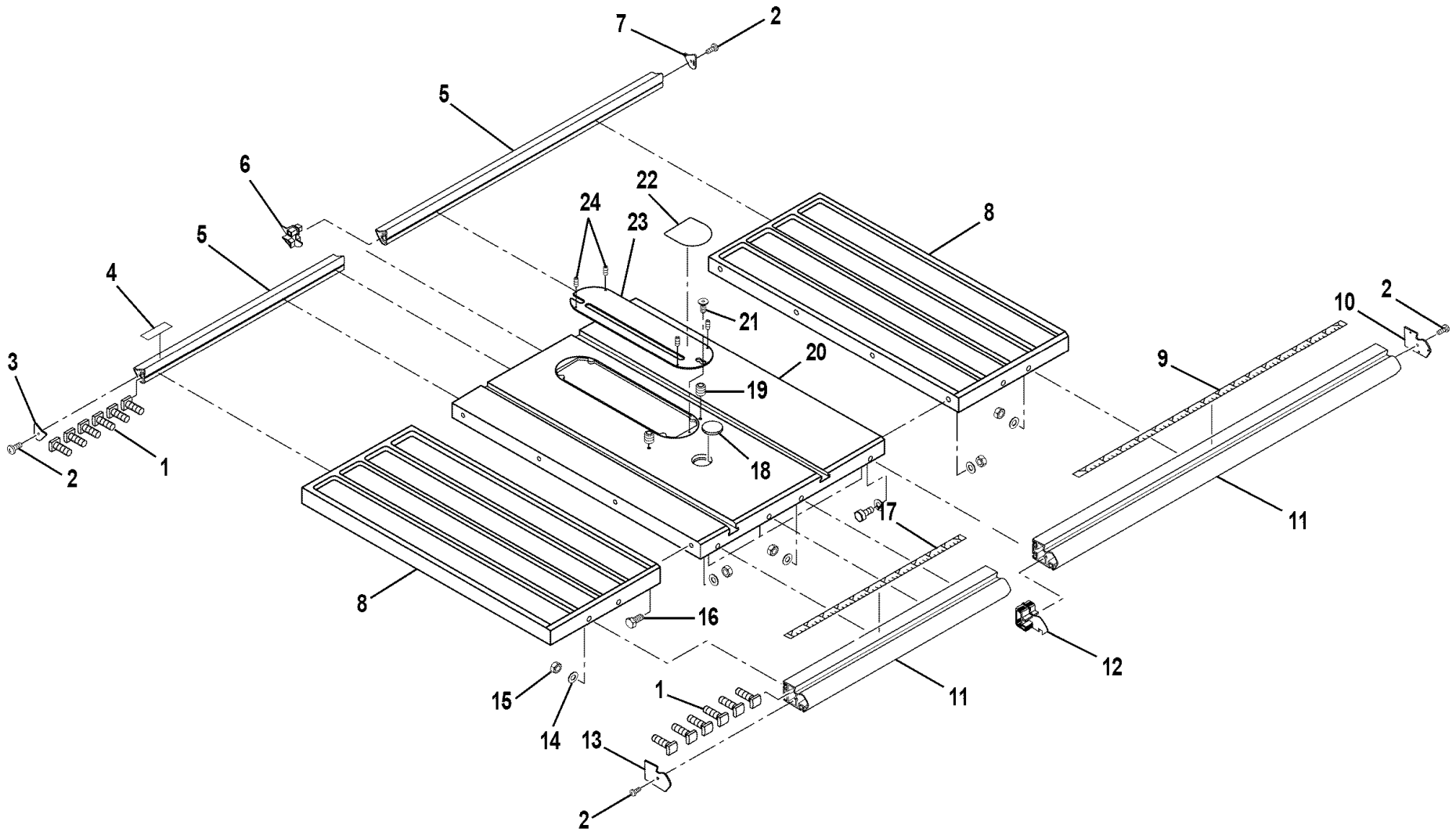

FIGURE H

CRAFTSMAN TABLE SAW – MODEL NO. 315.228390

The model number will be found on a plate attached to the cabinet. Always mention the model number in all correspondence regarding your **TABLE SAW** or when ordering repair parts.

PARTS LIST FOR FIGURE H

KEY NO.	PART NUMBER	DESCRIPTION	QUAN.
1	979879-001	* Bolt (5/16-18 x 3/4 in. Square Hd.).....	12
2	979945-001	* Screw (#8-32 x 1/2 in.)	4
3	979946-001	End Cap (Left Rear)	1
4	980323-001	Label	1
5	979947-001	Rear Rail (One Piece Design)	1
6	982084-001	Rear Rail Connector (For Use On Split Rail Design).....	1
7	979948-001	End Cap (Right Rear)	1
8	979870-002	Extension Table	2
9	982081-001	Scale (Right)	1
10	979951-001	End Cap (Right Front)	1
11	979950-001	Front Rail (One Piece Design, Includes Scale)	1
12	982083-001	Front Rail Connector (For Use On Split Rail Design)	1
13	979949-001	End Cap (Left Front)	1
14	** STD551131	* Washer (5/16 in.)	28
15	** STD541031	* Hex Nut (5/16-18)	20
16	** STD523110	* Bolt (5/16-18 x 1 in. Hex Hd.)	8
17	982080-001	Scale (Left)	1
18	979875-001	Align-A-Cut Insert	1
19	979874-001	* Setscrew (5/16-18 x 5/8 in.)	2
20	980956-002	Saw Table	1
21	979872-001	* Screw (#10-24 x 3/4 in.)	1
22	982099-001	Throat Plate Label	1
23	979871-001	Throat Plate	1
24	979873-001	* Setscrew (#10-24 x 3/16 in.)	4

*Standard Hardware Item — May Be Purchased Locally

**Available From Div. 98 — Source 980.00

CRAFTSMAN TABLE SAW – MODEL NO. 315.228390

The model number will be found on a plate attached to the cabinet. Always mention the model number in all correspondence regarding your **TABLE SAW** or when ordering repair parts.

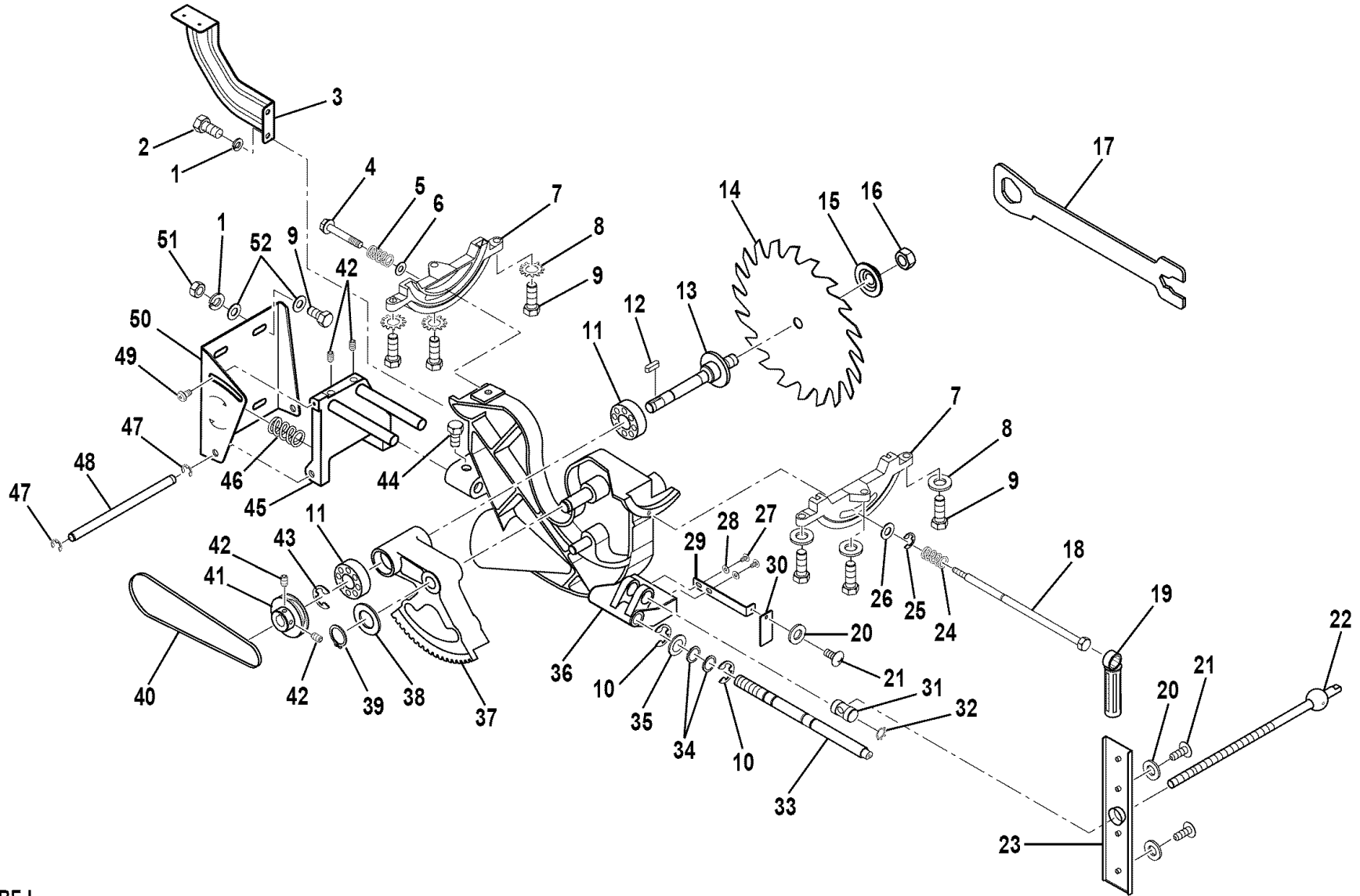

FIGURE I

CRAFTSMAN TABLE SAW – MODEL NO. 315.228390

The model number will be found on a plate attached to the cabinet. Always mention the model number in all correspondence regarding your **TABLE SAW** or when ordering repair parts.

PARTS LIST FOR FIGURE I

KEY NO.	PART NUMBER	DESCRIPTION	QUAN.	KEY NO.	PART NUMBER	DESCRIPTION	QUAN.
1	** STD551131	* Lock Washer (5/16 in.)	6	27	** STD511003	* Screw (#10-24 x 3/8 in.)	2
2	** STD523105	* Bolt (5/16-18 x 1/2 in. Hex Hd.)	2	28	980946-001	* Washer (#10)	2
3	979880-001	Blade Guard Bracket	1	29	979908-001	Bracket	1
4	979883-001	* Bolt (1/4-20)	1	30	979911-001	Bevel Scale Indicator	1
5	979884-001	Spring	1	31	979914-001	Knuckle	1
6	980600-001	Washer	1	32	980589-001	Retaining Ring	1
7	979886-001	Table Bracket	2	33	979924-001	Height Adjustment Rod	1
8	980588-001	Star Washer	6	34	979923-001	"O" Ring	2
9	** STD523110	* Bolt (5/16-18 x 1 in. Hex Hd.)	10	35	979922-001	Washer	1
10	979896-001	Retaining Ring	2	36	979897-001	Cradle (Trunnion)	1
11	979895-001	Ball Bearing (6202Z)	2	37	979898-001	Arbor Housing	1
12	979894-001	Key	1	38	979902-001	Washer	1
13	979893-001	Arbor Shaft	1	39	979903-001	Retaining Ring	1
14	***	10 in. Blade (Item No. 9 32126)	1	40	** STD304420	V-Belt (4L-420)	1
15	979891-001	Outer Blade Washer	1	41	979900-001	Pulley	1
16	979890-001	Blade Nut	1	42	** STD502502	* Setscrew (1/4-20 x 1/4 in.)	4
17	979889-001	Blade Wrench	1	43	980593-001	Retaining Ring	1
18	979906-001	Shaft	1	44	** STD523107	* Bolt (5/16-18 x 3/4 in. Hex Hd.)	2
19	979907-002	Bevel Lock Handle	1	45	979925-001	Motor Support Base	1
20	979912-001	* Washer (#8)	5	46	979926-001	Spring	1
21	979910-001	* Screw (#8-32 x 3/8 in.)	5	47	979904-001	Retaining Ring	2
22	979917-001	Threaded Rod	1	48	979927-001	Pivot Shaft	1
23	979915-001	Bracket	1	49	979928-001	Screw	1
24	979905-001	Spring	1	50	979929-001	Motor Mounting Plate	1
25	979904-001	Retaining Ring	1	51	** STD541031	* Hex Nut (5/16-18)	4
26	979885-001	Washer	1	52	** STD551031	* Washer (5/16 in.)	8
					972000-780	Owner's Manual	

* Standard Hardware Item — May Be Purchased Locally ** Available From Div. 98 — Source 980.00

*** Complete Assortment Available At Your Nearest Sears Retail Store

Get it fixed, at your home or ours!

For repair of major brand appliances **in your own home...**
no matter who made it, no matter who sold it!

1-800-4-MY-HOMESM Anytime, day or night
(1-800-469-4663)

www.sears.com

To bring in products such as vacuums, lawn equipment and electronics
for repair, call for the location of your nearest **Sears Parts & Repair Center.**

1-800-488-1222 Anytime, day or night

www.sears.com

For the replacement parts, accessories and owner's manuals
that you need to do-it-yourself, call **Sears PartsDirectSM!**

1-800-366-PART 6 a.m. – 11 p.m. CST,
(1-800-366-7278) 7 days a week

www.sears.com/partsdirect

To purchase or inquire about a Sears Service Agreement:

1-800-827-6655

7 a.m. – 5 p.m. CST, Mon. – Sat.

Para pedir servicio de reparación a domicilio,
y para ordenar piezas con entrega a domicilio:

1-888-SU-HOGARSM
(1-888-784-6427)

Au Canada pour service en français:

1-877-LE-FOYERSM
(1-877-533-6937)

