

SEARS

OWNERS MANUAL

MODEL NO.
917.254630

Caution:
Read and Follow
All Safety Rules
And Instructions
Before Operating
This Equipment

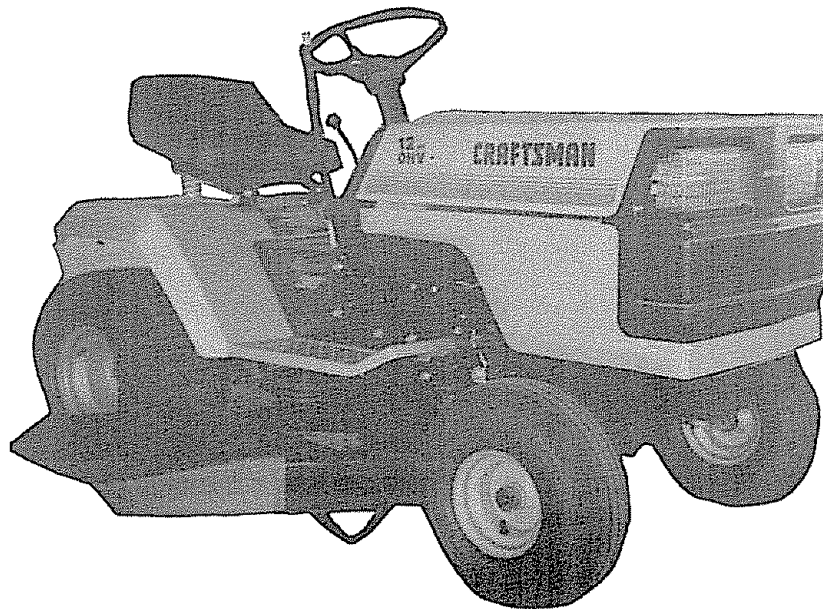

CRAFTSMAN

**LT 12 HP ELECTRIC START
4 SPEED - 38" MOWER
LAWN TRACTOR**

- **Assembly**
- **Operation**
- **Maintenance**
- **Repair and Adjustment**
- **Repair Parts**



LOOK FOR THIS SYMBOL TO POINT OUT IMPORTANT SAFETY PRECAUTIONS. IT MEANS - ATTENTION! BECOME ALERT! YOUR SAFETY IS INVOLVED.

CAUTION: LOOK FOR THIS WORD TO POINT OUT IMPORTANT EQUIPMENT PRECAUTIONS.



RULES FOR SAFE OPERATION

WARNING: This unit is equipped with an internal combustion engine and should not be used on or near any unimproved forest-covered brush-covered or grass covered land unless the engine's exhaust system is equipped with a spark arrester meeting applicable local or area laws (if any). If a spark arrester is used, it should be maintained in effective working order by the operator. (See REPAIR PARTS for part number identification).

In the State of California the above is required by law (Section 4442 of the California Public Resources Code). Other States may have similar laws. Federal laws apply on federal lands.

1. Know the controls and how to stop quickly. READ THIS OPERATOR'S MANUAL and instructions furnished with attachments.
2. Do not allow children to operate the machine. Do not allow adults to operate it without proper instruction.
3. Do not carry passengers. Do not mow when children and others are around.
4. Always wear substantial footwear. Do not wear loose fitting clothing that could get caught in moving parts.
5. Keep your eyes and mind on your tractor, mower, and the area being cut. Do not let other interests distract you.
6. Do not attempt to operate your tractor or mower when not in the drivers seat.
7. Always get on or off your tractor from the operator's left hand side.
8. Clear the work area of objects (wire, rocks, etc.) which might be picked up and thrown.
9. Disengage all attachment clutches before attempting to start the engine.
10. Disengage power to attachments and stop the engine before leaving the operator's position.
11. Disengage power to mower, stop the engine, and disconnect spark plug wire(s) from spark plug(s) before cleaning, making an adjustment, or repair. Be careful to avoid touching hot muffler or engine components.
12. Disengage power to attachments when transporting or not in use.
13. Take all possible precautions when leaving the vehicle unattended. Disengage the power-take-off, lower the attachments, shift into neutral, set the parking brake, stop the engine, and remove the key.
14. Do not stop or start suddenly when going uphill or downhill. Mow up and down the face of slopes (not greater than 15°); never across the face. Refer to page 37.
15. Reduce speed on slopes and make turns gradually to prevent tipping or loss of control. Exercise extreme caution when changing direction on slopes.
16. While going up or down slopes, place Gear Shift Control Lever in 1st gear position to negotiate the slope without stopping.
17. Never mow in wet or slippery grass, when traction is unsure, or at a speed which could cause a skid.
18. Stay alert for holes in the terrain and other hidden hazards. Keep away from drop-offs.
19. Do not drive too close to creeks, ditches, and public highways.
20. Exercise special care when mowing around fixed objects in order to prevent the blades from striking them. Never deliberately run tractor or mower into or over any foreign objects.
21. Never shift gears until tractor comes to a stop.
22. Never place hands or feet under the mower, in discharge chute, or near any moving parts while tractor or mower are running. Always keep clear of discharge chute.
23. Use care when pulling loads or using heavy equipment.
 - a. Use only approved drawbar hitch points.
 - b. Limit loads to those you can safely control.
 - c. Do not turn sharply. Use care when backing.
 - d. Use counterweight or wheel weights when suggested owner's manuals.
24. Watch out for traffic when crossing or near roadways.
25. When using any attachments, never direct discharge material toward bystanders nor allow anyone near the vehicle while in operation.
26. Handle gasoline with care - it is highly flammable.
 - a. Use approved gasoline containers.
 - b. Never remove the fuel cap of the fuel tank or add gasoline to a running or hot engine or an engine that has not been allowed to cool for several minutes after running. Never fill tank indoors, always clean up spilled gasoline.
 - c. Open doors if the engine is run in the garage - exhaust fumes are dangerous. Do not run the engine indoors.
27. Keep the vehicle and attachments in good operating condition, and keep safety devices in place and working.
28. Keep all nuts, bolts, and screws tight to be sure the equipment is in safe working condition.
29. Never store the equipment with gasoline in the tank inside building where fumes may reach an open flame or spark. Allow the engine to cool before storing in any enclosure.
30. To reduce fire hazard, keep the engine free of grass, leaves or excessive grease. Do not clean product while engine is running.
31. Except for adjustments, DO NOT operate Engine if a cleaner or cover directly over carburetor air intake is removed. Removal of such part could create a fire hazard.
32. Do not operate without a muffler, or tamper with exhaust system. Damaged mufflers or spark arresters could create a fire hazard. Inspect periodically and replace if necessary.
33. The vehicle and attachments should be stopped and inspected for damage after striking a foreign object, and the damage should be repaired before restarting and operating the equipment.
34. Do not change the engine governor settings or overspeed the engine; severe damage or injury may result.
35. When using the vehicle with mower, proceed as follows:
 - a. Mow only in daylight or in good artificial light.
 - b. Shut the Engine off when unclogging chute.
 - c. Check the blade mounting bolts for proper tightness at frequent intervals.
36. Do not operate the mower without either the entire grass catcher, on mowers so equipped, or the the deflector shield in place.
37. Disengage power to mower before backing up. Do not move in reverse unless absolutely necessary and then only after careful observation of the entire area behind the mower.
38. Under normal usage the grass catcher bag material is subject to deterioration and wear. It should be checked frequently for bag replacement. Replacement bags should be checked to ensure compliance with the original manufacturer's recommendations or specifications.

CONGRATULATIONS on your purchase of a Sears Lawn Tractor. It has been designed, engineered and manufactured to give you the best possible dependability and performance. Should you experience any problem you cannot easily remedy, please contact your nearest Sears Service Department. We have competent, well-trained technicians and the proper tools to service or repair this unit.

MAINTENANCE AGREEMENT

A Sears Maintenance Agreement is available on this product. See the nearest Sears store or service center for details.

CUSTOMER RESPONSIBILITIES

Read and retain this manual. Study and observe the safety rules. Always use care when using your tractor. Always keep your tractor and mower clean. Follow a regular schedule in maintaining, caring for, and using your tractor. A well cared for tractor will run better and last longer.

ATTACHMENTS

This unit can use many attachments now available at your Sears store. It cannot use attachments that engage the ground like a plow, harrow, cultivator, or tiller. See page 50 for a list of available attachments.

SERIAL NUMBER _____

DATE OF PURCHASE _____

THE SERIAL NUMBER WILL BE FOUND ON THE MODEL PLATE UNDER THE SEAT.

YOU SHOULD RECORD THESE NUMBERS AND KEEP FOR FUTURE REFERENCE.

LIMITED ONE YEAR WARRANTY ON ELECTRIC START RIDING EQUIPMENT

For one year from date of purchase, when this riding equipment is maintained, lubricated, and tuned up according to the operating and maintenance instruction in the owner's manual, Sears will repair free of charge any defect in material or workmanship in this electric start riding equipment.

This warranty excludes blade(s), blade adapter(s), spark plug(s) air cleaner and belt(s), which are expendable and become worn during normal use.

This warranty does not cover:

- Tire replacement or repair caused by punctures from outside objects (such as nails, thorns, stumps, or glass); and
- repairs necessary because of operator abuse or negligence, including the failure to maintain the equipment according to instructions contained in the owner's manual; and
- riding equipment used for commercial or rental purposes.

FULL 90-DAY WARRANTY ON BATTERY

For 90 days from the date of purchase, if any battery included with this riding equipment proves defective in material or workmanship and our testing determines the battery will not hold a charge, Sears will replace the battery at no charge.

WARRANTY SERVICE IS AVAILABLE BY CONTACTING THE NEAREST SEARS SERVICE CENTER/DEPARTMENT IN THE UNITED STATES. This warranty applies only while this product is in use in the United States.

This warranty gives you specific legal rights, and you may also have other rights which may vary from state to state.

SEARS, ROEBUCK and CO., D/731CR-W, Sears Tower, Chicago, Il 60684

ASSEMBLY

1. Unpack Tractor

- Take items out of box. The box contains the items shown below.
- Cut down four corners of the carton with a utility knife and fold down sides.
- Disengage Parking Brake.
- Install Steering Wheel

- Slide upper steering shaft over lower steering shaft until bolt holes line up with slots in lower steering shaft (Fig. 1).
- Use two hex bolts 3/8 - 16 x 1-1/4 and two locknuts 3/8 - 16 to retain upper steering shaft to lower steering shaft. Tighten securely. Bolts and nuts found in bag of parts.
- Position Steering Sleeve over steering shaft assembly.
- For easier assembly, tilt tube towards front of tractor.
- Place bottom of Steering Sleeve over two front prongs on steering bushing.
- Squeeze the two steering sleeve retainers inward to allow Steering Sleeve to pass over retainers.
- Push Steering Sleeve down aligning notch on Steering Sleeve with tab on steering

bushing.







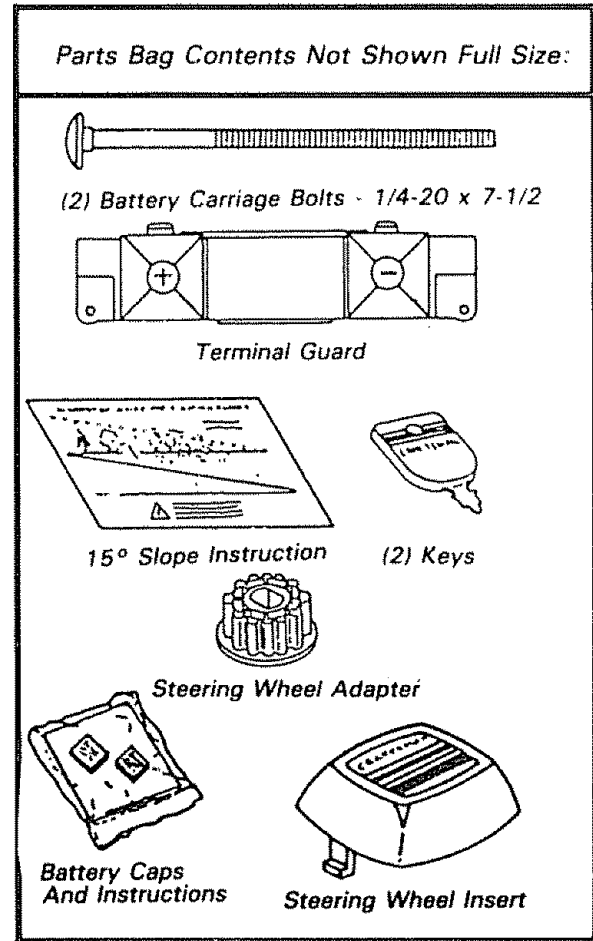
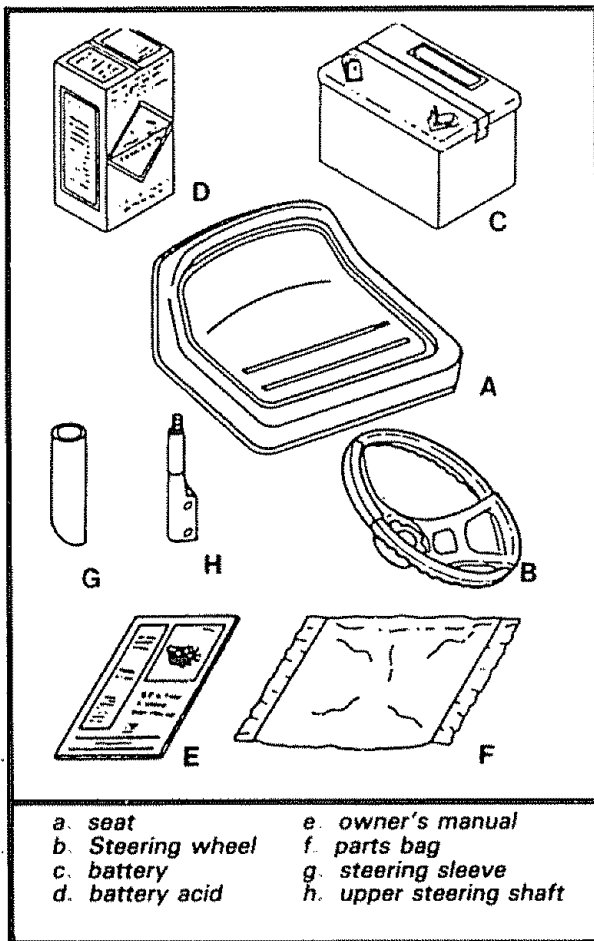

- Place steering wheel adapter on upper steering shaft.
 - With front wheels pointed straight ahead, place steering wheel on steering wheel adapter. Bars of steering wheel should point straight across tractor.
 - Place 2 - 1/4" diameter washer on upper steering shaft and install a 1/2" locknut (washer and locknut found in bag of parts). Tighten securely.
 - Snap insert into steering wheel.
- Remove plastic on tractor hood.
 - Raise attachment lift handle.
 - Roll Tractor off skid. Be careful of staples in skid



The operation of any tractor can result in foreign objects thrown into the eyes, which can result in severe eye damage. Always wear safety glasses or eye shields before starting your tractor and while moving. We recommend Wide Vision Safety Mask for over the spectacles or standard safety glasses, available at Sears Retail or Catalog Stores.

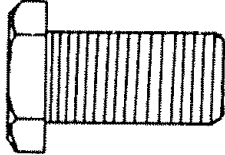
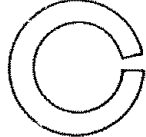
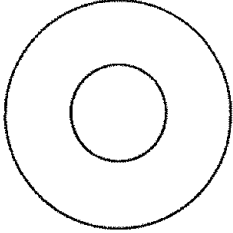
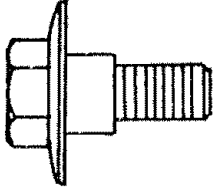

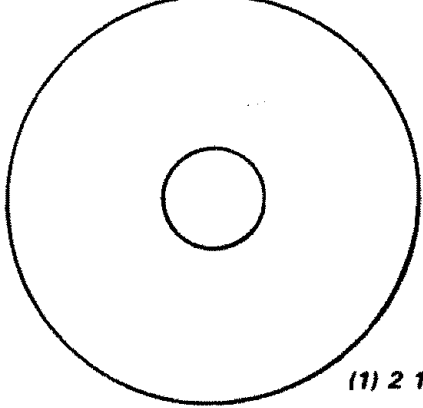
ASSEMBLY

ASSEMBLY LOCATION	PARTS BAG CONTENTS SHOWN FULL SIZE
BATTERY	 <p>(2) Wing Nut, 1/4-20</p>
BATTERY TERMINALS	 <p>(2) Hex Bolt, 1/4 - 20 x 3/4</p>  <p>(2) Lockwasher 1/4</p>  <p>(2) Washer 9/32 x 5/8 x 16 Ga.</p>  <p>(2) Hex Nut, 1/4 - 20</p>
SEAT	 <p>(1) Hex Bolt, 1/2 - 13 - x 1</p>  <p>(1) Lockwasher 1/2</p>  <p>(1) Washer 17/32 x 1 - 3/16 x 12 Ga.</p>  <p>(1) Shoulder bolt 5/16 - 18</p>
UPPER STEERING SHAFT	 <p>(2) Hex Bolt 3/8 - 16 x 1 1/4</p>  <p>(2) Hex Locknut 3/8 - 16</p>
STEERING WHEEL	 <p>(1) 2 1/4" Dia. Washer</p>  <p>(1) Locknut, 1/2-20</p>

To assemble tractor you will need:

- | | |
|---------------------|---------------------|
| (2) 7/16" Wrenches | Tire Pressure Gauge |
| (1) 1/2" Wrench | Screwdriver |
| (2) 11/16" Wrenches | Utility Knife |
| (1) 3/4" Wrench | |

NOTE: RIGHT HAND (R.H.) AND LEFT HAND (L.H.) ARE DETERMINED FROM OPERATOR'S POSITION WHILE SEATED ON THE TRACTOR.

WEAR EYE AND FACE SHIELD.

WASH HANDS OR CLOTHING IMMEDIATELY IF ACCIDENTALLY IN CONTACT WITH BATTERY ACID.

DO NOT SMOKE: FUMES FROM CHARGED BATTERY ACID ARE EXPLOSIVE.

READ THE INSTRUCTIONS INCLUDED WITH THE BATTERY VENT CAPS IN THE BAG OF PARTS. ALWAYS WEAR GLOVES, CLOTHING AND GOGGLES TO PROTECT YOUR HANDS, SKIN AND EYES.

ASSEMBLY

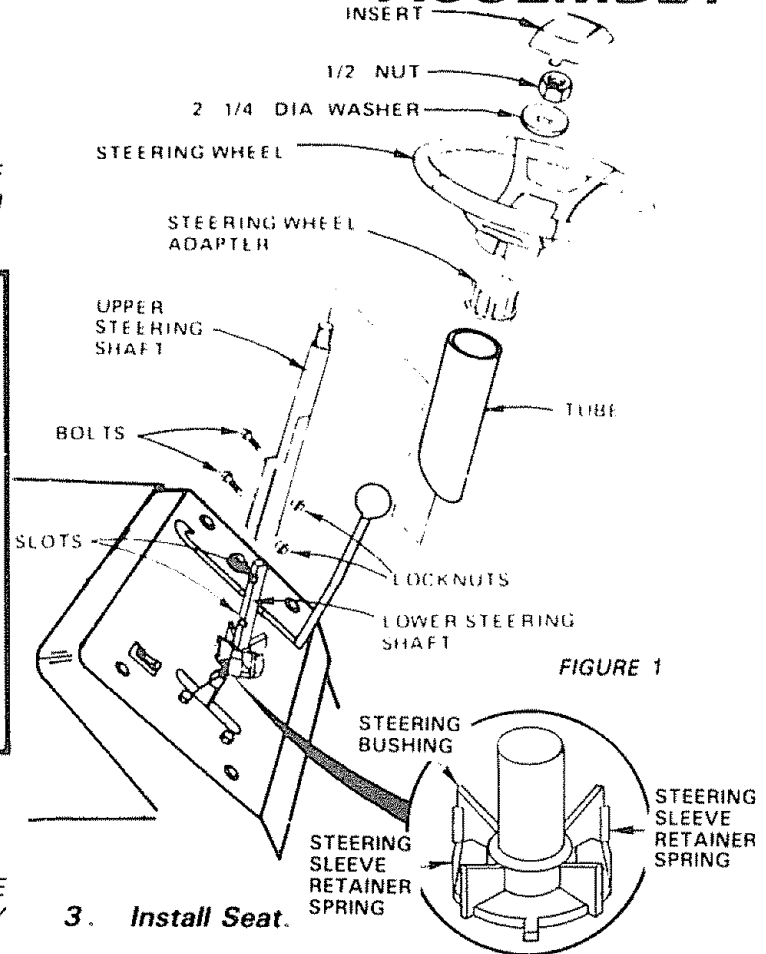

FIGURE 1

2. Prepare Battery

Fill and charge battery (before installing). NOTE: SEE DETAILED INSTRUCTIONS PACKAGED WITH BATTERY VENT CAPS FOUND IN BAG OF PARTS.

- Fill each cell with battery acid. Add the acid until it reaches the bottom of the vent tubes (Fig. 3). Do not add the acid beyond this level or the additional acid can come out when the battery is charged.
- After cells are filled, tilt battery from side to side to release air bubbles.
- Allow battery to stand and settle for at least thirty minutes. If the level of acid falls below the point described in step (a), add more acid until the correct level is reached. Install the battery caps, found in the bag of parts, to cover the vent tubes. Wash the top of the battery with water to remove any acid, then wipe dry.
- Check battery case for leakage to make sure that no damage has occurred in handling.
- Neutralize excess battery acid for disposal by adding it to four inches of water in a five gallon plastic container. Stir with a wooden or plastic paddle while adding baking soda until the addition of more soda causes no more foaming.
- It is recommended that the battery be charged before use. Use a 12 volt battery charger. Charge battery at a rate of 6 amperes for 1 hour. NOTE: OBSERVE SAFETY PRECAUTIONS, LISTED IN BOX ABOVE, REQUIRED FOR BATTERY CHARGING. Check the acid level after the battery is charged. If the acid has fallen below the correct level, add distilled or iron free water.

3. Install Seat.

Seat position should be adjusted forward or backward so that the operator can comfortably reach Clutch/Brake Pedal and safely operate tractor

- Place seat on seat pan. Screw hex head machine screw, lockwasher and flat washer into seat (Fig. 2). Screw shoulder bolt into seat (Fig. 2). Machine screw, shoulder bolt and washers found in bag of parts (shown full size on page 6).
- Tighten shoulder bolt using a 1/2" wrench. NOTE: THE SHOULDER BOLT WILL BE LOOSE IN THE SEAT PAN SLOT.
- Tighten machine screw, lockwasher and flat washer using a 1/2" wrench.
- Place seat in operating position. Sit on the seat and press clutch/brake pedal all the way down. If operating position is not comfortable, adjust seat.
- To adjust: Raise seat. Loosen machine screw. Slide seat to desired position. Tighten machine screw securely.



MACHINE SCREW-LOCKWASHER-FLAT WASHER MUST BE TIGHTENED SECURELY TO PREVENT MOVEMENT OF SEAT.

ASSEMBLY

4. Check Tires

Check the air pressure in the tires. Tires with too much air pressure will cause the unit to ride rough. The wrong air pressure will also keep the mower from cutting level. The correct air pressure is shown on the side of the tires. If the air pressure is not shown, set to pressures shown in the REPAIR AND ADJUSTMENT section (page 14).

5. Install Battery



BEFORE INSTALLING BATTERY, REMOVE METAL BRACELETS, WRISTWATCH BANDS, RINGS, ETC. FROM YOUR PERSON. TOUCHING THESE ITEMS TO BATTERY TERMINALS COULD RESULT IN BURNS.

- a. Lift seat (Fig. 2)
- b. Lower battery into fender well with battery terminals toward front of tractor (Fig. 4). Make sure battery rests in battery tray (Fig. 4)

NOTE: BE SURE BATTERY DRAIN TUBE IS SECURELY ATTACHED TO BATTERY TRAY DRAIN.



POSITIVE TERMINAL MUST BE CONNECTED FIRST TO PREVENT SPARKS FROM ACCIDENTAL GROUNDING.

- c. Connect **RED** battery cable to positive (+) battery terminal with hex bolt, flat washer, lockwasher and hex nut (shown full size on pg. 6) found in bag of parts. Tighten securely with two 7/16" wrenches. (Fig. 4)
- d. Connect **BLACK** ground cable to negative (-) battery terminal with remaining hex bolt, flat washer, lockwasher and hex nut (shown full size on pg. 6) found in bag of parts. Tighten securely. (Fig. 4)
- e. To prevent corrosion, apply grease to the battery terminals after installing cables.
- f. Using the key hole on one side of the battery support (Fig. 5) slide battery bolt into frame key hole (head of bolt down). Fasten the battery bolt to the terminal guard using wing nut, (shown full size on pg. 6) as shown in Fig. 5.
- g. Assemble the remaining battery bolt to other side of battery support and fasten terminal guard to it with remaining wing nut, (shown full size on pg. 6) as shown in Fig. 5.

NOTE: KEEP TERMINAL ACCESS DOORS CLOSED WHEN NOT IN USE.

CAUTION: DO NOT START ENGINE UNTIL YOU HAVE REVIEWED THE OPERATION SECTION OF THIS MANUAL.

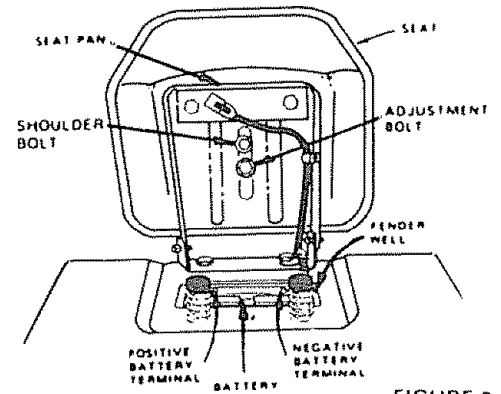

FIGURE 2

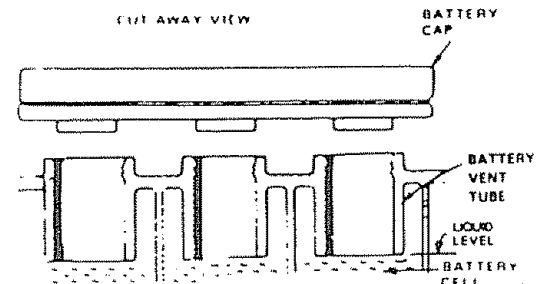

FIGURE 3

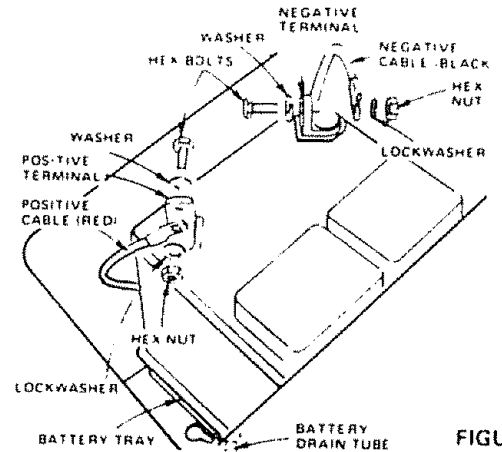

FIGURE 4

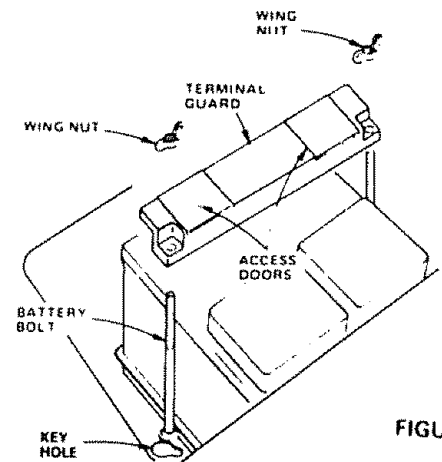
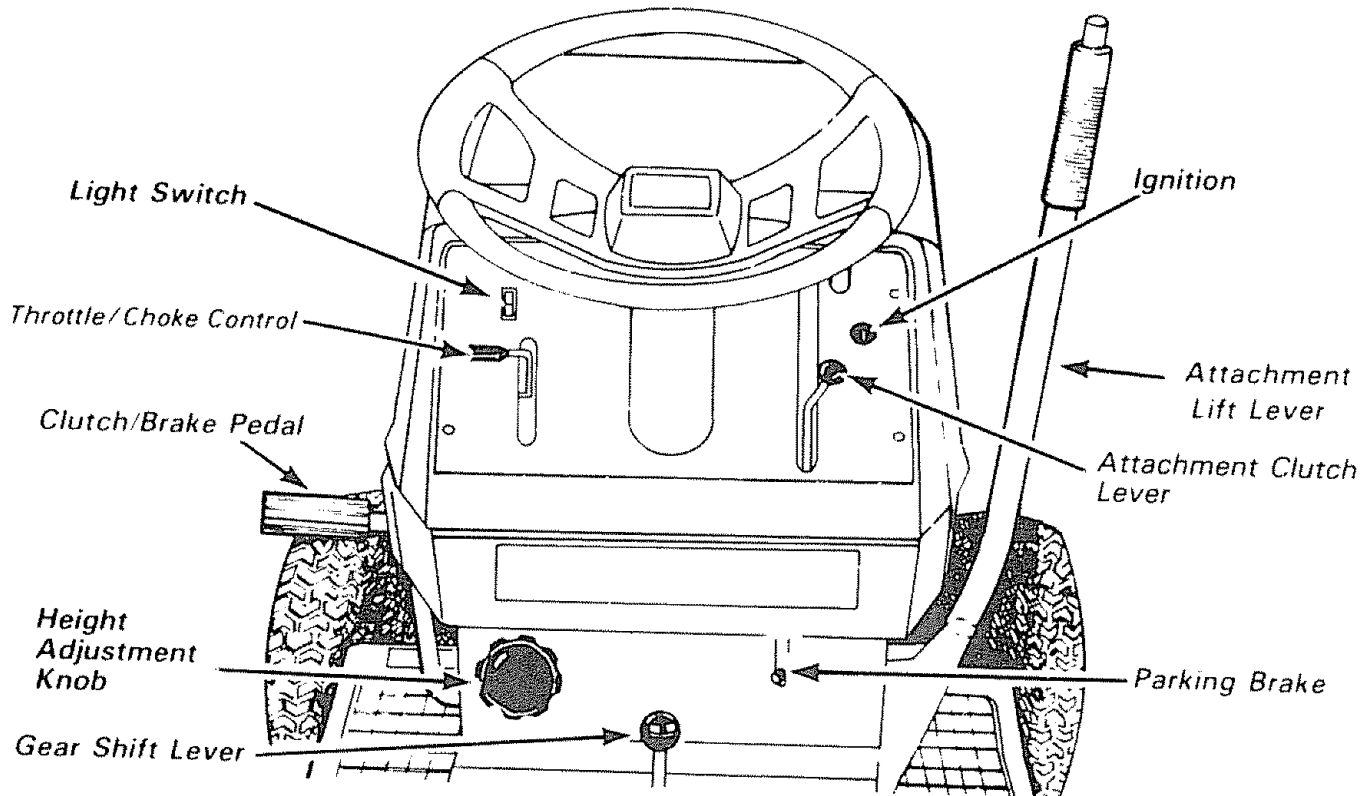

FIGURE 5

6. Maintenance After First 2 Hours (Two Mowings)

Changing oil after the first two hours (or two mowings) will help eliminate break-in residue which might be damaging to your engine.

OPERATION



ATTACHMENT CLUTCH LEVER: Push lever up to engage attachment. There will be an engine hesitation as the clutch engages.

ATTACHMENT LIFT LEVER: Use the attachment lift lever to raise and lower the attachment mounted to your tractor. Pull lever back slightly and push button, then move the lift lever forward to lower attachment.

CLUTCH/BRAKE PEDAL: The pedal has 2 functions; a clutch and a brake. To engage the brake push the pedal completely down.

ATTACHMENT HEIGHT ADJUSTMENT KNOB: Use the height adjustment knob to adjust the mower height. With the attachment lift lever in the "up" position, turn knob clockwise (↻) to raise cutting height and counterclockwise (↻) to lower cutting height.

GEARSHIFT: Press the clutch/brake pedal down firmly and move gear shift lever to desired speed.

IGNITION: Place key in ignition and turn to the right to start. The switch spring returns from the start position.

LIGHT SWITCH: Turns the headlights on and off.

PARKING BRAKE: To set the parking brake, push the clutch/brake pedal completely down. Hold the parking brake lever in "Engage" position and release pressure from pedal. Clutch/brake pedal will remain in brake position.

THROTTLE/CHOKE CONTROL: Use the throttle control to increase or decrease the speed of the engine, and to choke the engine for starting. Push lever to the right and forward to choke.

OPERATION

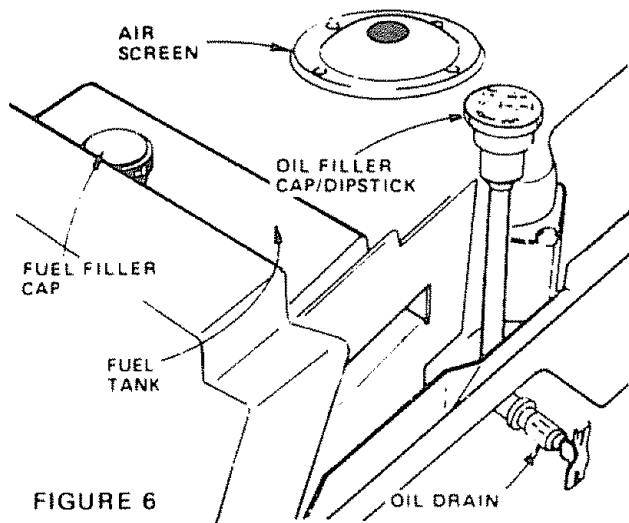

FIGURE 6

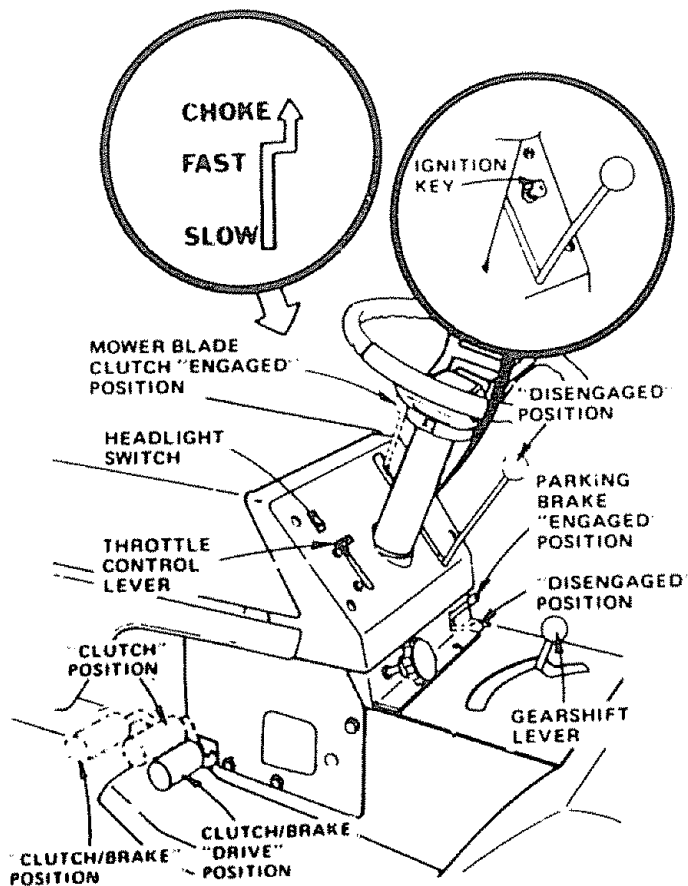

FIGURE 7

1. Stopping Your Tractor

NOTE: REMOVE KEY WHEN LEAVING TRACTOR TO PREVENT UNAUTHORIZED USE.

- Push clutch-brake pedal into full "BRAKE" position. Keep your foot on pedal. (Fig.7)
- Place attachment clutch lever in "DISENGAGED" position. (Fig.7)
- Move gear shift lever to "NEUTRAL" position. (Fig.7)
- Place parking brake in "ENGAGED" position and release pressure from clutch/brake. Pedal should remain in "BRAKE" position. (Fig.7)
- Move throttle control to "S" (slow) position. (Fig.7)
- Turn ignition key to "OFF" position. Never use choke to stop engine. (Fig.7)

2. Preparing The Engine



LEARN TO START, STOP AND REVERSE YOUR TRACTOR IN A LARGE, OPEN AREA.

- This engine has been shipped filled with summer weight oil (For cold weather operation see chart page 16). Check engine oil level. Refer to REPAIR AND ADJUSTMENT section (page 16)
- Fill fuel tank (Fig. 6). Use fresh, clean, regular unleaded gasoline. Capacity is 5 quarts



FILL TO BOTTOM OF GAS TANK FILLER NECK. DO NOT OVERFILL. WIPE OFF ANY SPILLED OIL OR FUEL. DO NOT STORE, SPILL OR USE GASOLINE NEAR AN OPEN FLAME.

CAUTION: EXPERIENCE INDICATES THAT ALCOHOL BLENDED FUELS (CALLED GASOHOL OR USING ETHANOL OR METHANOL) CAN ATTRACT MOISTURE WHICH LEADS TO SEPARATION AND FORMATION OF ACIDS DURING STORAGE. ACIDIC GAS CAN DAMAGE THE FUEL SYSTEM OF AN ENGINE WHILE IN STORAGE.

TO AVOID ENGINE PROBLEMS, THE FUEL SYSTEM SHOULD BE EMPTIED BEFORE STORAGE FOR 30 DAYS OR LONGER. DRAIN THE GAS TANK, START THE ENGINE AND LET IT RUN UNTIL THE FUEL LINES AND CARBURETOR ARE EMPTY. USE FRESH FUEL NEXT SEASON. SEE STORAGE INSTRUCTIONS FOR ADDITIONAL INFORMATION.

NEVER USE ENGINE OR CARBURETOR CLEANER PRODUCTS IN THE FUEL TANK OR PERMANENT DAMAGE MAY OCCUR.

OPERATION

3. Starting The Engine

- Move throttle control lever (Fig. 7) past "FAST" to the "CHOKE" position.
- Turn ignition key to "START" and release key as soon as engine starts.

CAUTION: DO NOT RUN STARTER CONTINUOUSLY FOR MORE THAN FIFTEEN SECONDS PER MINUTE.

- If engine does not start after four or five tries, move throttle control lever to "FAST" position, wait a few minutes and try again. If the engine does not start after four or five more tries, see the TROUBLESHOOTING Chart (page 25).
- After the engine starts move throttle control lever slowly to the "SLOW" position.
- To start a hot engine move the throttle control lever to a position between "FAST" and "SLOW"



READ THE "RULES FOR SAFE OPERATION" CAREFULLY BEFORE OPERATING YOUR MOWER

CAUTION: DO NOT ADD ADDITIONAL WEIGHT TO THE TRACTOR OTHER THAN THE OPTIONAL WHEEL WEIGHTS. EXCESSIVE WEIGHT MAY OVERLOAD AND DAMAGE THE TRANSAXLE.



ALWAYS WEAR SUBSTANTIAL FOOTWEAR AND AVOID LOOSE FITTING CLOTHING THAT COULD GET CAUGHT IN MOVING PARTS.

CAUTION TO AVOID INJURY

- Read owner's manual
- Know location and function of all controls
- Keep guards, safety shield and switches in place and working.
- Remove objects that can be thrown by blades.
- Do not mow when children and others are around.
- Never carry children or passengers.
- Always look behind machine before backing.
- Do not mow where machine can tip or slip.
- If machine stops going uphill, stop blades and back slowly down.
- Be sure blades and engine have stopped before placing hands or feet near the blades.
- Remove key when leaving machine.



MAKE SURE PARKING BRAKE WILL HOLD TRACTOR SECURE.

NEVER PLACE YOUR HANDS OR FEET IN OR UNDER ANY POWERED ATTACHMENT OR NEAR ANY MOVING PART WHILE TRACTOR OR ANY POWERED ATTACHMENT IS RUNNING.

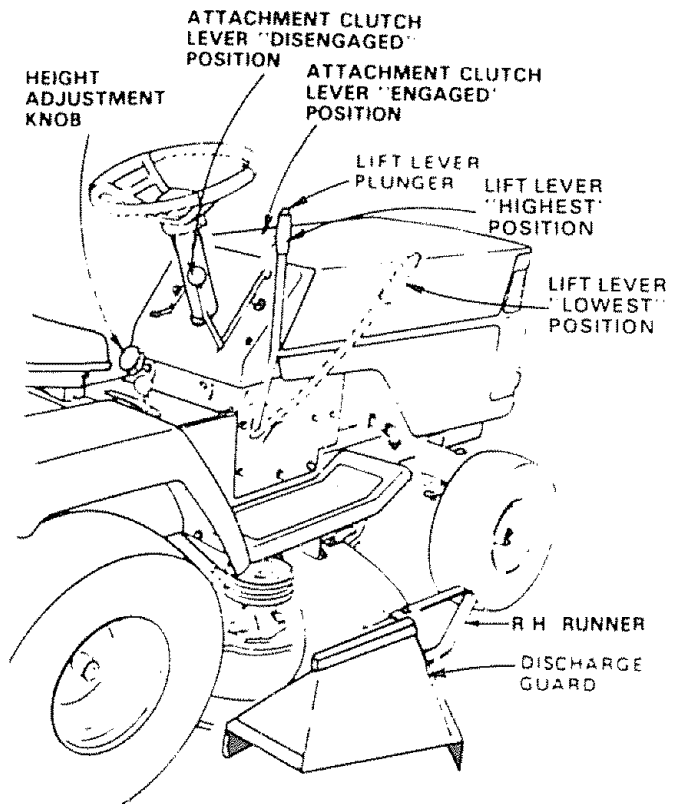

FIGURE 8

4. Operating Your Lawn Tractor & Mower



DO NOT OPERATE THE MOWER WITHOUT EITHER THE ENTIRE GRASS CATCHER, ON MOWERS SO EQUIPPED, OR THE DEFLECTOR SHIELD IN PLACE.

NOTE: THIS TRACTOR IS EQUIPPED WITH AN OPERATOR PRESENCE SENSING SWITCH. ANY ATTEMPT BY THE OPERATOR TO LEAVE THE SEAT WITH THE ENGINE RUNNING AND THE ATTACHMENT CLUTCH LEVER ENGAGED WILL SHUT OFF THE ENGINE

- Move the attachment lift lever to the high position and adjust height of cut to mid range. See Fig. 8.
- Start the engine. (See Starting the Engine)
- Move the throttle lever to mid range position. Select a low (1st or 2nd) gear until you become more familiar with the operation of the unit.
- Slowly release clutch brake pedal and proceed to the mowing area.
- Stop the unit, then select a mowing speed. (See Speed Selection Guide, page 12).
- Move throttle lever to half throttle and slowly move attachment clutch lever to engaged position, Fig. 8.

OPERATION

- g. Slowly release clutch brake pedal.
- h. Move throttle lever to fast position.
- i. Observe height of cut and readjust as desired

CAUTION: BEFORE YOU MOVE THE GEAR SHIFT LEVER, COME TO A COMPLETE STOP. FAILURE TO DO SO CAN RESULT IN GEAR BOX DAMAGE.

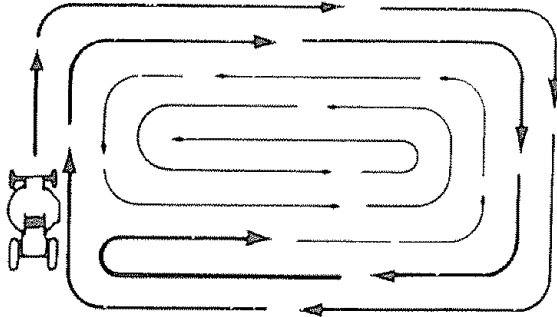

FIGURE 9

5. Mowing Tips

NOTE: TIRE CHAINS CANNOT BE USED WITH THE MOWER ATTACHED.

- a. Mower should be adjusted properly front to back and side to side for good mowing performance. Refer to REPAIR AND ADJUSTMENT section (page 22).
- b. Use the runner on the R H. side as a guide; the blade cuts approximately an inch outside the runner (Fig. 8).
- c. Drive so that clippings are discharged onto the area that has been cut. Have the cut area to the right of the machine. This will result in a more even distribution of clippings and more uniform cutting.
- d. When mowing large areas (Fig 9), start by turning to the right so that the clippings will discharge away from shrubs, fences, driveways, etc. After two or three rounds, mow in the opposite direction making left hand turns until finished.
- e. If grass is extremely tall, it should be mowed twice. The first time cut relatively high; the second time to the desired height.
- f. The left hand side of mower should be used for trimming.
- g. See Speed Selection Chart.
- h. Do not mow tall, dry (brown) grass over 6 inches tall. It is a fire hazard.

6. Operating The Tractor On Hills



DO NOT DRIVE UP OR DOWN HILLS WITH SLOPES GREATER THAN 15° AND DO NOT DRIVE ACROSS ANY SLOPE. REFER TO PAGE 51.

- a. Move gear shift lever to "1st" gear before starting up or down hills.
- b. **AVOID STOPPING OR SHIFTING ON HILLS**
- c. If slowing is necessary, move throttle control lever to slower position.



LEAVE ENOUGH ROOM WHEN STOPPING AND STARTING TO ALLOW SLIGHT TRACTOR ROLL DOWNHILL AS CLUTCH-BRAKE PEDAL MOVES THROUGH CLUTCH POSITION.

- d. If stopping is absolutely necessary, push clutch/brake pedal quickly to brake position.
- e. To restart tractor movement, make sure tractor is in the lowest speed range ("1st" Gear) and release clutch-brake pedal **SLOWLY**.
- f. Make all turns gradually.

7. Transporting Your Tractor

For pushing or towing your tractor, place Gear Shift Lever in "N" position. Do not tow or push at more than 6 MPH.

SPEED SELECTION GUIDE		
FUNCTION	GEARSHIFT	THROTTLE
Normal Mowing	2 or 3	
Heavy Mowing	1 or 2	
Snow Blowing	1	
Snow Blade	2	FAST
Transport	4	SLOW-FAST

MAINTENANCE

To keep your tractor running better, longer, perform necessary service using the following maintenance schedule:

With Every Mowing

1. Make sure all nuts on bolts are tight and cotter pins and retainer springs are secure.
2. Observe all safety precautions.
3. Keep tractor well lubricated (refer to page 17)



BEFORE MAKING ANY INSPECTION, ADJUSTMENT, OR REPAIR:

1. PUSH CLUTCH/BRAKE PEDAL COMPLETELY DOWN.
2. MOVE GEAR SHIFT CONTROL LEVER TO NEUTRAL POSITION.
3. PLACE PARKING BRAKE IN "ENGAGED" POSITION. REMOVE FOOT FROM PEDAL.
4. DISENGAGE ATTACHMENT CLUTCH LEVER.
5. SHUT OFF THE ENGINE.
6. MAKE ABSOLUTELY SURE THE BLADES AND ALL MOVING PARTS HAVE COMPLETELY STOPPED.
7. DISCONNECT THE SPARK PLUG WIRE FROM THE SPARK PLUG AND KEEP WIRE AWAY FROM THE SPARK PLUG TO PREVENT INJURY FROM ACCIDENTAL STARTING. BE CAREFUL TO AVOID TOUCHING HOT ENGINE OR MUFFLER COMPONENTS.

SERVICE RECORD

(Enter Date Maintenance Performed)

SERVICE RECORD	SCHEDULE							
	FIRST 2 HOURS	EVERY 5 HOURS	EVERY 25 HOURS	EVERY 50 HOURS	EVERY 100 HOURS			
Fill in dates as you complete regular service								
Blades - sharpen			✓					
Brake Adjustment			✓					
Check Battery				✓				
Change Engine Oil	✓			✓				
Check Engine Oil Level		✓						
Clean Air Cleaner Element				✓				
Check Muffler				✓				
Clean Air Screen				✓				
Clean Front Grill				✓				
Lubricate Tractor				✓				
Replace Spark Plug					✓			
Replace Air Cleaner Element					✓			
Check Tire Pressure			✓					
Replace Fuel Filter					✓			

REPAIR AND ADJUSTMENT

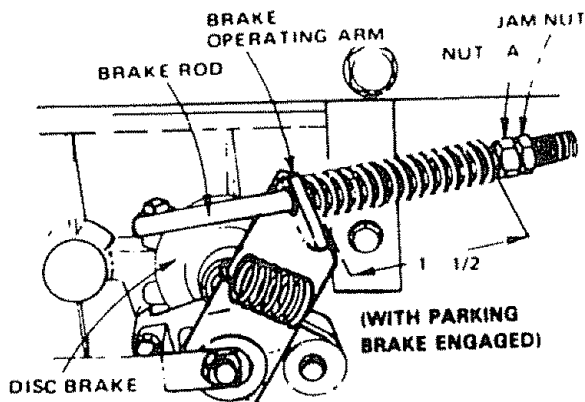

FIGURE 10

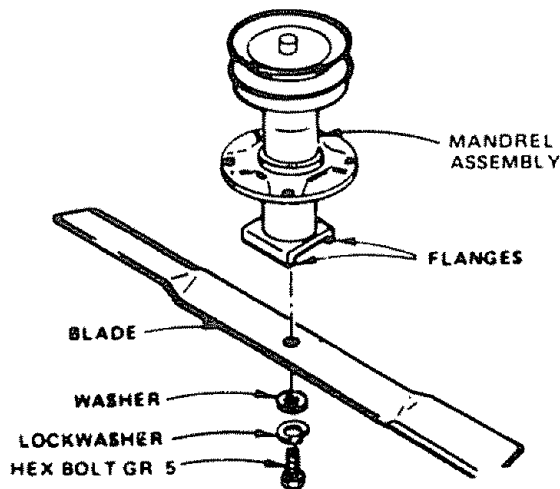
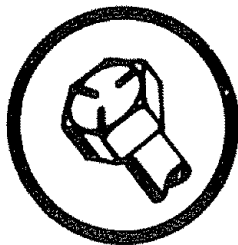

FIGURE 11



A GRADE 5 HEAT TREATED BOLT CAN BE IDENTIFIED BY THREE LINES ON THE BOLT HEAD AS SHOWN AT LEFT.

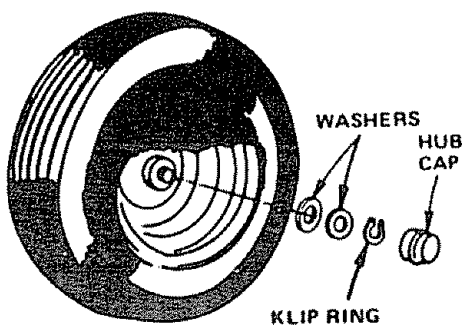

FIGURE 12

1. Brake Adjustment

This tractor is equipped with an adjustable brake system mounted on the right side of the transaxle (Fig. 10).



IF TRACTOR REQUIRES MORE THAN SIX FEET STOPPING DISTANCE IN HIGHEST GEAR, THEN BRAKE MUST BE ADJUSTED.

- Depress clutch/brake pedal and engage parking brake.
- Measure distance between brake operating arm and nut "A" on brake rod.
- If distance is other than 1-1/2" loosen jam nut (Fig. 10) and turn nut "A" until distance becomes 1-1/2", retighten jam nut against nut "A".

Road test tractor for proper stopping distance as stated above. Readjust if necessary.

2. Tire Care

- Maintain tire pressure in front at 14 PSI and rear tires at 10 PSI.
- Keep tires free of gasoline, oil, or insect control chemicals which can harm rubber.
- Avoid stumps, stones, deep ruts and other hazards that may cause tire damage.
- Removing wheel for tire repair (Fig. 12).
 - Block up axle securely.
 - Remove hub cap, klip ring and washer to allow wheel removal.
 - Repair tire and reassemble. Replace washers and snap klip ring securely in axle groove. Replace hub cap.

3. Blade Care

For best results mower blades must be kept sharp. The blades can be sharpened with a few strokes of a file, or on a grinding wheel. We suggest they be sharpened after every 25 hours of mowing. Do not attempt to sharpen while on mower. If you mow in sandy soil check the blades after each two mowings. The sand wears the blade away rapidly.

a. Blade Replacement

Raise mower to highest position to permit access to blades.

- Remove the hex head bolt, lockwasher and flat washer (Fig. 11) (turn counterclockwise) (↺).
- Remove and discard old blade.
- Clean top and bottom of mower housing.
- Install new blade with SHARP EDGE DOWN and secure with flat washer, lockwasher and hex head bolt. **TIGHTEN SECURELY.**



ALWAYS USE GRADE 5 HEAT TREATED BOLTS TO ATTACH BLADES. DO NOT USE PLATED BOLTS. CHECK BOLTS IN BLADES OCCASIONALLY TO MAKE SURE BOLTS ARE TIGHT. TORQUE BOLTS TO 30-35 FT.-LBS.

REPAIR AND ADJUSTMENT

- b. When grinding, care should be taken to maintain blade balance and the blade should be checked for proper balance before reinstallation on mower. An unbalanced or bent blade will cause excessive vibration when running, and eventual damage to mower or engine. Replace bent or damaged blades.
- c. To check blade balance, drive a nail into a beam or wall. Leave about one inch of the straight nail exposed. Place center hole of clean blade over the head of the nail (Fig. 13). NOTE: CENTER HOLE OF BLADE ON NAIL, IF BLADE IS PROPERLY BALANCED, BLADE SHOULD REMAIN IN POSITION SHOWN IN FIG. 13. IF EITHER END OF THE BLADE MOVES DOWNWARD, BLADE IS NOT BALANCED. SHARPEN THE HEAVY END UNTIL BLADE IS BALANCED.

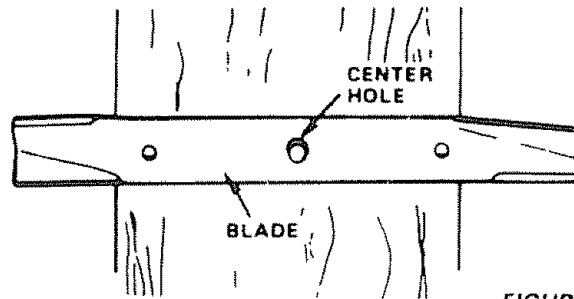

FIGURE 13

4. BATTERY CARE

Check Battery

- a. Battery acid solution level in each battery cell should be even with bottoms of vent tubes in cells (Fig. 14). Add ONLY distilled or iron free water if necessary. NOTE: DO NOT OVERFILL.
- b. Keep battery and terminals clean.
- c. Keep battery bolts tight.
- d. Keep vent caps tight and small vent holes in caps open.
- e. Recharge at 6 amperes for 1 hour if necessary.

Clean Battery and Terminals

Corrosion and dirt on the battery and terminals cause the battery to "leak" power and hinders the operation of the charger.

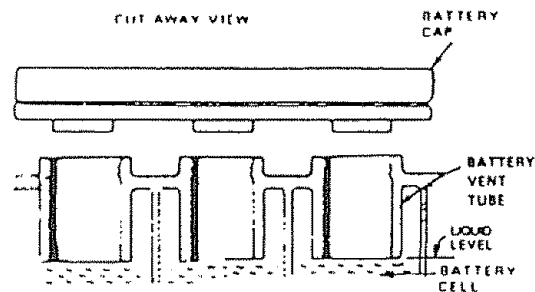

FIGURE 14

LEAD-ACID BATTERIES GENERATE EXPLOSIVE GASES. KEEP SPARKS, FLAME AND SMOKING MATERIALS AWAY FROM BATTERIES. ALWAYS SHIELD YOUR EYES AROUND BATTERIES.

- a. Remove terminal guard.
- b. Disconnect BLACK battery cable, then RED battery cable, and remove battery from tractor.
- c. Wash battery with four tablespoons of baking soda to one gallon of water. NOTE: BE CAREFUL NOT TO GET THE SODA SOLUTION INTO THE CELLS.
- d. Rinse the battery with plain water, dry and reinstall on tractor.
- e. Clean terminals and battery cable ends with wire brush until bright.
- f. Replace battery cables, connecting RED battery cable to positive terminal first, then BLACK battery cable to negative terminal. Coat terminal connections with grease after installation of cables.
- g. Replace terminal guard.

REPAIR AND ADJUSTMENT

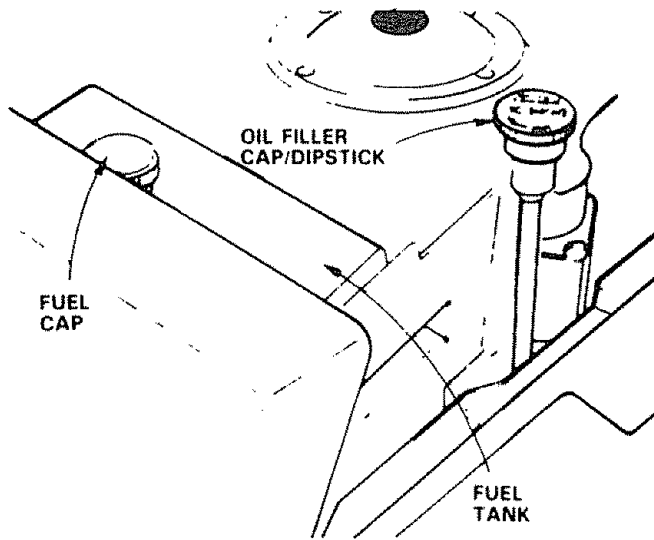

FIGURE 15

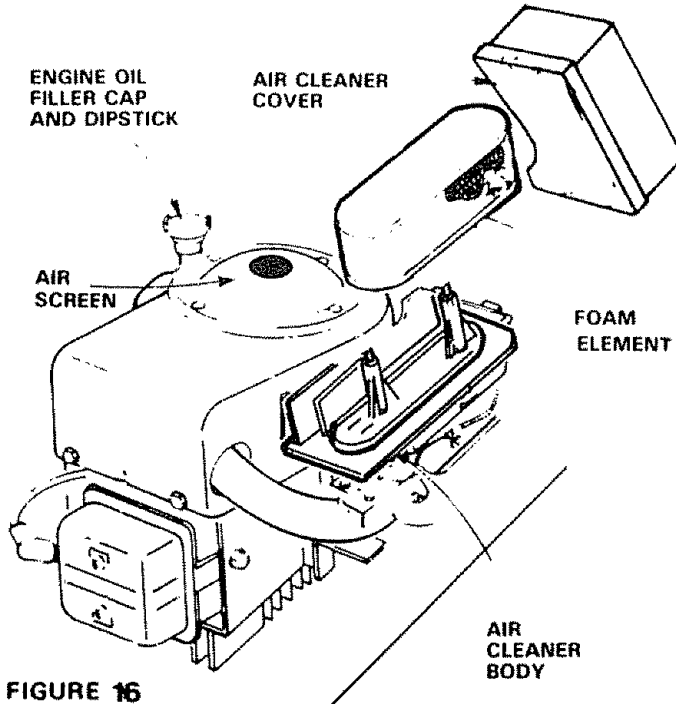

FIGURE 16

5. Change Engine Oil

The best time to change engine oil is at the end of a day's operation when all dirt and foreign materials are suspended in the hot oil.

Capacity is 1 quart. **NOTE: DO NOT OVER FILL.** Dipstick assembly must be securely tightened into tube at all times when engine is operating.

CAUTION: TO AVOID DAMAGE TO THE STARTING SYSTEM, USE SAE 5W30 OIL WHEN THE TEMPERATURE FALLS BELOW 32°.

Recommended SAE Viscosity Grades

Determine temperature range expected before next oil change. All oil must meet A.P.I. service classification SD, SE or SF.

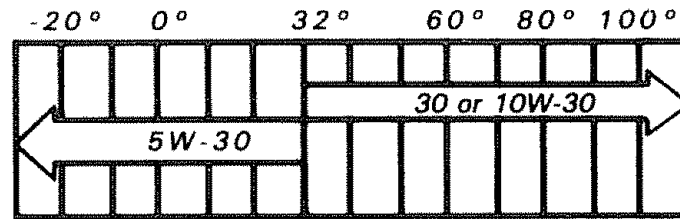

6. Check Engine Oil Level

NOTE: DO NOT CHECK ENGINE OIL LEVEL WITH ENGINE RUNNING.

Several minutes after stopping engine, check engine oil level with tractor on level ground. Wipe dipstick (Fig. 15) clean, screw it down tight for a few seconds, remove and read oil level. If necessary, add oil until "FULL" mark is reached. (See chart above). **NOTE: DO NOT OVERFILL.**

7. Clean Air Cleaner Element (Fig. 16)

- Remove two cover knobs and remove air cleaner cover.
- Remove foam pre-cleaner.
 - Wash pre-cleaner in liquid detergent and warm water to remove dirt.
 - Wrap pre-cleaner in cloth and squeeze dry.
 - Wipe foam with a light coat of engine oil. Do not saturate, squeeze in rag or towel to remove excess oil.
- Remove two nuts from top of cartridge.
- Remove cartridge and clean air cleaner body carefully to prevent dirt from entering carburetor.
- Clean cartridge by gently tapping on flat surface. If very dirty, replace cartridge.
- Reassemble air cleaner.

NOTE: Nuts holding air cleaner cartridge must be installed with fiber washers down on cartridge plate to prevent dirt from entering carburetor. Tighten nuts by hand. Over tightening could collapse cartridge.

NOTE: NEVER RUN ENGINE WITH AIR CLEANER REMOVED.

8. Clean Air Screen and Engine Cooling Fins.



ALWAYS WEAR EYE AND FACE PROTECTION WHEN USING COMPRESSED AIR.

Air screen and cooling fins (Figs. 16 and 17) must be kept free of dirt and chaff to prevent engine damage from overheating. Clean with a wire brush or compressed air to remove dirt and dried gum fibers.

- Remove hood (page 20).
- Snap off air cleaner cover (Fig. 16).
- Remove 3 screws securing air cleaner body (Figs. 16 and 17) and remove. (Cover carburetor to prevent entry of dirt.)
- Remove oil dipstick and cover opening to prevent entry of dirt.
- Remove 3 screws from blower housing and lift housing off engine (Fig. 17).
- Use compressed air or stiff bristle brush to thoroughly clean engine cooling fins (Fig. 17) and air screen (Fig. 16).
- To reassemble, reverse above procedure.
- Be certain carburetor tube, breather tube, and gaskets are in place (Fig. 17).

REPAIR AND ADJUSTMENT

9. Check Muffler

Inspect and replace damaged muffler and/or deflector as it could create a fire hazard and/or damage.



DO NOT TOUCH HOT MUFFLER, CYLINDER OR FINS AS CONTACT MAY CAUSE BURNS.

10. Lubricate Pivot Points

Place several drops of SAE 30 oil at points where parts move against each other, especially:

- Front axle pivot
- Hood hinges
- Foot pedal shaft (both ends)
- Lift shaft (both ends)

See Lubrication Chart page 24.

11. Starting your Tractor With a Weak Battery

If your battery is too weak to start the engine, it should be recharged. If "jumper cables" are used for emergency starting, follow this procedure:

NOTE: YOUR TRACTOR IS EQUIPPED WITH A 12 VOLT NEGATIVE GROUND SYSTEM. THE OTHER VEHICLE MUST ALSO BE A 12 VOLT NEGATIVE GROUND SYSTEM.



LEAD-ACID BATTERIES GENERATE EXPLOSIVE GASES. KEEP SPARKS, FLAME AND SMOKING MATERIALS AWAY FROM BATTERIES. ALWAYS WEAR EYE PROTECTION WHEN AROUND BATTERIES.

- Connect each end of the RED cable to the POSITIVE (+) terminals of each battery (taking care not to short against chassis). (Fig. 18)
- Connect one end of the BLACK cable to the NEGATIVE (-) terminal of fully charged battery.
- Connect the other end of the cable to the L.H. side panel bolt (Fig. 19) **NOTE: KEEP AWAY FROM GAS TANK AND BATTERY.**
- Disconnect cables in reverse order:
 - L.H. side Panel Bolt (Fig. 19)
 - Negative terminal of fully charged battery
 - Positive terminals



DO NOT USE YOUR TRACTOR BATTERY TO START OTHER VEHICLES.

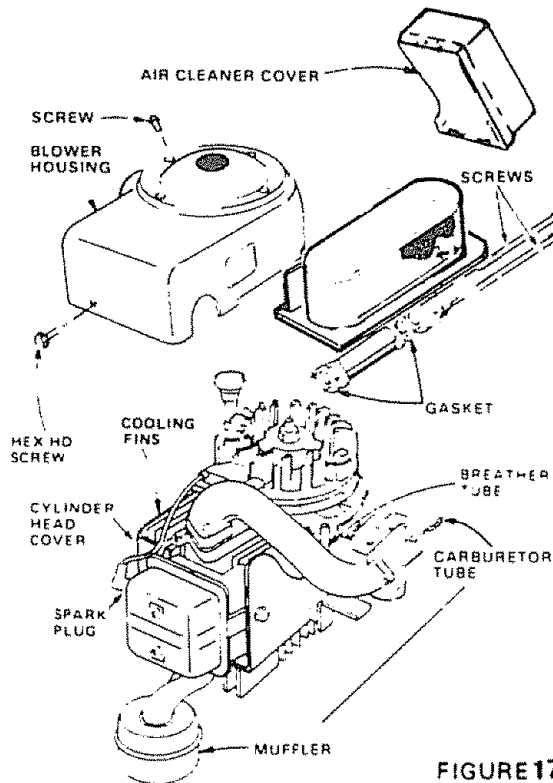

FIGURE 17

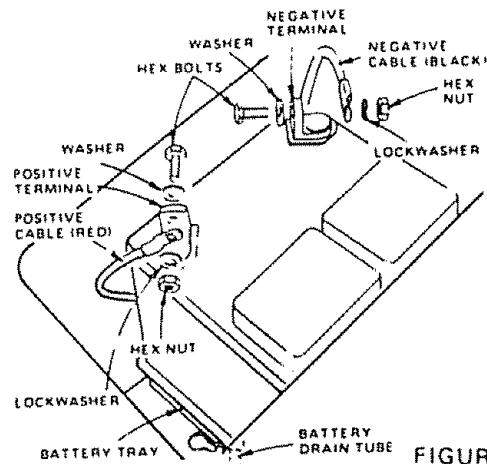

FIGURE 18

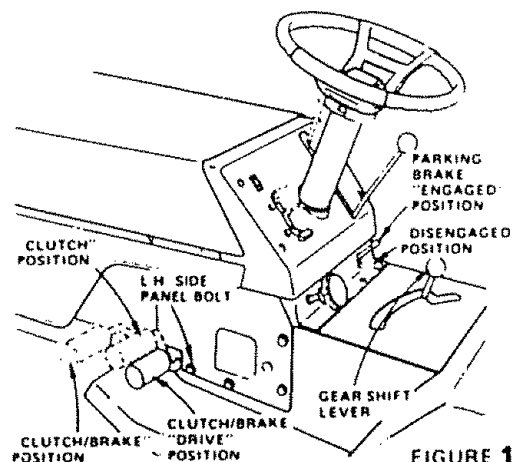

FIGURE 19

REPAIR AND ADJUSTMENT

- d. If holes do not align, repeat steps in throttle cable adjustment.

13. Carburetor adjustment

NOTE: ADJUST THROTTLE CONTROL CABLE BEFORE MAKING ANY ADJUSTMENT TO CARBURETOR.

- a. With engine off turn high speed mixture screw clockwise (↻) closing finger tight ONLY, and turn counterclockwise (↺) 1-¾ turns (Fig. 20).

NOTE: THE SCREW SEAT MAY BE DAMAGED BY TURNING IT TOO FAR CLOCKWISE.

- b. Turn idle mixture screw clockwise (↻) closing finger tight only, and turn counterclockwise (↺) 1-½ turns (Fig. 20).

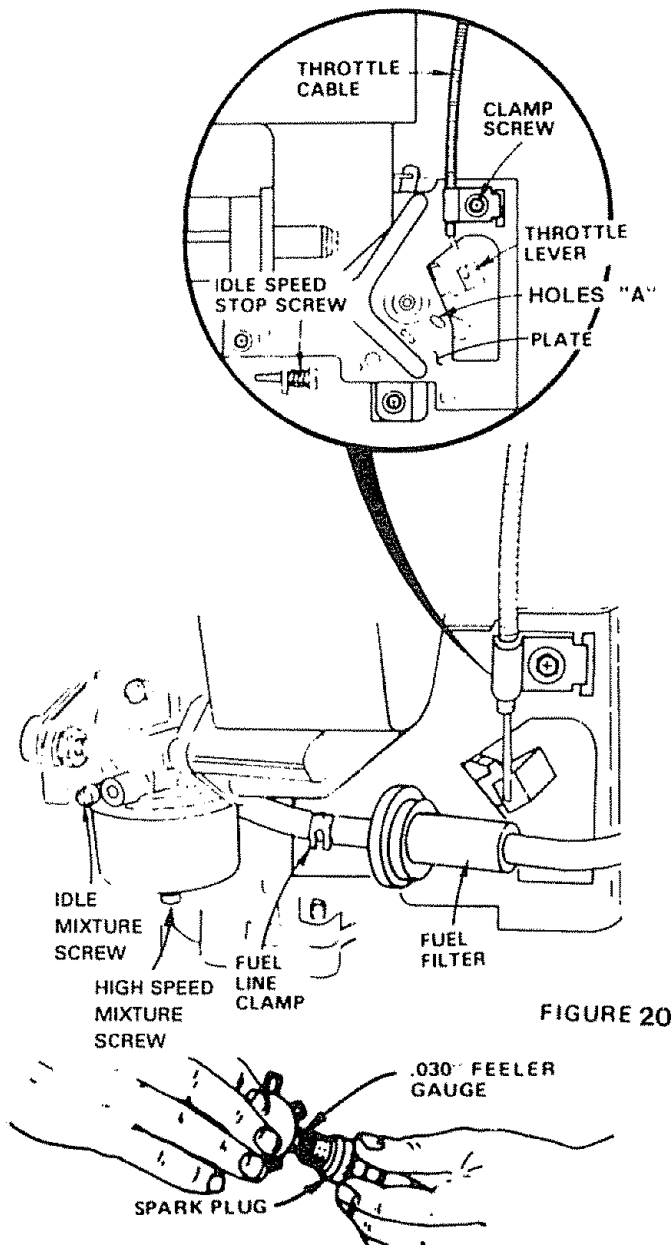

FIGURE 20

FIGURE 21

12. Throttle Control Cable Adjustment

DO NOT MAKE UNNECESSARY ADJUSTMENTS. FACTORY SETTINGS ARE SATISFACTORY FOR MOST APPLICATIONS AND CONDITIONS. IF ADJUSTMENTS ARE NEEDED, PROCEED AS FOLLOWS.

- Make sure air cleaner is clean (see page 16).
- With engine not running, place throttle control in "FAST" detent (not in "CHOKE" position).
- Check that hole in throttle lever and hole in plate line up (Fig. 20 - Insert). If holes "A" are not aligned, loosen clamp screw and move throttle cable until holes are aligned. Tighten clamp screw.

REFER TO "STARTING THE ENGINE" PAGE 11.

- Start engine and allow to warm for five minutes. Make final adjustment with engine running and Gear Shift lever in "NEUTRAL" position.
- With throttle control lever in "FAST" position, turn high speed mixture screw clockwise (↻) until engine runs "rough" then turn counterclockwise (↺) ¾ turn.
- With throttle control lever in "SLOW" position, turn idle mixture screw counterclockwise (↺) until engine runs "rough" and then turn clockwise (↻) until engine begins to die. Turn idle mixture screw to a point midway between these positions.
- With throttle control lever in "SLOW" position, engine should idle at 1700 RPM. If engine idles too slow, push throttle control lever above idle and turn idle speed screw one turn clockwise (↻). Set throttle control lever at "SLOW". Repeat until satisfactory idle is attained.
- If engine idles too fast with throttle control lever in "SLOW" position push throttle control lever above idle and turn idle speed screw one turn counterclockwise (↺). Set throttle control lever at "SLOW". Repeat until satisfactory idle is attained.
- High speed stop is factory adjusted. DO NOT ADJUST - DAMAGE MAY RESULT.

14. Replace Spark Plug

Replace spark plug at the beginning of each mowing season or every 100 hours, whichever comes first. Gap should be set at 0.030 inch (Fig.21).

15. Adjust Valves on Engine

After approximately 200 hours of operation, the engine valves will require adjustment. It is suggested that a Sears Service Center do this work. Correct settings are: Intake - .002, Exhaust - .004.

REPAIR AND ADJUSTMENT



BE SURE THERE ARE NO FUEL LINE LEAKS AND THAT HOSE CLAMPS ARE PROPERLY INSTALLED.

16. Replace In-Line Fuel Filter

If fuel filter is clogged, obstructing fuel flow to carburetor, replacement is required.

- With engine cool, remove filter and plug fuel line sections which were removed from both ends of fuel filter (Fig. 20).
- Place new fuel filter in position in fuel line.

17. Motion Drive Belt Removal

The tractor drive belt may be replaced without tools. Park the tractor on level area. Engage parking brake. NOTE: A BELT INSTALLATION DECAL IS UNDER LEFT FOOTREST

- Remove mower. (See page 20).
 - Remove two retainer springs from belt guide bracket below transaxle pulley. Remove bracket (Fig. 22).
 - Swing belt guides away from belt, toward rear of tractor (Fig. 22).
 - Roll belt over top of transaxle pulley.
 - Roll belt over engine pulley and off idler (Fig. 23).
 - Release parking brake. Pull belt as far as possible over top of clutch pulley.
 - Reset parking brake. Pull belt over top of clutch pulley (Fig. 23).
 - Pull belt out through shift gate to remove from tractor (Fig. 24).
- Install belt by reversing above procedure.

NOTE: REPLACE ONLY WITH BELT LISTED IN MANUAL

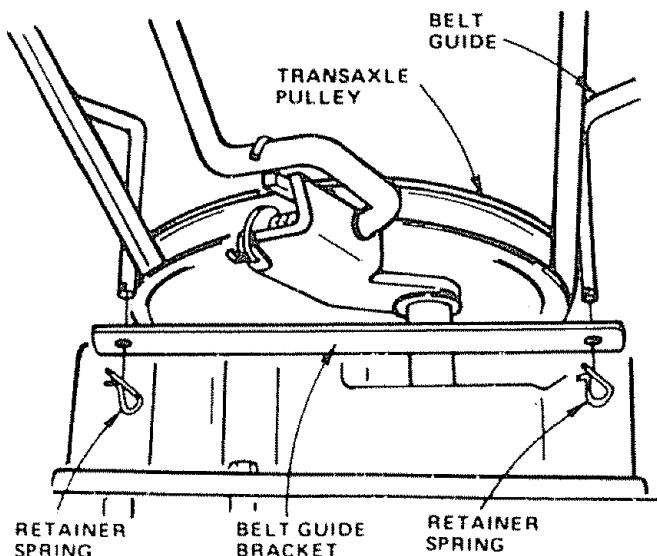
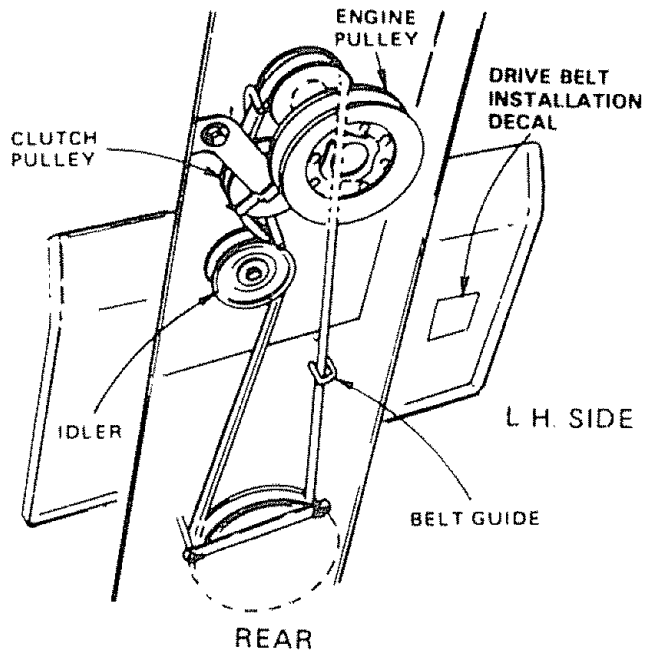

FIGURE 22



VIEWED FROM BOTTOM OF TRACTOR

FIGURE 23

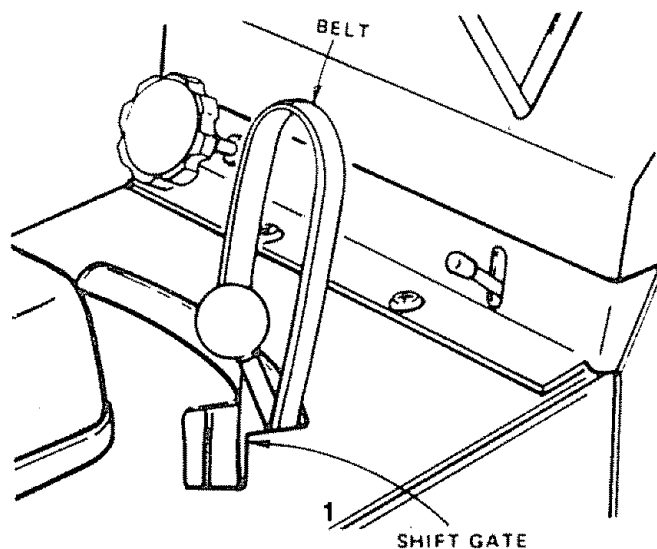

FIGURE 24

REPAIR AND ADJUSTMENT

18. Fuse Replacement

Replace with 30 amp automotive - type plug-in fuse. The fuse holder is located under the dash.

19. Hood Removal

- To raise hood, lift at rear of hood.
- To remove hood, grill and side panels, raise hood and loosen one screw on each side panel. (This screw remains in the side panel) (Fig. 25).
- Unsnap headlight connection (Fig. 26).
- Stand in front of tractor. Grasp hood and tilt forward and lift off (Fig. 26).
- To reinstall, reverse above procedure.

20. Mower Removal

- Remove mower belt per instructions under "Mower Drive Belt Removal" through step(c).
- Remove retainer spring from clutch rod; pull clutch rod out of clutch bracket. (Fig. 27)
- Pull retainer springs out of rear suspension trunnions. Remove rear suspension trunnions from lift brackets (Fig. 27).
- Pull retainer spring out of rear hinge pin. Remove rear hinge pin. (Fig. 27)
- Pull retainer spring out of front hinge pin. Remove front hinge pin (Fig. 27).
- Use lift lever to raise suspension arms. Slide mower out from under tractor.

NOTE: IF AN ATTACHMENT OTHER THAN THE MOWER DECK IS TO BE MOUNTED ON THE TRACTOR, THE L.H. AND R.H. SUSPENSION ARMS (FIG. 27) SHOULD BE REMOVED FROM TRACTOR.

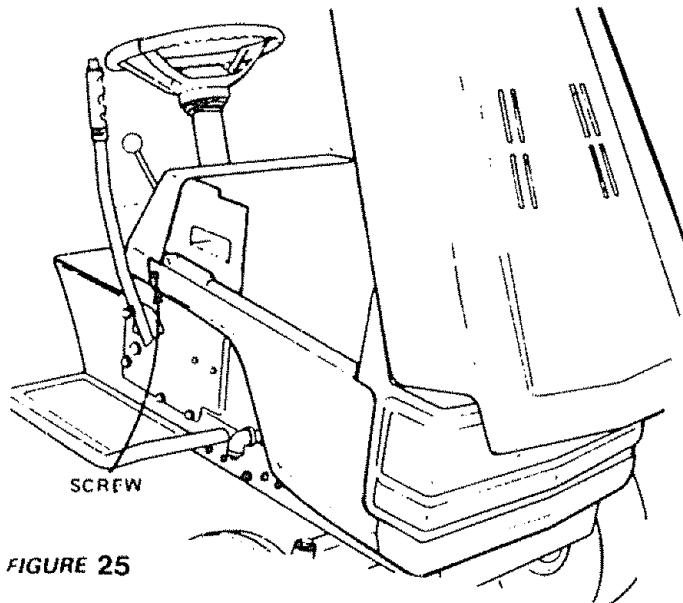

FIGURE 25

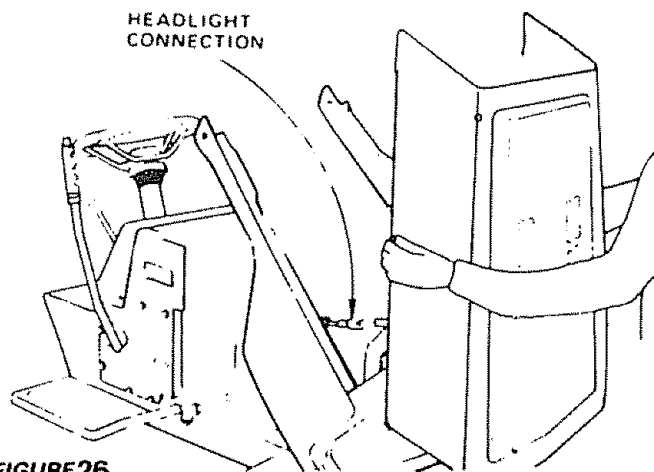

FIGURE 26

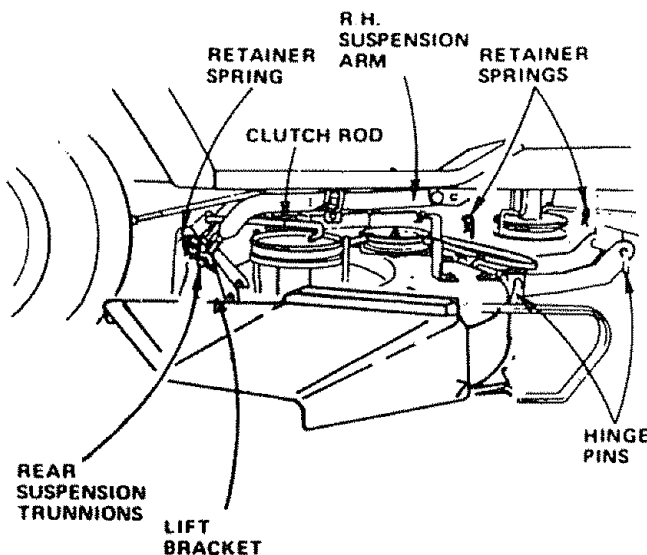

FIGURE 27

REPAIR AND ADJUSTMENT

21. Mower Installation

Your Mower installs without the use of tools. Raise Attachment Lift Lever (Fig. 28) to its highest position. Turn height adjustment knob to lowest position (Fig. 29).

- Slide Mower under tractor, discharge guard to R.H. Side.
- Install front hinge pin through axle and parallel link (Fig. 30). Secure with retainer spring.
- Install rear hinge pin through mower lift brackets and parallel link (Fig. 30). Secure with retainer spring.
- Install clutch rod in clutch lever (Fig. 30).
- Move Attachment lift lever (Fig. 28) forward to lower suspension arms. Slide trunnions through lift bracket holes and secure with retainer springs (Fig. 27).
- Roll belt over engine pulley. Make sure belt is inside belt guides (Fig. 29). See belt drive schematic decal on mower housing.
- Use Attachment lift lever (Fig. 28) to raise mower.
- Turn height adjustment knob clockwise (↻) to the middle of its travel, or to desired cut height (Fig. 29).

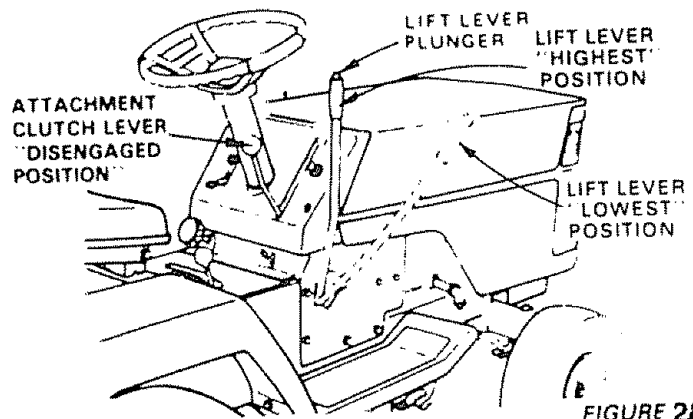

FIGURE 28

22. Mower Drive Belt Removal

NOTE: MOWER BELT INSTALLATION DECAL LOCATED ON MOWER HOUSING.

REPLACE ONLY WITH THE BELTS SPECIFIED IN THIS MANUAL.

- Place attachment clutch lever in "Disengaged" position (Fig. 28)
- Turn height adjustment knob to lowest position. Move Attachment lift lever (Fig. 28) forward to lower mower to its lowest position.
- Roll belt off engine pulley (Fig. 29).
- Pull belt off both mower deck pulleys.
- Spring belt guide away from idler pulley and pull belt off idler pulley.
- Slide belt from under extension spring.

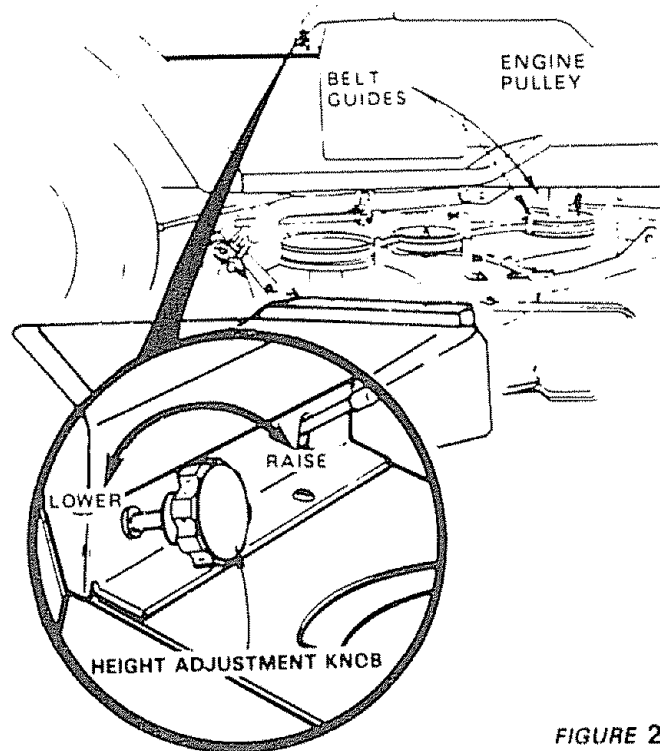

FIGURE 29

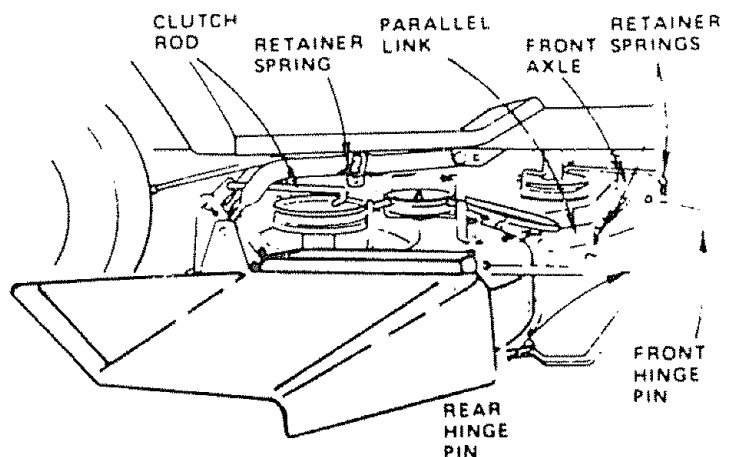

FIGURE 30

REPAIR AND ADJUSTMENT

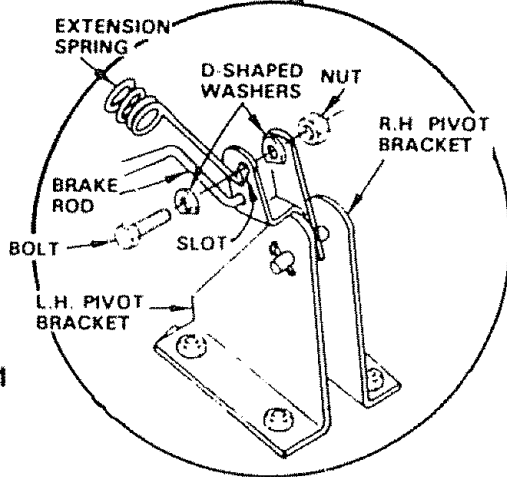
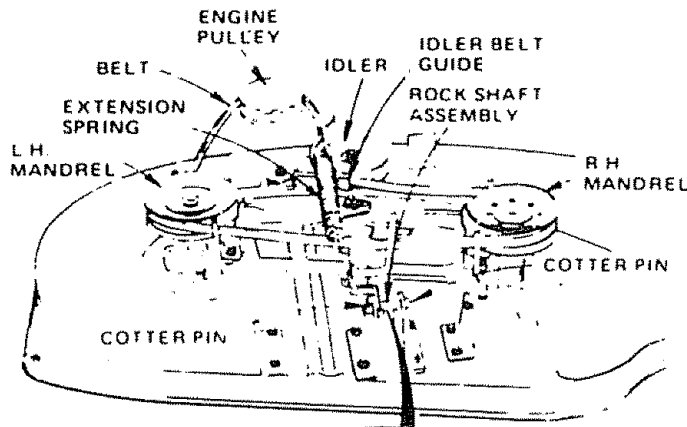

FIGURE 31

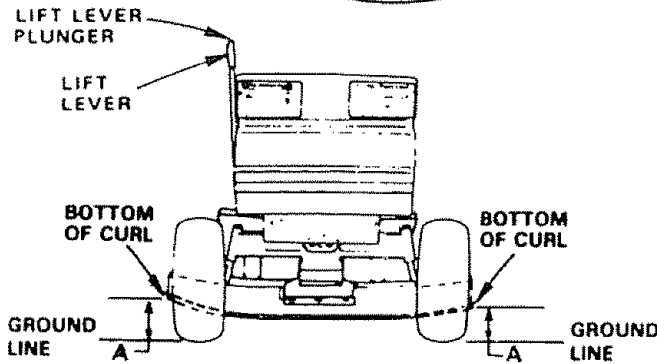

FIGURE 32

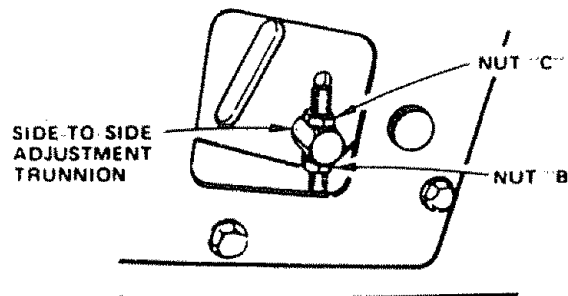

FIGURE 33

23. Mower Drive Belt Replacement

- Slide belt under extension spring (Fig. 31).
- Place belt on rear side of both mandrel pulleys.
- Spring idler belt guide down and place belt around rear side of idler pulley.
- Roll belt over engine pulley.
- Make sure belt is inside all belt guides.

24. Mower Drive Belt Adjustment

Your tractor has been manufactured with the ability to readjust the mower belt drive to provide you with longer belt life.

If the attachment clutch lever travels 3-1/2" up the slot in the dash before spring resistance is evident, adjustment is necessary. NOTE: CHECK FOR PROPER SPRING TENSION WITH THE ENGINE OFF AND THE LIFT LEVER IN THE HIGHEST POSITION.

- Lower the mower deck for easier access
- Using (2) 7/16" wrenches, remove the bolt, nut & D-shaped washers (Fig. 31 - Inset).
- Move extension spring from lower end of slot to upper end in rock shaft assembly and install bolt, nut & the D-shaped washers.
- Tighten bolt and nut to secure the D-shaped washers (flat side down).

NOTE: WHEN INSTALLING A NEW BELT, EXTENSION SPRING MUST BE RETURNED TO LOWER END OF SLOT (ORIGINAL POSITION) ON ROCK SHAFT ASSEMBLY.

25. Level Mower Housing

Adjust the mower while tractor is parked on level ground or driveway. Make sure tire pressures correct. If tires are over or under inflated, you will not properly adjust your mower.

Side-to-Side Mower Adjustment

- Depress lift lever plunger and use lift lever to raise mower to maximum cutting height.
- Measure height from bottom of curl to ground line at front of mower. Distance "A" should be the same on both sides (Fig. 32).
- If distance "A" needs to be changed, snap out access hole cover on L.H. side above footrest. Use 11/16" wrench on nuts "B" and "C" at side-to-side adjustment trunnion (Fig. 33).
- To raise left side of mower, loosen nut "B" and tighten nut "C".
- To lower left side of mower, loosen nut "C" and tighten nut "B".

REPAIR AND ADJUSTMENT

NOTE: ONE ROTATION OF ADJUSTMENT NUTS IS EQUIVALENT TO APPROXIMATELY 3/16" HEIGHT CHANGE.

- f. Be sure all nuts are securely tightened.
- g. Replace cover.

Front-To-Rear Mower Adjustment

- a. To obtain the best cutting results, your mower housing should be adjusted so the front and rear flange distance "D" (Fig. 34) is 1/2" lower in front when the mower is positioned in the highest cutting position.

NOTE: MEASURE DISTANCE "D" FROM GROUND LINE TO BOTTOM OF CURL ON RIGHT REAR FLANGE AND COMPARE TO DISTANCE "D" AT BOTTOM OF CURL ON RIGHT FRONT FLANGE.

- b. To raise rear of mower, loosen nut "E" on both rear suspension arms. Screw both nuts "F" up EQUAL NUMBER OF TURNS (Fig. 35)
- c. When distance "D" is 1/2" lower at front than rear tighten nuts "E".
- d. To lower rear of mower, loosen nut "F" on both rear suspension arms an EQUAL NUMBER OF TURNS (Fig. 35).
- e. When distance "D" is 1/2" lower at front than rear, retighten nuts "E"

NOTE: WHEN ADJUSTING REAR SUSPENSION TRUNNIONS, ALWAYS ADJUST BOTH EQUALLY SO MOWER WILL STAY LEVEL.

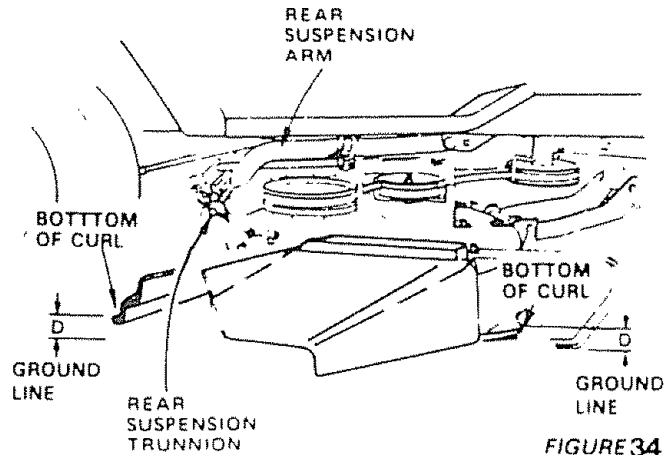

FIGURE 34

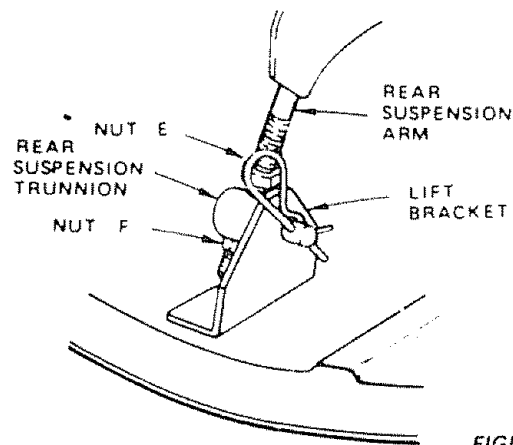

FIGURE 35

26. Storage

Remove mower from tractor for winter storage. When mower is to be stored for a period of time, clean it thoroughly, remove all dirt, grease, leaves, etc give blades and underside of housing a good coat of grease or rust preventative. Store in a clean dry area

A. Fuel System

It is important to prevent gum deposits from forming in essential fuel system parts such as the carburetor, fuel filter, fuel hose, or tank during storage. Also, experience indicates that alcohol blended fuels (called gasohol or using ethanol or methanol) can attract moisture which leads to separation and formation of acids during storage. Acidic gas can damage the fuel system of an engine while in storage. To avoid engine problems, the fuel system should be emptied before storage of 30 days or longer.

B. Engine Oil

Drain (with engine warm) and replace with clean engine oil, (See chart page 16).

C. Cylinder

1. Remove spark plug.
2. Pour one ounce of oil through spark plug hole into cylinder.
3. Turn ignition key to "START" position for a few seconds to distribute oil.
4. Replace with new spark plug.

D. Battery

1. Prior to storage, clean terminals and top of battery.
2. Disconnect cable from positive side of battery.

E. General Cleaning

Clean engine, battery, seat, finish, etc. of all foreign matter.

F. Store in a clean, dry area.

REPAIR AND ADJUSTMENT

LUBRICATION CHART

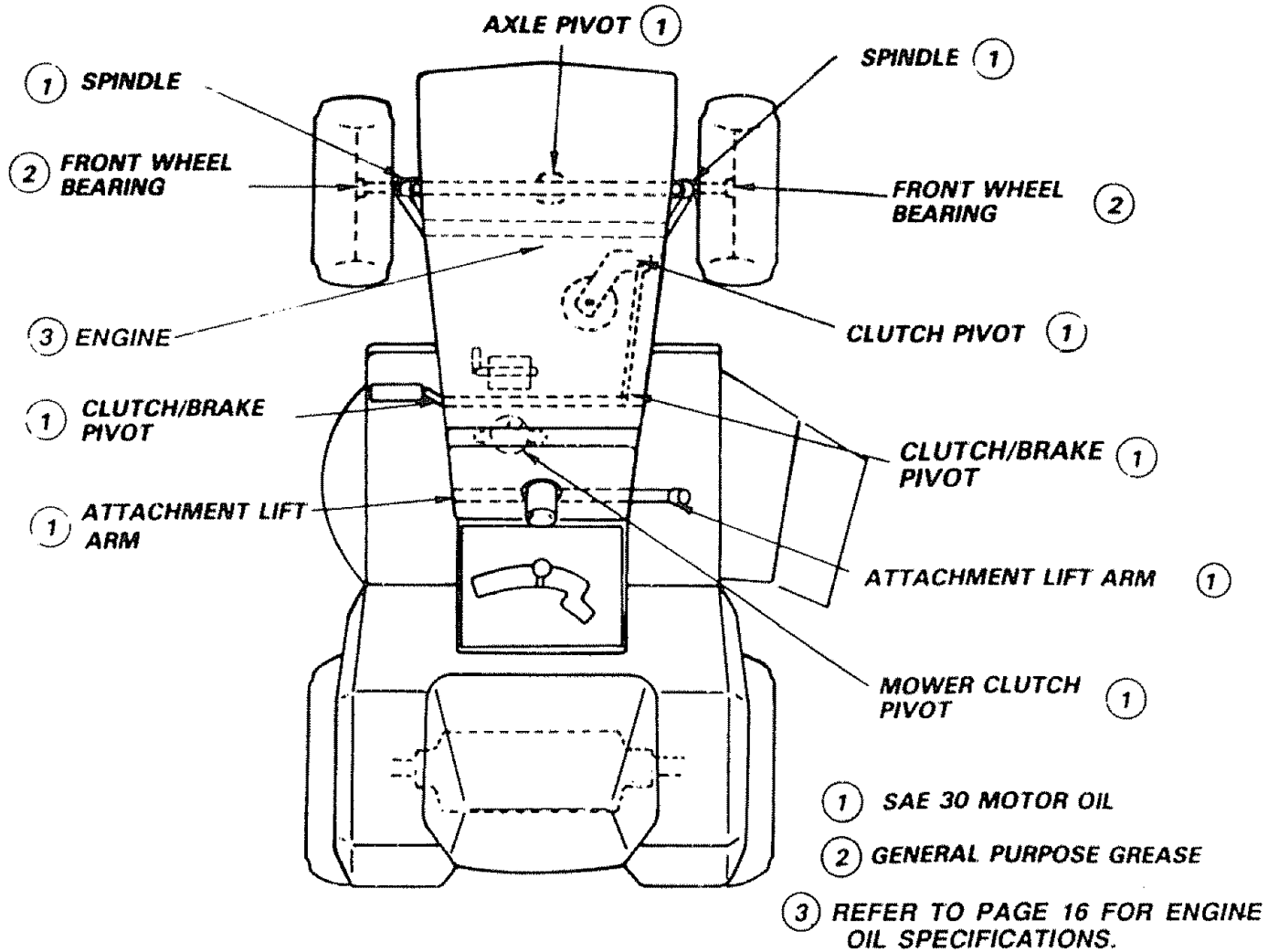

TROUBLESHOOTING

PROBLEM	CAUSE/REMEDY (SEE INDEX)
WILL NOT START	<p><i>Push Clutch/Brake Pedal into Brake Position</i> <i>Move Attachment Clutch Lever to "Disengaged Position</i> <i>Fill Fuel Tank with Gasoline Check Fuel Line and Carburetor</i> <i>(clean if necessary) Replace Fuel Filter</i> <i>Check fuse for fault and replace</i> <i>Recharge or replace Battery</i> <i>Check Wiring</i> <i>Replace Spark Plug and adjust gap</i> <i>Adjust valves</i></p>
WILL NOT TURN OVER	<p><i>Charge Battery</i> <i>Replace Ignition Switch</i> <i>Depress Clutch/Brake Pedal</i> <i>Disengage Attachment Clutch Lever</i> <i>Replace Interlock Switch</i> <i>Replace Solenoid</i> <i>Replace Fuse</i> <i>Check All Wire Connections</i></p>
ENGINE CLICKS BUT WON'T START	<p><i>Replace Starter</i> <i>Charge or Replace Battery</i></p>
HARD TO START	<p><i>Place Throttle Control in "FAST" position</i> <i>and run starter several times to clear out gas</i> <i>Remove and clean Fuel Tank and lines Replace Fuel Filter</i> <i>Remove Air Filter and clean</i> <i>Replace Spark Plug and adjust gap</i> <i>Replace Battery</i> <i>Check the wiring and Spark Plug</i> <i>Drain Fuel Tank and Carburetor. use fresh fuel and</i> <i>replace Spark Plug</i> <i>Make necessary adjustments to Carburetor</i> <i>Adjust valves</i> <i>Major Engine Overhaul</i></p>
ENGINE MISSES OR LACKS POWER	<p><i>Shift to a lower gear or reduce load</i> <i>Remove and clean Fuel Tank. replace Fuel Filter</i> <i>Remove and clean Air Cleaner</i> <i>Make necessary carburetor adjustments</i> <i>Clean Air Screen</i> <i>Add or change oil</i> <i>Replace Spark Plug</i> <i>Check Spark Plug and check for loose wires</i> <i>Major Engine overhaul</i> <i>Drain Fuel Tank and Carburetor and refill</i> <i>Adjust valves</i></p>
ENGINE OVERHEATS	<p><i>Clean Air Screen</i> <i>Add or change oil</i> <i>Clean Engine Cooling Fins</i> <i>Remove and clean Muffler or replace</i> <i>Remove and clean Air Filter</i> <i>Use fresh fuel and adjust Carburetor</i></p>
NO LIGHTS	<p><i>Check Fuse, Switch and wire connections Replace</i> <i>Headlight Bulbs</i></p>
WON'T CHARGE	<p><i>Check Fuse and replace</i> <i>Replace Battery</i> <i>Replace Regulator</i> <i>Replace Alternator</i></p>
<p>OPERATOR PRESENCE SYSTEM WILL NOT SHUT DOWN WHEN OPERATOR LEAVES SEAT. <i>Note: This tractor is equipped with an operator presence sensing system.</i> <i>Any attempt by the operator to leave the seat with the engine running and the attachment clutch engaged will shut down the engine.</i></p>	<p><i>Engage attachment clutch</i> <i>Check all wire connections</i> <i>Check seat switch Check operator presence relay</i> <i>Check PTO Switch</i></p>

TROUBLESHOOTING

<p>UNSATISFACTORY MOWER PERFORMANCE UNEVEN DISTRIBUTION OF CLIPPINGS</p>	<p><i>Place Throttle Control in "FAST" position Check air pressure in tires Check front to rear and side to side mower adjustment Use a slower ground speed Check engines RPM's (refer to Carburetor Adjustment) Replace mower blades Reinstall mower blades with top of blade up Replace with proper mower blades Re-adjust mower drive belt</i></p>
<p>MOWER BLADES WILL NOT ROTATE</p>	<p><i>Install new Mower Drive Belt Reinstall Mower Drive Belt Adjust Mower Drive Belt Replace Frozen Mandrel Replace Frozen Idler Pulley</i></p>
<p>EXCESSIVE MOWER VIBRATION</p>	<p><i>Replace Bent or Unbalanced Blades Replace Mandrel, Straighten Deck or replace</i></p>
<p>WIND ROWING STRIPPING OR DROPPING OF GRASS CLIPPINGS</p>	<p><i>Let grass dry out Clean underside of Mower Deck Readjust Mower</i></p>
<p>UNEVEN CUT OR SCALPING</p>	<p><i>Readjust Mower</i></p>