

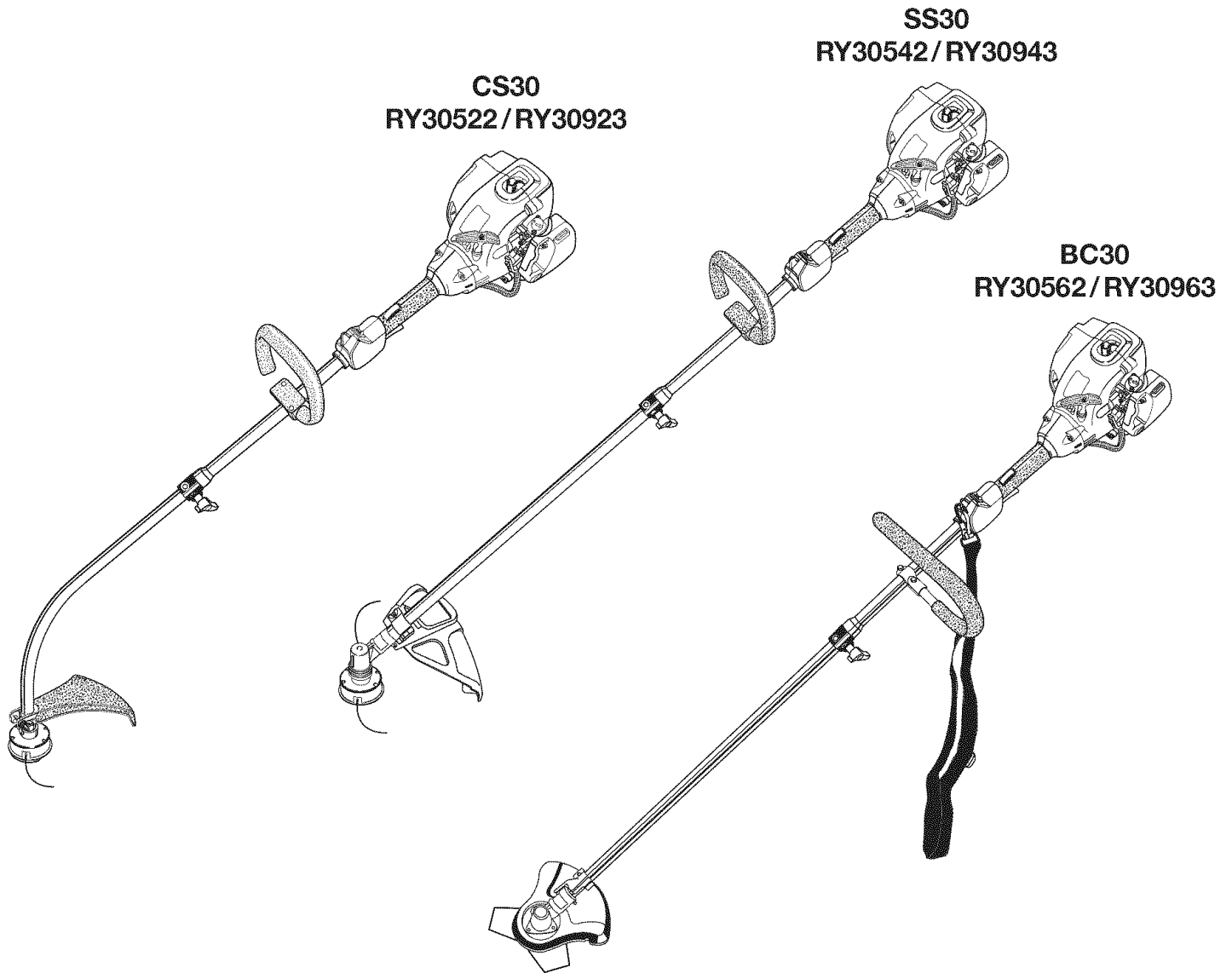

OPERATOR'S MANUAL

30cc String Trimmers and Brushcutters



Your new trimmer has been engineered and manufactured to our high standard for dependability, ease of operation, and operator safety. Properly cared for, it will give you years of rugged, trouble-free performance.

⚠ WARNING: To reduce the risk of injury, the user must read and understand the operator's manual before using this product.

Thank you for your purchase.

SAVE THIS MANUAL FOR FUTURE REFERENCE

TABLE OF CONTENTS

■ Introduction	2
■ General Safety Rules.....	3
■ Specific Safety Rules	4
■ Symbols	5-6
■ Features	7-9
■ Assembly.....	9-14
■ Operation.....	14-18
■ Maintenance	19-21
■ Troubleshooting.....	22-23
■ Warranty	23-25
■ Service Parts	Back Page

INTRODUCTION

This product has many features for making its use more pleasant and enjoyable. Safety, performance, and dependability have been given top priority in the design of this product making it easy to maintain and operate.

GENERAL SAFETY RULES

WARNING:

Read and understand all instructions. Failure to follow all instructions listed below may result in electric shock, fire and/or serious personal injury.

READ ALL INSTRUCTIONS

- For safe operation, read and understand all instructions before using this product. Follow all safety instructions. Failure to follow all safety instructions listed below, can result in serious personal injury.
- Do not allow children or untrained individuals to use this unit.
- Never start or run the engine in a closed or poorly ventilated area; breathing exhaust fumes can kill.
- Clear the work area before each use. Remove all objects such as rocks, broken glass, nails, wire, or string which can be thrown or become entangled in the cutting line or blade.
- Wear safety glasses or goggles that are marked to comply with ANSI Z87.1 standard when operating this product.
- Wear heavy, long pants, boots, and gloves. Do not wear loose fitting clothing, short pants, sandals, or go barefoot. Do not wear jewelry of any kind.
- Product users on United States Forest Service land, and in some states, must comply with fire prevention regulations. This product is equipped with a spark arrestor; however, other user requirements may apply. Check with your federal, state, or local authorities.
- Never operate this unit on the operator's left side.
- Secure long hair above shoulder level to prevent entanglement in moving parts.
- Keep all bystanders, children, and pets at least 50 ft. away. Bystanders should be encouraged to wear eye protection.
- Do not operate this unit when you are tired, ill, or under the influence of alcohol, drugs, or medication.
- Do not operate in poor lighting.
- Keep firm footing and balance. Do not overreach. Overreaching can result in loss of balance or exposure to hot surfaces.
- Keep all parts of your body away from any moving part.
- To avoid hot surfaces, never operate the unit with the bottom of the engine above waist level.
- Do not touch area around the muffler or cylinder of the unit, these parts get hot from operation.
- Always stop the engine and remove the spark plug wire before making any adjustments or repairs except for carburetor adjustments. Wear your protective equipment and observe all safety instructions. When the unit is turned off, make sure the cutting attachment has stopped before setting the unit down.
- Inspect the unit before each use for loose fasteners, fuel leaks, etc. Replace any damaged parts before use.
- The string head or blade will rotate during carburetor adjustments.
- It has been reported that vibrations from hand-held tools may contribute to a condition called Raynaud's Syndrome in certain individuals. Symptoms may include tingling, numbness, and blanching of the fingers, usually apparent upon exposure to cold. Hereditary factors, exposure to cold and dampness, diet, smoking, and work practices are all thought to contribute to the development of these symptoms. It is presently unknown what, if any, vibrations or extent of exposure may contribute to the condition. There are measures that can be taken by the operator to possibly reduce the effects of vibration:
 - a) Keep your body warm in cold weather. When operating the unit wear gloves to keep hands and wrists warm. It is reported that cold weather is a major factor contributing to Raynaud's Syndrome.
 - b) After each period of operation, exercise to increase blood circulation.
 - c) Take frequent work breaks. Limit the amount of exposure per day.
 - d) Keep the tool well maintained, fasteners tightened, and worn parts replaced.If you experience any of the symptoms of this condition, immediately discontinue use and see your physician about these symptoms.
- Mix and store fuel in a container approved for gasoline.
- Mix fuel outdoors where there are no sparks or flames. Wipe up any fuel spillage. Move 30 ft. away from refueling site before starting engine. Slowly remove the fuel cap after stopping engine. Do not smoke when refueling.
- Stop the engine and allow to cool before refueling or storing the unit.
- Allow the engine to cool; empty the fuel tank and secure the unit from moving before transporting in a vehicle.

SPECIFIC SAFETY RULES

SPECIFIC SAFETY RULES FOR TRIMMER USE

- Replace string head if cracked, chipped, or damaged in any way. Be sure the string head or blade is properly installed and securely fastened. Failure to do so can cause serious injury.
- Make sure all guards, straps, deflectors, and handles are properly and securely attached.
- Use only the manufacturer's replacement string in the cutting head. Do not use any other cutting attachment. To install any other brand of replacement string or cutting head to this string trimmer can result in serious personal injury.
- Never operate unit without the grass deflector in place and in good condition.
- Maintain a firm grip on both handles while trimming. Keep string head below waist level. Never cut with the string head located over 30 in. or more above the ground.









SPECIFIC SAFETY RULES FOR BRUSH-CUTTER AND BLADE USE

- After engine stops, keep rotating blade in thicker weeds or pulpy stalks until it stops.
- Do not operate the brushcutter unless the brushcutter guard is firmly secured in place and in good condition.
- Use heavy gloves when operating the brushcutter and when installing or removing blades.
- Always stop the engine and remove the spark plug wire before attempting to remove any obstruction caught or jammed in the blade or before removing and installing the blade.
- Do not attempt to touch or stop the blade when it is rotating.
- A coasting blade can cause injury while it continues to spin after the engine is stopped or throttle trigger released. Maintain proper control until the blade has completely stopped rotating.

- Replace any blade that has been damaged. Always make sure blade is installed correctly and securely fastened before each use. Failure to do so can cause serious injury.
- Use only the manufacturer's replacement Tri-Arc® blade intended for use on this brushcutter. Do not use any other blade. To install any other brand blade or cutting head to this brushcutter can result in serious personal injury.
- The Tri-Arc® blade is suited for cutting thicker weeds or pulpy stalks only. Do not use for any other purpose. Never use the Tri-Arc® blade to cut woody brush.
- Exercise extreme caution when using the blade with this unit. Blade thrust is the reaction that may occur when the spinning blade contacts anything it cannot cut. This contact may cause the blade to stop for an instant, and suddenly "thrust" the unit away from the object that was hit. This reaction can be violent enough to cause the operator to lose control of the unit. Blade thrust can occur without warning if the blade snags, stalls, or binds. This is more likely to occur in areas where it is difficult to see the material being cut. For cutting ease and safety, approach the weeds being cut from the right to the left. In the event an unexpected object or woody stock is encountered, this could minimize the blade thrust reaction.
- Never cut any material over 1/2 in. diameter.
- Always wear the shoulder harness when using the brushcutter and adjust to a comfortable operating position. Maintain a firm grip on both handles while cutting with a blade. Keep the blade away from your body and below waist level.
- Never use the brushcutter with the blade located 30 in. or more above the ground level.



SYMBOLS

Some of the following symbols may be used on this product. Please study them and learn their meaning for safe operation of this product.

SYMBOL	NAME	EXPLANATION
	Safety Alert	Precautions that involve your safety.
	Read the Operator's Manual	To reduce the risk of injury, user must read and understand operator's manual before using this product.
	Wear Eye and Hearing Protection	Wear eye protection which is marked to comply with ANSI Z87.1 as well as hearing protection when operating this equipment.
	Keep Bystanders Away	Keep all bystanders at least 50 ft. away.
	Ricochet	Thrown objects can ricochet and result in personal injury or property damage.
	No Blade	Do not install or use any type of blade on a product displaying this symbol.
	Blade Thrust	Beware of blade thrust. Products authorized for blade use will display this symbol to warn of blade thrust.
	Gasoline and Oil	Use unleaded gasoline intended for motor vehicle use with an octane rating of 87 [(R + M) / 2] or higher. This product is powered by a 2-cycle engine and requires pre-mixing gasoline and 2-cycle oil.

SYMBOLS

The following signal words and meanings are intended to explain the levels of risk associated with this product.

SYMBOL	SIGNAL	MEANING
	DANGER:	Indicates an imminently hazardous situation, which, if not avoided, will result in death or serious injury.
	WARNING:	Indicates a potentially hazardous situation, which, if not avoided, could result in death or serious injury.
	CAUTION:	Indicates a potentially hazardous situation, which, if not avoided, may result in minor or moderate injury.
	CAUTION:	(Without Safety Alert Symbol) Indicates a situation that may result in property damage.

SERVICE

Servicing requires extreme care and knowledge and should be performed only by a qualified service technician. For service we suggest you return the product to your nearest **AUTHORIZED SERVICE CENTER** for repair. When servicing, use only identical replacement parts.



WARNING:

To avoid serious personal injury, do not attempt to use this product until you read thoroughly and understand completely the operator's manual. If you do not understand the warnings and instructions in the operator's manual, do not use this product. Call Ryobi customer service for assistance.



WARNING:



The operation of any power tool can result in foreign objects being thrown into your eyes, which can result in severe eye damage. Before beginning power tool operation, always wear safety goggles or safety glasses with side shields and, when needed, a full face shield. We recommend Wide Vision Safety Mask for use over eyeglasses or standard safety glasses with side shields. Always use eye protection which is marked to comply with ANSI Z87.1.

SAVE THESE INSTRUCTIONS

FEATURES

PRODUCT SPECIFICATIONS

Weight - (without fuel)

CS30	10.7 lbs.
SS30	12.1 lbs.
BC30	12.9 lbs.

String cutting width

CS30	17 in.
SS30	18 in.
BC30	18 in.

Blade cutting width

BC30	8 in.
------------	-------

Engine displacement

.....	30cc
-------	------

String diameter

CS30080 in.
SS30095 in.
BC30095 in.

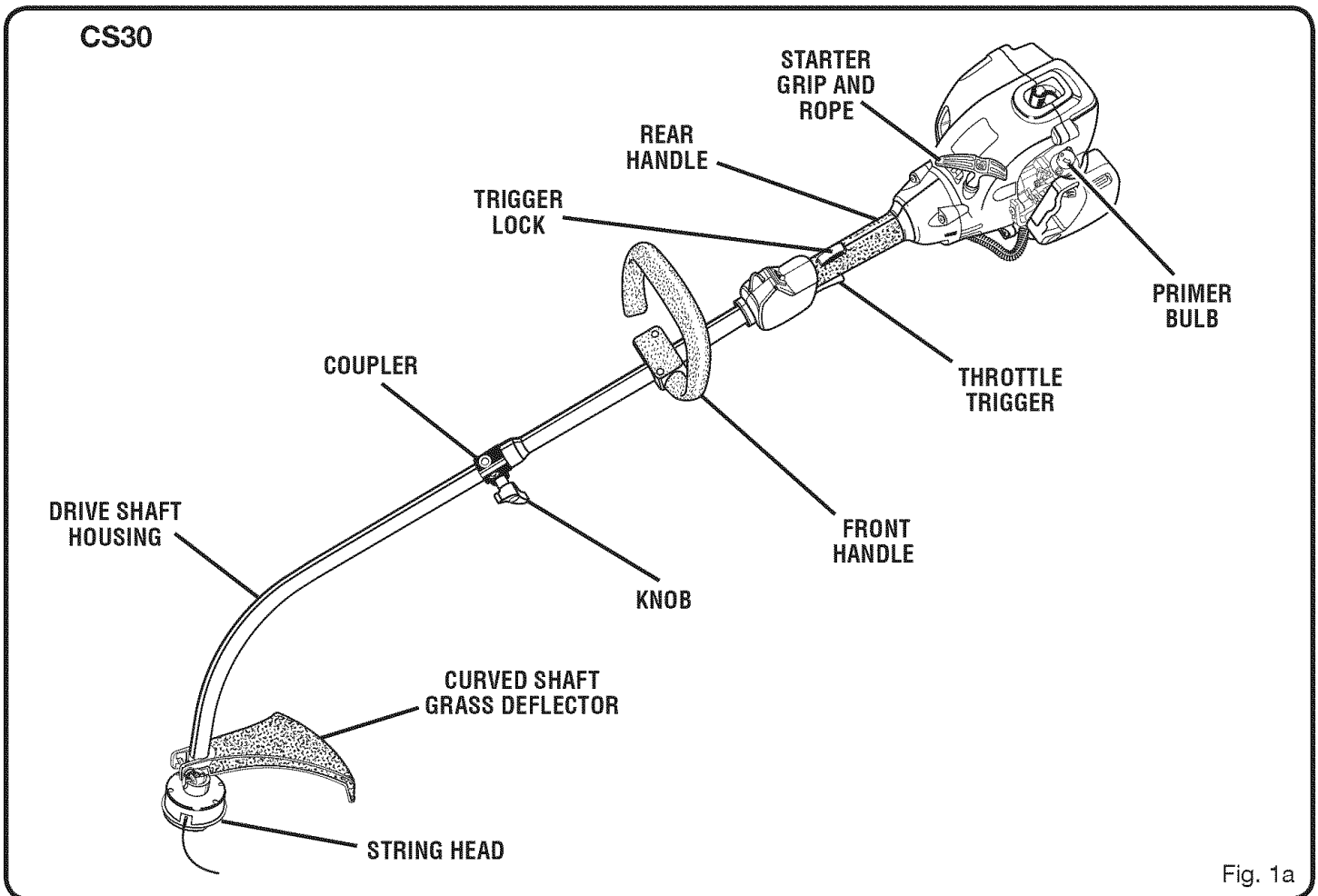

FEATURES

SS30

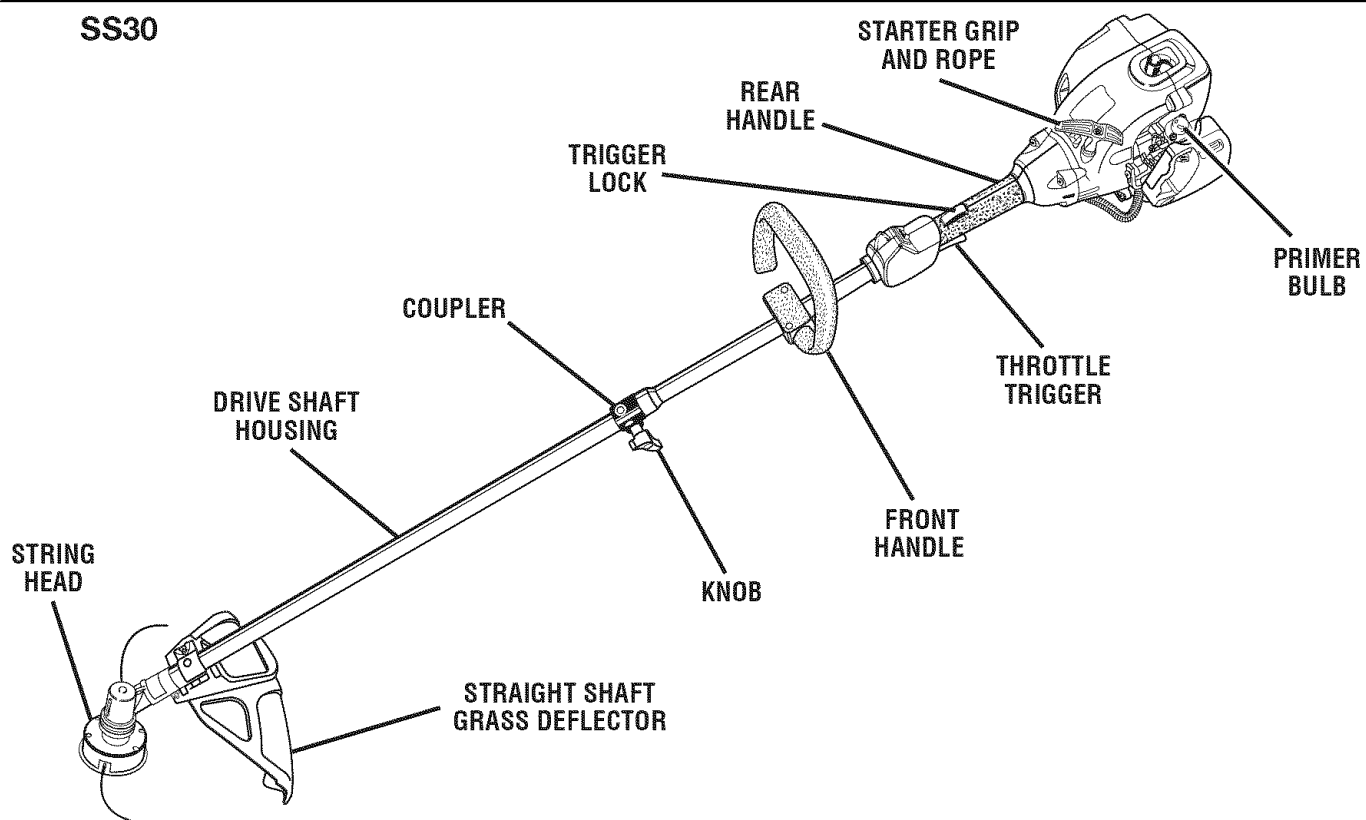

Fig. 1b

BC30

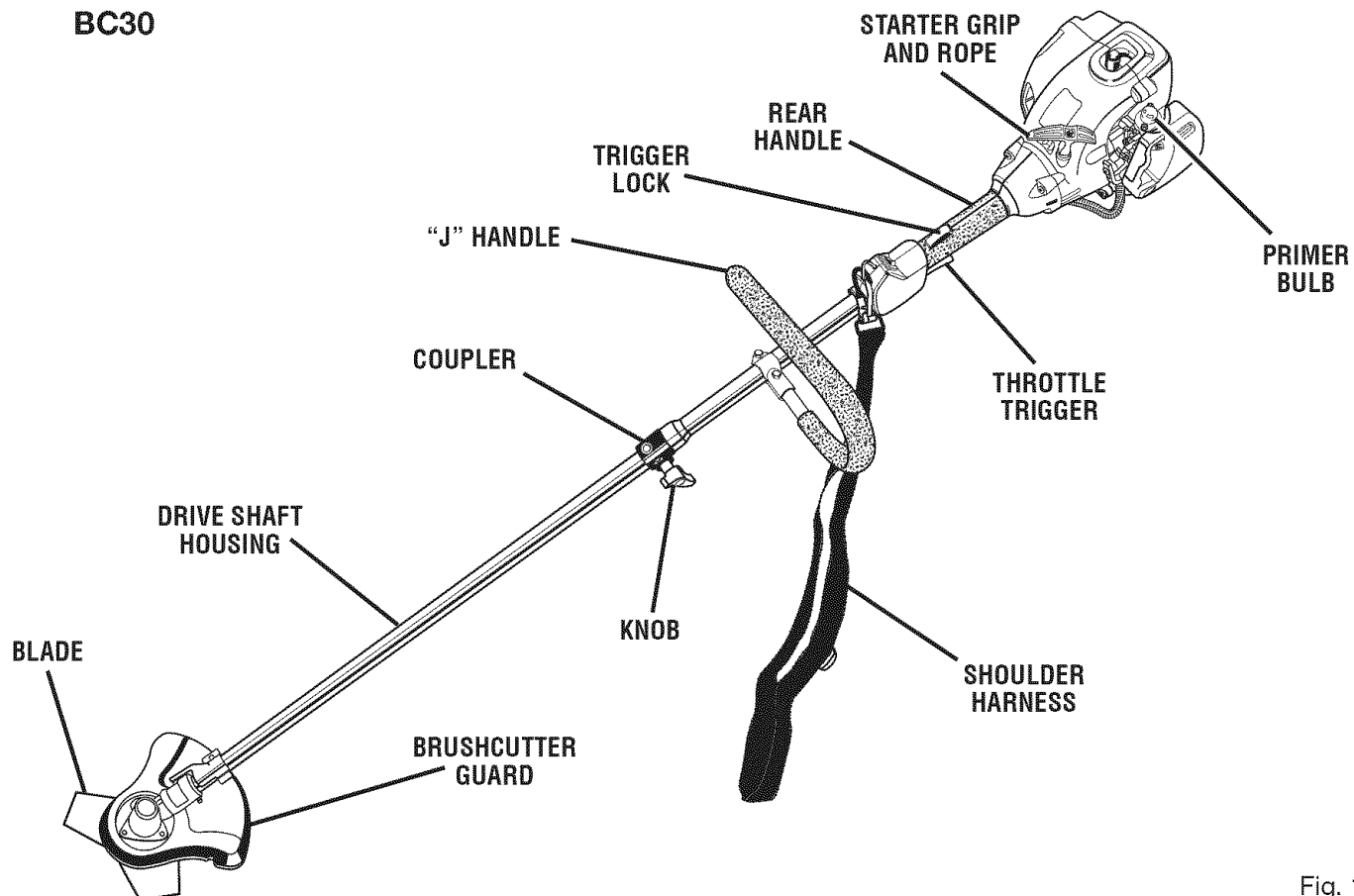

Fig. 1c

FEATURES

KNOW YOUR STRING TRIMMER

See Figures 1a - 1c.

The safe use of this product requires an understanding of the information on the tool and in this operator's manual as well as a knowledge of the project you are attempting. Before use of this product, familiarize yourself with all operating features and safety rules.

ERGONOMIC DESIGN

The design of the trimmer provides for easy handling. It is designed for comfort and ease of grasp when operating in different positions and at different angles.

GRASS DEFLECTOR

The trimmer includes a grass deflector that helps protect you from flying debris.

TOP-MOUNTED MOTOR

The top-mounted motor improves balance and is located away from the dust and debris of the cutting area.

ASSEMBLY

UNPACKING

This product requires assembly.

- Carefully remove the tool and any accessories from the box. Make sure that all items listed in the packing list are included.
- Inspect the tool carefully to make sure no breakage or damage occurred during shipping.
- Do not discard the packing material until you have carefully inspected and satisfactorily operated the tool.
- If any parts are damaged or missing, please call 1-800-860-4050 for assistance.

PACKING LIST

Trimmer Assembly - CS30 and SS30
Brushcutter Assembly - BC30
Front handle - CS30 and SS30
"J" Handle - BC30
Curved Shaft Grass Deflector
Straight Shaft Grass Deflector - SS30 and BC30
Gear Head Locking Tool - BC30
Shoulder Harness - BC30
String Head Assembly - BC30
Bottle of 2-Cycle Oil
Hanger Cap
Operator's Manual

WARNING:

If any parts are damaged or missing do not operate this tool until the parts are replaced. Failure to heed this warning could result in serious personal injury.

WARNING:

Do not attempt to modify this tool or create accessories not recommended for use with this tool. Any such alteration or modification is misuse and could result in a hazardous condition leading to possible serious personal injury.

WARNING:

To prevent accidental starting that could cause serious personal injury, always disconnect the engine spark plug wire from the spark plug when assembling parts.

ASSEMBLY

INSTALLING THE POWER HEAD TO THE ATTACHMENT

See Figure 2.

WARNING:

Never install, remove, or adjust any attachment while power head is running. Failure to stop the engine can cause serious personal injury.

The attachment connects to the power head by means of a coupler device.

- Loosen the knob on the coupler of the power head shaft and remove the end cap from the attachment.
- Push in the button located on the attachment shaft. Align the button with the guide recess on the power head coupler and slide the two shafts together. Rotate the attachment shaft until the button locks into the positioning hole.

NOTE: If the button does not release completely in the positioning hole, the shafts are not locked into place. Slightly rotate from side to side until the button is locked into place.

- Tighten the knob securely.

WARNING:

Be certain the knob is fully tightened before operating equipment; check it periodically for tightness during use to avoid serious personal injury.

REMOVING THE ATTACHMENT FROM THE POWER HEAD

For removing or changing the attachment:

- Loosen the knob.
- Push in the button and twist the shafts to remove and separate ends.

ATTACHING THE STORAGE HANGER

See Figure 3.

There are two ways to hang your attachment for storage.

- To use the hanger cap, push in the button and place the hanger cap over end of the lower end attachment shaft. Slightly rotate the cap from side to side until the button locks into place.
- The secondary hole in the attachment shaft can be used for hanging purposes as well.

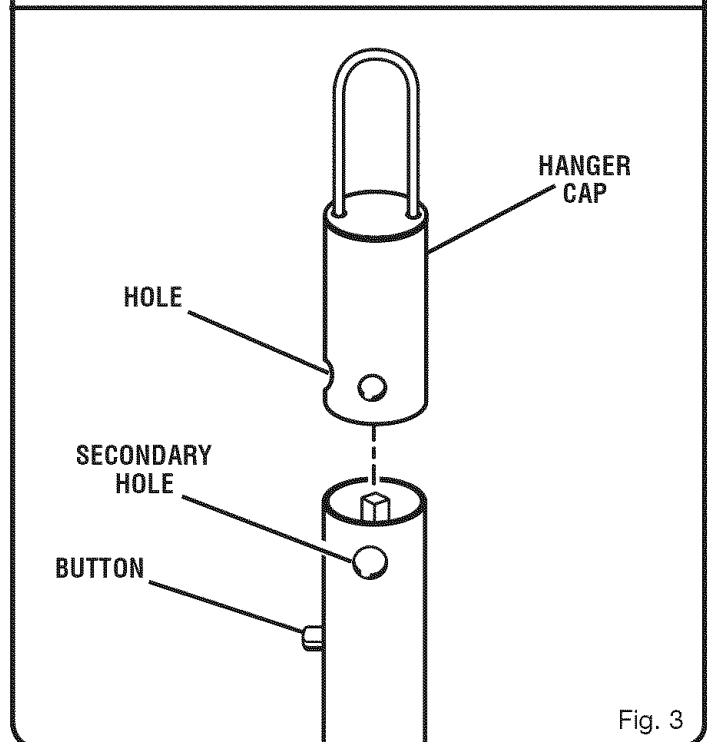
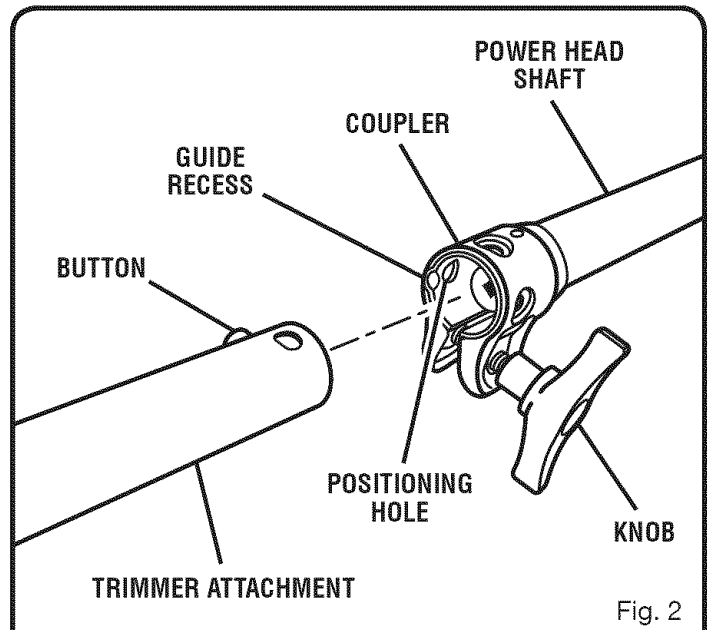

ASSEMBLY

ATTACHING THE FRONT HANDLE - CS30 AND SS30

See Figure 4.

- Remove 2 wing nuts, 2 bolts, and clamp from the front handle.
- Install the front handle onto the top side of the drive shaft housing and move it to a comfortable position.
- Place the bolt through the front handle.
NOTE: The hex bolt head fits inside the hex recess molded into one side of the handle.
- Reinstall the clamp, bolts, and wing nuts.
- Tighten wing nut securely.

ATTACHING THE “J” HANDLE - BC30

See Figure 5.

A “J” handle must be used for ensuring the best control and maximizing operator safety when using a brushcutter.

- Hold the top and bottom clamp snugly in position on the shaft housing so that handle will be located to the operator’s left.
- Insert the end of the handle between the clamps.
- Align the bolt holes and push the long bolt (1/4-20 x 1-1/2 in.) through the handle side.
- Place short bolt (1/4-20 x 1 in.) through opposite side of clamp. Install flat washers, lock washers, and hex nuts to hold the assembly in place.
- After assembly is complete, adjust the position of the handle for best balance and comfort.
- Tighten first the long bolt and then the short bolt.

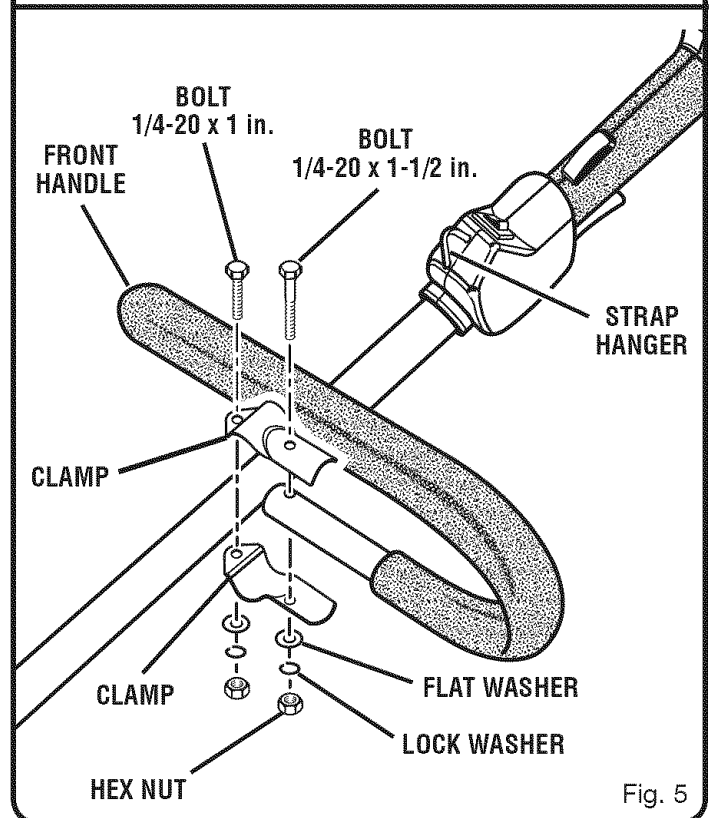
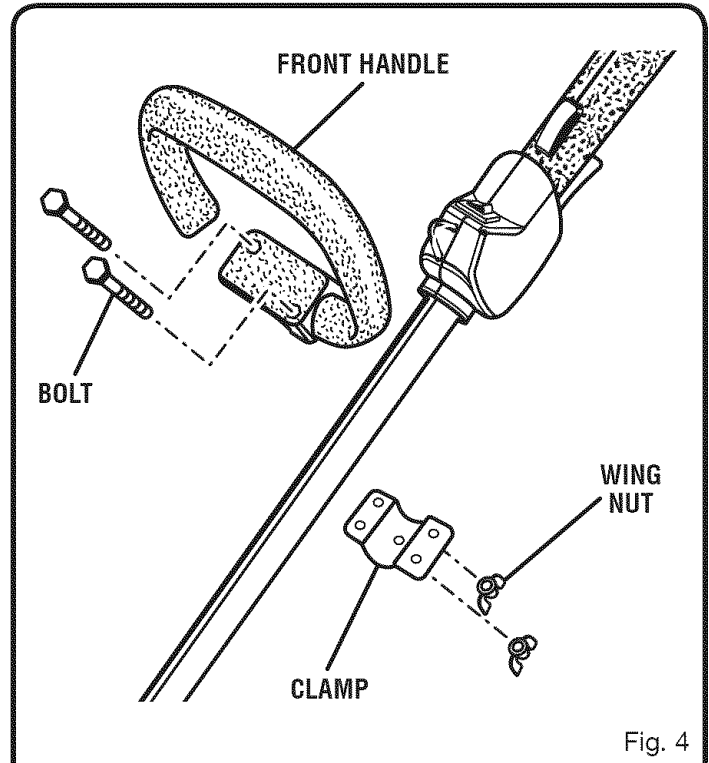

ASSEMBLY

ATTACHING THE GRASS DEFLECTOR

⚠ WARNING:

The line cutting blade on the grass deflector is sharp. Avoid contact with the blade. Failure to avoid contact can result in serious personal injury.

TO ATTACH THE CURVED SHAFT GRASS DEFLECTOR - CS30

See Figure 6.

- Remove hex screw, flat washer, lock washer, and wing nut from grass deflector.
- Press the grass deflector onto the bottom of the curved shaft as shown.
- Insert the hex screw through the grass deflector and the bracket on the curved shaft.
- Place the flat washer and lock washer on the hex head cap screw.
- Place the wing nut on the hex head cap screw and tighten securely.

TO ATTACH THE STRAIGHT SHAFT GRASS DEFLECTOR - SS30

See Figure 7.

- Remove the wing screw from the grass deflector.
- Insert the tab on the mounting bracket in the slot on the grass deflector.
- Align the screw hole in the mounting bracket with the screw hole in the grass deflector.
- Insert the wing screw through the mounting bracket and into the grass deflector.
- Tighten the screw securely.

ATTACHING THE BRUSHCUTTER GUARD - BC30

See Figure 8.

The guard is shipped installed on these brushcutter models. Instructions have been included for reference when changing from string trimmer operation back to brushcutter operation.

- With the string head removed, place the brushcutter guard on the gear head as shown.
- Install the three hex head screws from bottom through the guard and into the gear head.
- Tighten the screws securely and torque to 40-50 in.lb. minimum.

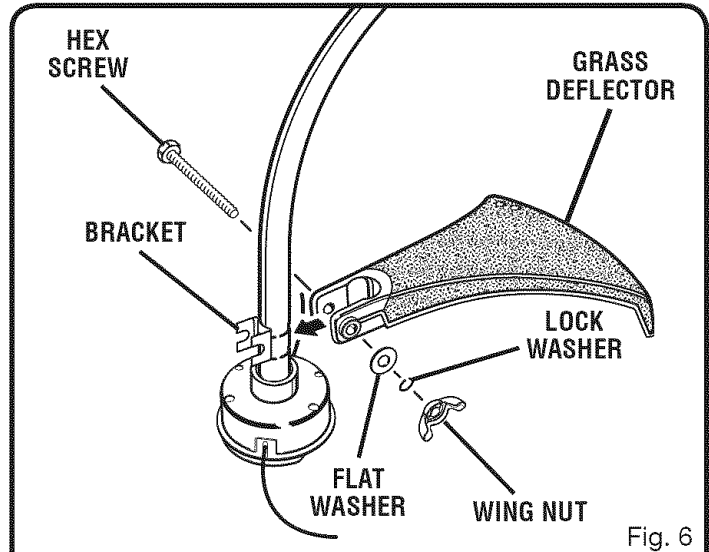

Fig. 6

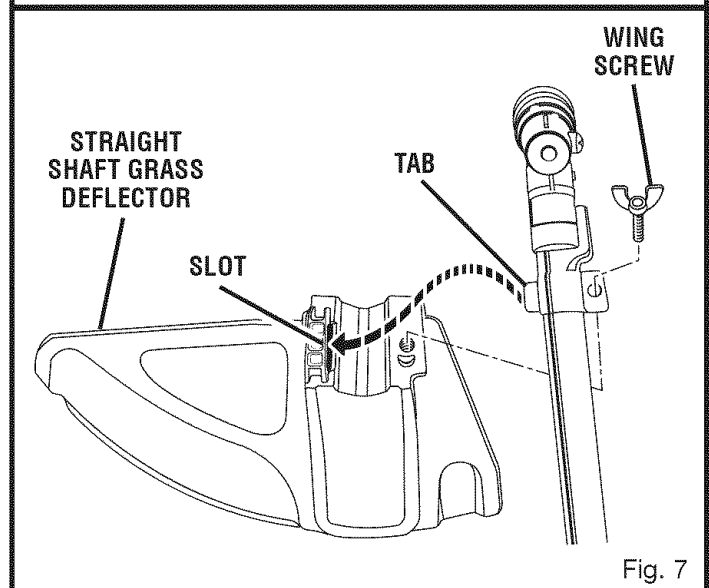

Fig. 7

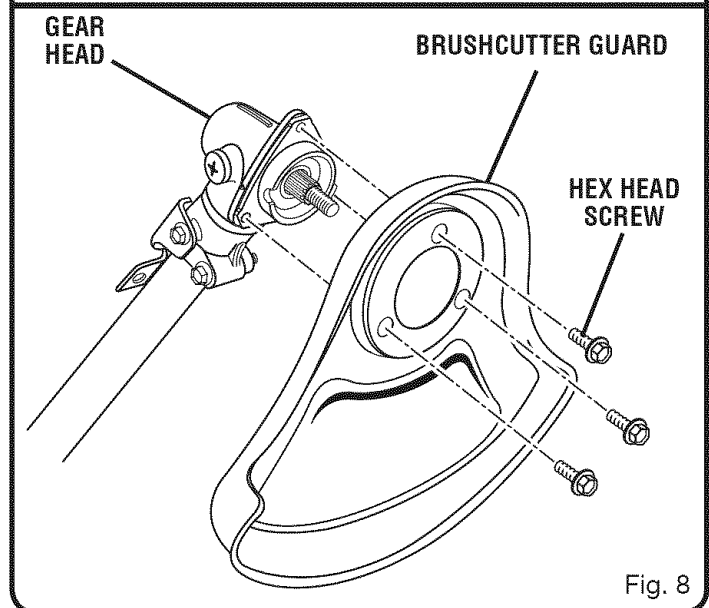

Fig. 8

ASSEMBLY

ATTACHING THE SHOULDER HARNESS - BC30

See Figure 9.

- Connect the latch on the shoulder harness to the strap hanger.
- Adjust the strap to a comfortable position.

CONVERTING FROM BRUSHCUTTER TO STRING TRIMMER - BC30

To convert from the brushcutter to the string trimmer, remove the blade and brushcutter guard, attach the straight shaft grass deflector and install the string head.

REMOVING THE TRI-ARC® BLADE AND BRUSHCUTTER GUARD

See Figures 10 - 11.

- Align the slot in the flanged washer with the slot in the gear head.
- Place the gear head locking tool through the slot in the flanged washer and gear head.
- Remove the blade nut by turning it clockwise.
- Remove the cupped washer and the blade.
- Remove the flanged washer from the gear head shaft and retain it for the string head installation.
- Remove the three screws securing the brushcutter guard to gear head.
- Remove the brushcutter guard.

NOTE: Store the brushcutter parts together for later use.

INSTALLING THE STRAIGHT SHAFT GRASS DEFLECTOR AND STRING HEAD

See Figures 10 - 12.

- Install the grass deflector. Refer to **To Attach the Straight Shaft Grass Deflector** earlier in this manual.
- Place the flanged washer on the gear head shaft.

NOTE: The hollow side of the flanged washer should face the gear head.

- Align the slot in the flanged washer with the slot in the gear head.
- Place the gear head locking tool through the slot in the flanged washer and gear head.
- Install the string head assembly onto the gear head shaft by turning counterclockwise.
- Tighten the string head assembly securely.

CONVERTING FROM STRING TRIMMER TO BRUSHCUTTER - BC30

To convert from the string trimmer to the brushcutter, remove the string head assembly and straight shaft grass deflector, attach the brushcutter guard and install the blade.

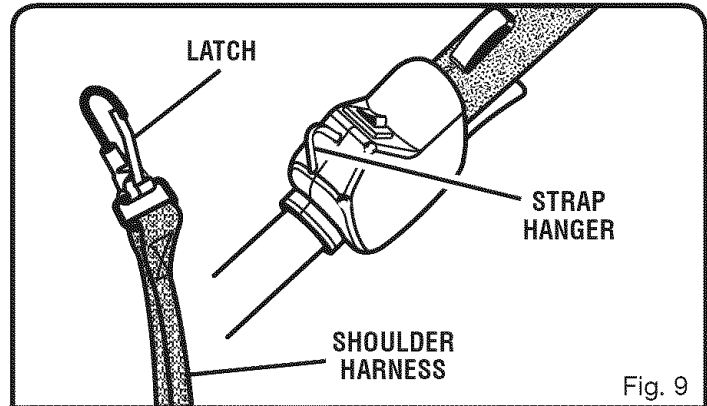

Fig. 9

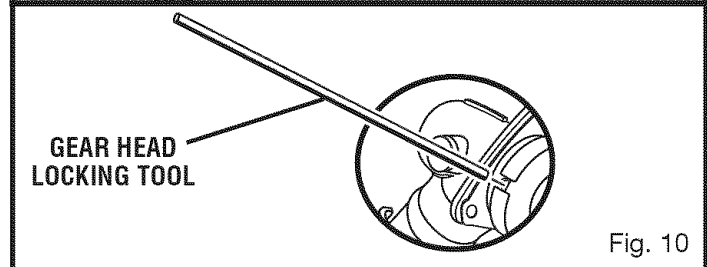

Fig. 10

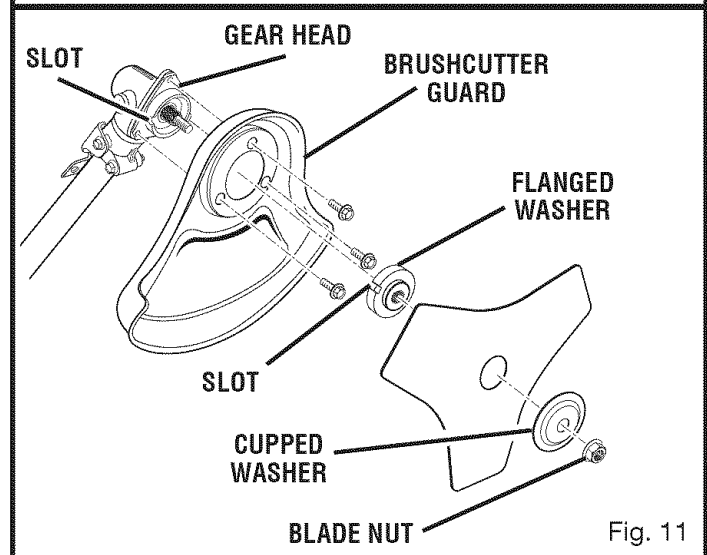

Fig. 11

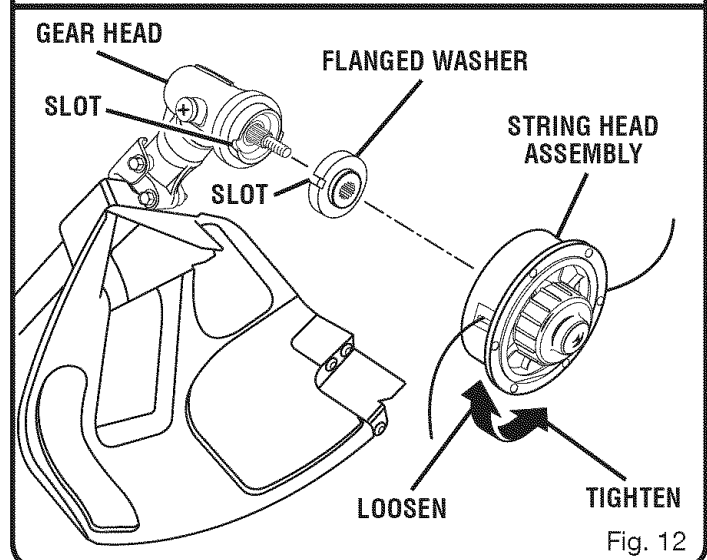

Fig. 12

ASSEMBLY

REMOVING THE STRAIGHT SHAFT GRASS DEFLECTOR AND STRING HEAD

See Figures 10 - 13.

- Align the slot in the flanged washer with the slot in the gear head.
- Place the gear head locking tool through the slot in the flanged washer and gear head.
- Remove the string head assembly by turning clockwise.
- Remove the flanged washer and retain it for the blade installation.
- Remove the wing screw securing the grass deflector.
- Remove the grass deflector.

NOTE: Store the string head parts together for later use.

INSTALLING THE TRI-ARC® BLADE AND BRUSHCUTTER GUARD

See Figures 10 - 14.

- Install the brushcutter guard. Refer to **Attaching the Brushcutter Guard** earlier in this manual.
- Place the flanged washer over the gear head shaft with the hollow side toward the brushcutter guard.
- Center the blade on the flanged washer, making sure the blade fits flat and the raised hub of the flanged washer goes through the hole in the blade.
- Install the cupped washer with the raised center away from the blade.
- Place the blade nut onto the gear head shaft.
- Place the gear head locking tool through the slot in the flanged washer and gear head.
- Install the blade nut by turning it counterclockwise (left handed threads).
- Tighten the blade nut securely and torque to 120 in.lbs. minimum.

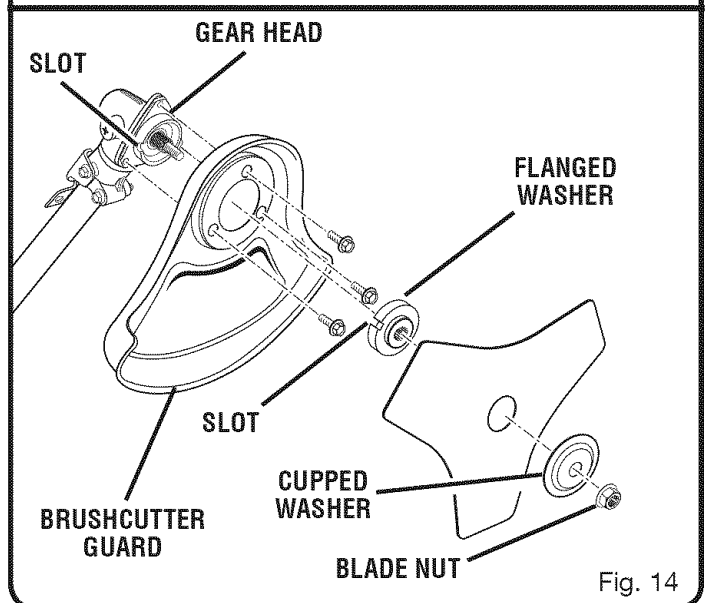
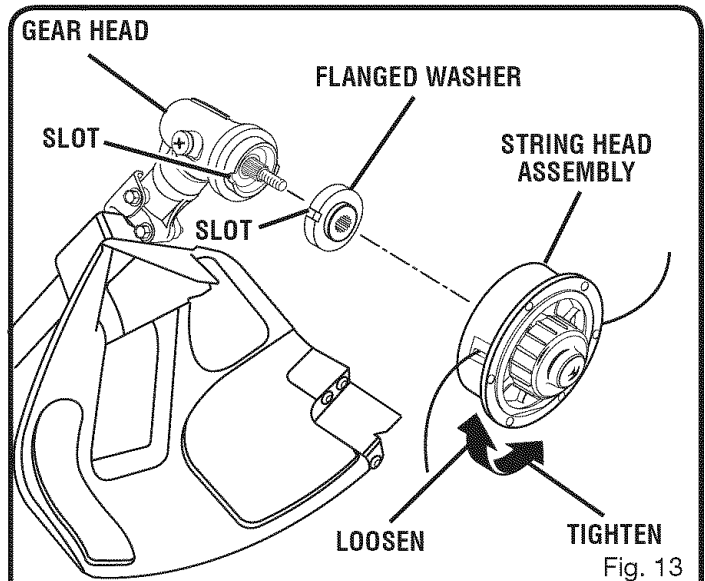

OPERATION

WARNING:

Do not allow familiarity with tools to make you careless. Remember that a careless fraction of a second is sufficient to inflict serious injury.

WARNING:

Always wear safety goggles or safety glasses with side shields when operating tools. Failure to do so could result in objects being thrown into your eyes, resulting in possible serious injury.

WARNING:

Do not use any attachments or accessories not recommended by the manufacturer of this tool. The use of attachments or accessories not recommended can result in serious personal injury.

OPERATION

FUELING AND REFUELING THE TRIMMER

FUEL MIXTURE

This product is powered by a 2-cycle engine and requires pre-mixing gasoline and 2-cycle oil. Pre-mix unleaded gasoline and 2-cycle engine oil in a clean 1 gallon container approved for gasoline.

Recommended fuel: This engine is certified to operate on unleaded gasoline intended for automotive use.

Mix a high quality 2-cycle engine oil at 2.6 oz. per gallon (US).

Do not use automotive oil or 2-cycle outboard oil.

DO NOT mix quantities larger than usable in a 30 day period.



HIGH QUALITY 2-CYCLE ENGINE OIL

GASOLINE	OIL
1 gallon (US)	2.6 oz.
1 liter	20 cc (20 ml)

FILLING TANK

- Clean surface around fuel cap to prevent contamination.
- Loosen fuel cap slowly. Rest the cap on a clean surface.
- Carefully pour fuel into the tank. Avoid spillage.
- Prior to replacing the fuel cap, clean and inspect the gasket.
- Immediately replace fuel cap and hand tighten. Wipe up any fuel spillage.

NOTE: It is normal for smoke to be emitted from a new engine after first use.

WARNING:

Always shut off engine before fueling. Never add fuel to a machine with a running or hot engine. Move at least 30 ft. from refueling site before starting engine. Do not smoke!

OPERATING THE TRIMMER

See Figure 15.

WARNING:

Always position the unit on the operator's right side. The use of the unit on the operator's left side will expose the user to hot surfaces and can result in possible burn injury.

WARNING:

To avoid burns from hot surfaces, never operate unit with the bottom of the engine above waist level.

Hold the trimmer with your right hand on the rear handle and your left hand on the front handle. Keep a firm grip with both hands while in operation. Trimmer should be held at a comfortable position with the rear handle about hip height.

Always operate trimmer at full throttle. Cut tall grass from the top down. This will prevent grass from wrapping around the shaft housing and string head which could cause damage from overheating. If grass becomes wrapped around the string head, STOP THE ENGINE, disconnect the spark plug wire, and remove the grass. Prolonged cutting at partial throttle will result in oil dripping from the muffler.

PROPER OPERATING POSITION



Fig. 15

OPERATION

WARNING:

Always hold the string trimmer away from the body keeping clearance between the body and the product. Any contact with the housing or string trimmer cutting head can result in burns and/or other serious personal injury.

TO ADVANCE THE CUTTING LINE

String advance is controlled by tapping the string head on grass while running engine at full throttle.

- Run engine at full throttle.
- Tap the spool retainer on ground to advance string. The string advances each time the spool retainer is tapped. Do not hold the spool retainer on the ground.

NOTE: The line trimming cut-off blade on the grass deflector will cut the line to the correct length.

NOTE: If the string is worn too short you may not be able to advance the string by tapping it on the ground. If so, stop the engine, and manually advance the string.

TO ADVANCE THE CUTTING LINE MANUALLY

- Stop the engine.
- Push the spool retainer down while pulling on string(s) to manually advance the string.

CUTTING TIPS

See Figures 16 -17.

- Avoid hot surfaces by always keeping the tool away from your body. (Proper operating position shown in figure 15.)
- Keep the trimmer tilted toward the area being cut; this is the best cutting area.
- The curved shaft trimmer cuts when passing the unit from right to left. The straight shaft trimmer cuts when passing the unit from left to right. This will avoid throwing debris at the operator. Avoid cutting in the dangerous area shown in illustration.
- Use the tip of string to do the cutting; do not force string head into uncut grass.
- Wire and picket fences cause extra string wear, even breakage. Stone and brick walls, curbs, and wood may wear string rapidly.
- Avoid trees and shrubs. Tree bark, wood moldings, siding, and fence posts can easily be damaged by the string.

GRASS DEFLECTOR LINE TRIMMING CUT-OFF BLADE

See Figure 18.

The trimmer is equipped with a line trimming cut-off blade on the grass deflector. For best cutting, advance string until it is trimmed to length by the cut-off blade. Advance the string whenever you hear the engine running faster than

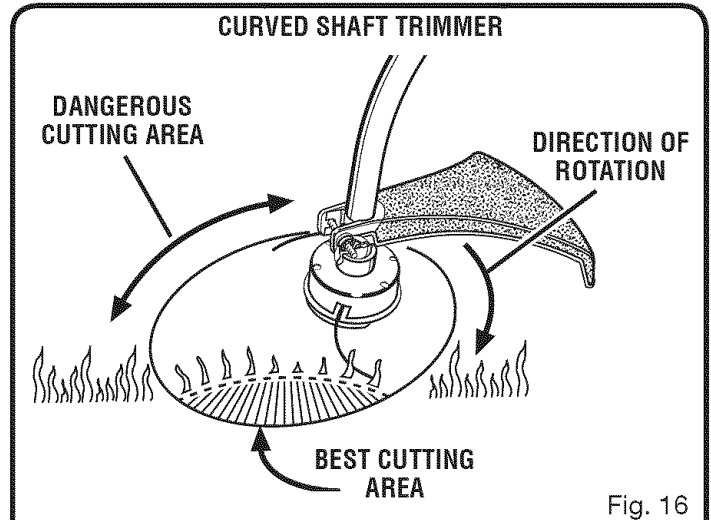

Fig. 16

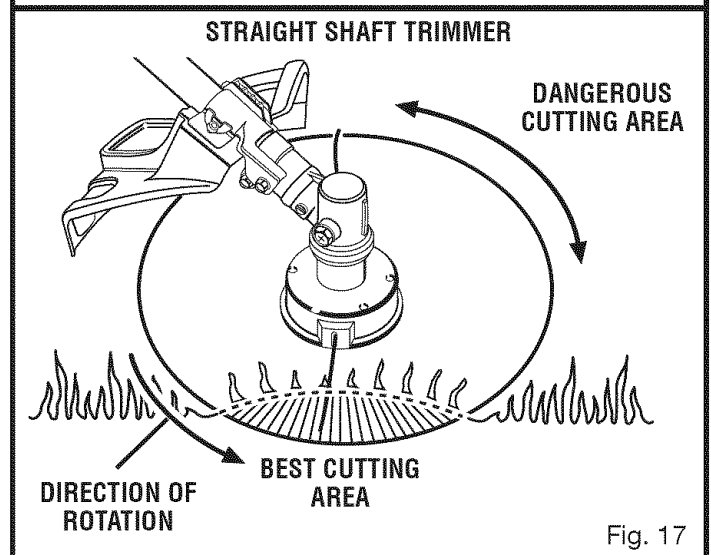

Fig. 17

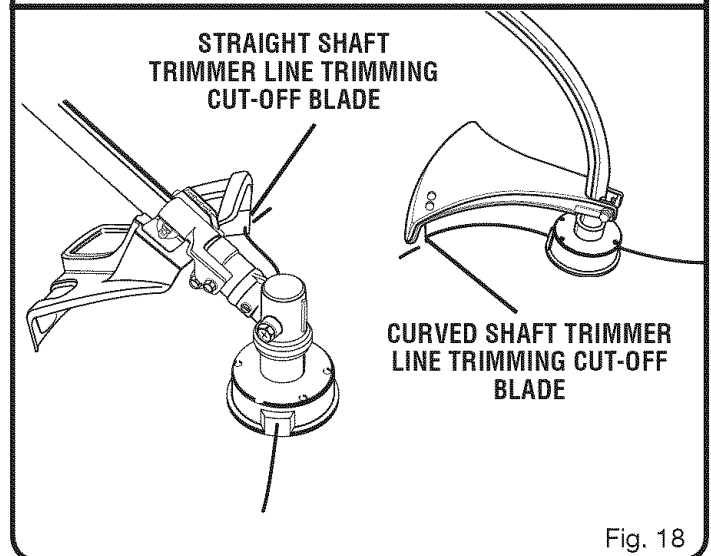

Fig. 18

normal, or when trimming efficiency diminishes. This will maintain best performance and keep the string long enough to advance properly.

OPERATION

OPERATING THE BRUSHCUTTER

See Figures 19 - 20.

Hold the brushcutter with your right hand on the rear handle and your left hand on the "J" Barrier Handle. Keep a firm grip with both hands while in operation. Brushcutter should be held at a comfortable position with the rear handle about hip height. Maintain your grip and balance on both feet. Position yourself so that you will not be drawn off balance by the kickback reaction of the cutting blade.

Adjust the shoulder harness to position the brushcutter at a comfortable operating position and to assure that the shoulder harness will reduce the risk of operator contact with the blade.

BLADE THRUST

Exercise extreme caution when using the blade with this unit. Blade thrust is the reaction that may occur when the spinning blade contacts anything it cannot cut. This contact may cause the blade to stop for an instant, and suddenly "thrust" the unit away from the object that was hit. This reaction can be violent enough to cause the operator to lose control of the unit. Blade thrust can occur without warning if the blade snags, stalls, or binds. This is more likely to occur in areas where it is difficult to see the material being cut. For cutting ease and safety, approach the weeds being cut with the brushcutter from the right to the left. In the event an unexpected object or woody stock is encountered, this practice could minimize the blade thrust reaction.

WARNING:

To avoid burns from hot surfaces, never operate unit with the bottom of the engine above waist level.

TRI-ARC® BLADE

The Tri-Arc® blade is suited only for thicker weeds and pulpy stalks. When the blade becomes dull, it can be turned over to extend the life of the blade. Do not sharpen the Tri-Arc® blade.

Use only Tri-Arc® blade, part number AP04105, available at your local retailer.

CUTTING TECHNIQUE - BLADE

WARNING:

Extreme care must be taken when using blades to ensure safe operation. Read the safety information for safe operation using the blade, refer to **Specific Safety Rules for Brushcutter and Blade Use** earlier in this manual.

- Always hold brushcutter on your right side with both hands when operating. Use a firm grip on both handles.
- Maintain your grip and balance on both feet. Position yourself so that you will not be drawn off balance by the kickback reaction of the cutting blade.

- Inspect and clear the area of any hidden objects such as glass, rocks, concrete, fencing, wire, wood, metal, etc.
- Never use blades near sidewalks, fencing, posts, buildings or other immovable objects.
- Never use a blade after hitting a hard object without first inspecting it for damage. Do not use if any damage is detected.
- The unit is used as a scythe, cutting from the right to the left in a broad sweeping action from side to side.
- Use only the Tri-Arc® blade. To install any other brand blade or cutting head to this brushcutter can result in serious personal injury.

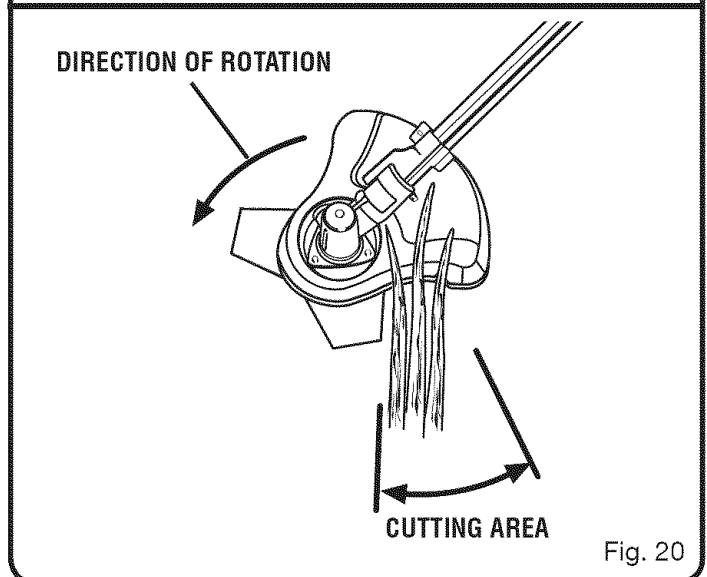
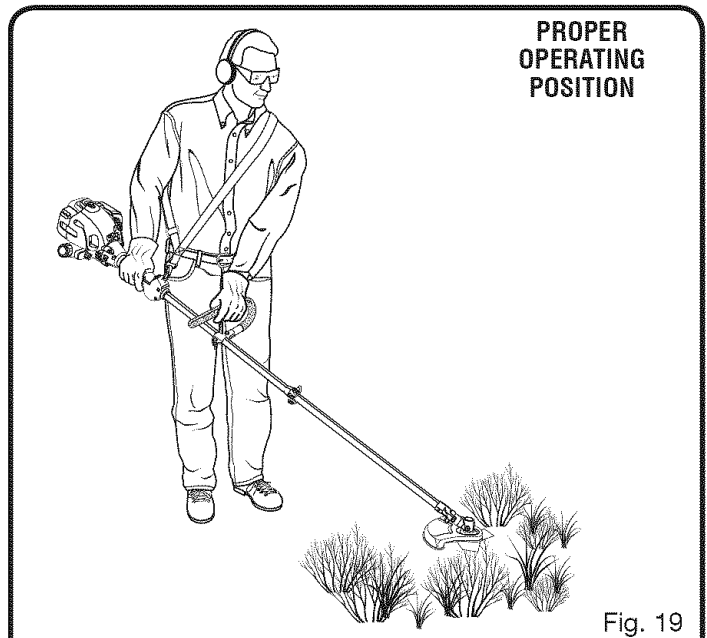

OPERATION

STARTING AND STOPPING

See Figures 21 - 23.

TO START A COLD ENGINE:

DO NOT squeeze the throttle trigger until the engine starts and runs.

- Lay the trimmer on a flat, bare surface.
- **PRIME** - Press the primer bulb 7 times.
- **SET** the start lever to the **START** position.
- **PULL** the rope until the engine starts.
- Wait 6-10 seconds, then squeeze the trigger to run.

NOTE: Squeezing the throttle trigger releases the start lever to the **RUN** position.

TO START A WARM ENGINE:

PULL the rope until the engine starts.

TO STOP THE ENGINE:

Press and hold the switch in the stop "⊘" position until the engine stops.

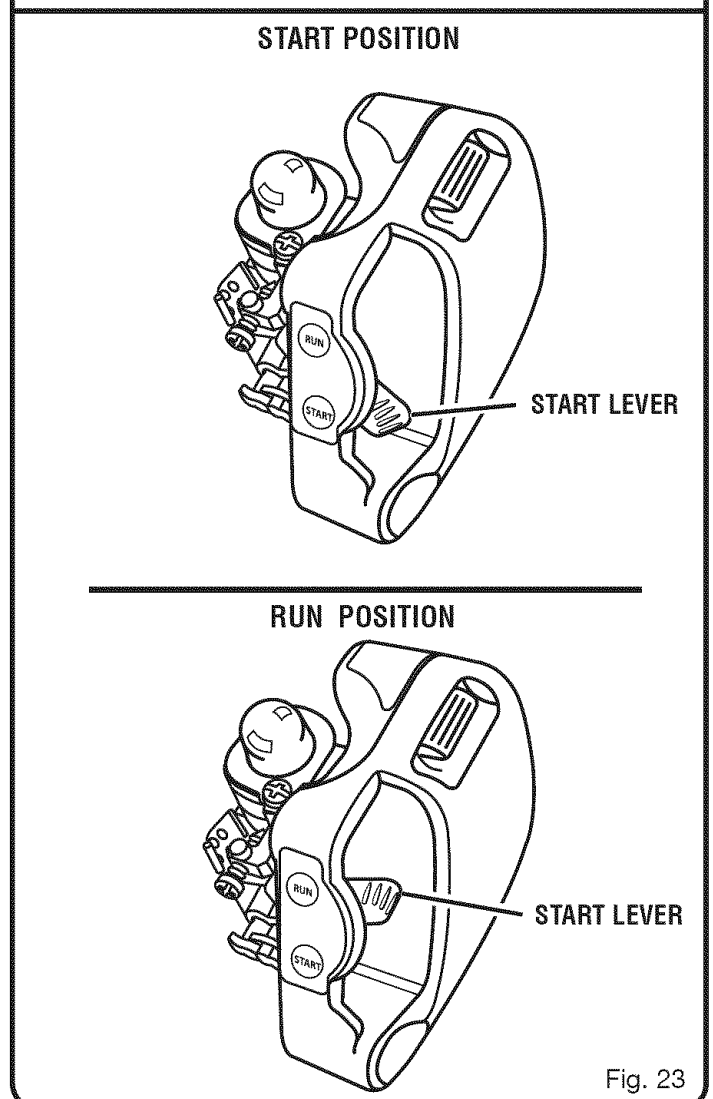
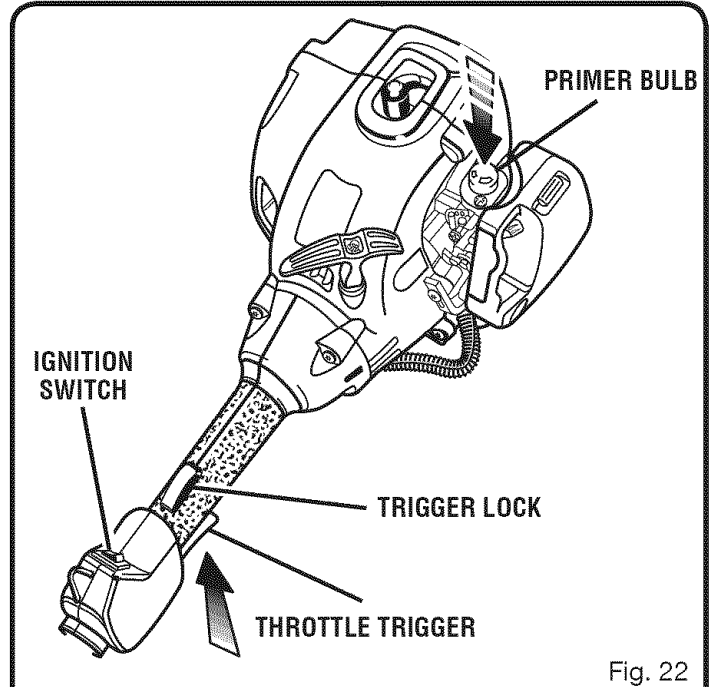
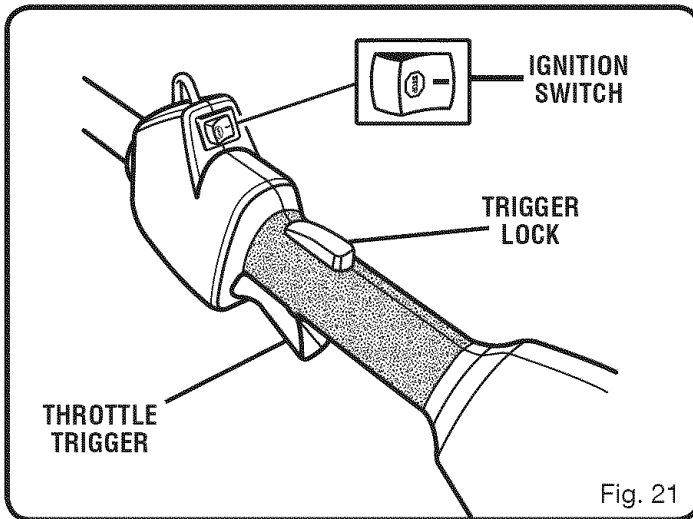

MAINTENANCE

WARNING:

When servicing, use only identical replacement parts. Use of any other parts may create a hazard or cause product damage.

WARNING:

Always wear safety goggles or safety glasses with side shields during tool operation. If operation is dusty, also wear a dust mask.

WARNING:

Before inspecting, cleaning, or servicing the machine, shut off engine, wait for all moving parts to stop, and disconnect spark plug wire and move it away from spark plug. Failure to follow these instructions can result in serious personal injury or property damage.

GENERAL MAINTENANCE

Avoid using solvents when cleaning plastic parts. Most plastics are susceptible to damage from various types of commercial solvents and may be damaged by their use. Use clean cloths to remove dirt, dust, oil, grease, etc.

WARNING:

Do not at any time let brake fluids, gasoline, petroleum-based products, penetrating oils, etc., come in contact with plastic parts. Chemicals can damage, weaken or destroy plastic which may result in serious personal injury.

You can often make adjustments and repairs described here. For other repairs, have the trimmer serviced by an authorized service dealer.

SPOOL REPLACEMENT EZ WIND™ TAP ADVANCE SYSTEM NEW PREWOUND SPOOL

See Figures 24 - 25.

If replacing string only, refer to **String Replacement** later in this manual.

Use only .080 in. diameter trimmer line. Use original manufacturer's replacement string for best performance.

- Stop the engine and disconnect the spark plug wire. Hold the string head and turn the spool retainer clockwise to remove.

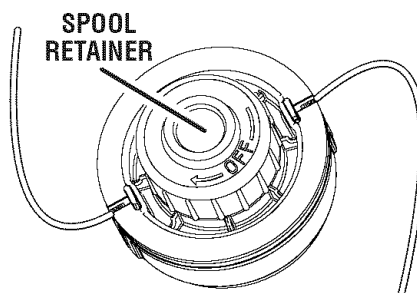

Fig. 24

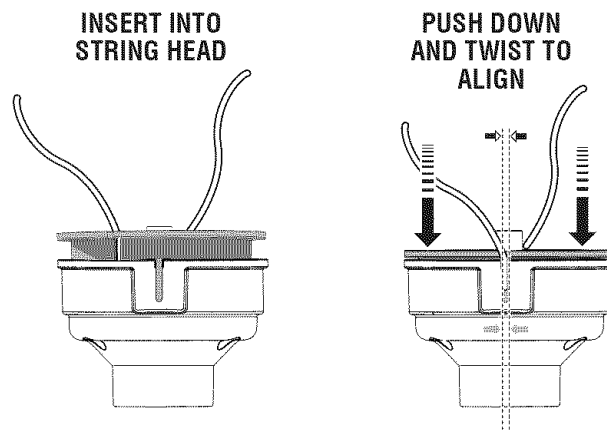

Fig. 25

- Remove the empty spool from the string head. Keep the spring attached to the spool.
- Make sure the two strings are captured in the slots opposite each other on the new spool. Make sure the end of each string is extended approximately 6 in. beyond each slot.
- Align the slot(s) on the spool to the eyelet(s) on the string head housing. Push down and turn the spool in the necessary direction to align the slot(s).
- Make sure the string head and the spool retainer are installed on the drive shaft. Turn the spool retainer counterclockwise to secure.
- Slide strings into the housing eyelets and pull outward to rotate the spool into the cutting position.
- Push the spool retainer down while pulling on string(s) to manually advance the string and to check for proper assembly of the string head.

MAINTENANCE

STRING REPLACEMENT

See Figures 26 - 28.

- Stop the engine and disconnect the spark plug wire. Hold the string head and turn the spool retainer clockwise to remove.
- Remove the spool from the string head.
 - NOTE:** Keep the spring attached to the spool. Remove any old string remaining on the spool.
- Cut one piece of trimmer line 18 ft. long.
- Find the middle of the string section. Loop the string around the hook in the center of the spool. Carefully wind the string in the direction indicated on the top of the spool. Nearing the end of the string, slide one end of the string into each slot of the spool. Do not overfill.
- Replace the spool and the spool retainer. Refer to **Spool Replacement** earlier in this manual.

CLEANING THE EXHAUST PORT AND MUFFLER

NOTE: Depending on the type of fuel used, the type and amount of oil used, and/or your operating conditions, the exhaust port, muffler, and/or spark arrestor screen may become blocked with carbon deposits. If you notice a power loss with your gas powered tool, you may need to remove these deposits to restore performance. We highly recommend that only qualified service technicians perform this service.

SPARK ARRESTOR

The spark arrestor must be cleaned or replaced every 25 hours or yearly to ensure proper performance of your product. Spark arrestors may be in different locations depending on the model purchased. Please contact your nearest service dealer for the location of the spark arrestor for your model.

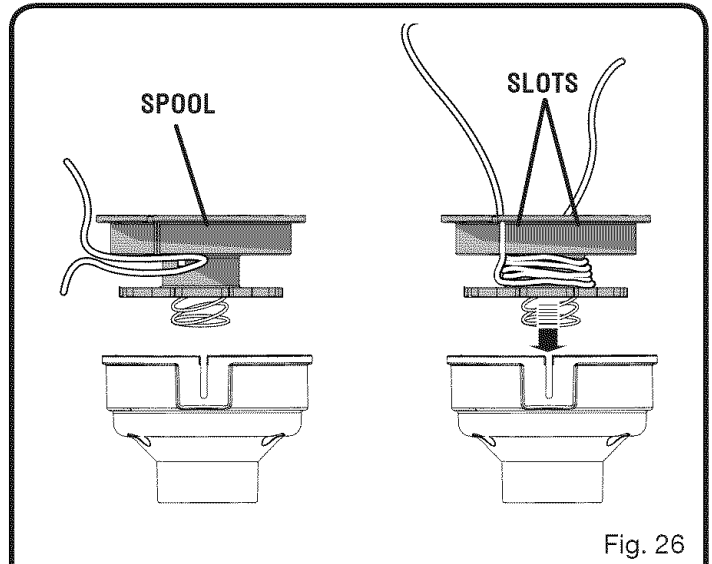

Fig. 26

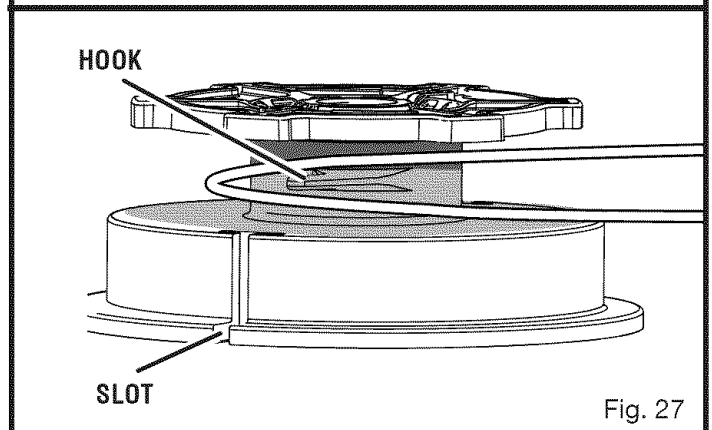

Fig. 27

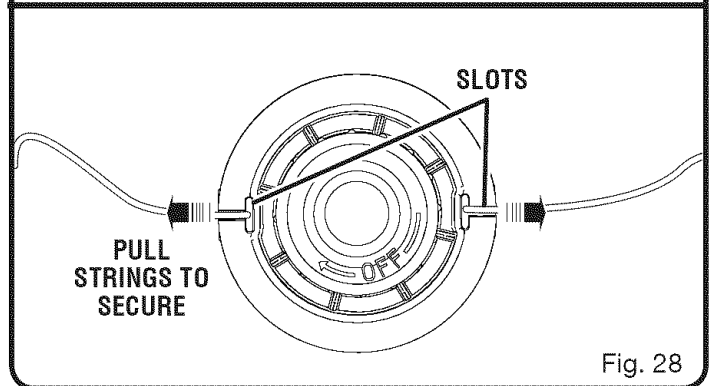

Fig. 28

MAINTENANCE

REPLACING AND CLEANING AIR FILTER

See Figures 29 - 30.

For proper performance and long life, keep air filter clean.

- Remove the air filter cover by pushing down on the latch with your thumb while gently pulling on the cover.
- Remove the air filter and clean it in warm soapy water. Rinse and let dry completely.
- Reinstall the air filter.
- Replace the air filter cover by inserting the tabs on the bottom of the cover into the slots on the air filter base; push the cover up until it latches securely in place.

NOTE: For best performance, replace annually.

FUEL CAP

WARNING:

A leaking fuel cap is a fire hazard and must be replaced immediately.

The fuel cap contains a non-serviceable filter and a check valve. A clogged fuel filter will cause poor engine performance. If performance improves when the fuel cap is loosened, check valve may be faulty or filter clogged. Replace fuel cap if required.

SPARK PLUG REPLACEMENT

This engine uses a Champion RCJ-6Y or NGK BPMR7A spark plug with .025 in. electrode gap. Use an exact replacement and replace annually.

STORING THE PRODUCT

- Clean all foreign material from the product. Store idle unit indoors in a dry, well-ventilated area that is inaccessible to children. Keep away from corrosive agents such as garden chemicals and de-icing salts.
- Abide by all ISO and local regulations for the safe storage and handling of gasoline.

When storing 1 month or longer:

- Drain all fuel from tank into a container approved for gasoline. Run engine until it stops.

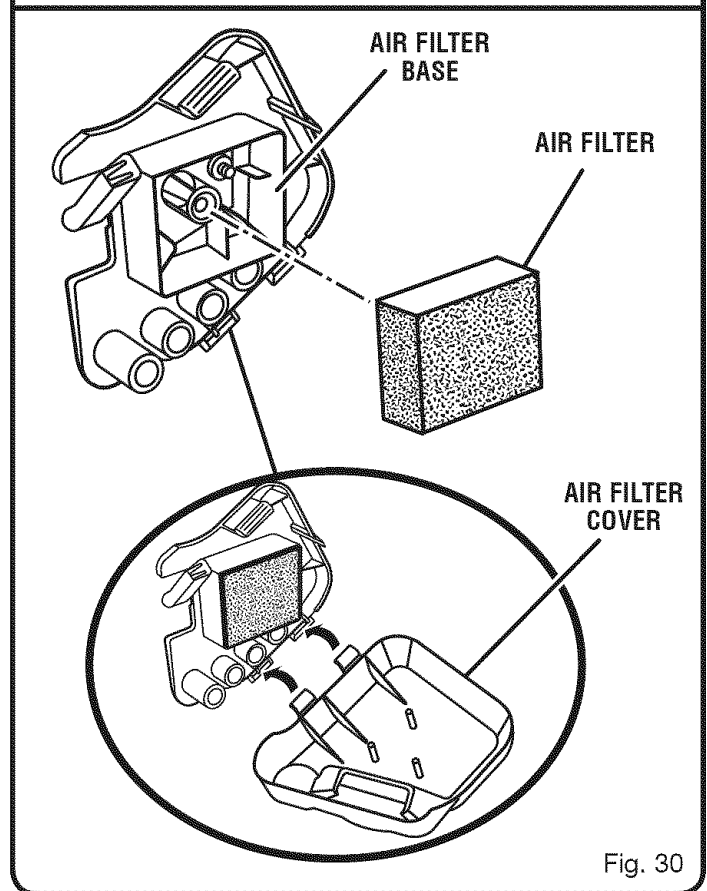
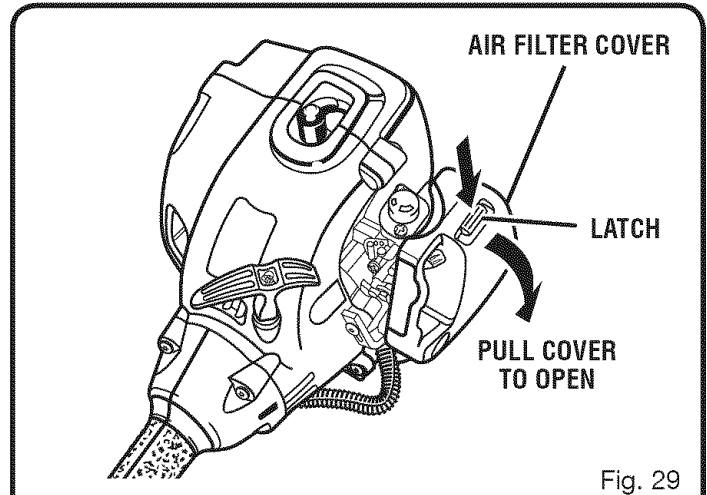

TROUBLESHOOTING

IF THESE SOLUTIONS DO NOT SOLVE THE PROBLEM CONTACT YOUR AUTHORIZED SERVICE DEALER.

PROBLEM	POSSIBLE CAUSE	SOLUTION
Engine will not start	<ol style="list-style-type: none"> 1. No spark. 2. No fuel. 3. Engine is flooded. 	<ol style="list-style-type: none"> 1. Check spark. Remove spark plug. Reattach the spark plug cap and lay spark plug on metal cylinder. Pull the rope and watch for spark at spark plug tip. If there is no spark, repeat test with a new spark plug. 2. Push primer bulb until bulb is full of fuel. If bulb does not fill, primary fuel delivery system is blocked. Contact a service dealer. If primer bulb fills, engine may be flooded, proceed to next item. 3. Set the start lever to the START position. Squeeze the trigger and pull the rope repeatedly until the engine starts and runs. NOTE: Depending on the severity of the flooding, this may require numerous pulls of the rope. See <i>Figure 23</i>.
Engine does not reach full speed and emits excessive smoke	<ol style="list-style-type: none"> 1. Incorrect oil/fuel mixture. 2. Air filter is dirty. 3. Spark arrestor screen is dirty. 4. Spark plug fouled. 	<ol style="list-style-type: none"> 1. Use fresh fuel and the correct 2-cycle oil mix. (50:1). 2. Clean air filter. Refer to Replacing and Cleaning Air Filter earlier in this manual. 3. Contact a servicing dealer. 4. Clean or replace spark plug. Reset spark plug gap. Refer to Spark Plug Replacement earlier in this manual.
Engine starts, runs, and accelerates but will not idle	<ol style="list-style-type: none"> 1. Idle speed screw on carburetor needs adjustment. 	<ol style="list-style-type: none"> 1. Turn idle speed screw clockwise to increase idle speed. See <i>Figure 31</i>.
String will not advance	<ol style="list-style-type: none"> 1. String is welded to itself. 2. Not enough string on spool. 3. String is worn too short. 4. String is tangled on spool. 5. Engine speed is too slow. 	<ol style="list-style-type: none"> 1. Lubricate string with silicone spray. 2. Install more string. Refer to String Replacement earlier in this manual. 3. Pull strings while alternately pressing down on and releasing spool retainer. 4. Remove string from spool and rewind. Refer to String Replacement earlier in this manual. 5. Advance string at full throttle.

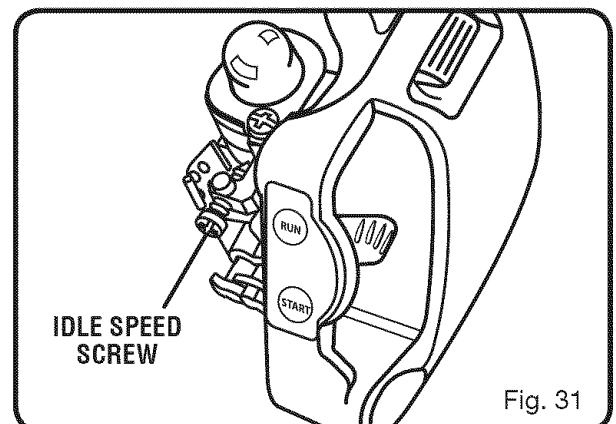

Fig. 31

TROUBLESHOOTING

IF THESE SOLUTIONS DO NOT SOLVE THE PROBLEM CONTACT YOUR AUTHORIZED SERVICE DEALER.

PROBLEM	POSSIBLE CAUSE	SOLUTION
Spool retainer hard to turn	1. Screw threads are dirty or damaged.	1. Clean threads and lubricate with grease - if no improvement, replace the spool retainer.
Grass wraps around driveshaft housing and string head	1. Cutting tall grass at ground level. 2. Operating trimmer at part throttle.	1. Cut tall grass from the top down to prevent wrapping. 2. Operate trimmer at full throttle.

WARRANTY

THIS PRODUCT WAS MANUFACTURED WITH A CATALYST MUFFLER

Congratulations! You have made an investment toward protecting the environment. In order to maintain this product's original emission level, please refer to the maintenance section below.

EMISSIONS MAINTENANCE SCHEDULE AND WARRANTED PARTS LIST

Emissions Parts	Inspect Before Each Use	Clean Every 5 Hours	Replace Every 25 Hours or Yearly	Clean Every 25 Hours or Yearly	Replace Every 50 Hours
CATALYTIC MUFFLER ASSEMBLY					X
AIR FILTER ASSY					
includes:					
Filter		X			X
SPARK SCREEN					X
CARBURETOR ASSY					
includes:					
Heat Dam					
Gaskets					
FUEL TANK ASSY					
includes:					
Fuel Lines			X		
Fuel Cap			X		
Fuel Filter					
IGNITION ASSY					
includes:					
Spark Plug					X

ALL EMISSIONS-RELATED PARTS ARE WARRANTED FOR TWO YEARS OR FOR THE PERIOD OF TIME PRIOR TO THE PARTS FIRST SCHEDULED REPLACEMENT WHICHEVER COMES FIRST.



CALL US FIRST

For any questions about operating or maintaining your product,
call the Ryobi® Help Line!

Your product has been fully tested prior to shipment to ensure
your complete satisfaction.

WARRANTY

LIMITED WARRANTY STATEMENT

Techtronic Industries North America, Inc., warrants to the original retail purchaser that this RYOBI® brand outdoor product is free from defect in material and workmanship and agrees to repair or replace, at Techtronic Industries North America, Inc.'s, discretion, any defective product free of charge within these time periods from the date of purchase.

- Two years if the product is used for personal, family or household use;
- 90 days, if used for any other purpose, such as commercial or rental.

This warranty extends to the original retail purchaser only and commences on the date of the original retail purchase.

Any part of this product found in the reasonable judgment of Techtronic Industries North America, Inc. to be defective in material or workmanship will be repaired or replaced without charge for parts and labor by an authorized service center for RYOBI® brand outdoor products (Authorized Ryobi Service Center).

The product, including any defective part, must be returned to an authorized Ryobi service center within the warranty period. The expense of delivering the product to the service center for warranty work and the expense of returning it back to the owner after repair or replacement will be paid by the owner. Techtronic Industries North America, Inc.'s, responsibility in respect to claims is limited to making the required repairs or replacements and no claim of breach of warranty shall be cause for cancellation or rescission of the contract of sale of any RYOBI® brand outdoor product. Proof of purchase will be required by the dealer to substantiate any warranty claim. All warranty work must be performed by an authorized service dealer.

This warranty is limited to ninety (90) days from the date of original retail purchase for any RYOBI® brand outdoor product that is used for rental or commercial purposes, or any other income-producing purpose.

This warranty does not cover any product that has been subject to misuse, neglect, negligence, or accident, or that has been operated in any way contrary to the operating instructions as specified in this operator's manual. This warranty does not apply to any damage to the product that is the result of improper maintenance or to any product that has been altered or modified. The warranty does not extend to repairs made necessary by normal wear or by the use of parts or accessories which are either incompatible with the RYOBI® brand outdoor product or adversely affect its operation, performance, or durability. In addition, this warranty does not cover:

- A. Tune-ups – Spark Plugs, Carburetor, Carburetor Adjustments, Ignition, Filters
- B. Wear items – Bump Knobs, Outer Spools, Cutting Lines, Inner Reels, Starter Pulleys, Starter Ropes, Drive Belts, Tines, Felt Washers, Hitch Pins, Mulching Blades, Blower Fans, Blower and Vacuum Tubes, Vacuum Bag and Straps, Guide Bars, Saw Chains

Techtronic Industries North America, Inc., reserves the right to change or improve the design of any RYOBI® brand outdoor product without assuming any obligation to modify any product previously manufactured.

ALL IMPLIED WARRANTIES ARE LIMITED IN DURATION TO THE STATED WARRANTY PERIOD. ACCORDINGLY, ANY SUCH IMPLIED WARRANTIES INCLUDING MERCHANTABILITY, FITNESS FOR A PARTICULAR PURPOSE, OR OTHERWISE, ARE DISCLAIMED IN THEIR ENTIRETY AFTER THE EXPIRATION OF THE APPROPRIATE TWO-YEAR, ONE-YEAR, OR NINETY-DAY WARRANTY PERIOD. TECHTRONIC INDUSTRIES NORTH AMERICA, INC.'S, OBLIGATION UNDER THIS WARRANTY IS STRICTLY AND EXCLUSIVELY LIMITED TO THE REPAIR OR REPLACEMENT OF DEFECTIVE PARTS AND TECHTRONIC INDUSTRIES NORTH AMERICA, INC., DOES NOT ASSUME OR AUTHORIZE ANYONE TO ASSUME FOR THEM ANY OTHER OBLIGATION. SOME STATES DO NOT ALLOW LIMITATIONS ON HOW LONG AN IMPLIED WARRANTY LASTS, SO THE ABOVE LIMITATION MAY NOT APPLY TO YOU. TECHTRONIC INDUSTRIES NORTH AMERICA, INC., ASSUMES NO RESPONSIBILITY FOR INCIDENTAL, CONSEQUENTIAL, OR OTHER DAMAGES INCLUDING, BUT NOT LIMITED TO, EXPENSE OF RETURNING THE PRODUCT TO AN AUTHORIZED RYOBI SERVICE CENTER AND EXPENSE OF DELIVERING IT BACK TO THE OWNER, MECHANIC'S TRAVEL TIME, TELEPHONE OR TELEGRAM CHARGES, RENTAL OF A LIKE PRODUCT DURING THE TIME WARRANTY SERVICE IS BEING PERFORMED, TRAVEL, LOSS OR DAMAGE TO PERSONAL PROPERTY, LOSS OF REVENUE, LOSS OF USE OF THE PRODUCT, LOSS OF TIME, OR INCONVENIENCE. SOME STATES DO NOT ALLOW THE EXCLUSION OR LIMITATION OF INCIDENTAL OR CONSEQUENTIAL DAMAGES, SO THE ABOVE LIMITATION OR EXCLUSION MAY NOT APPLY TO YOU.

This warranty gives you specific legal rights, and you may also have other rights which vary from state to state.

This warranty applies to all RYOBI® brand outdoor products manufactured by or for Techtronic Industries North America, Inc., and sold in the United States and Canada.

To locate your nearest Authorized Ryobi Service Center, dial 1-800-860-4050.

WARRANTY

THE FOLLOWING CALIFORNIA AIR RESOURCES BOARD (CARB) STATEMENT ONLY APPLIES TO MODEL NUMBERS REQUIRED TO MEET THE CARB REQUIREMENTS.

TECHTRONIC INDUSTRIES NORTH AMERICA, INC., LIMITED WARRANTY STATEMENT FOR FEDERAL AND CALIFORNIA EMISSION CONTROL SYSTEMS NON-ROAD AND SMALL OFF-ROAD ENGINES

YOUR WARRANTY RIGHTS AND OBLIGATIONS

The U.S. Environmental Protection Agency (EPA), the California Air Resources Board (CARB), and Techtronic Industries North America, Inc., are pleased to explain the Emissions Control System Warranty on your 2007 model year non-road or small off-road engine. In California, new equipment that uses small off-road engines must be designed, built, and equipped to meet the state's stringent anti-smog standards. In other states, new 2000 and later model year non-road engines must be designed, built, and equipped at the time of sale to meet the U.S. EPA regulations for small non-road engines. The non-road engine must be free from defects in materials and workmanship which cause it to fail to conform with U.S. EPA standards for the first two years of engine use from the date of sale to the ultimate purchaser. Techtronic Industries North America, Inc., must warrant the emission control system on your non-road or small off-road engine for the period of time listed above provided there has been no abuse, neglect, or improper maintenance of your non-road or small off-road engine.

Your emission control system may include parts such as the carburetor or fuel injection system, the ignition system, catalytic converters, fuel tanks, valves, filters, clamps, connectors, and other associated components. Also included may be hoses, belts and connectors, and other emission-related assemblies.

Where a warrantable condition exists, Techtronic Industries North America, Inc., will repair your non-road or small off-road engine at no cost to you, including diagnosis, parts, and labor performed at an authorized service center for RYOBI® brand outdoor products.

MANUFACTURER'S WARRANTY COVERAGE:

This product's emissions control system is warranted for two years. If any emission-related part on your engine is defective, the part will be repaired or replaced by Techtronic Industries North America, Inc., free of charge.

OWNER'S WARRANTY RESPONSIBILITIES

(a) As the non-road or small off-road engine owner, you are responsible for the performance of the required maintenance listed in your operator's manual. Techtronic Industries North America, Inc., recommends that you retain all receipts covering maintenance on your non-road or small off-road engine, but Techtronic Industries North America, Inc., cannot deny warranty solely for the lack of receipts or for your failure to ensure the performance of all scheduled maintenance. Any replacement part or service that is equivalent in performance and durability may be used in non-warranty maintenance or repairs, and shall not reduce the warranty obligations of Techtronic Industries North America, Inc.

(b) As the non-road or small off-road engine owner, you should be aware, however, that Techtronic Industries North America, Inc., may deny you warranty coverage if your non-road or small off-road engine or a part has failed due to abuse, neglect, improper maintenance, or unapproved modifications.

(c) You are responsible for presenting your non-road or small off-road engine to an authorized service dealer as soon as a problem exists. The warranty repairs should be completed in a reasonable amount of time, not to exceed 30 days.

If you have any questions regarding your warranty rights and responsibilities, you should contact a Techtronic Industries North America, Inc., Customer Representative at 1-800-860-4050.

DEFECT WARRANTY COVERAGE REQUIREMENTS:

(a) The warranty period begins on the date the engine or equipment is delivered to an ultimate purchaser.

(b) General Emissions Warranty Coverage. Techtronic Industries North America, Inc., warrants to the ultimate purchaser and each subsequent purchaser that your non-road or small off-road engine is designed, built, and equipped at the time of sale to conform with all applicable regulations adopted by the California Air Resources Board or the United States Environmental Protection Agency; and that it is free from defects in materials and workmanship which cause the engine to fail to conform with applicable regulations for a period of two years from the date the non-road or small off-road engine is purchased by the initial purchaser.

(c) The warranty on emissions-related parts will be interpreted as follows: Any warranted part that is not scheduled for replacement as required in the Emissions Maintenance Schedule and Warranty Parts List set forth below is warranted for two years. If any such part (including any part that is scheduled only for regular inspection) fails during the period of warranty coverage, it will be repaired or replaced at any RYOBI® Authorized Service Center at no charge. Any such part repaired or replaced under warranty will be warranted for the remaining warranty period. A statement to the effect of "repair or replace as necessary" would not reduce the period of warranty coverage. Any warranted part that is scheduled for replacement as required maintenance in the Emissions Maintenance Schedule and Warranty Parts List is warranted for the period of time prior to the first scheduled replacement point for that part. Any such part repaired or replaced under warranty is warranted for the remainder of the period prior to the first scheduled replacement point, and will be repaired or replaced at any RYOBI® Authorized Service Center for no charge until that replacement point is reached.

Techtronic Industries North America, Inc., shall remedy warranty defects at any authorized RYOBI® Authorized Service Center, including any distribution center that may be franchised to service the subject engines. Any diagnostic work done at a RYOBI® Authorized Service Center shall be free of charge to the owner if such work determines that a warranted part is defective. Any manufacturer-approved or equivalent replacement part may be used for any warranty maintenance or repairs on emission-related parts, and must be provided free of charge to the owner if the part is still under warranty. Techtronic Industries North America, Inc., is liable for damages to other engine components caused by the failure of a warranted part still under warranty.

Add-on or modified parts that are not exempted by the California Air Resource Board may not be used. The use of any non-exempted add-on or modified parts will be grounds for disallowing a warranty claim. Techtronic Industries North America, Inc., will not be liable to warrant failures of warranted parts caused by the use of a non-exempted add-on or modified part.

The California Air Resources Board's Emission Warranty Parts List specifically defines the emission-related warranted parts. (EPA's regulations do not include a parts list, but the EPA considers emission-related warranted parts to include all the parts listed below.) Techtronic Industries North America, Inc., will provide any documents that describe its warranty procedures or policies within five days upon request by the California Air Resources Board.

EMISSIONS PARTS LIST

Emissions parts vary from product to product. Your emissions control system warranty applies to any of the following components that may be included on your product:

- (1) Fuel Metering System
 - (i) Carburetor and internal parts (and/or pressure regulator or fuel injection system).
 - (ii) Air/fuel ratio feedback and control system.
 - (iii) Cold start enrichment system.
 - (iv) Fuel Tank.
- (2) Air Induction System
 - (i) Controlled hot air intake system.
 - (ii) Intake manifold.
 - (iii) Air filter.
- (3) Ignition System
 - (i) Spark Plugs.
 - (ii) Magneto or electronic ignition system.
 - (iii) Spark advance/retard system.
- (4) Exhaust Gas Recirculation (EGR) System
 - (i) EGR valve body and carburetor spacer, if applicable.
 - (ii) EGR rate feedback and control system.
- (5) Air Injection System
 - (i) Air pump or pulse valve.
 - (ii) Valves affecting distribution of flow.
 - (iii) Distribution manifold.
- (6) Catalyst or Thermal Reactor System
 - (i) Catalytic converter.
 - (ii) Thermal reactor.
 - (iii) Exhaust manifold.
- (7) Particulate Controls
 - (i) Traps, filters, precipitators, and any other device used to capture particulate emissions.
- (8) Miscellaneous Items Used in Above Systems
 - (i) Electronic controls.
 - (ii) Vacuum, temperature, and time sensitive valves and switches.
 - (iii) Hoses, belts, connectors, and assemblies.

Techtronic Industries North America, Inc., will furnish with each new engine written instructions for its maintenance and use by the owner.

The Emissions Compliance Period referred to on the Emissions Compliance label indicates the number of operating hours for which the engine has been shown to meet Federal emission requirements. Category C=50 hours, B=125 hours, and A=300 hours.



OPERATOR'S MANUAL

30cc String Trimmers and Brushcutters

CS30 – RY30522/RY30923

SS30 – RY30542/RY30943

BC30 – RY30562/RY30963

WARNING:

The engine exhaust from this product contains chemicals known to the State of California to cause cancer, birth defects or other reproductive harm.

CALIFORNIA PROPOSITION 65

• PARTS AND SERVICE

Prior to requesting service or purchasing replacement parts, please obtain your model and serial number from the product data plate.

- MODEL NUMBER _____
- SERIAL NUMBER _____

• HOW TO OBTAIN REPLACEMENT PARTS:

Replacement parts can be purchased online at www.ryobitools.com or by calling 1-800-860-4050. Replacement parts can also be obtained at one of our Authorized Service Centers.

• HOW TO LOCATE AN AUTHORIZED SERVICE CENTER:

Authorized Service Centers can be located online at www.ryobitools.com or by calling 1-800-860-4050.

• HOW TO OBTAIN CUSTOMER OR TECHNICAL SUPPORT:

To obtain Customer or Technical Support please contact us at 1-800-860-4050.

Ryobi® is a registered trademark of Ryobi Limited used under license.

TECHTRONIC INDUSTRIES NORTH AMERICA, INC.

1428 Pearman Dairy Road, Anderson, SC 29625

Phone 1-800-860-4050

www.ryobitools.com