

RCA

u
s
e
r
m
a
n
u
a
l

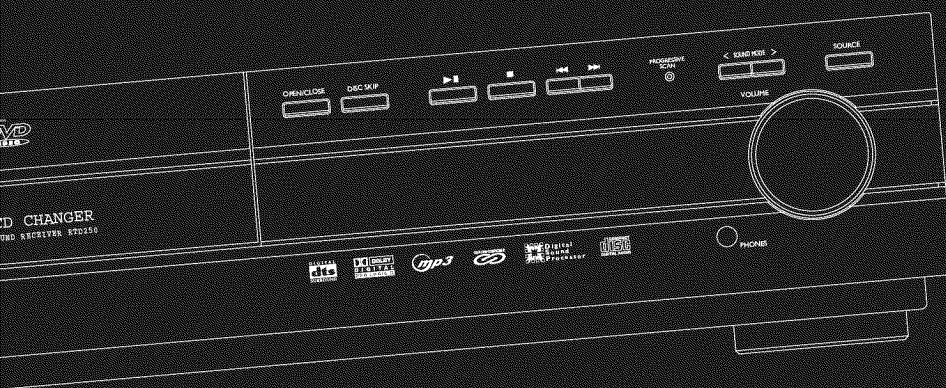

RTD250

It is important to read this instruction book prior to using your new product for the first time.
Es importante leer este manual antes de usar por vez primera su equipo.

FCC Information

This device complies with Part 15 of the FCC Rules. Operation is subject to the following two conditions: (1) This device may not cause harmful interference, and (2) this device must accept any interference received, including interference that may cause undesired operation.

This equipment has been tested and found to comply with the limits for a Class B digital device, pursuant to Part 15 of the FCC Rules. These limits are designed to provide reasonable protection against harmful interference in a residential installation. This equipment generates, uses and radiates radio frequency energy and, if not installed and used in accordance with the instruction, may cause harmful interference to radio communications. However, there is no guarantee that interference will not occur in a particular installation.

In accordance with FCC requirements, changes or modifications not expressly approved by Thomson Inc. could void the user's authority to operate this product.

This device generates and uses radio frequency (RF) energy, and if not installed and used properly, this equipment may cause interference to radio and television reception.

If this equipment does cause interference to radio or television reception (which you can determine by unplugging the unit), try to correct the interference by one or more of the following measures:

- Re-orient the receiving antenna (that is, the antenna for the radio or television that is "receiving" the interference).
- Move the unit away from the equipment that is receiving interference.
- Plug the unit into a different wall outlet so that the unit and the equipment receiving interference are on different branch circuits.

If these measures do not eliminate the interference, please consult your dealer or an experienced radio/television technician for additional suggestions.

Also, the Federal Communications Commission has prepared a helpful booklet, "How To Identify and Resolve Radio TV Interference Problems." This booklet is available from the U.S. Government Printing Office, Washington, DC 20402. Please specify stock number 004-000-00345-4 when ordering copies.

This product complies with DHHS Rules 21 CFR Subchapter J. Applicable at the date of manufacture.

For Your Safety

The AC power plug is polarized (one blade is wider than the other) and only fits into AC power outlets one way. If the plug won't go into the outlet completely, turn the plug over and try to insert it the other way. If it still won't fit, contact a qualified electrician to change the outlet, or use a different one. Do not attempt to bypass this safety feature.

For Your Records

In the event that service should be required, you may need both the model number and the serial number. In the space below, record the date and place of purchase, and the serial number:

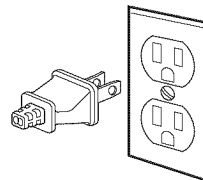

Model No.
Remote Control No. RCR311AAM1
Date of Purchase
Place of Purchase
Serial No.

Service Information

This product should be serviced only by those specially trained in appropriate servicing techniques. For instructions on how to obtain service, refer to the warranty included in this Guide.

Product

Dolby Digital 5DVD Audio video receiver
Brand: RCA
Model: RTD250

Electrical current consumption



120V
60Hz
180 Watts

IMPORTER

Comercializadora Thomson de Mexico, S.A. de C.V.
Miguel de Cervantes Saavedra No. 57
Col. Ampliación Granada
C.P. 11529 Mexico D.F.
Telefono: (55)25 81 53 20
RFC: CTM-980723-K55

This Class B digital apparatus complies with Canadian ICES-003.

Cet appareil numérique de la class B est conforme à la norme du NMB-003 du Canada

 THE LIGHTNING FLASH AND ARROW-HEAD WITHIN THE TRIANGLE IS A WARNING SIGN ALERTING YOU OF "DANGEROUS VOLTAGE" INSIDE THE PRODUCT.	CAUTION RISK OF ELECTRIC SHOCK DO NOT OPEN CAUTION: TO REDUCE THE RISK OF ELECTRIC SHOCK, DO NOT REMOVE COVER (OR BACK). NO USER-SERVICEABLE PARTS INSIDE. REFER SERVICING TO QUALIFIED SERVICE PERSONNEL.	 THE EXCLAMATION POINT WITHIN THE TRIANGLE IS A WARNING SIGN ALERTING YOU OF IMPORTANT INSTRUCTIONS ACCOMPANYING THE PRODUCT.
SEE MARKING ON BOTTOM / BACK OF PRODUCT		

WARNING: TO PREVENT FIRE OR ELECTRICAL SHOCK HAZARD, DO NOT EXPOSE THIS PRODUCT TO RAIN OR MOISTURE.

MusicMatch™ Software

RCA is among the first Consumer Electronics companies to have adopted the MP3 format, starting with the release of its mp3 player, Lyra, into the market. (www.rca.com and www.lyrazone.com). RCA is proud of its initial success and has developed the competencies to enlarge its offering to other products like Discman and this System. RCA thanks you for your purchase of this System which aims at giving you tremendous pleasure while listening to your favorite music. In addition to this great System, RCA is proud to offer you the Music Match CD-ROM, which will assist you in managing your mp3 music library!

The MusicMatch Jukebox

This music management software, to be installed on your PC, allows you to compress music files recorded from you audio CDs into mp3 format and stores them on your PC.

- It makes the search and download of Internet music easier,
- It allows for the management of compressed music and the creation of your own playlist,
- The Jukebox is a true audio player installed on your PC,
- It gives access to thousands of net radios available on the web today.

You can download music files encoded in mp3 from several Internet sites like www.mp3.com.

Playing mp3

- Use .mp3 as the extension when converting audio files into mp3 for saving onto CD-R(W) or CD-ROM, e.g. Rocky08.mp3. Do not use any other extension e.g. .doc, .pdf.
- Do not use the .mp3 extension for other text or non-audio data files as this may result in serious malfunction and harmful noise interference.

Table of Content

EN

FCC Information

MusicMatch Software

Getting Started

Unpacking the DVD Receiver	2
Unpacking the Speakers	2
Inserting Batteries into Remote Control	3
Set Up and Maintenance of the Receiver	3
Protect your Components from Overheating	3
Disc Information	3
Connecting to Audio-Visual Components	4
Digital Connection	5
Connecting Antennas	5
Connecting the Speakers	6
Connecting the Subwoofer	6
Positioning your Speaker	7
Front Speaker Placement	7
Preferred Surround Placement	8
Advanced Surround Setting	8
Test Tone / Channel Balance	9
Using Headphones	9
Factory Setting	9

Operating your Receiver

Receiver Controls	10
Remote Control	11
Display	12
Switching On/Off	13
Selection of Audio/Video Source	13
Using the Remote to Control Additional Components	14

Advanced Sound Control

Sound Enhancement Systems	15
Fine Setting of Components	16
Fine Setting of the Speakers	17
Advanced Setting	17

DVD Player

Basic Playback Features	19
Quick Search	19
Freeze Frame and Frame Advance	19
Slow Motion Playback (DVD only)	20
Progressive Scan	20
On-Screen Banner Display	20
Setup Menu	25

CD / mp3 Player

mp3 Recommendations	30
Loading and Playing an Audio CD	30
On-Screen Banner Display for CD Playback	32
On-Screen Display for mp3 playback	35-36

JPEG CD

On-Screen Display for JPEG CD	37
-------------------------------	----

Radio

Operating the Radio	38-39
---------------------	-------

Troubleshooting Tips **40-41**

Care and Maintenance **42**

Remote Codes

TV Codes	43-44
----------	-------

Language Code **45**

Limited Warranty

Getting Started

Unpacking the DVD Receiver

You should receive the following items:

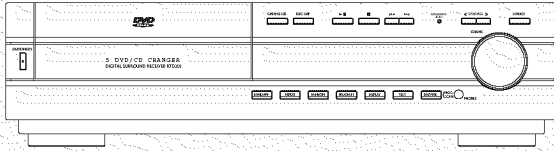

One DVD receiver unit

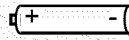

One pair of "AAA" batteries

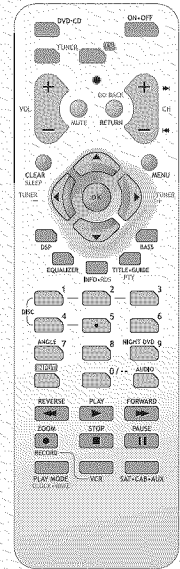

One RCA Universal Remote Control (RCR311AAM1)



One Pig-Tail antenna wire

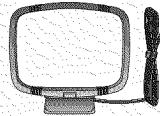

One external AM loop antenna

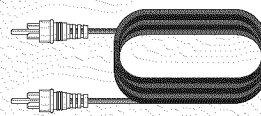

one video cable (single wire) with yellow connectors;

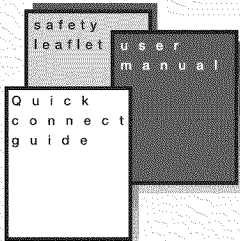

- one instruction book;
- one safety leaflet;
- one Quick Connection Guide

Unpacking The Speakers

- one set of speakers including 1 set of left and right front speakers, 1 centre speaker, 1 subwoofer and 1 set of left and right rear speakers.

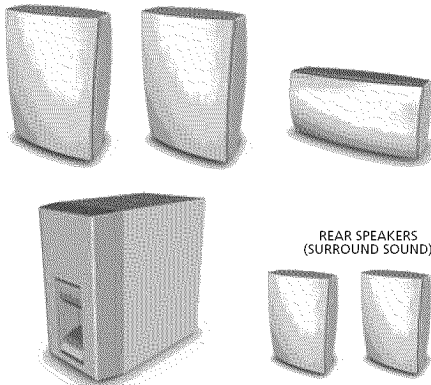

1 X green/black wire for center speaker



1 X red/black wire for front right speaker



1 X white/black wire for front left speaker



1 X purple/black wire for subwoofer



1 X blue/black wire for rear left speaker



1 X gray/black wire for rear right speaker

Inserting Batteries into Remote Control

Insert two AAA batteries according to the + and - signs on the battery compartment. To use the remote control, point it directly at your receiver.

Set up and Maintenance of the Receiver

IMPORTANT NOTE



• Provide spaces for sufficient ventilation as indicated below. If the space is insufficient, the unit may overheat resulting in malfunction and shorter life time.

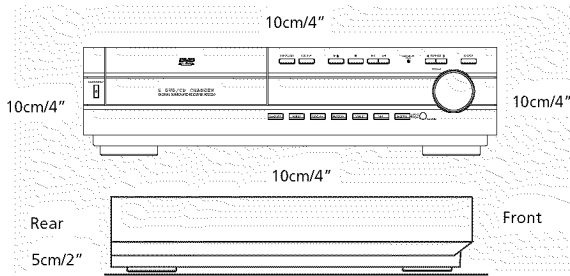

- Do not connect to the AC power cords until all connections are completed.
- Do not use your set immediately after transferring it from a cold place to a warm place: there is risk of condensation.
- Do not expose your set to water and excessively high temperatures.
- After having disconnected your set, clean the case with a soft cloth, or with a slightly damp leather chamois. Never use strong solvents.

Disc handling precaution:

- Do not touch the recorded surface.
- Do not use record cleaning sprays, solvent or anti-static liquid.
- If the disc is dirty, clean it with a damp cloth and wipe from the center out. Wipe in straight line and not in circular motion.
- Do not attach stickers, label on the disc.
- Store the disc in its case after playing.



Protect your Components from Overheating

- Do not block ventilation holes in any component. Arrange the components so that air can circulate freely.
- Do not stack components directly on top of each other.
- Allow adequate ventilation when placing your components in a stand.
- Place the receiver near the top shelf of the stand so heated air rising from it will not affect other components.

Disc Information

About CDR, CDRW, Audio mp3, Compact Disk Audio (CDA), DVD Video, DVD Audio

This model is compatible to play CDR, CDRW, Audio mp3, Compact Disk Audio (CDA), Video Compact Disk (VCD) and DVD Audio, JPEG pictures. While your disc player is compatible with the largest number of discs possible, it cannot be guaranteed that you will be able to play discs which might not be compatible with audio CD, VCD and SVCD standards.

NOTES ON CD-R/RW DISC

This unit is compatible with CD-RW/ CD-R discs for playback.

- Do not affix any type of labels to either side (recordable or labeled side) of a CD-R/RW disc as this may result in the unit malfunctioning.
- Do not load an unrecorded CD-R/RW disc into the unit. This may take a longer time to read the disc.
- **Playback capability for CD-RW discs may vary due to variations in the quality of the CD-RW disc and the recorder used to create the disc.**

Playback capability of CD-R, DVD-R and rewritable discs, compatibility with this player depends on the recorder, the burning software and the disc used

ATTENTION

This unit is incompatible with the following disc formats:

DVD-ROM, DVD-RW, DVD+RW, DVD RAM, DVD-R, CDV, SACD, DVD Audio (High resolution tracks). Data part of CD Extra, disc with non standard shape (e.g. heart), disc with region code different from the one specified on the back of the unit.

Getting Started

Connecting to Audio-Visual Components

ANALOG INPUT

Alternatively, if you have no VCR or SAT, you can connect any other compatible components like TAPE player, TV to your DVD receiver via the VCR/SAT input.

- VCR audio/video out will have output signal in SAT, DVD/CD and TUNER modes. When VCR (source) is selected, there will be no audio/video signal from VCR audio/video out.

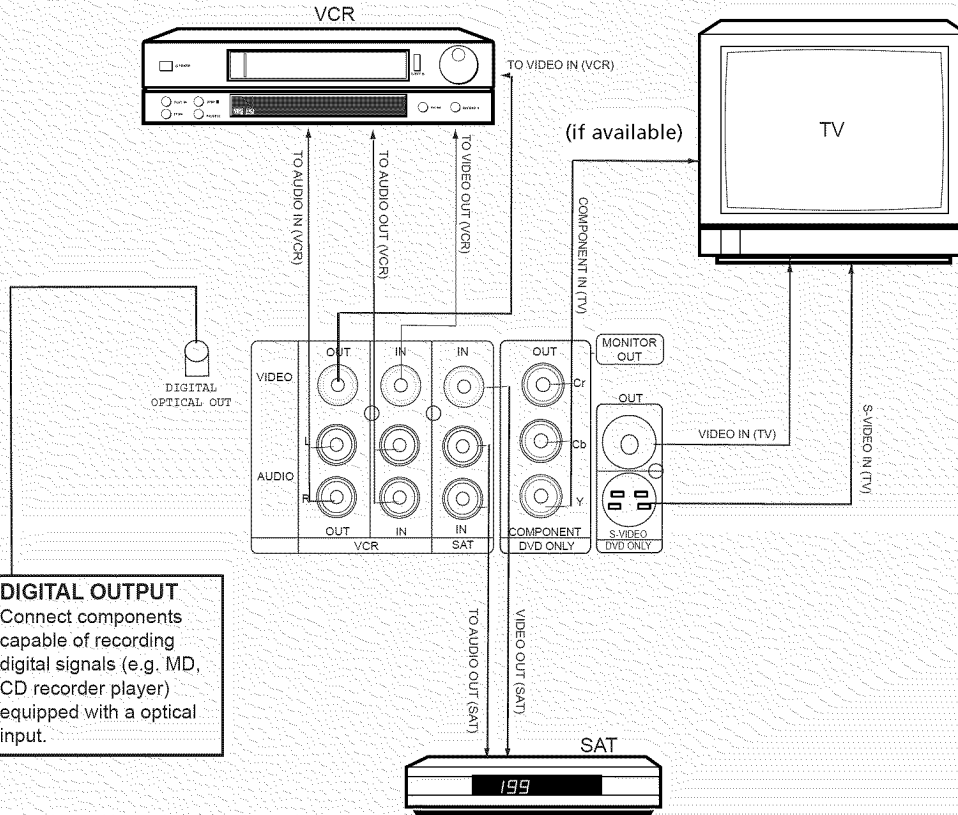

DIGITAL OUTPUT

Connect components capable of recording digital signals (e.g. MD, CD recorder player) equipped with a optical input.

S-VIDEO

S-video provides a better connection for the video portion of the signal than composite video (yellow color terminal). When connecting S-video cable, a Composite video cable (yellow RCA connector) must also be used. S-video will have video output for DVD playback only.

Component video output

Component video terminal provides the best connection for video. By separating the color information (Pb/Pr) and the luminance signal (Y), the image is improved comparing with S-video or composite video connection (result may vary on different TV / monitor). If your TV is equipped with these terminals (e.g. Y/Pb/Pr, Y/Cb/Cr, Y/B-Y/R-Y), use an appropriate video cable (75 Ohm) and connect to the system. Make sure to match the terminal color.

Progressive Scan

- It is necessary to use component video connection to enjoy progressive scan.
- Connect to a TV that has 480P input terminal or compatible with copy guard system, else the image will not be displayed properly.
- If progressive scan is ON, there will be no video signal output at composite video (VCR OUT), s-video and composite video monitor output. (Please refer to page 20 for details of activating progressive scan function)

Connecting the Antennas

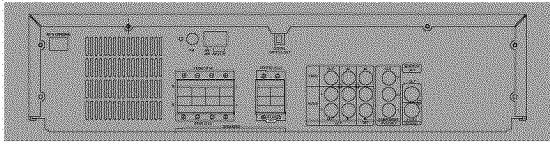

The AM and FM antennas connect to the AM and FM terminals on the system's back panel.

They must be hooked up in order to receive clear reception.

AM Loop Antenna and FM Indoor Antenna

1. Uncoil the AM Antenna wire.
2. Press down on the Antenna tab to open the terminal.

Note: Make sure the white wire on the AM loop antenna is inserted into the left terminal.

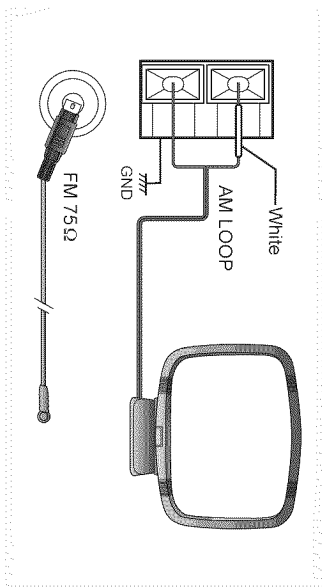

HINT

EN

- For FM reception, extend antenna to its full length and arrange the Antenna at different parts of the room until the reception is optimized.
- For AM reception, rotate the antenna horizontally to get better reception.

Getting Started

Connecting the Speakers

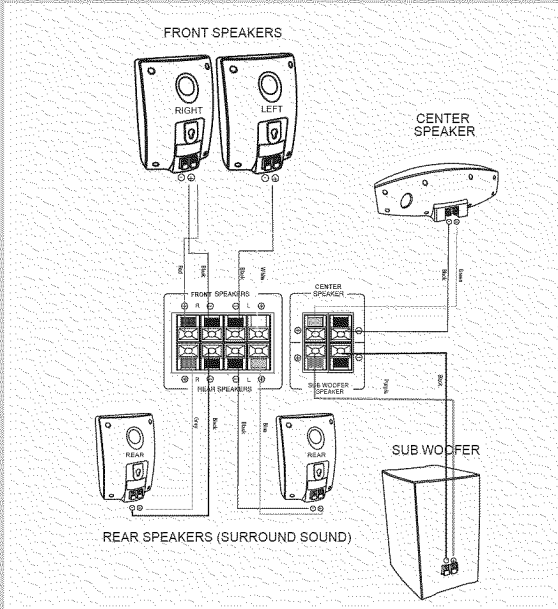

Speakers

There are 6 speakers equipped with the unit (2 front, 1 center, 2 rear, 1 subwoofer). In order to enjoy good surround effects all six speakers need to be connected to the receiver

For better sound quality, center speaker, rear speakers and Subwoofer should also be connected. Adding center and rear speakers will enhance surround effects. Adding a Subwoofer will increase bass response.

If you want to enjoy the full sound range use the subwoofer with the speakers to maintain adequate bass signal.

Speaker cords

1 for each speaker, is needed for connection. Twist the stripped ends of speaker cord about 2/3 inch (15 mm). Press down on the tab to open the terminal and insert the wire. Release tab to lock wire in the terminal.

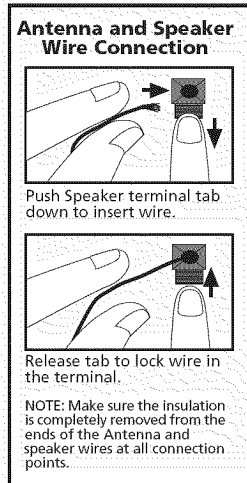

To ease speaker connections, the speaker cords and the terminals are color-coded.

- White/Black (Front Left Speaker),
- Red/Black (Front Right Speaker),
- Green/Black (Center Speaker)
- Blue/Black (Rear Left Speaker).
- Grey/Black (Rear Right Speaker).
- Purple/Black (Subwoofer)

Connect the speaker wire to the back of L, R front speakers and to the corresponding color terminals on the rear of the receiver. Do the same for center speaker, rear speakers and the subwoofer.

Speaker Polarity

When connecting the speakers, make sure the polarities ("+" speaker wire to "+" on the receiver) of speaker wires and terminals are matched. If the cords are reversed, the sound will be distorted and will lack bass ("out of phase" effect).

Do not ground the output line, it will cause damage to the speaker.

Connecting the Subwoofer

Connect the subwoofer with the speaker wire (purple/black) provided.

Positioning your speaker

1 Left, Right (Front Speakers)

They carry primarily music and sound effects.

2 Center

In surround mode, the center speaker carries much of the dialogue as well as music and effects. It should be set between the left and right speakers.

3 Surround (Rear Speakers)

Their overall sound balance should be as close as possible to the front speakers. Proper placement is vital to establish an evenly distributed sound field.

Subwoofer

A subwoofer is designed to reproduce powerful low bass effects (explosions, the rumble of spaceships, etc.) which dramatically heightens involvement with the action on the screen. It is therefore recommended to connect subwoofers when small speakers are used.

Magnetic shielding

Speakers placed less than two feet from the TV set must be magnetically shielded in order to prevent picture distortion. Front and center speakers provided with this unit are magnetically shielded to protect your TV set.

It is not recommended to place the rear speakers near the TV set.

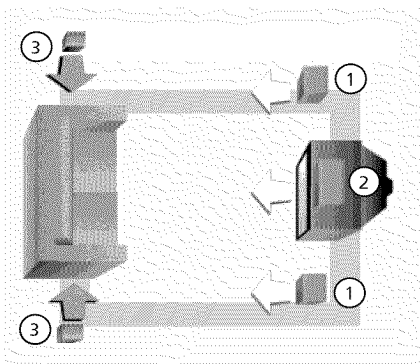

Courtesy Dolby Laboratories

Front Speaker Placement

Even if you can't duplicate this ideal home theater setup exactly, the suggestions for speaker placement that follow will help you get good results.

Alignment

Align the center speaker evenly with (A), or slightly behind (B), the left and right speakers, but not ahead of them.

EN

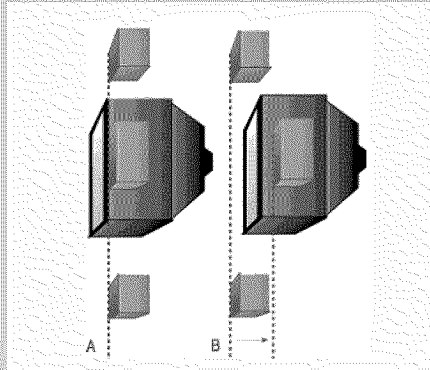

Courtesy Dolby Laboratories

Advanced Setting

Angle

Placing the left and right speakers to form a 45-degree angle with your favorite viewing position will duplicate the soundtrack mixer's perspective.

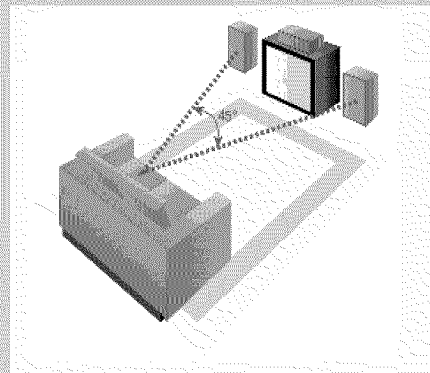

Courtesy Dolby Laboratories

Height

The mid- and high-frequency drivers of the three front speakers should be as close as possible to the same height. This often requires placing the center speaker directly atop (A) or beneath (B) the TV set.

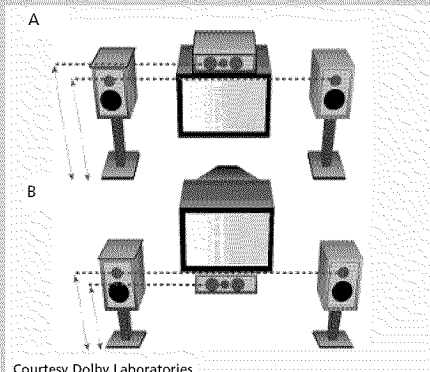

Courtesy Dolby Laboratories

Getting Started

Preferred surround placement

Location

If possible, place surround speakers to either side of the listening area, not behind it.

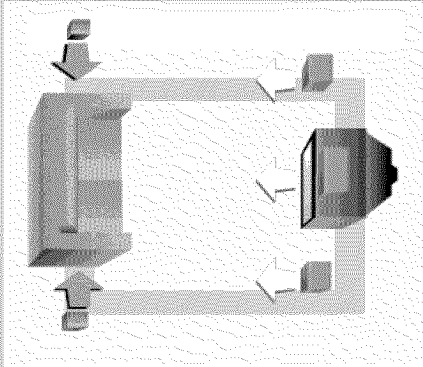

Courtesy Dolby Laboratories

Height

If space permits, install surrounds 2-3 feet above viewers. This helps to minimize localization effects.

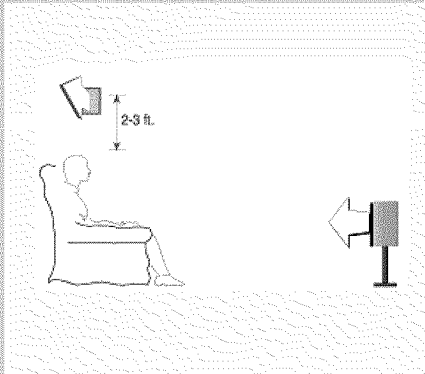

Courtesy Dolby Laboratories

Aiming

Aiming surrounds straight across the room, not down at viewers, helps create a more open, spacious surround sound field.

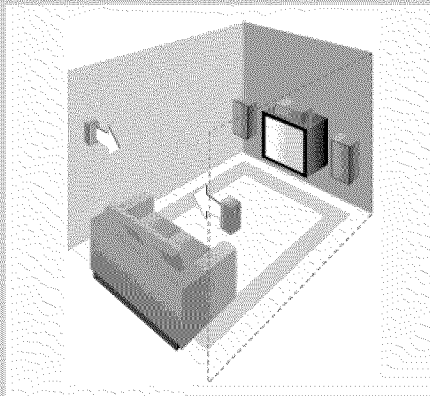

Courtesy Dolby Laboratories

Advanced Setting

Alternative Surround Placement

Rear wall

If rear wall mounting is the only choice, aim the speakers at each other (A), towards the front (B) or even towards the sidewalls (C, D). Experiment with placement until surround sounds seem to envelop you, rather than coming from behind you.

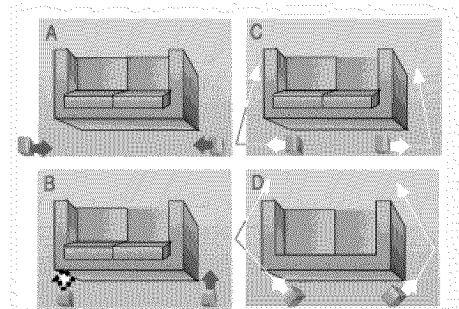

Courtesy Dolby Laboratories

No adjacent walls

Surrounds can go on stands facing each other (A), or to approximate the preferred sidewall mounting (A), or to the sides or rear of the viewing area aimed upwards. In the latter case, they can go right on the floor, or preferably, a few feet off the floor such as on end tables (B).

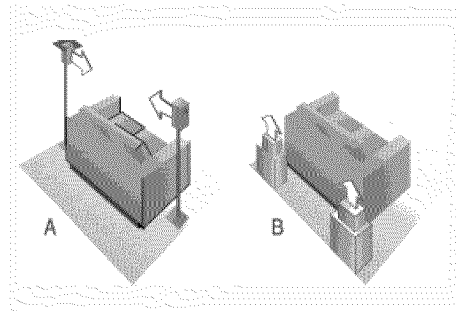

Courtesy Dolby Laboratories

Test Tone / Channel balance

Channel balance

Your receiver is equipped with a test signal generator for balancing the channels. As the signal "travels" from channel to channel, adjust the level controls until each channel plays at the same loudness level. Please refer to "Fine setting your speaker" section for more details.

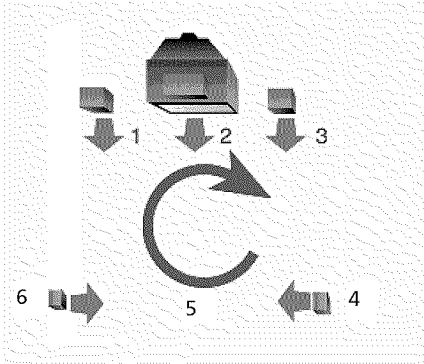

Courtesy Dolby Laboratories

Level adjustment & surround channel level expectation

Even though you adjust the surround channel to be as loud as the others on the test signal, you'll find that on actual program material the surround channel is usually much lower than the front. Don't be tempted to readjust the surround level; program producers use surround mostly for subtle atmosphere and ambience, and only rarely for special effects. A good surround mix doesn't call attention to itself; if it did, it would soon become distracting.

NOTE

The system is equipped with Dolby Digital, and manufactured under License from Dolby Laboratories.



Dolby Digital
Manufactured under license from Dolby Laboratories. "Dolby", "Pro Logic" and the double-D symbol are trademarks of Dolby Laboratories. Copyright 1992-1997 Dolby Laboratories, Inc. All Rights Reserved.

Using Headphones

To listen privately through your audio system, use the PHONES jack on the receiver. However, make sure you turn down the volume before you put on the headphones. Increase the volume to the desired level after headphones are in place.

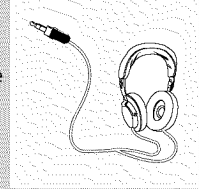

Once headphones are connected, "HEADPHONE DOWNMIX 2 CHANNEL" will scroll on display. This feature automatically converts multi-channel outputs to 2 channel stereo for your listening pleasure.

Hearing Comfort & Well-Being

- Do not play your headset at a high volume. Hearing experts advise against continuous extended play.
- If you experience a ringing in your ears, reduce volume or discontinue use.

Factory Setting

The unit is preset to the following setting when you first turn on the power.
Source = TUNER
Volume setting = 25
Bass & Treble = 0 dB

Restore to Factory Settings

You can always restore all settings back to its original state. When the receiver is in VCR mode, press the following sequence on the main unit to restore all settings back to factory default :

STOP → REPEAT → BAND / APP



Manufactured under license from Digital Theater Systems, Inc. US Pat. No. 5,451,942, 5,956,674, 5,974,380, 5,978,762 and other world-wide patents issued and pending. "DTS" and "DTS Digital Surround" are registered trademarks of Digital Theater Systems, Inc. Copyright 1996, 2000 Digital Theater Systems, Inc. All Rights Reserved.

NOTE

All preset radio stations and surround sound setting will be lost after factory setting is restored.

Operating Your Receiver

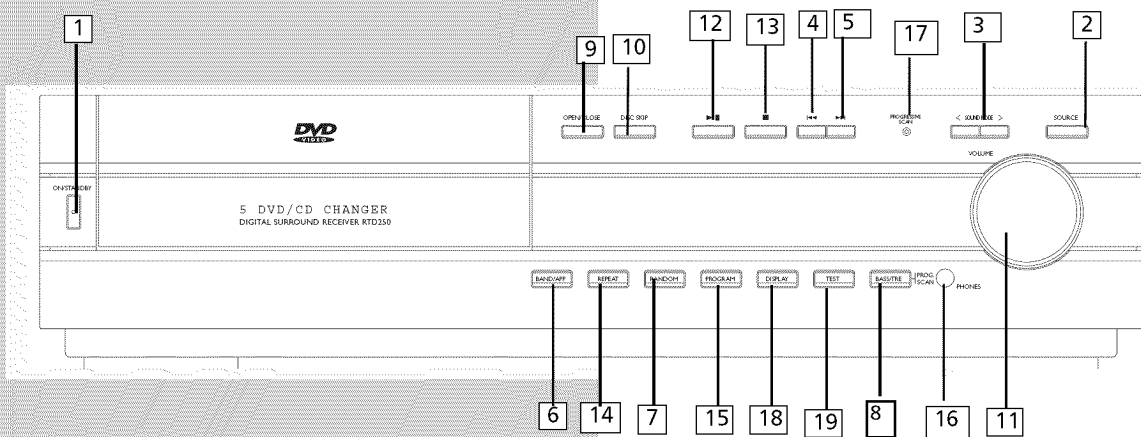

Receiver Controls

1. ON / STANDBY

• To turn the unit on/ off. When the system is turned on, the unit will go to ECO mode (red light will be on), then press the ON/STANDBY button to power the unit up in the last mode used.

2. Source Button

• To select input source. For example, DVD/CD, VCR, etc.

3. < SOUND MODE >

• Press to select the surround sound setting or Digital Sound Processor (DSP) mode you want. Refer to "Advanced Sound Control" on page 16.)

4. PRESET - / SKIP REVERSE

• To move back to the beginning/previous preset memory location in tuner mode.
• To skip to the beginning/previous track in CD mode and the beginning/previous chapter in DVD mode (only while playing).

5. PRESET + / SKIP FORWARD

• To go to the next preset memory location in tuner mode.
• To skip to the next track in CD mode and the next chapter in DVD mode (only while playing).

6. BAND / APP

• In Tuner mode, press to select between radio BANDS or press and hold to enter AUTO PROGRAM mode.

7. RANDOM

• In DVD/CD mode, press to activate Random function.

8. BASS / TRE (PROG. SCAN)

• To adjust BASS / TREBLE, press this button once to choose either bass or treble, then press preset + and preset - to adjust level. (Bass/ treble adjustment is not allowed for DTS source)
• 1. Press and hold to activate progressive scan.
2. Press to toggle between on/off within 3 seconds.
3. Release to validate.

9. OPEN / CLOSE

• Press to open / close the CD door. (You may replace all non-playing discs during playback.)

10. DISC SKIP

• Press to skip to the next disc in the tray.

11. VOLUME

Turn the knob to adjust volume level.

12. PLAY/PAUSE

To play and pause DVD/CD playback.

13. STOP

To stop DVD/CD playback.

14. REPEAT

• Press to toggle on the repeat function in DVD/CD playback.
• In CD mode : refer to CD / mp3 player section.
• In DVD mode: refer to DVD player section.

15. PROGRAM

• Press to toggle on the program function in DVD/CD playback.
• In CD mode : refer to CD / mp3 player section.
• In DVD mode: refer to DVD player section.

16. PHONES

Plug your headphones (not supplied) into it for your private enjoyment. Speakers will be off when phones are inserted.

17. BLUE LED

• When progressive scan is turned on, the blue light will be on.
• When in protection mode, the blue led will blink continuously,

18. DISPLAY

• Press to toggle among track elapsed time / track remain time / disc elapsed / disc remain time (Audio CD only)

19. TEST (DVD/CD mode only)

• Press **STOP** if the set is playing.
• Press **TEST** to enable test tone function for adjustment of speaker level individually.
• Press **LEFT/RIGHT** key on remote to decrease / increase the level of channel which is showing on the VFD until you can get the correct level from the corresponding channel.
• Press **PLAY** to quit setting and playback or press **STOP** to quit only.

Remote Control

Please be sure you have inserted the batteries into the remote control (see relevant section on page 3.) You can test it by pressing any button. If it works, the red LED will light.

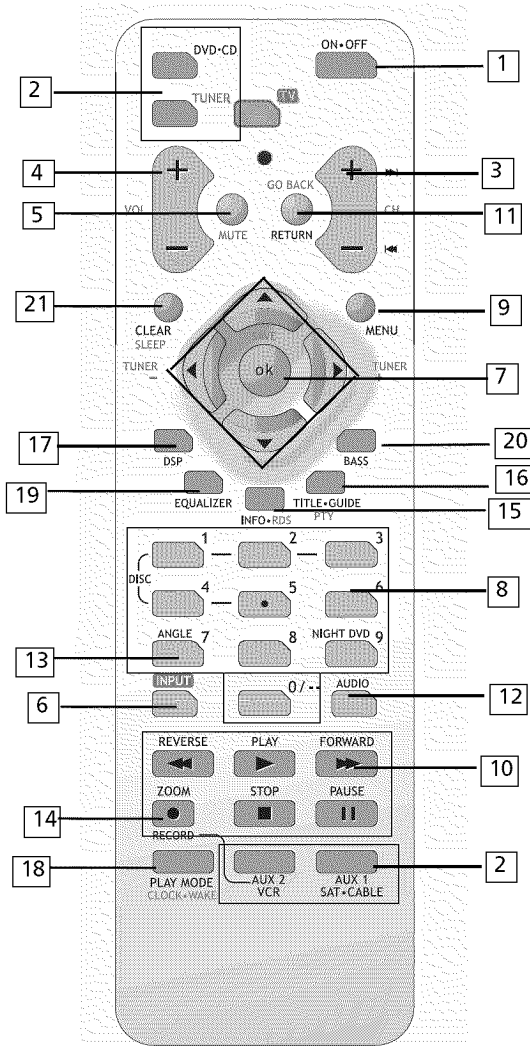

1. ON-OFF

- To turn on or off the receiver and other auxiliary components (see page 14 "Using the Remote to Control Additional Components").

2. Source Buttons

- To turn on and select various audio/ video sources.

3. CH+, CH- (Channel Buttons)

- To select programmed stations in TUNER mode.
- To skip to the next or previous chapter, track or image in DVD, CD, mp3 and JPEG mode.

4. VOL+, VOL- (Volume Buttons)

- To adjust the volume.

5. MUTE

- To mute / unmute all audio outputs.

6. INPUT

- Press to select VCR or TV input.

7. Adjustment Buttons

- In all mode except DVD, press OK key will enter into function setting mode, for DVD mode, press and hold the OK key is needed.
- Press OK for DIMMER mode and level adjustment.
- When the display shows the setup you want to change (dimmer, speaker level, etc), press the left and right arrow buttons to choose, and press up and down buttons to make changes, then press OK to finalize your choice.

8. Number Buttons

- In Tuner mode, to select a preset station.
- In DVD/CD mode, enable pull down menu by INFO*RDS key (Button 15), then press OK key to select field to be adjusted. Press Number Buttons to direct input the settings (e.g. CD track)
- In DVD/CD mode, when there is no OSD info are displayed, press Button 1 to 5 to select disc; when there is OSD showing, press number buttons to adjust settings (e.g. CD track)

9. MENU

- In Tuner mode:
 - Press TUNER to select band
 - Press to store desired frequency in memory. The flashing word PROG in red will appear in display. Input your desired channel number while the word is still flashing and the frequency will be stored. (For details, refer to "Storing Radio Stations" under "Manual Preset" on page 38)
- In DVD mode, press for menu setup for DVD title.

10. Operation Buttons

- TUNER, press TUNER on the remote to enter tuner mode. In TUNER mode, you can press TUNER to select band, and press LEFT and RIGHT buttons to tune down or up the radio frequency.

11. RETURN

- Press to go back to previous menu or exit setup menu completely

12. AUDIO

- Press to select the audio channel you like. (e.g. LEFT / RIGHT)
- In Tuner mode, press this button to switch from ST to MONO mode and vice-versa.
- In DVD mode, press to select different audio channel (if available).

13. ANGLE (DVD only)

- Press to select different screen display angles.

14. ZOOM (DVD only)

- Press to select the zoom ratio.

15. INFO-RDS

- Press to display playback information.

16. TITLE-GUIDE

- Press to go to the title menu at DVD mode.

17. DSP

- Press to change the surround sound settings. The display will toggle among any stereo modes (for DTS (DTS stereo), for DOLBY DIGITAL signal (Dolby Digital, 3 Stereo, Stereo), DOLBY PL II MOVIE, DOLBY PL II MUSIC, DOLBY PRO LOGIC EMULATION, DOLBY 3 STEREO, ARENA, JAZZ CLUB, THEATER, STADIUM, DISCO, STEREO)

18. PLAYMODE

- Press to toggle between different playmodes. (Random, repeat, etc.)

19. EQUALIZER

- Press to toggle between different preset equalizer mode (only available in stereo mode.).

20. BASS

- To adjust BASS / TREBLE, press this button once to choose either bass or treble, then press LEFT/RIGHT to adjust level. (Bass/ treble adjustment is not allowed for DTS source)

21. CLEAR / SLEEP

- Press once to enter SLEEP mode.

Operating Your Receiver

Display



DVD / VCD / CD / mp3

- Unit in DVD, VCD, CD or mp3 mode.

DIGITAL

- Audio output is in Dolby Digital mode. (For DVD only)

PRO.LOGIC II

- Audio output is in Dolby PL II Movie, Dolby PL II Music or Dolby Prologic Emulation mode.

DTS

- Audio output is in DTS mode. (For DVD input only)

RANDOM

- Random playback mode activated.



- Currently in playback mode.



- Currently in pause mode.



PARENTAL LOCK

- Parental lock is on and a password is required to view DVDs above a specific rating level.

TITLE

- Title number for DVD playback.

TRACK

- Track number being played.

CHAP

- Chapter number for DVD playback.

PROG.

- Program mode is activated.

TUNED

- Tuner station detected.

ST

- Tuner stereo signal detected.

REPEAT / REPEAT TRACK / REPEAT CHAP / REPEAT A.B. / REPEAT FOLDER (mp3 only)

- CD, mp3 and DVD in repeat mode.

KHz / MHz

- Tuner frequency unit.

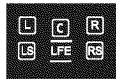

- Speaker Icons.

SLEEP

- Sleep mode is activated.



- Display disc information
- Larger number refers to the current disc being played.

Switching on /off

- To switch on the receiver, press the **ON/STANDBY** button on the receiver once to enter standby mode. Press the **SOURCE** button on the receiver or one of the source buttons or ON/OFF button on the remote control to power on the receiver.

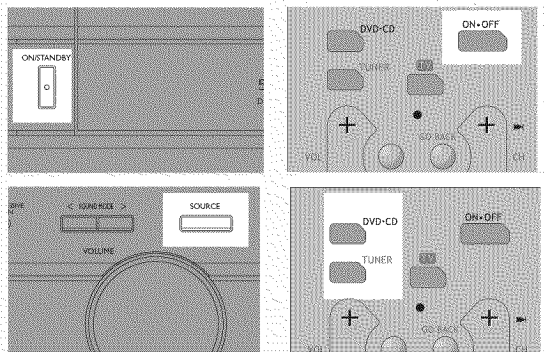

- Standby: when the receiver is on, press the **ON/OFF** on the remote or the **ON/STANDBY** button on the receiver to return to standby mode.

NOTE

Your receiver has a 2-week back up memory to avoid losing settings such as preset radio stations in case of power outage. If the receiver is unplugged for more than 2 weeks, all the settings will be lost and re-setting will be necessary.

Selection of Audio/Video source

When one of the audio/video source is selected, the audio and video input corresponding to the name will be activated.

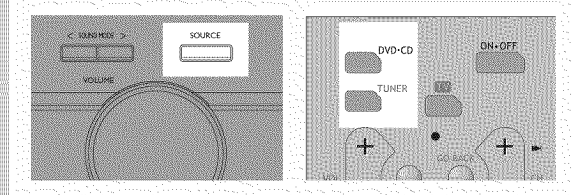

The receiver acts as a switching device between all the sources that are plugged into it.

Example 1:

If you connect a VCR player to the VCR input (audio + video) on the receiver and press the **SOURCE** button until VCR shows on the display. You will be able to have the sound and image transmitted by the VCR.

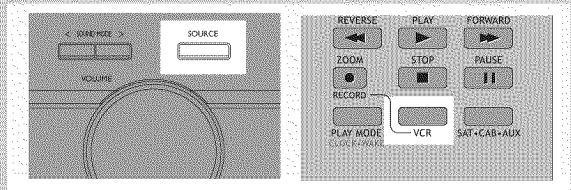

Operating your Receiver

You can connect up to 2 audio/video sources to this amplifier:

Source button (remote control)	Corresponding connector (receiver back panel)
- DVD/CD	built-in
- TUNER	built-in
- SAT	SAT IN (audio / video)
- VCR	VCR IN (audio / video)

When a source is selected, the source name is shown on the display.

Example: Press the **VCR** button to select VCR as the source to the amplifier.



NOTE

1. Your receiver has a built in tuner. Just connect the appropriate antenna to the back of the receiver and you will be able to listen to radio stations. (See details in Tuner section)
2. The receiver is also equipped with DVD/CD player. Press the **SOURCE** button on the main unit or **DVD** button on the remote to activate the feature.
3. Other sources (TV,tapes,etc) can be connected to this unit provided that the connections are compatible.
4. Refer to the "Connecting To Audio-Visual Components" section for details on connection.

Using the Remote to Control Additional Components

You can set up your remote to control a TV of another brand. You simply need to enter the code into the remote control. (not necessary for recent RCA & Proscan models).

1. Turn on the component to be programmed.
2. Look up the brand and corresponding code number in the code list.
3. Press and hold the **TV** button on the remote while entering the code from the code list using the Number Buttons.

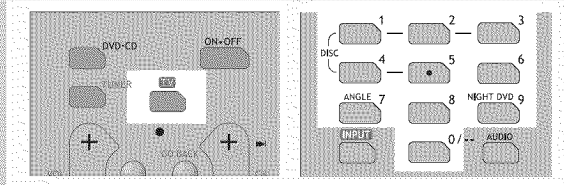

4. Release the component button, then press the **ON•OFF** button to see if the component turns off.

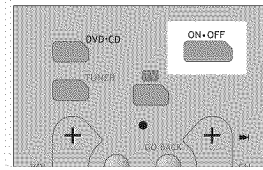

5. If this does not work, repeat steps 3 and 4 by trying to use the next code (if available) listed for the brand of your component until the component responds to the remote command.

Volume punchthrough

By default, the **VOL+ /VOL-** and **MUTE** buttons will only control the DVD receiver, regardless which mode (TV, VCR, etc) the receiver is in.

By programming the volume punchthrough function, you can also control the volume of the TV.

NOTE: Controlling the TV volume can only be done in TV, VCR and SAT.CABLE mode, not in DVD/CD and TUNER mode.

To activate the volume punchthrough function, follow the procedures below:

1. Press and hold the **VOL-** button.
2. While pressing it, press the device button (TV, VCR or SAT.CABLE) that you are programming the volume punchthrough. The red led will turn off.
4. While you are still pressing the **VOL-** button, press the device button that you want the volume command to punch through from, the red led will turn on until the **VOL-** button is released.
5. Removing the batteries will reset the remote such that once again the receiver **VOL+/-/MUTE** codes are sent in TV mode.

Note: If an invalid key is pressed, the remote led blinks four times, then you will have to start over again.

NOTE

Once your remote is encoded, you can press **ON/OFF** on the remote once to turn off the component and then followed by the second time quickly to turn off the receiver (i.e. this unit). If you only want the receiver to be turned off, select **TUNER** or **DVD/CD** while the unit is ON before pressing **ON/OFF**.

HINT

This remote may not operate all models of the brands shown. If batteries are removed from the battery compartment of the remote control, all memory may be lost. If this is the case, you will need to re-enter all previously programmed codes again. The remote buttons may not work exactly like the original remote buttons for components of other brands. Experiment with the remote and your components to see which buttons work. If only a few functions work, you may try another code to check if more buttons work.

Sound Enhancement Systems

This receiver is equipped with several built-in sound enhancement systems.

Dolby Pro Logic II

The Pro Logic II mode uses the built-in circuit to steer the Left, Center, Right and Surround left and right channel audio signals and uses all five speakers to play both stereo and Dolby Pro Logic program source, such as TV and VCR. Dolby Pro Logic II includes Dolby Pro Logic II Movie, Dolby Pro Logic II Music and Dolby Pro Logic Emulation.

You can use this mode to suit any stereo program source (such as VCR / SAT) to enjoy multi-channel sound experience).

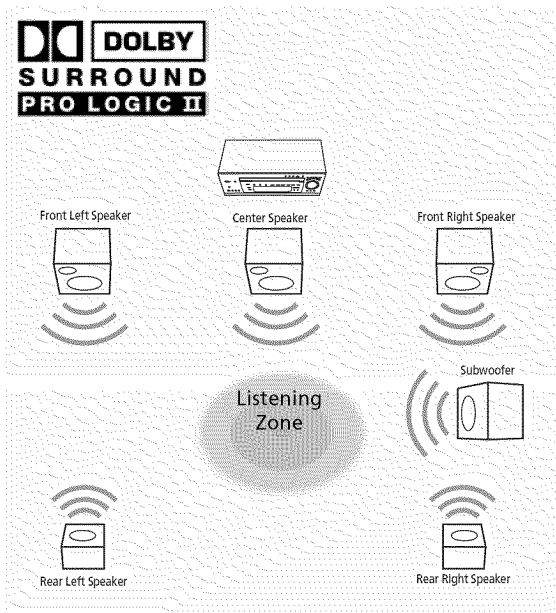

Dolby 3 Stereo

The 3 Stereo mode will redirect the Surround signals to the front left and right speakers when only the front and center speakers are used.

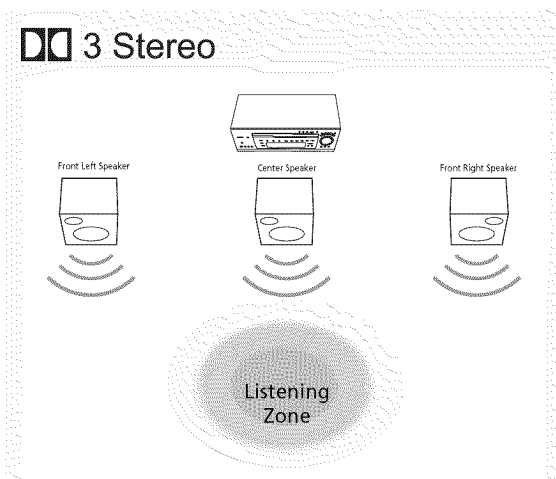

Dolby Digital

The Dolby Digital mode lets you enjoy full digital surround from software processed in the Dolby Digital format. Dolby Digital provides better sound quality and a more powerful presence than conventional Dolby Surround.

This unit is equipped with Dolby Digital 5.1-channel so that you can enjoy enhanced full digital surround sound. Different from Dolby Pro Logic in that only four channels (Front Left, Front Right, Centre and Rear) are used, the new system provides stereo separation of the rear speakers (Rear-Right, Rear-Left). Adding the to the 5 channels the subwoofer channel for bass sounds (counted as 0.1 channel) results in 5.1 channels (or 6 Channels) that bring you the most sophisticated Dolby Digital sound enjoyment.

Digital Theater Systems (DTS)

DTS is a digital surround system which delivers six channels of master-quality, 20-bit audio. It offers five full-range channels plus a special low frequency effect (LFE) channel for subwoofer, resulting in what is commonly known as 5.1 channels. It can be applied with existing 5.1 speaker configurations.

DTS is available in DVD and CD mode.

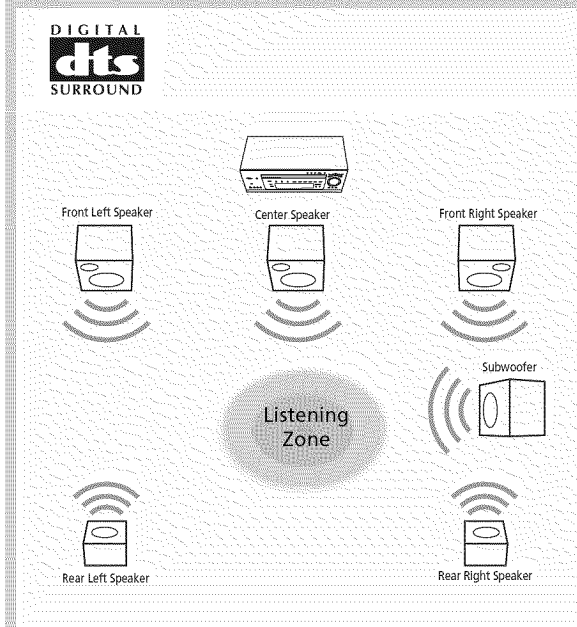

Advanced Sound Control

Stereo

The Stereo mode uses the two main channel outputs from the front speakers.

Fine Setting of the Components

The receiver can be directly turned on by pressing the SOURCE Buttons (like DVD/CD, SAT), which also selects the best surround sound mode. The default surround modes for different components are as tabled below.

If you decide to change the surround mode, you can press the **AUDIO** button repeatedly to toggle among the different surround mode choices and select the one you want.

For Digital Signal (2ch PCM), or analog signal , VCR, Tuner, SAT:

Dolby PL II Movie ➤ Dolby PL II Music ➤ Dolby PL Emulation ➤ 3 Stereo ➤ Arena ➤ Jazz Club ➤ Theater ➤ Stadium ➤ Disco ➤ Stereo

For Digital Signal (Dolby Digital)

Dolby Digital ➤ 3 Stereo ➤ Stereo ➤ Dolby PL II Movie ➤ Dolby PLII Music ➤ Dolby PL Emulation

For DTS Signal

DTS ➤ Stereo

Default Settings

The receiver will keep the last selection in memory as long as it doesn't enter standby mode.

Input Signal Setting

The receiver defaults to the most convenient settings for your easiest use (see table).

Source/ Source/ Input	If PCM bitstream	If Analog Input selected
DVD/CD	PRO-LOGIC II MOVIE	N/A
SAT	N/A	PRO-LOGIC II MOVIE
VCR	N/A	PRO-LOGIC II MOVIE
TUNER	N/A	PRO-LOGIC II MUSIC

SOURCE	DEFAULT INPUT (as seen on display)
SAT	Analog (SAT/ CAB)
VCR	Analog (VCR)
TUNER	Built-in Tuner
DVD/CD	Built-in

SOURCE	AVAILABLE INPUT
SAT	ANL
DVD/CD	Built-in
VCR	ANL
TUNER	Built-in

Analog Input

Select this setting to play analog signals from VCR or SAT.

DSP (Digital Sound Processor)

These digital sound effects resemble sounds in a real environment such as Arena, Jazz Club, Theater, Stadium and Disco. DSP automatically converts analog audio signals to digital ones which enables you to adjust the sound without degrading the sound quality. Different modes will give you different feels of size and types of listening environment. (Not available in Dolby Digital and DTS)

Night Mode

By using Dynamic Range Compression technology, you can enjoy enhanced Dolby Digital sound quality at night without interrupting your roommates or neighbors. Night Mode will compress the volume difference between normal voices and sounds such as explosions, while still enjoying a Dolby Digital DVD experience. Night Mode can be activated by pressing the **NIGHT** button on the remote, DRC SOFT (Default) will appear on the display. While DRC SOFT (Default) is still on the display, press the **LEFT** or **RIGHT** adjustment buttons, around the **OK** button, until you select the desired mode. There are three modes (OFF, SOFT, SOFT-ER) for you to choose the extents of compression.

NOTE

SAT and VCR are just generic names. You can connect other compatible audio/video components to these inputs like TV, TAPE, MINI DISC, CD-RW player, etc.

Fine Setting of the Speakers

All the basic settings have already been pre-set for the speakers included in the box.

However, to make the surround sound more effective and suit the acoustic conditions in your listening room, you may need to delay the signal coming from some of the speakers. Channel delay compensates for center or surround speakers that are closer to the listening position than the front speakers.

You may setup the speakers channel by channel: first, press the MENU button while in stop mode to enter the setup menu, then choose Speaker Setup.

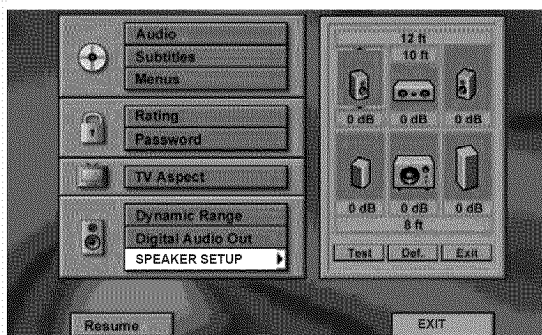

To change the speaker size

In the speaker setup menu, press the left or right button to select a speaker. When the speaker picture is selected, you may press the up or down button to adjust the speaker size. The speaker size selection allows you to setup the device for larger size speakers, such as floor stand speakers.

To change the speaker distance

In the speaker setup menu, press the left or right button to select a speaker. When the speaker distance column is selected, you may press the up/down button to adjust the distance from the front, rear and center speakers individually.

To change the speaker level

In the speaker setup menu, press the left or right button to select a speaker. When the speaker level column is selected, you may press the up/down button to adjust the level of the front, rear and center speakers individually.

To test the speaker setting

In the speaker setup menu, press the left or right button to select the "test" column, then press OK to activate. A short noise will then come from the speakers, one speaker at a time.

IMPORTANT NOTE

- The speakers provided with this unit are considered as small speakers. DO NOT select the large speaker setting as this may shorten the life of the speakers and affect the unit performance. We recommend to NOT change the speaker size setting if you use the speakers included in the box.
- Always use the subwoofer for optimum sound quality.

Advanced Setting

Factory Default Setting

The receiver speaker distance default settings are the following:

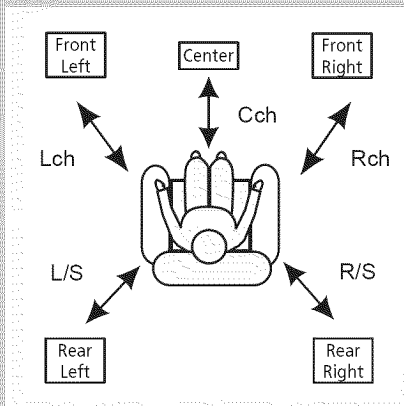

Front speakers (L/R)	15 ft
Center speaker (Cch)	15 ft
Rear speaker (SUR)	10 ft

Advance Sound Control

Speaker Icons

The receiver shows you the speakers' settings on the display with the following icons:

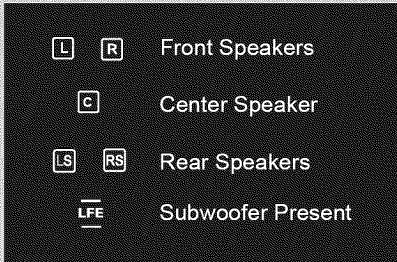

Displaying Program Formats

When a digital source starts playing, the receiver automatically switches to the proper surround mode and provides setting information via the speaker icons located on the right-hand side of the display. (See diagram)

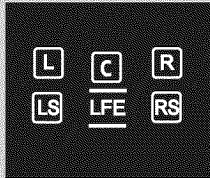

It is important to note, however, that not all Dolby Digital sources are encoded with the full complement of five channels plus LFE*. Speaker icons show how many and which speaker you have enabled (See "Fine Setting of the Speakers") and the letters inside the speaker icons show which channel is present in the source information. For example, the diagram shown means you have all five speakers and subwoofer enabled and the digital sources you played have five channels plus LFE complemented. (Dolby Digital 5.1 Channels)

* LFE stands for Low Frequency Effect. The indication "LFE" appears if the digital source contains LFE information. In this case, the bass signal will be delivered to the subwoofer, offering more dynamic deep bass sound effects. If the letter is flashing, the signal is either too weak or just gone.

Basic Playback Features

1. To select the DVD/CD input source, press the **SOURCE** button on the main unit until "DVD/CD" appears on the display. You may also directly press the DVD/CD source key on the remote.

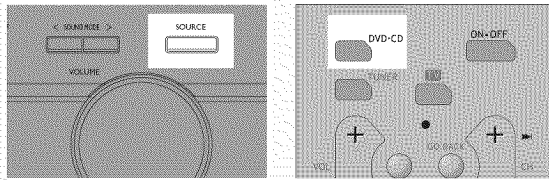

2. Press **OPEN/CLOSE** to open the tray and load a disc, with the label facing up. Press **OPEN/CLOSE** again to close the tray.

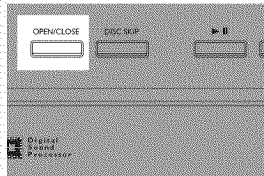

3. When **READING** disappears from the display, playback starts automatically from the beginning of the disc, or the disc menu is displayed on the screen.

- Press **PLAY/PAUSE** on the unit or **PAUSE** on the remote to pause playing during playback. Press **PLAY/PAUSE** on the main unit or **PLAY** on the remote to resume normal playback.

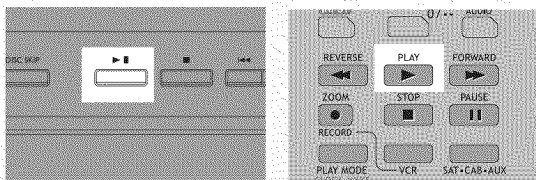

- Press **SKIP REVERSE** to go back to the previous chapter or **SKIP FORWARD** to move to the next chapter.

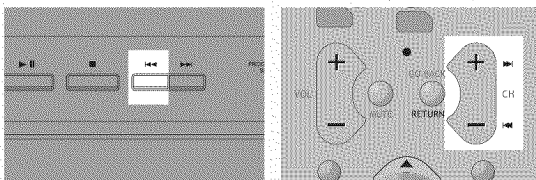

- Press **STOP** once to stop playback and go into resume mode.

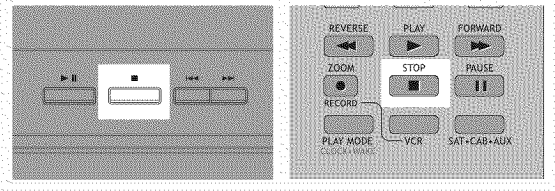

EN

NOTE

RESUME MODE:

The next time **PLAY** is pressed, the unit will begin playback at the location where it was last stopped. Press **STOP** key again to cancel the resume mode.

Quick search

1. While playing a disc, press **REVERSE** on the remote control to scan backwards through the disc. Press **FORWARD** on the remote for scanning forward.

Press repeatedly to change searching speed to 1,2 or 3 times for VCD and 1,2,3 or 4 for DVD.

2. Press **PLAY** at any time to resume normal playback.

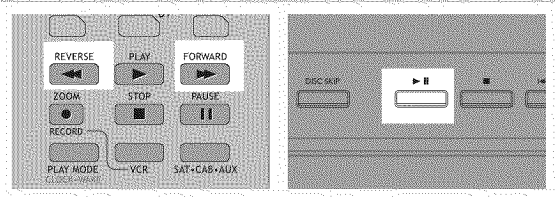

Freeze frame, frame advance

1. Press **PAUSE** on the remote control to freeze the picture during playback. Each time you press it again, the next frame is displayed.

2. Press **PAUSE** repeatedly to move forward in still frame mode.

3. Press **PLAY** to resume normal playback.

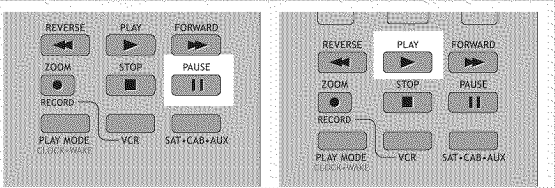

DVD Player

Slow motion playback

1. Press **PLAY/PAUSE** on the main unit or **PAUSE** on the remote control to freeze the picture during playback.

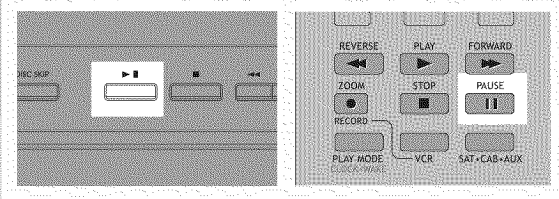

2. Advance picture in slow motion. Press **FORWARD** on the remote control for forward slow motion and **REVERSE** (DVD only) for reverse slow motion. Press repeatedly to change speed to 1/16 times, 1/8 times, 1/4 times and 1/2 times.

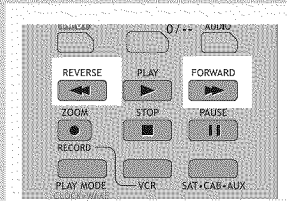

3. Press **PLAY/PAUSE** on the main unit or **PLAY** on the remote control to resume normal playback.

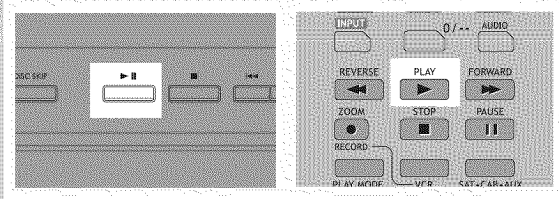

Progressive scan

1. Make sure the component output is connected to a TV which accepts progressive scan signal. To enable progressive scan, press and hold **BASS / TRE** for 3 seconds in **STOP** mode.

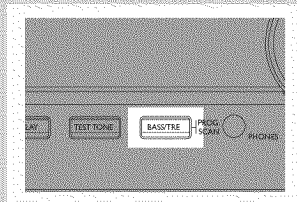

2. Once the progressive scan ON/OFF status is displayed, press the **BASS/TRE** key to toggle between ON and OFF. Wait for 3 seconds: the blue light will be on if the progressive scan function is active.

Note: The progressive Scan function can only be selected in **STOP** mode.

On-screen banner display

You can access the on-screen banner display during playback to select many playback features. Each feature is illustrated with an icon. However, each feature shown in the banner is available only if the disc was created with that particular feature.

An invalid icon appears on the screen when you select an icon that does not function. Also, the icon is "grayed out" to tell you so. 

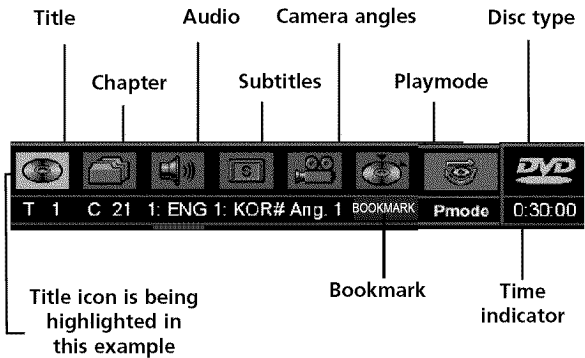

General use

1. Press **INFO-RDS** on the remote control during playback to show the on-screen info banner.

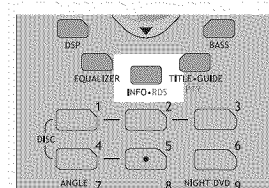

2. Use the **LEFT** or **RIGHT** arrows on the remote control to move the cursor on the banner. the selected feature icon will be highlighted.

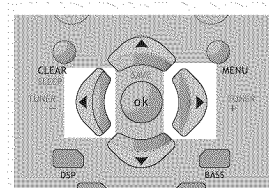

3. Press **OK** to open the menu corresponding to the selected feature.

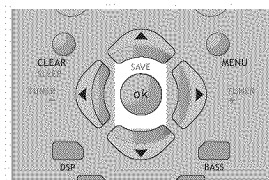

Selecting a title

1. Refer to the previous page "General use" to open the title menu.
2. Enter a title number using the number keys on the remote control. Add 0 in front of single-digit title number (e.g. 9 = 09). You can also use UP/ DOWN key to change the title number.

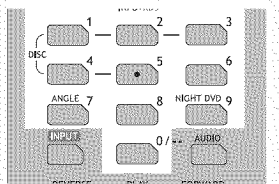

NOTE

Some discs have one title only.

Selecting a chapter

1. Refer to the previous page "General use" to open the title menu.
2. Enter a chapter number using the number keys on the remote control. Add 0 in front of single-digit chapter number (e.g. 9 = 09). You can also use UP/ DOWN key to change the chapter number.

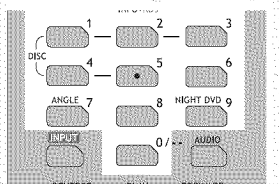

NOTE

The chapter feature will not work if the disc is not formatted with separate chapters.

Selecting audio language

1. Refer to the previous page "General use" to open the subtitle menu, or press **AUDIO** on the remote control to select the audio channel.

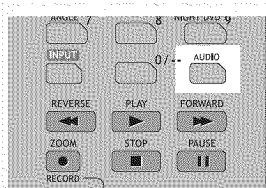

2. Press the **UP/DOWN** key to select the audio channel you want, then press **OK** to confirm.

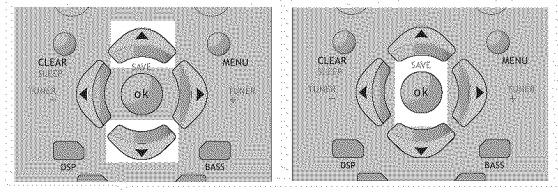

EN

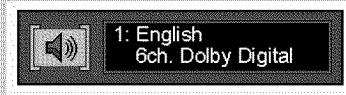

NOTE

This feature only works if the disc was created with multiple audio tracks.

Selecting subtitle language

1. Refer to the previous page "General use" to open the subtitle menu.

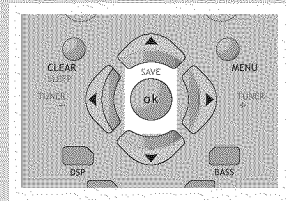

2. Press the **UP** or **DOWN** key to select the subtitle you want, then press **OK** to confirm.

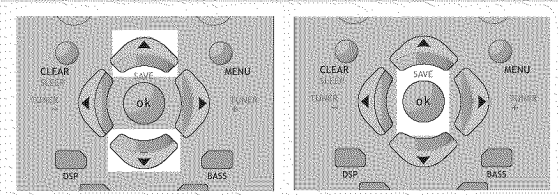

NoteL To exit the OSD banner, press the **INFO** key.

NOTE

This feature only works if the disc was created with subtitles.

DVD Player

Selecting camera angle

1. Refer to page 20 "General use" to open the camera angle menu, or press **ANGLE** button on the remote.



2. Press the **UP** or **DOWN** key to select the audio channel you want, then press **OK** to confirm.

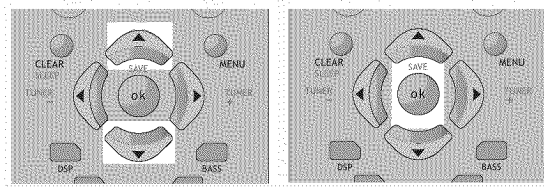

NOTE

This feature only works if the disc was created with multiple angles.

Selecting zoom ratio

1. Press **ZOOM** button on the remote to select the zoom ratio.

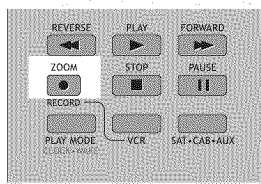

2. There are two zoom ratio available, press the zoom key to access the following zoom sequence.

NORMAL > ZOOM 1 > ZOOM 2 > NORMAL

Using bookmarks

The bookmark feature allows you to mark a point on the disc for quick access. You can store up to 9 bookmarks.

Adding bookmarks

1. Refer to Page 20 "General use" to open the bookmark menu.

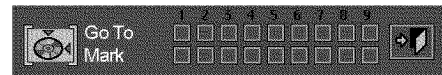

2. Use the arrows on the remote to move the cursor (yellow frame) to the "**Mark**" check line, then press **OK** to add a bookmark when reaching a scene of interest.

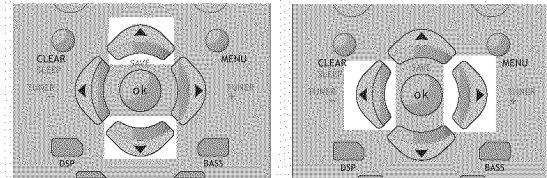

3. To add another bookmark, move the cursor to the right with the arrow button. Then, press **OK** to add a bookmark when reaching a scene of interest.

4. Move the cursor to the door icon and then press **OK** to exit menu.



Recalling bookmarks

1. Refer to page 20 "General use" to open the bookmark menu.

2. Use the arrows on the remote to move the cursor (yellow frame) to the "Go To" check line and to the bookmarked scene you want to recall.

3. Press **OK** to recall the bookmarked scene.



4. Use the arrow buttons to move the cursor to the door icon, and then press **OK** to exit the menu.

Clearing bookmarks

The bookmarks are cleared each time a disc is removed from the player or when the power is turned off completely.

If all 9 bookmarks are in use, you can still mark new scenes but the previous bookmarks will be erased starting from the earliest one.

Play mode

1. Refer to page 20 "General use" to open the playmode menu.
2. Press the **up/down** buttons to select among :
Normal >Program edit/ Program play > Repeat AB > Repeat Title > Repeat Chapter > Normal
3. Press OK to confirm the setting.

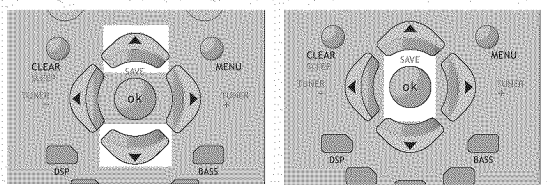

NOTE

Random playback is not available in DVD mode.

Program playback

Edit program

1. Refer to the previous page ("General use") to open the play mode menu, or press and hold the **PROGRAM** button on the front of the unit to access the program mode.

Note: Program edit can only be activated during STOP / Resume mode. However, if there is program saved already, program play can be activated during playback mode.

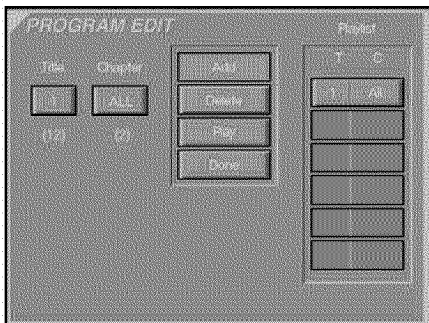

2. The box under "Title" will be highlighted automatically. Use the arrows on the remote to select title and chapter.

EN

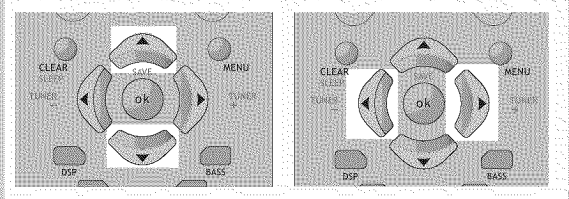

3. "Add" will be highlighted automatically after chapter is selected. Press **OK** to add selected track and chapter(s) onto playlist.

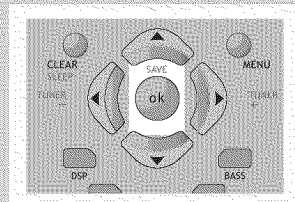

4. Move to highlight "Play" (start program playback) or "Done" (return normal playback with program saved), then press **OK** to start program playback or return to stop mode.

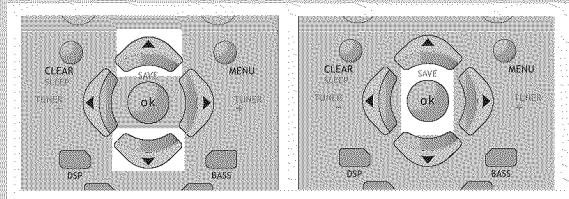

NOTE

You can select at maximum 32 items by repeating steps 2 - 3.

DVD Player

Delete program

1. Select the **PROGRAM** menu from the OSD banner, or press and hold the **PROGRAM** button on the main unit to display the program edit playlist.

2. Use the arrows on the remote to select and highlight the programmed item you want to delete from the playlist

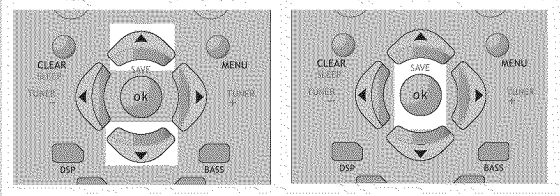

3. Highlight "Delete" and then press **OK** to delete the item.

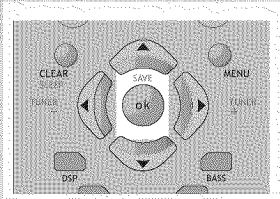

4. Repeat steps 2 and 3 to delete additional items.

5. Use the arrows to select and highlight "Play" (start program playback) or "Done" (return to normal playback with program saved) and then press **OK**.

Insert chapter

1. Select the **PROGRAM** menu from the OSD banner, or press and hold the **PROGRAM** button on the main unit to display the program edit playlist.

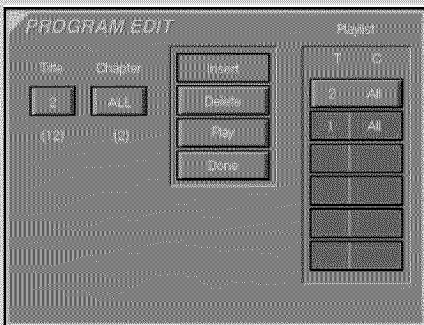

2. Use the **UP** or **DOWN** arrow to highlight and select on the playlist the item before which you want to insert a chapter.

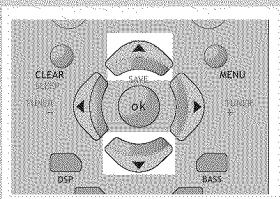

3. Use the **LEFT** and **RIGHT** arrows to select Title or Chapter, then the **UP** and **DOWN** arrows to select the number.

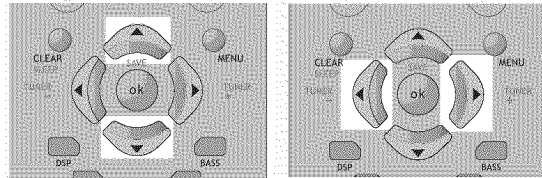

4. Use the **LEFT** and **DOWN** arrows to highlight "Insert" and then press **OK**.

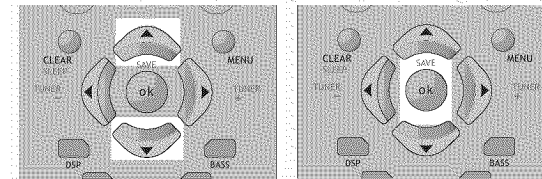

5. Use the arrow buttons to highlight "Play" (start program playback) or "Done" (return to normal playback with program saved) and then press **OK**.

Cancel program

Program will be cancelled when;

1. the disc tray is opened;
2. power is turned off;
3. **STOP** is pressed twice. The red PGM indicator will disappear from the display and the player will resume its normal playback mode.

Set up menu

General use

1. Press **MENU** in STOP AND RESUME mode to display the set up menu on screen. The menu shows the current set-

NOTE

tings. *Pressing MENU during disc playback will display the disc menu, not the player setup menu.*

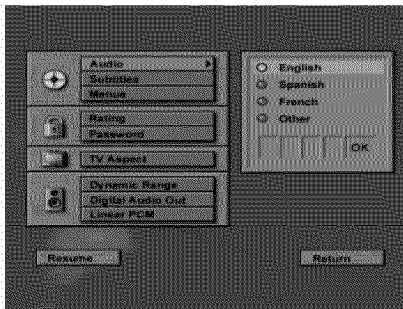
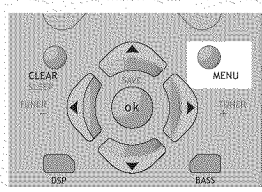

2. Use the arrow buttons to highlight an option and press

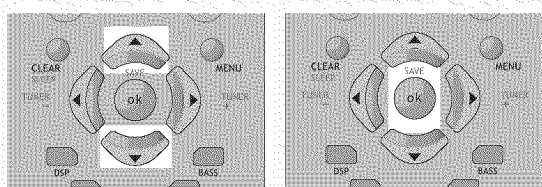

OK to open the selected menu.

3. Press the **LEFT** arrow to go back to the previous menu

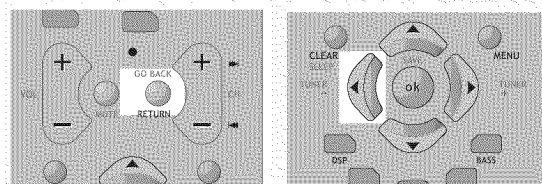

or press **GO BACK** to exit the setup menu completely.

Audio language

This step will define the default audio language. Choosing an audio language from the on-screen banner display will only overwrite this setting temporarily.

EN

NOTE

If the selected language is not available on a disc, that disc's own default language will be used instead.

1. Open the audio language menu.

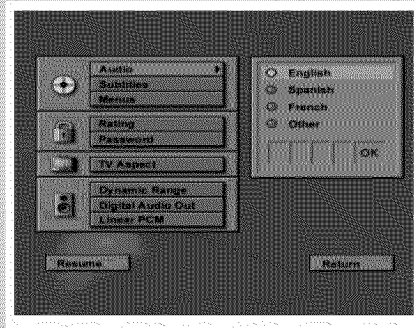

2. Use the **UP** and **DOWN** arrows to select a language and then press **OK**.

For languages other than the available options:

3. Press **DOWN** to select "Other" and then press **OK**.

4. Use 0-9 to enter the code for the chosen language, then select OK to return to the main menu..

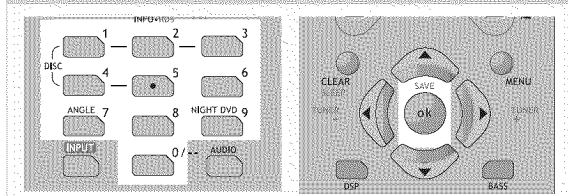

DVD Player

Subtitle language

This step will define the default subtitle language. Choosing a subtitle language from the on-screen banner display will only overwrite this setting temporarily.

NOTE

If the selected language is not available on a disc, that disc's own default language will be used instead.

1. Open the subtitle language menu.

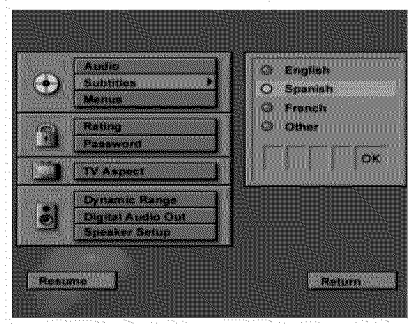

2. Press the **UP** or **DOWN** arrow to select a language and then press **OK**.

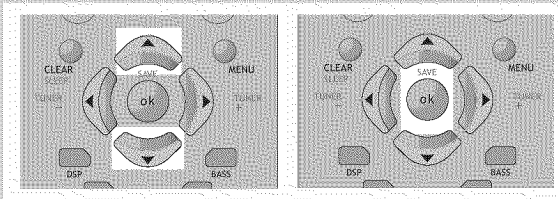

For languages other than the available options

3. Move down and select "Other" and then press **OK**.
4. Use 0-9 to enter the code for the chosen language, then select **OK** to return to the main menu.

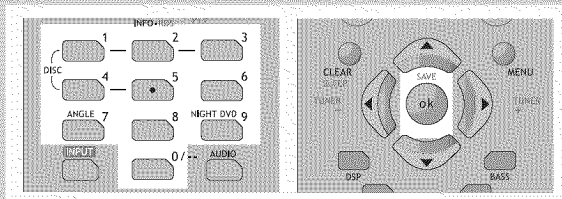

Menu language

This step will define the language of menus and other short messages shown on screen.

1. Open the menu language menu.

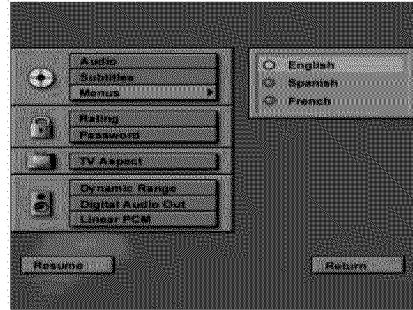

2. Use the **UP** or **DOWN** arrows to scroll the selections and select the language and then press **OK** to return to the main menu.

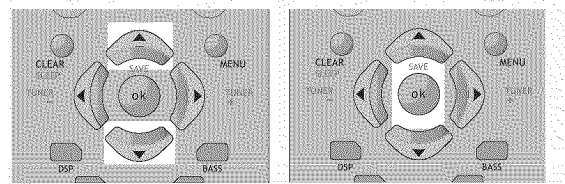

Rating (Parental control)

This setting prevents the playback of DVDs that may not be suitable for all audiences, by using the rating level that may be encoded on the disc. If the rating level of the disc is higher than the preset level (to be set in this step), the playback will be prohibited unless the password (see next step) is entered.

1. Open the rating menu.

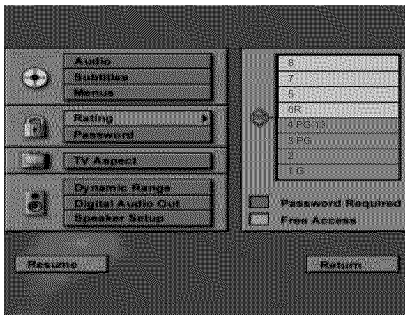

2. Use the **UP** or **DOWN** arrows to highlight the rating requiring a password to start disc playback. Press **OK** to return to the main menu. Ratings highlighted in blue require a password.

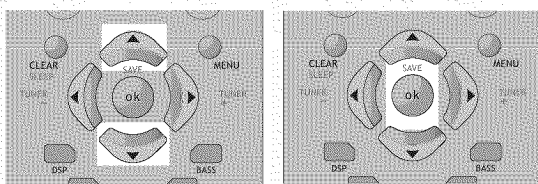

The rating feature works in accordance with the rating encoded in the DVD disc software. Keep in mind that all movies and discs may not be rated. In addition to the five standard (MPAA) rating symbols of "G" (level 2), "PG" (Parental Guidance, level 4), "PG13" (Parental Guidance and 13 years old, level 4), "R" (Restricted, level 6) and "NC17" (from 17 years old, level 7), the player includes a total of 8 rating steps, corresponding to the existing disc rating steps. These additional steps allow for a better control the of program playback for all audiences.

- Level 8: All DVDs can be played (Factory preset).
- Level 7 to 2: DVDs for general audiences/ children can be played.
- Level 1: DVDs for children can be played, DVDs for adults/ general audiences are prohibited.

Password

Set password

EN

To disable the viewing of rated DVDs, a four-digit password must be selected.

1. Open the "Set Password" menu.

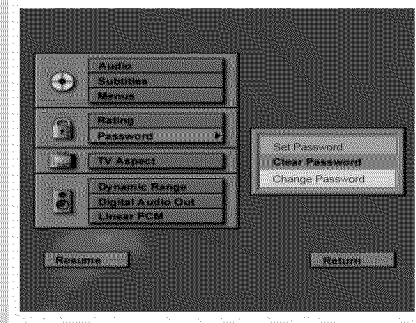

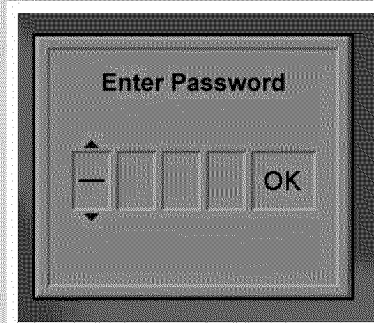

2. Select "Set Password" and press **OK**.

3. Use the number buttons to enter the password and then press **OK**.

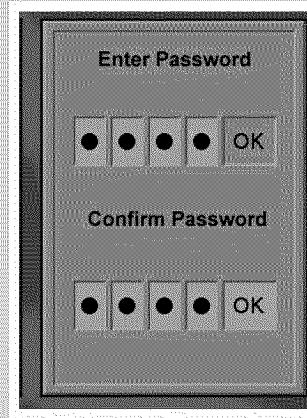

4. Repeat step 3 to confirm the password.



Note:  will be displayed on the VFD once the password is set.

NOTE

- when an incorrect password is entered, a new password menu appears so that you can enter and confirm the password again
- A lock icon shows on unit display when password is required to view rated discs.

Important: keep the password in a safe place or remember it reliably as access to rated discs or rating/ password menus requires the correct password.

Change the password

In order to change the password, the current password must first be entered

1. Open the password menu.

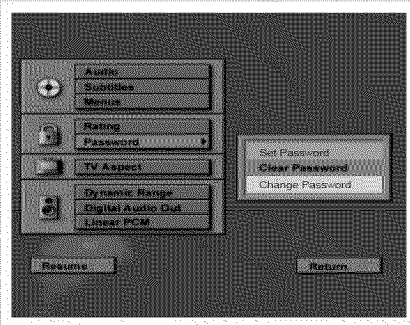

2. Use the number buttons to enter the password and then press **OK**.

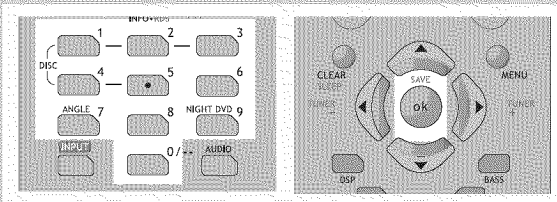

3. Use the **UP** and **DOWN** arrows to select "Change Password" and then press **OK**.

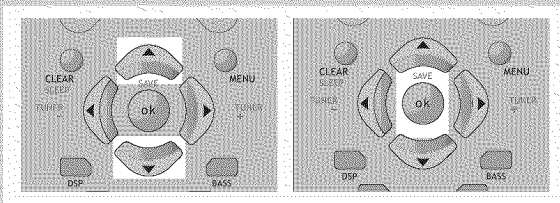

4. Use the number buttons to enter a new password and then press **OK**.

5. Repeat the above step to confirm the password and return to the password menu. Use the **LEFT** arrow to return to the main menu.

Clear password

1. Refer to page 25 "General use" to open the password menu.
2. Use the number buttons to enter the password and then press **OK**.
3. Move up or down the menu using the **UP** or **DOWN** arrows and select "Clear Password". Press **OK** to clear the password. Use the **LEFT** arrow to return to the main menu.

TV aspect

This step selects the TV aspect, wide-screen (16:9) or conventional (4:3).

1. Open the TV aspect menu.

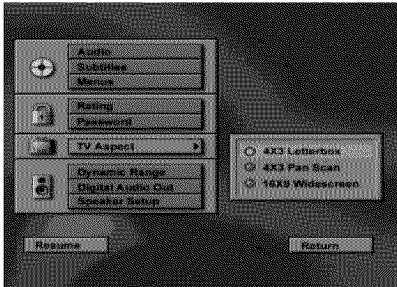

2. Use the **UP** or **DOWN** arrows to select TV aspect and then press **OK** to return to the main menu.

If you have a wide-screen (16:9) TV, choose "16:9 Widescreen".

- For 16:9 movie you will get (Do not select 16:9 widescreen setting if you are using a 4:3 TV set. or the image may look distorted with some DVD disc.)

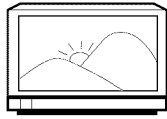

- For a 4:3 movie you will get

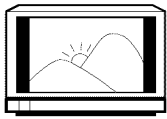

If you have a conventional (4:3) TV,
- if you select 4:3 letterbox for a 16:9 movie, you will get



- if you select 4:3 Pan Scan for a 16:9 movie, you will get (the left and right edges are hidden)

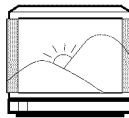

- for a 4:3 movie, for both selections, you will get

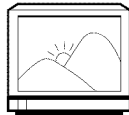

Note: You may need to deactivate progressive scan when viewing a video program recorded in 4:3 aspect. Some 16:9 TV set will not be able to adjust to 4:3 when progressive scan is ON. If this happens, try to disable progressive scan.

Dynamic range

1. To disable/enable the dynamic function, enter the dynamic range menu.

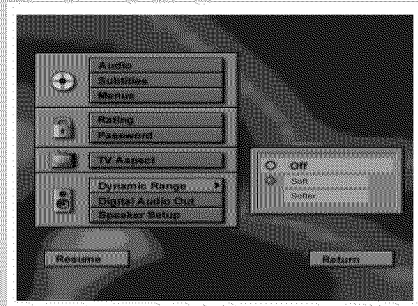

2. Use the **UP** or **DOWN** arrows to select Dynamic Range and then press **OK** to return to the main menu.

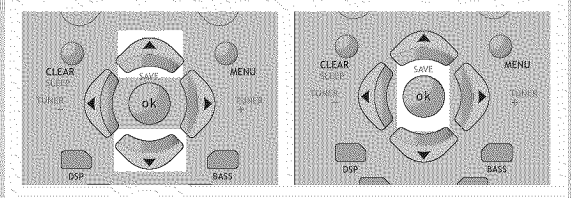

Digital audio out

1. To select digital audio out, enter the digital audio out menu.

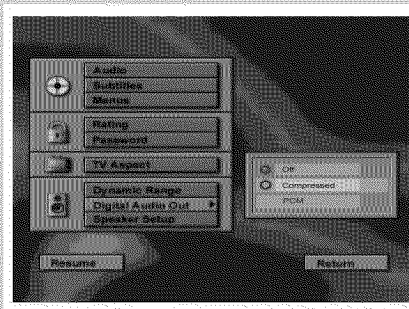

2. Use the **UP** or **DOWN** arrows to select digital audio out and then press **OK** to return to the main menu.

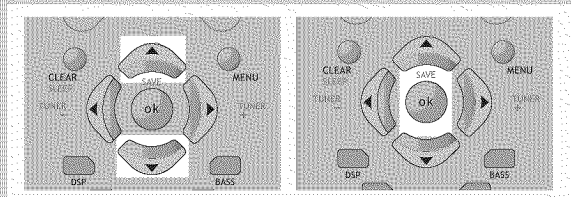

mp3 recommendations

- Use *.mp3* as the extension when converting audio files into mp3 for saving onto CD-R(W) or CD-ROM, e.g. *Rocky08.mp3*. Do not use any other extension e.g. *.doc*, *.pdf*.
- Do not use the *.mp3* extension for other text or non-audio data files as this may result in serious malfunction and harmful noise interference.
- Most commonly available CD creation software can make files compatible for the system but do not forget to finalize your disc after creation. This set cannot read DirectCD recordings.
- In order to get audio CD quality, you need to record your MP3 CD at 128 kbps. You can record up to 256 kbps. Beyond 256 kbps, the unit might not read the CD.
- Do not combine CD Audio and MP3 tracks onto a CD-R(W) or CD-ROM. The player will only playback CD audio tracks from mixed CD formats.

NOTE

- If over 400 items (songs/folders) are on the disc, only the first 400 songs can be played.
- Resume function does not operate in MP3 mode.

Loading and playing an audio CD

1. Press **OPEN/CLOSE** on the front panel to open the disc tray. Place the disc on the disc tray with the label side facing up. Press **OPEN/CLOSE** again to close disc tray.

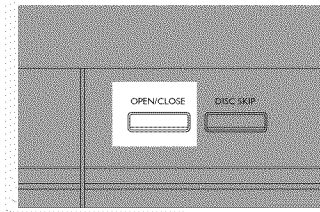

2. Press **DISCSKIP** or **1-5** on the remote control to select another disc. The disc will be read to detect whether an audio CD or mp3 CD has been inserted.

NOTE

If the CD is a MP3 audio CD, reading may take up to 2 minutes.

2. Playback begins automatically after the disc has been read. An audio CD **CD** or mp3 icon **MP3** will appear on the display.
3. Press **PLAY/PAUSE** on the main unit or **PAUSE** on the remote control to pause playback. Press **PLAY/PAUSE** again on the main unit or **PLAY** on the remote to resume normal playback.

The CD/mp3 playback function works in the same way as the features available for DVD.

Press **SOURCE** on the main unit or the DVD/CD source key on the remote to select the DVD/CD input source.

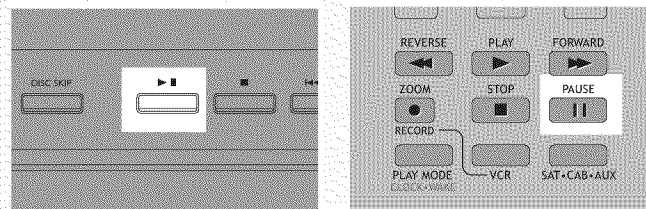
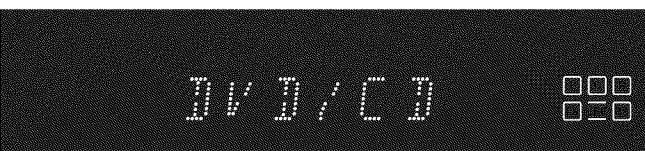
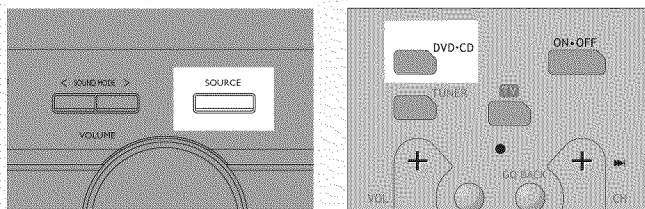

NOTE

Be sure to remove all the discs from the disc compartment before moving or transporting the unit!

4. Press **SKIP REVERSE** on the main unit or CH- on the remote to return to the previous track. Press **SKIP FORWARD** on the main unit or CH + on the remote to go to the next track.

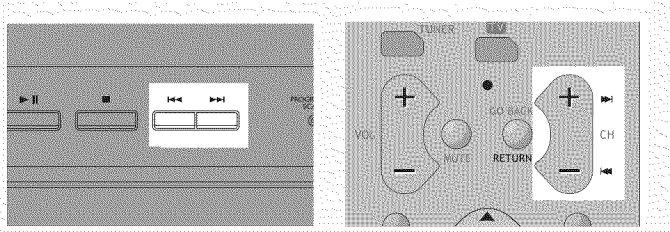

5. Press **STOP** on the main unit or **STOP** on the remote control to end playback.

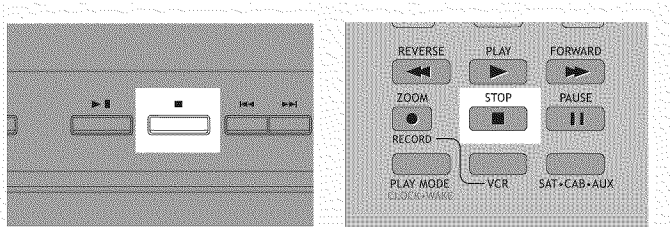

NOTE

When playback is interrupted, the location at which it stopped will be memorized. Playback will resume at the position it was last stopped. Resume playback does not work with mp3 music.

Quick scan

1. Press **FORWARD** or **REVERSE** on the remote to scan through a track quickly during playback. To change speed to 1, 2 or 3 times, press repeatedly during scan. Quick scan does not work with mp3 music.

EN

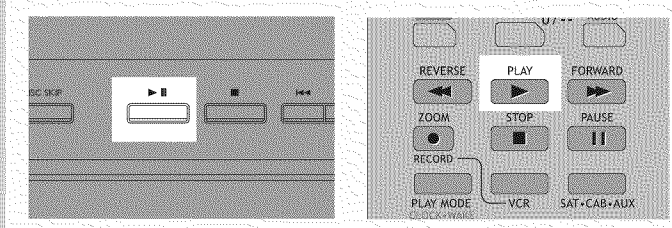
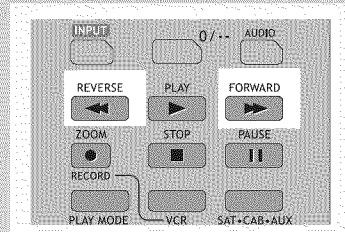

2. Press **PLAY** on the main unit or the remote to resume normal playback.

On- screen banner display for CD playback

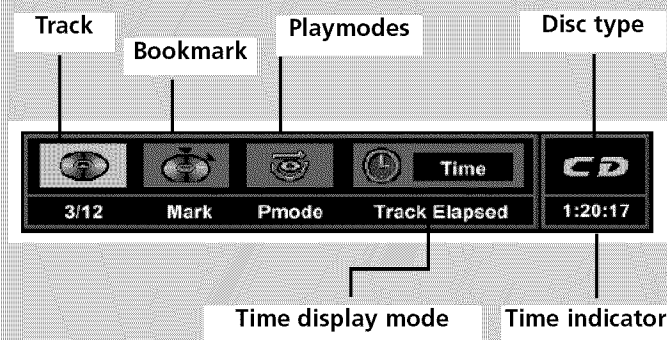

Selecting a track

1. Refer to "General use" to open the track menu.



2. Enter a track number. Start any single-digit track number by a 0 (e.g. 9 = 09).

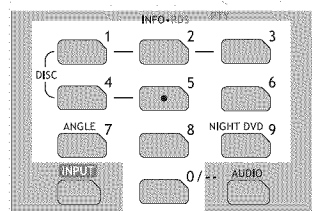

General use

1. Press **INFO** on the remote control to hide and show the on- screen banner. (Only audio CD banner)

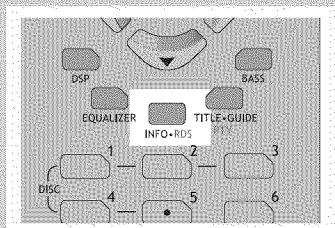

2. Use the **LEFT / RIGHT** arrow keys to move the cursor on the banner. The selected feature icon will be highlighted.

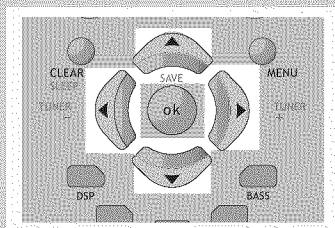

3. Press **OK** to open menu under the selected feature.

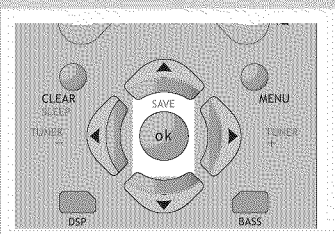

NOTE

You must be in playback mode for track selection.

Playmode selection for CD

There are several options for this feature.

- Normal** – normal CD playback
- Program** – plays the programmed tracks (usable in stop mode only)
- Repeat Disc** – repeatedly plays the selected or currently playing disc.
- Repeat Track** – plays one track over repeatedly.
- Repeat All Disc** – plays all discs in the tray repeatedly. (only workable when at least one of the discs is audio CD.)
- Random** – randomly plays all the tracks of that disc.
- Random All Disc** – randomly plays all discs in the tray repeatedly. (works only if at least one of the discs is an audio CD.)
- Repeat A-B** – repeatedly plays the selected time frame.

Program

Program edit - can be activated in STOP mode only.
 Program play - can be activated during playback mode if there is a saved program in the program list.

Bookmarks (Audio CDs Only)

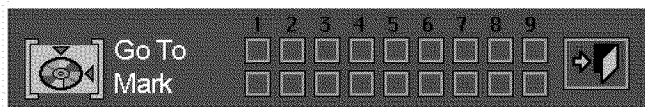

The bookmark feature allows you to mark a point on the disc for quick access. 9 bookmarks can be selected.

Adding Bookmarks (Audio CDs Only)

1. Refer to "General use" on page 32 to open the bookmark menu.



2. Use the arrow keys to move the cursor (green frame) to the "Mark" check line, then press **OK** to add bookmark when you reaching a point of interest.

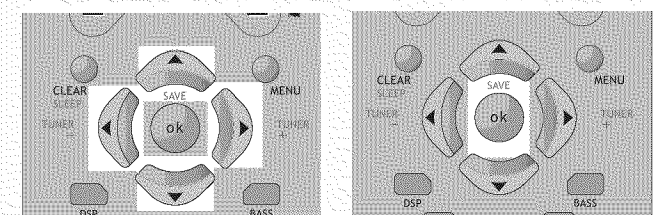

3. To add another bookmark, move the cursor to the right and then press **OK** when reaching another point of interest.

4. Move cursor to the door icon and then press **OK** to exit menu.



Recalling bookmarks

1. Refer to "General use" on page 32 to open the bookmark menu.

2. Use the **UP** arrow to move the cursor (green frame) to the "Go To" check line. Then, use the LEFT or RIGHT arrow to navigate to the bookmark you want to access.

3. Press **OK** to recall the bookmarked point.

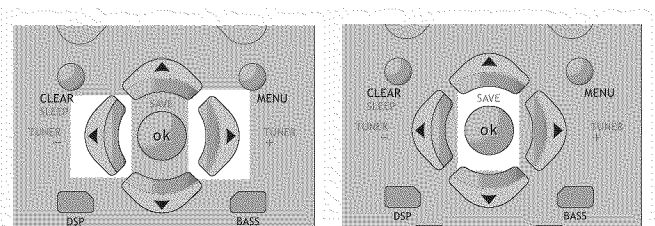

4. Use the arrow buttons to move the cursor to the door icon, then press **OK** to exit menu.



Clearing bookmarks

EN

The bookmarks are cleared each time a disc is removed from the player or when the power is turned off completely.

If all 9 bookmarks are in use, you can still mark new points but the previous bookmarks will be erased.

Time display (Audio CDs Only)

1. Refer to "General use" on page 32 to open the time display menu.

2. Press **OK** on the remote or **DISPLAY** on the main unit repeatedly to switch among "Track Elapsed", "Track Remain", "Disc Elapsed" and "Disc Remain" time during playback. The selected mode is displayed on the banner.

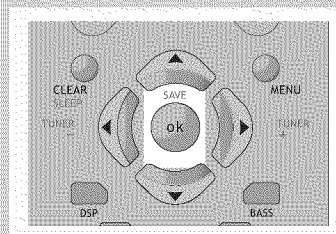

Program playback

Edit program

1. In STOP mode, press **PROGRAM** on the main unit or enter the OSD banner to display the edit playlist (program screen)

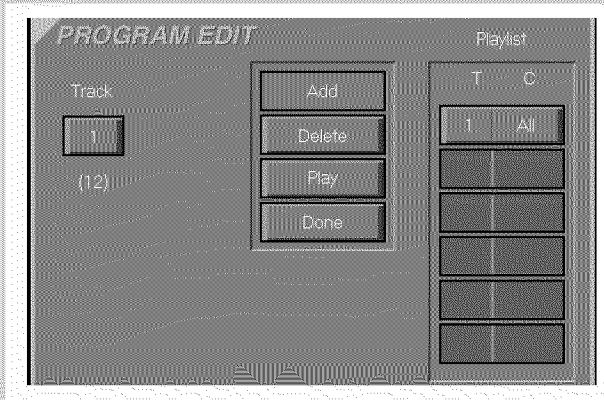

2. The box under "TRACK" will be highlighted. Press the **UP** or **DOWN** arrow or number buttons to select a track. Press **OK**.

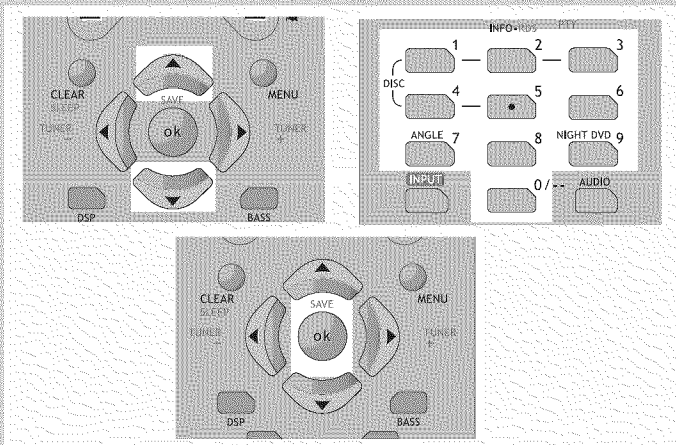

3. "Add" will be highlighted automatically after track is selected. Press **OK** to add the selected track to the playlist

4. Repeat steps 2 and 3 to add additional tracks to the program.

5. Move to highlight "Play" (start program playback) or "Done" (return to normal playback with program saved) and then press **OK** to confirm program playback or return to the stop mode.

NOTE

You can select a maximum of 32 items

Delete Program

1. In stop mode, press **PROGRAM** on the main unit or enter the OSD banner to display the edit playlist (program screen)

2. Use the **LEFT** or **RIGHT** arrow to select Playlist, then use the **UP** or **DOWN** arrow to select and highlight the programmed track you want to delete from the playlist.

3. Use the arrow buttons to highlight "Delete" and then press **OK** to delete a track.

4. Highlight "Play" (to start program playback) or "Done" (to return to normal playback with program saved) and then press **OK**.

Insert track

1. In stop mode, press and hold **PROGRAM** on the main unit or enter the OSD banner to display program edit playlist.

2. Use the arrows to highlight on the playlist the item before which you want to insert a track.

3. Refer to "Edit program" to select a track to be inserted.

4. Highlight "Insert" and then press **OK**

5. Highlight "Play" (start program playback) or "Done" (return to normal playback with program saved) and then press **OK**.

Cancel program

Program will be cancelled when;

1. the disc tray is opened;
2. power is turned off;
3. **STOP** is pressed twice. The PROG indicator will disappear from the display, and the player will resume normal playback.

On- screen display for mp3 playback

Standard Play

File mode

1. In the playmode window, press the **UP** or **DOWN** arrow on the remote to select the standard mode.

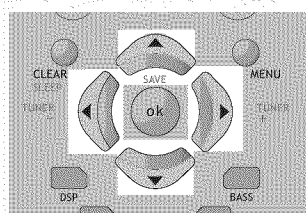

2. Use the **LEFT** or **RIGHT** arrow on the remote to toggle between different mp3 windows.

3. In the file window, use the **UP** or **DOWN** arrow buttons on the remote to select the file you wish to begin playing.

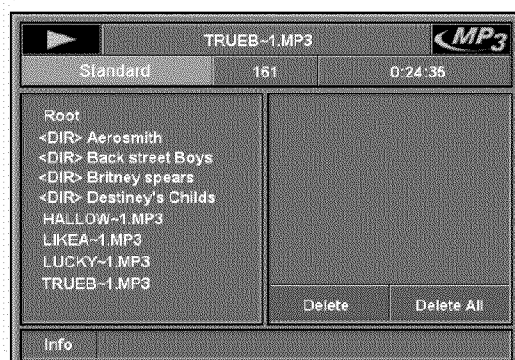

2. Press **PLAY/PAUSE** on the main unit or **OK** on the remote control to start playback. If an mp3 is already playing, press the OK button to play another mp3 file. All the files or folders will be played starting with the one you have selected.

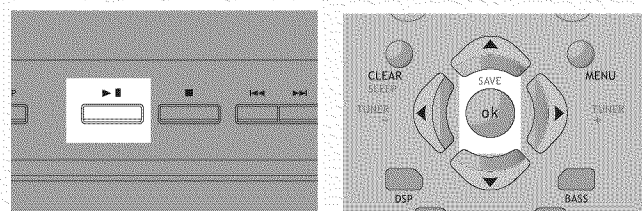

Playback stops when all the files have been played.

Folder mode

1. Use the arrow buttons on the remote to select the folder you wish to play.

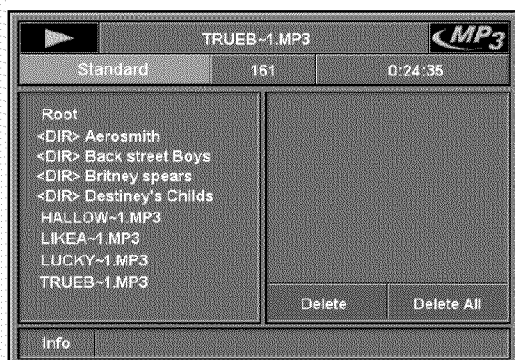

2. To playback all the files contained in the folder, press **OK** to first enter the folder, then **PLAY**, if you are in stop mode. If playback has already started, press **OK**. Playback stops when all the files have been played.

3. To exit a folder, use the arrow buttons to select the **<..>** then press **OK**.

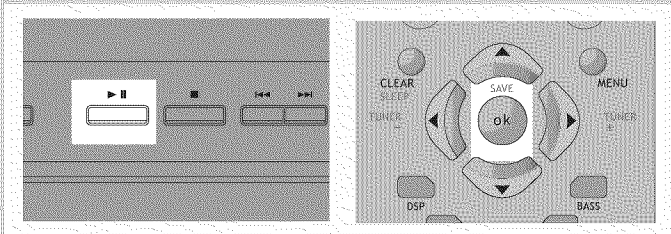

Playmode selection for mp3

1. You can select your desired playmode in mp3 menu.

- i. Standard - normal playback
- ii. Playlist - play your programmed tracks
- iii. Random - play tracks randomly
- iv. Track repeat - repeat desired track
- v. Folder repeat - repeat desired folder
- vi. Disc repeat - repeat the whole disc
- vii. Playlist repeat - repeat programmed tracks
- viii. Playlist random - play programmed tracks randomly



2. When the Play Mode window is highlighted and blinking, use the **Up** or **Down** arrow to toggle different play-modes, then press **OK** to confirm.

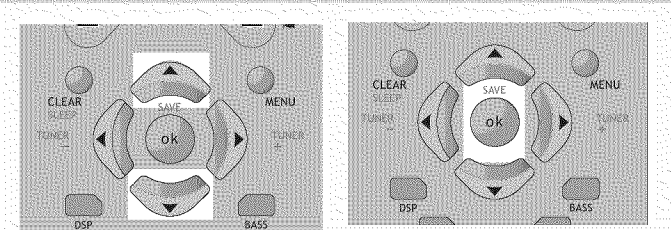

Playlist

1. In the playmode setting window, press the **UP** or **DOWN** arrow to select playlist mode.

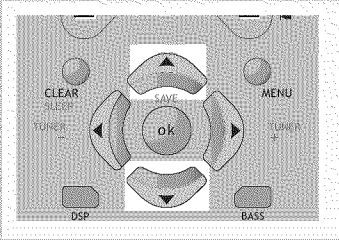

2. Use the **UP** and **DOWN** arrow on the remote to select on the left the files that you wish to add to the playlist

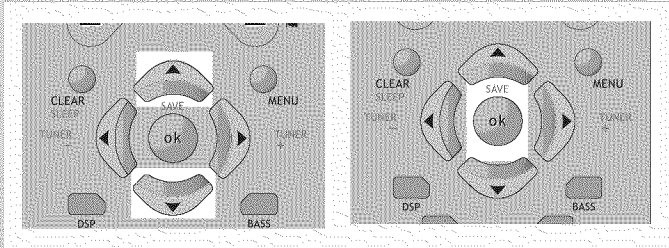

3. Press **OK** to move the file to the right of the playlist.

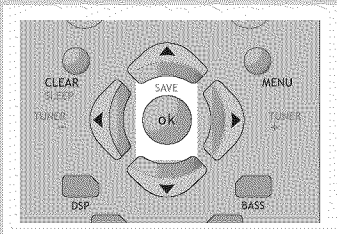

4. Once all the files have been selected, move the cursor to the file in the playlist and press **OK** to begin playlist playback.

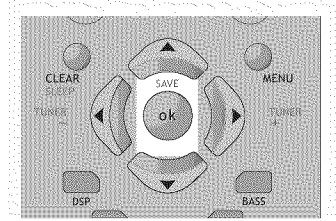

5. Press **STOP** to end playlist playback.

Delete a specific File from the Program List

1. Use the **LEFT** or **RIGHT** arrow to select program list, then use the **UP** or **DOWN** arrow to select file to be deleted and move to delete icon and press **OK** to delete.

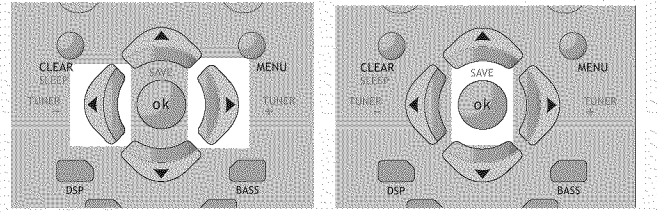

Delete All

1. In stop mode, use the **LEFT** or **RIGHT** arrow to select the "DELETE ALL" icon and press **OK** to clear all.

On- screen display for JPEG CD

File mode

1. In the JPEG mode window, use the **UP** or **DOWN** arrow to select a directory, and the **OK** button on the remote to enter different directories. You can use the **RETURN** button to go up one layer in the directory.

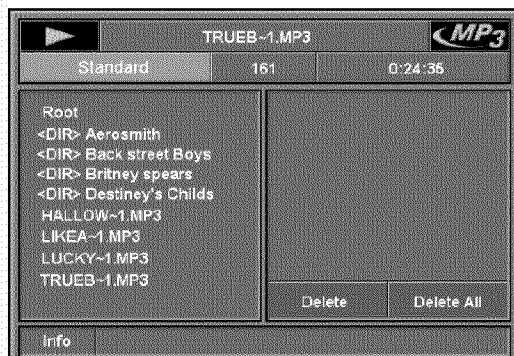

2. Use the **UP** or **DOWN** arrow buttons on the remote to select the file you wish to view.

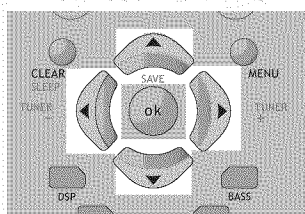

3. Press the **OK** button, and the picture you select will display on the screen.

4. When viewing the image, you can press the **CH+** or **CH-** button to skip to next / previous image.

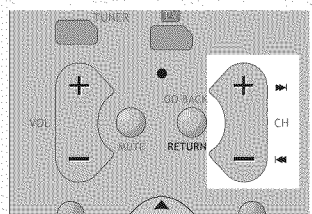

Zooming / rotating the image

1. In JPEG file mode, when you are viewing an image, you can rotate the image by pressing the **LEFT** or **RIGHT** arrow. (not working in ZOOM mode.)

2. You can also mirror the image either horizontally or vertically by pressing the **UP** or **DOWN** arrow. (not working in ZOOM mode.)

3. If you want to zoom in the image to full screen mode, just press the **ZOOM** button.

4. In ZOOM mode, you can pan the screen at any direction by pressing the corresponding navigation key.

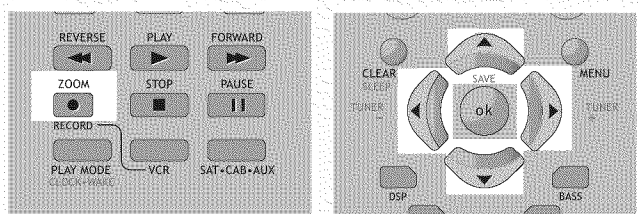

5. To return to normal mode, press the **ZOOM** or **STOP** button.

Note: The zooming function will not be available if your image pixels count is too low.

Slideshow mode

1. In JPEG mode, Press **PLAY/PAUSE** on the main unit or **PLAY** on the remote control to start the slideshow. Pictures will be shown on screen for 5 seconds and fade, playback will stop until all the files are played.

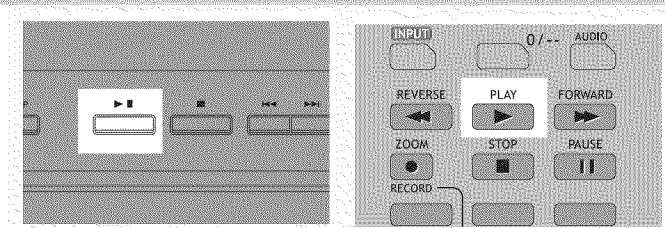

2. You can pause viewing by pressing the **PAUSE** button, or press the **PLAY** button to resume.

3. Press STOP button to go back to navigation mode.

Playmode

In JPEG mode, you can select different playmodes in the playmode selection field.

1. Random: randomly view JPEG files.
2. Repeat disc: view all images in the disc repeatedly.
3. Folder repeat: view all images in the folder repeatedly.

Mixed mode (when playing disc containing both mp3 and JPEG)

When reading a mixed disc, the unit will play the first mp3 (if any). However, as you navigate the disc, whenever the cursor stops at any JPEG file, the mp3 playback will stop, and a preview of that picture will shown on screen.

- When your cursor is on any mp3 file, press OK to start playback.
- When your cursor is on any JPEG file, press OK to start viewing.

Attention: The unit only supports .JPG. as a valid file extension

Operating the Radio

The receiver has a built-in tuner that allows for AM/FM radio function.

Manual tuning

1. Connect the FM and AM antenna accordingly (see "Connecting the Antenna" on page 5 section for details)
2. Press **ON/STANDBY** on the main unit or **ON/OFF** button on the remote.

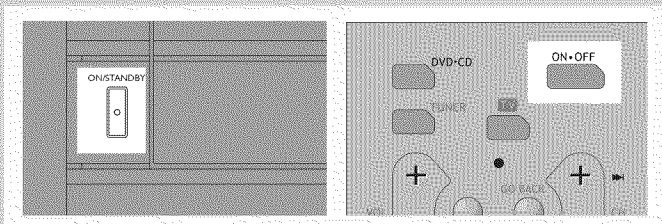

3. Press **SOURCE** on the front of the unit until the tuner mode is selected. You may also directly press **TUNER** on the remote control.

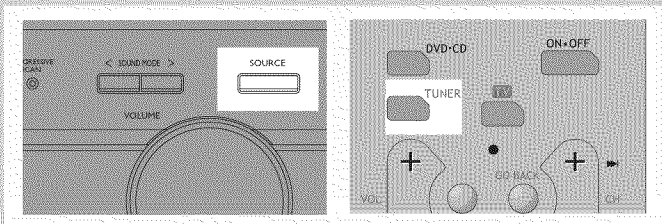

4. To select a band, you may press **TUNER** again on the remote control. You may also press the **BAND/AAP** button on the main unit. When an FM station broadcasts Stereo sound, ST is displayed.

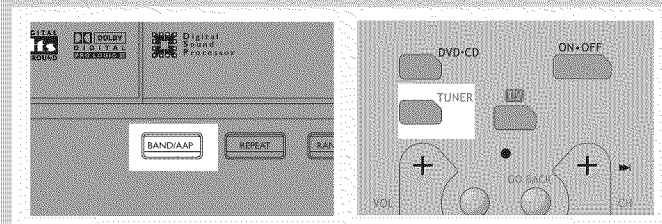

5. Tune to a station by pressing **TUNER +** or **TUNER -** on the remote control repeatedly until the desired station is found.

Alternatively, you can press and hold the same buttons for about one second to activate the automatic **SEARCH** function. In this mode the receiver will automatically tune frequencies until it finds a station.



6. Repeat steps 5 to tune to another radio station.

Select a sound effect if needed by pressing **DSP**.

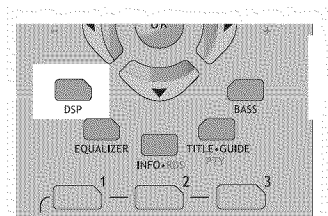

NOTE

1. If there is interference, modify the location of the antenna until the optimal sound is heard. TV and other electronic devices could be the cause of interferences so try to position the antenna away from them.

2. Weak signal can affect the "auto Search function". Adjust the antenna for a better reception and for a more efficient search.

Storing radio stations:

The receiver can store up to 40 radio stations in memory. You can enter every single radio station yourself or the receiver can store all available radio stations automatically in an ascending order.

Automatic preset storing :

1. Press **BAND/AAP** on the main unit or **TUNER** repeatedly on the remote control to select the FM band.

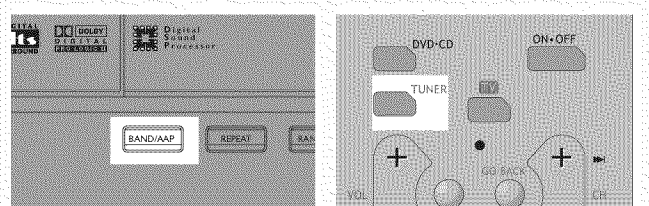

2- Press and hold **BAND/AAP** or **TUNER** button for 3 seconds to start the automatic preset programming. "PROG" will be flashing during the automatic storing process.

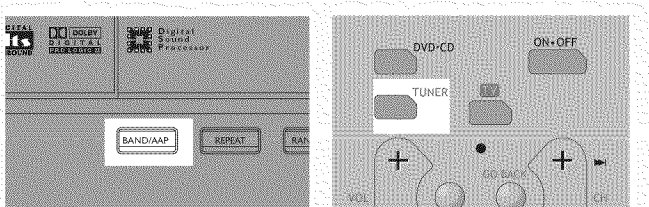

NOTE

A weak signal can affect the "Automatic Preset Storing function" efficiency. Adjust the antenna for a better reception and for a more efficient search. No APP function for AM mode.

Radio frequencies will be browsed and radio stations stored automatically. When all available radio stations are stored or if all 40 memory locations are full, the auto preset will stop.

Manual preset

1. Select the band by pressing **TUNER** repeatedly
2. Tune to a radio station (see "Manual tuning" on page 38 above for details)

3. Press **MENU** on the remote control. "PROG" will appear on the display

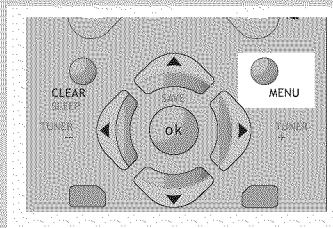

EN



4. While the word "PROG" is still flashing, input your desired preset number (1-40) using the numeric keys on the remote control to store the radio station.

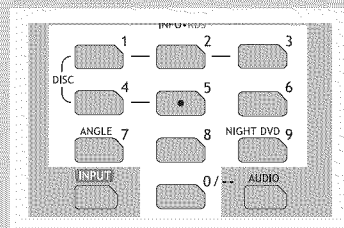

Retrieving preset stations

1. Press **SOURCE** on the unit or **TUNER** on the remote control to enter the tuner mode
2. Press **PRESET +** or **PRESET -** on the unit or **CH+** or **CH-** on the remote control to tune up or down preset channels.

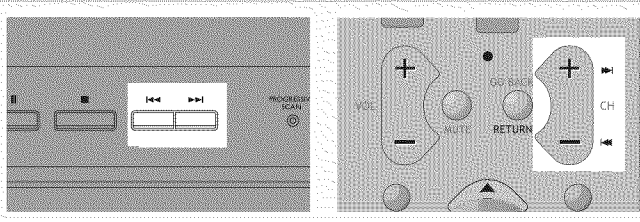

Troubleshooting Tips

Power

No power ?

- Correctly connect the AC Power Cord to an AC Outlet.

Power is switching off automatically ?

- If the player is not used, i.e. no key pressed for 30 minutes while in DVD/CD mode, it automatically switches to standby (Auto Power Off). Press the **ON/STANDBY** button to switch the player on again.

The keys do not activate the functions they control (unit and / or remote control).

- Set the ON/STANDBY key to OFF (red light on) and back to ON again. Alternatively, turn off the power, disconnect the power plug and then re-connect it (The player may not be operating properly due to lightning, static electricity or some other external factors).
- If keys still do not activate the functions they control even when the above mentioned corrective actions are taken, contact your RCA retailer.
- During protection such as OCP, OVP, OTP, the unit may already go into the "Latch mode", and the unit will need sometime to power on again. And the blue led will blink continuously for indication, you have to restart the unit by press the **ON/STANDBY** button on the main unit.

Video and audio

There is no picture ?

- Turn on the TV set.
- Check the connections.
- Make the correct input selection on the TV set.
- If progressive scan is turned on, there will be no picture coming out of the composite video and s-video outputs while in DVD/CD mode.

The picture is distorted or shakes during search, forward or reverse.

- Search, forward or reverse playback generates a slight distortion, but this is not a malfunction.

There is no sound or it can hardly be heard ?

- Make sure the speakers are connected.
- Make sure that the MUTE function is not on.
- Check the connections.
- Make the correct audio input selection and volume adjustment on the TV set or hifi system (e.g. AV selector).
- There is no sound during a pause (still picture), still picture advance, or slow playback.
- DTS may have been chosen as a default audio setting

No "Surround" sound ?

- Check the speaker configuration in the menu.

Noise interference appears on the TV, while watching a TV program and the DVD player is left on ?

- Turn off the DVD player.
- The TV is too close to the audio system.

Volume level differences playing different disc types (DVDs, audio / video CDs).

- Adjust the master volume .

No audio from one channel.

- Check the speaker level setting.
- Check the speaker wire or cable connections.

Remote control

The remote control does not work ?

- Load the batteries with their polarities (+ and -) aligned correctly.
- Batteries are low. Replace with new ones.
- Point the remote control to the front of the player.
- Operate the remote control within a 26 ft range from the player.
- Remove any obstacles between the remote control and the front display of the player.

The invalid icon appears on-screen ?

- If an invalid icon appears on-screen when a button is pressed, it is probably because :
 1. The DVD does not allow it.
 2. The DVD does not have this option /e.g., angles.
 3. The function is not available on that part of the disc.
 4. You have requested a title or chapter number or search time that is not available.

TV or video recorder cannot be operated with the remote control.

- Not all models can be operated with the supplied universal remote control.

No picture or the picture shown is not that of the DVD player.

- Switch off the other video device connected to the AV jack of the player.

Playback

Playback does not start when the PLAY key is pressed ?

- Make sure that the disc (single sided) is loaded correctly with the title label facing up.
- Make sure you are in the proper source mode.

Playback stops immediately after the PLAY key is pressed ?

- This player can play DVDs, Video CDs and Audio and MP3 CDs only, check that your disc corresponds to one of these formats.
- If the disc is dirty, wipe it with a soft and clean cloth.
- Condensation occurred inside the player. Leave it at room temperature for 1 to 2 hours.

Disc cannot be played.

- Wipe the disc clean.
- Use a RCA lens cleaner.
- The disc's region No. differs from your player's region No.

Search forward & reverse playback does not work ?

- Some DVDs have segments where search forward & reverse playback functions do not work.

Subtitle, language, camera angle etc.

Disc menu operation and contents may differ from disc to disc. Please refer to the instructions accompanying the disc.

There are no subtitles ?

- check that subtitles are supposed to exist on that disc.
- Subtitles disappear from the TV screen. See page 21 to display subtitles.

Subtitle (or language) setting cannot be changed ?

- The disc being played has been recorded in only one language.
- Depending on the type of DVD, some segments limit language selection.

The picture is not displayed in the correct format on the TV (4 x 3 or 16 x 9)

- According to your TV, make the correct "TV Screen" setting in the set-up menu (page 29).

The camera angle cannot be changed with the angle button ?

- This function does not work when a DVD has not been recorded with a multi-camera angle system. Some DVDs use a multi-camera angle system only in certain portions of the DVD.

The menu language is not the one you want ?

- The menu language for your player has not been set during set-up.
- Your preferred menu language on a DVD disc (if available) has not been set during set up.

Audio (spoken) and / or subtitle language is not the one selected during the initial player set-up ?

- If the audio or subtitle language is not available on the DVD disc, the language selected during initial player set-up will not be heard or seen. The disc's priority language (default language) is selected automatically. If you want another language, press menu during playback, if the disc has its own language selection menu (Refer to page 21).

Radio

STEREO indicator is off.

- Adjust the antenna.

The signal is Mono. Severe hum or noise.

- The signal is too weak. Connect an external antenna.

Equipment Specifications:

AMPLIFIER SECTION:

Stereo mode: each 60W at 6 ohm. 10% THD @1 kHz
Subwoofer channel: 120w at 12Ω
Muting Attenuation: >65dB
Frequency Response: 20Hz to 20kHz +/-1dB
Signal to Noise Ratio: 65dB (Bypass mode)

VIDEO SECTION:

Input (Sensitivity/ Impedance):1Vp-p/ 75ohm
Output (Level/ Impedance): 1Vp-p/ 75 ohm
Frequency Response: 10Hz to 6MHz at +/- 3dB
Signal to noise ratio: 40dB
Crosstalk @3.58MHz: 40dB

AM TUNER SECTION:

Frequency Response: 80Hz – 2kHz +/-6dB
Usable Sensitivity: 5000uV/m @ S/N 20dB
Signal to Noise: 30dB
Image Ratio: 20dB @ 1000kHz
IF Rejection: 35dB

FM TUNER SECTION:

Frequency Response: 40Hz – 15kHz +/-3dB
Quieting: 24dBu
Signal to Noise: 60dB(stereo) / 65dB(mono)
Image Ratio: 40dB
IF Rejection: 50dB

JPEG CD SECTION:

Supported format - JPEG

Dimensions (H x W x D inch) :

Unit - 4.4 x 17 x 15.7
Front speaker - 7.8 x 4.6 x 5.5
Rear speaker - 6.5 x 3.5 x 4.2
Center speaker - 4.5 x 9.5 x 4.7
Subwoofer - 14 x 7.7 x 13.8

Care and Maintenance

Disconnect the audio system from the power source before performing any maintenance.

Cleaning

Clean the exterior of the system using a soft dust cloth.

The player

CAUTION! This system operates with a laser. It must only be opened by a qualified technician.

- Never move the player during playback.
- Never put more than one disc on a tray or put a disc slipping out of the guide area.

Handling discs

- Do not touch the signal surfaces.
- Hold discs by the edges, or by one edge and the hole.
- Do not affix labels or adhesive tapes to the label surfaces.
- Do not scratch or damage the label. Discs rotate at high speeds inside the player.
- Do not use damaged (cracked or warped) discs.



Cleaning discs

- Dirty discs can cause poor sound and visual quality. Always keep discs clean by wiping them gently with a soft cloth from the inner edge toward the outer perimeter. Never wipe the disc in a circular motion since circular scratches are likely to occur and could cause noise during playback.
- If a disc becomes dirty, wet a soft cloth in water, wring it out well, wipe the dirt away gently, and then remove any water drops with a dry cloth.
- Do not use record cleaning sprays or antistatic agents on discs. Also, never clean discs with benzene, thinner, or other volatile solvents which may cause damage to disc surface.



Disc lens care

- When your disc lens gets dirty it can also cause the system to output poor sound and visual quality. To clean the lens you will need to purchase a disc lens cleaner which can maintain the output sound and visual quality of your system. For instructions on cleaning the disc lens, refer to the ones accompanying the lens cleaner.

Important battery information

- Remove the batteries to avoid leakage if you do not use your remote control for more than one month.
- Discard leaky batteries immediately as leaking batteries may cause skin burns or other personal injuries.
- Dispose of batteries in the proper manner, according to provincial and local regulations.
- Any battery may leak electrolyte if mixed with a different battery type, if inserted incorrectly, if all batteries are not replaced at the same time, if disposed of in fire, or if an attempt is made to charge a battery not intended to be recharged.

Transportation information

- Unplug the unit when the STANDBY LED is on while in STANDBY mode.

Safety precautions

- Never open the cabinet under any circumstances. Any repairs or internal adjustments should be made only by a trained technician.
- Never operate this product with the cabinet removed.
- Do not touch the player with wet hands. If any liquid enters the player cabinet, take the player to a trained technician for inspection.
- This player uses a laser to read the data on the disc. The laser mechanism corresponds to the cartridge and stylus of a record player. Although this product incorporates a laser pick-up lens, it is completely safe when operated according to directions.
- Discs rotate at high speed inside the player. Do not use damaged, warped, or cracked discs.
- Do not touch the pick-up lens which is located inside the disc compartment. Also, to keep dust from collecting on the pick-up lens do not leave the compartment door open for an extended period of time. If the lens becomes dirty, clean it with a soft brush, or use an air blower brush designed for camera lenses.
- The apparatus shall not be exposed to dripping or splashing and that no objects filled with liquids, such as vases, shall be placed on the apparatus.

Headset safety

- Do not play your headset while the sound is at high volume levels. Hearing experts warn against extended high-volume play.
- If you experience a ringing in your ears, reduce volume or discontinue use.
- You should use extreme caution or temporarily discontinue use in potentially hazardous situations.
- Even if your headset is an open-air type designed to let you hear outside sounds, don't turn up the volume so high that you are unable to hear what is around you.

Don't infringe

This product should only be used for the purposes for which it is sold, that is, entertainment, violating no copyright law. Any attempts to use this product for which it is not intended is unlawful and therefore not condoned by Thomson.

The descriptions and characteristics given in this document are given as a general indication and not as a guarantee. In order to provide the highest quality product possible, we reserve the right to make any improvement or modification without prior notice. The English version serves as the final reference on all products and operational details should any discrepancies arise in other languages.

TV CODES

Abex	1172
Admiral	1001, 1173, 1211
Adventura	1174
Aiko	1016
Akai	1002
Alleron	1046
Amtron	1038
Anam National	1003, 1038, 1192, 1193, 1194
AOC	1004, 1005, 1006, 1007, 1175, 1176, 1195
Audiovox	1038
Belcor	1004
Bell & Howell	1001, 1083, 1162
Bradford	1038
Brokwood	1004
Candle	1004, 1006, 1008, 1174
Celebrity	1002
Centurion	1009
Citizen	1004, 1006, 1008, 1016, 1038, 1105, 1171, 1174, 1177
Colortyme	1004, 1006, 1010
Concerto	1004, 1006
Contec/Cony	1012, 1013, 1014, 1038
Craig	1038
Crown	1038, 1171
Curtis Mathes	1000, 1004, 1006, 1015, 1105, 1162, 1171, 1212
CXC	1038
Daewoo	1004, 1005, 1006, 1016, 1017, 1018, 1127, 1171, 1196
Daytron	1004, 1006, 1171
Dimensia	1000
Dumont	1004, 1151
Electroband	1002
Electrohome	1003, 1004, 1006, 1019, 1020, 1022
Emerson	1004, 1006, 1012, 1023, 1024, 1025, 1026, 1027, 1028, 1029, 1030, 1031, 1032, 1033, 1034, 1035, 1036, 1037, 1038, 1039, 1041, 1042, 1043, 1044, 1046, 1047, 1123, 1124, 1162, 1163, 1171, 1177, 1179, 1191, 1208
Envision	1004, 1006
Fisher	1048, 1049, 1051, 1162, 1180
Fujitso	1046
Funai	1038, 1046
Futuretec	1038
GE	1000, 1003, 1004, 1006, 1022, 1052, 1054, 1055, 1087, 1164, 1165, 1166, 1167, 1168, 1181, 1213
Gibraltar	1004, 1151
Goldstar	1004, 1005, 1006, 1012, 1019, 1056, 1057, 1058, 1155, 1156, 1171, 1172
Grundy	1038, 1046, 1171
Hallmark	1004, 1006
Harvard	1038
Hitachi	1004, 1006, 1012, 1013, 1014, 1059, 1060, 1061, 1135, 1136, 1137, 1138, 1139, 1140, 1141, 1142, 1143, 1144, 1145, 1146, 1148, 1150, 1179, 1198, 1199

IMA	1038
Infinity	1062
JCPenney	1000, 1004, 1005, 1006, 1008, 1022, 1052, 1054, 1058, 1063, 1064, 1072, 1087, 1105, 1128, 1171, 1172, 1181, 1201
Janeil	1174
JBL	1062
JCB	1002
Jensen	1004, 1006
JVC	1012, 1013, 1014, 1054, 1060, 1065, 1066, 1067, 1157, 1158, 1159, 1182
Kawasho	1002, 1004, 1006
Kenwood	1004, 1006, 1019
Kloss Novabeam	1068, 1069, 1174, 1183
KTV	1038, 1070, 1171, 1177
Loewe	1062
Logik	1083
Luxman	1004, 1006
LXI	1000, 1006, 1049, 1062, 1071, 1072, 1073, 1162, 1181, 1207
Magnavox	1004, 1006, 1008, 1019, 1062, 1068, 1069, 1075, 1076, 1077, 1088, 1130, 1131, 1132, 1133, 1134, 1183, 1219, 1235
Majestic	1083
Marants	1062
Marantz	1004, 1006, 1062, 1078
Megatron	1006, 1059
Memorex	1001, 1006, 1082, 1083, 1162
MGA	1004, 1005, 1006, 1019, 1022, 1051, 1079, 1080, 1082
Midland	1054, 1151, 1171, 1172, 1181
Minutz	1052
Mitsubishi	1004, 1005, 1006, 1019, 1022, 1051, 1079, 1080, 1081, 1082, 1125
Montgomery Ward	1083
Motorola	1003, 1173
MTC	1004, 1005, 1006, 1105
Multitech	1038
Multivision	1084
NAD	1006, 1071, 1072, 1185
NEC	1003, 1004, 1005, 1006, 1200
Nikko	1006, 1016
NTC	1016
Onwa	1038
Optimus	1185
Optonica	1095, 1173
Orion	1035, 1191
Panasonic	1003, 1054, 1062, 1170, 1214
Philco	1003, 1004, 1005, 1006, 1008, 1012, 1019, 1062, 1068, 1069, 1075, 1077, 1183
Phillips	1003, 1004, 1008, 1012, 1019, 1062, 1068, 1069, 1075, 1076, 1086, 1087, 1088, 1089
Pilot	1004, 1171
Pioneer	1004, 1006, 1090, 1091, 1092, 1179, 1185
Portland	1004, 1005, 1006, 1016, 1171
Price Club	1105
Prism	1054
Proscan	1000, 1181
Proton	1004, 1006, 1012, 1093
Pulsar	1004, 1151
Quasar	1003, 1054, 1070, 1094

Remote Codes

Radio Shack/Realistic	1000, 1004, 1006, 1012, 1038, 1049, 1095, 1162, 1171, 1172
RCA	1000, 1003, 1004, 1005, 1006, 1007, 1019, 1096, 1098, 1099, 1100, 1101, 1102, 1103, 1129, 1179, 1181, 1187, 1188, 1190, 1202, 1203, 1215, 1233
Runco	1151
Sampo	1004, 1006, 1171, 1172
Samsung	1004, 1005, 1006, 1012, 1015, 1019, 1104, 1105, 1106, 1171, 1172, 1204
Samsux	1171
Sansui	1191
Sanyo	1004, 1048, 1049, 1080, 1107, 1108, 1162, 1169, 1180
Scotch	1006
Scott	1004, 1006, 1012, 1024, 1035, 1038, 1046
Sears	1000, 1004, 1006, 1013, 1014, 1019, 1046, 1048, 1049, 1051, 1066, 1071, 1072, 1109, 1110, 1162, 1180, 1181, 1189
Sharp	1004, 1006, 1012, 1029, 1095, 1111, 1112, 1113, 1122, 1171, 1173
Shogun	1004
Signature	1001, 1083, 1115
Simpson	1008
Sony	1002, 1205, 1216, 1218
Soundesign	1004, 1006, 1008, 1038, 1046
Squareview	1189
SSS	1004, 1038
Starlite	1038
Supre-Macy	1174
Supreme	1002
Sylvania	1004, 1006, 1008, 1019, 1062, 1068, 1069, 1075, 1076, 1077, 1088, 1116, 1161, 1183
Symphonic	1033, 1038, 1189
Tandy	1173
Tatung	1003
Technics	1054
Techwood	1004, 1006, 1054
Teknika	1004, 1005, 1006, 1008, 1012, 1013, 1014, 1016, 1038, 1046, 1076, 1082, 1083, 1105, 1170, 1171
Telecaption	1117
TMK	1004, 1006
Toshiba	1049, 1071, 1072, 1105, 1109, 1117, 1118, 1160, 1162
Totevision	1171
Universal	1052, 1087
Victor	1066, 1182
Vidtech	1004, 1005, 1006
Viking	1174
Wards	1000, 1001, 1004, 1005, 1006, 1019, 1024, 1033, 1046, 1052, 1062, 1068, 1069, 1075, 1076, 1083, 1087, 1088, 1095, 1119, 1120
Yamaha	1004, 1005, 1006, 1019
Zenith	1004, 1083, 1151, 1152, 1153, 1154, 1210, 1217

For audio track and subtitle selection, see p.25,26.

Abkhazian	6566	Kashmiri	7583	Tatar	8484
Afar	6566	Kazakh	7575	Telugu	8469
Afrikaans	6570	Kanyarwanda	8287	Thai	8472
Albanian	8381	Kirghiz	7589	Tibetan	6679
Amehanie	6577	Kirundi	8278	Tigrinya	8473
Arabic	6582	Korean	7579	Tonga	8479
Armenian	7289	Kurdish	7585	Tsonga	8483
Assamese	6583	Laothian	7679	Turkish	8482
Aymara	6588	Latin	7665	Turkmen	8475
Azerbaijani	6590	Latvian, Leltish	7684	Twi	8487
Bashkir	6665	Lingala	7678	Ukrainian	8575
Basque	6985	Lithuanian	7684	Urdu	8582
Bengali, Bangla	6678	Macedonian	7775	Uzbek	8590
Bhutani	6890	Malagasy	7771	Vietnamese	8673
Bihari	6672	Malay	7783	Volapuk	8679
Bislama	6673	Malayalam	7776	Welsh	6789
Breton	6682	Maltese	7784	Wolaf	8779
Bulgarian	6671	Maori	7773	Xhosa	8872
Burmese	7789	Marathi	7782	Yiddish	7473
Byelorussian	6669	Moldavian	7779	Yoruba	8979
Cambodian	7577	Mongolian	7778	Zulu	9085
Catalan	6765	Naru	7865		
Chinese	9072	Nepali	7869		
Corsican	6779	Norwegian	7879		
Croatian	7282	Occitan	7967		
Czech	6783	Oriya	7982		
Danish	6865	Oroma (Atan)	7977		
Dutch	7876	Punjabi	8065		
English	6978	Pashto, Pushao	8083		
Esperanto	6979	Persian	7065		
Estonian	6984	Polish	8075		
Faeroese	7079	Portuguese	8084		
Fiji	7074	Quechua	8185		
Finnish	7073	Ahaero- Romance	8277		
French	7082	Romanian	8279		
Frisian	7089	Russian	8285		
Galiean	7176	Samoan	8377		
Georgian	7565	Sangbo	8371		
German	6869	Sanskrit	8365		
Greek	6976	Sents Gaelic	7168		
Greenland	7576	Serbian	8382		
Guarani	7178	Servo-Croatian	8372		
Gujarati	7185	Sesotho	8384		
Hausa	7265	Setswana	8478		
Hebrew	7387	Sindhi	8368		
Hindi	7273	Singhalese	8373		
Hungarian	7285	Siswati	8383		
Icelandic	7383	Slovak	8375		
Indonesian	7378	Slovenian	8376		
Interlingua	7365	Somali	8379		
Interlingue	7369	Spanish	6983		
Inupiaic	7375	Sudanese	8385		
Irish	7165	Swahili	8387		
Italian	7384	Swedish	8386		
Japanese	7465	Tagalog	8476		
Javanese	7487	Tajik	8471		
Kannada	7578	Tamil	8465		

Limited Warranty (U.S.)

What your warranty covers:

- Defects in materials or workmanship.

For how long after your purchase:

- One year from date of purchase for labor and parts
- The warranty period for rental units begins with the first rental or 45 days from date of shipment to the rental firm, whichever comes first.

What we will do:

- Pay any Authorized RCA Audio Service Center the labor charges to repair your unit.
- Pay any Authorized RCA Audio Service Center for the new or, at our option, refurbished replacement parts required to repair your unit.

How you get service:

- Take your unit to any Authorized RCA Audio Service Center. To identify your nearest Authorized RCA Audio Service Center, ask your dealer, look in the Yellow Pages, or call 1-800-336-1900.
- Show the Authorized Service Center Representative your evidence of purchase date or first rental.
- Pick up your unit when repairs are completed.
- Proof of purchase in the form of a bill of sale or receipted invoice which is evidence that the product is within the warranty period must be presented to obtain warranty service. For rental firms, proof of first rental is also required.

What your warranty does not cover:

- Customer instruction. (Your Owner's Manual describes how to install, adjust, and operate your unit. Any additional information should be obtained from your dealer.)
- Installation and related adjustments.
- Signal reception problems not caused by your unit.
- Damage from misuse or neglect.
- Cleaning of audio heads.
- Batteries.
- A unit that has been modified or incorporated into other products or is used for institutional or other commercial purposes.
- A unit purchased or serviced outside the U.S.A.
- Acts of nature, such as but not limited to lightning damage.

Product Registration:

- Please complete and mail the Product Registration Card packed with your product. It will make it easier to contact you should it ever be necessary. The return of the card is not required for warranty coverage.

Limitation of Warranty:

- THE WARRANTY STATED ABOVE IS THE ONLY WARRANTY APPLICABLE TO THIS PRODUCT. ALL OTHER WARRANTIES, EXPRESS OR IMPLIED (INCLUDING ALL IMPLIED WARRANTIES OF MERCHANTABILITY OR FITNESS FOR A PARTICULAR PURPOSE) ARE HEREBY DISCLAIMED. NO VERBAL OR WRITTEN INFORMATION GIVEN BY THOMSON INC., ITS AGENTS OR EMPLOYEES SHALL CREATE A WARRANTY OR IN ANY WAY INCREASE THE SCOPE OF THIS WARRANTY.
- REPAIR OR REPLACEMENT AS PROVIDED UNDER THIS WARRANTY IS THE EXCLUSIVE REMEDY OF THE CONSUMER. THOMSON INC. SHALL NOT BE LIABLE FOR INCIDENTAL OR CONSEQUENTIAL DAMAGES RESULTING FROM THE USE OF THIS PRODUCT OR ARISING OUT OF ANY BREACH OF ANY EXPRESS OR IMPLIED WARRANTY ON THIS PRODUCT. THIS DISCLAIMER OF WARRANTIES AND LIMITED WARRANTY ARE GOVERNED BY THE LAWS OF THE STATE OF INDIANA. EXCEPT TO THE EXTENT PROHIBITED BY APPLICABLE LAW, ANY IMPLIED WARRANTY OF MERCHANTABILITY OR FITNESS FOR A PARTICULAR PURPOSE ON THIS PRODUCT IS LIMITED TO THE APPLICABLE WARRANTY PERIOD SET FORTH ABOVE.

How State Law relates to warranty:

- Some states do not allow the exclusion nor limitation of incidental or consequential damages, or limitations on how long an implied warranty lasts, so the above limitations or exclusions may not apply to you.
- This warranty gives you specific legal rights, and you also may have other rights that vary from state to state.

If you purchased your unit outside the United States:

- This warranty does not apply. Contact your dealer for warranty information.

Service calls which do not involve defective materials or workmanship are not covered by this warranty. Costs of such service calls are the sole responsibility of the purchaser.

What your warranty covers:

- Defects in materials or workmanship.

For how long after your purchase:

- One year from date of purchase for labor and parts
- The warranty period for rental units begins with the first rental or 45 days from date of shipment to the rental firm, whichever comes first.

What we will do:

- Pay any Authorized RCA Audio Service Center the labor charges to repair your unit.
- Pay any Authorized RCA Audio Service Center for the new or, at our option, refurbished replacement parts required to repair your unit.

How you get service:

- Take your unit to any Authorized RCA Audio Service Center. To identify your nearest Authorized RCA Audio Service Center, ask your dealer, look in the Yellow Pages, or call 1-800-336-1900 / 1-866-723-6486.
- Show the Authorized Service Center Representative your evidence of purchase date or first rental.
- Pick up your unit when repairs are completed.
- Proof of purchase in the form of a bill of sale or receipted invoice which is evidence that the product is within the warranty period must be presented to obtain warranty service. For rental firms, proof of first rental is also required.

What your warranty does not cover:

- Customer instruction. (Your Owner's Manual describes how to install, adjust, and operate your unit. Any additional information should be obtained from your dealer.)
- Installation and related adjustments.
- Signal reception problems not caused by your unit.
- Damage from misuse or neglect.
- Cleaning of audio heads.
- Batteries.
- A unit that has been modified or incorporated into other products or is used for institutional or other commercial purposes.
- A unit purchased or serviced outside Canada.
- Acts of nature, such as but not limited to lightning damage.

Product Registration:

- Please complete and mail the Product Registration Card packed with your product. It will make it easier to contact you should it ever be necessary. The return of the card is not required for warranty coverage.

Limitation of Warranty:

• **THE WARRANTY STATED ABOVE IS THE ONLY WARRANTY APPLICABLE TO THIS PRODUCT. NO VERBAL OR WRITTEN INFORMATION GIVEN BY THOMSON MULTIMEDIA LTD., ITS AGENTS OR EMPLOYEES SHALL CREATE A GUARANTY OR IN ANY WAY INCREASE THE SCOPE OF THIS WARRANTY.**

• **REPAIR OR REPLACEMENT AS PROVIDED UNDER THIS WARRANTY IS THE EXCLUSIVE REMEDY OF THE CONSUMER. THOMSON MULTIMEDIA LTD. SHALL NOT BE LIABLE FOR INCIDENTAL OR CONSEQUENTIAL DAMAGES RESULTING FROM THE USE OF THIS PRODUCT. EXCEPT TO THE EXTENT PROHIBITED BY APPLICABLE PROVINCIAL LAW, ANY IMPLIED WARRANTY OF MERCHANTABILITY OR FITNESS FOR A PARTICULAR PURPOSE ON THIS PRODUCT IS LIMITED TO THE APPLICABLE WARRANTY PERIOD SET FORTH ABOVE.**

How Provincial Laws relates to warranty:

- This warranty gives you specific legal rights which are in addition to statutory warranties that may vary from Province to Province.

If you purchased your unit outside Canada:

- This warranty does not apply. Contact your dealer for warranty information.

Service calls which do not involve defective materials or workmanship are not covered by this warranty. Costs of such service calls are the sole responsibility of the purchaser.

FCC Information

Limited Warranty (Mexico)



Centro de Servicios Autorizados Express (servicio en 24 horas)

México, D.F.
Digital Service
Av. 3 A No. 12, Local 2
Col. Santa Rosa
México, D.F.
Tel. 01 53889621
55877599
55878971
55673972

Monterrey, N.L.
Audio Estéreo Aguilar
Gral. Zuazua 738 Nte.
Col. Centro
Monterrey, N.L.
Tel. 01 (8) 3724989
3755440
3755884

Guadalajara, Jal.
Servicio Especializado de Jalisco
Enrique Díaz de León No. 821
Col. Sagrada Familia
Guadalajara, Jal.
Tel. 01 (3) 1267431
1267430
8253229
82582

AGUASCALIENTES

Electrónica JIMSA
Av. Adolfo López Mateos No. 230 ote.
Col. Centro
Aguascalientes, Ags. C.P.
Tel. (01-49) 15 51 81 / 78 07 57
Fax. (01-49) 15 81 00

BAJA CALIFORNIA NORTE

Electrónica General Internac
Blvd. Insurgentes No. 16174, Loc. 2A
Tapachula, Chis.
Plaza de Abastos Los Almos
Tijuana, BCN C.P. 22440
Tel. (01-66) 21 22 15
Tel. / Fax. (01-66) 21 22 15

Baja Electronics

Hacienda de Corralejo No. 2099
Col. Hidalgo
Mexicali, B.C.N. C.P. 21389
Tel. (01-65) 619818, 619808
Fax. (01-65) 619808, 619818

Serv. Electrónico Ensenada

Calle 4ta No. 1050, Local B
Col. Centro
Ensenada, B.C.N. C.P. 22800
Tel. (01-61) 740 0532
Fax. (01-61) 788356

BAJA CALIFORNIA SUR

Digital Sound
16 de Septiembre No. 390
Col. Centro
La Paz, Baja California Sur
Tel. (112) 32017
Fax. (112) 32017

Video Servicio Beluz

Carretera a todos Santos No. 32
Col. Infonavit Las Brisas
Los Cabos san Lucas, BCS C.P. 23410
Tels. (01-114) 313 65
Fax. (01-114) 313 65

CAMPECHE

Videoservicio
Av. López Mateos No. 24
Col. Barrio Sn. Roman, C.P. 24040
Campeche, Camp.
Tel. (01-981) 6-3333
Fax. (01-981) 1-0664

CHIAPAS

KC Video
10a. Norte Oriente No. 153A
Col. Centro
Tuxtla Gutiérrez, Chis. C.P. 29000
Tel. (01-961) 8 19 08; 8 36 43
Fax. (01-961) 8 19 08

Serv. Elec. Especializado

Cuahutemoc No. 2A
Col. Centro, C.P. 29200
San. Cristóbal de las Casas, Chis.
Tel./Fax. (01-967) 8-1355
Fax. (01-967) 8-1355

Ele Aplicada Serv Digitales

4a. Av. Sur No. 51
Col. Centro, C.P. 30700
Tapachula, Chis.
Tel. (01-962) 6-9998
Fax. (01-962) 5-4578

CHIHUAHUA

Zener Electrónica
Trasviña y Retes No. 3503A
Col. Sn. Felipe
Chihuahua, Chih. C.P. 31240
Tels. (01-14) 14 01 16; 26 50 41
Tel. / Fax. (01-14) 26 50 41

Magnavox

Tlaxcala 1161
Col. Hidalgo
Cd. Juárez, Chihuahua, C.P. 32010
Tel. (01-16) 12 40 31
Fax. (01-16) 12 40 31

Electronica Tony

Priv. De la calle 6ta oriente No. 7
Col. Centro
Cd. Delicias, Chihuahua
Tel. (01-14) 74 30 26
Fax. (01-14) 74 30 26

Taller Electrónico Tony

20 de Noviembre No. 1521
Col. Centro
Cd. Camargo, Chihuahua, C.P.
Tel. (146) 234 67
Fax. (146) 234 67

COAHUILA

Electrónica Profesional
Blvd. Francisco Coss No. 450-1
Col. Centro
Saltillo, Coah C.P. 25000
Tels. (01-84) 10 03 00
Tel. / Fax. (01-84) 12 30 44

Audio y Video Electronica

Miguel Blanco 307-A
Col Zona Centro
Monclova, Coahuila, C.P. 25700
Tel. (01-86) 33 94 06
Fax. (01-86) 33 94 06

Electro Visión

Juan Aldama No. 6 y Presid. Carranza
Col. Centro
Nueva Rosita, Coahuila, C.P.
Tel. (86) 14 58 44
Fax. (86) 14 58 44

Electronica Rico

Iturbide y Manuel Acuña
Col. Centro
Cd. Acuña, Coahuila, C.P. 26250
Tel. (877) 236 23

Vacom

Av. Morelos 1016 ote.
Col. Centro
Torreón, Coah. C.P. 27000
Tel. (01-17) 18 39 05, 22 15 51
Fax. (01-17) 18 11 98

Electro Vision

Allende No. 114 esq. Xicotencatl
Zona Centro
Piedras Negras, Coahuila, C.P.
Tel. (878) 21875
Fax. (878) 21875

Multiservicios del Norte

5 de Mayo, 295 sur
Col. Centro
Sabinas, Coahuila, C.P. 26700
Tel. (861) 264 31
Fax. (861) 264 31

COLIMA

Elec. Saturno de Colima
Nigromante No. 138
Col. Centro
Colima, Col. C.P. 28000
Tel. (01-331) 4 55 54, 4 50 00
Tel. / Fax. (01-331) 4 55 54

Lab. Elect. De la Mora

Allende No. 110
Col. Centro
Manzanillo, Col. C.P. 28200
Tel. (01-333) 2 30 04
Tel. / Fax. (01-333)

DISTRITO FEDERAL

SIMEL
Río Churubusco No. 2215
Col. Agrícola Oriental
México, D.F. C.P. 08500
Tel. 756 0883
Fax. 756 0883

Novatron.

Diag. San Antonio No. 1213
Col. Narvarte
México, D.F. C.P. 03020
Tel. 639 0812
Fax: 639 1184

Electrónica Rangel.

San Felipe No. 157
Col. Pedregal de Santa Ursula
México D.F. C.P. 04800
Tel. 619 3213
Fax: 619 4565

DURANGO

MacroserVICIOS.
Calle Patoni No. 105 sur
Col. Centro
Durango, Dgo.
Tel. (01-18) 12 26 86
Fax. (01-18) 12 26 86

ESTADO DE MEXICO

Electrónica Alcántara.
Reforma No. 36
Col. Centro
Chalco, Edo. de Mex. C.P. 56600
Tel. (01-597) 51 847
Fax. (01-597) 51 847

Ctro Serv. Electrónicos

L. Portillo, esq. Blvd. Coacalco
Col. Villa de las Flores
Coacalco, Edo. de Mex. C.P. 55710
Tels: 879 3404; 874 6006
Fax: 898 2464

SHUREE Electrónica

Av. De los Maestros No. 113A
Col. Centro, C.P. 50060
Toluca, EDM.
Tel. (01-72) 14-9330
Fax. (01-72) 13-3424

TV Servideo

Oriente 9 No. 182
Col. Reforma
Cd. Neza, Edo. de Mex. C.P. 57840
Tel. 5857 2547
Fax. 5857 6399

Servicio Sony Visión

Prensa No. 1253
Col. Prensa Nal. Ind. Vallejo
Tlanepantla, E.D.M. C.P. 54170
Tel. 587 75 99
Fax: 587 89 71

GUANAJUATO

Tecnología Electrónica
Blvd. Adolfo López Mateos No. 2834A
Col. Haciendas El Rosario
León, Gto. C.P. 37130
Tel. (01 4) 773 6634
Fax. (01 4) 773 6634

Mar Electronic's

Brisas No. 999
Col. Las Reinas, C.P. 36660
Irapuato, Gto.
Tel. (01-462) 4-7140
Fax. (01-462) 4-7140

Tele Servicio Chucho.

Blv Adolfo López Mateos No 510 Pte
Col. Centro, C.P. 38000
Celaya, Gto.
Tel. (01-461) 2-4714
Fax. (01-461) 3-0591

Tele Radio Ortega.

Av. 16 de Septiembre No. 1076
Col. Centro, C.P. 38600
Acambaro, Gto.
Tel. (01-417) 2-0780
Fax. (01-417) 2-0780

Limited Warranty (Mexico)

GUERRERO

Nueva Elec. Auditron
Aquiles Serdan No. 14B
Col. Centro
Acapulco, Gro. C.P. 039300
Tels. (01-74) 82 62 42
Tel. / Fax: (01-74) 83 20 62

HIDALGO

Tec. Electrónica Digital
Blvd. Valle de San. Javier No.
Col. Fracc. Valle de San. Javier
Pachuca, Hgo. C.P. 42086
Tel. (01-771) 3 24 36
Tel. / Fax: (01-771) 3 24 36

Electrónica Especializada
Independencia No. 102 Loc. C
Col. Centro, C.P. 43600
Tulancingo, Hgo.
Tel. (01-775) 5-2654 3-9120
Fax. (01-775) 5-2654 3-9120

JALISCO

Serv. Esp. De Jalisco
Ignacio Ramirez No. 567
S.H. Sta. Teresita
Guadalajara, Jal. C.P. 44200
Tels. (01-3) 825-3229, 827-0721
Tel. / Fax: (01-3) 825-3229

Electrónica Integral

Candelaria No. 202, Esq. Analco
Col. Sta. Maria
Puerto Vallarta, Jal. C.P. 48348
Tels. (01-322) 4 37 36
Tel. / Fax: (01-322) 4 85 90

Setesa

5 de Febrero No. 2786
Col. Rancho Blanco
Tlaquepaque, Jalisco. C.P. 44890
Tel. (01-3) 635-4404, 635-1875
Fax. (01-3) 635-4404, 635-1875

MICHOACAN

Alka Electrónica
García de León No. 271
Col. Chapultepec Sur.
Morelia, Mich. C.P. 58260
Tels. (01-43) 14 55 21; 15 90 36
Tel. / Fax: (01-43) 15 94 25

Centro Electrónico Sony

Justo Mendoza No. 12
Col. Centro
Uruapan, Mich. C.P. 60000
Tels. (01-452) 4 37 78; 4 08 38
Tel. / Fax: (01-452) 4 59 09

Multiserv Prof. Zamora

5 de Mayo No. 699A
Col. El Duero
Zamora, Mich. C.P. 59690
Tel. (01-351) 5 54 16
Tel. / Fax: (01-351) 5 54 16

MORELOS

Electrónica Hertz
Insurgentes No. 190
Col. Emiliano Zapata
Cuautla, Mor. C.P. 62744
Tel. (01-735) 3 84 10
Fax. (01-735) 3 84 10

Electrónica Hertz

Libertad No. 108
Col. La Carolina
Cuernavaca, Mor. C.P. 62190
Tel. (01-73) 13 90 92
Fax. (01-73) 13 09 49

NUEVO LEÓN

Audio Estereo Aguilar
Gral. Zuazua 738 Nte.
Col. Centro
Monterrey, Nvo. León. CP. 64000
Tels. (01-8) 372-4989 / 375-5440
Tel. / Fax: (01-8) 375-5884

Teleservicio Murillo

Allende No. 595 Sur.
Col. Centro
Cd. Linares, Nvo León. C.P. 67700
Tel. (01-821) 266 50
Fax. (01-821) 266 50

NAYARIT

Electrónica Show
San Luis No. 118 sur
Col. Centro
Tepic, Nay. C.P. 63000
Tel. (01-321) 4 58 00
Tel. / Fax: (01-321) 4 58 00

OAXACA

El Franciscor
Húsares No. 207
Col. Centro
Oaxaca, Oax. C.P. 68000
Tel. (01-951) 6 47 37
Fax. (01-951) 472 97

PUEBLA

Serv. Express Electrónico
Prof. Reforma No. 6908A
Col. La Libertad
Puebla, Pue. C.P. 72130
Tels. (01-22) 49 78 19; 37 02 82
Tel. / Fax: (01-22) 31 32 93

QUERETARO

Blafuon Industrial
Av. Universidad No. 44B
Col. Pathe
Querétaro, Qro. C.P. 76020
Tels. (01-42) 23 22 66; 23 49 34
Tel. / Fax: (01-42) 23 22 67

QUINTANA ROO

Electrónica Beta
Av. Sun Yax Chen No. 43 Loc. 4
Col. Centro
Cancun, Q. Roo. C.P. 77508
Tel. (01-98) 84 54 12
Fax. (01-98) 87 38 13

Electronicos y Mas

Ignacio Zaragoza No. 204-A
Col. Centro, C.P. 77000
Chetumal, Q. Roo
Tel. (983) 26663, 24622, 21562
Fax. (983) 26014

SAN LUIS POTOSI

Electrónica Especializada
Manuel J. Clouthier No. 212C
Col. Las aguilas
San Luis Potosi, SLP. C.P. 78270
Tels. (01-48) 17 62 79
Tel. / Fax: (01-48) 14 19 02

Estereo Car

Negrete No. 612
Col. Centro
Cd. Valles, SLP. C.P. 79000
Tel. (01-138) 206 51
Fax. (01-138) 206 51

SINALOA

Serv. Electrónico del Pacifico
Mariano Escobedo No. 1022
Col. Centro
Mazatlán, Sin. C.P. 82000
Tel. (01-69) 82 01 55
Tel. / Fax: (01-69) 82 01 55

Reparaciones Electrónicas

J. Jose Ríos No. 178 ote.
Col. Centro.
Culiacan Sinaloa. C.P. 81200
Tel. (01-67) 16 81 32, 16 51 45
Fax. (01-67) 16 81 32, 16 51 45

Electrónica Morelos.

Morelos No. 201 ote
Col. Centro.
Los Mochis, Sinaloa. C.P. 81200
Tel. (01-68) 12 05 88
Fax. (01-68) 12 05 88

SONORA

Wong's Electrónicos
Monteverde No. 267 esq. Balderrama
Col. Balderrama
Hermosillo, Son. C.P. 83180
Tels. (01-62) 10 54 95; 10 05 86
Tel. / Fax: (01-62) 10 54 95

Dasetronik.

Guerrero No. 308-A este.
Col. Centro.
Navojoa, Sonora. C.P. 85800
Tel. (01-642) 240 64,
Fax. (01-642) 136 64

Audio video Electrónica

Av. Zaragoza No. 516 pte.
Col. Centro.
Cd. Obregon, Sonora. C.P. 23000
Tel. (01-64) 14 38 28
Fax. (14 75 75)

Electrónica Universal.

Calle 29 Av. Alfonso Idberry No. 401
Col. Centro
Cd. Guaymas, Sonora. C.P. 85400
Tel. (01-622) 29 411

Electronica Castillo

Noche Buena # 37
Col. El rastro
Nogales, Sonora. C.P. 84000
Tel. (16) 314 6857
Fax. (16) 312 3087

TABASCO

Elec. Sigma de Tabasco
Av. Gregorio Méndez No. 2819
Col. Atasta
Villahermosa, Tab. C.P. 86100
Tels. (01-93) 54 00 33; 54 20 30
Tel. / Fax: (01-93) 54 00 33

TAMAULIPAS

Electrónica Digital
Independencia No. 112 esq. 11
Col. Centro
Matamoros, Tamps. C.P. 88000
Tel. (01-88) 13 50 13
Tel. / Fax: (01-88) 13 50 13

Centro de Servicio Lugo

Rosalinada Guerrero No. 285
Col. ProL. Longoria
Reynosa, Tamps. C.P. 88699
Tel. (01-89) 24 92 43
Tel. / Fax: (01-89) 24 92 43

Esp. Electrónicas

Matamoros poniente 225
Col. Centro
Cd. Victoria, Tamps. C.P. 87000
Tel. (01-131) 299 45
Fax. (01-131) 251 93

Micronics

Calle 10 No. 607.
Col. Jardín 20 de Noviembre
Madero, Tamps. C.P. 89440
Tels. (01-12) 15 96 89
Fax: (01-12) 10 38 82

Laboratorio Electrónico

Washington 3142
Col. Juárez (Centro)
Nuevo Laredo, Tamps. C.P. 88000
Tel. (01-87) 14 95 92, 14 98 52
Fax. (01-87) 14 71 71

Electronica Emmanuel

Obregon No. 205A
Zona Centro
Cd. Mante, Tamaulipas. C.P. 89800
Tel. (01-123) 290 81
Fax. (01-123) 290 81

VERACRUZ

Grupo Digital
I. Zaragoza No. 212
Col. Centro
Coatzacoalcos, Ver. C.P. 96400
Tel. (01-921) 2 02 29
Fax. (01-921) 2 02 29

Serv Técnicos Prof.

Av. 13 No. 400 Esq. Calle 4
Col. Bella Vista
Córdoba, Ver. C.P. 94500
Tel. (01-271) 2 73 22
Fax. (01-271) 2 25 39

Electrónica Arizona

Bustamante No. 46
Col. Centro
Jalapa, Ver. C.P. 91000
Tel. (01-28) 18 78 68
Fax. (01-28) 12 25 34

Com. y Electrónica

Miguel Hidalgo No. 103
Col. Buena Vista Sur
Minatitlán, Ver. C.P. 96730
Tel. (01-922) 3 15 65
Tel. / Fax: (01-922) 3 15 65

Electrónica Digital BRR

Av. Juárez No. 516
Col. 27 de Septiembre
Poza Rica, Ver. C.P. 93320
Tel. (01-782) 3 69 49
Fax. (01-782) 3 69 49

Electrónica DICA

F. del Paso y Troncoso No. 908
Col. Centro
Veracruz, Ver. C.P. 91700
Tels. (01-29) 31 20 33; 31 22 96
Tel. / Fax: (01-29) 31 2 33

Seguridad Plus.

Oriente 4 No. 187 Esq. Sur 5
Col. Centro, C.P.
Orizaba, Ver.
Tel. (01-272) 5-0235

YUCATAN

Cinescopios
Calle 70 No. 443, oc. 7 por 49
Col. Centro
Mérida, Yuc. C.P. 97000
Tels. (01-99) 28 54 28, 28 59 05
Tel. / Fax: (01-99) 28 59 05

ZACATECAS

Electronica Mario.
Morelos Poniente No. 1214
Col. Centro
Zacatecas, Zac. C.P.
Tel. (01-492) 275 61
Fax. (01-492) 275 61

REAL

POLIZA DE GARANTIA

Comercializadora Thomson de México S.A. de C.V. garantiza este producto en todas sus partes y mano de obra, contra cualquier defecto de fabricación y funcionamiento, a partir de la fecha de entrega al cliente final. Bajo el siguiente término:

Producto	Partes	Mano de Obra
Televisores c/cinescopio de 36,6 cm. (14 pulgadas) y menores	2 años cinescopio. 1 año otras partes.	1 año
Televisores c/cinescopio de 48,3 cm (19 pulgadas) y mayores.	2 años cinescopio. 2 años otras partes.	2 años.
Televisión de Proyección	1 año	1 año
Videocaseleras	1 año	1 año
Videocámaras	1 año	1 año
Equipos de Audio	1 año	1 año
Reproductor de DVD	1 año	1 año
Accesorios	1 año	1 año

CONDICIONES

1. Para ser efectiva esta garantía se requiere presentar esta póliza y/o factura de compra, junto con el producto en cualquiera de nuestros Centros de Servicios Autorizados, (que se indican en la hoja anexa), o en el lugar donde fue adquirido.
2. Comercializadora Thomson de México se compromete a reparar y/o reponer las piezas y componentes defectuosos sin cargo al consumidor, o en caso de que a criterio de dicha empresa no sea posible la reparación, cambiar por uno nuevo, exactamente del mismo modelo o su similar. Los gastos de transportación dentro de la red de servicios, que se deriven del cumplimiento de esta póliza de garantía, serán cubiertos por Comercializadora Thomson de México S.A. de C.V.
3. Todos los productos deberán ser llevados a cualquier Centro de Servicio Autorizado, excepto los televisores con pantalla de 63,5 cm (25 pulgadas) o mas, los cuales serán reparados en el domicilio del cliente.
4. El tiempo de reparación en ningún caso será mayor a 30 días, contados a partir de la recepción del producto en el Centro de Servicio Autorizado.
5. Para la adquisición de partes y accesorios, contactar al 01-800-1117221 o acudir a Comercializadora Thomson de México.

NOTAS:

- ☒ En caso de extravío de la póliza, el consumidor debe recurrir a su distribuidor para su reposición, previa presentación de la factura o nota de compra.
- ☒ Para su comodidad, solicite informes sobre la localización del Centro de Servicio Autorizado mas cercano a su domicilio, llamando al:

01-800-1117221

Comercializadora Thomson de México, S.A. de C.V.
Miguel de Cervantes Saavedra 57 Col. Ampliación Granada
C.P. 11529 Mexico D.F.
Telefono: (65)25 81 53 20 RFC: CTM-980723-KSS

No. Póliza: _____

DATOS DEL PRODUCTO

PRODUCTO: **Receptor de audio/video Dolby Digital DVD**

MODELO: **RTD250** NO. DE SERIE: _____

DATOS DEL CLIENTE

EXPEDIDA A: _____

DIRECCION: _____

NOMBRE: _____

DIRECCION: _____

FECHA DE COMPRA: _____

SELLO Y FIRMA DEL VENDEDOR

ESTA GARANTIA NO TIENE VALIDEZ EN LOS SIGUIENTES CASOS

- Si el producto no ha sido operado de acuerdo con el instructivo de uso en español que acompaña al producto.
- Si el producto ha sido utilizado en condiciones distintas a las normales y/o se hacen caso omiso de los cuidados y advertencias que se señalan en el manual de usuario.
- Si el producto ha sido alterado, modificado o sufrido daños por causas ajenas al fabricante u ocasionadas por el consumidor.
- Si se ha tratado de reparar el aparato por personas no autorizadas por Comercializadora Thomson de Mexico



IMPORTADOR

Comercializadora Thomson de Mexico, S.A. de C.V.
Miguel de Cervantes Saavedra 57
Col. Ampliacion Granada
C.P. 11529 Mexico D.F.
Telefono: (55)25 81 53 20
R.F.C.: CTM-980723-KS5

0151

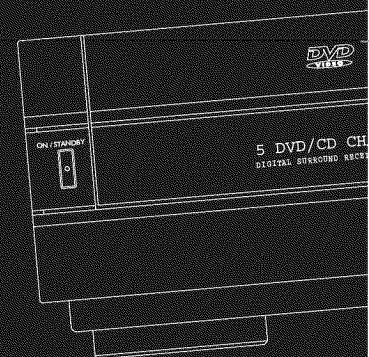

EXPORTER

Thomson Inc.
P.O. Box 1976
Indianapolis, IN 46206 - 1976
© 2003 Thomson Inc.
Trademark(s) ® Registered
Marca(s) Registrada(s)
Marque(s) Déposée
5563908A (EN/F/E)
www.rca.com
www.rca.com/LatinAmerica
Printed in China / Impreso en China