

Sears

*owners
manual*

**MODEL NO.
113.23112**

Serial
Number

Model and serial
number may be found
at the rear left-hand side
of the base.

You should record both
model and serial number
in a safe place for
future use.

CAUTION:

**Read GENERAL
and ADDITIONAL
SAFETY
INSTRUCTIONS
carefully**

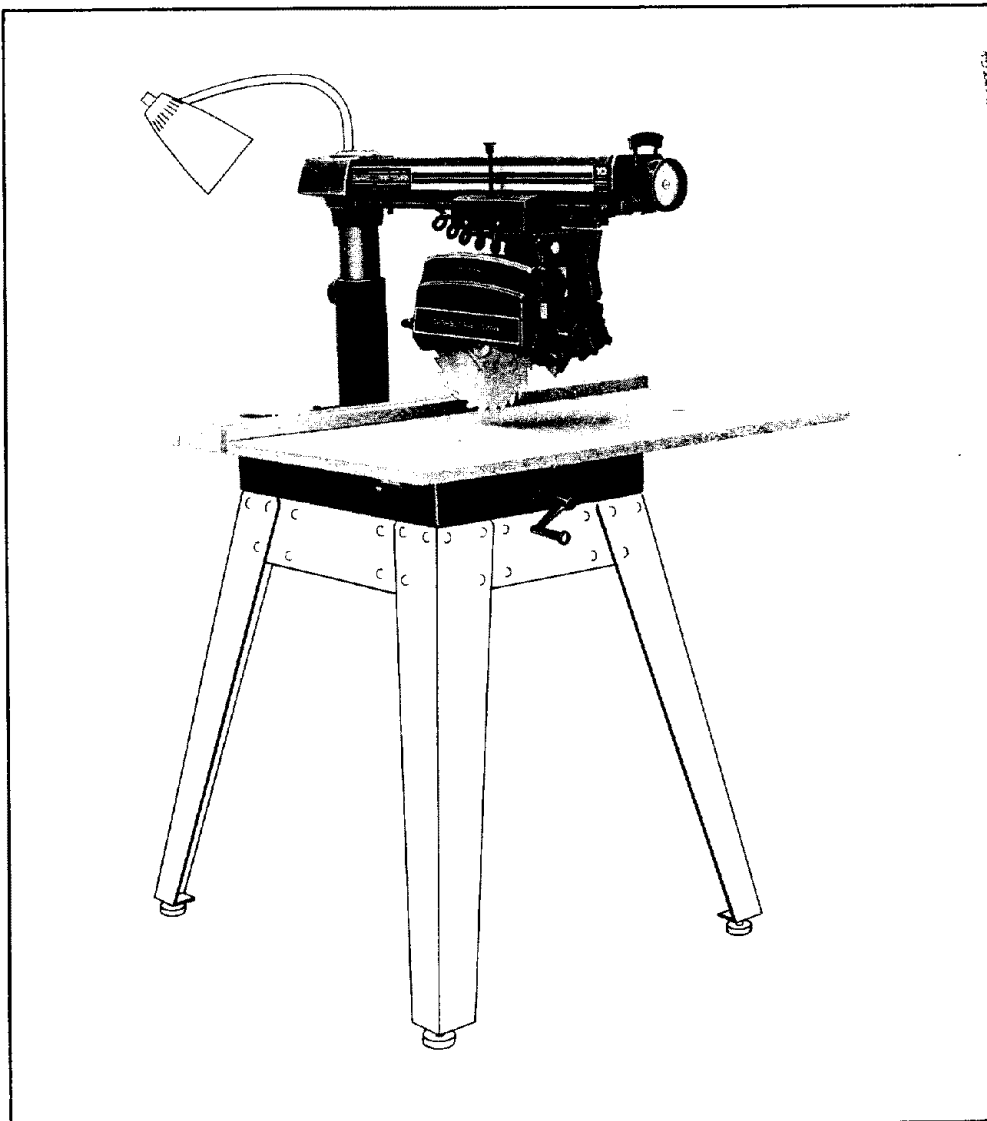

Sears

CRAFTSMAN.

**10-INCH
RADIAL SAW**

- *assembly*
- *operating*
- *repair parts*

Sold by SEARS, ROEBUCK AND CO., Chicago, IL. 60684 U.S.A.

FULL ONE YEAR WARRANTY ON CRAFTSMAN RADIAL SAWS

If within one year from the date of purchase, this Craftsman Radial Saw fails due to a defect in material or workmanship, Sears will repair it, free of charge.

Warranty service is available by simply contacting the nearest Sears store or Service Center throughout the United States.

This warranty gives you specific legal rights, and you may also have other rights which vary from state to state.

SEARS, ROEBUCK AND CO.
BSC 41-3
SEARS TOWER
CHICAGO, IL 60684

general safety instructions for power tools

1. KNOW YOUR POWER TOOL

Read the owner's manual carefully. Learn its application and limitations as well as the specific potential hazards peculiar to this tool.

2. GROUND ALL TOOLS

This tool is equipped with an approved 3-conductor cord and a 3-prong grounding type plug to fit the proper grounding type receptacle. The green conductor in the cord is the grounding wire. Never connect the green wire to a live terminal.

3. KEEP GUARDS IN PLACE

in working order, and in proper adjustment and alignment.

4. REMOVE ADJUSTING KEYS AND WRENCHES

Form habit of checking to see that keys and adjusting wrenches are removed from tool before turning it on.

5. KEEP WORK AREA CLEAN

Cluttered areas and benches invite accidents. Floor must not be slippery due to wax or sawdust.

6. AVOID DANGEROUS ENVIRONMENT

Don't use power tools in damp or wet locations or expose them to rain. Keep work area well lighted. Provide adequate surrounding work space.

7. KEEP CHILDREN AWAY

All visitors should be kept a safe distance from work area.

8. MAKE WORKSHOP KID-PROOF

- with padlocks, master switches, or by removing starter keys.

9. DON'T FORCE TOOL

It will do the job better and safer at the rate for which it was designed.

10. USE RIGHT TOOL

Don't force tool or attachment to do a job it was not designed for.

11. WEAR PROPER APPAREL

Do not wear loose clothing, gloves, neckties or jewelry (rings, wrist watches) to get caught in moving parts. Non-slip footwear is recommended. Wear protective hair covering to contain long hair. Roll long sleeves above the elbow.

12. USE SAFETY GOGGLES (Head Protection)

Wear Safety goggles (must comply with ANS Z87.1) at all times. Also, use face or dust mask if cutting operation is dusty, and ear protectors (plugs or muffs) during extended periods of operation.

13. SECURE WORK

Use clamps or a vise to hold work when practical. It's safer than using your hand, frees both hands to operate tool.

14. DON'T OVERREACH

Keep proper footing and balance at all times.

15. MAINTAIN TOOLS WITH CARE

Keep tools sharp and clean for best and safest performance. Follow instructions for lubricating and changing accessories.

16. DISCONNECT TOOLS

before servicing; when changing accessories such as blades, bits, cutters, etc.

17. AVOID ACCIDENTAL STARTING

Make sure switch is in "OFF" position before plugging in.

18. USE RECOMMENDED ACCESSORIES

Consult the owner's manual for recommended accessories. Follow the instructions that accompany the accessories. The use of improper accessories may cause hazards.

19. NEVER STAND ON TOOL

Serious injury could occur if the tool is tipped or if the cutting tool is accidentally contacted.

Do not store materials above or near the tool such that it is necessary to stand on the tool to reach them.

20. CHECK DAMAGED PARTS

Before further use of the tool, a guard or other part that is damaged should be carefully checked to ensure that it will operate properly and perform its intended function. Check for alignment of moving parts, binding of moving parts, breakage of parts, mounting, and any other conditions that may affect its operation. A guard or other part that is damaged should be properly repaired or replaced.

21. DIRECTION OF FEED

Feed work into a blade or cutter against the direction of rotation of the blade or cutter only.

22. NEVER LEAVE TOOL RUNNING UNATTENDED

Turn power off. Don't leave tool until it comes to a complete stop.

additional safety instructions for radial saws

CAUTION: Always disconnect the power cord before removing the guard, changing the cutting tool, changing the set-up or making adjustments. Shut off motor before performing layout work on the saw table.

WARNING: DO NOT CONNECT POWER CORD UNTIL THE FOLLOWING STEPS HAVE BEEN SATISFACTORILY COMPLETED:

- I. Assembly and alignment.
- II. Examination and operating familiarity with ON-OFF switch, elevation control, yoke index and lock, bevel index and lock, carriage lock, guard clamp screw, spreader and anti-kickback device, and miter index and lock.
- III. Review and understanding of all Safety Instructions and Operating Procedures thru-out manual.

INSTALLATION

1. Set carriage lock before moving the saw.
2. Bolt the saw to the floor if it tends to slip, walk, or slide during normal operation.
3. Mount the saw so the table
 - is approximately 39" above the floor;
 - slopes slightly downward to the rear so the carriage will not roll forward due to gravity.

MINIMIZE ACCIDENT POTENTIAL

Most accidents are caused by FAILURE TO FOLLOW setup and operating instructions:

(A) GENERAL

- Avoid awkward hand positions, where a sudden slip could cause a hand to move into a sawblade or other cutting tool. Never reach in back of or around the cutting tool with either hand to hold down the workpiece, or for any other reason; DO NOT place fingers or hands in the path of the sawblade.
- Never saw, dado, mold, or rabbet unless the proper guard is installed and set up as instructed.
- NOTE THE FOLLOWING DANGER LABELS WHICH APPEAR ON THE FRONT OF THE YOKE AND GUARD:

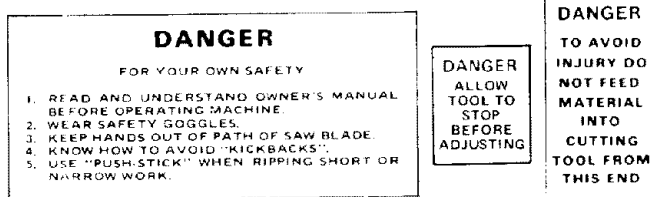

- Always maintain control of the workpiece -- DO NOT "let go" the workpiece until the cutting tool has come to a stop.
- If any part of this radial saw is missing or should break, bend or fail in any way, or any electrical component fail to perform properly, shut off power switch, remove cord from power supply and replace damaged, missing and/or failed parts before resuming operation.
- IF YOUR SAW MAKES AN UNFAMILIAR NOISE OR IF IT VIBRATES EXCESSIVELY CEASE OPERATING IMMEDIATELY UNTIL THE SOURCE HAS BEEN LOCATED AND THE PROBLEM CORRECTED.
- **WARNING: DO NOT ALLOW FAMILIARITY (GAINED FROM FREQUENT USE OF YOUR**

SAW) TO BECOME COMMONPLACE. ALWAYS REMEMBER THAT A CARELESS FRACTION OF A SECOND IS SUFFICIENT TO INFLICT SEVERE INJURY.

- Before starting work, verify that no play exists between the column & column support, or in the carriage, and that arm, yoke, and bevel locks/clamps are tight.
- A large proportion of saw accidents is caused by use of the wrong type blade, dull, badly set, improperly sharpened cutting tools, by gum or resin adhering to cutting tools, and by sawblade misalignment with the fence. Such conditions can cause the material to stick, jam (stall the saw) or "KICKBACK". A "KICKBACK" occurs when a part or all of the workpiece is thrown back violently toward the operator. NEVER ATTEMPT TO FREE A STALLED SAW BLADE WITHOUT FIRST TURNING THE SAW "OFF". If the sawblade is stalled or jammed, shut saw "OFF", remove workpiece, and check sawblade squareness to table surface and to the fence, and check for heel. Adjust as indicated.
- **CAUTION: DO NOT cycle the motor switch "ON" and "OFF" rapidly, as this might cause the sawblade to loosen. In the event this should ever occur, allow the saw blade to come to a complete stop and re-tighten the arbor nut normally, not excessively.**
- Do not leave a long board (or other workpiece) unsupported so the spring of the board causes it to shift on the table. Provide proper support for the workpiece, based on its size and the type of operation to be performed. Hold the work firmly against the fence and down against the table surface.
- Never use a length stop on the free end of the workpiece when crosscutting. Never hang onto or touch the free end of workpiece when crosscutting, or a free piece that is cut off when ripping while power is "ON" and/or the saw blade is rotating. In short, the cut-off piece in any "thru-sawing" (cutting completely thru the workpiece) operation must never be confined -- it must be allowed to move laterally.
- Make sure your fingers do not contact the terminals when installing or removing the plug to or from a live power source.
- Never climb on the saw, or climb near the saw when power is "ON". Never leave the saw with power "ON", or before the cutting tool has come to a complete stop. Lock the motor switch and put away the key when leaving the saw.
- Do not use any blade or other cutting tool marked for an operating speed lower than 3450 RPM. Never use a cutting tool larger in diameter than the diameter for which the saw was designed. For greatest safety and efficiency when ripping, use the maximum diameter blade for which the saw is designed, since under these conditions the spreader is nearest the blade.
- Never turn your saw "ON" before clearing the table or work surface of all objects (tools, scraps of wood, etc.) except the workpiece and related feed or support devices for the operation planned.
- DO NOT perform layout, assembly, or setup work on the table while the cutting tool is rotating.
- Never perform any operation "FREE HAND". This term means feeding the sawblade into the workpiece (crosscutting) or feeding the sawblade or other cutting tool (ripping) without using the fence to

additional safety instructions for radial saws

support or guide the workpiece, to prevent rotating or twisting of the workpiece during the operation. Never "RIP" in the crosscut position. Never make a miter cut with the arm in the 90° crosscut position.

- Never lower a revolving cutting tool into the table or a workpiece without first locking the Carriage Lock Knob. Release the knob only after grasping the Yoke Handle. Otherwise the cutting tool may grab the workpiece and be propelled toward you.
- The sawblade, dado, or other cutting tool must be removed from the saw arbor before using the accessory shaft (rear end of the saw motor). NEVER operate the saw with cutting tools (including sanding accessories) installed on both ends of the saw arbor.

(B) RIPPING

1. Feed force when ripping must always be applied **BETWEEN THE SAW BLADE AND THE FENCE**. . . use a "PUSH STICK" for narrow or short work.
2. Whenever possible, use the in-rip position — this provides minimum obstruction for feeding by hand or push stick as appropriate.
3. Do not release the workpiece before operation is complete — push the workpiece all the way past the rear (outfeed or exit) of the sawblade.
4. Make sure by trial before starting the cut that the anti-kickback pawls will stop a kickback once it has started. Points of pawls must be SHARP. Replace when points are dull or rounded.
5. Use a push stick when ripping short (under 12 inches) or narrow (under 6 inches wide) workpieces.
6. **CAUTION: Never reposition the Guard or anti-kickback with power "ON".**
7. A "KICKBACK" occurs during a rip-type operation. It can occur when the workpiece closes in on the rear (outfeed side) of the sawblade (pinching), binds between the fence and the sawblade (heel), or is grabbed by the sawblade teeth (wrong-way feed) at the outfeed side. "PINCHING" is generally avoided by utilization of the spreader, and a sharp sawblade of the corrective type for the workpiece being cut. "HEEL" can be avoided by maintaining the sawblade exactly parallel to the fence. (see "DANGER" warning on guard) — it can be avoided by maintaining parallelism of sawblade to fence, feeding into the sawblade from the nose of the guard only, and by utilizing the spreader.
8. Position the nose of the guard to just clear the workpiece, and position/adjust the anti-kickback and spreader devices as instructed.
9. NEVER cut more than one piece at a time by stacking workpieces vertically.
10. NEVER feed a workpiece thru the saw with another piece (butting second piece against trailing edge of piece being cut), even if of the same thickness. Feed each workpiece individually thru the sawblade, and completely beyond the sawblade, before ripping the next workpiece. Use push stick if the rip cut is less than 6" wide.
11. DO NOT pull the workpiece thru the sawblade
 - position your body at the nose (in-feed) side of the guard: start and complete the cut from that same side. This will require added table support for long pieces.
12. Plastic and composition (like styrene and hardboard) materials may be cut on your saw. However, since these are usually quite hard and

slippery, the anti-kickback pawls may not stop a kickback.

Therefore, rip with the finished side down (next to the table) and be especially attentive to following proper set-up and cutting procedures. Do not stand, or permit anyone else to stand, in line with a potential kickback.

13. When sawing 1/4" or thinner materials, follow all normal ripping procedures except set sawblade into table top at least 1/8". This will minimize the tendency for the sawblade to climb upon top of the workpiece, and possibly cause an accident. DO NOT let go of or stop feeding the workpiece between the blade and fence until you have pushed it completely past the anti-kickback pawls. Otherwise the workpiece could get into the back of the sawblade and be thrown violently from the saw in the direction opposite to the feed direction. This is the same action that would occur if the instructions of the DANGER warning on the guard is aborted. Do not stand, or permit anyone else to stand, in line with the path of a workpiece that may be thrown from the saw in this manner.
14. Position the saw so neither you, a helper, or a casual observer is forced to stand in line with the sawblade.
15. Use extra care when ripping wood that has a twisted grain or is twisted or bowed — it may rock on the table and/or pinch the sawblade. If bowed across the width, place concave side down against the table.

(C) CROSSCUTTING

1. ALWAYS RETURN THE CARRIAGE TO THE FULL REARWARD POSITION AT CONCLUSION OF EACH CROSSCUT TYPE OPERATION. Never remove your hand from the Yoke Handle unless the carriage is in this position. Otherwise the cutting tool may climb up on the workpiece and be propelled toward you.
2. Place guard in horizontal position and adjust anti-kickback pawls to just clear the top of the fence or workpiece, whichever is higher.
3. NEVER gang crosscut — lining up more than one workpiece in front of the fence — stacked vertically, or horizontally outward on the table — and then pulling saw thru: the blade could pick up one or more pieces and cause a binding or loss of control and possible injury.
4. Do not position the Arm so the operation you are performing permits the cutting tool to extend beyond the edges of the Table.

(D) ACCESSORIES

1. Use only recommended accessories as listed on page 33.
2. Never operate this saw when equipped with a dado head or molding head unless the molding head guard is installed — see listing of recommended accessories. The only exception is when "top-side" dadoing or molding, when the sawblade guard must be used. See detailed instructions that accompany the dado head, molding head, and molding head guard.
3. The use of abrasive or cut-off wheels, or wire wheels, can be dangerous and is not recommended. (Abrasive or cut-off wheels are used to saw many different materials including metals, stone, and glass.)

additional safety instructions for radial saws



The operation of any power tool can result in foreign objects being thrown into the eyes, which can result in severe eye damage. Always wear safety goggles complying with ANSI Z87.1 (shown on Package) before commencing power tool operation. Safety Goggles are available at Sears retail or catalog stores.

unpacking and assembly

CONTENTS

General Safety Instructions for Power Tools	2	Electrical Connections	21
Additional Safety Instructions for Radial Saws	3	Trouble-Shooting	22
Unpacking and Assembly	5	Maintenance and Lubrication	26
Alignment Procedure	8	Recommended Accessories	27
Operating Controls	14	Repair Parts	28
Basic Saw Operations	17		

TOOLS NEEDED

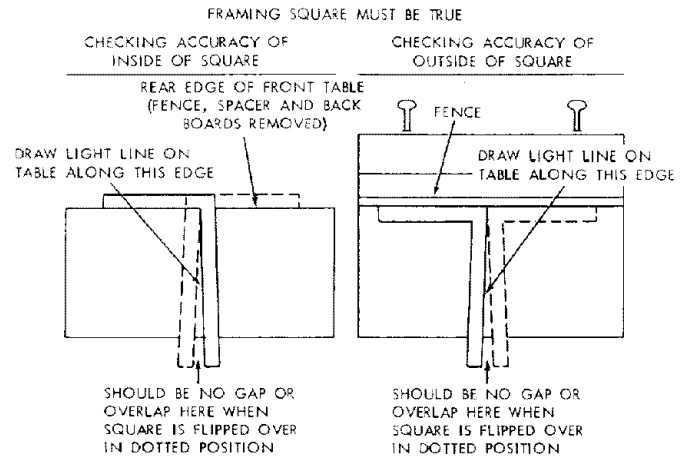
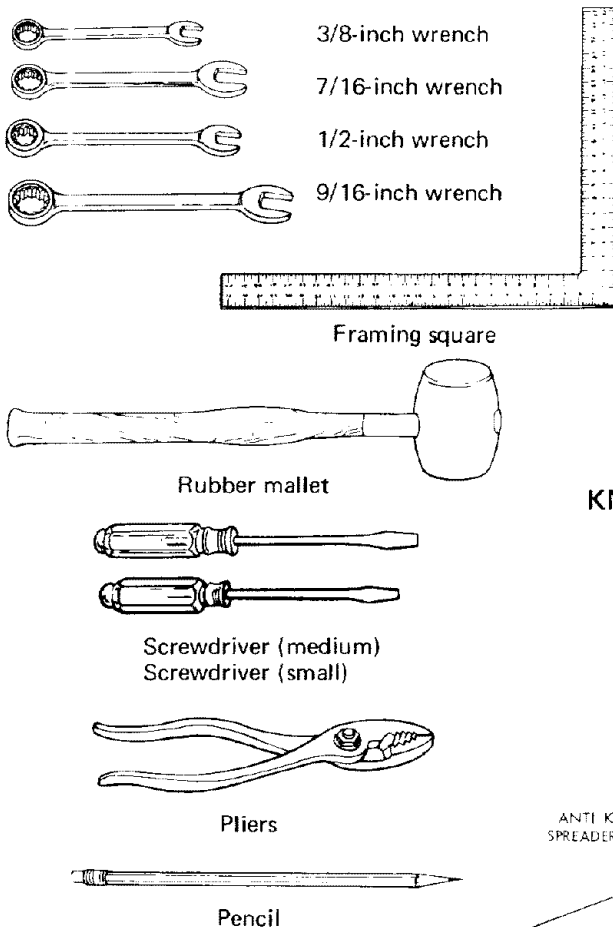

KNOW LOCATIONS AND FUNCTIONS OF CONTROLS

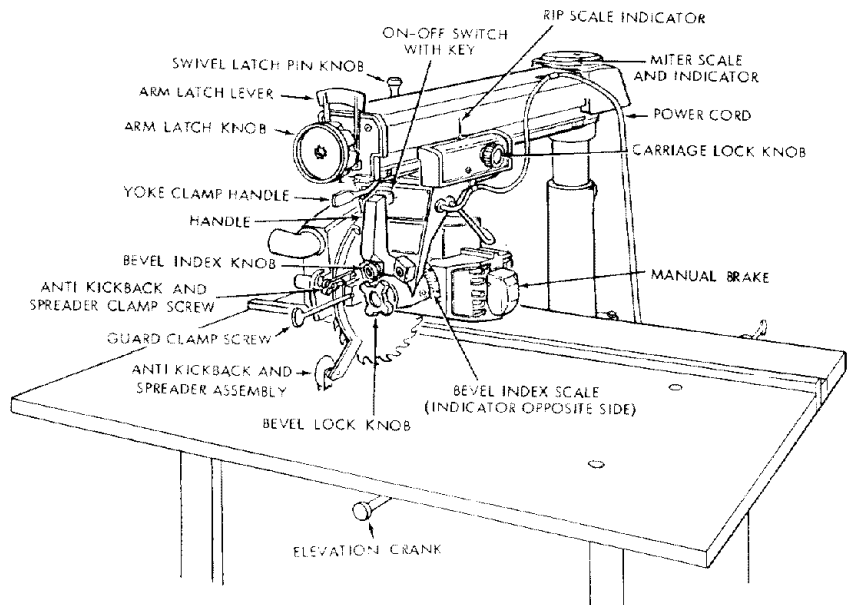

unpacking and assembly

UNPACKING AND PREASSEMBLY

WARNING: DO NOT CONNECT THE POWER CORD TO A SOURCE OF POWER. THIS CORD MUST REMAIN UNPLUGGED WHENEVER YOU ARE WORKING ON THE SAW.

1. Unpacking and Checking Contents

Separate all "loose" parts from packaging materials and check each item with "Table of Loose Parts" to make sure all items are accounted for, before discarding any packing material.

If any parts are missing, do not attempt to assemble the radial saw, plug in the power cord or turn the switch on until the missing parts are obtained and installed correctly.

Key No. (Fig. 1)	Table of Loose Parts	Qty.
1	Basic Saw assembly	1
2	Rear table	1
3	Table spacer	1
4	Rip fence	1
5	Front table	1
6	"Owner's Manual"	1
7	Channel, Table Mtg.	2
8	Loose Parts Bag Part No. 63510 (containing the following items):	
	Hex-"L" Wrench, 1/8"	1
	Hex-"L" Wrench, 3/16"	1
	Elevation crank assembly	1
	Switch key	2
	Arbor Wrench	1
	Table clamp	2
	Rip-scale indicator	1
	Twin nut (for attaching rip-scale indicator)	1

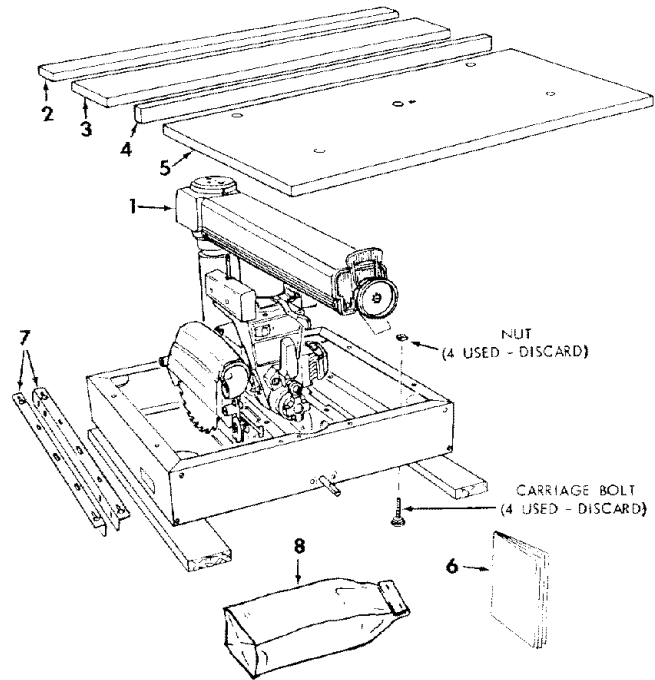

Machine screw, pan-hd., 1/4-20 x 1"	4
Washer, steel (flat), 17/64 x 5/8 x 1/32"	5
Machine Screw, pan-hd., 1/4-20 x 1-1/4"	1
Screw Slotted set 1/4-20 x 1/2"	1
Nut Tee	1
Machine screw, pan-hd., 6-32 x 7/16"	2
Shaft wrench	1
Screw, Hex hd., 5/16-18 x 1/2	4
Lockwasher, 5/16	4
Washer, Flat, 11/32 x 7/8 x 1/16	4
Washer, Flat, 5/16 x 9/16 x 1/16	2
Nut, Lock, 5/16-18	2
Nut, Speed	4

REMOVE SKIDS FROM BASE

MOUNT SAW TO CRAFTSMAN BASE OR LEG SET, OR FLAT BENCH

(NOT SUPPLIED IN CANADA)

Make sure elevation crank is free to rotate. The saw must be bolted down. Position your entire saw (or saw bench) to slope slightly rearward, so the carriage will not roll forward due to gravity.

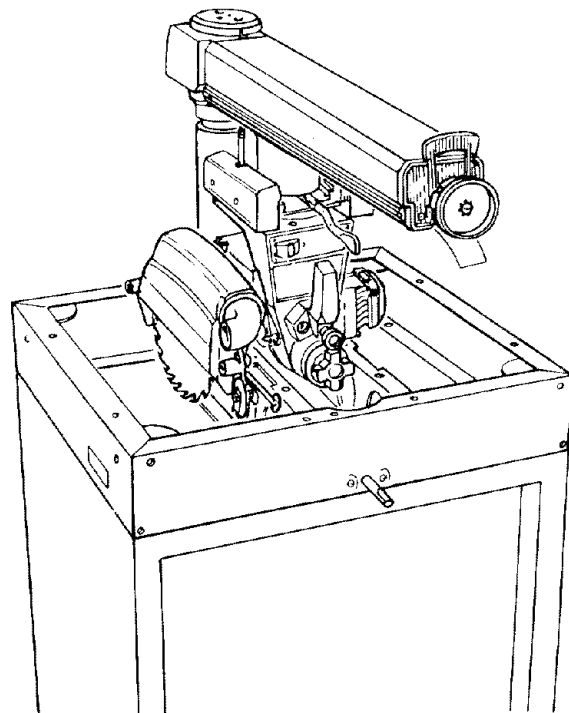

ATTACH ELEVATION CRANK.
Be sure setscrew is tightened on flat of shaft.

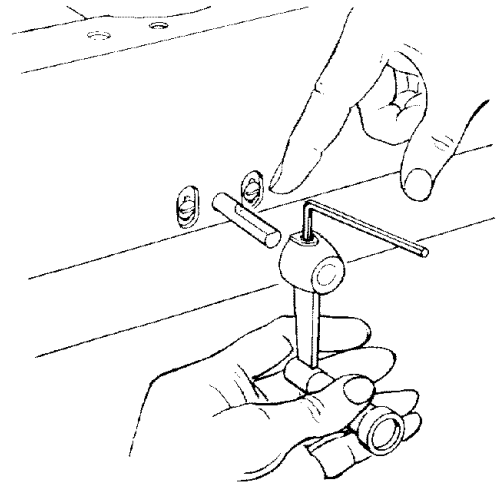

ELEVATE ARM TO ITS MAX. HEIGHT.
Remove shipping block.

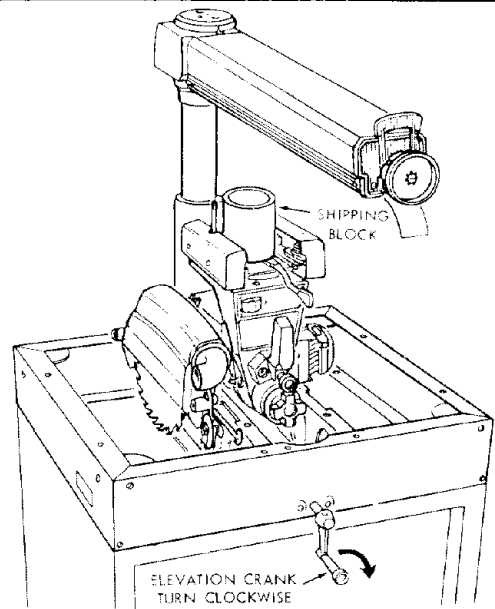

REMOVE CARRIAGE STOP SCREW, LOCKWASHER AND TAG. Read warning tag before discarding.

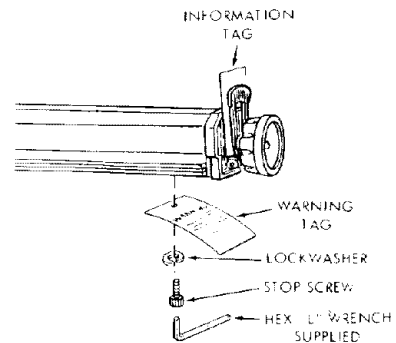

TIGHTEN ARM LOCK KNOB BEFORE PROCEEDING.

HOLDING CARRIAGE ASSEMBLY WITH BOTH HANDS, CAREFULLY START AND SLIDE THE CARRIAGE ONTO THE TRACKS. The assembly must be held parallel with the arm so that all four bearings slide smoothly onto the arm, preventing any excessive strain on bearings and track.

WARNING: REINSTALL CARRIAGE STOP SCREW TO PREVENT CARRIAGE FROM ROLLING OFF ARM.

Check for looseness of carriage bearings. Refer to Paragraph 8, Trouble Shooting Section.

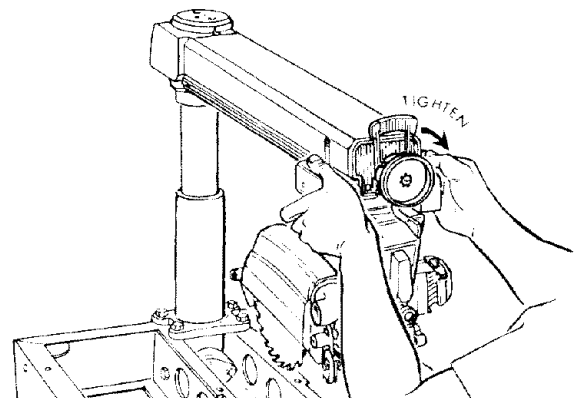

unpacking and assembly

REMOVE SHIPPING SCREWS AND DISCARD.

Use of pliers may be necessary.

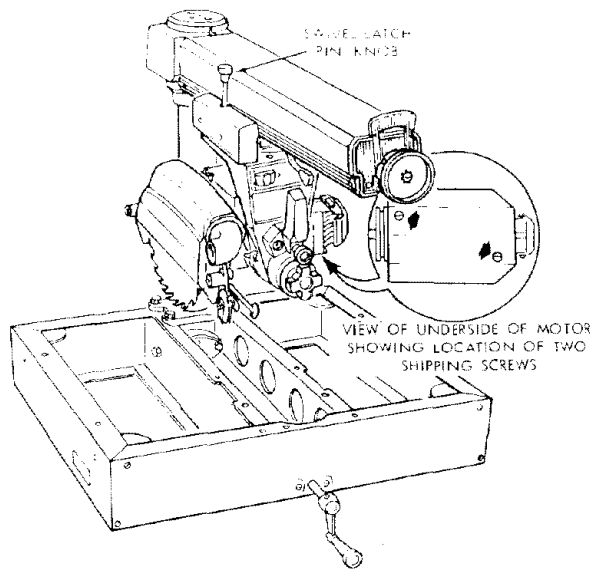

REMOVE SAW BLADE.

1. Tighten carriage lock knob.
2. Loosen guard clamp screw, remove guard.
3. Motor shaft has left hand threads. Hold shaft wrench and rotate arbor wrench down (clockwise).
4. Remove shaft nut, outer collar, saw blade, and inner collar. Set aside and out of the way.

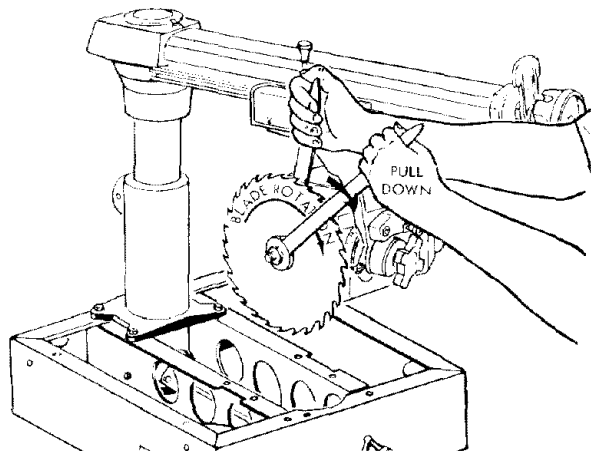

ALIGNMENT PROCEDURE

The following SIX STEP alignment procedure will bring out the accuracy which is built in every CRAFTSMAN tool. The secret for best results is in knowing how to set up the tool and keep it in good alignment. BE SURE TO CHECK AND ALIGN THE SAW IN THE ORDER GIVEN, STEP-BY-STEP. THE ACCURACY OF EACH ADJUSTMENT IS ALWAYS DEPENDENT UPON THE ACCURACY OF THE PRECEDING ADJUSTMENT.

After following the 6 step assembly and alignment procedure and the Basic Saw operation section refer to Trouble Shooting section if any difficulty is experienced when performing any sawing operation.

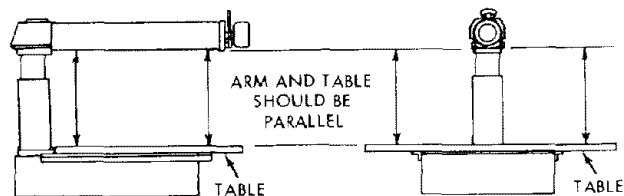

STEP ONE

ATTACHING AND LEVELING TABLE MOUNTING SUPPORT CHANNELS.

1. Attach table mounting support channels with four 5/16-18 x 1/2 screws, lockwashers and flat washers. Position screws in center of channel slots, finger tight to permit channels to "slip" against the base when leveling.
2. Loosen bevel lock knob, lift up on latch pin handle and rotate the motor to position saw blade, end of shaft down.

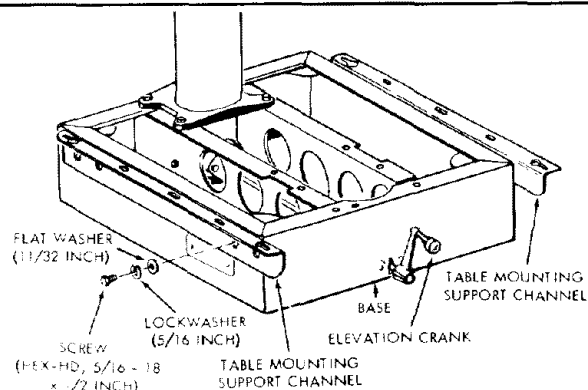

- Loosen arm lock knob until arm is free to move.

Note: In accordance with the UL standard, stops have been provided to prevent 360° rotation of the radial arm.

Loosen carriage lock knob and position arm against stop (approximately 50° Miter) and carriage directly over the center of left hand channel.

- Slide the arbor wrench handle between end of motor shaft and mounting channel to achieve an accurate measurement. Carefully lower the motor with elevation crank until the end of shaft is just touching the arbor wrench. The wrench should slide back and forth with only slight resistance. Tighten screw "A".

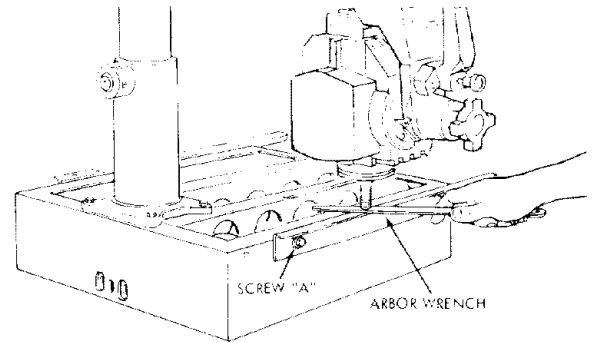

NOTE: Do not change this elevation setting until both left and right hand table support channels have been adjusted.

- Move arm and carriage to screw "B" and tighten support in the same manner.
- Move arm and carriage to right hand support channel and level in the same manner you adjusted the left hand support channel.
- Recheck both support channels to make sure that tightening screws did not affect the accuracy of the adjustment.
- Elevate saw and place motor in vertical position to provide clearance for installation of front (work) table.

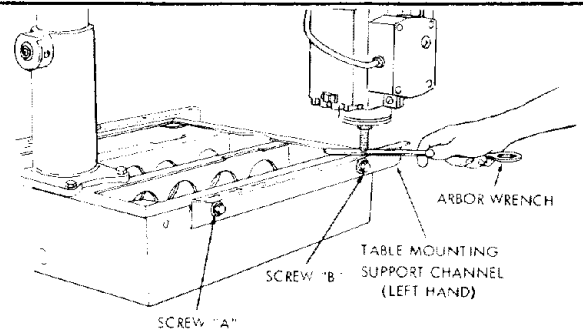

NOTE: The following adjustment, performed properly, will result in the work table being parallel to the arm.

INSTALLATION OF FRONT (WORK) TABLE.

- Place front table board on a workbench or the floor. Drive T-nut into the smaller diameter hole.
- Align the counterbore holes with matching holes in support channels. Install the five (5) 17/64 inch flat washers, and 1/4 - 20 x 1 inch pan-head machine screws. Just barely start the cup point set screw and the one (1) 1/4 - 20 x 1-1/4 inch pan-head machine screw in table center hole.
- Install one speed nut on each of the four screws in the support channels loosely.

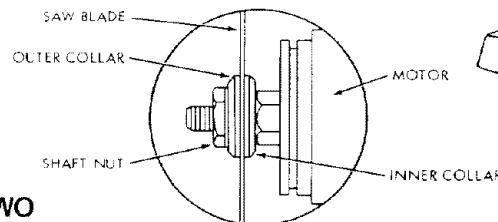
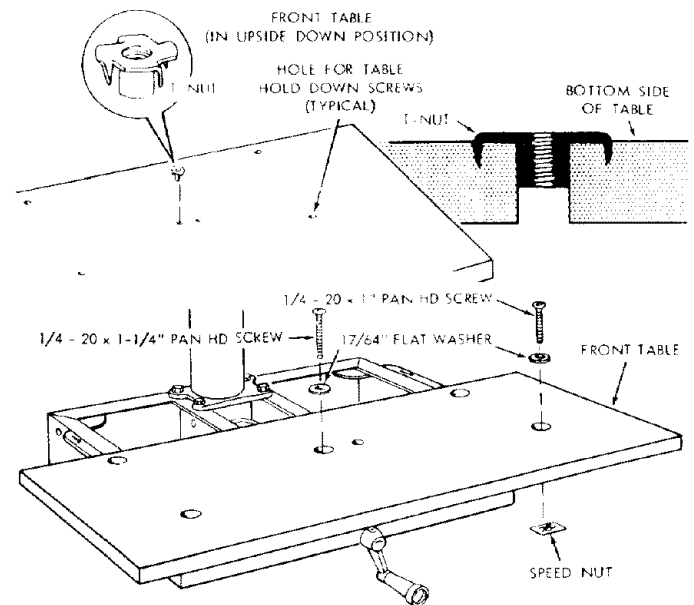

CHECK FOR LOOSENESS (MOVEMENT) OF COLUMN TUBE IN COLUMN SUPPORT. (ARM END PLAY)

NOTE: The following adjustment is very CRITICAL. All future alignment procedures rely on this adjustment being performed correctly. ALL LOOSENESS MUST BE REMOVED.

- Install saw blade as shown. Motor shaft has left hand threads.

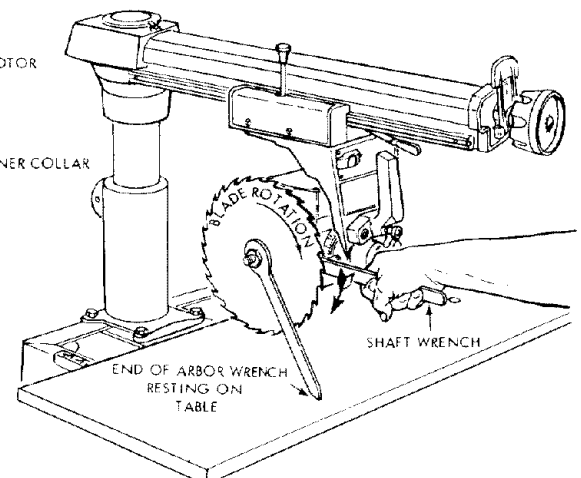

unpacking and assembly

- Position arm at approximately 30° miter setting and lock arm lock knob. Loosen arm lock knob 1/4 turn and index arm at 0° miter setting. Push the arm latch solidly with palm of hand . . . this will seat the arm index pin properly.

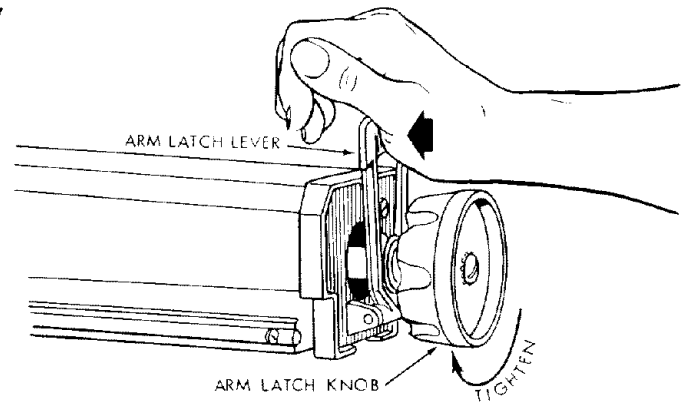

- While holding the arm latch knob with one hand, hold fingers of other hand as shown, between column tube and column support. Apply gentle side force to the radial arm in opposing directions. Any looseness between column and column support, (indicated by arrow) can be felt with fingers.

Right and left positions are given with operator facing the saw – standing in front of the saw table.

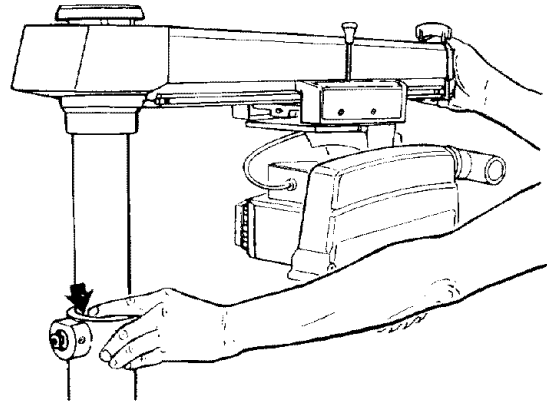

- If looseness can be felt, perform operations as follows:
 - Loosen set screw in center of column tube key.
 - Loosen left hand set screw 1/4 turn.
 - Tighten right hand set screw until looseness between column and column support is eliminated. Turn elevation crank to raise radial arm, if saw elevates too hard, loosen right hand set screw slightly and again check elevation and column tube for looseness. When correct, tighten left hand set screw.
 - Tighten set screw in center of column tube key. Elevate and lower arm if chatter or rough elevation exists, tighten set screw until smoothest operation is obtained.
 - Turn elevation crank to raise and lower radial arm. If too tight, loosen right hand set screw slightly and

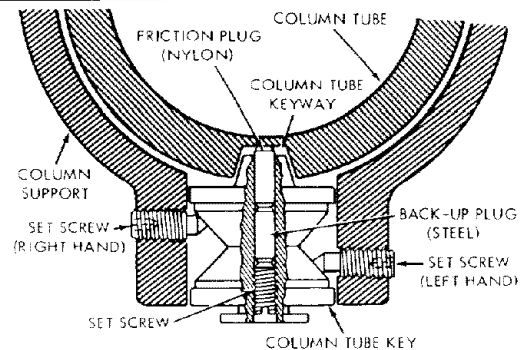

SECTIONAL VIEW LOOKING DOWN

check again for smooth operation. When correct, tighten left hand set screw.

- Tighten set screw in center of column tube key until smoothest operation is obtained.

STEP THREE

SQUARING CROSS CUT TRAVEL (CARRIAGE TRAVELS IN A STRAIGHT LINE).

- Lower arm until saw blade just clears the front table. Lock the yoke clamp handle and bevel lock knob.
- Place a framing square on the table as shown and position the blade and square until the leg of the square just contacts a tooth of the blade. Mark this tooth.

NOTE: The framing square must be "true" – see start of "Unpacking and Assembly" section on page 5 for checking method.

- When the carriage is moved back and forth on the radial arm, the marked tooth should just touch the square at all points. If marked tooth does not touch the square at all points, make the following adjustments:

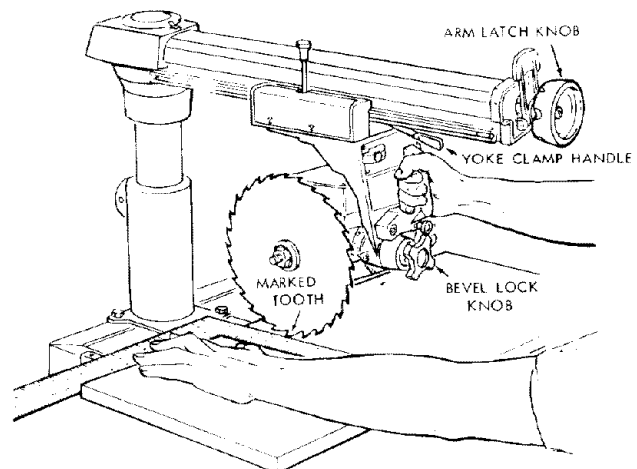

If marked tooth moves into the square when moving the blade from the rear toward the front of the table, tap the left hand front edge of the table with a mallet as shown (Loosen table attaching screws slightly if necessary).

If the marked tooth moves away from the square when moving saw from the rear to the front of saw table, tap the right hand front edge of the table.

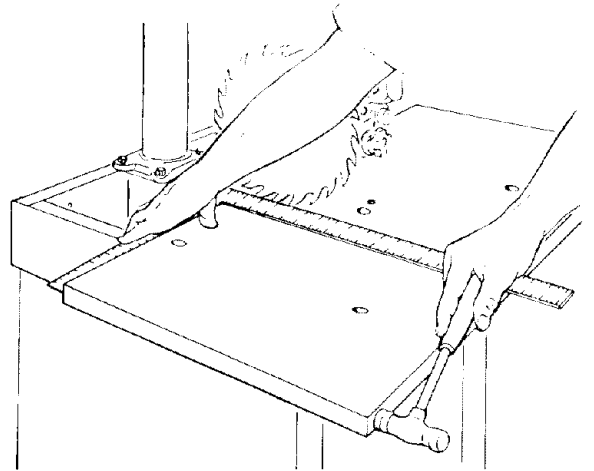

Recheck and, if correct, tighten all table hold-down screws securely. Set indicator at 0° position.

NOTE: This squaring of the cross cut travel will simultaneously set BOTH of the 45° miter index positions.

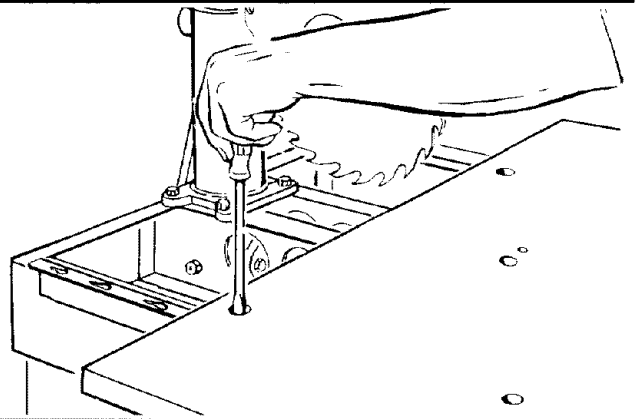

4. In extreme cases, the above adjustment procedure may not be sufficient due to rough handling during shipment. Make the following adjustment only after tightening the table hold-down screws and the cross cut cannot be squared according to the preceding adjustment routine.

- a. Remove radial arm cap and miter-scale indicator.
- b. Turn the arm latch knob one-quarter turn counterclockwise.
- c. Loosen (do not remove) two hex-head screws located inside the column tube.
- d. Move the radial arm slightly in proper direction to make marked tooth follow edge of square when the saw blade is moved along arm in a "cross cut" manner.
- e. Retighten the hex head screws in column tube, retighten arm latch knob.

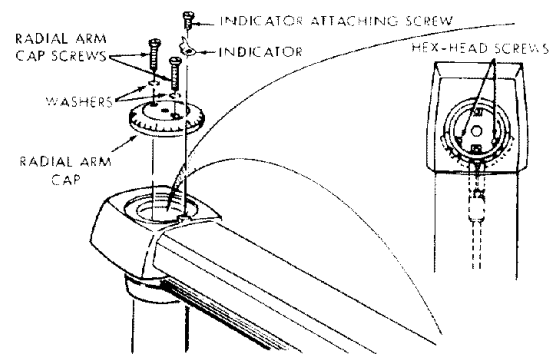

- f. Recheck travel of blade.
- g. After the cross cut has been accurately squared, install the radial arm cap and miter-scale indicator. Set the indicator at the 0° position.

LEVELING FRONT TABLE

1. Lay the rear table board on edge across the front table to serve as a straightedge. Sight under this straightedge to determine whether the front table board is high or low at its center.
2. If the front table is high at center, first tighten the center (1/4" - 20 x 1-1/4 inch) hold down screw until the table is level - then tighten the leveling screw until this screw is snug.
If table is low at center, first tighten the leveling screw until the table is level - then tighten the hold down screw.

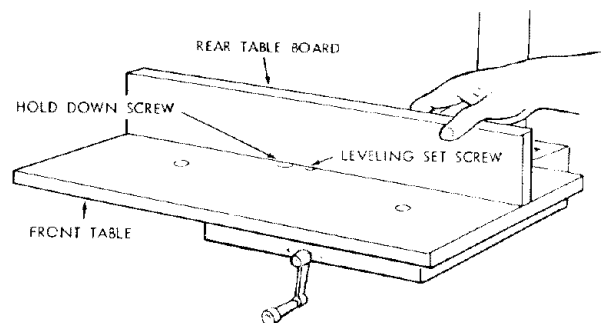

unpacking and assembly

INSTALLING REMAINING REAR TABLE BOARDS.

1. Position the rip (guide) fence, spacer board and rear table board behind the front table board, as shown.
2. Install the two table clamps in the slots provided for them at the rear of the saw base, and tighten them securely.

NOTE: The life of your saw table will be lengthened considerably if you will cover the front table with a fitted piece of 1/4 inch plywood. This should be tacked in place for easy replacement. Use of such a cover will allow you to do all cutting into the cover, rather than your table top.

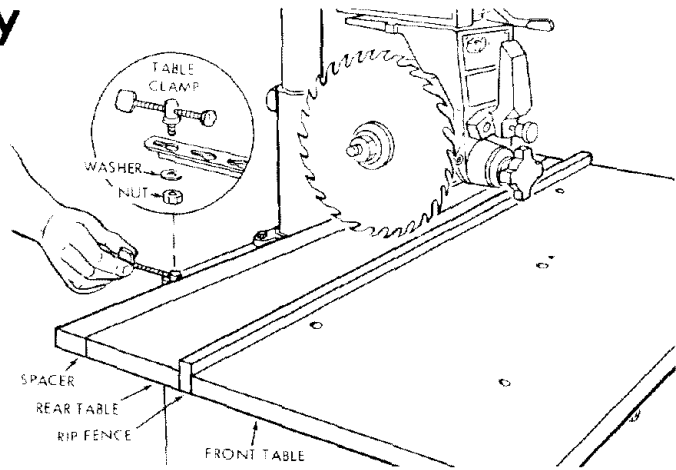

STEP 4

SQUARING SAW BLADE TO (WORK) TABLE

NOTE: If alignment procedure step one was not performed, this adjustment can not be accomplished.

1. Place a framing square on the table with the short leg against the saw blade. Do not allow the square to rest against a "set-out" tooth; it must rest flat against the blade side.
2. If the saw blade is square with the table top (no visible gap appears between the saw blade and square) and no adjustment is required. Set bevel indicator to 0° reading. If the square does not touch the saw blade as shown (with square leg held firm against the table top), perform the following adjustments:
 - a. Loosen bevel lock knob 1/4 turn only, then loosen the two Hex-head screws, one on each side of handle. Rotate motor while holding square firmly against saw blade and table top.
 - b. Slightly tighten each of the two screws and recheck . . . Now tighten each screw firmly. Retighten bevel lock knob.
 - c. Adjust indicator to 0° reading.

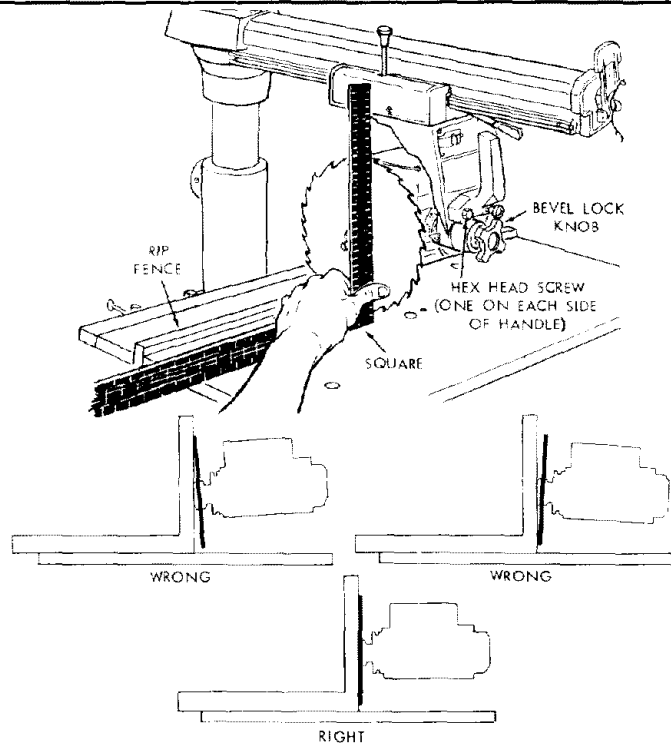

STEP 5

SQUARING BLADE TO RIP (GUIDE) FENCE – BLADE HEEL ADJUSTMENT.

NOTE: If alignment procedure steps two and four were not performed, this alignment step cannot be accomplished.

1. Place a framing square against the rip fence and the saw blade, as shown. The long leg of the square must be held firmly against both the fence and the table top, and the short leg must not touch any of the teeth on the saw blade.
2. If the square does not touch the blade at both of the two points as shown, a heel condition exists (either to the left or right) or sometimes called heel or toe.

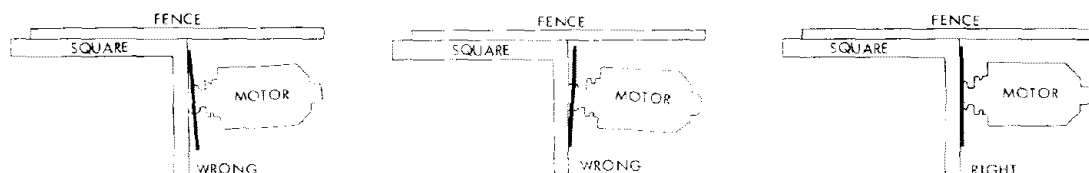
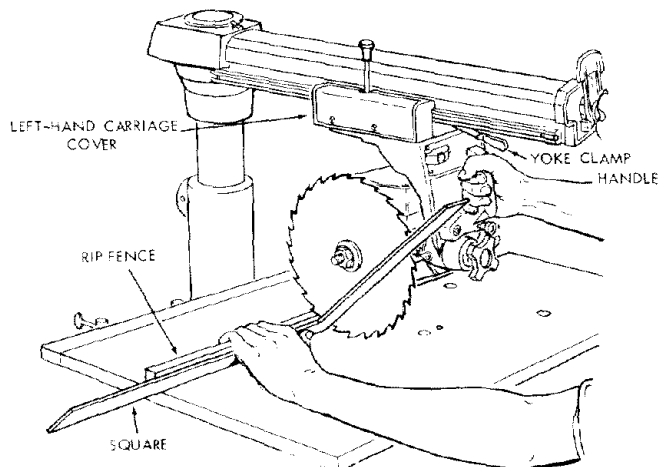

3. To correct for either type of "heel" or "toe" condition proceed as follows:
 - a. Remove left hand carriage cover.
 - b. Loosen the yoke clamp handle.
 - c. Loosen (slightly) the two hex-head screws.
 - d. Rotate the yoke assembly until gap between the saw blade and square is eliminated.
 - e. Lock yoke clamp handle and retighten the two hex-head screws.
 - f. Recheck for "heel" or "toe" and install carriage cover.

NOTE: This alignment procedure will simultaneously set both yoke indexing positions for in and out rip.

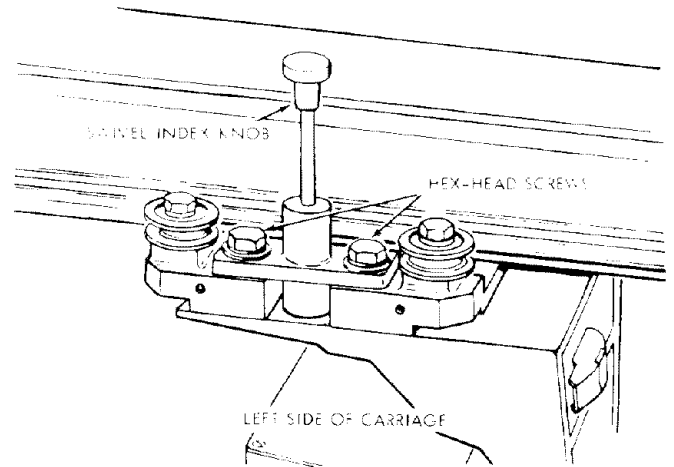

STEP 6

ALIGNMENT OF ANTI-KICKBACK AND SPREADER ASSEMBLY, FOR RIPPING.

WARNING: NEVER POSITION THE GUARD OR ANTI-KICKBACK ASSEMBLY WITH POWER ON; NOR POSITION ANTI-KICKBACK PAWLS BY GRASPING PAWLS OR SPREADER.

1. Check and adjust the spreader as follows:
 - a. Loosen the wing screw and with the "tab" position the anti-kickback and spreader assembly to near the bottom of the blade. Tighten the wing screw.

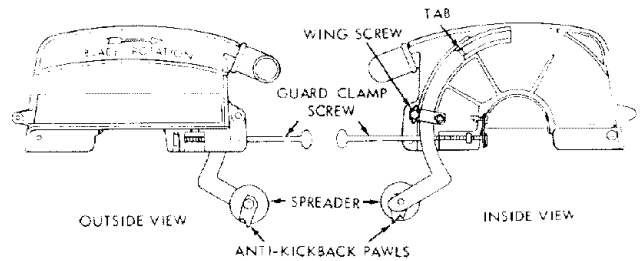

- b. Sight (visually) to check for proper alignment of spreader with saw blade as shown. If the spreader is not aligned, adjust it as follows:
 - (1) Loosen two hex nuts, one on each side of spreader.
 - (2) Rotate hex nuts with fingers until the spreader is directly in line with saw blade.
 - (3) Tighten both hex nuts firmly.

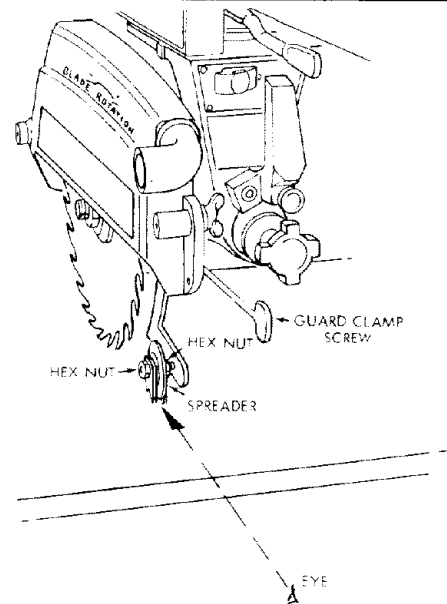

2. INSTALLING AND ADJUSTING RIP SCALE INDICATOR.

NOTE: The rip scales and pointer are intended to be used for quick settings. For greater accuracy, take direct measurement between blade and fence.

- a. Remove the right-hand carriage cover.
- b. Using two screws and one twin nut attach rip scale indicator to cover as shown. Do not tighten screws.
- c. Re-install right-hand carriage cover.

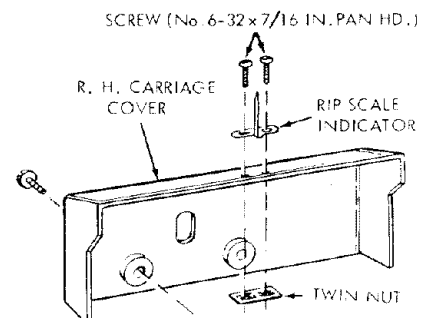

unpacking and assembly

- d. With the fence in its normal position (next to front table), loosen the yoke clamp handle, lift up on swivel latch pin knob and rotate the yoke as shown to index the yoke 90° from the cross cut position. This will locate the saw blade between the motor and the fence. Lock the yoke by tightening yoke clamp handle.
- e. Position carriage until the edge of the blade, when spun by hand, just touches the front face of the fence. The rip-scale indicator should now read "0" inches on lower portion of the Rip scale. If not, loosen screws and shift the indicator until it is aligned with the "0" mark, then tighten the screws.
This adjustment will simultaneously set the out rip scale when rip fence is positioned in its most rearward position.
- f. Loosen yoke clamp handle, lift up on swivel latch pin knob and return the blade to the 90° position.

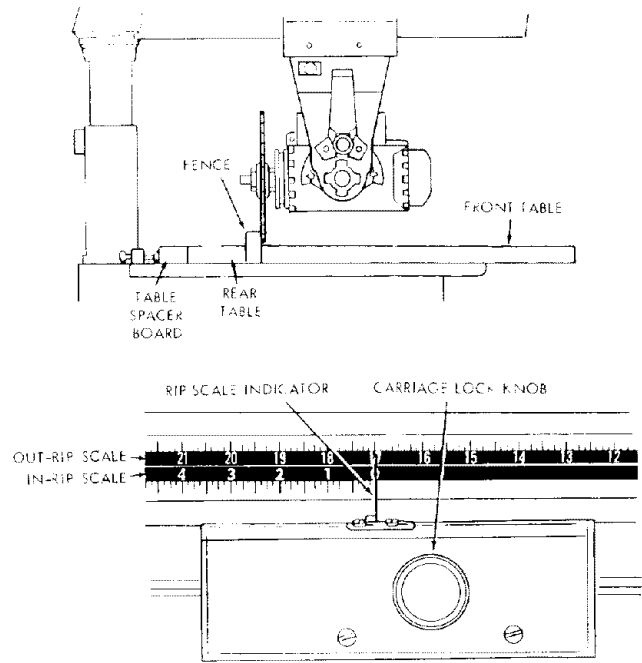

operating controls

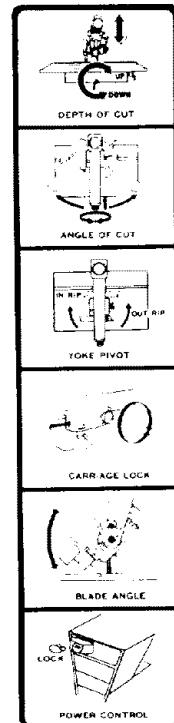
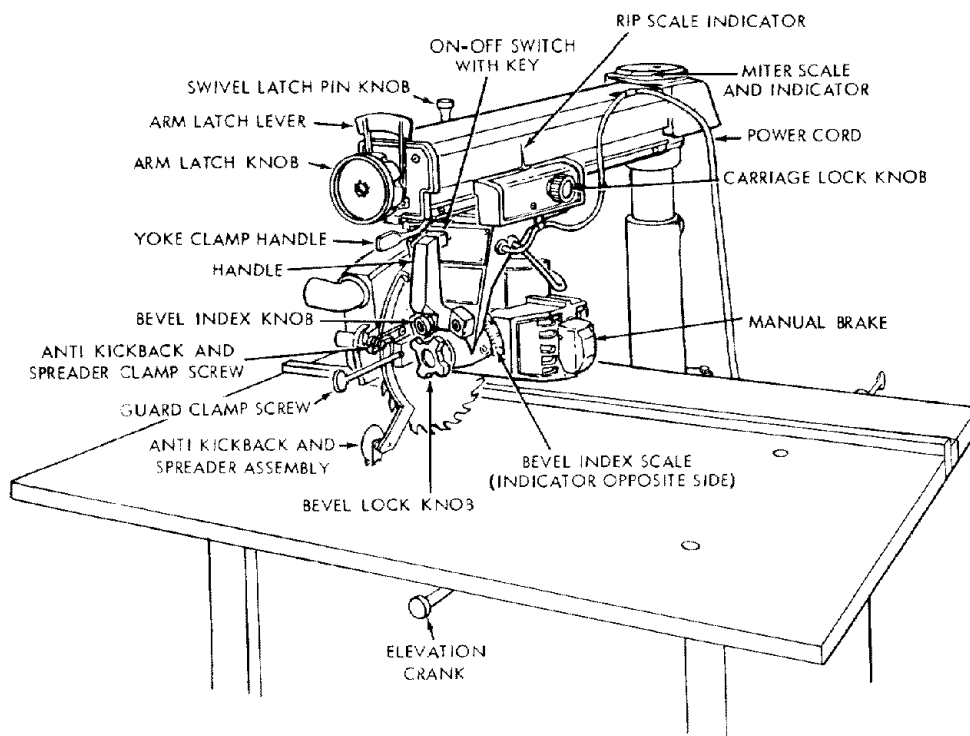

KNOW LOCATIONS AND FUNCTIONS OF CONTROLS

A series of six diagrams is located on the top surface of the radial arm. These designate the controls that must be used in basic set-ups and operating procedures. You should become familiar with these diagrams and the operating instructions that follow, before operating your saw.

1. Depth of Cut

- a. The diagram shows the elevation crank which is used to raise and lower the saw blade.
- b. Clockwise rotation raises the blade ... counterclockwise rotation lowers it. One complete turn of the handle will raise or lower the saw blade 1/8-inch.

2. Angle of Cut

- a. Two controls are involved in releasing, securing and indexing the angle of the radial arm. These are: the arm-latch handle and arm-latch knob.
- b. The arm is unlocked from any position by a slight counterclockwise rotation of the arm latch knob and is locked in any desired miter position by rotating the arm-latch knob clockwise until tight. The radial arm has positive stops at 0° and 45° left and right, and is released from these index positions by unlocking the arm-latch knob 1/4-turn, and pulling out the arm-latch lever.
- c. For the most positive and accurate settings at the index positions, the following is recommended:
 - (1) If the radial arm is already indexed, rotate the arm-latch knob 1/4-turn counterclockwise from the locked position, pull out the arm-latch lever, and move the radial arm off the index position. Release the arm-latch lever.
 - (2) Move the radial arm into the desired index position (do not bump or jar it) and push on the arm-latch lever solidly with the palm of your hand. This is very important as it ensures proper seating of the arm lock pin in the arm latch, thus always setting the arm at the correct position.

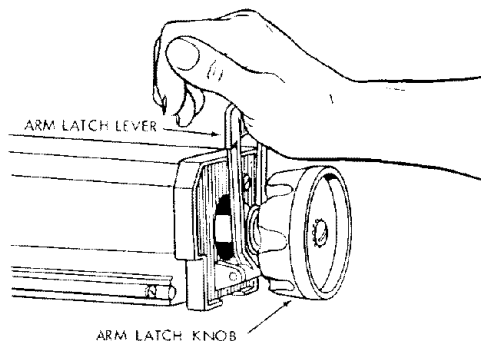

- (3) Lock the radial arm by rotating the arm-latch knob clockwise until tight.

3. Yoke Pivot

- a. Two controls are used in this operation. They are: the swivel latch-pin knob and the yoke clamp handle.
- b. A swivel latch pin automatically indexes the yoke at each 90° position. Lift the spring-loaded swivel latch-pin knob to release this pin.
- c. The yoke clamp handle locks the yoke to the carriage in any position. Pull the handle forward to release the yoke; push the handle rearward to secure the yoke.

4. Carriage Lock

- a. The carriage lock knob is rotated clockwise to secure the carriage on the radial arm, and counterclockwise to release it.
- b. When performing a square or miter-angle crosscut, the carriage lock knob must be rotated counterclockwise until the carriage is free to travel along the arm. This knob should be tightened except when the operator is ready to grasp the bevel index handle and make a cut.

5. Blade Angle

- a. The two controls used in angular positioning and indexing of the motor, to provide the desired saw-blade (bevel) angle, are: bevel lock knob and bevel-index knob.
- b. The bevel-index scale indicates the angular position of the motor with respect to horizontal, from 0° to 90° in either vertical position.
- c. The bevel index knob automatically indexes the motor at 0°, 45° and 90° up and down. Pull out on the knob while positioning the blade, then release it. At any other position it does not engage.
- d. The bevel lock knob locks the motor to the yoke when the motor is in any position. Rotate the knob clockwise to lock, counterclockwise to unlock.

6. On-Off Switch and Key

The On-Off Switch has a locking feature. THIS FEATURE IS INTENDED TO PREVENT UNAUTHORIZED AND POSSIBLE HAZARDOUS USE BY CHILDREN AND OTHERS.

- a. Insert key into switch lock.

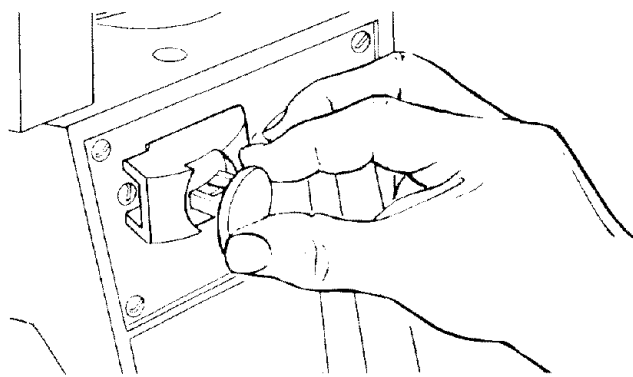

- b. Insert finger under end of switch lever and pull end out, to turn switch on.

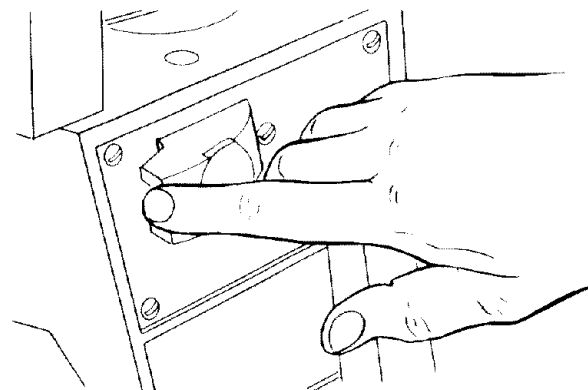

operating controls

- c. Push lever in – with thumb – to turn switch off.

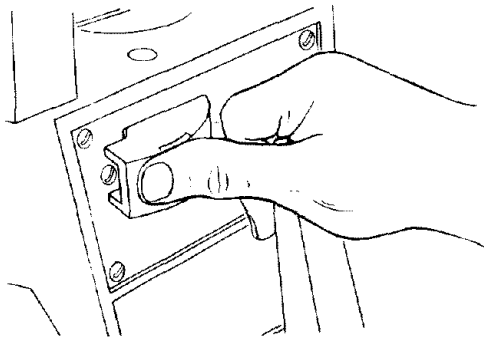

- d. **WARNING: THIS LOCKING FEATURE IS PROVIDED TO PREVENT UNAUTHORIZED USE OF YOUR SAW. ALWAYS REMOVE THE KEY AND KEEP IT IN A SAFE PLACE. TO REMOVE KEY, HOLD THUMB ON END OF LEVER TO KEEP SWITCH IN "OFF" POSITION AND PULL KEY STRAIGHT OUT.**

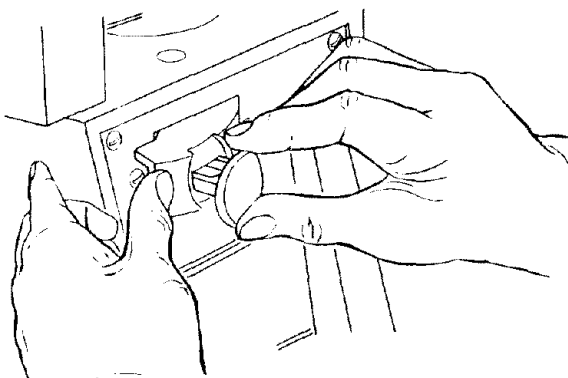

WARNING: FOR YOUR OWN SAFETY ALWAYS LOCK THE SWITCH "OFF" WHEN SAW IS NOT IN USE. REMOVE KEY AND KEEP IT IN A SAFE PLACE . . . ALSO IN THE EVENT OF A POWER FAILURE (ALL YOUR LIGHTS GO OUT) TURN SWITCH OFF. LOCK IT AND REMOVE THE KEY THIS WILL PREVENT THE SAW FROM STARTING UP AGAIN WHEN THE POWER COMES BACK ON.

7. The Manual Motor Brake.

- a. The manual brake is located on the motor shaft at the right-hand end of motor.

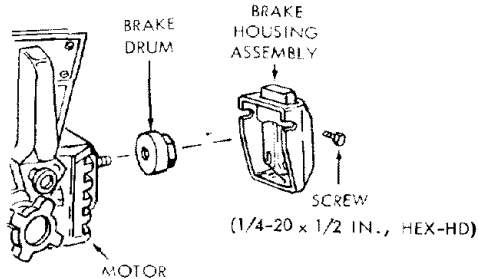

- b. Pressing on the brake button with finger or thumb, after turning off the ON-OFF switch, will greatly reduce blade coasting time.

NOTE: When using an accessory such as a drill chuck attached to end of motor shaft, it will be necessary to remove the brake housing assembly and brake drum. Be sure to re-install the brake after removing the accessory.

Use only the following recommended accessories:

Drill chuck, Sanding drum, and Router adapter.

CAUTION: The sawblade, dado, or cutting tool must be removed from the saw arbor before using the accessory shaft. NEVER operated the saw with cutting tools (including sanding accessories) installed on both ends of the saw arbor.

POSITIONING ANTI-KICKBACK AND SPREADER ASSEMBLY, FOR RIPPING

WARNING: NEVER POSITION THE GUARD OR ANTI-KICKBACK ASSEMBLY WITH THE POWER ON. NEVER POSITION THE ANTI-KICKBACK PAWLS BY GRASPING THE PAWLS OR SPREADER.

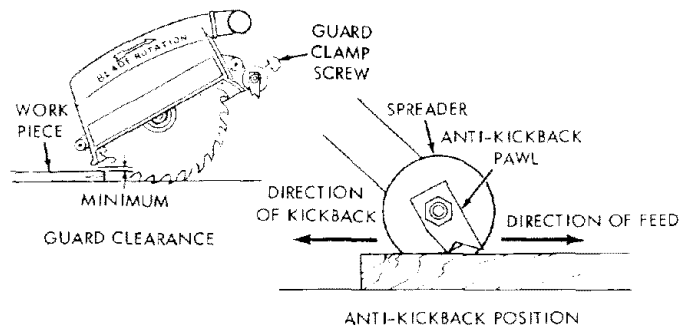

(Make sure by trial before starting the cut that the Anti-Kickback Pawls will stop a Kick-back once it has started)

For all crosscutting operations (those operations in which the carriage is traveled along the radial arm to feed the saw blade into the workpiece) both the guard and anti-kickback and spreader assembly must be elevated to clear the workpiece or the fence, whichever is higher.

1. The blade guard is positioned by loosening the guard clamp screw and rotating the guard so that it just clears the workpiece as shown.
2. The anti-kickback and spreader assembly is used during ripping operations and is adjustable to accommodate the thickness of the board being ripped. A wing nut in the guard secures the assembly.
3. Loosen the wing screw and with the tab provided, position the anti-kickback and spreader assembly until the pawls assume the approximate position shown. Tighten the wing screw.

Before making the cut, check the effectiveness of the anti-kickback pawls by sliding the workpiece under the pawls in the direction of feed and then attempting to slide it in the reverse direction – the direction of kickback. If the pawls do not catch, readjust.

PRECISION INDEXING

Experienced operators of precision equipment, such as this Craftsman Radial Saw, normally acquire the habit of indexing the machine in one direction only, whenever a new setting is made in preparation for a different operation. For example: when moving the radial arm to a new position, it is advisable to move it slightly past the desired index position, then return it slowly and carefully to latch and lock it. Swivel indexing and bevel indexing can be accomplished in a similar manner. This indexing technique tends to neutralize any stresses imposed upon saw components and contributes to the high degree of accuracy the saw is capable of producing when operated expertly.

basic saw operations

Basic saw operations are summarized into six categories, explained and illustrated in the following paragraphs. A manual entitled "The Radial Saw" is available at your nearest Sears Retail Store or Catalog Order House. This manual contains considerable data and project ideas applicable to the radial saw.

NOTE: Refer to paragraphs under "OPERATION" for illustrations and descriptions of controls.

REQUIREMENTS FOR CROSSCUT

Board (stationary) position against rip fence (guide) and laying flat on table top.

(OPERATIONS 1 THROUGH 4)

1. Arbor nut must be tight and saw blade guard installed in horizontal position with anti-kickback device in full up position.
2. Arm latch handle (knob) must be tight.
3. Adjust the anti-kickback assembly so the pawls just clear the workpiece.
4. Work must be held firmly against table and fence. For workpieces thicker than the fence is high, it is recommended that a higher fence be cut (at least workpiece thickness) and inserted for that operation being performed. Always place the fence in the most forward position (farthest from the column support) compatible with the workpiece being processed and the operation being performed. With the carriage fully retracted, the blade should not contact the workpiece when placed against the fence, within the stated capacities of your saw.
5. Blade should be sharp and correctly set.
6. Hands must be kept well away from saw blade.
7. Yoke clamp handle must be in locked position.
8. Bevel index knob must be tight.
9. Blade should cut into the table or plywood cover not more than 1/32 inch.
10. Pull the saw forward just far enough to sever the lumber. It is dangerous if the blade has been pulled too far out beyond the piece being cut. When it is returned it can pick up the right hand piece and throw it over the fence.
11. For operations No. 3 and No. 4, observe additional instructions under paragraph "Operating Controls" "Blade Angle".

OPERATION No. 1 – CROSSCUT

Crosscutting is the process of sawing the workpiece by pulling the saw blade through it and using the fence as a support for the edge of the workpiece. Never crosscut free-hand.

WARNING: BEFORE CROSSCUTTING, MAKE SURE THE ARM LATCH, BEVEL LOCK AND YOKE CLAMP ARE ALL SECURED. NEVER USE A LENGTH STOP OR A FIXED GUIDE ON THE FREE END OR EDGE OF A WORKPIECE. (SEE INSTRUCTION 7 UNDER "SAFETY INSTRUCTIONS TO OPERATOR".) DO NOT CROSSCUT WORKPIECES THAT PLACE YOUR HANDS CLOSE TO THE PATH OF THE SAW BLADE. WHEN MORE EXPERIENCE IS GAINED BY USING THE SAW, IT WILL BE NOTICED, THAT WHEN PULLING THE SAW TOWARD YOU DURING CROSSCUTTING, THE BLADE TENDS TO FEED ITSELF THROUGH THE WORK DUE TO THE ROTATION OF THE BLADE AND THE DIRECTION OF THE FEED. THEREFORE, THE

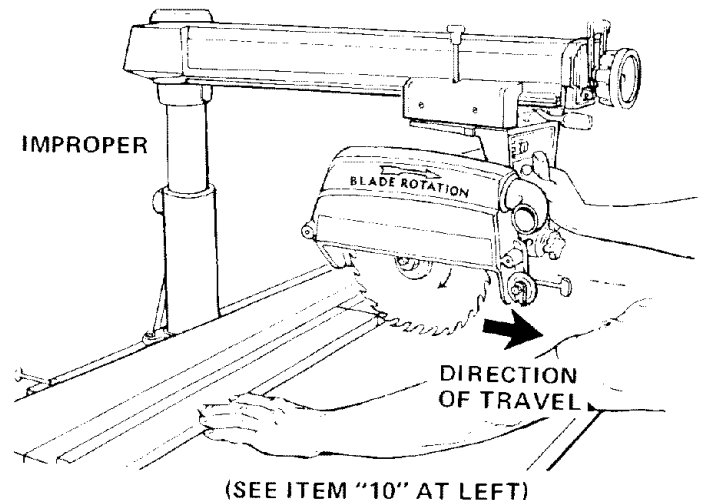
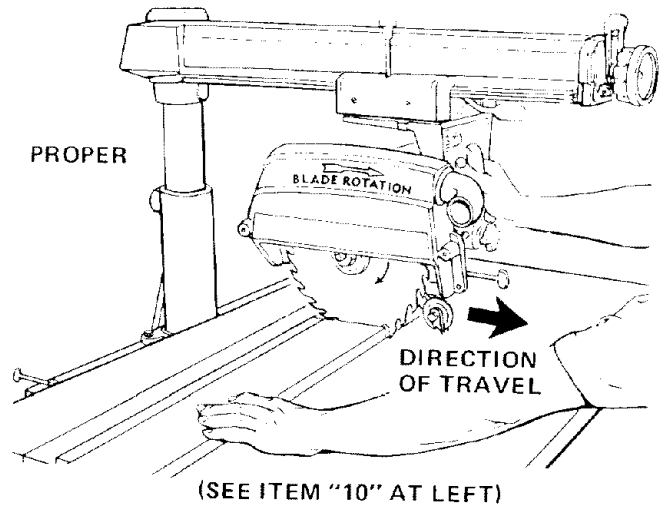
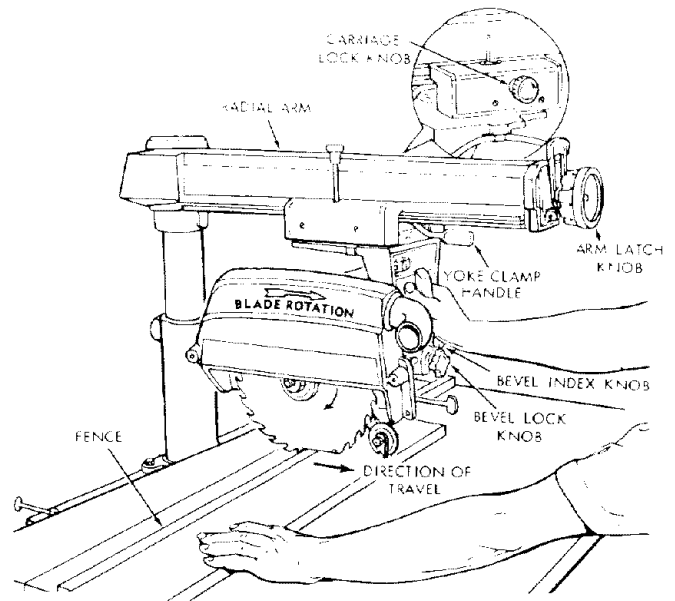

OPERATOR SHOULD DEVELOP THE HABIT OF HOLDING HIS RIGHT ARM STRAIGHT FROM THE SHOULDER TO THE WRIST.

REPETITIVE CROSSCUTTING

Clamp a "C" clamp (min. 6 inch) using a wood block on each side of the arm. This will limit the carriage travel beyond the position necessary to complete the crosscut operation.

basic saw operations

OPERATION No. 2 – MITER CROSSCUT

Miter crosscutting is the process of sawing a board at any angle other than a 90° (square) cut. The 45° miter angle is a popular one, since two boards cut to 45° can be assembled to form a 90° corner for producing a square or rectangular frame. The radial arm is set to the desired angle of cut; yoke and bevel settings indexed at 0° (and locked) as in square crosscutting. The board being cut is held firmly against the fence (guide) and the carriage pulled forward along the radial arm to perform the desired cut. As in "Operation No. 1", the carriage should be returned to full rear position and the saw blade allowed to come to a complete stop before removing the boards from saw table.

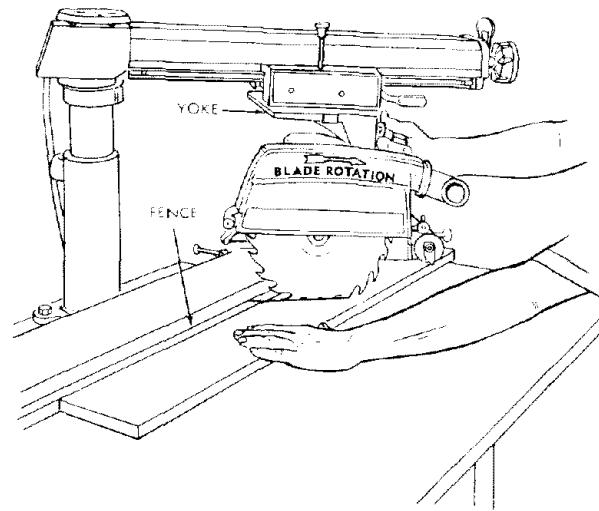

OPERATION No. 3 – BEVEL CROSSCUT

Bevel crosscutting is the process of sawing at 90° (square) across the board with the saw blade set at an angle other than 90° to the saw table. The radial arm and yoke are indexed at 0° and locked, but the bevel is set to the desired angle of cut. The board is held firmly against the fence and the carriage pulled forward along the radial arm to produce the cut. The carriage should be returned to full rearward position and the saw blade allowed to come to a complete stop before removing the boards from saw table.

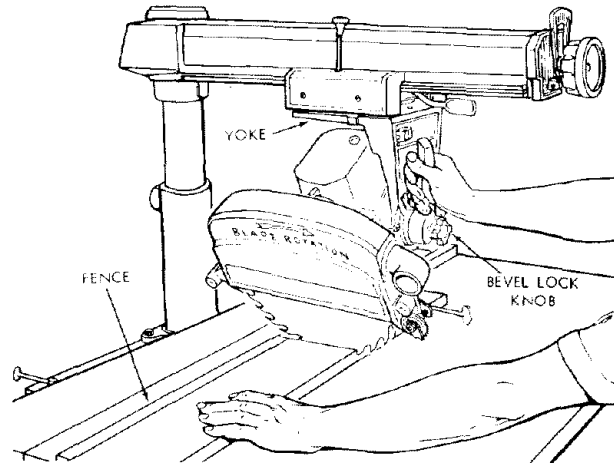

OPERATION No. 4 – COMPOUND CROSSCUT

Compound crosscutting is the combination of miter and bevel crosscuts. The radial arm and bevel are set to produce the desired cut; the yoke is indexed at 0° and locked. The board is held firmly against the fence and the carriage pulled forward along the radial arm to produce the cut. Again, the carriage should be returned to full rearward position and the saw blade allowed to come to a complete stop before removing boards from saw table.

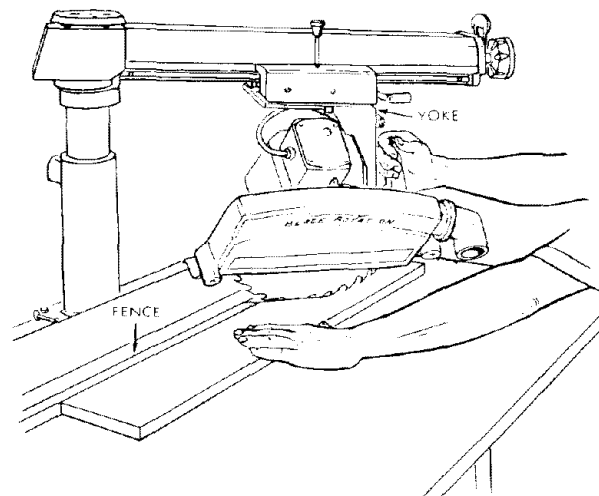

REQUIREMENTS WHEN RIPPING (OPERATIONS 5 AND 6)

1. Carriage lock knob must be tight.
2. Radial arm must be locked in 0° position.
3. Work must be held firmly against table and fence while feeding through.
4. Guard and anti-kickback mechanism must be properly set. Observe instructions in paragraph, "Adjusting Guard, and Anti-Kickback and Spreader Assembly for Ripping."
5. Blade should be sharp and correctly set.
6. When ripping narrow stock, less than 3 inches but more than 1/4 inches between the guard and the fence (guide), use a push stick.

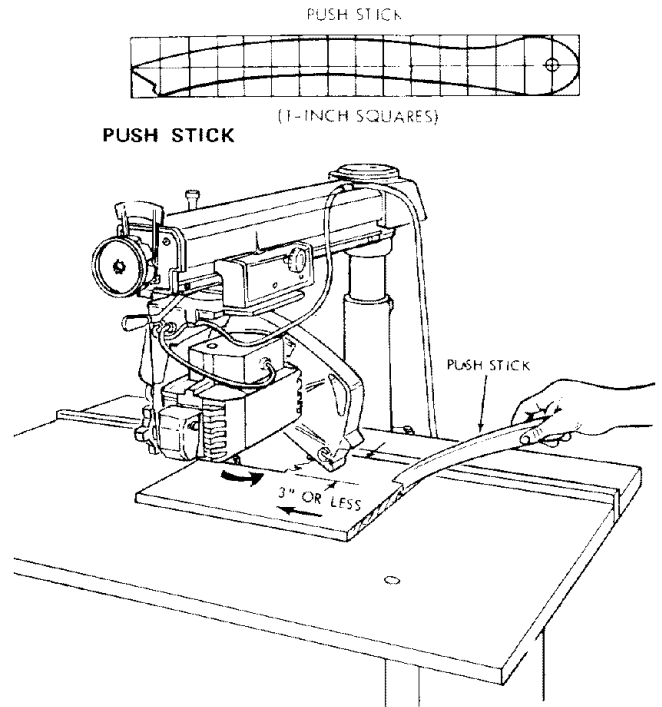

7. When ripping stock 1/4 inch or less between the blade and fence (guide) use a pusher board.

Pusher board should not be less than 3 inches wide and 16 inches long. Nail or glue a 3/4 x 3/4 x 4 inch block to one edge of push board to be used as a grip.

The pusher board should be fed into the blade behind the stock being ripped not more than 8 inches so as not to strike anti-kickback pawls fingers and then pulled back with use of the grip.

8. Hands must be kept well away from saw blade.
9. Saw blade must be parallel to fence, to minimize possibility of kickbacks.

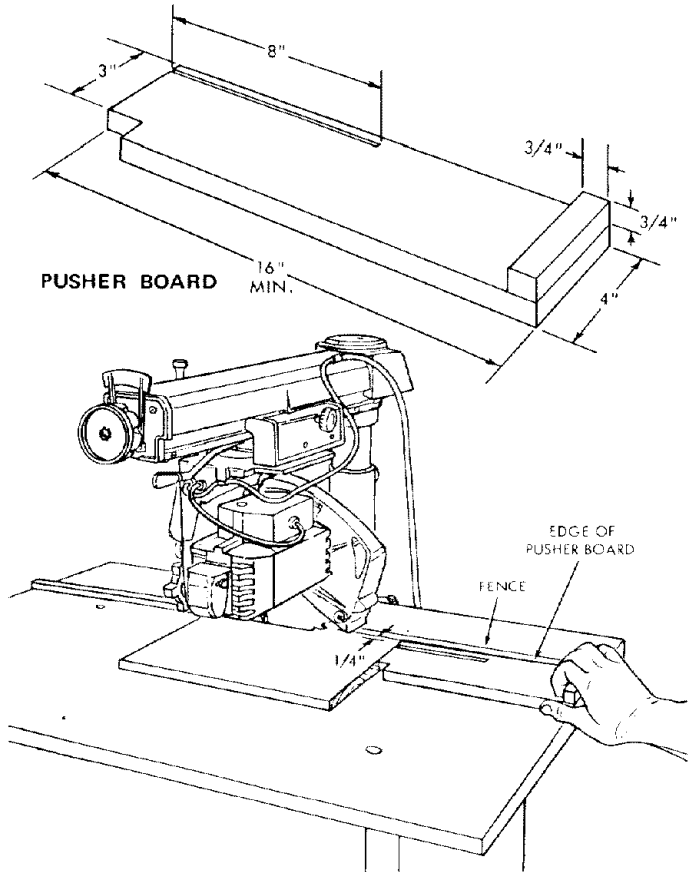

OPERATION No. 5 – OUT-RIPPING AND IN-RIPPING

1. Ripping is the process of sawing the workpiece by feeding it into the saw blade when using the fence as a guide and as a positioning device to obtain the desired width of cut.

WARNING: NEVER RIP FREE-HAND. BEFORE RIPPING, MAKE SURE THE GUARD, SPREADER AND ANTI-KICKBACK PAWLS ARE SET UP PROPERLY. ALSO, MAKE SURE THE SAW BLADE IS PARALLEL WITH THE FENCE. NEVER RIP WORKPIECES SHORTER THAN THE SAW BLADE DIAMETER.

basic saw operations

2. Since the work is pushed along the fence, it must have a reasonably straight edge in order to make sliding contact with the fence. Also, the work must make solid contact with the table, so that it will not wobble. Provide a straight edge, even if this means temporary nailing of an auxiliary straight-edged board to the work. If the workpiece is warped, turn the hollow side down.
3. Always use the saw guard and make sure the spreader is correctly aligned with the saw kerf. Wood cut with the grain tends to spring the kerf closed and bind the blade and a kickback could occur.
4. Stand a little to one side of center to avoid being sprayed with sawdust and to be clear of work in case of kickback.
5. When ripping short or narrow work, always use a push stick applied to the section of the workpiece between the blade and fence . . . push the work past the blade so it is clear of the blade. This procedure will minimize the possibility of kickbacks.

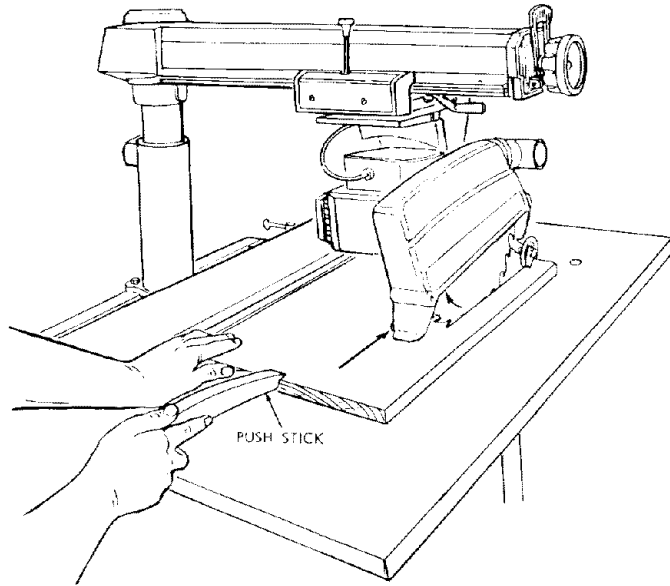

In-Ripping. The radial arm and bevel are indexed at 0° and locked, but the yoke is turned 90-degrees in a clockwise direction (viewed from above) from the crosscut position. Thus, when standing in front of the saw, the blade would be rotating counterclockwise. After positioning the guard and anti-kickback mechanism the workpiece is fed from the right-hand side of the saw. The "In-Rip" scale is on the right-hand side of radial arm.

Out-Ripping. The radial arm and bevel are indexed at 0° and locked, but the yoke is turned 90-degrees in a counterclockwise direction (viewed from above), from the crosscut position. When standing in front of the saw, blade would be rotating clockwise. After positioning the guard and anti-kickback mechanism the workpiece is fed from the left-hand side of the saw, as shown in figure 58. The "Out-Rip" scale is on the right hand side of radial arm.

OPERATION No. 6 – BEVEL RIPPING

Bevel ripping is either in-ripping or out-ripping as described above, except the saw blade is tilted out of perpendicular to the saw table surface. The radial arm is indexed at 0° and locked, the bevel is set to the desired bevel angle and the yoke is positioned for in-ripping (saw blade at rear) or out-ripping (saw blade at front), as required. All requirements and observations applicable to normal ripping operations also apply to bevel ripping.

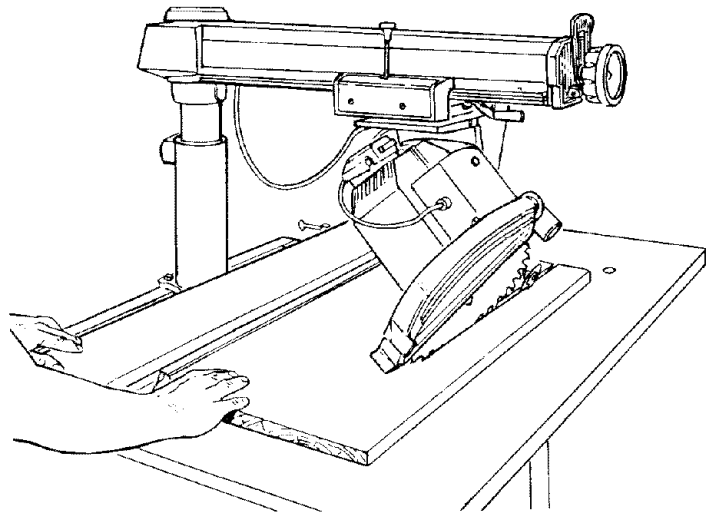

DADOING

Instructions for operating the Dado Head are contained in booklet furnished with the Dado Head.

The saw arbor is designed for dado heads up to 13/16 inches wide. Do not install a wider dado head on the arbor. Take several passes if required dado cut exceeds 13/16 inch.

When installing the dado head on the arbor, ALWAYS install the inside "loose collar" first. Be sure the teeth of the chippers are placed to fall in blade gullets, and chippers are approximately equally spaced around the arbor.

DO NOT install the outside loose collar. Make sure the arbor nut is tight. Install the arbor next directly against the outer blade of dado head.

For best results and to avoid excessive load on the motor, NEVER CUT A 13/16" WIDE DADO, DEEPER THAN 3/4" IN ONE PASS.

MOLDING/SANDING

Instructions for operating the Molding Head are contained in a booklet furnished with the Molding Head.

For use of Molding Head Cutter or Drum Sander the rear table requires an opening for clearance. Cut this opening as shown.

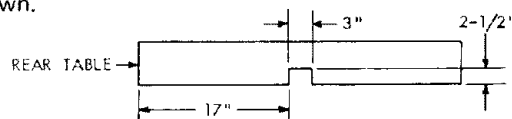

electrical connections

POWER SUPPLY

1. Motor Specifications

The A-C motor used in this saw is a capacitor-start, non-reversible type having the following specifications:

Voltage	120
Amperes	12.5
Hertz (cycles)	60
Phase	Single
RPM	3450
Rotation as viewed from saw blade end	Clockwise

CAUTION: YOUR SAW IS WIRED FOR 120V OPERATION. CONNECT TO A 120V, 15-AMP. BRANCH CIRCUIT AND USE A 15-AMP., TIME-DELAY FUSE OR CIRCUIT BREAKER.

WARNING: DO NOT PERMIT FINGERS TO TOUCH THE TERMINALS OF PLUGS WHEN INSTALLING OR REMOVING THE PLUG TO OR FROM THE OUTLET.

WARNING: IF NOT PROPERLY GROUNDED THIS POWER TOOL CAN INCUR THE POTENTIAL HAZARD OF ELECTRICAL SHOCK, PARTICULARLY WHEN USED IN DAMP LOCATIONS, IN PROXIMITY TO PLUMBING, OR OUT OF DOORS. IF AN ELECTRICAL SHOCK OCCURS THERE IS THE POTENTIAL OF A SECONDARY HAZARD SUCH AS YOUR HANDS CONTACTING THE SAW BLADE.

This power tool is equipped with a 3-conductor cord and grounding type plug which has a grounding prong, approved by Underwriters' Laboratories and the Canadian Standards Association. The ground conductor has a green jacket and is attached to the tool housing at one end and to the ground prong in the attachment plug at the other end.

This plug requires a mating 3-conductor grounded type outlet as shown.

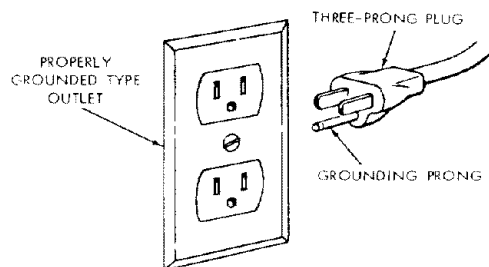

If power cord is worn or cut, or damaged in any way, have it replaced immediately.

If the outlet you are planning to use for this power tool is of the two prong type **DO NOT REMOVE OR ALTER THE GROUNDING PRONG IN ANY MANNER.** Use an adapter as shown and always connect the grounding lug to known ground.

It is recommended that you have a qualified electrician replace the TWO prong outlet with a properly grounded THREE prong outlet.

An adapter as shown below is available for connecting plugs to 2-prong receptacles. The green grounding lug extending from the adapter must be connected to a permanent ground such as to a properly grounded outlet box.

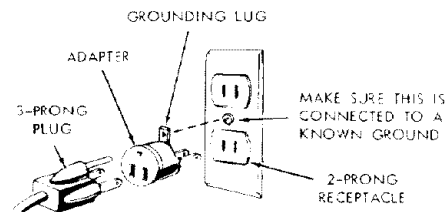

NOTE: The adapter illustrated is for use **only** if you already have a properly grounded 2-prong receptacle. Adapter is not allowed in Canada by the Canadian Electrical Code.

MOTOR SAFETY PROTECTION

NOTE: This motor should be blown out, or "vacuumed", frequently to prevent sawdust interference with normal motor ventilation.

1. This tool should be connected to a 120 volt, 15 amp branch circuit with a 15 amp time delay fuse or circuit breaker. Failure to use the proper size fuse can result in damage to the motor.
2. If the motor fails to start, turn the power switch to the off position immediately. **UNPLUG THE TOOL.** Check the saw blade to insure that it turns freely and that its teeth are not wedged into the table top. After the blade has been freed, try to start the motor again. If, at this point, the motor still fails to start, refer to the "Motor Trouble-Shooting Chart."
3. If the motor should suddenly stall while cutting wood, the power switch should be turned off, the tool unplugged and the blade freed from the wood. The motor may now be restarted and the cut finished.
4. Frequent opening of fuses or circuit breakers may result if motor is overloaded, or if the motor circuit is fused differently from recommendations. Overloading can occur if you feed too rapidly or if your saw is misaligned so that the blade heels. **Do not** use a fuse of greater capacity without consulting a qualified electrician.
5. Although the motor is designed for operation on the voltage and frequency specified on motor nameplate, normal loads will be handled safely on voltages not more than 10% above or below the nameplate voltage. Heavy loads, however, require that voltage at motor terminals equals the voltage specified on nameplate.
6. Most motor troubles may be traced to loose or incorrect connections, overloading, reduced input voltage (such as small size wires in the supply circuit) or to an overly-long supply circuit. Always check the connections, the load and the supply circuit, whenever the motor fails to perform satisfactorily. Check wire sizes and lengths with the table following.

WIRE SIZES

The use of any extension cord will cause some loss of power. To keep this to a minimum and to prevent over-heating and motor burn-out, use the table below to determine the minimum wire size (A.W.G.) extension cord. Use only 3 wire extension cords which have 3 prong grounding type plugs and 3-pole receptacles which accept the tools plug.

Length of the Conductor	Wire Size Required (American Wire Gauge Number) 120 Volt Line
Up to 100 feet	No. 12
100 feet to 200 feet	No. 8
200 feet to 400 feet	No. 6

NOTE: For circuits of greater length, the wire size must be increased proportionately in order to deliver ample voltage to the saw motor.

trouble-shooting

WARNING: REMOVE POWER CORD FROM POWER SOURCE BEFORE TROUBLE SHOOTING.

Even' though the finest materials and precision workmanship have been incorporated into your Craftsman saw, it is reasonable to expect some wear after long periods of use. Sooner or later, the metal to metal parts must wear and will need take-up. Every metal to metal part on your Craftsman saw can be taken up. In this way, the machine can always be kept accurate and just as important, rigid.

The usual operating "troubles" are listed in the following paragraphs with the necessary corrections listed.

1. LOOSENESS OF COLUMN TUBE IN COLUMN SUPPORT – ELEVATION CRANK OPERATES ROUGHLY OR CHATTERS WHEN ROTATED.

Refer to Step two in Alignment Procedure Section. Check for looseness (movement) of column tube in column support.

2. RADIAL SAW DOES NOT MAKE ACCURATE 0° or 45° MITER CROSSCUTS.

- a. Looseness between column tube and column support.

Align as described in Alignment Procedure Section Step Two.

- b. Improper arm indexing at 0° crosscut.

Refer to precision indexing in operating controls section.

- c. Crosscut travel not properly adjusted.

Refer to Step Three in Alignment Procedure Section Squaring Crosscut Travel.

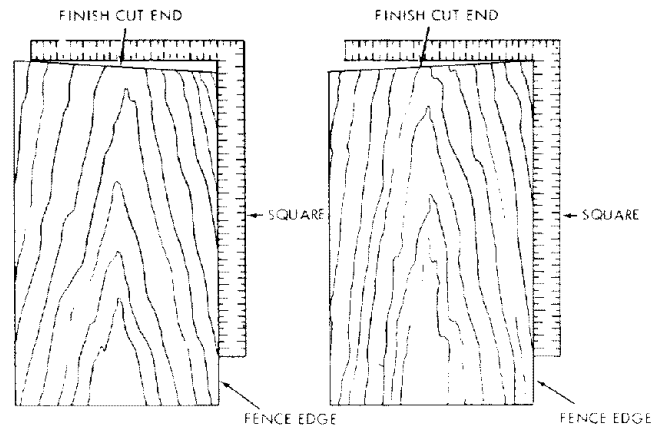

FINISH CUT LOOKS LIKE THIS – 0° CROSSCUT

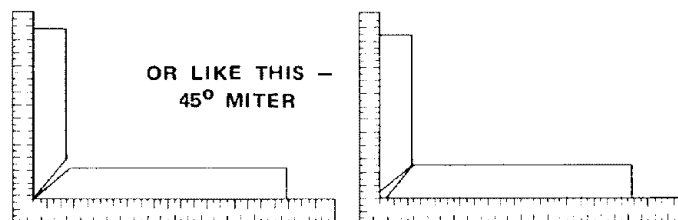

**OR LIKE THIS –
45° MITER**

3. SAW CUTS AT ANGLE – NOT 90° TO TABLE TOP.

- a. Table support channels not properly leveled.
Refer to Step One under Alignment Procedure Section.
- b. Blade not square to work table top.
Refer to Step four in Alignment Procedure Section.

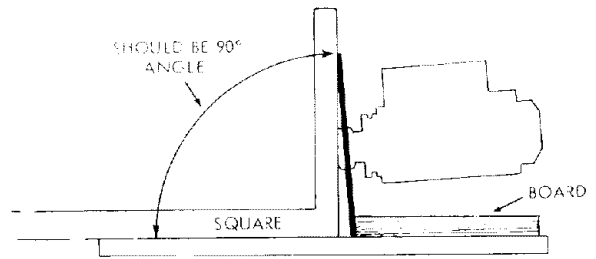

4. BLADE ANGLE (BEVEL) CUTS NOT ACCURATE.

- a. Corrective action is the same as paragraph 3a and b above.
- d. Carriage Bearings Loose
Refer to Step four in Alignment Procedure Section

5. SAW KERF (CUT EDGE) OF STOCK ROUGH – TOOTH MARKS LEFT ON EDGE OF SAW KERF.

NOTE: This condition is commonly called "HEEL" or "TOE".

- a. Crosscutting or Miter Cutting
Heeling will tend to slide the workpiece toward the right along the guide fence, as the cut is being made, and make a square cut almost impossible. A blade with "toe" will tend to slide the board to the left along the fence.
Refer to step 5 under Alignment Procedure Section – "Squaring Blade to Fence".

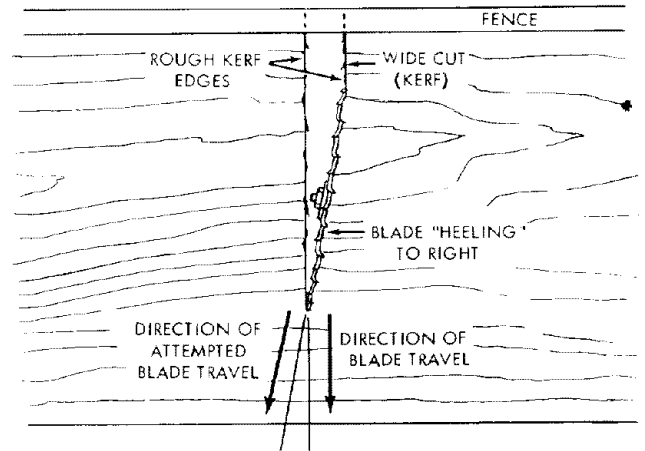

6. WOOD BINDS, SMOKES AND MOTOR SLOWS DOWN OR STOPS WHEN RIPPING.

- a. Dull blade or warped board.
Sharpen or replace the saw blade. Avoid the attempted use of severely warped material.
- b. Radial arm not securely locked in 0° position.
Loosen the arm lock knob and refer to paragraph "Precision Indexing".
- c. Crosscut not properly squared.
Check and align as described in Alignment Procedure Section, Step Two and Three. Squaring crosscut automatically corrects this condition for ripping.
- d. Saw blade heels.
Check and align as described in Alignment Procedure Section, Step Five.

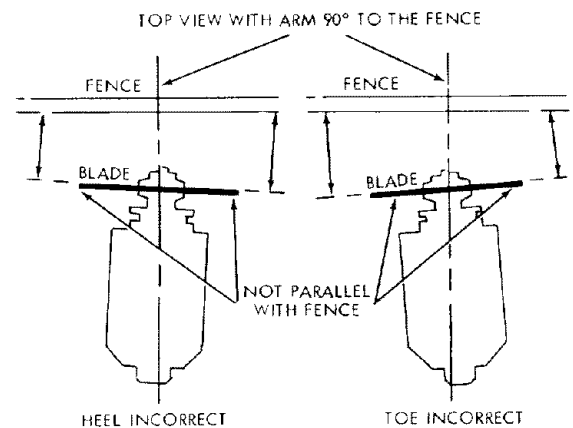

7. BOARD PULLS AWAY FROM FENCE WHEN RIPPING.

- a. Saw blade has toe.
Corrective action is the same as preceding instructions explained in paragraphs D and E.
- b. Anti-kickback and spreader assembly not properly adjusted.
Refer to "Adjusting Guard, Anti-Kickback and Spreader Assembly, For Ripping".

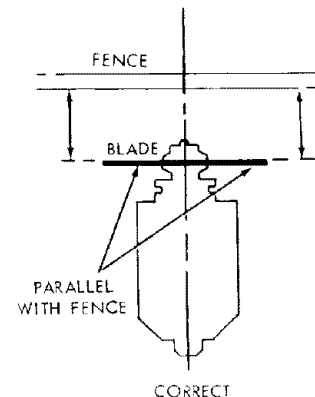

trouble-shooting

8. CARRIAGE BEARINGS LOOSE.

To test for looseness between bearings and tracks on radial arm, perform the following steps.

- a. Remove left-hand carriage cover.
- b. Push the carriage to its full most rearward position.
- c. Finger hold front carriage bearing as shown and apply as much force as possible and at the same time pull carriage forward. If you can stop the bearing from turning it will require adjusting.
- d. Check rear bearing in the same manner and adjust as follows:
 1. Loosen nuts just enough to permit the eccentric screws to turn.
 2. Rotate the eccentric screws a partial turn (left or right) as required to take up looseness.
 3. Hold the heads of eccentric screws in the position established in the preceding step and tighten nuts on underside of carriage. Correct adjustment exists when you cannot keep the bearings from turning.

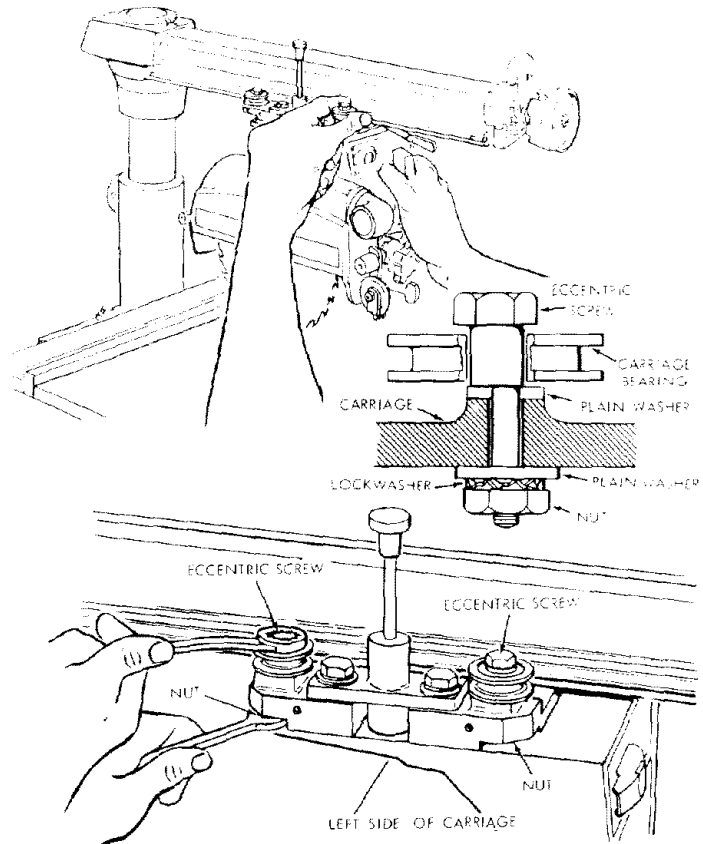

9. YOKE DOES NOT INDEX PROPERLY.

Check for proper yoke indexing noting that the swivel latch pin fits into its detents properly. If swivel latch pin housing screws (located under left hand carriage cover) are loose, readjust blade for "heel" or "toe" as described in Alignment Procedure Section, Step Five.

- e. Locate the index plate locking screw at rear of yoke assembly.

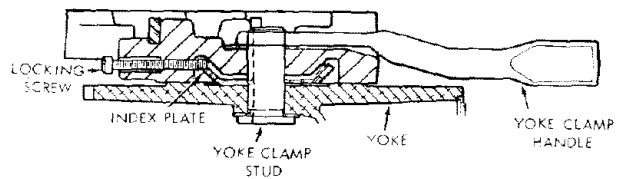

10. YOKE CLAMP HANDLE ADJUSTMENT.

The normal locking position of the yoke clamp handle is parallel with the radial arm. When wear has occurred to permit the handle to strike the yoke before locking, the handle must be adjusted as follows:

- a. Set yoke clamp handle to Normal Locking Position.
- b. Remove carriage stop screw and lockwasher with a 3/16 inch hex-L wrench.

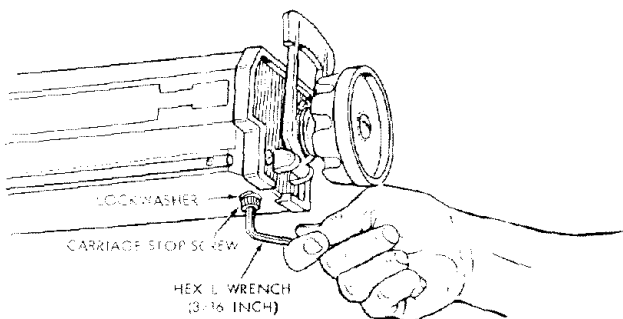

- c. Grasp the carriage assembly, holding it parallel to the radial arm until all carriage bearings are free of their tracks, move it carefully off the end of radial arm.
- d. Rest the motor and carriage assembly on saw work table.

- f. Turn locking screw out at least 1/4-inch from tight position, this frees the index plate which is keyed to the yoke clamp stud.
- g. Loosen yoke clamp handle and, with a screwdriver, rotate the yoke clamp stud clockwise (viewed from bottom) a fraction of a turn.
- h. Tighten yoke clamp handle and, if it still does not tighten at the proper handle position, loosen the handle and rotate the stud an additional fraction of a turn. Two or more trials may be required.
- i. Rotate the locking screw back into tight position to secure the index plate. If the end of the screw does not pass through a slot in index plate, rotate the yoke clamp stud just enough (either direction) to align a slot with end of screw. (The screw tightens against the head when properly locked.)
- j. Hold the motor and carriage assembly parallel to radial arm and start the rear bearings onto the tracks. Continue to hold the assembly parallel to the tracks until the forward bearings are on the tracks.
- k. Slide the carriage rearward on the radial arm and install the carriage stop screw and lockwasher.

MOTOR TROUBLE - SHOOTING CHART

NOTE: Motors used on wood working tools are particularly susceptible to the accumulation of sawdust and wood chips and should be blown out or "vacuumed" frequently to prevent interference with normal motor ventilation.

TROUBLE	PROBABLE CAUSE	SUGGESTED REMEDY
Motor will not run.	1. Low voltage.	1. Check power line for proper voltage.
Motor will not run and fuses "BLOW".	1. Short circuit in line, cord or plug. 2. Incorrect fuse in power line.	1. Inspect line, cord and plug for damaged insulation and shorted wires. 2. Install 15 amp Time Delay Fuse.
Motor fails to develop full power. (Power output of motor decreases rapidly with decrease in voltage at motor terminals. For example: a reduction of 10% in voltage causes a reduction of 19% in maximum power output of which the motor is capable, while a reduction of 20% in voltage causes a reduction of 36% in maximum power output.)	1. Power line overloaded with lights, appliances and other motors. 2. Undersize wires or circuit too long. 3. General overloading of power company's facilities. (In many sections of the country, demand for electrical power exceeds the capacity of existing generating and distribution systems.)	1. Reduce the line load. 2. Increase wire sizes, or reduce length of wiring. 3. Request a voltage check from the power company.
Motor overheats.	1. Excessive feed rate when crosscutting or ripping. 2. Improper cooling. (Air circulation restricted through motor due to sawdust, etc.) 3. Saw blade has "heel".	1. Slow down rate of feed. 2. Clean out sawdust to provide normal air circulation through motor. 3. Refer to Alignment Procedure Section of manual Step Five.
Motor starts slowly or fails to come up to full speed.	1. Low Voltage – will not trip starting switch. 2. Blade teeth wedged into table.	1. Correct low voltage condition. 2. Free blade from table.
Motor stalls (resulting in blown fuses or tripped circuit breakers).	1. Voltage too low to permit motor to reach operating speed. 2. Fuse or circuit breaker do not have sufficient capacity.	1. Correct the low line voltage condition. 2. Replace fuse with 15 amp Time Delay Fuse.
Frequent opening of fuses or circuit breakers.	1. Motor overloaded. 2. Fuse does not have sufficient capacity.	1. Reduce motor load. 2. Replace fuse with 15 amp Time Delay Fuse.

maintenance and lubrication

MAINTENANCE

WARNING: FOR YOUR OWN SAFETY, TURN SWITCH "OFF" AND REMOVE PLUG FROM POWER SOURCE OUTLET BEFORE MAINTAINING OR LUBRICATING YOUR SAW.

When you receive your new Craftsman radial saw, it requires no lubrication. The radial saw has been partially aligned and all bearings are lubricated and sealed for life. In time, however, in order to keep your saw in perfect working order and accurate, it will be necessary to lubricate and realign. In fact, your radial saw needs more of a cleaning than a lubrication.

Make sure the teeth of the ANTI-KICKBACK pawls are always sharp. Relace if not sharp.

LUBRICATION

Your saw is precision built and should be kept clean and properly lubricated. Before describing the various points which may periodically require lubrication, IT IS MORE IMPORTANT TO FIRST MENTION THE VARIOUS POINTS WHICH SHOULD NOT BE LUBRICATED.

NO LUBRICATION REQUIRED

Do not lubricate carriage ball bearings or motor bearings as these are sealed ball bearings and require no added lubrication.

Do not lubricate between radial arm cap and radial arm.

PERIODICALLY LUBRICATE THESE POINTS

Use SAE No. 10W-30 automotive engine oil and refer to Parts List for locations. Apply a few drops of oil along the swivel latch pin only if the pin has a tendency to stick. Remove the left-hand carriage cover and use oil sparingly to prevent it from getting on the ball bearings or races.

A light film of oil should be wiped on the face of the column tube and keyway to lubricate the fit between the column tube, the key and column support.

Apply a few drops of oil to the bearing surfaces of the elevation crank shaft assembly. An oil hole is provided in the elevation shaft bearing bracket to facilitate the lubrication of the bearing support.

The thread on the elevation shaft assembly can be lubricated through the oil hole in the center of the radial arm cap.

CAUTION: Excessive oil at any location will attract airborne dust particles and sawdust.

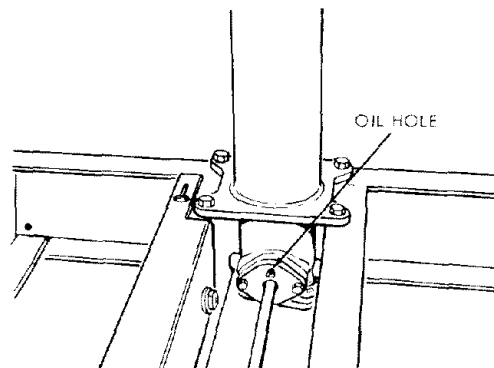

recommended accessories

IN CANADA, SEE YOUR LOCAL SIMPSONS-SEARS STORE
OR CATALOG FOR ACCESSORY SELECTION AND NUMBERS

ITEM	CAT. NO.
Stand	9-22202
Steel Legs	9-22238
Castors	9-22201 — 9-22209
Key Chuck	9-2980
* Molding Head Guard — 7-Inch	9-29524
* Molding Head Guard — 8-Inch	9-29523
Rotary Surface Planer — Carbide Tip	9-29513
Sanding Wheel — 8-Inch	9-2274
Sanding Wheel — 10-Inch	9-22723
Dust Collector	9-29517 — 9-16998
Taper Jig	9-3233
* Satin Cut Dado — 7-Inch	9-3257
* Satin Cut Dado — 8-Inch	9-3253
* Molding Head Single Cutter	9-3215
* Molding Head Three Cutter	9-3221
Sanding Drum — 3-Inch	9-25246
• Lower Retractable Blade Guard	9-29009
“Power Tool Know How Handbook”	
Radial Saw	9-2917
Work Light	9-2481
Router Adapter	9-3239

The above recommended accessories are current and were available at the time this manual was printed.

*Before purchasing or using any of these accessories read and comply with Additional Safety Instruction No. “(D)2” on page 4 of this manual.

- Meets OSHA Requirements as of 8-73

PARTS LIST FOR CRAFTSMAN 10-INCH RADIAL SAW
MODEL NUMBER 113.23112

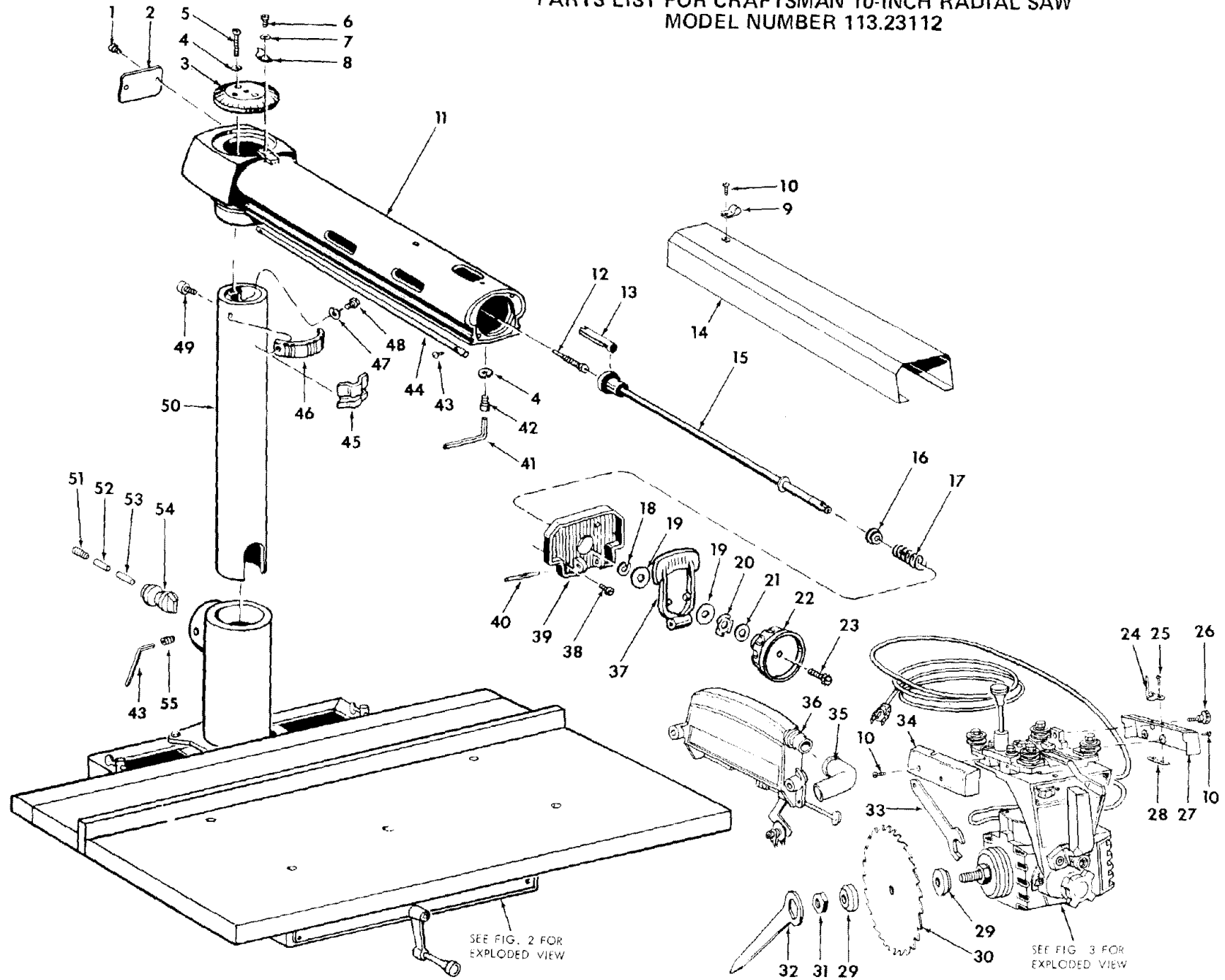

Figure 1

**PARTS LIST FOR CRAFTSMAN 10-INCH RADIAL SAW
MODEL NUMBER 113.23112**

All parts illustrated in Figures 1 through 5 and listed under part numbers may be ordered through any Sears retail mail order store. Order parts by mail from the catalog order store which serves the territory in which you live. In several instances, part numbers are listed for COMPLETE ASSEMBLIES. All parts are shipped prepaid within the limits of the continental United States.

Always order by Part Number – not by Key Number

FIGURE 1

Key No.	Part No.	Description	Key No.	Part No.	Description
1	STD 601103	*Screw, Pan Hd., Type "T", 10-32 x 5/8	29	62445	Collar, Blade
2	63098	Plate, Cover	30	60175	Blade
3	37418	Cap, Radial Arm	31	30495	Nut, Shaft
4	STD 551125	*Lockwasher, 1/4	32	3540	Wrench, Arbor
5	191230	*Screw, Mach., Fil.Hd., 1/4-28 x 1	33	63062	Wrench, Shaft
6	STD 600603	*Screw, Type 23 Pan Sl., 6-32 x 5/16	34	63015	Cover, L.H. Carriage
7	37935	Washer, Fibre .140 x .250 x 1/32	35	63258	Elbow Discharge
8	30559	Indicator	36		Guard Assy. (See Figure 5)
9	30613	Clamp	37	37372	Lever, Arm Latch
10	STD 600805	*Screw, Type 23 Pan Sl., 8-32 x 1/2	38	448039	*Screw, Pan Hd.Type "T" 10-32 x 3/4
11	63542	Arm, Radial	39	63096	Cap, Trim
12	30662	Screw, Arm Lock	40	443151	Pin, Groove
13	30482	Pin, Assy., Arm Latch	41	37911	Wrench, Hex "L", 3/16
14	63543	Trim Asm, Arm	42	216278	*Screw, Soc.Hd.Cap, 1/4-20 x 1/2
15	37370	Shaft Assy., Arm Latch	43	448337	*Screw, Type 23, 10-32 x 5/8 Rd.Hd.
16	30489	Washer, Spring Support	44	63127	Track
17	30490	Spring, Arm Latch	45	30661	Shoe, Brake
18	60044	Ring, Retaining	46	30479	Latch, Arm
19	60076	*Washer, .505 x 1-1/8 x 1/16	47	STD 551137	*Lockwasher, 3/8
20	37373	Washer, Spring	48	STD 523707	*Screw, Cap, 3/8-16 x 3/4
21	60030	*Washer, .505 x 1 x 1/32	49	9421620	*Screw, Cap Soc.5/16-18 x 1/2
22	63410	Knob Assy. 3-1/4	50	63146	Tube, Column
23	STD 522512 & STD 551225	*Screw, Sems.,Sl.Truss Hd.,w/L/washer	51	STD 503105	*Screw, Set,5/16-18 x 1/2 Slotted Cup Pt.
24	63215	Indicator Rip Scale	52	63078	Plug, Back Up (Steel)
25	STD 510605	*Screw Mach.,Pan Hd.6-32 x 7/16	53	63077	Plug, Friction (Nylon)
26	63529	Knob, Rip Lock	54	63079	Key, Column
27	63535	Cover, R.H. Carriage	55	139416	*Screw,Hex.Soc.Cone Pt.,Set 3/8-16 x 5/8
28	30530	Nut, Twin	-	63770	Owners Manual (not illustrated)
			-	63510	Bag of Loose Parts (not illustrated)

*Standard Hardware Item – May be Purchased Locally

+Stock Item – May be Secured through the Hardware Department of most Sears or Simpsons-Sears Retail Stores or Catalog Order Houses.

PARTS LIST FOR CRAFTSMAN 10-INCH RADIAL SAW
 MODEL NUMBER 113.23112

repair parts

30

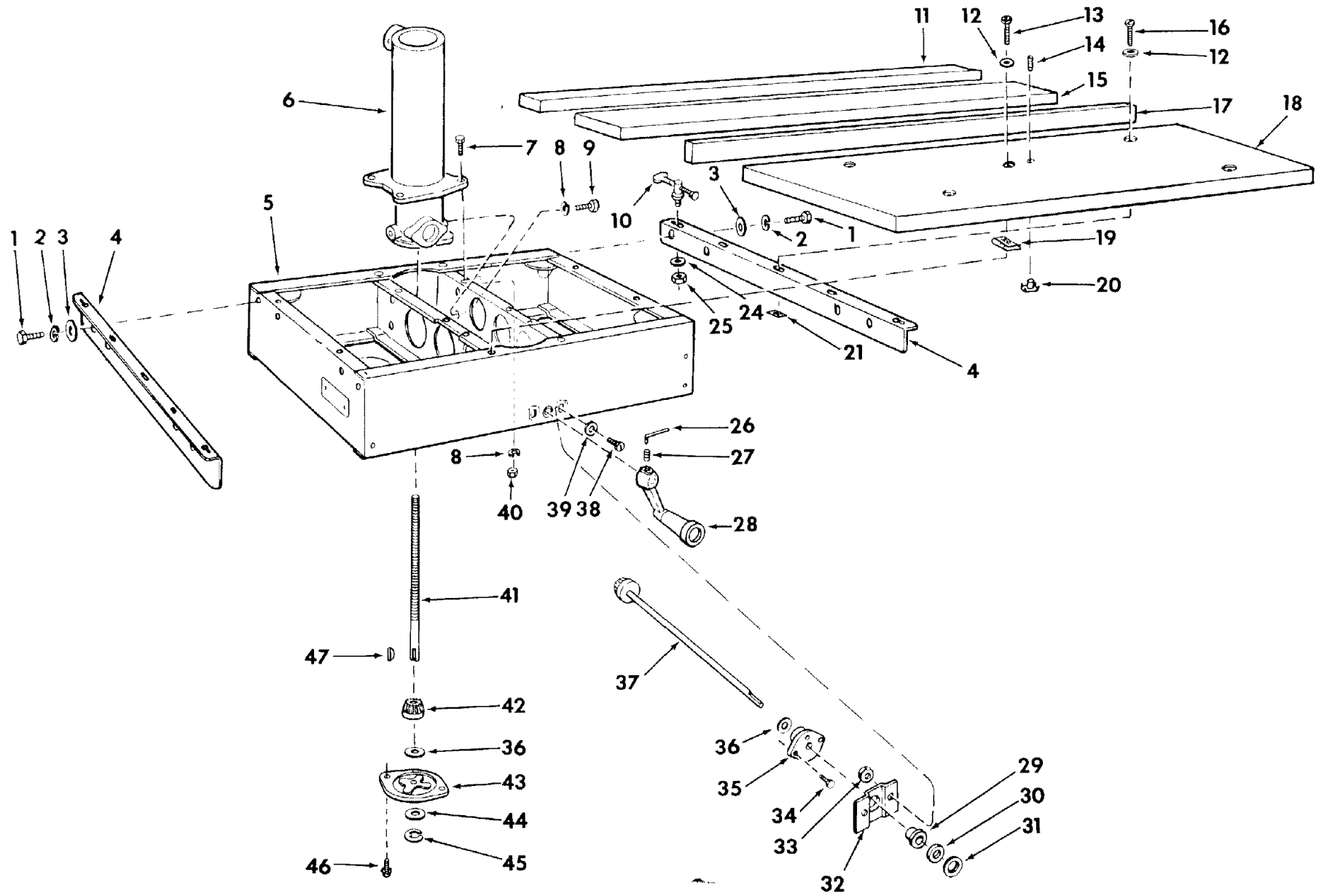

Figure 2

**PARTS LIST FOR CRAFTSMAN 10-INCH RADIAL SAW
MODEL NUMBER 113.23112**

FIGURE 2

Key No.	Part No.	Description
1	STD 523106	*Screw, Mach.Hex.Ind.Hd.,5/16-18 x 1/2
2	STD 551131	*Lockwasher, 5/16
3	STD 551031	*Washer, 11/32 x 7/8 x 1/16
4	63582	Channel, Table Mounting
5	37383	Base
6	63431	Support, Column
7	STD 523712	*Screw, Mach.Hex.Ind.,3/8-16 x 1-1/8
8	STD 551137	*Lockwasher, 3/8
9	STD 523707	*Screw, Mach.Hex.,3/8-16 x 5/8
10	63536	Clamp, Table
11	63571	Table, Spacer
12	60128	*Washer, 17/64 x 5/8 x 1/32
13	60057	*Screw, Pan Sl., 1/4-20 x 1-1/4
14	STD 502505	*Screw, Set, Slotted Cup Pt., 1/4-20 x 1/2
15	63570	Table, Rear
16	STD 512510	*Screw, Mach., 1/4-20 x 1
17	63522	Fence, Rip
18	63569	Table, Front
19	37530	Nut, "U" Clip, 1/4-20
20	37384	Tee Nut
21	60310	Nut, Speed
24	60188	Washer, 21/64 I.D.

Key No.	Part No.	Description
25	STD 541431	Nut, Lock, 5/16
26	37887	Wrench, Hex. "L", 1/8
27	STD 502503	*Screw, Set, 1/4-20 x 3/8,Soc.Hd.Cup Pt.
28	63434	Crank Assy. (Includes Key No. 27)
29	63435	Bushing
30	30604	Washer, Oil
31	60080	*Washer, .515 x 7/8 x 1/32
32	63436	Bracket, Bearing
33	STD 541425	Nut, Lock, 1/4
34	448649	*Screw, Type 23, Hex.Hd., 1/4-20 x 3/4
35	30510	Bracket, Elevation Shaft Bearing
36	60300	Washer, End Play
37	30508	Shaft Assy., Elevation Crank
38	STD 512505	*Screw, Mach., Pan Hd., 1/4-20 x 1/2
39	60106	*Washer, .266 x .562 x 3/64
40	STD 541037	*Nut, Hex,3/8-16 x 9/16 x 21/64
41	63498	Shaft, Elevation
42	63499	Gear, Bevel
43	37428	Plate, Retaining
44	63500	Washer, Thrust
45	60319	Ring, Retaining, 11/32
46	423561	*Screw,Sems Hex Ind.Hd.,5/16-18 x 7/8
47	STD 580018	Key, No. 5 Woodruff

*Standard Hardware Item -- May be Purchased Locally

PARTS LIST FOR CRAFTSMAN 10-INCH RADIAL SAW
MODEL NUMBER 113.23112

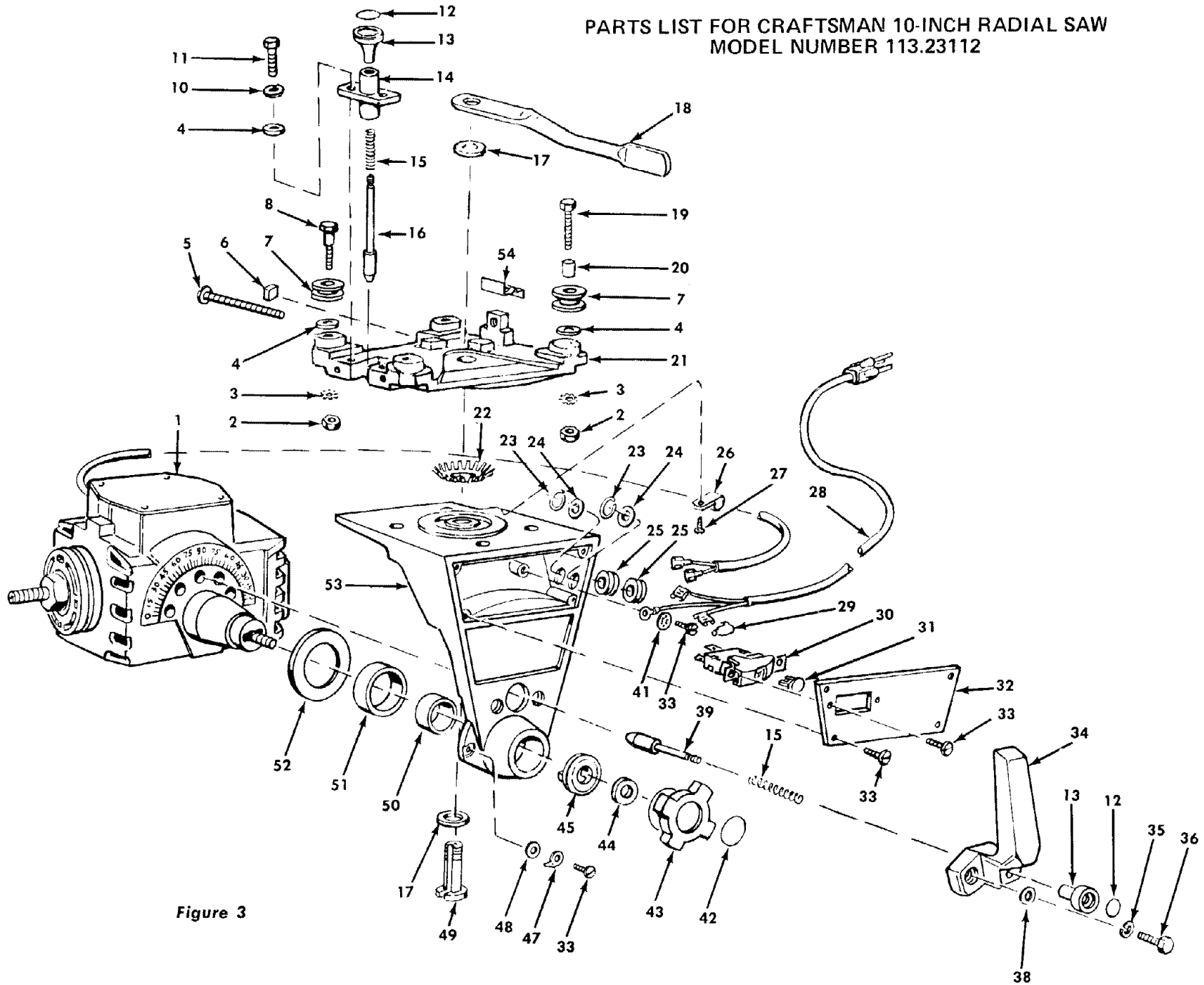

Figure 3

**PARTS LIST FOR CRAFTSMAN 10-INCH RADIAL SAW
MODEL NUMBER 113.23112**

FIGURE 3

Key No.	Part No.	Description
1	63507	Motor (See Figure 4)
2	STD 541231	*Nut, Hex 5/16-18 x 1/2 x 3/16
3	114605	*Lockwasher, External Tooth, 5/16
4	60040	Washer
5	60052	*Screw, Mach.Fil.Hd.,10-32 x 1-1/2
6	63527	Bumper, Carriage
7	63350	Bearing, Carriage
8	37387	Screw, Eccentric
10	STD 551131	*Lockwasher, 5/16
11	STD 523110	*Screw, Mach.Hex Hd., 5/16-18 x 1
12	63513	Disc, Color
13	63013	Knob, Swivel Index
14	63351	Housing, Latch Pin
15	63004	Spring, Swivel Latch
16	63530	Pin, Latch
17	60051	*Washer, .688 x 1-1/8 x 1/32
18	63532	Handle, Yoke Clamp
19	60259	Screw, Mach., Hex Washer Hd.
20	37388	Sleeve, Bearing
21	63526	Carriage
22	63028	Plate, Index
23	60289	Ring, Clamp
24	60055	Washer, Fibre, .380 x 3/4 x 1/16
25	63045	Grommet
26	30613	Clamp, Cord
27	STD 600803	*Screw, Type 23, Pan,8-32 x 3/8

Key No.	Part No.	Description
28	63534	Cord with Plug
29	63467	Cap, Flag Terminal
30	60267	Switch, Locking
31	60256	Key, Switch
32	63515	Plate, Switch Mounting
33	STD 600602	*Screw, Type 23, Pan, 6-32 x 1/4
34	63003	Handle
35	STD 551137	Lockwasher, 3/8
36	STD 523710	Screw, Hex Hd., 3/8-16 x 1
38	60031	*Washer, .440 x 11/16 x 1/32
39	63005	Pin, Latch
41	STD 551206	*Lockwasher, Int.Tooth No.6
42	63514	Disc, Color
43	62331	Knob, Swivel Clamp
44	63011	Washer, Knob Clamp
45	63010	Washer, Clamp
47	63323	Indicator
48	37935	Washer, Fibre, .140 x .250 x 1/32
49	63531	Stud, Yoke Clamp
50	63006	Bushing, Yoke
51	63007	Bushing, Yoke No. 2
52	63009	Washer, Motor Clamp
53	63044	Yoke
54	63528	Shoe, Rip Lock

*Standard Hardware Item — May be Purchased Locally

PARTS LIST FOR CRAFTSMAN 10-INCH RADIAL SAW
MODEL NUMBER 113.23112

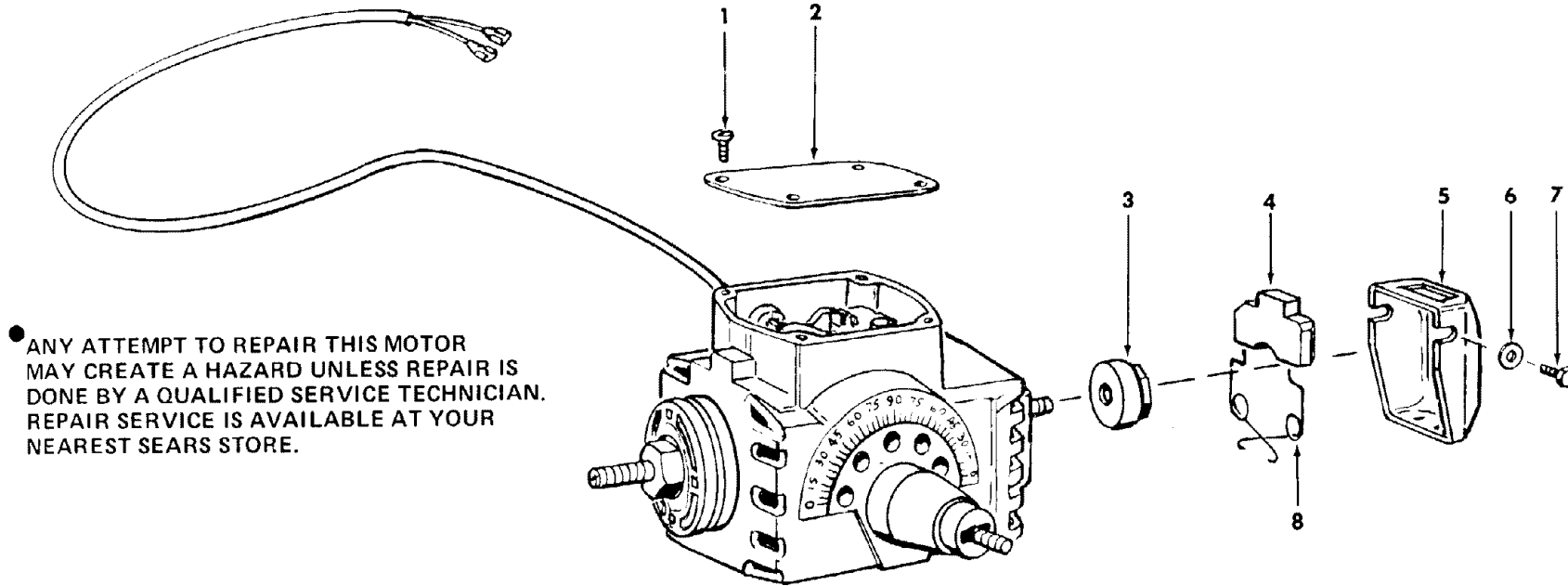

● ANY ATTEMPT TO REPAIR THIS MOTOR
MAY CREATE A HAZARD UNLESS REPAIR IS
DONE BY A QUALIFIED SERVICE TECHNICIAN.
REPAIR SERVICE IS AVAILABLE AT YOUR
NEAREST SEARS STORE.

FIGURE 4 – 63605 MOTOR ASSEMBLY

Key No.	Part No.	Description
—	63605	● Complete Motor Assembly
1	STD 600602	*Screw, Type 23, Pan Hd., No. 6-32 x 1/4
2	63771	Cover and Nameplate
3	65000	Drum, Brake
4	65002	Shoe, Brake
5	65003	Housing, Brake
6	60089	Washer, 17/64 x 1/2 x 1/32
7	STD 522503	*Screw, Mach., Hex Hd. 1/4-20 x 1/2
8	65001	Spring, Brake

- *Standard Hardware Item – May be Purchased Locally
- Any attempt to Repair This Motor May Create a **HAZARD**
Unless Repair is Done by a Qualified Service Technician.
Repair Service is Available at Your Nearest Sears Store

PARTS LIST FOR CRAFTSMAN 10-INCH RADIAL SAW
MODEL NUMBER 113.23112

FIGURE 5 – GUARD ASSEMBLY

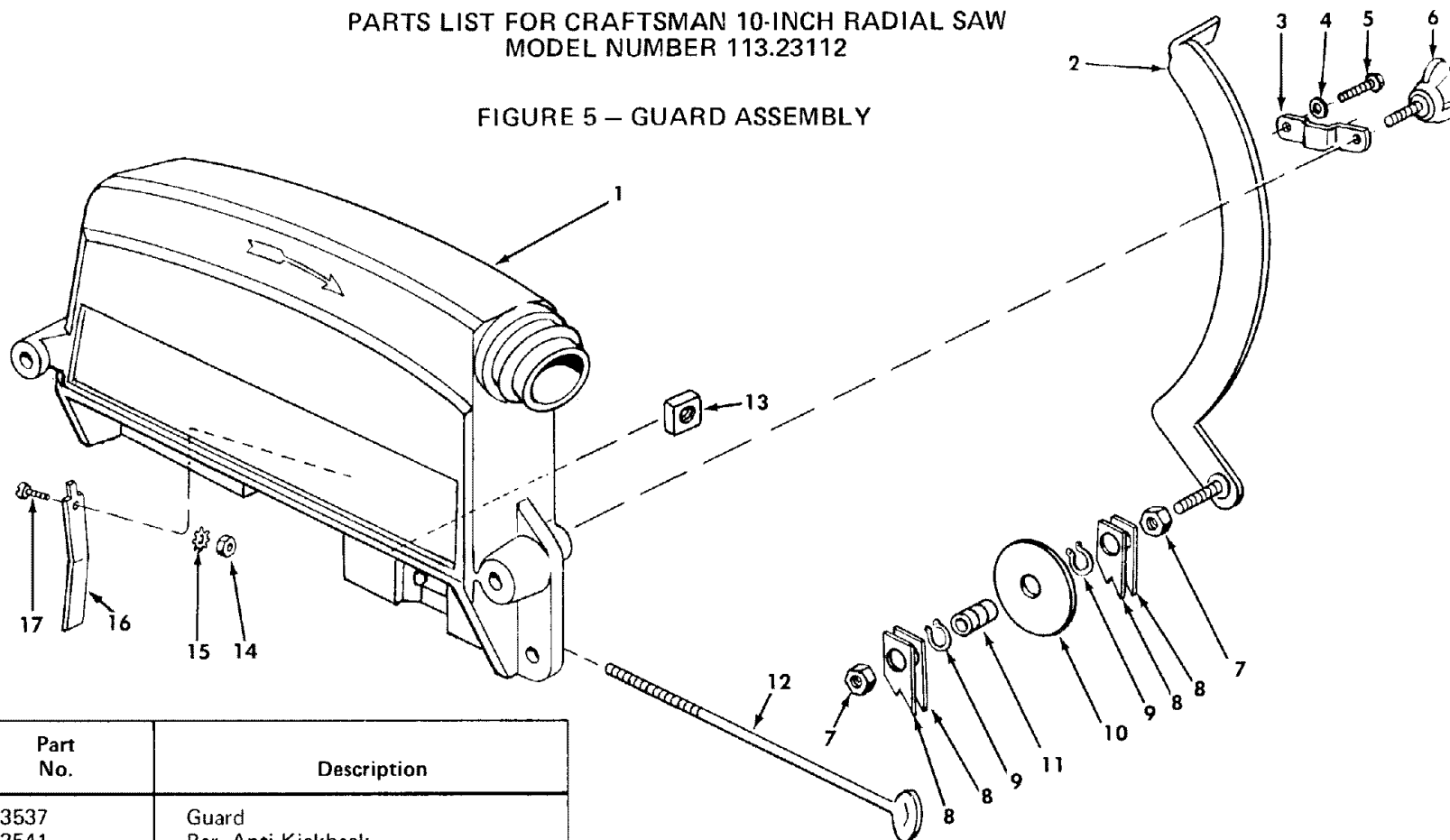

Key No.	Part No.	Description
1	63537	Guard
2	63541	Bar, Anti-Kickback
3	63540	Guide, Anti-Kickback
4	60136	*Washer, 13/64 x 5/8 x 1/32
5	STD 601103	*Screw, Type T Pan Hd., 10-32 x 3/8
6	60219	Screw, Wing
7	STD 541231	*Nut, Hex., 5/16-18
8	63271	Pawl, Anti-Kickback
9	60220	Ring, Retaining
10	63270	Spreader
11	63269	Bearing
12	63539	Screw, Guard Clamp
13	120399	*Nut, Square, 5/16-18 x 9/16 x 7/32
14	STD 541008	*Nut, Hex., 8-32
15	STD 551108	*Lockwasher, External Tooth No. 8
16	63538	Clamp, Guard
17	STD 510807	*Screw, Mach., Pan Hd., 8-32 x 1/2

*Standard Hardware Item – May be Purchased Locally.

Sears

*owners
manual*

SERVICE

**MODEL NO.
113.23112**

**HOW TO ORDER
REPAIR PARTS**

10-INCH RADIAL SAW

Now that you have purchased your 10-inch radial saw, should a need ever exist for repair parts or service, simply contact any Sears Service Center and most Sears, Roebuck and Co. stores. Be sure to provide all pertinent facts when you call or visit.

The model number of your 10-inch radial saw will be found on a plate attached to your saw, at the rear left-hand side of the base.

WHEN ORDERING REPAIR PARTS, ALWAYS GIVE THE FOLLOWING INFORMATION:

PART NUMBER	PART DESCRIPTION
MODEL NUMBER 113.23112	NAME OF ITEM 10-INCH RADIAL SAW

All parts listed may be ordered from any Sears Service Center and most Sears stores. If the parts you need are not stocked locally, your order will be electronically transmitted to a Sears Repair Parts Distribution Center for handling.

Sold by SEARS, ROEBUCK AND CO., Chicago, IL. 60684 U.S.A.