

COOKTOP

OPERATING SINGLE BURNERS

1. Push the desired gas surface control knob in and turn counterclockwise out of the OFF position -Fig. 1.
2. Release knob and rotate to (lite) position . Visually check that the needed burner has lit.
3. To adjust, push the knob in and turn counterclockwise to a flame size setting that best fits your need.

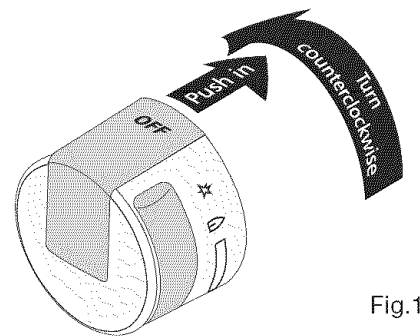
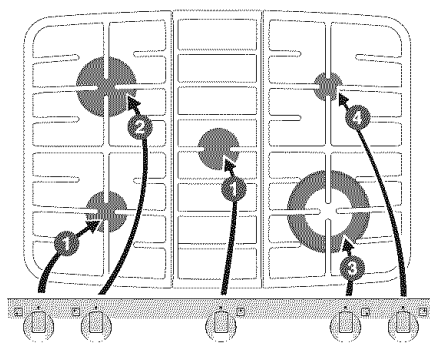

Fig.1

GAS BURNER LOCATIONS



- 1 Standard burner -9,500 BTU-best for most surface cooking requirements.
- 2 Large burner -14,000 BTU- best for bringing large quantities of liquid to boil or when preparing large quantities of food.
- 3 Min-2-Max™ burner -18,000 BTU- Capabilities of large burner combined with a simmer burner.
- 4 Perfect Simmer™ -5,000 BTU- best for simmering delicate sauces, melting chocolates, etc.

OPERATING MIN-2-MAX™ BURNER

1. Push the right front surface control knob in and turn counterclockwise out of the OFF position -Fig. 1.
 2. Release the knob and rotate to the (lite) position.
- Note: Although all electronic surface igniters will spark at the same time, only the selected surface burner will lite.
3. Visually check that both the inner and outer rings have lit -Fig. 4.

When both burners are lit, continue to turn the control knob counterclockwise to adjust to the desired flame size.

4. If only the inner burner is needed, continue to rotate the gas control knob counterclockwise past grey area as shown in Fig. 2.
5. Adjust the inner flame to desired size -Fig. 3.

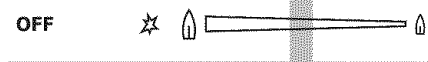

Fig. 2

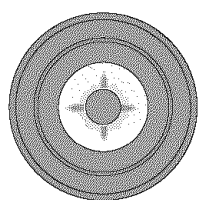

Fig. 3

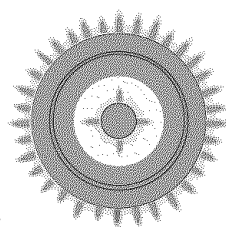

Fig. 4

LUXURY-GLIDE™ OVEN RACKS

REMOVING GLIDE RACKS

CAUTION

Always use potholders or oven mitts when removing food or adjusting the oven racks. Wait until the oven has completely cooled if possible. Oven racks may be **HOT** and may cause burns.

Use thumbs to press in on both left and right spring-loaded release levers - Fig. 1-. Place the remainder of both hands over the upper front of the glide rack. While pressing in on both levers, pull the rack straight out **slightly** and release thumb levers. Using both hands grasp **both the upper and lower portions** of the glide rack (-Fig. 1); pull rack using both hands straight out until reaching the stop position -Fig 2-. At the stop, lift up front of rack slightly and continue to pull rack away from oven -Fig 3-. Be sure to hold on both upper and lower rack portions when removing from or handling rack outside of the oven - these rack portions move independently and are difficult to handle unless held together

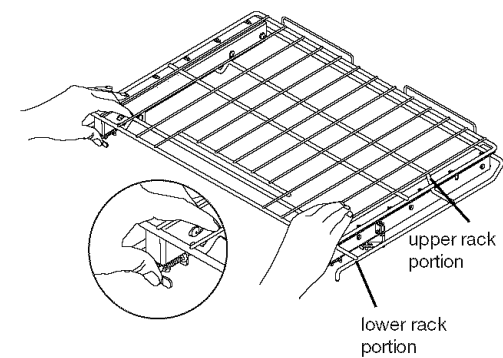

Fig. 1

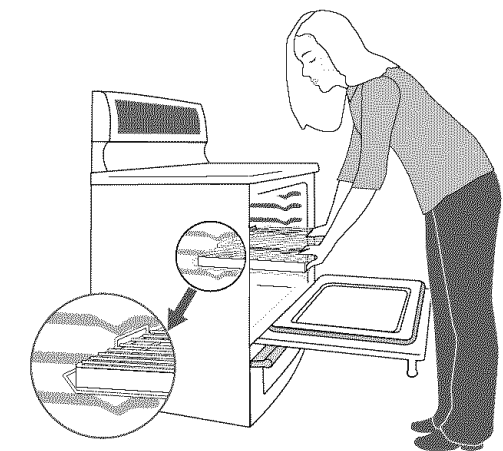

Fig. 2

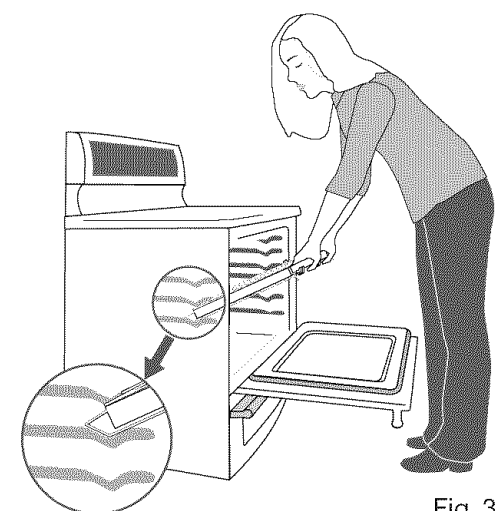
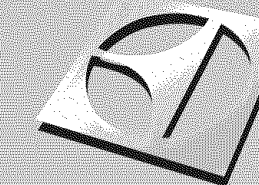

Fig. 3

REPLACING GLIDE RACKS

Grasp **both upper and lower portions** of glide rack, lift and place the rack resting evenly between the oven cavity walls. Tilt the front of the rack upward slightly and slide the rack completely into position. Some force may be necessary to make sure the oven rack has snapped completely back into place.



Quick Reference

30" Free-Standing Dual Fuel Range

Thank you for choosing Electrolux, the new premium brand in home appliances. We have provided you with this guide so that you may begin using your appliance right away.

SETTING CLOCK AT POWER UP

You will be prompted to enter the time of day in the event of a power failure or when you first provide power to your appliance.

- When your appliance is first powered up, 12:00 will flash in the display.
- Enter the time of day using the numeric key pads and press **START** to set.

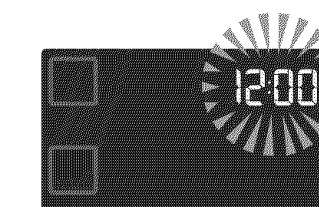

If an invalid time of day is entered, the control will triple beep. Re-enter a valid time of day and press **START**. If **CANCEL** is pressed your clock will start with a time of 12:00.

WAVE TOUCH™ DISPLAY MODES

SLEEP MODE

Your Wave Touch™ control will remain in a sleep mode when not in use. Only the clock will display during this mode. You will need to wake the control to begin an oven feature. The cooktop is available in sleep or awake mode.



AWAKE MODE

To wake the control touch within the display panel in the general area shown. After 2 minutes without activity, go back into sleep mode. To start cooking you must select either the upper oven or lower oven. User preferences will be available during this mode as well as timers, oven light and the control lock.

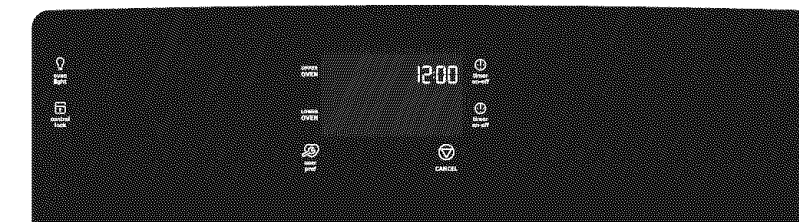

COOKING FEATURES

OVEN OPERATING TEMPERATURES

Feature	Default	Maximum	Minimum
Bake-upper	350°F/176°C	550°F/288°C	170°F/76°C
Bake-lower	350°F/176°C	450°F/232°C	170°F/76°C
Bread proof	HI 100°F/38°C	HI 100°F/38°C	LO 85°F/30°C
Broil	550°F/288°C	550°F/288°C	300°F/148°C
Conv bake	350°F/176°C	550°F/288°C	170°F/76°C
Conv broil	550°F/288°C	550°F/288°C	300°F/148°C
Conv roast	350°F/176°C	550°F/288°C	170°F/76°C
Defrost	80°F/26°C	NA	NA
Dehydrate	120°F/48°C	225°F/108°C	100°F/38°C
Keep warm	170°F/76°C	190°F/88°C	150°F/66°C
Probe	170°F/76°C	210°F/98°C	180°F/82°C

CONTROL LOCK

Step	Press
1	Choose CONTROL LOCK and hold for 3 seconds

To unlock, press and hold CONTROL LOCK again for 3 seconds.

Control lock will lock oven controls and upper oven door.

DOOR LOCK will flash in the display until the door has finished locking. Once the door has been locked, the door lock indicator will turn on. LOC will then display in the upper cavity only. Do not attempt to open the oven door while DOOR LOCK is flashing.

TIMERS

Step	Press
The two timers serve as extra reminders in the kitchen.	

To set the timer:

- Choose desired timer.
- Enter desired time and press START.

To cancel, press the timer key.

OVEN LIGHT

Step	Press
1	Press OVEN LIGHT to turn on lights manually

The oven lights will automatically turn on when the upper oven door is opened.

ABBREVIATIONS

Code	Explanation	Oven
Cln	Self clean	x
CLO	Setting the clock	x
dEF	Defrost	x
End	End of cycle	x
F10*	Fault code error	x
Hi	Hi setting	x
Hot	Hot oven	x
Lo	Lo setting	x
Loc	Control lock	x
Sab	Sabbath mode	x
Sd	Demo mode	x
Sf	Sabbath mode failure	
CF	Check food	

* F10 is an example of a fault code that you may see. These codes will help your servicer repair your appliance.

This guide is not intended to replace your user's manual. Refer to the Use & Care Guide for complete instructions.

COOKING FEATURES

BAKE

Step	Press
1	Press UPPER OVEN or LOWER OVEN
2	Press BAKE*
3	Press START

BROIL

Step	Press
1	Place the boiler insert on the broiler pan, then place food on the insert. Remember to follow all warnings and cautions.
2	Place prepared food directly under broil element. Leave oven door open slightly (about 4 inches).
3	Press UPPER OVEN
4	Press BROIL*
5	Press START

CONV BAKE

Step	Press
1	Press UPPER OVEN
2	Press CONV BAKE*
3	Press START

CONV BROIL

Step	Press
1	Place boiler insert on broiler pan, then place the food on insert. Remember to follow all warnings and cautions.
2	Place prepared food directly under broil element. Close oven door.
3	Press UPPER OVEN
4	Press CONV BROIL*
5	Press START

CONV ROAST

Step	Press
1	Press UPPER OVEN
2	Press CONV ROAST*
3	Press START

KEEP WARM

Step	Press
1	Press UPPER OVEN or LOWER OVEN
2	Press KEEP WARM*
3	Press START

SLOW COOK

Step	Press
1	Press UPPER OVEN or LOWER OVEN
2	Press SLOW COOK
3	Press -lo to choose the low option. Press +hi to choose the high option.
4	Press START

PERFECT TURKEY™

Step	Press
1	Insert the probe into the food and place food on rack in oven.
2	Plug the probe completely into the probe receptacle inside the oven.
3	Press UPPER OVEN
4	Press PERFECT TURKEY*
5	Press START

*Enter your desired temperature at this point if you choose not to use the default temp.

DEFROST

Step	Press
1	Press UPPER OVEN
2	Press DEFROST
3	Press START

DEHYDRATE

Step	Press
1	Press UPPER OVEN
2	Press DEHYDRATE*
3	Press START

BREAD PROOF

Step	Press
1	Press UPPER OVEN
2	Press BREAD PROOF <i>Use the + hi or - lo keys to change default temperature.</i>
3	Press START

MY FAVORITE (to save)

Step	Press
1	Press UPPER OVEN
2	Choose cooking feature & any additional options.
3	Press START
4	Press & hold available MY FAVORITE for 3 seconds.
5	Press CANCEL

*Enter your desired temperature at this point if you choose not to use the default temp.

MULTI STAGE

Step	Press
1	Press UPPER OVEN
2	Press MULTI STAGE

Stage 1

3	Choose 1st cooking feature
4	Enter temperature
5	Press START
6	Enter cooking time
7	Press START

Stage 2

8	Choose 2nd cooking feature
9	Enter temperature
10	Press START
11	Enter cooking time
12	Press START

Stage 3

13	Choose 3rd cooking feature
14	Enter temperature
15	Press START
16	Enter cooking time
17	Press START twice

SELF CLEAN

Step	Press
1	Press UPPER OVEN
2	Press CLEAN
3	Choose LITE, MED or HEAVY
4	Press START

COOKING OPTIONS

PROBE

Step	Press
1	Insert the probe into food and place in the oven.
2	Plug the probe completely into the probe receptacle inside the oven.
3	Choose UPPER OVEN
4	Choose cooking feature
5	Press COOK OPTIONS
6	Press PROBE
7	Press START

Cook options may be added to cooking features to make your cooking experience easier. The following options are available:

- Cook time
- End time
- Probe
- Rapid preheat
- Convection convert

COOK TIME

Step	Press
1	Choose UPPER OVEN or LOWER OVEN
2	Choose cooking feature
3	Press START
4	Press COOK OPTIONS
5	Press COOK TIME
6	Enter amount of cooking time
7	Press START

COOK TIME WITH END TIME

Step	Press
1	Choose UPPER OVEN or LOWER OVEN
2	Choose cooking feature
3	Press COOK OPTIONS
4	Press COOK TIME
5	Enter amount of cooking time
6	Press END TIME
7	Enter time of day you wish to stop cooking (00:00 format)
8	Press START

RAPID PREHEAT

Step	Press
1	Choose UPPER OVEN
2	Choose cooking feature
3	Press COOK OPTIONS
4	Press RAPID PREHEAT
5	Press START

CONVECTION CONVERT

Step	Press
1	Choose UPPER OVEN
2	Choose cooking feature
3	Press COOK OPTIONS
4	Press CONV CONVERT
5	Press START

USER PREFERENCES

The user preferences key will allow you to customize the way your appliance operates. User pref is only accessible when you are not cooking or using the timers. You will find options such as setting the clock, audio mode and other changes under the user preferences.