

42" and 46" Lawn Tractors

---

# Operating Manual

---

Model Nos. TMO-3310001  
TMO-3410002  
TMO-3510003

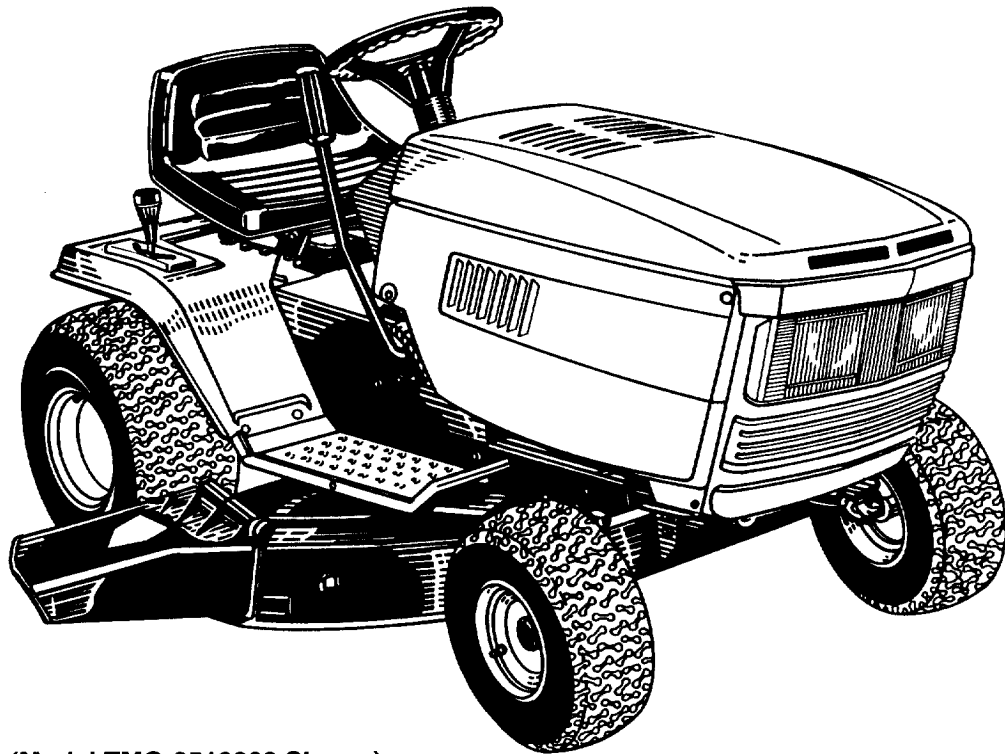

(Model TMO-3510003 Shown)

---

**WARNING:** This unit is equipped with an internal combustion engine and should not be used on or near any unimproved forest-covered, brush-covered or grass-covered land unless the engine's exhaust system is equipped with a spark arrester meeting applicable local or state laws (if any). If a spark arrester is used, it should be maintained in effective working order by the operator.

In the State of California the above is required by law (Section 4442 of the California Public Resources Code). Other states may have similar laws. Federal laws apply on federal lands. A spark arrester for the muffler is available through your nearest engine authorized service dealer or contact the service department, P.O. Box 368022, Cleveland, Ohio 44136-9722.

# IMPORTANT

## SAFE OPERATION PRACTICES





THIS SYMBOL POINTS OUT IMPORTANT SAFETY INSTRUCTIONS WHICH, IF NOT FOLLOWED, COULD ENDANGER THE PERSONAL SAFETY AND/OR PROPERTY OF YOURSELF AND OTHERS. READ AND FOLLOW ALL INSTRUCTIONS IN THIS MANUAL BEFORE ATTEMPTING TO OPERATE YOUR UNIT. WHEN YOU SEE THIS SYMBOL—  **HEED ITS WARNING.**



### DANGER:



Your lawn mower was built to be operated according to the rules for safe operation in this manual. As with any type of power equipment, carelessness or error on the part of the operator can result in injury. This lawn mower is capable of amputating hands and feet and throwing objects. Failure to observe the following safety instructions could result in serious injury or death.

-  **I. GENERAL OPERATION**
1. Read, understand, and follow all instructions in the manual and on the machine before starting. Keep this manual in a safe place for future and regular reference and for ordering replacement parts.
  2. Only allow responsible individuals familiar with the instructions to operate the machine. Know controls and how to stop the machine quickly.
  3. Do not put hands or feet under cutting deck or near rotating parts.
  4. Clear the area of objects such as rocks, toys, wire, etc., which could be picked up and thrown by the blade. A small object may have been overlooked and could be accidentally thrown by the mower in any direction and cause injury to you or a bystander. To help avoid a thrown objects injury, keep children, bystanders and helpers at least 75 feet from the mower while it is in operation. Always wear safety glasses or safety goggles during operation or while performing an adjustment or repair, to protect eyes from foreign objects. Stop the blade(s) when crossing gravel drives, walks or roads.
  5. Be sure the area is clear of other people before moving. Stop machine if anyone enters the area.
  6. Never carry passengers.
  7. Disengage blade(s) before shifting into reverse and backing up. Always look down and behind before and while backing.
  8. Be aware of the mower and attachment discharge direction and do not point it at anyone. Do not operate the mower without either the entire grass catcher or the chute guard in place.
  9. Slow down before turning. Operate the machine smoothly. Avoid erratic operation and excessive speed.
  10. Never leave a running machine unattended. Always turn off blade(s), place transmission in neutral, set park brake, stop engine and remove key before dismounting.
  11. Turn off blade(s) when not mowing.
  12. Stop engine and wait until blade(s) comes to a complete stop before (a) removing grass catcher or unclogging chute, or (b) making any repairs, adjusting or removing any grass or debris.
  13. Mow only in daylight or good artificial light.
  14. Do not operate the machine while under the influence of alcohol or drugs.
  15. Watch for traffic when operating near or crossing roadways.
  16. Use extra care when loading or unloading the machine into a trailer or truck. This unit should not be driven up or down a ramp onto a trailer or truck under power, because the unit could tip over, causing serious personal injury. The unit must be pushed manually on a ramp to load or unload properly.
  17. Never make a cutting height adjustment while engine is running if operator must dismount to do so.
  18. Wear sturdy, rough-soled work shoes and close-fitting slacks and shirts. Do not wear loose fitting clothes or jewelry. They can be caught in moving parts. Never operate a unit in bare feet, sandals, or sneakers.
  19. Check overhead clearance carefully before driving under power lines, wires, bridges or low hanging tree branches, before entering or leaving buildings, or in any other situation where the operator may be struck or pulled from the unit, which could result in serious injury.
  20. Disengage all attachment clutches, thoroughly depress the brake pedal, and shift into neutral before attempting to start engine.
  21. Your mower is designed to cut normal residential grass of a height no more than 10". Do not attempt to mow through unusually tall, dry grass (e.g., pasture) or piles of dry leaves. Debris may build up on the mower deck or contact the engine exhaust presenting a potential fire hazard.
-  **II. SLOPE OPERATION**
- Slopes are a major factor related to loss of control and tip-over accidents which can result in severe injury or death. **All** slopes require extra caution. If you cannot back up the slope or if you feel uneasy on it, do not mow it.
- For your safety, use the slope gauge included as part of this manual to measure slopes before operating this unit on a sloped or hilly area. If the slope is greater than 15° as shown on the slope gauge, do not operate this unit on that area or serious injury could result.
- DO:**
- Mow up and down slopes, not across.
  - Remove obstacles such as rocks, limbs, etc.
  - Watch for holes, ruts or bumps. Uneven terrain could overturn the machine. **Tall grass can hide obstacles.**
  - Use slow speed. Choose a low enough gear so that you will not have to stop or shift while on the slope. Always keep machine in gear when going down slopes to take advantage of engine braking action.
  - Follow the manufacturer's recommendations for wheel weights or counterweights to improve stability.
  - Use extra care with grass catchers or other attachments. These can change the stability of the machine.
  - Keep all movement on the slopes **slow** and **gradual**. Do not make sudden changes in speed or direction. Rapid engagement or braking could cause the front of the machine to lift and rapidly flip over backwards which could cause serious injury.
  - Avoid starting or stopping on a slope. If tires lose traction, disengage the blade(s) and proceed slowly **straight** down the slope.
- DO NOT:**
- Do not** turn on slopes unless necessary; then, turn slowly and gradually downhill, if possible.
  - Do not** mow near drop-offs, ditches or embankments. The mower could suddenly turn over if a wheel is over the edge of a cliff or ditch, or if an edge caves in.
  - Do not** mow on wet grass. Reduced traction could cause sliding.
  - Do not** try to stabilize the machine by putting your foot on the ground.
  - Do not** use grass catcher on steep slopes.
-  **III. CHILDREN**
- Tragic accidents can occur if the operator is not alert to the presence of children. Children are often attracted to the machine and the mowing activity. **Never** assume that children will remain where you last saw them.

1. Keep children out of the mowing area and in watchful care of an adult other than the operator.
2. Be alert and turn machine off if children enter the area.
3. Before and when backing, look behind and **down** for small children.
4. Never carry children. They may fall off and be seriously injured or interfere with the safe machine operation.
5. Never allow children under 14 years old to operate the machine. Children 14 years and over should only operate machine under close parental supervision and proper instruction.
6. Use extra care when approaching blind corners, shrubs, trees or other objects that may obscure your vision of a child or other hazard.
7. Remove key when machine is unattended to prevent unauthorized operation.

#### IV. SERVICE

1. Use extreme care in handling gasoline and other fuels. They are extremely flammable and the vapors are explosive.
  - a. Use only an approved container.
  - b. Never remove fuel cap or add fuel with the engine running. Allow engine to cool at least two minutes before refueling.
  - c. Replace fuel cap securely and wipe off any spilled fuel before starting the engine as it may cause a fire or explosion.
  - d. Extinguish all cigarettes, cigars, pipes and other sources of ignition.
  - e. Never refuel the machine indoors because fuel vapors will accumulate in the area.
  - f. Never store the fuel container or machine inside where there is an open flame or spark, such as a gas hot water heater, space heater or furnace.
2. Never run a machine inside a closed area.
3. To reduce fire hazard, keep the machine free of grass, leaves or other debris build-up. Clean up oil or fuel spillage. Allow machine to cool at least 5 minutes before storing.
4. Before cleaning, repairing or inspecting, make certain the blade and all moving parts have stopped. Disconnect the spark plug wire, and keep the wire away from the spark plug to prevent accidental starting.
5. Check the blade and engine mounting bolts at frequent intervals for proper tightness. Also, visually inspect blade for damage (e.g., excessive wear, bent, cracked). Replace with blade which meets original equipment specifications.
6. Keep all nuts, bolts and screws tight to be sure the equipment is in safe working condition.
7. Never tamper with safety devices. Check their proper operation regularly. Use all guards as instructed in this manual.
8. After striking a foreign object, stop the engine, remove the wire from the spark plug and thoroughly inspect the mower for any damage. Repair the damage before restarting and operating the mower.
9. Grass catcher components are subject to wear, damage and deterioration, which could expose moving parts or allow objects to be thrown. For your safety protection, frequently check components and replace with manufacturer's recommended parts when necessary.
10. Mower blades are sharp and can cut. Wrap the blade(s) or wear gloves and use extra caution when servicing blade(s).
11. Check brake operation frequently. Adjust and service as required.
12. Muffler, engine and belt guards become hot during operation and can cause a burn. Allow to cool down before touching.
13. Do not change the engine governor settings or overspeed the engine. Excessive engine speeds are dangerous.
14. Observe proper disposal laws and regulations. Improper disposal of fluids and materials can harm the environment and the ecology.
  - a. Prior to disposal, determine the proper method to dispose of waste from your local Environmental Protection Agency. Recycling centers are established to properly dispose of materials in an environmentally safe fashion.
  - b. Use proper containers when draining fluids. Do not use food or beverage containers that may mislead someone into drinking from them. Properly dispose of the containers immediately following the draining of fluids.
  - c. DO NOT pour oil or other fluids into the ground, down a drain or into a stream, pond, lake or other body of water. Observe Environmental Protection Agency regulations when disposing of oil, fuel, coolant, brake fluid, filters, batteries, tires and other harmful waste.

<p><b>OWNER'S MANUAL</b></p> 	<p><b>SAFETY LABEL</b></p> 	<p> <b>WARNING — YOUR RESPONSIBILITY</b></p> <p>Restrict the use of this power machine to persons who read, understand and follow the warnings and instructions in this manual and on the machine.</p>
--	--	---

## UNPACKING

### TO REMOVE UNIT FROM CRATE

1. Remove all screws from the top of the crate using a 1/4" hex head socket or a flat blade screwdriver.
2. To remove ends, grasp top board on the end, and pull towards you in a downward motion.
3. Set panel aside to avoid tire punctures.
4. Repeat procedure for each side of the crate.
5. Remove and discard plastic bag which covers unit.
6. Loose parts (may include the owner's guide, steering wheel, battery fluid, chute deflector, optional mulching kit, etc.) are on the seat and wrapped in plastic. Carefully cut and remove the plastic wrap. Remove loose parts from the seat.
7. Make certain brake is released. Raise the deck. Use the relief valve and push the unit off the skid.

# ASSEMBLY INSTRUCTIONS

## BATTERY INFORMATION



### WARNING

- A. Battery acid must be handled with great care as contact with it can burn and blister the skin. It is also advisable to wear protective clothing (goggles, rubber gloves and apron) when working with it.
- B. Should battery acid accidentally splatter into the eyes or onto the face, rinse the affected area immediately with clean cold water. If there is any further discomfort, seek prompt medical attention.
- C. If acid spills on clothing, first dilute it with clean water, then neutralize with a solution of ammonia/water or baking soda/water.
- D. Since battery acid is corrosive, do not pour it into any sink or drain. Before discarding empty electrolyte containers, rinse them with a neutralizing solution.
- E. NEVER connect or disconnect charger clips to battery while charger is turned on as it can cause sparks.
- F. Keep all lighted materials (cigarettes, matches, lighters) away from the battery as the hydrogen gas generated during charging can be combustible.
- G. As a further precaution, only charge the battery in a well-ventilated area.

**\*Always shield eyes, protect skin and clothing when working near batteries.**



### DANGER

**Battery contains sulfuric acid. Refer to warning above.** Antidote: EXTERNAL—Flush with water. INTERNAL—Drink large quantities of water or milk. Follow with milk of magnesia, beaten eggs or vegetable oil. Call physician immediately. **IF YES:** Flush with cool water for at least 15 minutes, then get prompt medical attention.

**Since batteries produce explosive gases, keep all lighted materials (cigarettes, lighters, matches, etc.) away.** Be sure to charge battery only in well-ventilated areas. Make certain venting path of battery (drain tube) is always open.

**KEEP BATTERIES  
OUT OF THE REACH OF CHILDREN!**

**IMPORTANT:** After assembly, service engine with gasoline, and check oil level as instructed in the separate engine manual packed with your unit.

**NOTE:** Reference to right or left hand side of the unit is observed from the driver's seat, facing forward.

## TOOLS REQUIRED FOR ASSEMBLY

- (1) 1/4" socket wrench or flat blade screwdriver
- (1) 1/2" wrench or socket wrench
- (1) 9/16" wrench or socket wrench
- (2) 7/16" wrenches or socket wrenches

## ACTIVATING AND CHARGING THE BATTERY

**Do not activate battery (fill with battery acid) until battery is actually placed in service. Be certain to read previous warnings before activating the battery.**

1. Pivot the seat forward. Unhook the strap which secures the battery (hook is on rear frame, under fender). Disconnect the positive cable from the positive terminal. Save the hardware for reassembly.
2. Remove the battery from the lawn tractor, paying attention to how the battery is placed in the unit, and how the drain tube (attached to the battery) is routed.
3. Activate the battery as instructed in the "Quick Start" brochure included with the battery fluid.  
**Read instructions carefully.**

**NOTE:** You can continue assembling the lawn tractor while battery is standing for 30 minutes (after filling with acid), and later while you are charging the battery.

**IMPORTANT:** To obtain the maximum life from your battery, it **MUST BE CHARGED** prior to initial use.

**CHARGE THE BATTERY** after the 30 minute standing period. Use a 12-volt automotive type battery charger to charge the battery at 6 AMPS for one hour before installation.

**NOTE:** If you charge the battery at a lower AMP rate, use a hydrometer to make sure the battery is completely charged. The hydrometer should read 1.260 minimum. **DO NOT CHARGE AT MORE THAN 6 AMPS.**

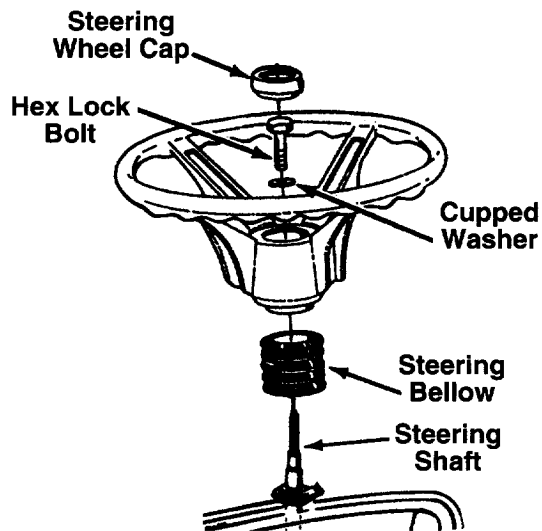

FIGURE 1.

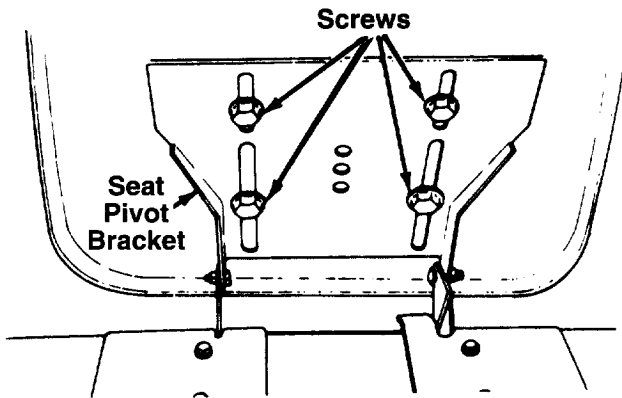

FIGURE 2.

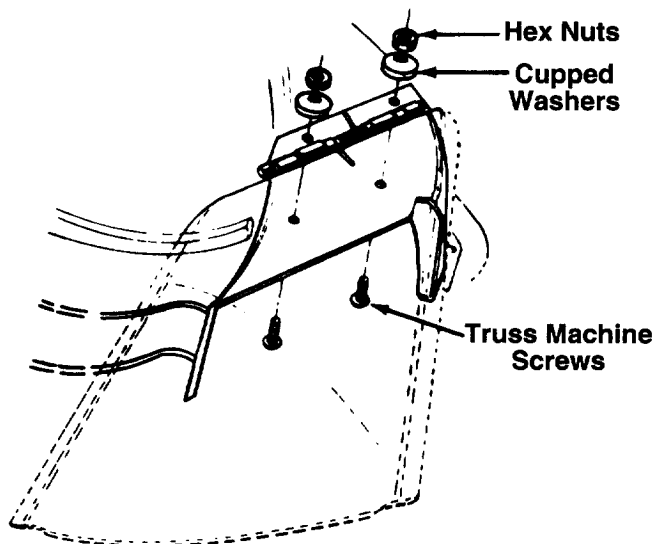

FIGURE 3.

### ATTACHING THE STEERING WHEEL

1. The hardware for attaching the steering wheel has been packed inside the steering wheel. Carefully pry off the steering wheel cap and remove the hardware.
2. Remove the steering bellow from the lift lever on the right hand side of lawn tractor. Place steering bellow over the steering shaft extending through the dash. ←

**NOTE:** If the openings on each end of the steering bellow are two different sizes, the smaller end goes down against the dash of the lawn tractor.

3. **With the wheels of the tractor pointing straight forward**, place the steering wheel over the steering shaft, positioning steering wheel as desired.
4. Place the washer with the cupped side down over the steering shaft. Secure with hex lock bolt.
5. Place the steering wheel cap over the center of the steering wheel and seat it with your hand.

### ATTACHING THE SEAT

- Remove the four screws which secure the seat to the seat pivot bracket. Turn the seat around and place in position against the seat pivot bracket, lining up the slotted holes in the pivot bracket with the holes in the seat. Select desired position for the seat, and secure with the four screws. See figure 2. ←

### ATTACHING THE CHUTE DEFLECTOR

The chute deflector must be attached to the right side of the deck so that it covers the chute opening.



**WARNING:** Do not operate your unit unless the chute deflector has been properly installed.

1. Make certain deck is raised to its highest position (lift lever pulled all the way back).
2. Remove the truss machine screws, cupped washers and hex jam nuts which are attached to the deck next to the chute opening.
3. Place the chute deflector in position as shown in figure 3. Secure with hardware just removed. Cupped sides of washers go against the chute ←

### TIRE PRESSURE

The tires on your unit may be over-inflated for shipping purposes. Reduce the tire pressure before operating the unit. Recommended operating tire pressure is approximately 12 p.s.i.



**WARNING:** Maximum tire pressure under any circumstances is 30 p.s.i. Equal tire pressure should be maintained on all tires.

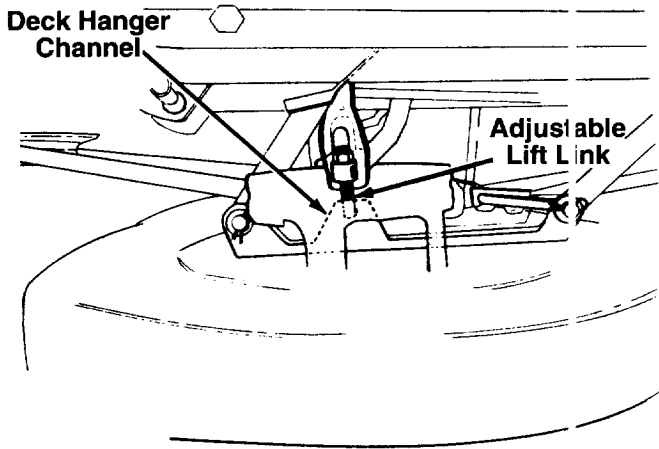

FIGURE 4.

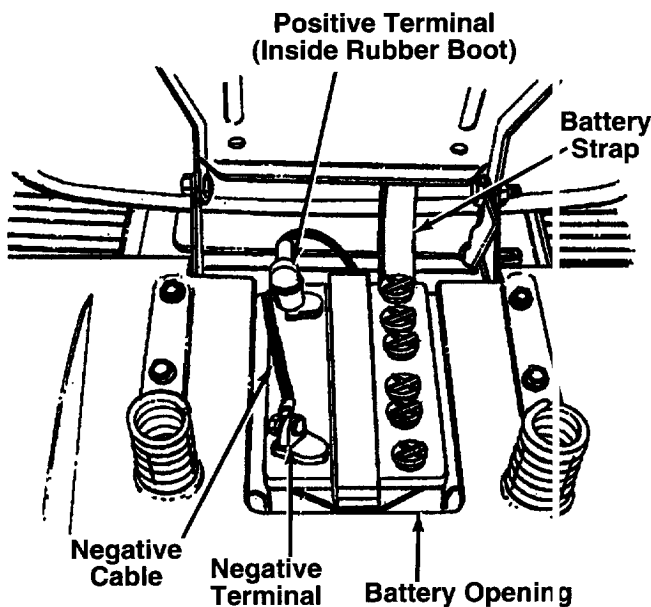

FIGURE 5.

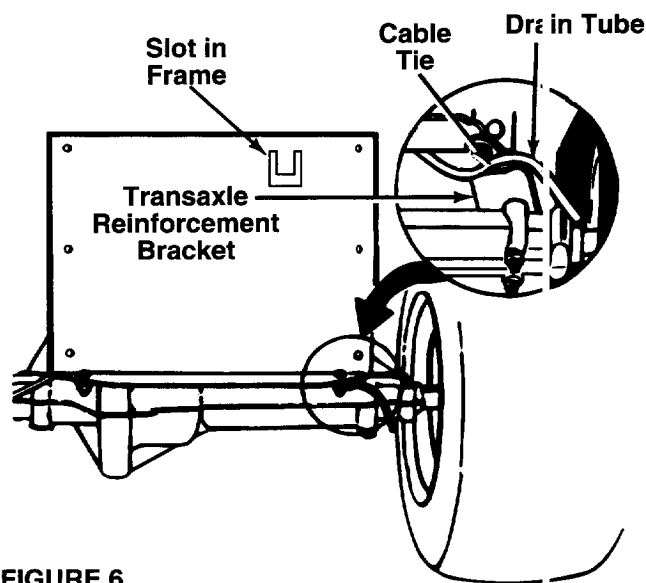

FIGURE 6.

## LEVELING THE DECK

With unit on hard, level surface, measure the distance from the bottom edge of the center of the left side of deck to the ground. Measure the same distance on the center of the right side of the deck, just behind the chute area. Or, place the blades in a straight line, and measure the distance from the outside edge of the blade tips to the ground.

If adjustment is needed, proceed as follows.

- ← 1. Remove the hairpin clip and flat washer from the bottom of the adjustable lift link on the left side of the deck. (Hairpin clip and flat washer are on the inside of the lift link.)
2. Pull the adjustable lift link out of the deck hanger channel. See figure 4. Turn the adjustable lift link up or down as necessary to level the deck. Usually only one or two turns are needed.
3. Insert the end of the adjustable lift link into the hole in the deck hanger channel. Recheck the adjustment. Readjust if necessary.
4. When deck is level, secure end of adjustable lift link with flat washer and hairpin clip.

## INSTALLING THE BATTERY

1. Lift the seat.
2. Make certain both the negative (black) cable and the positive (red) cable are routed up through the battery opening as shown in figure 5.
- ← 3. Replace the battery into the battery opening in the same position as it was before (positive terminal is toward the front of the unit).
4. Attach the positive (red) cable to the positive terminal of the battery. Secure with hex bolt and nut previously removed. Slide rubber boot down over the positive terminal.
5. Remove the hex bolt and nut from the negative (black) cable. Attach negative cable to the negative terminal with this bolt and nut.
6. Secure battery by hooking battery strap into slot in rear frame, under the fender. See figure 6.
7. Insert the drain tube through the hole in the transaxle bracket or through the cable tie (if so equipped) which is attached to the transaxle reinforcement bracket on the **right** side of the unit.
- ← See figure 6. Be certain drain tube is routed away from the wheel rim.
8. Pull cable tie (if so equipped) to secure the drain tube, but do not overtighten or the tube could collapse. Trim excess end of cable tie.
9. Trim excess end of drain tube if necessary (about 4" should extend past the bracket or cable tie).

# CONTROLS

## IGNITION SWITCH

The ignition switch is located on the dashboard. The engine is started by turning the key to the START position. When the engine is running, leave the key in the ON position. To stop the engine, turn the key to the OFF position. See figure 7.



**WARNING:** Remove the key from the tractor when the tractor is not in use to prevent accidental starting.

## THROTTLE CONTROL

The throttle control is located on the dashboard and is used to regulate the engine speed. To get maximum efficiency from cutting, the throttle should be in the FAST position when operating the mower. See figure 7.

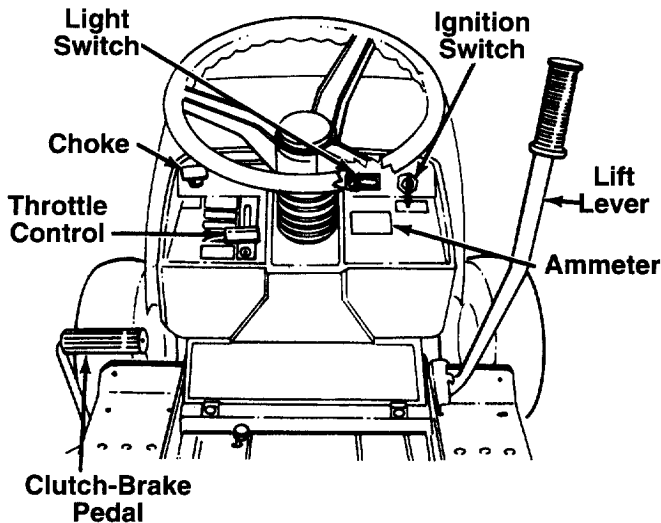

FIGURE 7.

## CHOKE CONTROL

The choke control is located on the dashboard and is operated manually. Details for the choke operation are covered in the separate engine manual packed with your unit. See figure 7.

## LIGHT SWITCH

The head lamps are operated by pushing the light switch located on the dashboard. The head lamps will only operate when the engine is running. See figure 7.

## AMMETER

The ammeter registers the rate of battery charge or discharge. The ammeter will register on the discharging side with starting the engine. It should register on the opposite side (charging) when the engine is running in the fast position until the battery is completely charged. With a fully charged battery or with the engine idling, the ammeter will not show a charge. See figure 7.

## HYDROSTATIC CONTROL LEVER

The hydrostatic control lever is located on top of the fender on the right side of the tractor. This single control lever, connected to the hydrostatic transmission, controls both the speed and direction of the tractor. Infinite speed control is achieved by moving the control lever forward or backward. The farther forward or backward you move the control lever, the faster you will travel. Pulling the control lever into neutral (N) area will stop the tractor. See figure 8.

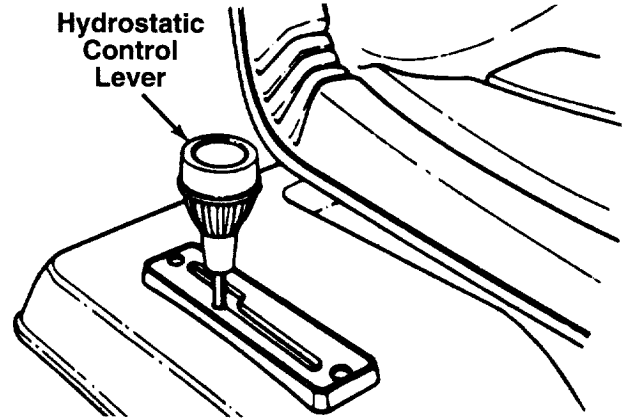

FIGURE 8.

## CLUTCH-BRAKE PEDAL

The clutch-brake pedal is located on the left side of the tractor. See figure 7. Depressing the pedal returns the drive unit to neutral (N) and applies the brake.

**NOTE:** The clutch-brake pedal must be depressed to start the engine.

## PARKING BRAKE

To set the parking brake, depress the clutch-brake pedal, pull up the parking brake knob and release the clutch-brake pedal. It will stay in the raised position. To release the parking brake, depress and release the clutch-brake pedal. See figure 9.

**NOTE:** The parking brake must be set if the operator leaves the seat with the engine running.

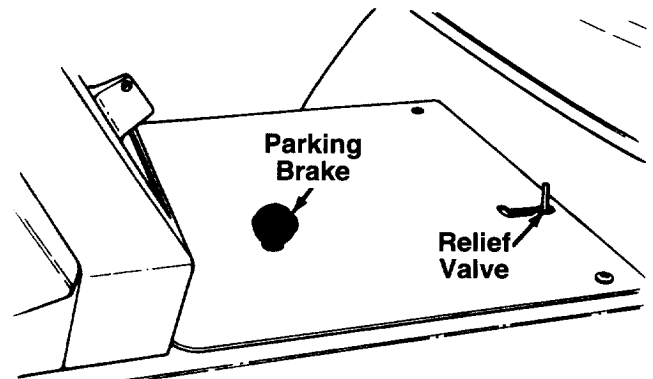

FIGURE 9.

## RELIEF VALVE

A hydrostatic relief valve is provided so the unit can be moved without the engine running. The lever which operates the relief valve is located on the console. See figure 9.

To operate the relief valve, place the hydrostatic control lever in neutral, release the parking brake, push the lever forward and to the right to lock. Be certain to release the lever by pushing it to the left before operating the engine.

## CUTTING CONTROLS

### A. LIFT LEVER

The lift lever is used to raise and lower the cutting deck and to engage and disengage the blades. Pulling it all the way back and locking it disengages the blades.

**NOTE:** The lift lever **must** be in the **BLADES OFF** position when starting the engine, when shifting into reverse and if the operator leaves the seat. See figure 10.

### B. DECK LIFT INDICATOR

The deck lift indicator marks the position being used for the lift lever. Select the lift lever position desired, press the indicator lever outward, move it to the position immediately below the lift lever and release the indicator lever. See figure 10.

### C. SETTING THE CUTTING HEIGHT

1. Select the position for the lift lever which gives the desired cutting height. Move the deck lift indicator so that the lift lever can be returned to the same position after it is raised.
2. Move the deck wheels to the hole location so the wheels are 1/4 to 1/2 inch above the ground.

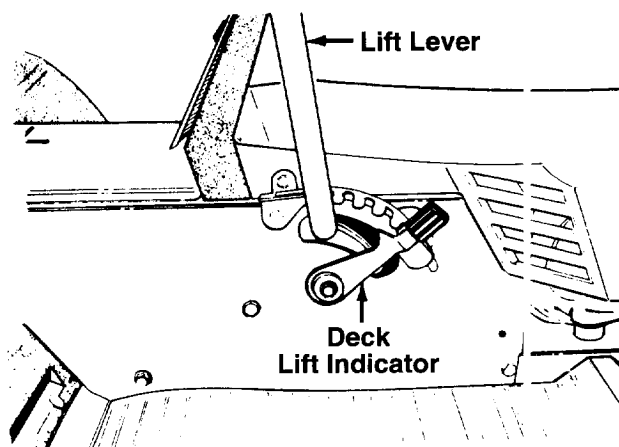

FIGURE 10.

## OPERATION



### WARNING

#### AVOID SERIOUS INJURY OR DEATH

- GO UP AND DOWN SLOPES, NOT ACROSS. • AVOID SUDDEN TURNS.
- DO NOT OPERATE THE UNIT WHERE IT COULD SLIP OR TIP.
- IF MACHINE STOPS GOING UPHILL, STOP BLADE(S) AND BACK DOWNHILL SLOWLY.
- DO NOT MOW WHEN CHILDREN OR OTHERS ARE AROUND.
- NEVER CARRY CHILDREN.
- LOOK DOWN AND BEHIND BEFORE AND WHILE BACKING.
- KEEP SAFETY DEVICES (GUARDS, SHIELDS, AND SWITCHES) IN PLACE AND WORKING.
- REMOVE OBJECTS THAT COULD BE THROWN BY THE BLADE(S).
- KNOW LOCATION AND FUNCTION OF ALL CONTROLS.
- BE SURE BLADE(S) AND ENGINE ARE STOPPED BEFORE PLACING HANDS OR FEET NEAR BLADE(S).
- BEFORE LEAVING OPERATOR'S POSITION, DISENGAGE BLADE(S), PLACE THE SHIFT LEVER IN NEUTRAL, ENGAGE BRAKE LOCK, SHUT ENGINE OFF AND REMOVE KEY.

READ OPERATOR'S MANUAL

## GAS AND OIL FILL-UP

**Check the oil level and add if necessary. Service the engine with gasoline as instructed in the separate engine manual packed with your tractor. Read instructions carefully.**

**IMPORTANT:** Your tractor is shipped with oil; however you **must** check the oil level before operating. Be careful not to overfill.



**WARNING:** Never fill fuel tank indoors, with engine running or while engine is hot.

## STARTING THE ENGINE

**IMPORTANT:** This unit is equipped with a **safety interlock system** for your protection. The purpose of the safety interlock system is to prevent the engine from cranking or starting unless the clutch-brake pedal is depressed and the lift lever is in the **BLADES OFF** position. In addition, the lift lever must be in the **BLADES OFF** position when the unit is put into reverse or the engine will shut off. If the operator leaves the seat with the lift lever engaged and/or without setting the parking brake, the engine will shut off.



**WARNING:** Do not operate the tractor if the interlock system is malfunctioning because it is a safety device, designed for protection.



1. Place the lift lever in the BLADES OFF position.
2. Depress the clutch-brake pedal and set the parking brake.
3. Place the hydrostatic control lever in the NEUTRAL (N) position.
4. Set the throttle control in the FAST position.
5. Pull out the choke control (a warm engine may not require choking).
6. Turn the ignition key to the right to the START position. After the engine starts, release the key. It will return to the ON position.

**NOTE:** Protect the starter life by using short starting cycles of several seconds. Cranking more than 15 seconds per minute can damage the starter motor.

7. Push choke knob in gradually. Move the throttle control to desired engine speed.

### STOPPING THE ENGINE

Turn the ignition key to the left to the OFF position. Remove the key to prevent accidental starting.

**IMPORTANT:** If you strike a foreign object, stop the engine. Remove wire from spark plug, thoroughly inspect the unit for any damage, and repair the damage before restarting and operating the mower.

**NOTE:** If any problems are encountered, refer to the Trouble Shooting Guide on page 16.

### OPERATING THE LAWN TRACTOR

1. Set the desired cutting height.
2. Move throttle control to full throttle to prevent strain on the engine and to operate the cutting blades.
3. Depress the clutch-brake pedal so the parking brake is released, and then release the clutch-brake pedal.
4. Place the hydrostatic control lever in either the FORWARD or REVERSE position. The farther forward you move the hydrostatic control lever, the faster you will travel.



**WARNING:** Look to the rear before backing up.

To stop the lawn tractor, pull the hydrostatic control lever into NEUTRAL (N) or depress the clutch-brake pedal.

Be sure that the lawn is clear of stones, sticks, wire, or other objects which could damage lawn tractor or engine. For best results and to insure more even grass distribution, do not mow when lawn is excessively wet.



**WARNING:** Before leaving the operator's position for any reason, disengage the blades, place the hydrostatic control lever in neutral, engage the parking brake, shut engine off and remove the key.

When stopping the unit to empty a grass bag, etc., follow the instructions above. This procedure will also eliminate "browning" the grass, which is caused by hot exhaust gases from a running engine.

### GRASS COLLECTOR AVAILABLE

Grass Collector OEM-190-063 is available as optional equipment for lawn tractors with 42" decks. Grass Collector OEM-190-103 is available for lawn tractors with 46" decks.



**WARNING:** The mower should not be operated without the entire grass catcher or chute deflector in place.

**NOTE:** Under normal usage bag material is subject to wear, and should be checked periodically. Be sure to use only factory authorized replacement bag.

---

## ADJUSTMENTS

---



**WARNING:** Disconnect the spark plug wires and ground against the engine before performing any adjustments, repairs or maintenance.

### SEAT ADJUSTMENT

To adjust the position of the seat, loosen the four screws on the bottom of the seat. See figure 2. Slide the seat forward or backward as desired. Retighten the four screws.

### HYDROSTATIC NEUTRAL CONTROL ADJUSTMENT

The hydrostatic transmission control is in correct adjustment when the tractor does not move with the engine running, the clutch engaged and the hydrostatic control lever in the neutral position.

If adjustment is necessary, follow these steps:

1. Raise both rear wheels off the ground by placing blocks under the rear frame.
2. Remove the transmission panel by removing the parking brake knob and truss machine screws.
3. Loosen the hex jam nut on the speed selector adjusting rod. See figure 11.

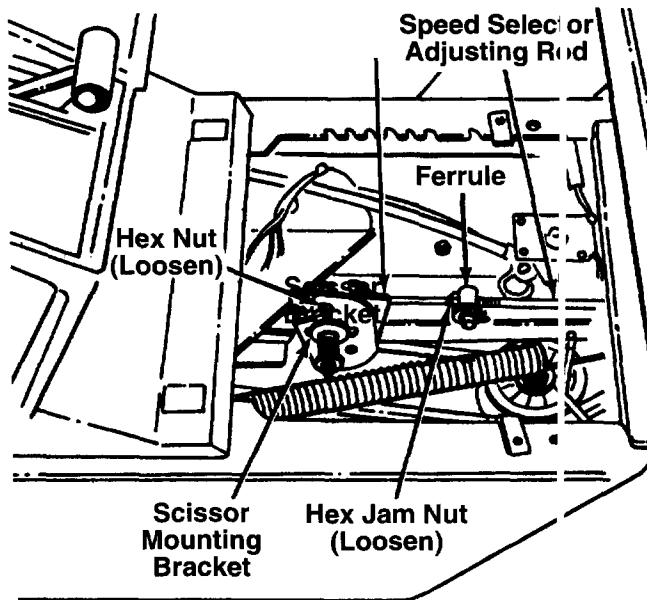

**FIGURE 11.**

4. Loosen the hex nut on the scissor mounting bracket. See figure 11.
5. Start the engine and run at full throttle.
6. Move the hydrostatic control lever until you find neutral (rear wheels do not rotate in either direction).



**WARNING: Be careful of the cooling fan on the hydrostatic transmission.**

7. Depress the clutch-brake pedal until the scissor brackets come together.
8. Shut off the engine.
9. Tighten the hex nut on the scissor mounting bracket.
10. Thread the speed selector rod in or out of the ferrule until the hydrostatic control lever lines up in the neutral position on the speed control index bracket.
11. Tighten hex jam nut against the ferrule.
12. Replace the transmission panel and parking brake knob.
13. Remove the blocks from under the frame and test the operation of the tractor.

### DECK LEVELING ADJUSTMENT

If an uneven cut is obtained, the deck may be leveled by following instructions in Assembly section.

### CUTTING DECK ENGAGEMENT ADJUSTMENT

The cutting deck engagement may be adjusted to make certain deck is disengaged when lift lever is in the BLADES OFF position, or to obtain more drive in the cutting positions. Correct adjustment as follows.

With the engine off, place the lift lever in the highest cutting position (first position). Remove the cotter pin and flat washer which secure the disengagement rod to the stabilizer shaft assembly. See figure 12. Shorten the rod by threading it in until the ferrule is against the back of the slot in the lift shaft assembly, and the rod lines up with the hole in the stabilizer shaft. For more belt tension the disengagement rod must be lengthened. To decrease belt tension the disengagement rod must be shortened.

Check the adjustment by placing the lift lever in the BLADES OFF position. The deck should move up and forward, allowing the belt to become loose. Start and test for disengagement. Repeat procedure as necessary.

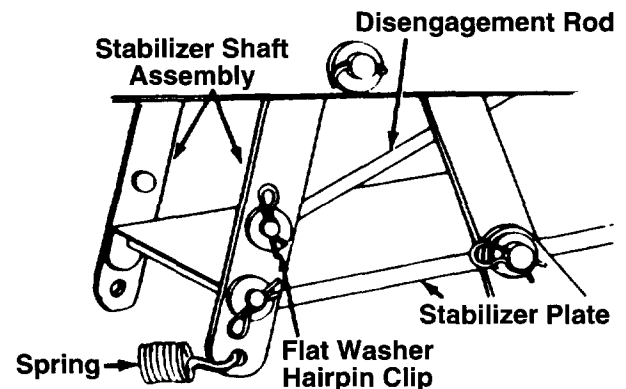

**FIGURE 12.**

### BRAKE ADJUSTMENT (See figure 14)

The brake is located by the right rear wheel inside the frame. The brake has been set at the factory to the proper clearance. During normal operation of this machine, the brakes are subject to wear and will require periodic examination and adjustment.



**WARNING: Do not have the engine running when you adjust the brake.**

To check for proper setting, place a feeler gauge between two of the discs. There should be from 0.015 to 0.025 inch clearance. See figure 13.

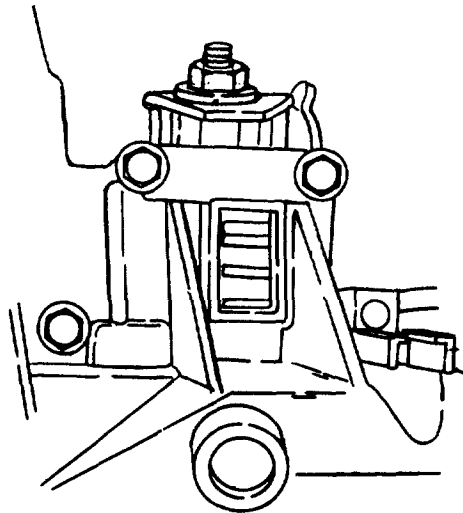

**FIGURE 13.—Bottom View**

If the clearance is not correct, make the necessary change with adjustment nut. See figure 14.

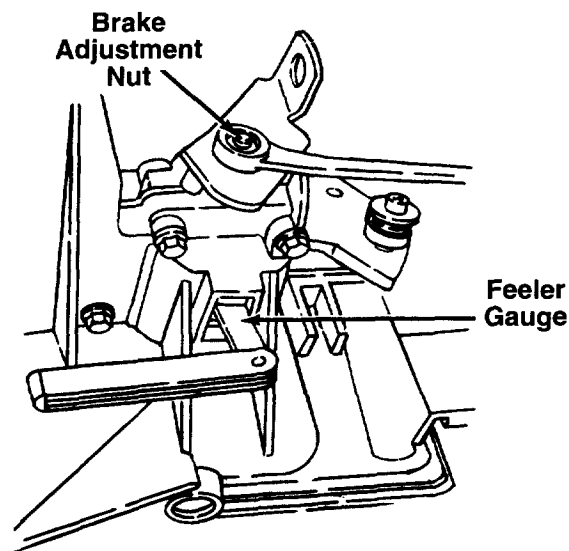

**FIGURE 14.**

### CARBURETOR ADJUSTMENTS



**WARNING:** If any adjustments are made to the engine while the engine is running (e.g. carburetor), disengage all clutches and blades. Keep clear of all moving parts. Be careful of heated surfaces and muffler.

Minor carburetor adjustments may be required to compensate for differences in fuel, temperature, altitude and load. Refer to separate engine manual for carburetor adjustment information.

**NOTE:** A dirty air cleaner will cause an engine to run rough. Be certain air cleaner is clean and attached to the carburetor before adjusting carburetor.

## LUBRICATION



**WARNING:** Always stop engine and disconnect spark plug wire before cleaning, lubricating or doing any kind of work on lawn tractor.

### STEERING GEARS

Lubricate teeth of steering gears with automotive multi-purpose grease after every 25 hours of operation or once a season. See figure 15.

### STEERING SHAFT

Lubricate steering shaft at least once a season with light oil.

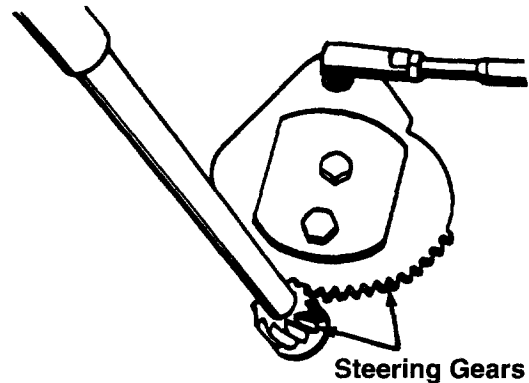

**FIGURE 15.**

### HYDROSTATIC TRANSMISSION

The hydrostatic transmission is filled at the factory and does not require checking. If repairs are needed, contact your local service dealer. (Hydrostatic transmission contains approximately 2.5 quarts of SAE 20W50 oil.)

### LINKAGE

Once a season lubricate all the pivot points on the clutch, brake and lift linkage with SAE 30 engine oil.

### WHEELS

The front wheels are provided with grease fittings. The rear wheels must be removed from the axle for lubrication. Lubricate at least once a season with automotive multi-purpose grease.

### PIVOT POINTS

Lubricate all pivot points with light oil at least once a season.

### BALL JOINTS

The ball joints and drag link ends are permanently lubricated.

## MAINTENANCE



**WARNING: Disconnect the spark plug wire and ground against the engine before performing any adjustments, repairs or maintenance.**

### TROUBLE SHOOTING

Refer to the chart on page 16 for troubleshooting engine problems.

### HYDROSTATIC TRANSMISSION COOLING

The hydrostatic transmission is cooled by the oil, fan and fins. If the hydrostatic transmission runs hot, check to see if the fan is in operating condition, the oil level is correct and the fins are clean.

**NOTE: DO NOT use high pressure water spray or steam to clean the hydrostatic transmission.**

### ENGINE

Refer to the separate engine manual for engine maintenance instructions.

Service **air cleaner** every 10 hours under normal conditions. Clean every few hours under extremely dusty conditions. To service the air cleaner, refer to the separate engine manual packed with your unit.

The **spark plugs** should be cleaned and the gap reset once a season. Spark plug replacement is recommended at the start of each mowing season; check engine manual for correct plug type and gap specifications.

Maintain **engine oil** as instructed in the separate engine manual packed with your unit. Read and follow instructions carefully.

### FUEL FILTER

Your unit is equipped with a replaceable in-line fuel filter. Replace filter whenever contamination or discoloration is noticed. Order replacement filter through your authorized engine service dealer.

### CLEANING ENGINE AND DECK

Any fuel or oil spilled on the machine should be wiped off promptly. Grass, leaves, and other dirt must not be left to accumulate around the cooling fins of the engine or on any part of the machine.

Clean the underside of the deck after each mowing.

### WHEEL ADJUSTMENT

The caster (forward slant of the king pin) and the camber (tilt of the wheels out at the top) require no adjustment. Automotive steering principles have been used to determine the caster and camber on the tractor. The front wheels should toe-in 1/8 inch.

To adjust the toe-in, follow these steps.

1. Remove the hex nut and lock washer, and drop the end of the tie rod from the axle bracket. See figure 16.
2. Loosen the hex jam nut on tie rod.
3. Adjust the tie rod assembly for correct toe-in.

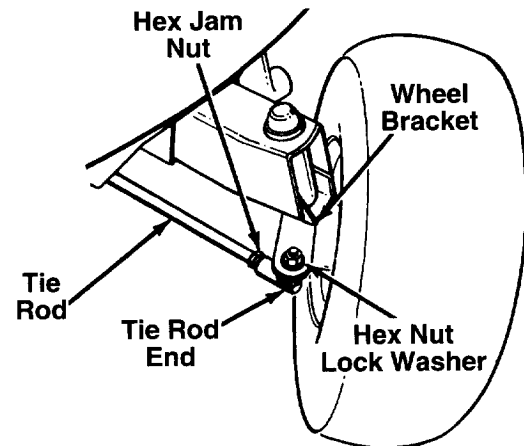

FIGURE 16.

Dimension "B" should be approximately 1/8" less than Dimension "A." See figure 17. To increase Dimension "B," screw tie rod into tie rod end. To decrease Dimension "B," unscrew tie rod from tie rod end. Reassemble tie rod. Check dimensions. Readjust if necessary.

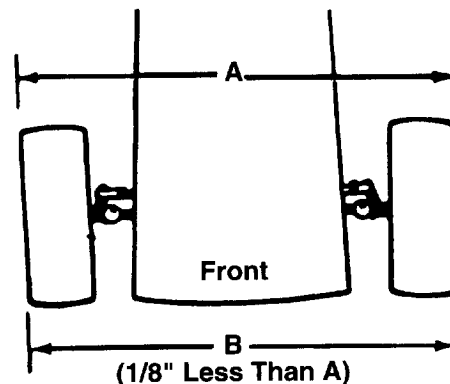

FIGURE 17.

### CUTTING BLADES

#### A. Removal for Sharpening or Replacement



**WARNING: Be sure to disconnect and ground the spark plug wire and remove ignition key before working on the cutting blade to prevent accidental engine starting. Protect hands by using heavy gloves or a rag to grasp the cutting blades.**

1. Remove the large bolt and lock washer which holds the blade and adapter to the blade spindle.
2. Remove the blade and adapter from the spindle.
3. If the blade or blade adapter needs replacing, remove the two small bolts, lock washers and nuts which hold the blade to the adapter (does not apply to all models).

### B. Sharpening

Remove the cutting blades by following the directions of the preceding section.

When sharpening the blades, follow the original angle of grind as a guide. It is extremely important that each cutting edge receives an equal amount of grinding to prevent an unbalanced blade. An unbalanced blade will cause excessive vibration when rotating at high speeds, may cause damage to the mower and could break, causing personal injury.

The blade can be tested for balance by balancing it on a round shaft screwdriver. Remove metal from the heavy side until it balances evenly.

**NOTE:** *It is recommended that the blade always be removed from the adapter for the best test of balance.*

### C. Reassembly

Before reassembling the blade and the blade adapter to the unit, lubricate the spindle and the inner surface of the blade adapter with light oil (or engine oil). Lubricating the bolt holes, bolts and inner surface of the nuts is also recommended.

When replacing blades, be sure to install the blade with the side of the blade marked "Bottom" (or with part number) facing the ground when the mower is in the operating position.

### Blade Mounting Torque

Center Bolt: 450 in. lb. min., 600 in. lb. max.

Blade Adapter Bolts (if applicable): 200 in. lb. min., 350 in. lb. max.

To ensure safe operation of your unit, **all** nuts and bolts must be checked periodically for correct tightness.

## BATTERY CARE AND MAINTENANCE

### CHECK FLUID LEVEL

Check fluid level inside each cell of the battery every two weeks and before and after charging. Always keep level just below the split rings.

**Add only distilled water. Never add additional acid or any other chemicals to the battery after initial activation.**

**NOTE:** *After operating the lawn tractor for a long period of time, check the fluid level in the battery as it can overheat and lose fluid.*

## CHARGING THE BATTERY

The engine is equipped with an alternator which charges battery when tractor is operated. Under normal conditions, the battery only needs to be charged before, during and after off-season storage. Follow the instructions under "Off-Season Storage."

**To charge the battery:** Make certain fluid level in each cell is just below the split rings. Use a 12 volt automotive charger which is rated at 6 amps. Charge the battery to 1.260 minimum specific gravity.

## REMOVING / INSTALLING / JUMP STARTING



**WARNING:** When removing or installing the battery, follow these instructions to prevent the screwdriver from shorting against the frame.

**Removing the Battery:** Disconnect negative cable first, then positive cable.

**Installing the Battery:** Connect positive cable first, then negative cable.

### Jump Starting

1. First, connect end of one jumper cable to the positive terminal of the good battery, then the other end to the positive terminal of the dead battery.
2. Connect the other jumper cable to the negative terminal of the good battery, then to the **FRAME OF THE UNIT WITH THE DEAD BATTERY.**



**WARNING:** Failure to use this procedure could cause sparking, and the gas in either battery could explode.

## CLEAN THE BATTERY

Clean the battery by removing it from the unit and washing with a baking soda and water solution. If necessary, scrape the battery terminals with a wire brush to remove deposits. Coat terminals and exposed wiring with grease or petroleum jelly to prevent corrosion.

## BATTERY FAILURES

Some common causes for battery failure are: incorrect initial activation, lack of water, adding chemicals other than water after initial activation, undercharging, overcharging, corroded connections, freezing. **These failures do not constitute warranty.**

## TIRES

Recommended operating tire pressure is approximately 12 p.s.i. Maximum tire pressure under any circumstances is 30 p.s.i. Equal tire pressure should be maintained on all tires.

When installing a tire to the rim, be certain rim is clean and free of rust. Lubricate both the tire and rim generously. Never inflate to over 30 p.s.i. to seat beads.



**WARNING:** Excessive pressure (over 30 p.s.i.) when seating beads may cause tire/rim assembly to burst with force sufficient to cause serious injury.

## BELT REMOVAL AND REPLACEMENT



**WARNING:** Disconnect the spark plug wire and ground it against the engine. Block the wheels of the unit.

**NOTE:** Figures 18 and 20 are shown with the unit tipped up for clarity. It is not necessary to tip the unit to remove the belts.

However, if tipping the unit is desired, remove the battery from the unit. To prevent gasoline leakage, drain the gasoline, or remove the fuel tank cap, place a thin piece of plastic over the neck of the fuel tank and screw on the cap. Be certain to remove the plastic when finished changing the belts. Block unit securely.

### DECK BELT

1. Place the lift lever in the BLADES OFF position.
2. Remove the belt keeper pins from the engine pulley belt guard. See figure 18.

**NOTE:** When reassembling, make certain belt keeper pins are assembled in the same locations from which they were removed. See figure 18.

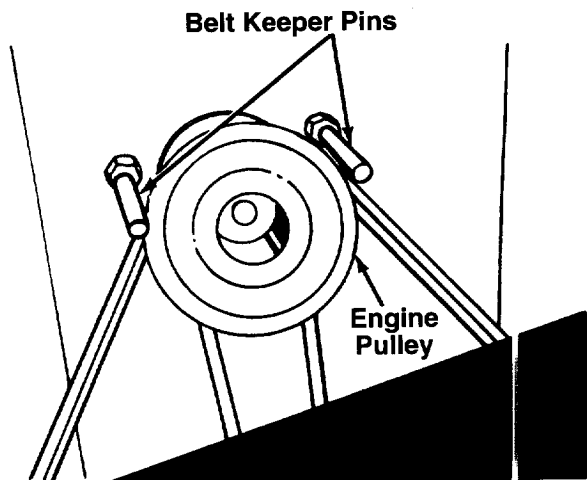

**FIGURE 18.**

3. Unhook the deck belt from the engine pulley.
4. Place the lift lever in the engaged (all the way forward) position.
5. Disconnect the spring which is attached to a bracket on the transaxle, inside the right rear wheel. Use a spring puller or other suitable tool.
6. Disconnect the six deck links by removing the hairpin clips and flat washers.

7. Disconnect the stabilizer plate from the stabilizer shaft assembly by removing the hairpin clips and flat washers and sliding out the rod. Refer to figure 12.
8. Place the lift lever in the BLADES OFF position.
9. Slide the deck from beneath the lawn tractor.
10. Remove the belt guards at each deck pulley by removing the self-tapping screws. See figure 19.

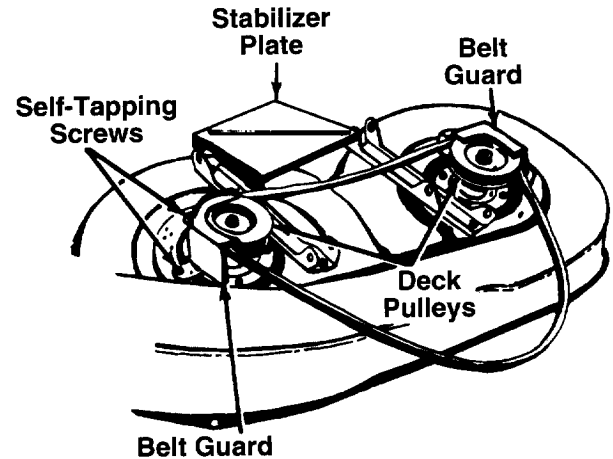

**FIGURE 19.**

11. Remove and replace the belt, reassemble following the instructions in reverse order.

### DRIVE BELT (See Figure 20)

1. Depress the clutch pedal and set the parking brake.
2. Remove the deck from the lawn tractor.
3. Raise and block the front wheels of the lawn tractor so you can work under it.
4. Remove the transmission panel by removing the parking brake knob and truss machine screws.
5. Raise the seat. Disconnect the battery cables. Remove the battery from the unit.
6. Disconnect the idler pulley spring which is attached to a bracket on the frame, inside the left rear wheel. Use a spring puller or other suitable tool.
7. Remove the three self-tapping screws from the cooling fan. Remove the fan.
8. Remove the center bolt, lock washer and flat washer, and let the engine pulley drop down so the belt is past the belt guards.
9. Roll the belt off of top sheave of engine pulley, onto the pulley hub.
10. Remove the belt from the transmission pulley and engine pulley, and remove from the unit.
11. Reassemble using a new belt, following instructions in reverse order.

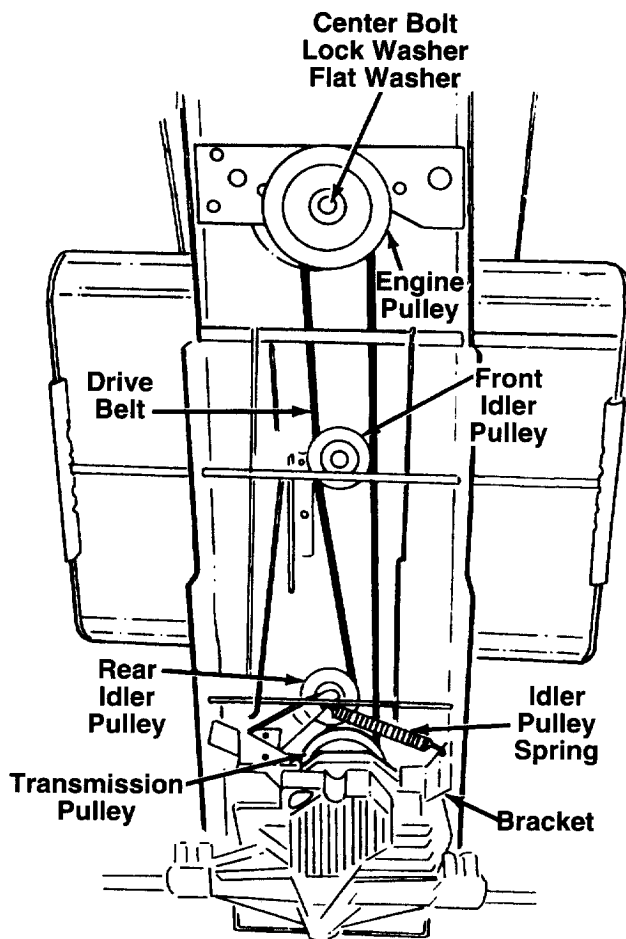

FIGURE 20.

## OFF-SEASON STORAGE

If the machine is to be inoperative for a period longer than 30 days, prepare for storage as follows.

1. Clean the engine and the entire unit thoroughly.
2. Lubricate all lubrication points. Wipe the entire machine with an oiled rag to protect the surfaces.
3. Refer to the engine manual for correct engine storage instructions. The engine must be completely drained of fuel to prevent gum deposits from forming on essential carburetor parts, fuel lines and fuel tanks.
4. **Charge battery fully.** The battery loses some of its charge each day when the unit is not used. NEVER store battery without a full charge. Recharge battery before returning to service or every two months, whichever occurs first.
5. When storing unit for extended periods, disconnect battery cables. Removing battery from unit is recommended.
6. Store unit in a clean, dry area. Do not store next to corrosive materials, such as fertilizer.

**NOTE:** When storing any type of power equipment in an unventilated or metal storage shed, care should be taken to rustproof the equipment. Using a light oil or silicone, coat the equipment, especially any chains, springs, bearings and cables.

## OPTIONAL EQUIPMENT

At the time of manufacture of lawn tractor, the following optional equipment is available.

**NOTE:** These lawn tractors are not designed for ground-engaging equipment (tillers, plows, etc.).

Description	Model No.
36" Single Stage Snow Thrower	OEM-190-491
42" Dozer Blade	OEM-190-485
Mulching Kit for 38" Deck	OEM-190-096
Mulching Kit for 42" Deck	OEM-190-097
Twin Bag Grass Collector for 42" Side Discharge Decks	OEM-190-063
Twin Bag Grass Collector for 46" Side Discharge Decks	OEM-190-103
Front Counterweight	190-745-000
Tire Chains—20 x 8	OEM-190-658
31 Lb. Wheel Weights	OEM-190-215
Gang Reel (Set of three)	45-0195*
38" Lawn Sweeper	45-0222*
Heavy Duty Lawn Roller	45-0179*
Heavy Duty Dump Cart	45-0171*
Tine De-Thatcher	45-0186*

\*Available through your local dealer or from Agri-Fab Inc., 303 W. Raymond Street, Sullivan, Illinois 61951.

# TROUBLE SHOOTING GUIDE

PROBLEM	POSSIBLE CAUSE(S)	CORRECTIVE ACTION
Engine will not crank.	Safety switch button not depressed	There are two switches in the starting circuit of your unit: the clutch pedal switch and the deck lift lever switch. Make certain the actuator is fully depressing the buttons on each switch.
	Battery installed incorrectly	The battery must be installed with negative terminal attached to black ground wire. Negative terminal is identified at the post by "NEG", "N" or "-". The positive terminal, identified by "POS", "P" or "+", must be attached to the big red wire which goes to the solenoid.
	Battery is dead or weak	Check fluid level in battery. If fluid is low, fill to just below the split rings with water. Charge with 6 amp charger until fully charged.
	Blown fuse or circuit breaker	Replace fuse with automotive type fuse. Fuses seldom fail without a reason. The problem must be corrected. Check for loose connections in the fuse holder. Replace fuse holder if necessary. A dead short may be in the cranking or charging circuit where the insulation may have rubbed through and exposed the bare wire. Replace the wire or repair with electrician's tape if the wire strands have not been damaged. Note: Look for a wire pinched between body panels, burned by the exhaust pipe or muffler or rubbed against a moving part.
	Engine ground wire loose	Engine should have a black ground wire running from engine to frame or mounting bolt.
Engine cranks but will not start	Throttle or choke not in starting position	Check owner's guide for correct position for throttle control and choke for starting.
	No spark to spark plug	Spark plug lead disconnected. Connect lead. Hold spark plug lead away from engine block about 1/8". Crank engine. There should be a spark. If not, have engine repaired at authorized engine service dealer.  Faulty spark plug. To test, remove spark plug. Attach spark plug lead to spark plug. Ground the spark plug body against the engine block. Crank the engine. The spark plug should fire at the electrode. Replace if it does not.
	No fuel to the carburetor	Gasoline tank empty. Fill.  Fuel line or in-line fuel filter plugged. Remove and clean fuel line. Replace filter if necessary.
	Air filter dirty	If the air cleaner is dirty, the engine may not start. Clean or replace as recommended by the engine manufacturer.
Engine smokes	Engine loses crankcase vacuum	Dipstick not seated or broken. Replace defective part. Engine breather defective. Replace.
Excessive vibration	Bent or damaged blade spindle	<b>Stop engine immediately.</b> Check all pulleys, blade adapters, keys and bolts for tightness and damage. Tighten or replace any damaged parts.
	Bent blade	<b>Stop engine immediately.</b> Replace damaged blade. Only use original equipment blades.
Mower will not discharge grass or leaves uncut strips	Engine speed low Speed selection Blades short or dull	Throttle must be set at full throttle. Use lower ground speed. The slower your ground speed, the better the quality of cut. Sharpen or replace blades (uncut strip problem only).

If the above steps fail to correct the problem, take the unit to your local authorized service dealer for repair.



The only way to ensure the performance of your product is to use original equipment parts and accessories. When you substitute, you take a chance on quality, reliability, safety and performance.

Throttle Control Wire 35" Lg.	746-0634
Battery (275 Cold Crank Amps)	725-1707
Front Hub Cap (Black)	731-0484A (2)
Front Wheel Bearings (Plastic)	741-0487A (4)
Fuse 7.5 AMP	725-1625
Fuse 20 AMP	725-1381
Head Lamp Bulbs	725-0963 (2)
Deck Wheel 5"	734-0973 (2)
Ignition Key	725-0201
Drive Belt	754-0441
DECK 42":	
Mulching Blades	742-0538(2)
High Lift Blades	742-0499A (2)
Blade Adapter	748-0300 (2)
V-Belt (Deck)	754-0371A
Grass Collector+	OEM-190-063
DECK 46":	
V-Belt (Deck)—Upper	754-0439
V-Belt (Deck)—Lower	754-0440
Outer Blades (2)	742-0542
Center Blade	742-0543
Grass Collector+	OEM-190-103
Illustrated Parts Lists	Order By Model No.

+ Optional



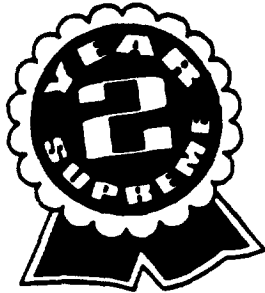

# MANUFACTURER'S LIMITED WARRANTY

For TWO YEARS from the date of retail purchase within the United States of America, its possessions and territories, MTD PRODUCTS INC will, at its option, repair or replace, for the original purchaser, free of charge, any part or parts found to be defective in material or workmanship. This warranty covers units which have been operated and maintained in accordance with the owner's instructions furnished with the unit, and which have not been subject to misuse, abuse, commercial use, neglect, accident, improper maintenance or alteration.

Normal wear parts or components thereof are subject to separate terms as noted below in the "No Fault Ninety Day Consumer Warranty" clause.

All normal wear part failures will be covered on this product for a period of 90 days regardless of cause. After 90 days, but within the two year period, normal wear parts failures will be covered ONLY IF caused by defects in material or workmanship of OTHER component parts. Normal wear parts are defined as batteries\*, belts, blades, blade adapters, grass bags, rider deck wheels, seats, snow thrower skid shoes, shave plates and tires.

**How to obtain service:** Warranty service is available, with proof of purchase, through your local authorized service dealer. To locate the dealer in your area, please check the yellow pages or contact the Customer Service Department of MTD PRODUCTS INC, P O Box 368022, Cleveland, Ohio 44136-9722. Phone 1-800-800-7310. The return of a complete unit will not be accepted by the factory unless prior written permission has been extended by the Customer Service Department of MTD PRODUCTS INC.

**Transportation charges:** Transportation charges for the movement of any power equipment unit or attachment are the responsibility of the purchaser.

Units exported out of the United States: MTD PRODUCTS INC does not extend any warranty for

products sold or exported outside of the United States of America, its possessions and territories, except those sold through MTD PRODUCTS INC'S authorized channels of export distribution.

**Other Warranties:**

1. The engine or component parts thereof carry separate warranties from their manufacturers. Please refer to the applicable manufacturer's warranty on these items.
- \*2. Batteries are covered by a 90-day replacement warranty.
3. Log splitter pumps, valves and cylinders or component parts thereof are covered by a one year warranty.
4. All other warranties, express or implied, including any implied warranty of merchantability or fitness for a particular purpose, are hereby expressly disclaimed in their entirety.
5. The provisions as set forth in this warranty provide the sole and exclusive remedy of MTD PRODUCTS INC'S obligations arising from the sales of its products. MTD PRODUCTS INC will not be liable for incidental or consequential loss or damage.

**How state law relates to this warranty:** This limited warranty gives you specific legal rights, and you may also have other rights which vary from state to state. Certain disclaimers are not allowed in some states and therefore they may not apply to you under all circumstances.

**NOTE:** This warranty does not cover routine maintenance items such as lubricants, filters, blade sharpening and tune-ups, or adjustments such as brake adjustments, clutch adjustments or deck adjustments. Nor does this warranty cover normal deterioration of the exterior finish due to use or exposure.

## SERVICE NATIONWIDE

### HOW TO OBTAIN REPLACEMENT PARTS AND SERVICE

The merchandise you have purchased from us has been carefully engineered and manufactured under rigid quality standards and should give you satisfactory and dependable operation. However, like all mechanical merchandise, it may occasionally require adjustment, replacement parts or maintenance.

#### Toll Free Parts Sales Center

When you need a replacement part or accessory for a major appliance, home electronic item or lawn and garden product that is not under warranty or covered by a service contract or if you need the location of the nearest service facility, call our Parts Sales Center toll free 1-800-323-1965.

#### Provide the following:

1. Model, serial number and all of the other data shown on the model plate.
2. Also give the part number or numbers as shown in the parts list that came with the product.

Replacement Parts will be made available at current prices. If requested, prices will be quoted in advance when not listed.

If you order parts by mail, you will pay the transportation charges from the shipping point.

UNIT MODEL NO. \_\_\_\_\_

UNIT SERIAL NO. \_\_\_\_\_

ENGINE MODEL NO. \_\_\_\_\_

TYPE NO. \_\_\_\_\_

CODE NO. \_\_\_\_\_



**WARNING:** The Engine Exhaust from this product contains chemicals known to the State of California to cause cancer, birth defects or other reproductive harm.

PART NO. 770-8684L  
136Q690G088  
136S699H088  
136S699G088

PRINTED IN U.S.A.