

Sears

**owners
manual**

**MODEL NUMBER
580.328330**

**CAUTION: READ
INSTRUCTIONS AND
RULES FOR SAFE
OPERATION CAREFULLY
TO PREVENT
ACCIDENTS.**

**OPERATING
INSTRUCTIONS
REPAIR PARTS
ACCESSORIES**

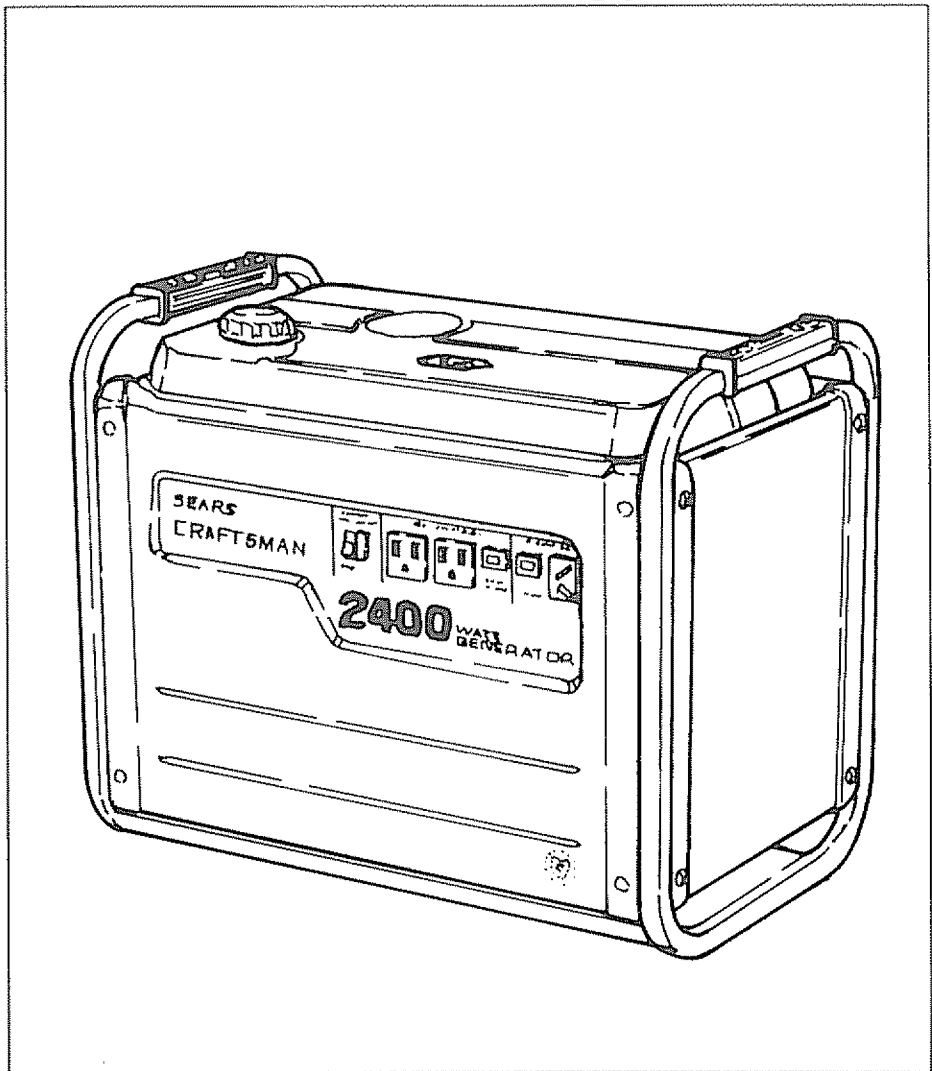

CRAFTSMAN®

**2400 WATT
PORTABLE
AC GENERATOR**

AC GENERATOR

Record in space provided below the Model No. and Serial No. of the generator. Model No. and Serial No. are both located on the Nameplate.

Model No. _____ Serial No. _____
Retain these numbers for future reference.

Sears, Roebuck and Co., Chicago, IL 60684 U.S.A.

FULL ONE YEAR WARRANTY

For one year from the date of purchase, Sears will repair any defect in material or workmanship in this Generator at no charge.

If the Generator is used for commercial or rental purposes, this warranty applies for only ninety days from the date of purchase.

Warranty service is available by RETURNING TO THE NEAREST SEARS SERVICE CENTER/DEPARTMENT THROUGHOUT THE UNITED STATES.

This warranty gives you specific legal rights, and you may also have other rights which vary from state to state.

Sears, Roebuck and Co.
Dept. 698/731A
Chicago, IL 60684

RULES FOR SAFE OPERATION

1. Never permit any unqualified person- especially children- to operate this equipment. Equipment misuse, carelessness, improper procedures, or incorrect application may result in personal injury or damage to equipment and/or property.
2. Never handle any kind of electrical device while standing in water, while barefoot, or while hands or feet are wet. Dangerous electrical shock will result.
3. The engine that drives the generator consumes oxygen and gives off deadly carbon monoxide gas through its exhaust system. This dangerous gas, when breathed in sufficient concentrations, can cause unconsciousness and even death. Operate this equipment only in well ventilated areas. Never operate this equipment in any room or enclosed space where exhaust gases might accumulate and endanger people.
4. This equipment requires an adequate free flow of cooling air for its operation. Without adequate cooling air flow, overheating and resultant damage to equipment and/or property will result. Never operate the generator inside any room or enclosure that might obstruct the free flow of cooling air into and out of the unit.
5. Engines, engine exhaust mufflers and surrounding areas on this equipment become extremely hot during operation and remain hot for several minutes after shutdown. Avoid contact with these areas or serious burns may result.
6. Gasoline is extremely flammable and its vapors are explosive. Do not permit smoking, open flame, or sparks in the vicinity while handling gasoline. Avoid spillage of gasoline on a hot engine. Never fill the gas tank while the engine is running. Comply with all laws regulating the storage and handling of gasoline.
7. Never store this equipment indoors or in enclosed, poorly ventilated enclosures with fuel in tank where gasoline fumes might reach an open flame, spark or pilot light (as on a furnace, water heater, clothes dryer, etc.).
8. In addition to these RULES FOR SAFE OPERATION, other SAFETY RULES may apply. Practice safety at all times- by staying alert and by reading the instructions in this Manual carefully.

AC GENERATOR SPECIFICATIONS

Model Number..... 580.328330
Type of Equipment..... Revolving Field a-c Generator
Rated Maximum Continuous a-c Power Capacity..... 2400 watts (2.40 kW)
Rated Maximum Continuous Load Current..... 20.0 a-c amperes
Generator Circuit Breaker Rating..... 20.0 a-c amperes
Rated Voltage..... 120 volts a-c
Phase..... Single Phase
Rated a-c Frequency..... 60 hertz at 3600 rpm
Number of Revolving Field Poles..... 2
Driven Speed of Revolving Field..... 3720 rpm at No-Load
Type of Revolving Field Excitation.. Direct Excited (Bridge Rectifier)
Rated Maximum Battery Charge Output..... 10 amperes at 12 volts d-c
Battery Charge Circuit Breaker Rating..... 10 d-c amperes

ENGINE SPECIFICATIONS

Engine Manufacturer..... KAWASAKI
Manufacturer's Model Number..... FA-210
Type of Engine..... Single Cylinder, 4-Stroke, Air Cooled
Rated Horsepower..... 5.0 at 3600 rpm
Fuel Consumption Ratio..... 0.68 lb/hp/hr (310 gr/hp/hr)
Displacement..... 12.67 Cubic Inches (207 cc)
Compression Ratio..... 6.4 to 1
Cylinder Block Material..... High Silicon Aluminum
Ignition System
Type..... Flywheel Magneto (with Breaker Points)
Recommended Spark Plug..... Resistor Type 14 mm*
 NGK..... BMR-6A
 CHAMPION..... RCJ-8
Set Spark Plug Gap to..... 0.023-0.027 inch (0.6-0.7 mm)
Set Breaker Point Gap to..... 0.01-0.02 inch (0.3-0.5 mm)
Ignition Timing..... Fixed at 23 degrees BTDC
Engine Speed Governor
Type..... Mechanical, Fixed Speed
Governor Setting..... 3720 rpm at No-Load**
Air Cleaner..... Semi-dry Type, washable polyurethane element with
 nylon brush
Starter..... Manual, Recoil Rope Type
Engine Crankcase Oil Capacity..... 1.27 U.S. pint (600 cc)
Recommended Oils..... Use oil classified "For Service SC, SD or SE"
 Primary Recommended Oil..... SAE 10W-30 Multiple Viscosity***
 Acceptable Substitute..... SAE 30 Oil
 SAE 10W-40 OIL IS NOT RECOMMENDED
Maximum Permissible Inclination for Continuous Operation
without Lubrication Problems..... 20 degrees any direction
Fuel Tank Capacity..... 2.34 U.S. gallons (9.0 liters)
Recommended Fuel
 Primary Recommended Fuel..... UNLEADED Automotive Gasoline****
 Acceptable Substitute..... Leaded REGULAR Grade Automotive Gasoline

- * Canada requires the use of RESISTOR spark plugs, in compliance with the radio noise limitations (radio frequency interference) order issued by the Ministry of Communications of the Canadian Telecommunications Regulations Branch.
- ** At 3720 rpm the generator's a-c output will be 62 hertz. This slightly high engine speed setting at no-load helps ensure that engine speed (and a-c frequency) do not drop excessively when heavier electrical loads are applied.
- *** Use of a multiple viscosity oil will contribute to easier starting in cold weather.
- **** Use of UNLEADED gasoline in a 4-cycle engine contributes to increased valve life by reducing lead and carbon deposits. A high quality REGULAR grade gasoline may be used, however, UNLEADED gasoline is the primary recommended fuel.

SECTION 1 - GENERAL INFORMATION

1.1- INTRODUCTION

This OWNER'S MANUAL has been prepared especially for the purpose of familiarizing personnel with the handling, operation and servicing of the applicable equipment. Study the Manual carefully and comply with all instructions. This will help prevent possible injury or damage to equipment and/or property, that might be caused by carelessness, equipment misuse or abuse, improper procedures, or incorrect application.

1.2- SAFETY

Prior to handling, operating or servicing this equipment, study the **RULES FOR SAFE OPERATION** at the front of this Manual carefully. All **RULES** must be complied with fully, to help avoid personal injury or damage to equipment and/or property.

The following definitions apply to DANGER, CAUTION and NOTE blocks found throughout this Manual:-

DANGER!

Under this heading will be found handling, operating and servicing instructions that, if not complied with fully, may result in personal injury.

CAUTION!

Under this heading will be found handling, operating and servicing instructions that, if not complied with fully, may result in damage to equipment.

NOTE

Under this heading will be found explanatory statements that require special emphasis.

1.3- EQUIPMENT DESCRIPTION

This equipment is a gasoline engine-driven, revolving field a-c generator set. The generator may be used to operate 120 volts, single phase, 60 hertz, a-c electrical devices requiring up to 2400 watts (2.4 kW) of electrical power or up to 20.0 a-c amperes of current. A circuit breaker will open the unit's a-c output circuit if the current requirements of connected electrical loads exceeds 20.0 a-c amperes.

The generator's revolving field (rotor) is directly attached to and driven by a 4-cycle, air-cooled, gasoline engine. Engine speed with no electrical loads connected to the generator is maintained at approximately 3720 rpm by a mechanical governor. Engine speed and generator a-c output frequency are directly proportional. Thus, at 3600 rpm a-c frequency will be 60 hertz; at 3720 rpm a-c frequency is 62 hertz. The slightly high engine speed setting at no-load helps ensure that engine speed (and a-c frequency) do not drop excessively under heavier electrical loads.

In addition to its a-c power capability, the generator may be used to recharge a discharged 12 volts, automotive or utility type storage battery. When properly connected to the discharged battery, an operating generator will supply a maximum charge rate of approximately 10 d-c amperes at 12 volts. The maximum rate of charge will gradually decrease as the connected battery approaches a 100 percent state of charge.

1.4- RECEIVING AND HANDLING

Upon receipt, completely remove the generator from its shipping carton and from any shipping pallet to which it might be attached. Remove all packing material from around the generator. Inspect the unit carefully for any damage that might have occurred during shipment.

In addition to this **OWNER'S MANUAL**, a **BATTERY CHARGE CABLE** is shipped with the generator. To order additional Manuals or Cables, refer to the **REPAIR PARTS** section of the Manual.

CAUTION!

DO NOT attempt to crank and start the generator engine until it has been properly prepared for use, as outlined in Section 2 of this Manual. Any attempt to crank or start the unit before it has been properly serviced with the recommended oil will result in an engine failure.

SECTION 2 - OPERATING INSTRUCTIONS

DO AND DON'T CHART

1. DO comply with all SAFETY RULES.

2. DO check oil level before start-up or at least every 5 hours of operation.

3. DO disconnect electrical loads from panel receptacles before starting or stopping the engine.

4. DO comply with instructions in this Manual when charging a battery.

5. DO operate the generator only on surfaces that are as level as possible.

1. DON'T operate the unit inside any enclosure that might obstruct the free flow of cooling air.

2. DON'T operate the unit inside any room or enclosure where exhaust fumes might accumulate and result in carbon monoxide poisoning.

3. DON'T overload the generator. The total of all connected loads should not exceed 2400 watts (2.4 kW), or 20.0 a-c amperes.

4. DON'T touch areas around the engine exhaust muffler. These areas are HOT.

5. DON'T handle electrical equipment while standing in water, while barefoot, or while hands or feet are wet.

2.1- PREPARATION BEFORE USE (Figure 2-1)

a. Check Engine Oil Level (Figure 2-1):- Check oil level and (if necessary) fill to proper level with the recommended oil as follows:-

(1) Place the generator on a level surface.

(2) Remove OIL FILL PLUG by turning counterclockwise.

(3) Check oil level. Oil should be at point of overflowing the OIL FILL PLUG opening. If necessary, add oil to that level. See **ENGINE SPECIFICATIONS CHART** at front of Manual for recommended oils and crankcase capacity.

(4) When oil is at proper level, install and tighten OIL FILL PLUG.

NOTE

The generator revolving field rotates on a pre-lubricated, sealed bearing which requires no additional lubrication for the life of the bearing.

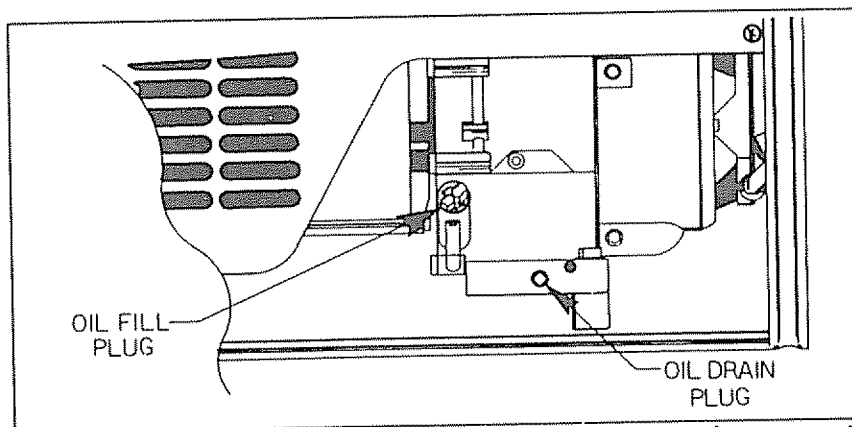

Figure 2-1. Engine Oil Fill and Oil Drain Locations

b. Fill Fuel Tank:- Remove Fuel Tank FILLER CAP by turning counterclockwise. Fill Fuel Tank with clean, fresh gasoline as recommended in the **ENGINE SPECIFICATIONS CHART** at front of Manual. Install and tighten FILLER CAP.

DANGER!

Gasoline is extremely **FLAMMABLE** and its vapors are **EXPLOSIVE**. **DO NOT** permit smoking, open flame or sparks in the vicinity while handling gasoline. Avoid spillage of gasoline on a hot engine. Comply with all laws regulating the storage and handling of gasoline. Never store the generator with fuel in tank where gasoline vapors might reach an open flame, spark or pilot light (such as on a furnace, water heater, dryer, etc.)- **FIRE** or an **EXPLOSION** might result.

c. 120 Volts Cord Sets:- Use only high quality, well insulated, grounded cord sets with the generator's 120 volts a-c receptacles. Wire gauge of cord sets must be large enough to handle the maximum anticipated current draw of connected electrical loads. Cord sets that are excessively long or that are rated at too low an amperage will cause a voltage drop and will overheat. Table 2-1 lists minimum recommended wire gauges, based on the cord set length and the load current draw in amperes.

LOAD CURRENT (AMPERES)	LENGTH OF CORD SET IN FEET		
	0-50	51-100	101-150
2-3	18 AWG	18 AWG	18 AWG
4-5	16 AWG	16 AWG	16 AWG
6	16 AWG	16 AWG	14 AWG
8	16 AWG	14 AWG	12 AWG
10	16 AWG	14 AWG	12 AWG
12	14 AWG	14 AWG	12 AWG
14	14 AWG	12 AWG	10 AWG
16	12 AWG	12 AWG	10 AWG
18	12 AWG	10 AWG	8 AWG
20	10 AWG	8 AWG	8 AWG

Table 2-1. Recommended Wire Gauges of 120 Volts Cord Sets

2.2- OPERATING LOCATION

Comply with the following rules pertaining to operating location of the generator:-

- a. Place the generator on a level surface. Maximum tilt of the engine in any direction must not exceed 20 degrees, or engine lubricating problems may result.
- b. Never operate the generator where it will be exposed to flooding, excessive moisture, dust, dirt or corrosive vapors.
- c. Provide adequate ventilation. Never operate the generator inside any room or enclosure where exhaust fumes might accumulate and endanger people.
- d. Never run the generator inside any room or enclosure that might obstruct the free flow of cooling air. Without adequate cooling air, the unit will quickly overheat, causing serious operating problems and possible damage to equipment and/or property.

2.3- DON'T OVERLOAD THE GENERATOR (Table 2-2)

DO NOT exceed the generator's rated WATTAGE and/or AMPERAGE capacity for continuous operation. Before connecting electrical loads to panel receptacles, add up the WATTS (or the AMPERES) required to operate those loads. Rated watts and/or amperage can usually be found on the nameplate of lights, appliances, motors, etc. The total of all loads being powered at one time should not exceed 2400 watts or 20.0 a-c amperes.

NOTE

Some electric motors (such as saws, drills, etc.) require more watts of power or amperes of current than is stated on their nameplate, when the motor is being put to hard use. For example, a saw that is used to cut through extremely difficult material may require 3 to 4 times more wattage or amperage than is stated on its nameplate.

Some electric motors (such as Universal, Repulsion-Induction, Capacitor, or Split Phase type) require more amperes of current for starting than for continuous on-speed operation. Approximate starting and running current (in amperes) is listed in Table 2-2. To use the chart, find the TYPE OF MOTOR and its RATED HORSEPOWER on the motor nameplate. Then, locate the approximate starting and running amperes in the chart.

MOTOR HORSEPOWER RATING	APPROXIMATE RUNNING AMPERES	APPROXIMATE STARTING AMPERES			
		UNIVERSAL MOTORS	REPULSION INDUCTION MOTORS	CAPACITOR MOTORS	SPLIT PHASE MOTORS
1/6	2.3	3.3	5.0	7.1	10.0
1/4	3.3	4.2	7.1	8.8	16.2
1/3	3.8	5.0	8.1	11.3	16.3
1/2	5.0	6.3	10.8	15.0	21.7
3/4	7.1	8.3	15.8	21.7	*
1	8.3	10.4	19.2	25.0	*
1-1/2	12.3	*	26.7	35.0	*
2	16.7	*	32.5	42.5	*
3	25.0	*	43.3	56.7	*
5	40.0	*	62.5	81.7	*

* Motors of higher horsepower in this classification are not generally used.

Table 2-2. Approximate Motor Running and Starting Requirements

2.4- STARTING THE ENGINE (Figure 2-2)

a. Disconnect Electrical Loads:- Disconnect or turn OFF all electrical loads connected to generator receptacles.

CAUTION!

Never start or stop the engine with electrical loads connected and turned on. The generator will supply its rated voltage and frequency only at its correct rated operating speed. Some electrical devices may be damaged by incorrect voltage and/or frequency. In addition, starting the engine with electrical loads applied imposes a heavy load at lower operating speeds where adequate power is not yet available and may shorten engine life.

- b. Close the Choke:- Rotate the CHOKE CONTROL to its FULL CHOKE position. Lesser amounts of choking may be required when starting a warm engine.
- c. Set Switch to RUN:- Set the Engine-Run/Stop Switch to its RUN position.
- d. Crank Engine:- Grasp the recoil starter handle with one hand while holding the generator carrying handle with other hand. Pull the starter handle out rapidly to overcome compression and prevent "kickback". Repeat, if necessary, with Choke opened slightly. When engine starts, open the Choke gradually.
- e. Let the engine stabilize and warm up for a few minutes.
- f. Check that the AC ON light is illuminated. Then connect and turn ON the desired electrical load(s). **DO NOT OVERLOAD THE GENERATOR- SEE PARAGRAPH 2.3.**

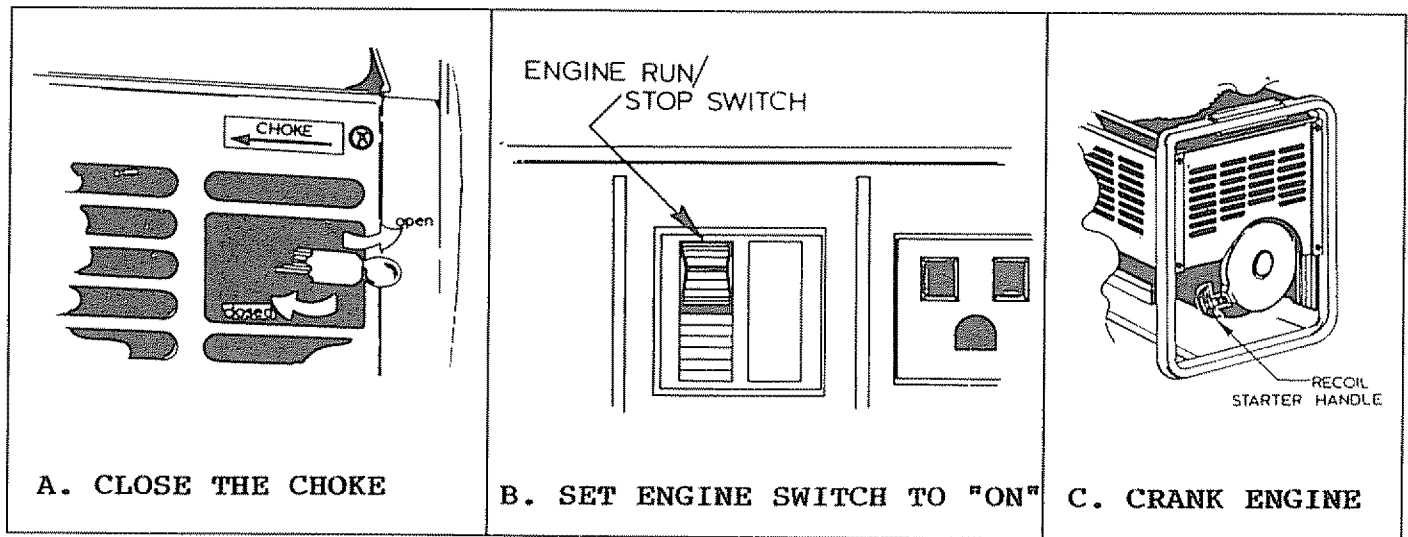

Figure 2-2. Starting the Engine

2.5- STOPPING THE ENGINE

- a. Disconnect (or turn OFF) all electrical loads connected to generator receptacles.
- b. Let the engine run for a minute or two at no-load, to cool.
- c. Set the Engine-Run/Stop Switch to STOP position. Wait for the engine to come to a complete stop.

2.6- CHARGING A BATTERY (Figure 2-3)

This equipment has battery charging capability, may be used to recharge a discharged 12 volts, automotive or utility type storage battery. To recharge a 12 volts battery, proceed as follows:-

CAUTION!

DO NOT attempt to recharge any 6 volts battery using the generator's battery charge system. **DO NOT** attempt to crank an engine having a discharged battery. Either of the preceding may result in damage to equipment.

a. Remove battery vent caps. Check that vent cap holes are not clogged. If necessary, use a length of fine wire to open holes in caps. Then, install vent caps onto battery.

DANGER!

Storage batteries give off **EXPLOSIVE** hydrogen gas while charging. **DO NOT** permit smoking, open flames, sparks, or spark producing equipment in the vicinity while charging a battery. **NEVER** use a match, lighter, or any other source of heat to provide lighting while checking battery fluid level. The danger of explosion is greatly diminished if battery vent caps are installed while charging.

b. Check electrolyte fluid level in all battery cells. If necessary, add **DISTILLED WATER** to bring fluid to the correct level. **DO NOT USE TAP WATER.**

DANGER!

Battery electrolyte fluid is an extremely caustic sulfuric acid solution that can cause severe burns. **DO NOT** permit fluid to contact eyes, skin, clothing, painted surfaces, wiring insulation, etc. If spillage occurs, flush the affected area with clear water immediately.

c. Insert the 2-prong plug of the Battery Charge Cable (shipped with unit) into the generator panel receptacle indicated by the words "12 VOLT D.C.".

d. Connect the Battery Charge Cable clamp with **RED** handle to the battery post or terminal indicated by a **POSITIVE, POS** or "+".

e. Connect the Battery Charge Cable clamp with **BLACK** handle to the battery post or terminal indicated by a **NEGATIVE, NEG** or "-".

f. Start the generator engine. The discharged battery will receive a maximum charge of up to 10 d-c amperes. This maximum charge rate will reduce as the battery approaches a 100 percent state of charge.

g. When the battery has recharged, shut the generator engine down. Then, disconnect the Battery Charge cable from the panel receptacle and from the battery posts or terminals.

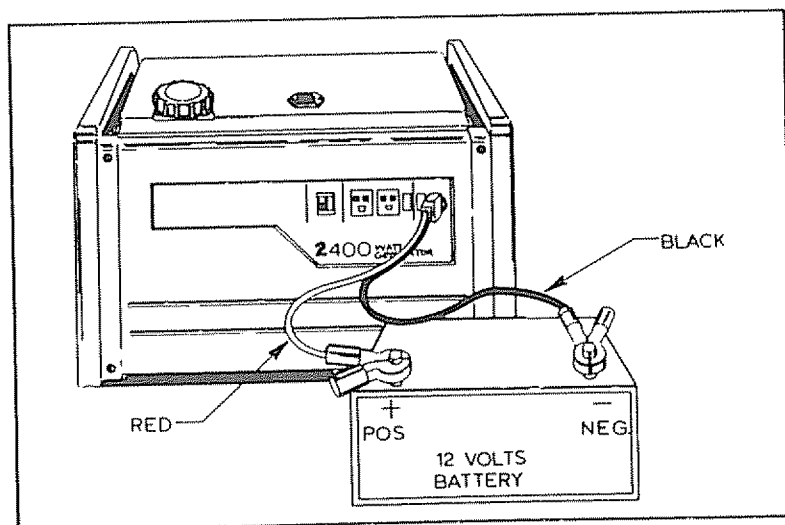

Figure 2-3. Charging a Battery

2.7- DETERMINING BATTERY STATE OF CHARGE AND CONDITION

Use an automotive type BATTERY HYDROMETER to determine battery **STATE OF CHARGE** and **CONDITION**. Follow the hydrometer manufacturer's instructions carefully.

Battery State of Charge:- Check the specific gravity of electrolyte fluid in all battery cells. Write down the reading of each cell as it is taken, then return the fluid to the cell from which it was withdrawn. When the specific gravity of the fluid in all cells is known, calculate the average specific gravity. If the hydrometer does not have a percentage of charge scale, compare the average reading obtained with the following:-

SPECIFIC GRAVITY	PERCENT OF CHARGE
1.260	100%
1.230	75%
1.200	50%
1.170	25%

If necessary, recharge the battery to a 100% STATE OF CHARGE.

EXAMPLE:- Readings obtained are 1.230; 1.220; 1.230; 1.210; 1.225; 1.230. Sum of all readings is 7.345. Divide by 6 to obtain the average of 1.224. The battery is less than 75% charged.

Determining Battery Condition:- If the difference in specific gravity between the highest and lowest reading cell is 0.050 (50 points) or more, the battery is nearing the end of its useful life and should be replaced. However, if the specific gravity of the highest reading cell is less than 1.200, the test for condition is questionable. Recharge the battery and repeat the test.

EXAMPLE:- Specific gravity readings are 1.230; 1.220; 1.230; 1.210; 1.225; 1.230. Battery condition is good. If readings are 1.250; 1.180; 1.240; 1.240; 1.240; 1.210- battery is worn out.

SECTION 3 - PERIODIC MAINTENANCE

MAINTENANCE TASK	HOURLY OPERATING INTERVAL					
	BEFORE USE	AFTER FIRST 20 HOURS	EVERY 50	EVERY 100	EVERY 200	OTHER
1. Check oil level	X					
2. Change Engine Oil		X		X		
3. Service Air Cleaner			X			
4. Clean Fuel Screen				X		
5. Decarbonize Muffler				X		
6. Replace Spark Plug					X	
7. Decarbonize Engine*				X		
8. Reface Valves*				X		
9. Check Valve Clearance*				X		
10. Prepare for Storage						X

* Tasks indicated by a single asterisk (*) should be accomplished by a qualified engine service technician.
 ** Prepare unit for storage if it is to remain idle longer than 30 days.

Table 3-1. Periodic Maintenance Chart

3.1- CHECK ENGINE OIL LEVEL

Check engine crankcase oil level prior to each use, or at least every 5 hours of operation. See Paragraph 2.1.

3.2- CHANGE ENGINE OIL (Figure 3-1)

Drain crankcase completely and refill with clean, fresh oil after the first 20 hours of operation, every 100 operating hours thereafter, as follows:-

- a. Operate engine until thoroughly warmed up, then shut down.

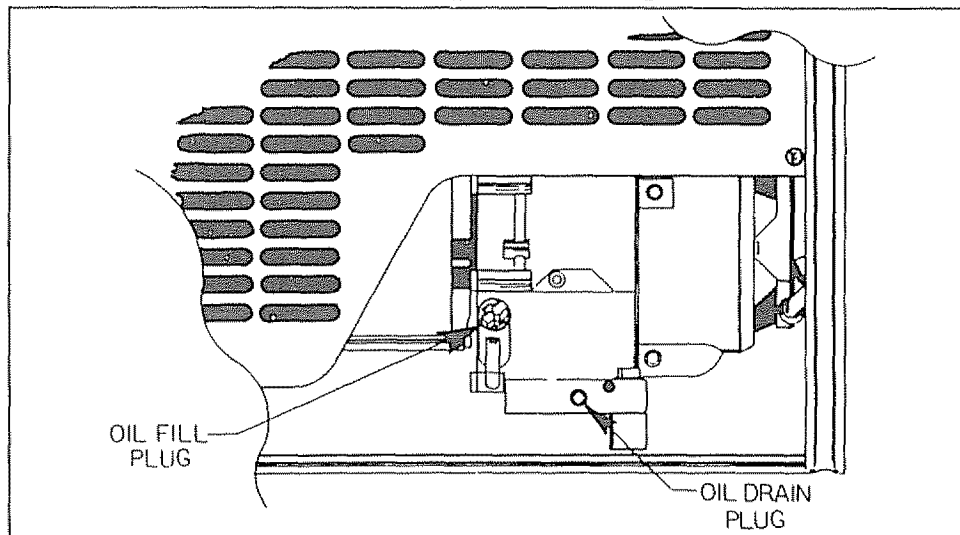

Figure 3-1. Engine OIL FILL and OIL DRAIN PLUGS

- b. Clean areas around OIL FILL and OIL DRAIN PLUGS, to prevent dirt from entering engine.
- c. Remove OIL FILL PLUG.
- d. Remove OIL DRAIN PLUG and drain oil completely into a suitable container.
- e. When all oil has drained, install OIL DRAIN PLUG. Tighten to 10 foot-pounds (1.4 kg-m).
- f. Refill with recommended oil through the OIL FILL PLUG opening. Pour slowly. Oil level is correct when oil reaches point of overflowing the OIL FILL PLUG opening. See ENGINE SPECIFICATIONS CHART at front of Manual for recommended oils.
- g. Install and tighten OIL FILL PLUG.

3.3- SERVICE AIR CLEANER (Figure 3-2, 3-3)

Service the engine air cleaner every 50 hours of operation, more frequently if operating under extremely dirty or dusty conditions. To service the air cleaner, proceed as follows:-

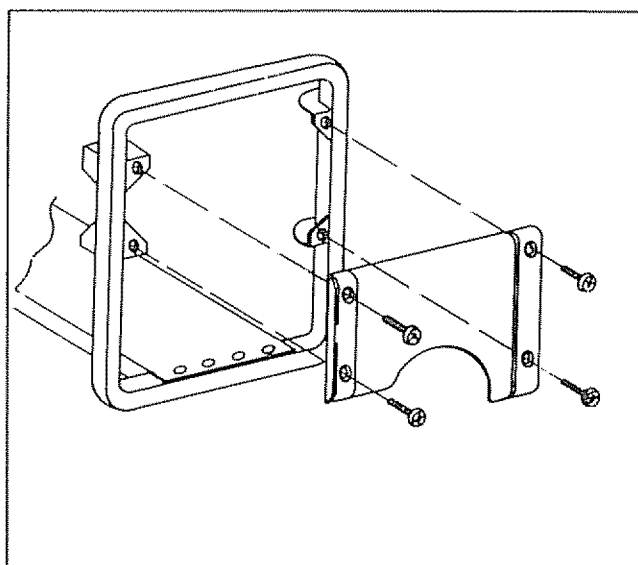

Figure 3-2. Remove End Panel

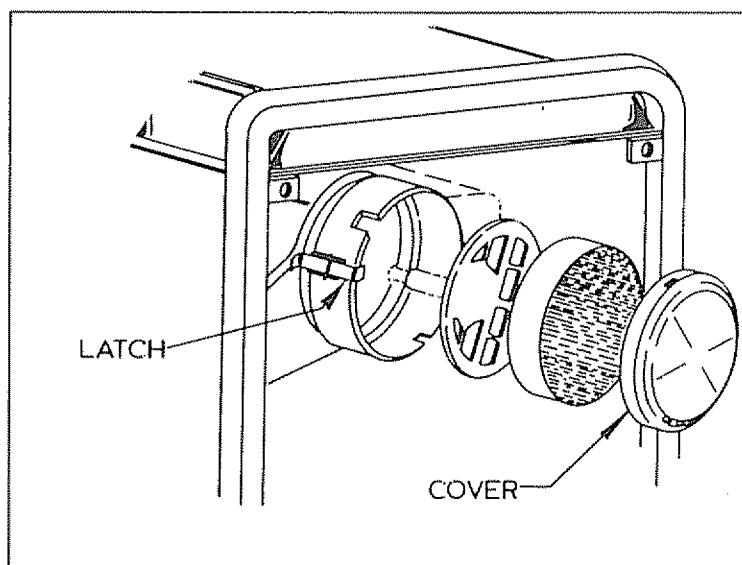

Figure 3-3. Air Cleaner Assembly

- a. Remove 4 screws that retain END PANEL to cradle, then remove END PANEL.
- b. Unsnap the LATCH, then remove COVER, ELEMENT and PLATE.
- c. Wash ELEMENT in kerosene. Squeeze dry.
- d. Saturate ELEMENT in clean, fresh engine oil. Squeeze to distribute oil and to remove excess oil.
- e. Wash PLATE in kerosene, dry with a clean, lint-free cloth.
- f. Install PLATE.
- g. Install ELEMENT with nylon "brushes" facing outward.
- h. Engage slot on COVER with tang on air cleaner CASE, install COVER and retain with LATCH.

3.4- CLEAN FUEL SCREEN (Figure 3-4)

Remove, clean and inspect FUEL SCREEN every 50 hours of operation. Remove FUEL TANK CAP, BREATHER, GASKET and FILTER. Clean BREATHER and FUEL SCREEN in clean gasoline. Replace any damaged or defective component. Reinstall in reverse order of removal.

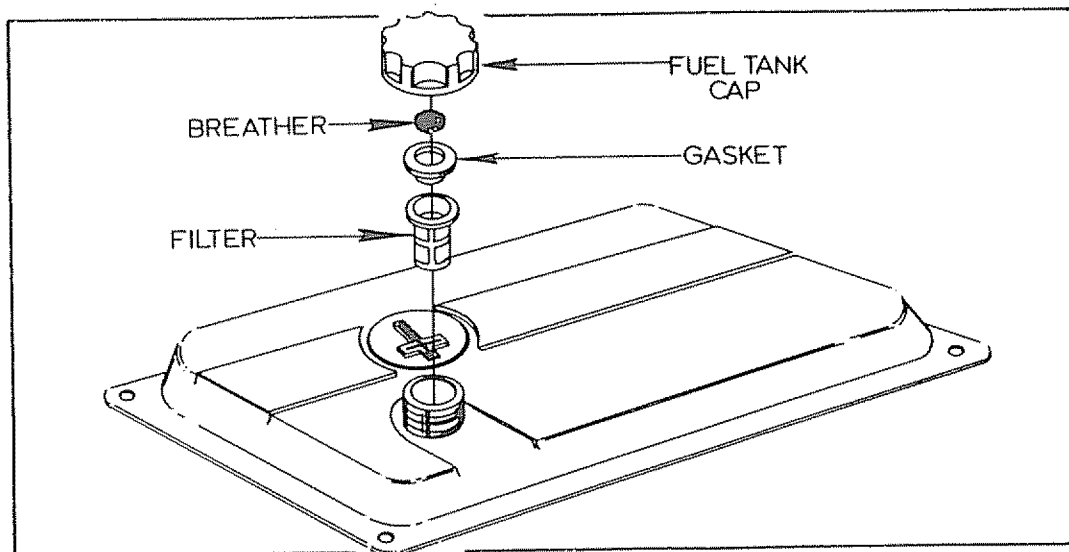

Figure 3-4. Fuel Tank Cap, Breather, Gasket and Filter

3.5- DECARBONIZE MUFFLER (Figure 3-5)

The engine is equipped with a SPARK ARRESTOR type exhaust muffler. Decarbonize the muffler every 50 hours of operation, as follows:-

NOTE

This equipment, when used on any forest covered, brush covered or grass covered land requires a SPARK ARRESTOR. The SPARK ARRESTOR must be maintained in effective working order by the operator. In the State of California, the preceding is required by law (Section 4442 of the California Public Resources Code). Other states may have similar laws. Federal laws apply on federal lands.

- a. Remove 4 screws that retain rear PANEL to cradle, then remove the rear PANEL.
- b. Remove SCREWS that retain SPARK ARRESTOR SCREEN and GASKET to exhaust muffler.
- c. Remove SPARK ARRESTOR SCREEN.
- d. Inspect GASKET, replace if damaged or defective.
- e. Clean SPARK ARRESTOR SCREEN in non-flammable solvent. Replace SCREEN if torn, perforated, excessively dirty, or otherwise damaged or defective.
- f. Start the generator engine and let run for about 5-10 minutes to blow out carbon and condensation. Then, shut the engine down and let it cool.
- g. When engine and exhaust muffler are cool, install GASKET and SPARK ARRESTOR SCREEN. Retain with SCREWS.

DANGER!

DO NOT touch a hot muffler or any hot adjacent parts, or serious burns may result.

- e. Inspect GASKET. Replace if torn or otherwise damaged.
- f. Install GASKET and PLATE, retain with SCREWS.

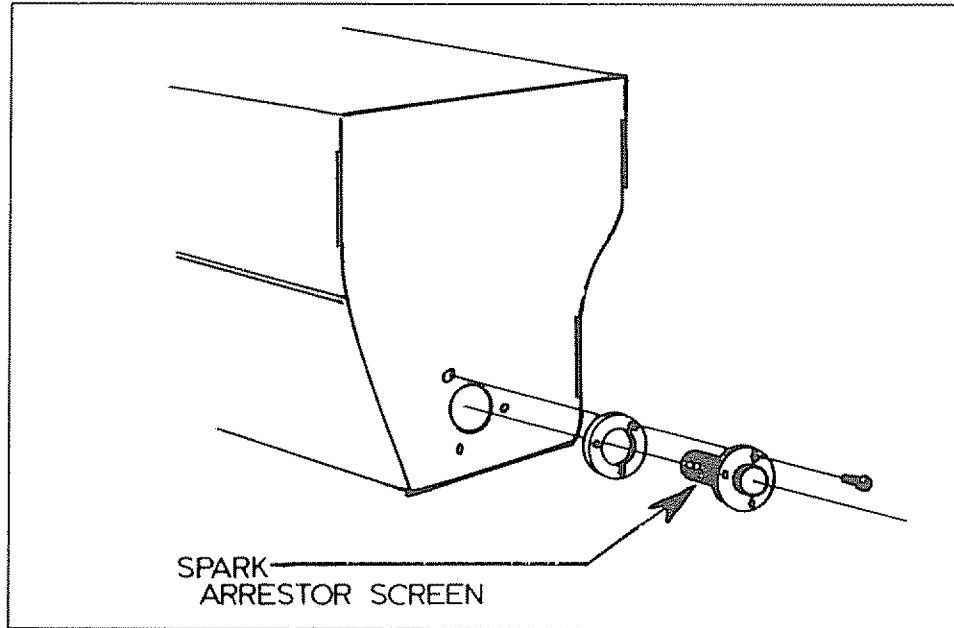

Figure 3-5. Spark Arrestor Screen

3.6- REPLACE SPARK PLUG (Figure 3-6)

Replace spark plug every 200 hours of operation, or if damaged or defective. Use replacement spark plug as recommended in ENGINE SPECIFICATIONS CHART at front of Manual. Set gap on new or used spark plug to 0.023-0.027 inch (0.6-0.7 mm).

- a. Remove COVER by prying upward.
- b. Use a spark plug socket wrench to remove spark plug.
- c. Set gap on spark plug as specified.
- d. Install spark plug with gasket. Tighten plug by hand until it is firmly seated. Then, tighten an additional 3/4 to 1 turn using a socket wrench.
- e. Install COVER.

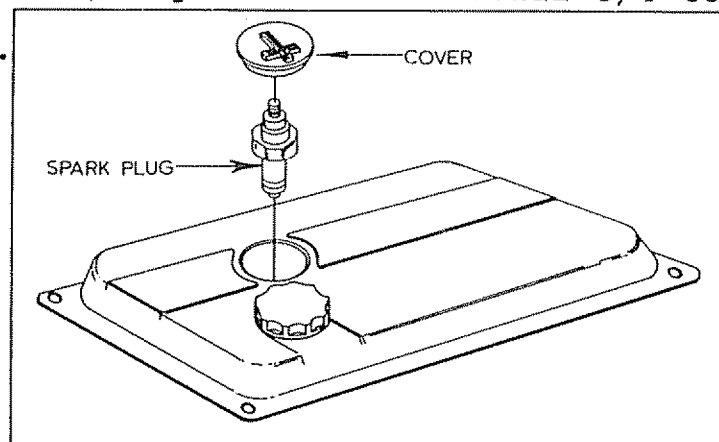

Figure 3-5. Spark Plug Removal

3.7- DECARBONIZE ENGINE, REFACE VALVES, CHECK VALVE CLEARANCE

Have the carbon cleaned from the engine combustion area (cylinder head, valves, piston) every 100 hours of operation. At the same time, have the valves refaced and adjusted by an engine service technician.

3.8- PREPARE UNIT FOR STORAGE

If the unit is to be unused for longer than 30 days, prepare it for storage as follows:-

- a. Operate the engine until it runs out of gas.
- b. Let the engine cool.
- c. When engine has cooled, remove spark plug (see Paragraph 3.6). Then, pour about 2 or 3 tablespoons of clean, fresh engine oil into spark plug opening in engine cylinder head. Crank engine several times to distribute oil.
- d. Install spark plug and spark plug access cover.
- e. Slowly pull starter handle out until resistance is felt, indicating that engine is on its compression stroke. This will close both valves, to prevent rusting of the cylinder interior.
- f. Wipe exterior surface of engine and generator with an oil-soaked cloth.
- g. Cover the generator and store in a clean, dry place.

Parts Catalog

Sears

CRAFTSMAN®

2400 WATT
PORTABLE
AC GENERATOR

MODEL NUMBER 580.328330

EXPLODED VIEW OF 2400 WATT AC GENERATOR
Drawing Number 65798-A

AC GENERATOR
MODEL NUMBER 580.328330

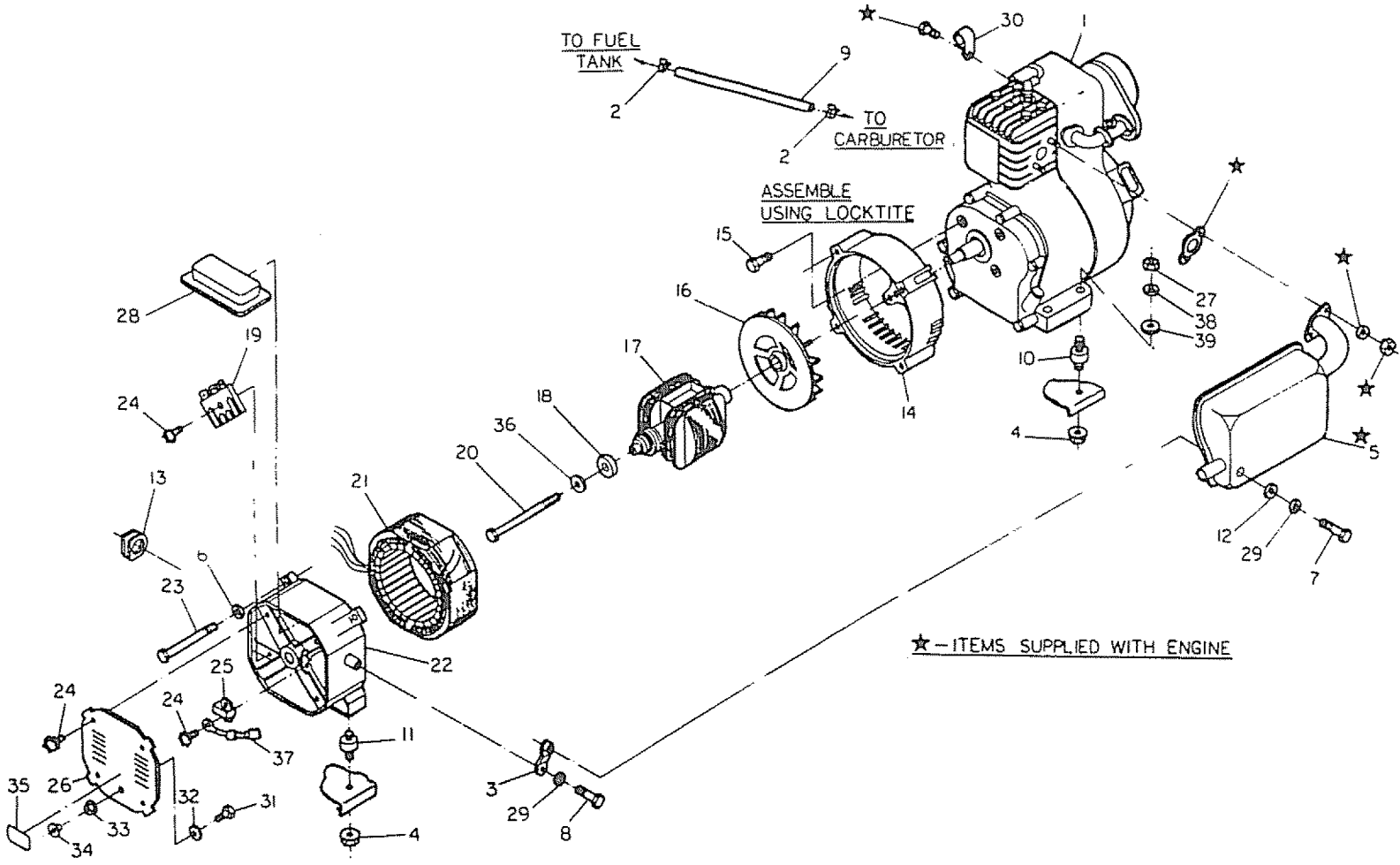

EXPLODED VIEW OF AC GENERATOR
Drawing Number 65798-A

EXPLODED VIEW OF AC GENERATOR
Drawing Number 65798-A

ITEM	PART NUMBER	DESCRIPTION
1	65188	ENGINE- 5 Horsepower Kawasaki- FA210 (1 Req'd)
2	66836	CLAMP, Fuel Line (2 Req'd)
3	66462	BRACKET, Muffler Support (1 Req'd)
4	66834	NUT, Flanged Lock- M8-1.25 (4 Req'd)
5	66432	MUFFLER, Spark Arrest (1 Req'd)
6	22097	WASHER, Lock- M6 (4 Req'd)
7	52243	CAPSCREW, Hex Head- M10-1.50 x 60mm (1 Req'd)
8	51755	CAPSCREW, Hex Head- M10-1.50 x 16mm (1 Req'd)
9	66837	HOSE, Fuel- 300mm long (1 Req'd)
10	66443A	MOUNT, Vibration- Engine (2 Req'd)
11	66443B	MOUNT, Vibration- Generator (2 Req'd)
12	49809	WASHER, Flat- M10 (1 Req'd)
13	67022	GROMMET, Lead Outlet (1 Req'd)
14	66365	HOUSING, Engine Adapter (1 Req'd)
15	39253	CAPSCREW, Hex Head- M8-1.25 x 20mm (4 Req'd)
16	66389	FAN, Cooling (1 Req'd)
17	65785	ROTOR ASSEMBLY (1 Req'd)
18	65791	BEARING, Ball (1 Req'd)
19	65795	RECTIFIER, Battery Charge (1 Req'd)
20	66448B	BOLT, Rotor- M8-1.25 x 190mm (1 Req'd)
21	66454	STATOR ASSEMBLY (1 Req'd)
22	66825	CARRIER, Rear Bearing (1 Req'd)
23	66449B	BOLT, Stator- M6-1.00 x 90mm (4 Req'd)
24	66849	SCREW (Taptite)- M5-0.80 x 15mm (7 Req'd)
25	66386	ASSEMBLY, Brush (1 Req'd)
26	67025	COVER, Bearing Carrier (1 Req'd)
27	45771	NUT, Hex- M8-1.25 (2 Req'd)
28	66850	BOARD, Bridge Rectifier (1 Req'd)
29	46526	WASHER, Lock- M10 (2 Req'd)
30	66894	CLAMP, Fuel Line Support (1 Req'd)
31	49815	SCREW, Machine- M5-0.80 (1 Req'd)
32	67444	WASHER, Serrated- M5 (1 Req'd)
33	52856	NUT, Flanged Lock- M5-0.80 (1 Req'd)
34	67435	NUT, Wing- M5-0.80 (1 Req'd)
35	67210	DECAL- Ground (1 Req'd)
36	67451	WASHER, Flat (Special)- M8 (1 Req'd)
37	67462	DIODE ASSEMBLY (1 Req'd)
38	22129	WASHER, Lock- M8 (2 Req'd)
39	49810	WASHER, Flat- M8 (2 Req'd)

EXPLODED VIEW OF CRADLE- 2400 WATT GENERATORS (Sears 580.328330)
Drawing Number 65799-A

ITEM	PART NUMBER	DESCRIPTION
1	66394	BASE, Engine Cradle (1 Req'd)
2	66456	PANEL- Engine End (1 Req'd)
3	66457	PANEL, Muffler (1 Req'd)
4	66453	PANEL, Generator End (1 Req'd)
5	66455	PANEL, Receptacle and Control (1 Req'd)
6	66817	SWITCH, Engine-Run/Stop (1 Req'd)
7	66818	RECEPTACLE- 120 Volts a-c, 15 Ampere (2 Req'd)
8	66819	BREAKER, Circuit- 20 a-c Amperes (1 Req'd)
9	66820	BREAKER, Circuit- 10 d-c Amperes (1 Req'd)
10	66821	RECEPTACLE- 12 Volts d-c (1 Req'd)
11	66822	RETAINER, 12 Volts d-c Receptacle (1 Req'd)
12	66828	SCREW, Machine- M3-0.50 x 5mm (2 Req'd)
13	66827	SCREW, Machine (with Lock Washer)- M5-0.80 x 12mm (25 Req'd)
14	66450	COVER, Handle (4 Req'd)
15	66368	TANK, Fuel- 2.34 U.S. Gallons (1 Req'd)
16A	66802A	CAP, Fuel Tank (1 Req'd)
16B	66802B	BREATHER, Fuel Tank (1 Req'd)
16C	66802C	GASKET, Fuel Tank Cap (1 Req'd)
17	64680B	COVER, Spark Plug Access (1 Req'd)
18	66391-B	INDICATOR, Fuel Level (1 Req'd)
19	65787	CABLE, Battery Charge (1 Req'd)
20	65788	DECAL, Receptacle and Control Panel (1 Req'd)
21	66392	CRADLE, Engine End (1 Req'd)
22	66393	CRADLE, Generator End (1 Req'd)
23	66397D	PLATE, Data (1 Req'd)
24	66829	RIVET- 3 mm (2 Req'd)
25	66823	DECAL, Choke (1 Req'd)
26	66824	DECAL- Hot Caution (1 Req'd)
27	66398C	DECAL- Starting Data (1 Req'd)
28	67103	DECAL- Warranty (1 Req'd)
29	67459	SCREW (Crimptite)- (8 Req'd)
30	66831	RIVET, Black Anodized- 4mm (8 Req'd)
31	66864	DECAL- U.S.D.A. (1 Req'd)
32	66838	FILTER, Fuel (1 Req'd)
33	66880	SHIELD, Fuel Tank Heat (1 Req'd)
34	66839	NUT, Hex Lock- M5-0.80 (6 Req'd)
35	52749	SCREW, Machine- M5-0.80 x 12 mm (2 Req'd)
36	52619	SCREW, Machine- M5-0.80 x 20mm (1 Req'd)
37	67444	WASHER, Serrated- M5 (1 Req'd)
38	51716	NUT, Hex - M5-0.80 (1 Req'd)
39	66395-21	WIRE, Ground (Green)- (1 Req'd)
40*	-----	DECAL- Unleaded Fuel
41*	-----	DECAL- Air Cleaner
42*	-----	DECAL- Lubrication
++	66832A	MANUAL, Owner's (1 Req'd)

* These Parts Supplied with Engine

++ NOT SHOWN

EXPLODED VIEW OF KAWASAKI 5 HORSEPOWER ENGINE

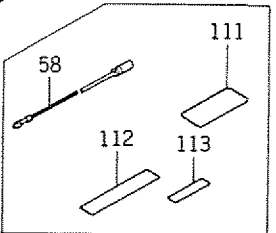
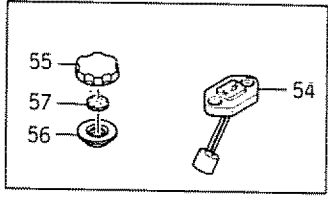
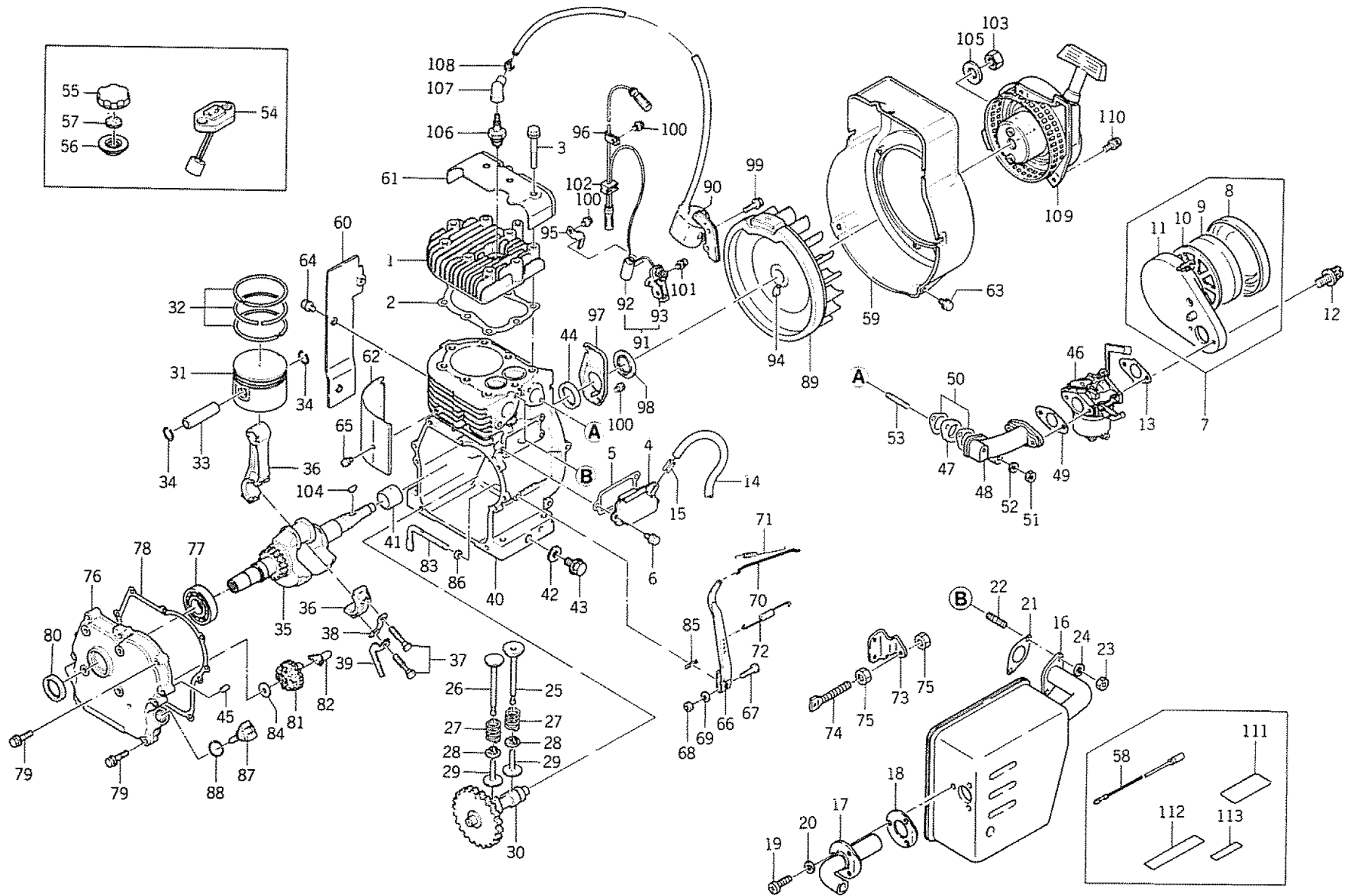

EXPLODED VIEW OF KAWASAKI 5 HORSEPOWER ENGINE

ITEM	PART NUMBER	DESCRIPTION	ITEM	PART NUMBER	DESCRIPTION
1	100-65188	HEAD,Cylinder	56	66802C	GASKET
2	101-65188	GASKET, Cylinder Head	57	66802B	BREATHER
3	102-65188	BOLT (8 x 55)	58	156-65188	WIRE
4	103-65188	COVER, ValveChamber	59	157-65188	HOUSING Fan
5	104-65188	GASKET	60	158-65188	CASE, Spiral
6	105-65188	BOLT (6 x 12)	61	159-65188	COVER, Cylinder Head
7	106-65188	CLEANER ASSEMBLY, Air	62	160-65188	COVER, Cylinder
8	107-65188	COVER, Air Cleaner	63	161-65188	BOLT (6 x 10)
9	108-65188	ELEMENT	64	105-65188	BOLT (6 x 12)
10	109-65188	PLATE Air Cleaner	65	162-65188	SCREW (5 x 10)
11	110-65188	CASE, Air Cleaner	66	163-65188	ARM, Governor
12	111-65188	BOLT (6 x 80)	67	164-65188	BOLT (6 x 25)
13	112-65188	GASKET	68	153-54188	NUT (6 mm)
14	113-65188	TUBE, Rubber	69	154-65188	WASHER
15	114-65188	PIPE	70	165-65188	ROD, Governor
16	66432	MUFFLER, Exhaust (Complete)	71	166-65188	SPRING, Link
17	115-65188	ARRESTER, Spark	72	167-65188	SPRING, Governor
18	116-65188	GASKET	73	168-65188	BRACKET
19	117-65188	SCREW	74	169-65188	ADJUSTER Spring
20	118-65188	WASHER	75	170-65188	NUT (6 mm)
21	119-65188	GASKET	76	171-65188	BASE, Side
22	120-65188	STUD	77	172-65188	BEARING, Ball (6205)
23	121-65188	NUT (8 mm)	78	173-65188	GASKET
24	122-65188	WASHER	79	174-65188	BOLT (6 x 30)
25	123-65188	VALVE Intake	80	175-65188	SEAL Oil
26	124-65188	VALVE Exhaust	81	176-65188	GOVERNOR
27	125-65188	SPRING, Valve	82	177-65188	SLEEVE Governor
28	126-65188	SEAT, Valve Spring	83	178-65188	TIP, Governor
29	127-65188	TAPPET	84	179-65188	WASHER
30	128-65188	CAMSHAFT	85	180-65188	PIN Snap
31	129-65188	PISTON (Standard)	86	181-65188	WASHER
	130-65188	PISTON (0 25mm OS)	87	182-65188	GAUGE Oil Level
	131-65188	PISTON (0 50mm OS)	88	183-65188	O-RING
32	132-65188	SET, Piston Ring (Standard)	89	184-65188	FLYWHEEL
	133-65188	SET, Piston Ring (0 25mm OS)	90	185-65188	COIL, Ignition
	134-65188	SET, Piston Ring (0 50mm OS)	91	186-65188	BREAKER ASS'Y Contact
33	135-65188	PIN, Piston	92	187-65188	CONDENSER
34	136-65188	RING Snap	93	188-65188	BREAKER, Contact
35	137-65188	CRANK SHAFT	94	189-65188	BRUSH
36	138-65188	ROD ASSEMBLY, Connecting	95	190-65188	CLAMP
37	139-65188	BOLT Connecting Rod	96	191-65188	CLAMP
38	140-65188	WASHER Lock	97	192-65188	COVER
39	141-65188	ARM, Splasher	98	193-65188	RING
40	142-65188	CASE ASSEMBLY, Connecting	99	194-65188	BOLT (5 x 20)
41	143-65188	BEARING, Plain	100	195-65188	SCREW (4 x 8)
42	144-65188	GASKET	101	196-65188	SCREW (4 x 20)
43	145-65188	BOLT (10 x 14)	102	197-65188	GROMMET
44	146-65188	SEAL, Oil	103	198-65188	NUT (14 mm)
45	147-65188	PIN, Dowel	104	199-65188	KEY
46	148-65188	CARBURETOR	105	200-65188	WASHER
47	149-65188	INSULATOR	106	201-65188	SPARK PLUG*
48	150-65188	PIPE, Inlet	107	202-65188	CAP, Plug
49	151-65188	GASKET	108	203-65188	SPRING
50	152-65188	GASKET	109	204-65188	STARTER ASSEMBLY Recoil
51	153-65188	NUT (6 mm)	110	205-65188	BOLT (6 x 10)
52	154-65188	WASHER	111	206-65188	DECAL
53	155-65188	STUD	112	207-65188	DECAL
54	66391B	GAUGE, Fuel Level	113	208-65188	DECAL
55	66802A	CAP, Fuel Tank			

* Use NGK-BMR6A, CHAMPION RCJ8, or equivalent spark plug

CARBURETOR

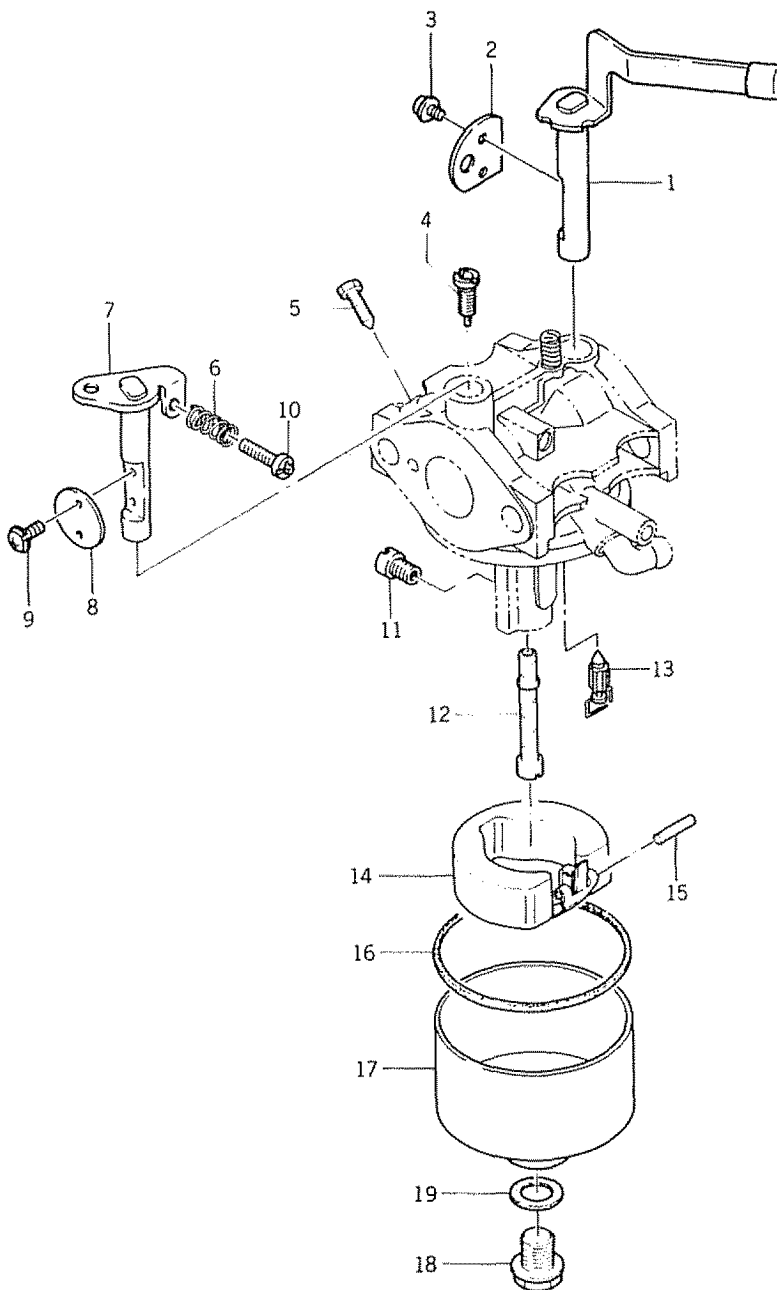

EXPLODED VIEW OF CARBURETOR

ITEM	PART NUMBER	DESCRIPTION	ITEM	PART NUMBER	DESCRIPTION
	148-65188	CARBURETOR ASSEMBLY	11	219-65188	JET, Main (#77 5)
1	209-65188	SHAFT, Choke	12	220-65188	NOZZLE, Main (#5A)
2	210-65188	VALVE, Choke	13	221-65188	VALVE, Needle
3	211-65188	SCREW	14	222-65188	FLOAT
4	212-65188	JET, Pilot (#37 5)	15	223-65188	PIN, Float
5	213-65188	SCREW, Pilot	16	224-65188	GASKET
6	214-65188	SPRING	17	225-65188	CHAMBER, Float
7	215-65188	SHAFT, Throttle	18	226-65188	BOLT
8	216-65188	VALVE, throttle	19	227-65188	GASKET
9	217-65188	SCREW			
10	218-65188	SCREW, Stop			

RECOIL STARTER

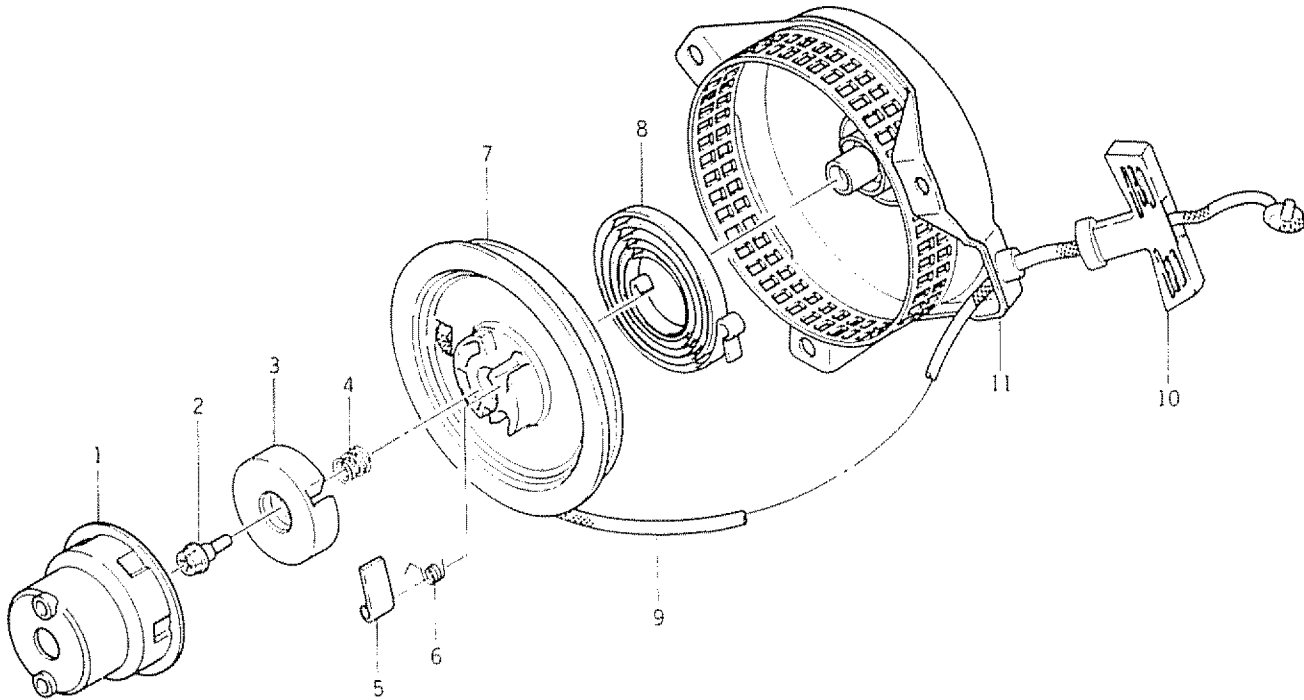

EXPLODED VIEW OF RECOIL STARTER

ITEM	PART NUMBER	DESCRIPTION
	204-65188	STARTER ASSEMBLY, Recoil
1	228-65188	PULLEY
2	229-65188	BOLT
3	230-65188	RETAINER
4	231-65188	SPRING
5	232-65188	PAWL, Recoil
6	233-65188	SPRING, Return
7	234-65188	REEL, Recoil
8	235-65188	SPRING, Recoil
9	236-65188	ROPE (4 5 x 1550)
10	237-65188	HANDLE, Recoil Starter
11	238-65188	CASE, Recoil Starter

Sears

**owners
manual**

MODEL NO. 580.328330

SERVICE

**HOW TO ORDER
REPAIR PARTS**

**PORTABLE
AC GENERATOR**

Now that you have purchased your Alternator, should a need ever exist for repair parts or service, simply contact any Sears Service Center and most Sears, Roebuck and Co. stores. Be sure to provide all pertinent facts when you call or visit.

The model number of your Alternator will be listed on the data plate.

**WHEN ORDERING REPAIR PARTS,
ALWAYS GIVE THE FOLLOWING INFORMATION:**

- PART NUMBER • PART DESCRIPTION
- MODEL NUMBER • NAME OF ITEM

All parts listed may be ordered from any Sears Service Center and most Sears stores.

If the parts you need are not stocked locally, your order will be electronically transmitted to a Sears Repair Distribution center for handling.