



Freezer

Use & Care Guide

Congelador

Guía para su uso y cuidado

Congélateur

Guide d'utilisation et d'entretien



Sears, Roebuck and Co., Hoffman Estates, IL 60179 U.S.A.
Sears Canada, Inc., Toronto, Ontario, Canada M5B 2B8

www.sears.com
297208300 (September 2007)

ENGLISH

ESPAÑOL

FRANÇAIS



Congratulations on your purchase of a new freezer! We are very proud of our product and we are completely committed to providing you with the best service possible. Your satisfaction is our #1 priority.

We know you'll enjoy your new freezer and **Thank You** for choosing our product. We hope you consider us for future purchases.

PLEASE READ AND SAVE THESE INSTRUCTIONS

This Owner's Guide provides specific operating instructions for your model. Use your freezer only as instructed in this manual. These instructions are not meant to cover every possible condition and situation that may occur. Common sense and caution must be practiced when installing, operating and maintaining any appliance.

Please record your model and serial numbers below for future reference. This information is found on the serial plate located inside the freezer compartment.

NOTE

Use only soap and water to clean serial plate.

Model Number: _____

or: _____

Serial Number: _____

Purchase Date: _____

TABLE OF CONTENTS

Welcome & Congratulations2

Important Safety Instructions 2-3

Warranty Information.....3

Protection Agreements4

Installation 5-6

Temperature Control6

Freezer Features7

Energy Saving Tips8

Power Failure/Freezer Failure8

Ice Service9

Care & Cleaning10

Before You Call..... 11-13

WARNING

Please read all instructions before using this freezer.

FOR YOUR SAFETY

- Do not store or use gasoline, or other flammable liquids in the vicinity of this or any other appliance. Read product labels for warnings regarding flammability and other hazards.
- Do not operate the freezer in the presence of explosive fumes.
- Avoid contact with any moving parts of automatic ice maker.
- Remove all staples from the carton. Staples can cause severe cuts, and also destroy finishes if they come in contact with other appliances or furniture.

CHILD SAFETY

Destroy or recycle the carton, plastic bags, and any exterior wrapping material immediately after the freezer is unpacked. Children should **NEVER** use these items to play. Cartons covered with rugs, bedspreads, plastic sheets or stretch wrap may become airtight chambers, and can quickly cause suffocation.

PROPER DISPOSAL OF YOUR REFRIGERATOR OR FREEZER

Risk of child entrapment

Child entrapment and suffocation are not problems of the past. Junked or abandoned refrigerators or freezers are still dangerous – even if they will sit for “just a few days.” If you are getting rid of your old refrigerator or freezer, please follow the instructions below to help prevent accidents.

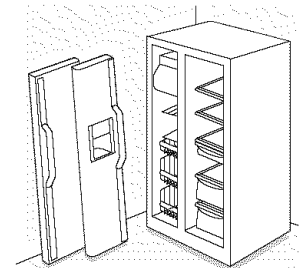

Before you throw away your old refrigerator/freezer:

- Remove doors.
- Leave shelves in place so children may not easily climb inside.
- Have refrigerant removed by a qualified service technician.

WARNING

These guidelines must be followed to ensure that safety mechanisms in this freezer will operate properly.

ENGLISH



ELECTRICAL INFORMATION

- Refer to the serial plate for correct electrical rating. The power cord of the appliance is equipped with a three-prong grounding plug for your protection against shock hazards. It must be plugged directly into a properly grounded three-prong receptacle. The power supply circuit must be installed in accordance with current edition of the National Electrical Code (NFPA 70) and local codes and ordinances. Consult a qualified electrician. Receptacles protected by Ground Fault Circuit Interrupters (GFCI) are NOT RECOMMENDED. **Do not use an extension cord or adapter plug.**
- If voltage varies by 10% or more, freezer performance may be affected. Operating freezer with insufficient power can damage the motor. Such damage is not covered under the warranty. If you suspect your house hold voltage is high or low, consult your power company for testing.
- To prevent the freezer from being turned off accidentally, do not plug unit into an outlet controlled by a wall switch or pull cord.
- Do not pinch, knot, or bend the cord in any manner.
- To defrost freezer, always unplug unit first.
- Never unplug the freezer by pulling on the cord. Always grip the plug firmly, and pull straight out from the receptacle.



IMPORTANT

Turning the temperature control to OFF turns off the compressor, but does not disconnect the power to the light bulb and other electrical components.

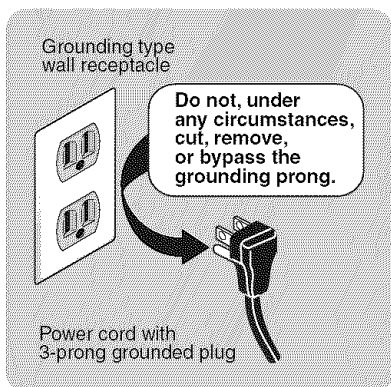

**KENMORE ELITE APPLIANCE WARRANTY
One Year Limited Warranty**

When installed, operated and maintained according to all instructions supplied with the product, if this appliance fails due to a defect in material or workmanship within one year from the date of purchase, call 1-800-4-MY-HOME® to arrange for free repair.

LIMITED FIVE YEAR WARRANTY ON SEALED REFRIGERATION SYSTEM

For five years from the date of purchase, when this appliance is installed, operated and maintained according to the instructions supplied with it, Sears will repair the sealed system (consisting of refrigerant, connecting tubing, and compressor), free of charge, if defective in material or workmanship.

If this appliance is used for other than private family purposes, this warranty applies for only 90 days from the date of purchase.

This warranty covers only defects in material and workmanship. Sears will NOT pay for:

1. Expendable items that can wear out from normal use, including but not limited to filters, belts, light bulbs and bags.
2. A service technician to instruct the user in correct product installation, operation or maintenance.
3. A service technician to clean or maintain this product.
4. Damage to or failure of this product if it is not installed, operated or maintained according to all instructions supplied with the product.
5. Damage to or failure of this product resulting from accident, abuse, misuse or use for other than its intended purpose.
6. Damage to or failure of this product caused by the use of detergents, cleaners, chemicals or utensils other than those recommended in all instructions supplied with the product.
7. Damage to or failure of parts or systems resulting from unauthorized modifications made to this product.

Disclaimer of implied warranties; limitation of remedies

Customer's sole and exclusive remedy under this limited warranty shall be product repair as provided herein. Implied warranties, including warranties of merchantability or fitness for a particular purpose, are limited to one year or the shortest period allowed by law. Sears shall not be liable for incidental or consequential damages. Some states and provinces do not allow the exclusion or limitation of incidental or consequential damages, or limitations on the duration of implied warranties of merchantability or fitness, so these exclusions or limitations may not apply to you.

This warranty applies only while this appliance is used in the United States and Canada.

This warranty gives you specific legal rights, and you may also have other rights which vary from state to state.

Sears, Roebuck and Co., Dept. 817WA, Hoffman Estates, IL 60179

Sears Canada Inc., Toronto, Ontario, Canada M5B 2B8

ENGLISH



Protection Agreements

Master Protection Agreements

Congratulations on making a smart purchase. Your new Kenmore® product is designed and manufactured for years of dependable operation. But like all products, it may require preventive maintenance or repair from time to time. That's when having a Master Protection Agreement can save you money and aggravation.

The Master Protection Agreement also helps extend the life of your new product. Here's what the Agreement* includes:

- ☑ **Parts and labor** needed to help keep products operating properly **under normal use**, not just defects. Our coverage goes **well beyond the product warranty**. No deductibles, no functional failure excluded from coverage – **real protection**.
- ☑ **Expert service** by a force of more than **10,000 authorized Sears service technicians**, which means someone you can trust will be working on your product.
- ☑ **Unlimited service calls and nationwide service**, as often as you want us, whenever you want us.
- ☑ **“No-lemon” guarantee** – replacement of your covered product if four or more product failures occur within twelve months.
- ☑ **Product replacement** if your covered product can't be fixed.
- ☑ **Annual Preventive Maintenance Check** at your request – no extra charge.
- ☑ **Fast help by phone** – we call it **Rapid Resolution** – phone support from a Sears representative on all products. Think of us as a “talking owner's manual”.
- ☑ **Power surge protection** against electrical damage due to power fluctuations.
- ☑ **\$250 Food Loss Protection** annually for any food spoilage that is the result of mechanical failure of any covered refrigerator or freezer.
- ☑ **Rental reimbursement** if repair of your covered product takes longer than promised.
- ☑ **10% discount** off the regular price of any non-covered repair service and related installed parts.

Once you purchase the Agreement, a simple phone call is all that it takes for you to schedule service. You can call anytime day or night, or schedule a service appointment online.

The Master Protection Agreement is a risk free purchase. If you cancel for any reason during the product warranty period, we will provide a full refund. Or, a prorated refund anytime after the product warranty period expires. Purchase your Master Protection Agreement today!

Some limitations and exclusions apply. For prices and additional information in the U.S.A. call 1-800-827-6655.

*** Coverage in Canada varies on some items. For full details call Sears Canada at 1-800-361-6665.**

Sears Installation Service

For Sears professional installation of home appliances, garage door openers, water heaters, and other major home items, in the U.S.A. or Canada call **1-800-4-MY-HOME®**.



Installation

This Owner's Guide provides specific operating instructions for your model. Use the freezer only as instructed in this Use & Care Manual. **Before starting the freezer, follow these important first steps.**

LOCATION

- Choose a place that is near a grounded electrical outlet. **Do Not** use an extension cord or an adapter plug.
- For the most efficient operation, the freezer should be located where surrounding temperatures will not drop below 40°F (5°C) or exceed 110°F (43°C).
- Allow the following clearances for ease of installation, proper air circulation, and electrical connections:

Sides	3/8"
Back & Top	1"
- Do Not block the toe grille on the lower front of your freezer. Sufficient air circulation is essential for the proper operation of your freezer.

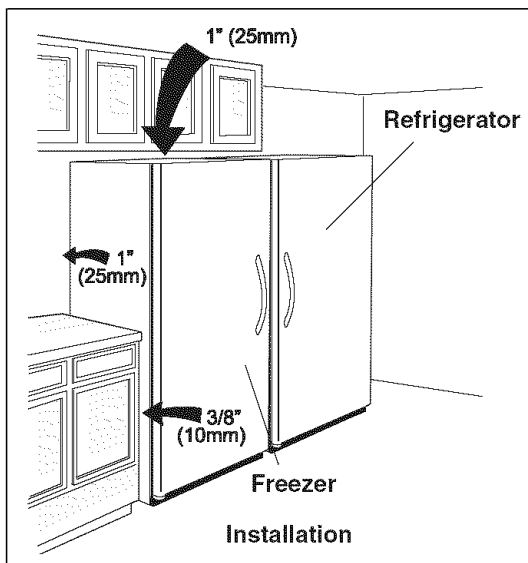

NOTE

The exterior walls of the freezer may become quite warm as the compressor works to transfer heat from the inside. Temperatures as much as 30°F warmer than room temperature can be expected.

DOOR OPENING

NOTE

If your freezer is placed with the door hinge side against a wall, you may have to allow additional space so the door can be opened wider.

LEVELING

The freezer must have all bottom corners resting firmly on a solid floor. The floor must be strong enough to support a fully loaded freezer. **NOTE:** It is **Very Important** for your freezer to be level in order to function properly. If the freezer is not leveled during installation, the door may be misaligned and not close or seal properly, causing cooling, frost, or moisture problems.

To Level Freezer:

After discarding crating screws and wood base, use a carpenter's level to level the freezer from front-to-back. Adjust the plastic leveling feet in front, 1/2 bubble higher, so that the door closes easily when left halfway open.

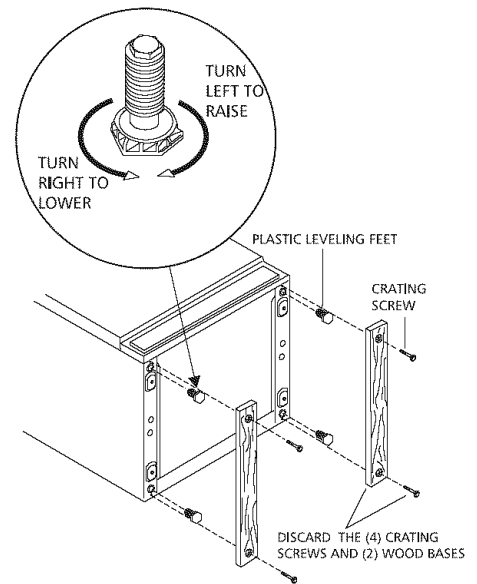

Leveling Instructions for all Refrigerator/Freezer Pair:

- Remove two leg levelers provided in literature bag. While unit is lying on its back for wood skid removal, install both leg levelers in rear of unit.
- Level door of first unit using all four levelers and slide unit into place. Recheck for levelness and adjust if necessary.
- Measure distance from floor to bottom of door on first unit. Adjust and level second unit so door height matches.
- Leg Level Adjustments
 - One full turn of all four leg levelers will raise door 5/32".
 - One full turn of both front leg levelers will raise door 3/16" and tilt top of door back 7/16".
 - One full turn of both rear leg levelers will lower door 1/32" and tilt top of door forward 7/16".
 - One full turn of both side leg levelers will raise door 3/16" and tilt top of door 3/8".
- Slide second unit into place leaving a minimum gap of 3/16" between units for door swing clearance.
- This last step may require at least one extraction of the second unit to properly align units in a "built-in" application.

ENGLISH



Installation (Continued)

CAUTION

To allow door to close and seal properly, do not let food packages extend past the front of the shelves.

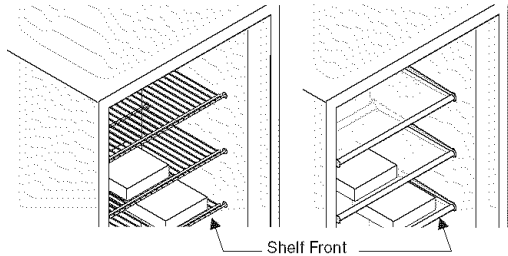

ICE MAKER INSTALLATION

If your freezer has an automatic ice maker, please refer to the two inserts in the bond pack that came with your freezer to correctly hook-up your ice maker:

- 1 Installation Instructions
- 2 Installation - Connecting Ice Maker to Water Supply

DOOR REMOVAL

If door must be removed:

- 1 Gently lay freezer on its back, on a rug or blanket.
- 2 Remove two base screws and base panel.
- 3 Remove bottom hinge screws.
- 4 Remove plastic top hinge cover.
- 5 Remove screws from top hinge.
- 6 Remove top hinge from cabinet.
- 7 Remove door and bottom hinge from cabinet.
- 8 To replace door, reverse the above order and manner of removal. Securely tighten all screws to prevent hinge slippage.



Temperature Control

COOL DOWN PERIOD

- For safe food storage, allow 4 hours for the freezer to cool down completely. The freezer will run continuously for the first several hours. Foods that are already frozen may be placed in the freezer after the first few hours of operation. Unfrozen foods should NOT be loaded into the freezer until the freezer has operated for 4 hours.
- When loading the freezer, freeze only 3 pounds of fresh food per cubic foot of freezer space at one time. Distribute packages to be frozen evenly throughout the freezer. It is not necessary to turn the control knob to a colder setting while freezing food.

TEMPERATURE CONTROL

The temperature control is located inside the freezer compartment. The temperature is factory preset to provide satisfactory food storage temperatures. However, the temperature control is adjustable to provide a range of temperatures for your personal satisfaction. If a colder temperature is desired, turn the temperature control knob toward COLDEST and allow several hours for temperatures to stabilize between adjustments.

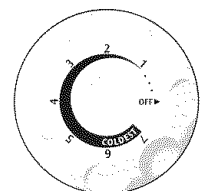

Cold Control



Freezer Features

INTERIOR LIGHT

The light comes on automatically when the door is opened. To replace the light bulb, turn the temperature control to OFF and **unplug the electrical cord**. Replace the old bulb with a bulb of the same wattage.

DRAWER WITH ADJUSTABLE DIVIDERS

The drawer, located at the bottom of the freezer, provides separate storage space for items that are difficult to store on freezer shelves.

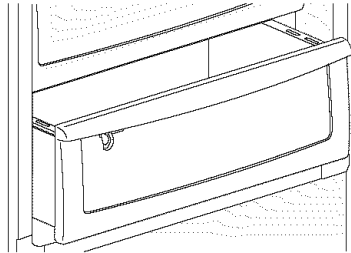

TILT-OUT SHELF

This shelf is located inside on the freezer door and provides additional storage space. To access an item, tilt top of "basket" shelf down.

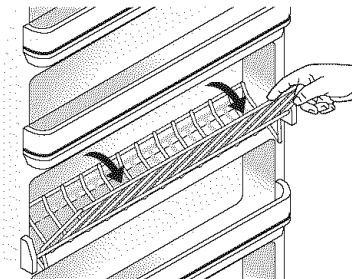

Tilt-Out Shelf

ADJUSTABLE INTERIOR SHELVES

Multi-position adjustable interior shelves can be moved to any position for larger or smaller packages. The shipping spacers that stabilize the shelves for shipping may be removed and discarded.

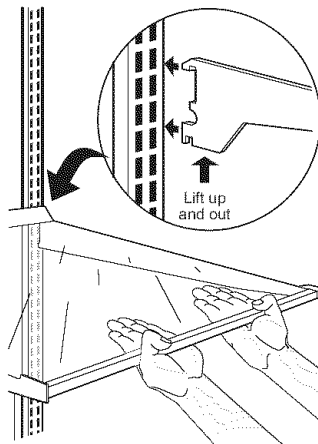

Adjustable Interior Shelves - Upright Models

TO ADJUST CANTILEVER SHELVES

NOTE

Cantilever shelves are supported at the back of the freezer.

- 1 Lift front edge up.
- 2 Pull shelf out.

Replace the shelf by inserting the hooks at rear of the shelf into the wall bracket. Lower the shelf into the desired slots and lock into position.

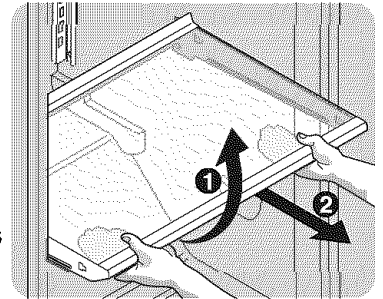

MID LEVEL LIGHT

The light comes on automatically when the door is opened. To replace the light bulb, turn the temperature control to OFF and **unplug the electrical cord**. Remove the lens from the lamp housing by unsnapping it from the lamp housing using your fingers or a screwdriver. Be careful not to break the locking tabs on the lamp housing. Replace the old bulb with a bulb of the same type and wattage. To replace the lens, snap one side of the lens opening to the tab on the lamp housing. Then carefully attach the other side.

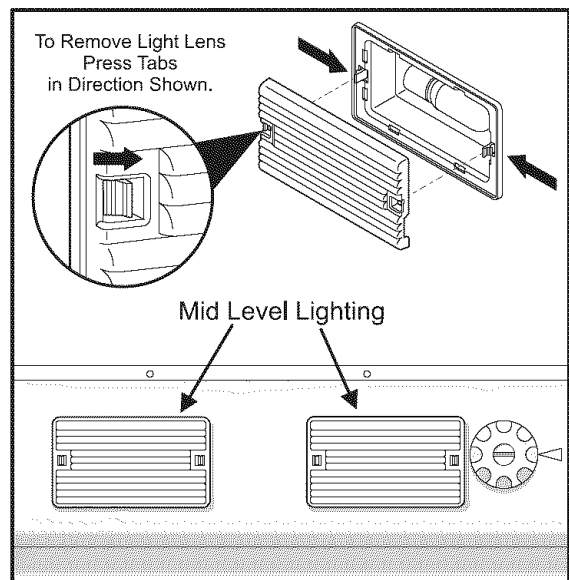

ENGLISH



Energy Saving Tips



- The freezer should be located in the coolest area of the room, away from heat producing appliances or heating ducts, and out of direct sunlight.
- Let hot foods cool to room temperature before placing in the freezer. Overloading the freezer forces the compressor

to run longer. Foods that freeze too slowly may spoil or lose quality.

- Be sure to wrap foods properly, and wipe containers dry before placing them in the freezer. This cuts down on frost build-up inside the freezer.
- Freezer shelves should not be lined with aluminum foil, wax paper, or paper toweling. Liners interfere with cold air circulation, making the freezer less efficient.
- Organize and label food to reduce door openings and extended searches. Remove as many items as needed at one time, and close the door as soon as possible.

VACATION AND MOVING TIPS

Short Vacations:

Leave the freezer operating during vacations of less than three weeks.

Long Vacations:

If the freezer will not be used for several months:

- Remove all food and unplug the power cord.
- Clean and dry the interior thoroughly.
- Leave the freezer door open slightly, blocking it open if necessary, to prevent odor and mold growth.

Moving: When moving the freezer, follow these guidelines to prevent damage:

- Disconnect the power cord plug from the wall outlet.
- Remove foods, then defrost, and clean the freezer.
- Secure all loose items such as base panel, baskets, and shelves by taping them securely in place to prevent damage.
- In the moving vehicle, secure freezer in an upright position to prevent movement. Also protect outside of freezer with a blanket, or similar item.



Power Failure / Freezer Failure

ENGLISH

NOTE

Do not open freezer door unnecessarily if freezer is off for several hours.

If a power failure occurs, frozen foods will stay frozen for at least 24 hours if the freezer is kept closed. If the power failure continues, pack seven or eight pounds of dry ice into the freezer every 24 hours. Look in the Yellow Pages under Dry Ice, Dairies, or Ice Cream Manufacturers for local dry ice suppliers. Always wear gloves and use caution when handling dry ice.

If the freezer has stopped operating, see “Freezer Does Not Run” in the “Before You Call” Section. If you cannot solve the problem, call Sears Service immediately.

If the freezer remains off for several hours, follow the directions above for the use of dry ice during a power failure. If necessary, take the food to a local locker plant until the freezer is ready to operate. Look in the Yellow Pages under Frozen Food Locker Plants.



If your freezer has an automatic ice maker, it will provide a sufficient supply of ice for normal use. During the initial startup of your freezer, however, no ice will be produced during the first 24 hours of operation. Automatic ice makers are also optional accessories that may be installed in some models at any time. Call your local dealer for information.

TURNING YOUR ICE MAKER ON

After the plumbing connections have been completed, the water supply valve must be opened. Place the ice container under the ice maker, pushing it as far back as possible. Lower the wire signal arm to its "down" or ON position. New plumbing connections may cause the first production of ice cubes to be discolored or have an odd flavor. These first cubes should be discarded until the cubes produced are free of discoloration and taste.

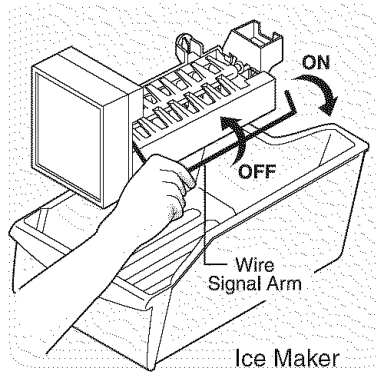

TURNING YOUR ICE MAKER OFF

To stop the ice maker, lift the wire signal arm until it clicks and locks in the "up" or OFF position. The ice maker also turns off automatically when the ice container is full. If your model has an adjustable freezer shelf, place the shelf in the lower position, so that the wire signal arm will hit the ice when the container is full.

IMPORTANT

Check the leveling bracket on the ice maker to ensure the ice maker is level. If the gap between the freezer wall and the ice maker is the same at top and bottom, then the ice maker is level.

Your ice maker is shipped with the wire signal arm in the ON position. To ensure proper function of your ice maker, hook up water supply immediately or turn ice maker OFF by lifting the wire signal arm until it clicks and locks in the UP position.

ICE MAKER TIPS

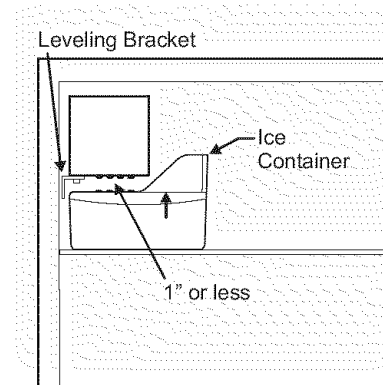

- Ice cubes stored too long may develop an odd flavor. Empty the ice container and ensure that the wire signal arm is in its "down" or ON position. The ice maker will then produce more ice.
- Occasionally shake the ice container to keep ice separated.
- Keep the wire signal arm in its "up" or OFF position until the freezer is connected to the water supply or whenever the water supply is turned off.
- The following sounds are normal when the ice maker is operating:
 - Motor running
 - Ice loosening from tray
 - Ice dropping into ice container
 - Running water
 - Water valve opening or closing
- Wash the ice container in warm water with mild detergent. Rinse well and dry.

CAUTION

Do Not place the ice container in your dishwasher.

- Stop the ice maker when cleaning the freezer and during vacations.
- If the ice maker will be turned off for a long period of time, turn the water supply valve to the closed position.



Care and Cleaning

Keep your freezer clean to prevent odor build-up. Wipe up any spills immediately and clean at least twice a year. **Never** use metallic scouring pads, brushes, abrasive cleaners or strong alkaline solutions on any surface. **Do not** wash any removable parts in a dishwasher. **Always unplug the electrical power cord from the wall outlet before cleaning.**

CAUTION

- When moving the freezer, pull straight out. Do not shift the freezer from side to side as this may tear or gouge the floor covering.
- Damp objects stick to cold metal surfaces. Do not touch interior metal surfaces with wet or damp hands.

NOTE

- Turning the freezer temperature control to “OFF” turns off the compressor, but does not disconnect electrical power to the light bulb or other electrical components. To turn off power to your freezer, you must unplug the power cord from the wall outlet.
- Do not use razor blades or other sharp instruments which can scratch the appliance surface when removing adhesive labels. Any glue left from tape or labels can be removed with a mixture of warm water and mild detergent, or, touch the glue residue with the sticky side of tape you have already removed. Do not remove the serial plate.

Care & Cleaning Chart

Part	What To Use	Tips and Precautions
Interior/Door Liner	<ul style="list-style-type: none"> • Soap and water • Baking soda and water 	Use 2 tablespoons of baking soda in 1 quart of warm water. Be sure to wring excess water out of sponge or cloth before cleaning around controls, light bulb or any electrical part.
Door Gaskets	<ul style="list-style-type: none"> • Soap and water 	Wipe gaskets with a clean soft cloth.
Drawers/Bins	<ul style="list-style-type: none"> • Soap and water 	Do not wash any removable items (bins, drawers, etc.) in dishwasher.
Glass Shelves	<ul style="list-style-type: none"> • Soap and water • Glass cleaner • Mild liquid sprays 	Allow glass to warm to room temperature before immersing in warm water.
Exterior and Handles	<ul style="list-style-type: none"> • Soap and water • Non Abrasive Glass Cleaner 	Do not use commercial household cleaners, ammonia, or alcohol to clean handles. Use a soft cloth to clean smooth handles. Do Not use a dry cloth to clean smooth doors.
Exterior and Handles (Stainless Steel Models Only)	<ul style="list-style-type: none"> • Soap and water • Ammonia • Stainless Steel Cleaners 	Clean stainless steel front and handles with soapy water and a dishcloth. Rinse with clean water and a soft cloth. Wipe stubborn spots with an ammonia-soaked paper towel, and rinse. Use a non-abrasive stainless steel cleaner. These cleaners can be purchased at most home improvement or major department stores. Always follow manufacturer's instructions. NOTE: Always clean, wipe and dry with the grain to prevent cross-grain scratching. Wash the rest of the cabinet with warm water and mild liquid detergent. Rinse well, and wipe dry with a clean soft cloth.



Before You Call

TROUBLESHOOTING GUIDE

Before calling for service, review this list. It may save you time and expense. This list includes common occurrences that are not the result of defective workmanship or materials in this appliance.

Problem	Cause	Correction
Freezer Does Not Run		
Freezer does not run.	<ul style="list-style-type: none"> Freezer is plugged into a circuit that has a ground fault interrupt. Temperature control is in the OFF position. Freezer may not be plugged in, or plug may be loose. House fuse blown or tripped circuit breaker. Power outage. 	<ul style="list-style-type: none"> Use another circuit. If you are unsure about the outlet, have it checked by a certified technician. See "Temperature Control" Section. Ensure plug is tightly pushed into outlet Check/replace fuse with a 15 amp time-delay fuse. Reset circuit breaker. Check house lights. Call local Electric Company.
Freezer runs too much or too long.	<ul style="list-style-type: none"> Room or outside weather is hot. Freezer has recently been disconnected for a period of time. Large amounts of warm or hot food have been stored recently. Doors are opened too frequently or too long. Freezer door may be slightly open. Temperature Control is set too low. Freezer gasket is dirty, worn, cracked, or poorly fitted. 	<ul style="list-style-type: none"> It's normal for the freezer to work harder under these conditions. It takes 4 hours for the freezer to cool down completely. Warm food will cause freezer to run more until the desired temperature is reached. Warm air entering the freezer causes it to run more. Open doors less often. See "Door Problems" in the "Before You Call" Section. Turn control knob to a warmer setting. Allow several hours for the temperature to stabilize. Clean or change gasket. Leaks in the door seal will cause freezer to run longer in order to maintain desired temperature.
Interior freezer temperature is too cold.	<ul style="list-style-type: none"> Temperature control is set too low. 	<ul style="list-style-type: none"> Turn the control to a warmer setting. Allow several hours for the temperature to stabilize.
Interior freezer temperature is too warm.	<ul style="list-style-type: none"> Temperature control is set too warm. Door is kept open too long or is opened too frequently. Door may not be sealing properly. Large amounts of warm or hot food may have been stored recently. Freezer has recently been disconnected for a period of time. 	<ul style="list-style-type: none"> Turn control to a colder setting. Allow several hours for the temperature to stabilize. Warm air enters the freezer every time the door is opened. Open the door less often. See "Door Problems" in the "Before You Call" Section. Wait until the freezer has had a chance to reach its selected temperature. Freezer requires 4 hours to cool down completely.
Freezer external surface temperature is warm.	<ul style="list-style-type: none"> The external freezer walls can be as much as 30°F warmer than room temperature. 	<ul style="list-style-type: none"> This is normal while the compressor works to transfer heat from inside the freezer cabinet.



Before You Call

Problem	Cause	Correction
Sound and Noise		
Louder sound levels whenever freezer is on.	<ul style="list-style-type: none"> Modern freezers have increased storage capacity and more stable temperatures. They require a high efficiency compressor. 	<ul style="list-style-type: none"> This is normal. When the surrounding noise level is low, you might hear the compressor running while it cools the interior.
Longer sound levels when compressor comes on.	<ul style="list-style-type: none"> Freezer operates at higher pressures during the start of the ON cycle. 	<ul style="list-style-type: none"> This is normal. Sound will level off or disappear as freezer continues to run.
Popping or cracking sound when compressor comes on.	<ul style="list-style-type: none"> Metal parts undergo expansion and contraction, as in hot water pipes. 	<ul style="list-style-type: none"> This is normal. Sound will level off or disappear as freezer continues to run.
Bubbling or gurgling sound, like water boiling.	<ul style="list-style-type: none"> Refrigerant (used to cool freezer) is circulating throughout the system. 	<ul style="list-style-type: none"> This is normal.
Vibrating or rattling noise.	<ul style="list-style-type: none"> Freezer is not level. It rocks on the floor when it is moved slightly. Floor is uneven or weak. Freezer rocks on floor when it is moved slightly. Freezer is touching the wall. 	<ul style="list-style-type: none"> Level the unit. Refer to "Leveling" in the "Installation" Section. Ensure floor can adequately support freezer. Level the freezer by putting wood or metal shims under part of the freezer. Relevel the freezer or move freezer slightly. Refer to "Leveling" in the "Installation" Section.
Water/Moisture/Frost Inside Freezer		
Moisture forms on inside freezer walls.	<ul style="list-style-type: none"> Weather is hot and humid, which increases internal rate of frost build-up. Door may not be seating properly. Door is kept open too long, or is opened too frequently. 	<ul style="list-style-type: none"> This is normal. See "Door Problems" in the "Before You Call" Section. Open the door less often.
Water/Moisture/Frost Outside Freezer		
Moisture forms on outside of freezer.	<ul style="list-style-type: none"> Door may not be sealing properly, causing the cold air from inside the freezer to meet warm moist air from outside. 	<ul style="list-style-type: none"> See "Door Problems" in the "Before You Call" Section.
Odor in Freezer		
Odors in freezer.	<ul style="list-style-type: none"> Interior needs to be cleaned. Foods with strong odors are in the freezer. 	<ul style="list-style-type: none"> Clean interior with sponge, warm water, and baking soda. Cover the food tightly.



Before You Call

Problem	Cause	Correction
Door Problems		
Door will not close.	<ul style="list-style-type: none"> Freezer is not level. It rocks on the floor when it is moved slightly. Floor is uneven or weak. Freezer rocks on floor when it is moved slightly. 	<ul style="list-style-type: none"> This condition can force the cabinet out of square and misalign the door. Refer to "Leveling" in the "Installation" Section. Level the floor by using wood or metal shims under the freezer or brace floor supporting the freezer.
Light Bulb Is Not On		
Light bulb is not on.	<ul style="list-style-type: none"> Light bulb is burned out. No electric current is reaching the freezer. 	<ul style="list-style-type: none"> Follow directions under "Interior Light" or "Mid Level Light" in the "Freezer Features" Section. See "Freezer Does Not Run" in the "Before You Call" Section.
Automatic Ice Maker		
Automatic ice maker not working. (some models)	<ul style="list-style-type: none"> Ice maker is not working. 	<ul style="list-style-type: none"> Ensure the wire signal arm is not in the UP position. Water supply is turned off. Water pressure is too low. The freezer is not cold enough.