

Operating Instructions

Blu-ray Disc Home Theater Sound System

Model No. **SC-BT100**

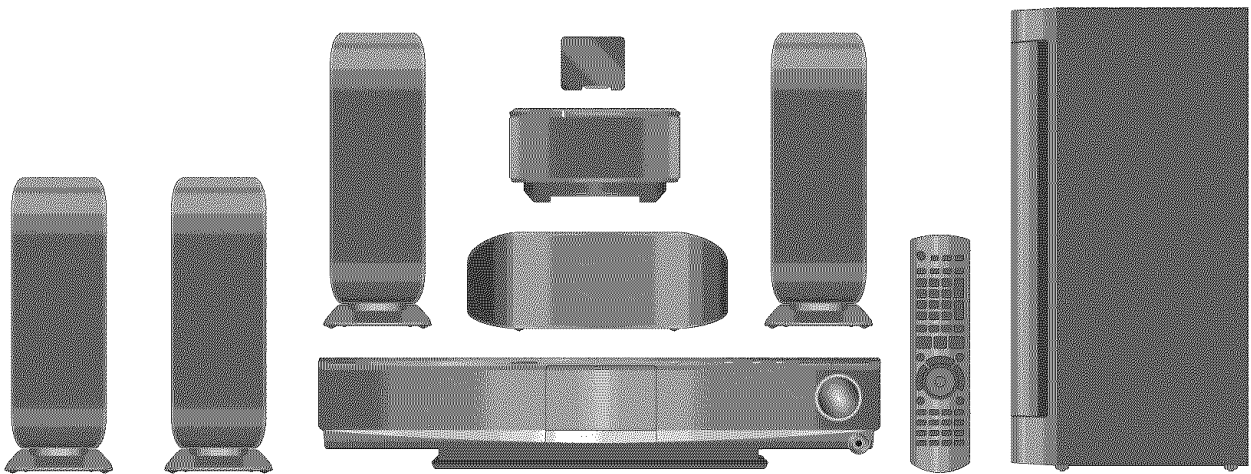

P4 Quick Start Guide

Dear customer

Thank you for purchasing this product.
For optimum performance and safety, please read these instructions carefully.

Before connecting, operating or adjusting this product, please read the instructions completely. Please keep this manual for future reference.



BD-Video



Region management information

BD-Video

This unit plays BD-Video marked with labels containing the region code A.

Example:

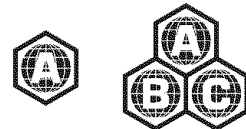

DVD-Video

This unit plays DVD-Video marked with labels containing the region number "1" or "ALL".

Example:



As an ENERGY STAR® Partner,*
Panasonic has determined that
this product meets the ENERGY STAR®
guidelines for energy efficiency.

If you have any questions contact

U.S.A.: 1-800-211-PANA(7262)
Canada: 1-800-561-5505

U.S.A.: The warranty can be found on page 46.
Canada: The warranty can be found on page 47.

P27 Enjoying surround sound

Operations in these instructions are described mainly with the remote control, but you can perform the operations on the main unit if the controls are the same.







System	SC-BT100
Main unit	SA-BT100
Front speakers	SB-HF100
Center speaker	SB-HC100
Surround speakers	SB-HS100
Subwoofer	SB-HW560
Digital transmitter	SH-FX67T
Wireless system	SE-FX67

Accessory information

 Please check and identify the supplied accessories. Use numbers indicated in parentheses when asking for replacement parts. (Product numbers correct as of February 2008. These may be subject to change.)

Only for U.S.A.: To order accessories, refer to "Accessory Purchases" on page 46.

Only for Canada: To order accessories, call the dealer from whom you have made your purchase.

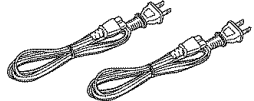
- | | | | |
|---|---|--|--|
| <input type="checkbox"/> | <input type="checkbox"/> | <input type="checkbox"/> | <input type="checkbox"/> |
|  |  |  |  |
| 1 Remote control
(N2QAKB000061) | 2 Remote control batteries | 1 AM loop antenna
(N1DAAA00002) | 1 FM indoor antenna
(RSA0007-M) |
| <input type="checkbox"/> | <input type="checkbox"/> | <input type="checkbox"/> | <input type="checkbox"/> |
|  |  |  |  |
| 1 Video cable
(K2KA2BA00001) | 1 Sheet of speaker cable stickers | 5 Speaker cables
[REEX0859-L (White)]
[REEX0867A-L (Red)]
[REEX0858-L (Green)]
[REEX0860A-L (Blue)]
[REEX0868A-L (Gray)] | 2 AC power supply cords
(K2CB2CB00021)
● For use with this unit only. Do not use them with other equipment. Also, do not use cords for other equipment with this unit or wireless system. |

The enclosed Canadian French label sheet corresponds to the English display on the front and back side of the unit.

WARNING:

TO REDUCE THE RISK OF FIRE, ELECTRIC SHOCK OR PRODUCT DAMAGE,

- DO NOT EXPOSE THIS APPARATUS TO RAIN, MOISTURE, DRIPPING OR SPLASHING AND THAT NO OBJECTS FILLED WITH LIQUIDS, SUCH AS VASES, SHALL BE PLACED ON THE APPARATUS.
- USE ONLY THE RECOMMENDED ACCESSORIES.
- DO NOT REMOVE THE COVER (OR BACK); THERE ARE NO USER SERVICEABLE PARTS INSIDE. REFER SERVICING TO QUALIFIED SERVICE PERSONNEL.

CAUTION!

THIS PRODUCT UTILIZES A LASER. USE OF CONTROLS OR ADJUSTMENTS OR PERFORMANCE OF PROCEDURES OTHER THAN THOSE SPECIFIED HEREIN MAY RESULT IN HAZARDOUS RADIATION EXPOSURE. DO NOT OPEN COVERS AND DO NOT REPAIR YOURSELF. REFER SERVICING TO QUALIFIED PERSONNEL.

(For wireless system)

The following mark and symbols are located on bottom of the unit.

	CAUTION RISK OF ELECTRIC SHOCK DO NOT OPEN	
<p>CAUTION: TO REDUCE THE RISK OF ELECTRIC SHOCK, DO NOT REMOVE SCREWS. NO USER-SERVICEABLE PARTS INSIDE. REFER SERVICING TO QUALIFIED SERVICE PERSONNEL.</p>		

 The lightning flash with arrowhead symbol, within an equilateral triangle, is intended to alert the user to the presence of uninsulated "dangerous voltage" within the product's enclosure that may be of sufficient magnitude to constitute a risk of electric shock to persons.

 The exclamation point within an equilateral triangle is intended to alert the user to the presence of important operating and maintenance (servicing) instructions in the literature accompanying the appliance.

THE FOLLOWING APPLIES ONLY IN THE U.S.A.

FCC Note:

This equipment has been tested and found to comply with the limits for a Class B digital device, pursuant to Part 15 of the FCC Rules. These limits are designed to provide reasonable protection against harmful interference in a residential installation. This equipment generates, uses and can radiate radio frequency energy and, if not installed and used in accordance with the instructions, may cause harmful interference to radio communications. However, there is no guarantee that interference will not occur in a particular installation. If this equipment does cause harmful interference to radio or television reception, which can be determined by turning the equipment off and on, the user is encouraged to try to correct the interference by one or more of the following measures:

- Reorient or relocate the receiving antenna.
- Increase the separation between the equipment and receiver.
- Connect the equipment into an outlet on a circuit different from that to which the receiver is connected.
- Consult the dealer or an experienced radio/TV technician for help.

FCC caution: To maintain compliance with FCC regulations, shielded interface cables must be used with this equipment. Operation with non-approved equipment or unshielded cables may result in interference to radio and TV reception. Any changes or modifications not approved by the party responsible for compliance could void the user's authority to operate this equipment.

This device complies with Part 15 of the FCC Rules.

Operation is subject to the following two conditions:

- (1) This device may not cause harmful interference, and
- (2) this device must accept any interference received, including interference that may cause undesired operation.

Responsible Party:

Panasonic Corporation of North America
One Panasonic Way
Secaucus, NJ 07094

Support Contact:

Panasonic Consumer Electronics Company
Telephone No.: 1-800-211-PANA (7262)

 **WARNING:**

To satisfy FCC RF exposure requirements for mobile transmitting devices, a separation distance of 20 cm or more should be maintained between the antenna of this device and persons during device operation. To ensure compliance, operations at closer than this distance is not recommended. The antenna used for this transmitter must not be co-located in conjunction with any other antenna or transmitter.

THE FOLLOWING APPLIES ONLY IN CANADA.

(For wireless system)

This Class B digital apparatus complies with Canadian ICES-003.

This device complies with RSS-210 of the IC Rules.

Operation is subject to the following two conditions:

- (1) This device may not cause harmful interference,
- (2) This device must accept any interference received, including interference that may cause undesired operation of the device.

Table of contents

Getting started

Accessory information	2
Preparing the remote control.....	3
IMPORTANT SAFETY INSTRUCTIONS.....	3

Quick Start Guide

STEP 1 Positioning	4
STEP 2 Basic connections	6
STEP 3 Setting up the unit	9

Control reference guide.....	10
Disc and card information.....	12

Basic operations

Basic play (Playing video contents).....	14
Enjoying TV with this unit's speakers.....	17
Enjoying the FM/AM radio	18
Playing music	19
Playing an iPod on this unit.....	20

Advanced operations

Playing still pictures	22
Different kinds of playback for BD-Video	24
Showing FUNCTIONS menu.....	25
Changing audio quality/sound field	26
Enjoying surround sound	27
Linked operations with the TV (VIERA Link™ "HDAVI Control™").....	28
Changing settings with the on-screen menu ...	30
Changing settings with the setup menu	32

Reference

Optional connections and settings	35
Frequently asked questions.....	37
Messages	38
Troubleshooting guide	39
Disc and card handling.....	42
Maintenance	42
Glossary	43
Specifications.....	44
Limited Warranty (ONLY FOR U.S.A.)	46
Limited Warranty (ONLY FOR CANADA)	47
Product Service.....	47
Index.....	Back cover

Preparing the remote control

Batteries

Insert so the poles (+ and -) match those in the remote control. When closing the lid, insert it from the - (minus) side.

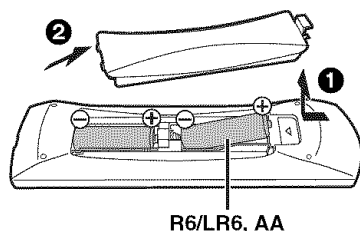

- Do not use rechargeable type batteries.
- Do not mix old and new batteries.
- Do not use different types at the same time.
- Do not heat or expose to flame.
- Do not leave the battery(ies) in an automobile exposed to direct sunlight for a long period of time with doors and windows closed.
- Do not take apart or short circuit.
- Do not attempt to recharge alkaline or manganese batteries.
- Do not use batteries if the covering has been peeled off.

Mishandling of batteries can cause electrolyte leakage which can damage items the fluid contacts and may cause a fire. Remove batteries if the remote control is not going to be used for a long period of time. Store in a cool, dark place.

Use

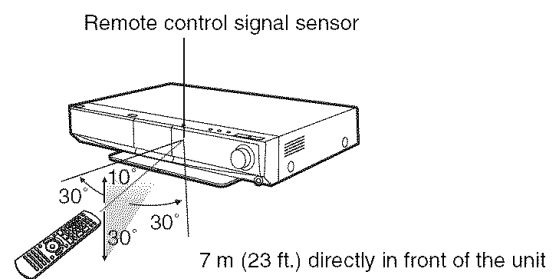

If you cannot operate the unit using the remote control after changing the batteries, please re-enter the codes (⇒ 42).

IMPORTANT SAFETY INSTRUCTIONS

Read these operating instructions carefully before using the unit. Follow the safety instructions on the unit and the applicable safety instructions listed below. Keep these operating instructions handy for future reference.

- 1) Read these instructions.
- 2) Keep these instructions.
- 3) Heed all warnings.
- 4) Follow all instructions.
- 5) Do not use this apparatus near water.
- 6) Clean only with dry cloth.
- 7) Do not block any ventilation openings. Install in accordance with the manufacturer's instructions.
- 8) Do not install near any heat sources such as radiators, heat registers, stoves, or other apparatus (including amplifiers) that produce heat.
- 9) Do not defeat the safety purpose of the polarized or grounding-type plug. A polarized plug has two blades with one wider than the other. A grounding-type plug has two blades and a third grounding prong. The wide blade or the third prong are provided for your safety. If the provided plug does not fit into your outlet, consult an electrician for replacement of the obsolete outlet.
- 10) Protect the power cord from being walked on or pinched particularly at plugs, convenience receptacles, and the point where they exit from the apparatus.
- 11) Only use attachments/accessories specified by the manufacturer.
- 12) Use only with the cart, stand, tripod, bracket, or table specified by the manufacturer, or sold with the apparatus. When a cart is used, use caution when moving the cart/apparatus combination to avoid injury from tip-over.
- 13) Unplug this apparatus during lightning storms or when unused for long periods of time.
- 14) Refer all servicing to qualified service personnel. Servicing is required when the apparatus has been damaged in any way, such as power-supply cord or plug is damaged, liquid has been spilled or objects have fallen into the apparatus, the apparatus has been exposed to rain or moisture, does not operate normally, or has been dropped.



STEP 1 Positioning

Caution

- The main unit and supplied speakers are to be used only as indicated in this setup. Failure to do so may lead to damage to the amplifier and/or the speakers, and may result in the risk of fire. Consult a qualified service person if damage has occurred or if you experience a sudden change in performance.
- Do not attempt to attach these speakers to walls using methods other than those described in this manual.

How you set up your speakers can affect the bass and the sound field. Note the following points:

- Place speakers on flat secure bases.
- Placing speakers too close to floors, walls, and corners can result in excessive bass. Cover walls and windows with thick curtains.

Note
Keep your speakers at least 10 mm (13/32") away from the system for proper ventilation.

Setup example
Place the front, center, and surround speakers at approximately the same distance from the seating position. The angles in the diagram are approximate.

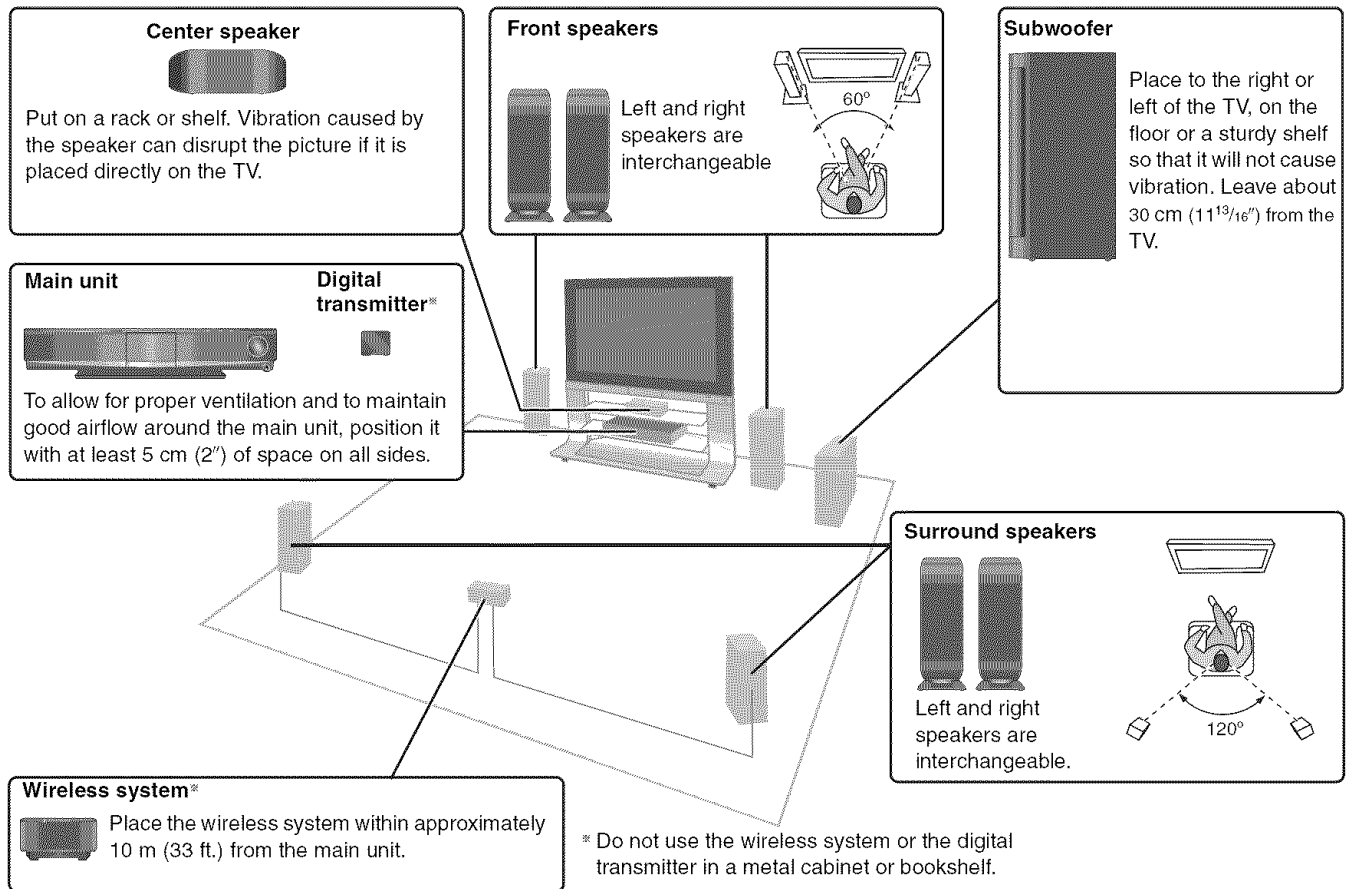

Do not use a front speaker as a surround speaker or vice versa. Verify the type of speaker with the label on the rear of the speaker.

To avoid interference, maintain the following distances between the wireless system and other electronic devices that use the same radio frequency (2.4 GHz band).

The wireless system will automatically seek a clear channel if any of these other devices interfere with its communication. When this happens, the wireless link indicator ("W2S" or "W4S") flashes on the main unit, and there is a brief interruption in audio coming from the surround speakers.

This is the normal operation of the product working to assure the best possible performance of your home theater system.

If the interference persists, try moving the other devices to another location outside the range of the wireless system or move the wireless system nearer to the main unit.

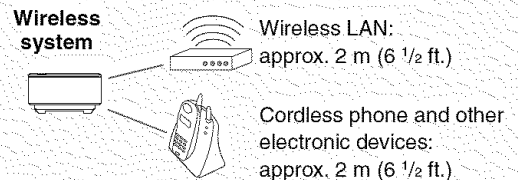

Enjoying 7.1-channel surround sound

Optional Panasonic wireless accessory SH-FX67/Optional Panasonic speaker system SB-HS100A

You can enjoy 7.1ch surround sound when you use the optional Panasonic wireless system SH-FX67 and speaker system SB-HS100A. Refer to the relevant operating instructions for details.

- You can also enjoy 7.1ch surround sound by connecting an amplifier using audio cable via the SURROUND and SURROUND BACK terminals on the back of the main unit (⇒ 36).
- System speaker settings will need to be changed in order to enjoy 7.1ch surround sound (⇒ 34).

■ Notes on speaker use

● Use only supplied speakers

Using other speakers can damage the unit, and sound quality will be negatively affected.

- You can damage your speakers and shorten their useful life if you play sound at high levels over extended periods.
- Reduce the volume in the following cases to avoid damage:
 - When playing distorted sound.
 - When the speakers are reverberating due to a record player, noise from FM broadcasts, or continuous signals from an oscillator, test disc, or electronic instrument.
 - When adjusting the sound quality.
 - When turning the unit on or off.

■ If irregular coloring occurs on your TV

The front and center speakers are designed to be used close to a TV, but the picture may be affected with some TVs and setup combinations.

If this occurs, turn the TV off for about 30 minutes.

The demagnetizing function of the TV should correct the problem. If it persists, move the speakers further away from the TV.

■ Caution

Do not touch the front netted area of the speakers. Hold by the sides. e.g., Center speaker

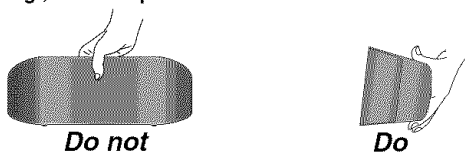

Do not

Do

Speaker installation options

Attaching to a wall

You can attach all of the speakers (except subwoofer) to a wall.

- The wall or pillar on which the speakers are to be attached should be capable of supporting 10 kg (22 lbs) per screw. Consult a qualified building contractor when attaching the speakers to a wall. Improper attachment may result in damage to the wall and speakers.

① Detach stand (Front/Surround speakers).

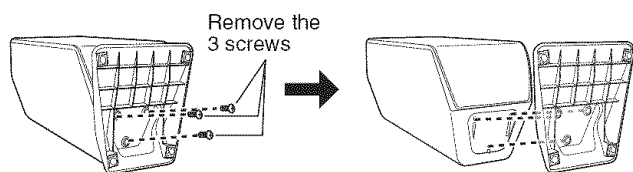

Remove the 3 screws

② Drive a screw (not included) into the wall.

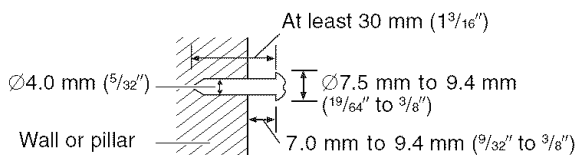

● Center/Front/Surround speaker

Ensure that the screw is positioned at least 70 mm (2 3/4") away from the ceiling.

● Center speaker

Ensure that the screw is positioned at least 100 mm (3 15/16") away from the wall.

Fixing the position for the center speaker screws.

- ① Drive in a screw 50.5 mm (2") left of the right side of the center speaker as seen directly from the front.
- ② Drive another screw 160 mm (6 5/16") left of the first screw.

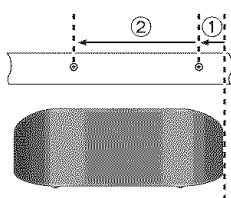

③ Fit the speaker securely onto the screw(s) with the hole(s).

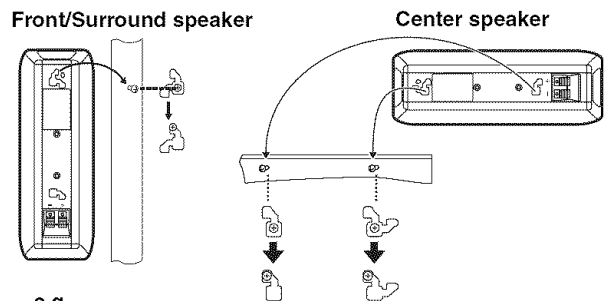

Front/Surround speaker

Center speaker

e.g.,

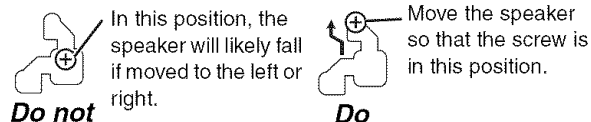

Do not

Do

In this position, the speaker will likely fall if moved to the left or right.

Move the speaker so that the screw is in this position.

Fitting speaker stands (not included)

(Except subwoofer)

Ensure the stands meet these conditions before purchasing them. Note the diameter and length of the screws and the distance between screws as shown in the diagram.

- The stands must be able to support over 10 kg (22 lbs).
- The stands must be stable even if the speakers are in a high position.

e.g., Center speaker

Metal screw holes

For attaching to speaker stands

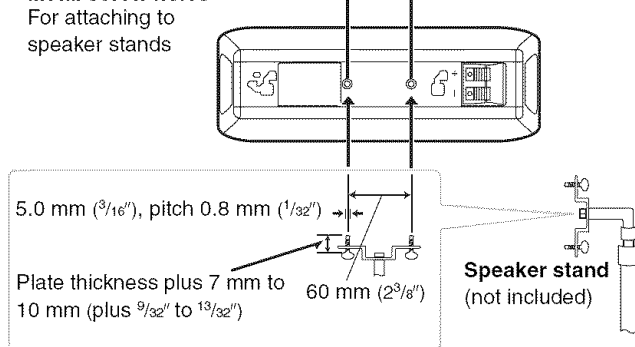

5.0 mm (3/16"), pitch 0.8 mm (1/32")

Plate thickness plus 7 mm to 10 mm (plus 9/32" to 13/32")

60 mm (2 3/8")

Speaker stand (not included)

Prevent the speakers from falling

e.g., Front speaker

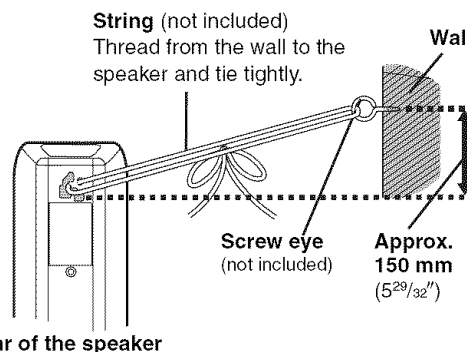

String (not included)
Thread from the wall to the speaker and tie tightly.

Wall

Screw eye (not included)

Approx. 150 mm (5 29/32")

Rear of the speaker

- You will need to obtain the appropriate screw eyes to match the walls and pillars to which they are going to be fastened.
- Consult a qualified housing contractor concerning the appropriate procedure when attaching to a concrete wall or a surface that may not have strong enough support. Improper attachment may result in damage to the wall or speakers.

STEP 2 Basic connections

- Do not place the unit on amplifiers or equipment that may become hot. The heat can damage the unit.
- Turn off all equipment before connection and read the appropriate operating instructions.

Speaker cables and transmitter connection

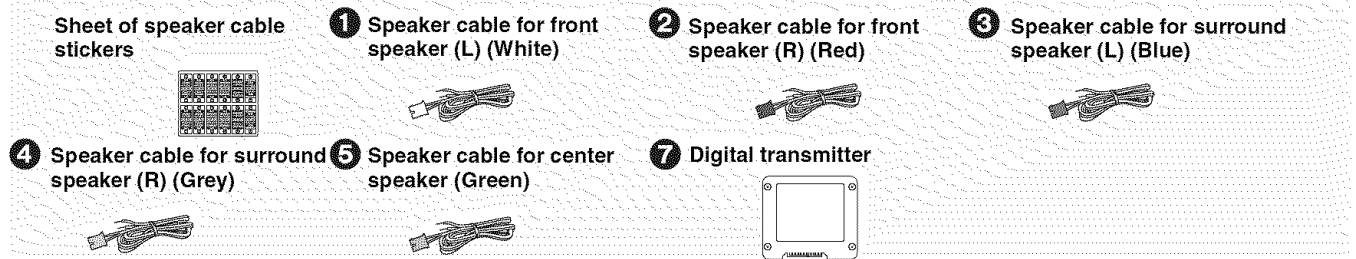

Preparation

- Attach the speaker cable stickers to make connection easier.

e.g., Center speaker

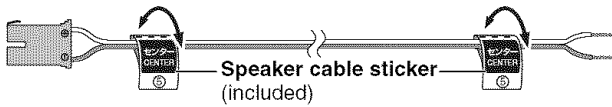

- Set the surround selector at the rear of the wireless system to its center.

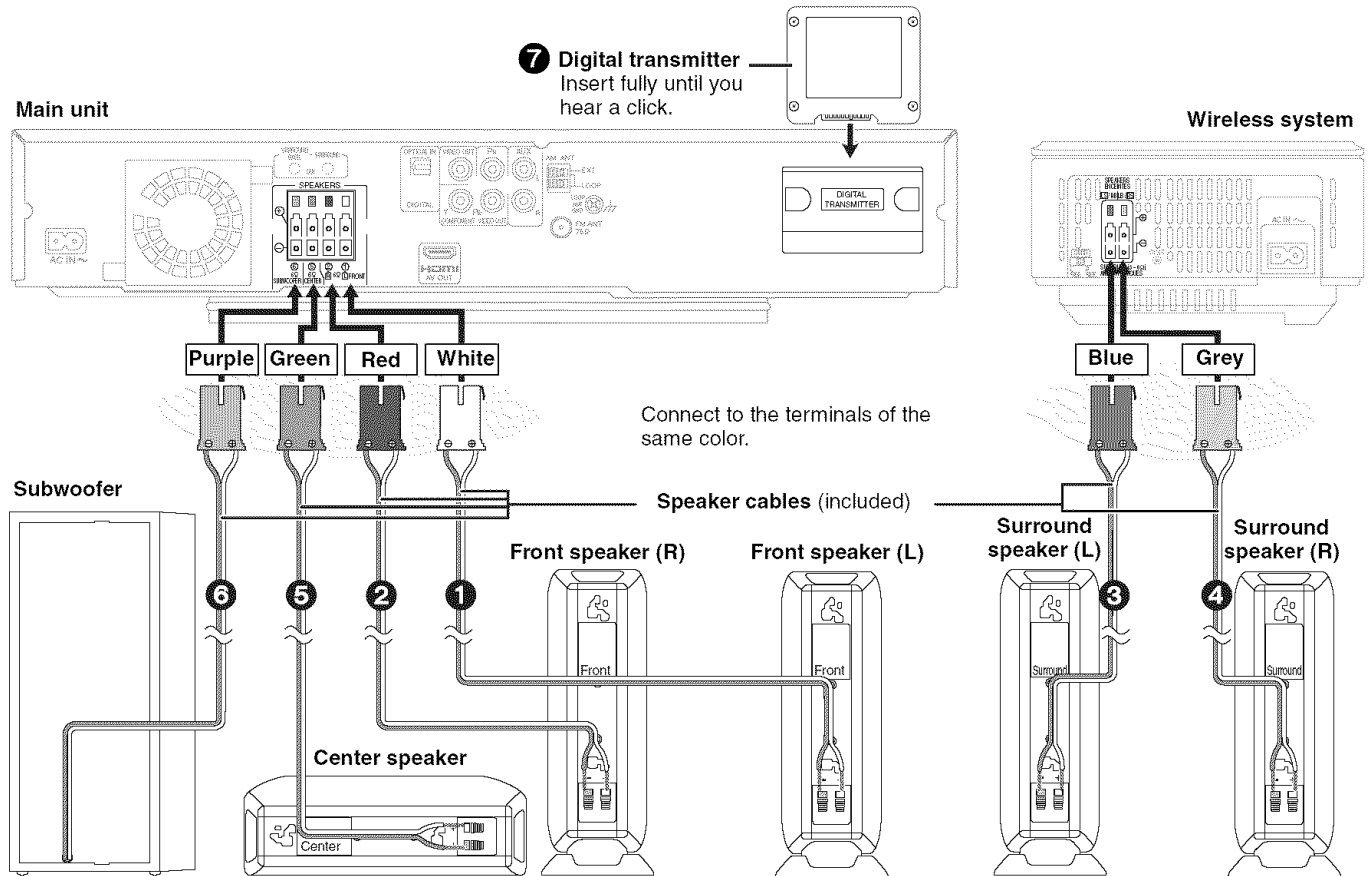
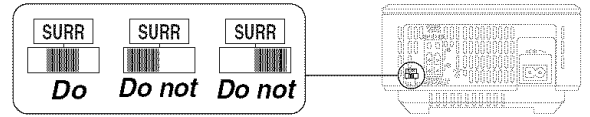

- NOTE**
- Do not use a front speaker as a surround speaker or vice versa. Verify the type of speaker with the label on the rear of the speaker.
 - Do not insert or remove the digital transmitter while the main unit is on.
 - Insert the wires fully.

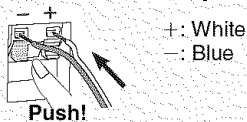

- Be careful not to cross (short-circuit) or reverse the polarity of the speaker wires as doing so may damage the speakers.

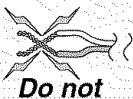

Connection to a TV

• Do not connect through the video cassette recorder. Due to copy guard protection, the picture may not display properly.

With an HDMI cable

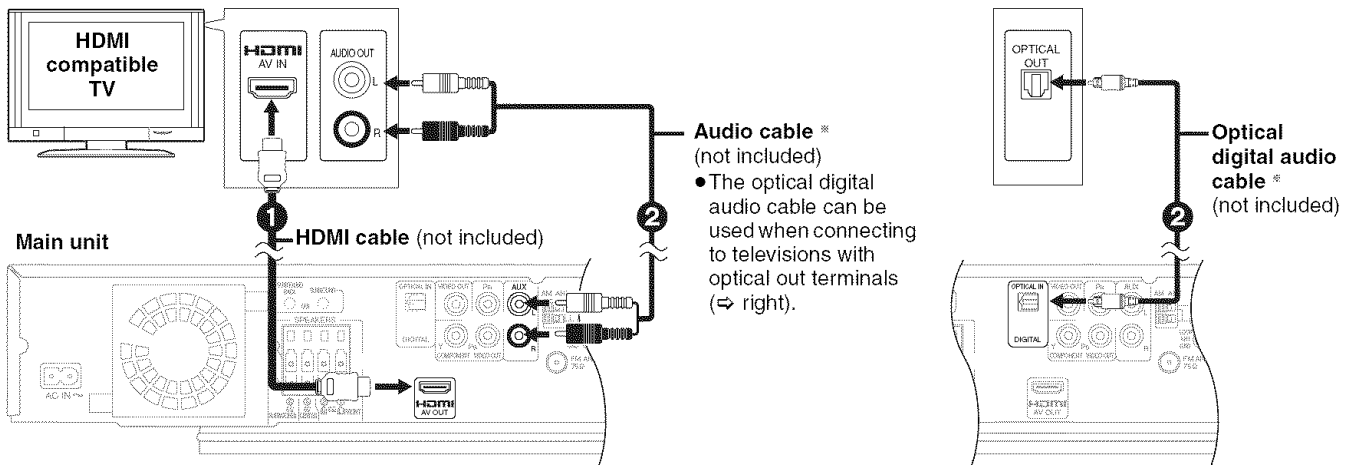

Please use High Speed HDMI cables that have the HDMI logo (as shown on the cover).

It is recommended that you use Panasonic's HDMI cable.

Recommended part number:

NOTE

RP-CDHG10 (1.0 m/3.3 ft.), RP-CDHG15 (1.5 m/4.9 ft.), RP-CDHG20 (2.0 m/6.6 ft.), RP-CDHG30 (3.0 m/9.8 ft.), RP-CDHG50 (5.0 m/16.4 ft.), etc.

NECESSARY SETTINGS

"HDMI Video Mode" : "On"/"HDMI Audio Output" : "Off" (⇒ 33)

With this connection, you can use VIERA Link "HDAVI Control" (⇒ 28).

*These audio connections will enable you to play audio from your television through your home theater system (⇒ 17).

With Video cable

1 Video cable

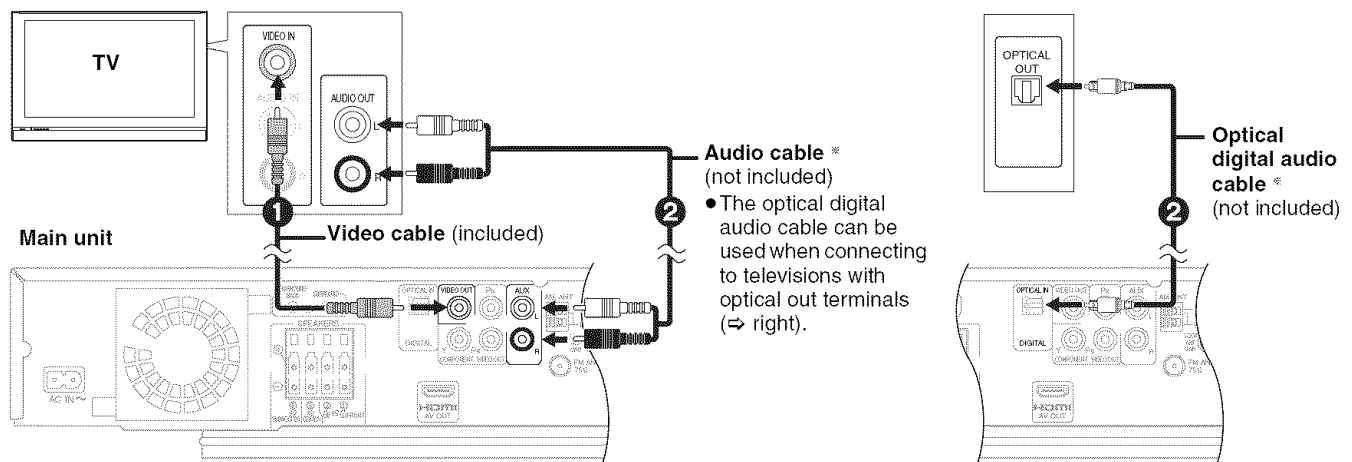

Optional connections

NOTE

- For those who want to enjoy higher picture quality and have a TV equipped with an HDMI terminal (⇒ above)
- For those who want to enjoy higher picture quality and have a TV equipped with a COMPONENT VIDEO IN terminal (⇒ 35)
- For those who have a Set Top Box (Satellite receiver, Cable box, etc) or video cassette recorder (⇒ 35)

*These audio connections will enable you to play audio from your television through your home theater system (⇒ 17).

STEP 2 Basic connections

Radio antenna connections

1 FM Indoor antenna

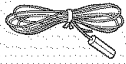

2 AM loop antenna

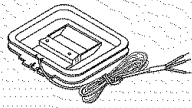

FM indoor antenna (included)

Affix this end of the antenna where reception is best.

AM loop antenna (included)

Stand the antenna up on its base. Place the antenna where reception is best.

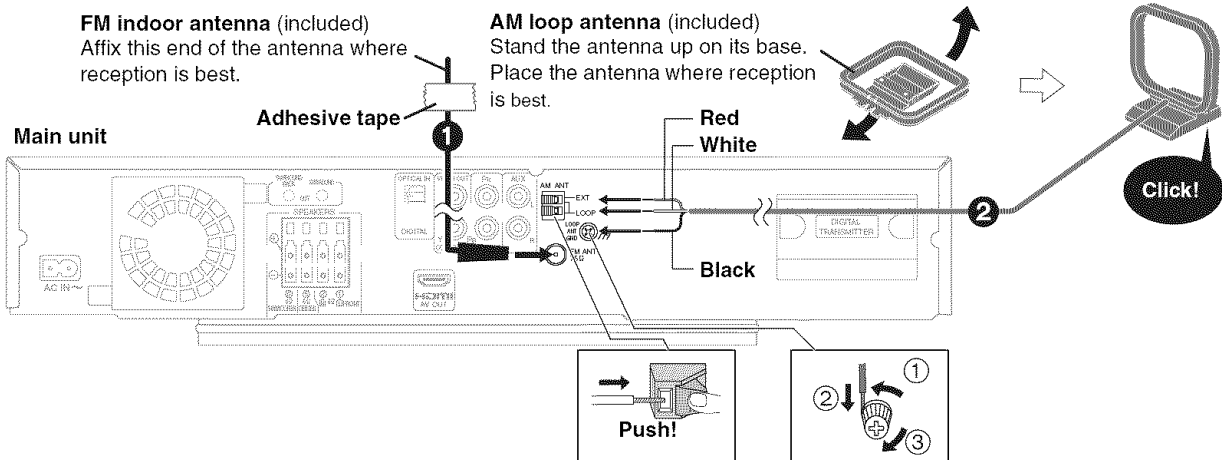

- Keep loose antenna cables away from other wires and cables.

Optional connections

NOTE • Using FM/AM outdoor antenna (optional) (⇒ 36).

AC power supply cord connections

1 AC power supply cord

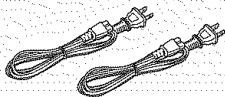

Main unit

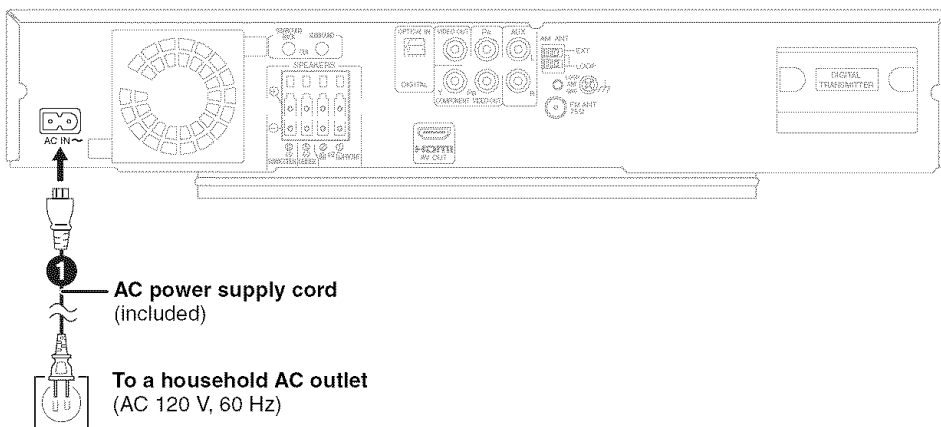

Wireless system

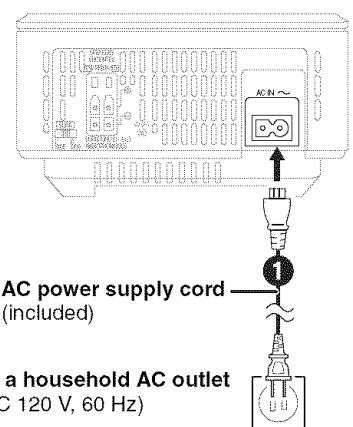

Power consumption

The main unit and the wireless system consume a small amount of power when they are turned off (Main unit: approx. 0.3 W, wireless system: approx. 0.2 W). To save power when they are not to be used for a long time, unplug them from the household AC outlet. You will need to reset some memory items after plugging in the main unit.

NOTE

The included AC power supply cords are for use with the main unit and wireless system only. Do not use them with other equipment. Also, do not use cords for other equipment with the main unit or wireless system.

- When the AC power supply cord is connected for the first time, "PLEASE WAIT" is displayed on the main unit's display for about 30 seconds and power is turned off automatically.

STEP 3 Setting up the unit

Turn on the main unit and wireless system

Turn on the power of the main unit and the wireless system after all connections are complete.

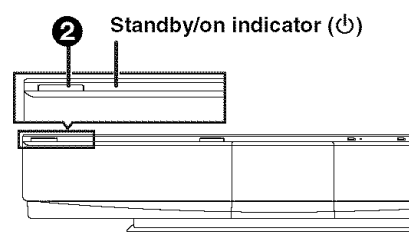
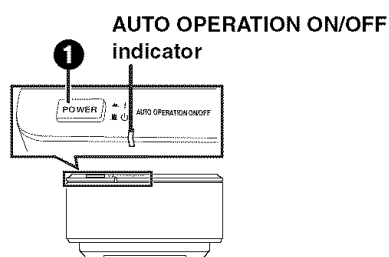

Preparation

Turn on the TV and select the appropriate video input on the TV.

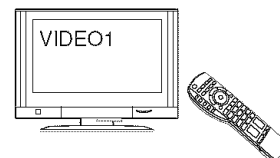

1 Press [POWER] (I, ⏻) on the wireless system.

- AUTO OPERATION ON/OFF indicator lights red when the wireless system is turned on and lights green when the wireless link is activated.

2 Press [POWER] (⏻) on the main unit.

- Standby/on indicator (⏻) goes out when the unit is turned on.
- When the link between the main unit and the wireless system is activated, "W2S" or "W4S" is illuminated in the main unit's display.

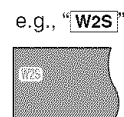

- If "W2S" or "W4S" is flashing in the main unit's display, check that the digital transmitter at the back of the main unit is inserted correctly.

Easy Setting

When the system is switched on for the first time, a screen for the basic settings is displayed automatically. Follow the on-screen prompts to make basic settings for the system.

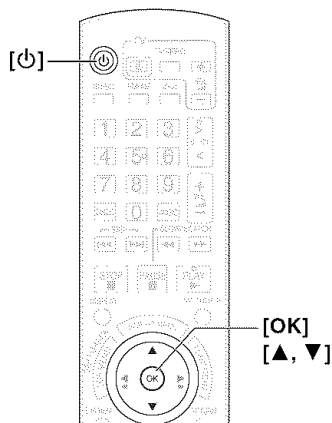

1 Press [⏻].

Setup screen appears.

- If this unit is connected to a Panasonic TV (VIERA) supporting HDAVI Control 2 or HDAVI Control 3 via an HDMI cable, then the "On-screen Language" and "TV Aspect" setting information on the TV are captured from the TV.

2 Follow the on-screen instructions and make the settings with [▲, ▼] and [OK].

"On-screen Language" (⇒ 33) and "TV Aspect" (⇒ 33) are set.

- You can perform this setup anytime by selecting "Easy Setting" in the Setup menu. (⇒ 32)
- You can also change these settings individually. (⇒ 33)

Presetting the radio stations automatically

Up to 30 stations can be set in each band, FM and AM.

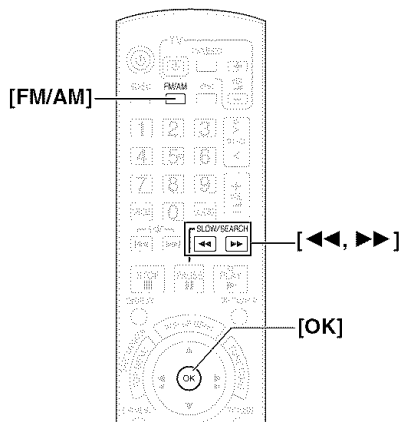

1 Press [FM/AM] to select "FM" or "AM".

2 Press [◀, ▶] to select the lowest frequency (FM: 87.9 or 87.5, AM: 520).

3 Press and hold [OK].

Release the button when "M" begins to flash.

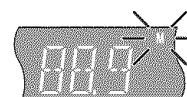

The tuner tunes to the lowest frequency and starts to preset all the stations it can receive into the channels in ascending order.

- "SET OK" is displayed when the stations are set, and the radio tunes to the last preset station.
- "ERROR" is displayed when automatic presetting is unsuccessful. Preset the channels manually (⇒ 18).

Control reference guide

Remote control

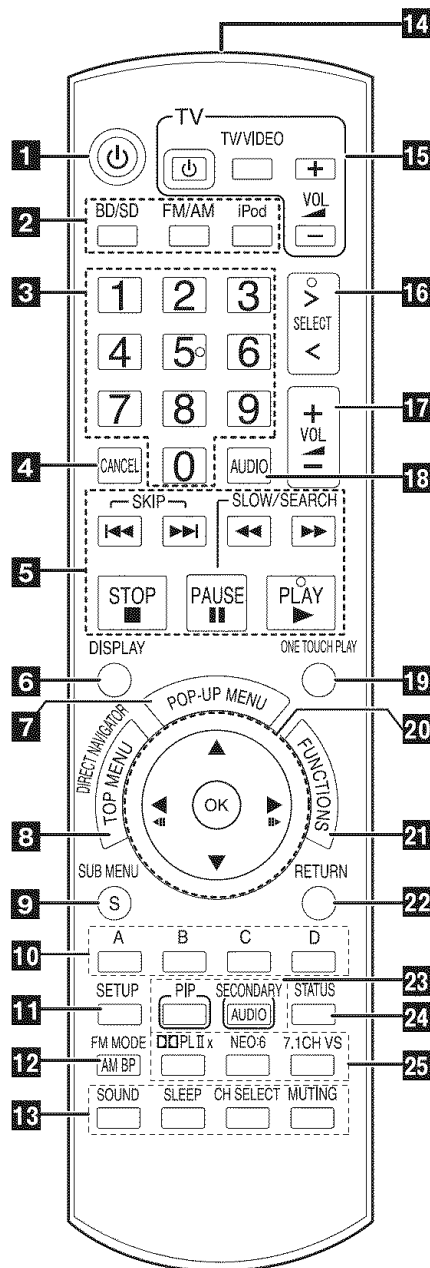

- 1** Turn the unit on and off (⇒ 14)
- 2** **Select the source**
[BD/SD]: Select disc drive or SD card drive (⇒ 14)
[FM/AM]: Select FM/AM tuner (⇒ 9, 18)
[iPod]: Select iPod as the source (⇒ 21)
- 3** **Numbered buttons**
Select preset radio stations and title numbers, etc./Enter numbers (⇒ 15, 18)
- 4** Cancel
- 5** **Basic playback control buttons** (⇒ 14, 15)
[◀, ▶]: Select preset radio stations (⇒ 18)
[◀◀, ▶▶]: Select radio station manually (⇒ 18)
- 6** Show on-screen menu (⇒ 30)
- 7** Show Pop-up menu (⇒ 24)
- 8** Show Top Menu/Direct Navigator (⇒ 14)
- 9** Show sub menu (⇒ 16, 23)
- 10** These buttons are used when operating a BD-Video disc that includes Java™ applications (BD-J). For more information about operating this kind of disc, please read the instructions that came with the disc.
The [A] and [B] buttons are also used with the "Title View", "Picture View" and "Album View" screens (⇒ 22).
- 11** Show Setup menu (⇒ 32)
- 12** Remove interference during radio reception (⇒ 18)
- 13** [SOUND]: Set the sound effect (⇒ 26)
[SLEEP]: Set the sleep timer (⇒ 16)
[CH SELECT]: Select speaker channel (⇒ 26)
[MUTING]: Mute the sound (⇒ 16)
- 14** Transmit the remote control signal
- 15** **TV operation buttons**
Aim the remote control at the Panasonic TV and press the button.
[TV]: Turn the TV on and off
[TV/VIDEO]: Switch the input channel
[+ - VOL]: Adjust the TV volume
• This may not work properly with some models.
- 16** **Select the source**
BD/DVD/CD ↔ SD ↔ FM ↔ AM ↔ IPOD ↔ D-IN ↔ AUX
↑
- 17** Adjust the volume of the main unit (⇒ 15)
- 18** Select audio (⇒ 16)
- 19** Start up and play a disc automatically (⇒ 28)
- 20** [▲, ▼, ◀, ▶]: Menu selection
[OK]: Selection
[◀, ▶]: Select preset radio station (⇒ 18)
[◀◀ (◀◀), ▶▶ (▶▶)]: Frame-by-frame (⇒ 16)
- 21** Show FUNCTIONS menu (⇒ 25)
- 22** Return to previous screen
- 23** [PIP]: Switch on/off Secondary Video (Picture-in-picture) (⇒ 24)
[SECONDARY AUDIO]: Switch on/off Secondary Audio (⇒ 24)
- 24** Show status messages (⇒ 16)
- 25** Enjoy surround sound (⇒ 27)

Wireless system

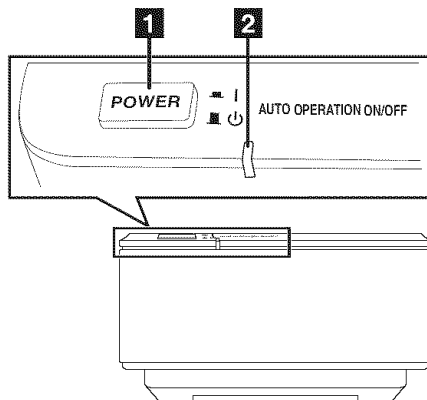

- 1** **Unit on/off button [POWER ■ I, ■ ⏻]** (⇒ 9)
Use this button to turn the unit on and off.
■ I: This unit is on.
■ ⏻: This unit is off.
- 2** **AUTO OPERATION ON/OFF indicator**
The indicator lights red when the wireless system is turned on and lights green when the wireless link is activated. When the wireless link is inactive for a long time, it turns red.

Main unit

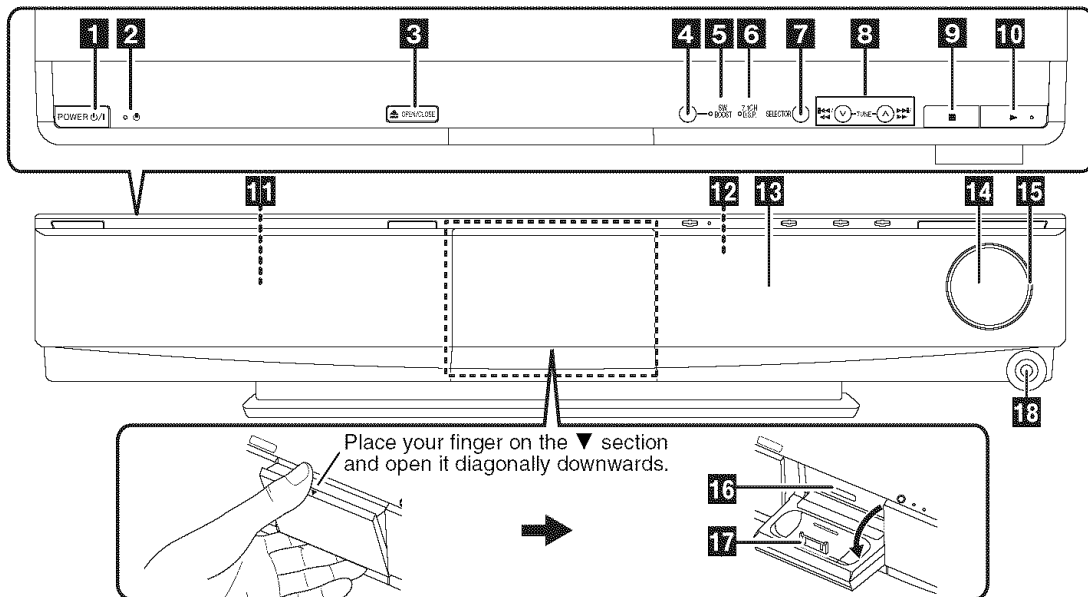

1 POWER button (POWER ϕ /I) (\Rightarrow 14)

Press to switch the unit from on to standby mode or vice-versa. In standby mode, the unit is still consuming a small amount of power.

2 Standby/on indicator (ϕ)

When the unit is connected to the household AC outlet, this indicator lights up in standby mode and goes out when the unit is turned on.

3 Open or close the disc tray (\Rightarrow 14)

4 SW BOOST (Subwoofer boost) button

Turn Subwoofer boost on/off (\Rightarrow 26)

5 SW BOOST (Subwoofer boost) indicator

Lights when Subwoofer boost is on (\Rightarrow 26)

6 7.1CH D.S.P. indicator

Illuminated during 7.1ch source playback.

7 Select the source

BD/DVD/CD \rightarrow SD \rightarrow FM \rightarrow AM \rightarrow IPOD \rightarrow D-IN \rightarrow AUX

8 Select the radio station manually (\Rightarrow 18)

Search/Slow-motion/Skip (\Rightarrow 15)

Search: Press and hold (During play)

Slow-motion: Press and hold (During pause)

Skip: Press

9 Stop (\Rightarrow 15)

10 Start play (\Rightarrow 14)

11 Disc tray (\Rightarrow 14)

12 Remote control signal sensor

13 Display

14 Adjust the volume of the main unit (\Rightarrow 14)

15 Volume indicator

• It is possible to set the indicator to turn on/off. (\Rightarrow 33, FL Display)

16 SD card slot (\Rightarrow 14)

17 Connect iPod (\Rightarrow 20)

18 Headphone terminal (\Rightarrow 14)

Rear panel terminals (\Rightarrow 6-8, 35-36)

CAUTION

Do not place objects in front of the unit. The disc tray may collide with objects when it is opened, and this may cause injury.

The unit's display

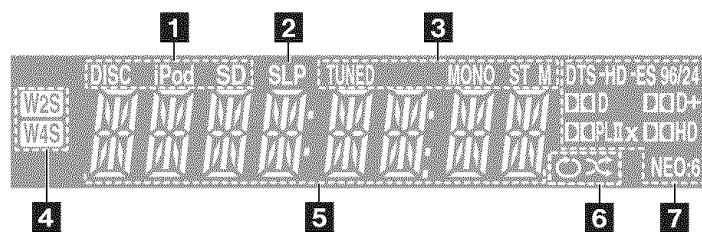

1 Drive indicator

DISC Lights when disc is ready to play.

iPod Lights when iPod is ready to play.

SD Lights when SD card is ready to play.

• The indicator blinks when reading data.

2 SLEEP indicator (\Rightarrow 16)

3 Radio broadcast display

TUNED Lights when receiving a radio broadcast (\Rightarrow 18)

MONO Lights when set to monaural reception (\Rightarrow 18)

ST Lights when set to stereo broadcast reception (\Rightarrow 18)

I Flashes during preset channel registration (\Rightarrow 9)

4 Wireless link indicator

W2S Lights when speaker setting (\Rightarrow 33, Speaker, 34, Speaker settings) is set to 5.1ch and link with wireless system is activated

W4S Lights when speaker setting (\Rightarrow 33, Speaker, 34, Speaker settings) is set to 7.1ch and link with wireless system is activated

• The indicator blinks when the wireless link is inactive for a long time.

5 Main display section

6 iPod indicator

REPEAT Illuminated during iPod repeat playback (EXTENDED mode only, \Rightarrow 21)

SHUFFLE Illuminated during iPod shuffle playback (EXTENDED mode only, \Rightarrow 21)

7 Audio signal indicator

DTS Lights when DTS decoder is being used.

DTS-HD Lights when DTS-HD decoder is being used.

DTS-ES Lights when DTS-ES decoder is being used.

DTS 96/24 Lights when DTS 96/24 decoder is being used.

DDD Lights when Dolby Digital decoder is being used.

DDD+ Lights when Dolby Digital Plus decoder is being used.

DDDIIIX Lights when Dolby Pro Logic II decoder is being used.

DDDIIIX Lights when Dolby Pro Logic IIX decoder is being used.





DDDHD Lights when Dolby TrueHD decoder is being used.

NEO:6 Lights when DTS NEO:6 matrix decoder is being used.

Disc and card information

Packaged discs

This chart shows the different type of retail/commercial discs you can use, and also includes the industry-standard logos that should appear on the discs and/or packaging.









Type of media/ Logo	Features	Indicated as	Type of media/ Logo	Features	Indicated as
BD-Video  	High Definition (HD) movie and music discs	BD-V	DVD-Video  	High quality movie and music discs	DVD-V
			CD 	Compact Discs (CD's) that contain audio and music • Operation and sound quality of CDs that do not conform to CD-DA specifications (copy control CDs, etc.) cannot be guaranteed.	CD

Recorded discs

This chart shows the different type of discs recorded with DVD recorders, DVD video cameras, personal computers, etc. that you can use.

Finalized

This mark means you must finalize the disc with the DVD recorder, etc. before playback. For details about finalizing, refer to the operating instructions for your equipment.

Type of media/ Logo	Formats	Indicated as	Type of media/ Logo	Formats	Indicated as
BD-RE  	<ul style="list-style-type: none"> Version 3 of the BD-RE Recording Format JPEG format 	BD-V JPEG	DVD-R DL Finalized  R DL	<ul style="list-style-type: none"> DVD-Video Format Version 1.2 of the DVD Video Recording Format AVCHD format 	DVD-V DVD-VR AVCHD
BD-R  	<ul style="list-style-type: none"> Version 2 of the BD-R Recording Format 	BD-V	+R/+RW/+R DL Finalized	<ul style="list-style-type: none"> +VR (+R/+RW Video Recording) Format AVCHD format 	DVD-V AVCHD
DVD-RAM  R A M R A M 4.7	<ul style="list-style-type: none"> Version 1.1 of the DVD Video Recording Format JPEG format AVCHD format 	DVD-VR JPEG AVCHD	CD-R/RW Finalized	<ul style="list-style-type: none"> CD-DA format MP3 format JPEG format 	CD MP3 JPEG
DVD-R/RW Finalized  R R 4.7  R W	<ul style="list-style-type: none"> DVD-Video Format Version 1.1 of the DVD Video Recording Format AVCHD format 	DVD-V DVD-VR AVCHD	<ul style="list-style-type: none"> It may not be possible to play the above discs in some cases due to the type of discs, the condition of the recording, the recording method and how the files were created. When a disc recorded in the AVCHD format is being played, the video may be paused for a few seconds at portions spliced, due to deletion or editing. 		

SD cards

This chart shows the different type of cards recorded with Panasonic High Definition Video Camera or personal computers, etc. that you can use.

Type of media	Formats	Indicated as
SD Memory Card* (from 8 MB to 2 GB) SDHC Memory Card (from 4 GB to 16 GB)	<ul style="list-style-type: none"> JPEG format AVCHD format 	JPEG AVCHD

* Including miniSD Card and microSD Card

- When using from 4 GB to 16 GB SD cards, only SD cards that display the SDHC logo can be used.
- This unit is compatible with SD Memory Cards that meet SD Card Specifications FAT12 and FAT16 formats, as well as SDHC Memory Cards in FAT32 format.
- In these operating instructions, the cards shown in the table (⇒ above) are comprehensively called SD cards.

• A miniSD Card and a microSD Card must be used with the attached adaptor that comes with the card.

- Useable memory is slightly less than the card capacity.
- If the SD card is formatted on a PC, you may not be able to use it on this unit. In this case, format the card on this unit (⇒ 24).



- We recommend using a Panasonic SD card.
- Keep the Memory Card out of reach of children to prevent swallowing.
- When a card recorded in the AVCHD format is being played, the video may be paused for a few seconds at portions spliced, due to deletion or editing.
- Switch the write-protect switch to the "LOCK" position to protect the content from accidental erasure.

Regarding BD-Video

- Enjoy *Final Standard Profile* functions (⇒ 24), such as picture-in-picture. The various functions differ depending on the disc.
- When playing a set of two or more BD-Video discs, the menu screen may continue to display even if the disc has been ejected.
- Dolby TrueHD, Dolby Digital Plus, DTS-HD Master Audio and DTS-HD High Resolution Audio are output as Dolby Digital when “BD-Video Secondary Audio” (⇒ 33) is set to “On”.

Note about using a DualDisc

The digital audio content side of a DualDisc does not meet the technical specifications of the Compact Disc Digital Audio (CD-DA) format so play may not be possible.

Tips for making MP3/JPEG discs

File format	MP3	JPEG
Playable media	CD-R/RW ^{*1}	CD-R/RW ^{*1} , DVD-RAM ^{*2} , BD-RE ^{*3} , SD card
Extension	Files must have the extension “.mp3” or “.MP3”.	Files must have the extension “.jpg” or “.JPG”.
Picture resolution	—	between 34×34 and 5120×3840 pixels (sub sampling is 4:2:2 or 4:2:0)
Bit rates	32 kbps to 320 kbps	—
Sampling frequency	44.1 kHz/48 kHz	—
Reference	<p>ID3 tags: version 1, 2.2, 2.3, 2.4 ID3 is a tag embedded in MP3 track to provide information about the track. This unit supports the versions listed above but only titles and the names of artists can be displayed.</p> <ul style="list-style-type: none"> • If there is a large amount of still picture data etc. within a MP3 file, play may not be possible. 	<ul style="list-style-type: none"> • MOTION JPEG: not supported • SD card: JPEG conforming DCF^{*4} (Design rule for Camera File system) Thawing Time: approx. 2 sec. (7M pixels)
	<ul style="list-style-type: none"> • English alphabet and Arabic numerals are displayed correctly. Other characters may not be displayed correctly. • The display order on this unit may differ from how the order is displayed on a computer. • Depending on how you create the media (writing software), files and folders may not play in the order you numbered them. • This unit is not compatible with packet-write format. • Depending on the recording conditions, the media may not play. • Operation may take time to complete when there are many files and/or folders and some files may not display or be playable. 	

^{*1} ISO9660 level 1 or 2 (except for extended formats), Joliet
This unit is compatible with multi-session.
This unit is not compatible with packet writing.

^{*2} Discs must conform to UDF 2.0.

^{*3} Discs must conform to UDF 2.5.

^{*4} Design rule for Camera File system: unified standard established by Japan Electronics and Information Technology Industries Association (JEITA).

Structure of MP3 and still pictures (JPEG) folders

You can play MP3 and still pictures (JPEG) with this unit by making folders on disc as shown (⇒ right).

- Folder structure created on a DVD-RAM, BD-RE or an SD card is not displayed.

MP3 files and folders in CD-R/RW

Prefix with 3-digit numbers in the order you want to play them.

Still pictures (JPEG) in CD-R/RW

Files inside a folder are displayed in the order they were updated or taken.

When the highest level folders are “DCIM” folders, they are displayed first on the tree.

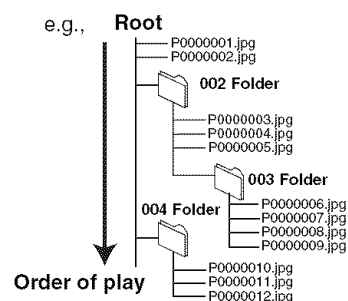

Discs that cannot be played

- BD-Video discs recorded at a rate of 50 frame per second
- BD-RE with the cartridge
- DVD-RAM that cannot be removed from their cartridges
- 2.6 GB and 5.2 GB DVD-RAM
- 3.95 GB and 4.7 GB DVD-R for Authoring
- Version 1.0 of DVD-RW
- +R 8 cm (3"), DVD-ROM, CD-ROM, CDV, SACD, Photo CD, MV-Disc and PD
- DVD-Audio
- Video CD and SVCD
- WMA discs
- DivX discs
- PAL discs
- HD DVD
- Other discs that are not specifically supported

Basic play (Playing video contents)

Preparation

Turn on the TV and select the appropriate video input on the TV.

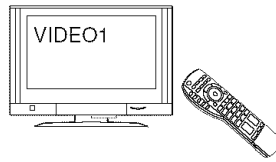

2 Insert a disc.
Press [**▲ OPEN/CLOSE**] to open the disc tray and load the disc.

Label facing up

- Press the button again to close the tray.
- Load double-sided discs so the label for the side you want to play is facing up.
- DVD-RAM: Remove the discs from their cartridges before use.

2 Insert an SD card.

Insert the card label up with the cut-off corner on the right.

- Press on the center of the card until it clicks into place.

• To remove the card, press on the center of the card and pull it straight out.

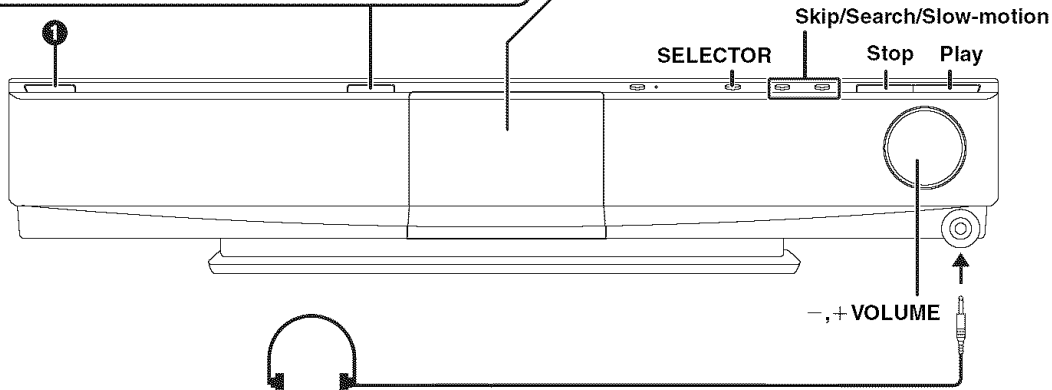

Headphones (not included)
Headphone plug type: Ø3.5 mm (1/8") stereo mini plug

- Reduce the volume before connecting.
- Audio is automatically switched to 2-channel stereo.
- To prevent hearing damage, avoid listening for prolonged periods of time. Excessive sound pressure from earphones and headphones can cause hearing loss.

- 1 Press [**⏻**] to turn on the unit.
- 2 Insert a disc or an SD card (⇒ see above).
 - If play does not start, press [**▶**] (PLAY).
 - If the screen prompting you to use the color buttons appears, continue to operate with the color buttons on the remote control.
 - If the menu is displayed, press [**▲**], [**▼**], [**◀**], [**▶**] to select the item and press [OK].

e.g., **BD-V**



e.g., **DVD-VR**

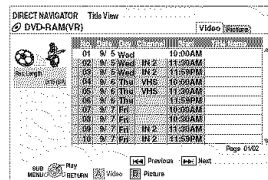

e.g., SD card containing pictures (JPEG) and HD movies (AVCHD)

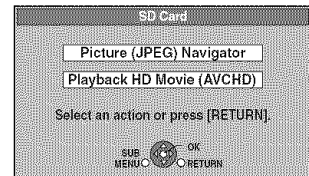

DISCS CONTINUE TO ROTATE WHILE MENUS ARE DISPLAYED.
Press [**■**] when you have finished playback to protect the unit's motor, your TV screen and so on.



To switch drives
Press [BD/SD] to select "BD/DVD/CD" or "SD".
Main unit: Press [SELECTOR].

• If a disc or an SD card is inserted while the unit is stopped, the drive switches automatically depending on the inserted media.

To display menus
BD-V **AVCHD** **DVD-VR** **DVD-V**
Press [TOP MENU/DIRECT NAVIGATOR].

• The producers of the disc can control how discs are played. So you may not always be able to control play as described in these operating instructions. Read the disc's instructions carefully.

e.g., "BD/DVD/CD"



e.g., "SD"



Other operations during play (These functions may not work depending on the disc.)

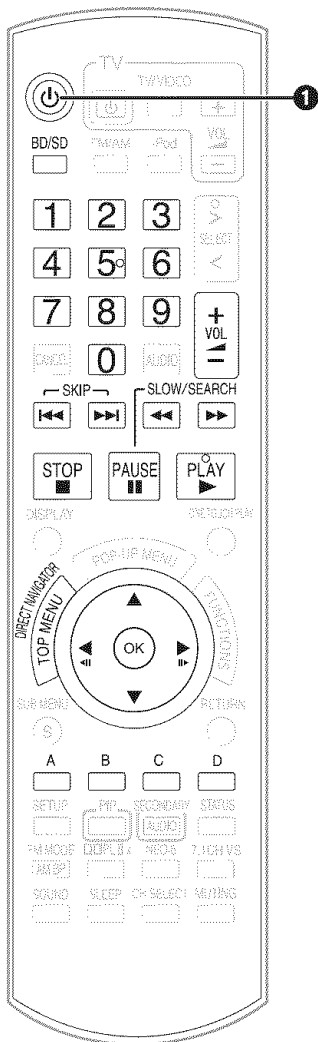

Stop

The stopped position is memorized.

Resume play function

Press  (PLAY) to restart from this position.

- The position is cleared if the tray is opened or you press  several times to display "STOP" on unit's display.

Pause

- Press  again or  (PLAY) to restart play.



Search/Slow-motion

The speed increases up to 5 steps.

- Press  (PLAY) to revert to normal playback speed.
- For some discs, the speed may not change.



Search

While playing, press  or .

- Press and hold  or  on the main unit.
- **BD-V AVCHD DVD-VR DVD-V**:
Audio is heard during first level of forward search.
- **CD MP3**: The speed is fixed to a single step.

Slow-motion

While paused, press  or .

- Press and hold  or  on the main unit.
- **BD-V AVCHD**: Forward direction  only.
- **DVD-VR**: If continued for approx. 5 minutes, slow-motion play pauses automatically.

Skip

Skip to the title, chapter or track you want to play.

- Each press increases the number of skips.

Adjust the volume

Starting from a selected item

Play starts from the selected title or chapter.

BD-V AVCHD

e.g., 5: [0] ⇒ [0] ⇒ [5]
15: [0] ⇒ [1] ⇒ [5]

DVD-V

e.g., 5: [0] ⇒ [5]
15: [1] ⇒ [5]

- While stopped (the image on the right is displayed on the screen), the title is designated. While playing, the chapter is designated.



(Continued on the next page)

Basic play (Playing video contents)

Other operations during play (These functions may not work depending on the disc.)

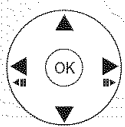

Frame-by-frame

While paused, press [**◀**] (**◀◀**) or [**▶**] (**▶▶**).

Each press shows the next frame.

- Press and hold to change in succession forward or backward.
- Press [**▶**] (PLAY) to revert to normal playback speed.
- **BD-V** **AVCHD**: Forward direction [**▶▶**] (**▶▶▶**) only.



Changing audio during play

BD-V **AVCHD** **DVD-V**
e.g., **DVD-V**



English is selected.

You can change the audio channel number each time you press the button. This allows you to change the soundtrack language (⇒ 30, Soundtrack), etc.

BD-V

When "BD-Video Secondary Audio" (⇒ 33) is set to "On", Dolby TrueHD, Dolby Digital Plus, DTS-HD Master Audio and DTS-HD High Resolution Audio are output as Dolby Digital regardless of this setting.

DVD-VR

AudioLR → AudioL → Audio R

"AudioLR" is selected



Muting the sound

"MUTING" flashes on the unit's display.



- To cancel, press [MUTING] again or adjust the volume.
- Muting is canceled when you switch the unit to standby.



Status messages

The status messages give you information about what is currently being played. Each time you press [STATUS], the information displayed will change.

e.g., **BD-V** Type of disc Play status

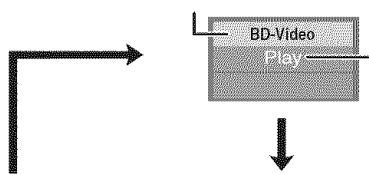

No display

T: Title PL: Playlist
C: Chapter
Items change depending on the disc played.

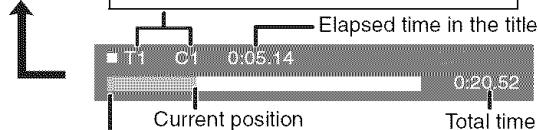

Depending on the kind of disc or the playback status, this display may not appear.

Screen Aspect

When black bars are shown at the top, bottom, left, and right sides of the screen, you can enlarge the image to fill the screen.

- 1 Press [SUB MENU].
- 2 Press [**▲**, **▼**] to select "Screen Aspect" and press [OK].
- 3 Press [**◀**, **▶**] to select "Side cut" or "Zoom".

e.g., **BD-V**



Normal: Normal output

Side cut: The black bars on the right and left sides of the 16:9 image disappear and the image is enlarged. Please note that the right and left sides of the image are cut off when the black bar is not displayed.

Zoom: The black bars on the top and bottom sides of the 4:3 image disappear and the image is enlarged. Please note that the top and bottom sides of the image are cut off when the black bar is not displayed.

- When "TV Aspect" (⇒ 33) is set to "4:3 Pan & Scan" or "4:3 Letterbox", the "Zoom" effect is disabled.

To exit the screen
Press [RETURN].



Setting the sleep timer

Press [SLEEP] to select the time (in minutes).

SLEEP 30 → SLEEP 60 → SLEEP 90 → SLEEP 120 → OFF



To confirm the remaining time

Press [SLEEP] again.

Chapter playback **DVD-VR**

- 1 While "Title View" screen is displayed
Press [**▲**, **▼**] to select the title and press [SUB MENU].

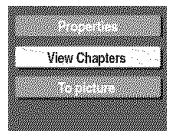

- 2 Press [**▲**, **▼**] to select "View Chapters" and press [OK].

Properties: To display the title properties (recording date, etc.)

To picture: Playing still pictures (⇒ 22)

- 3 Press [**◀**, **▶**] to select the chapter and press [OK].

To exit the screen
Press [SUB MENU].

DOLBY **PL** **II** x **NEO**:6 Enjoying stereo sources with surround sound effect

You can enhance stereo sources with surround sound effect.

To enjoy stereo sources in surround sound with Dolby Pro Logic II/Dolby Pro Logic IIX
Press [**□□PLIIX**].

To enjoy stereo sources in surround sound with DTS NEO:6
Press [**NEO:6**].

For more detailed information on this operation, please refer to the "Enjoying surround sound" section on page 27.

Enjoying TV with this unit's speakers

You can enjoy TV broadcasts with this unit's speakers.

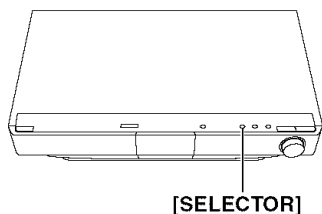

Preparation

Confirm the audio connection to the OPTICAL IN or AUX terminal on the main unit (⇒ 7).

- 1 Press [**>**, **<** SELECT] several times to select "D-IN" (DIGITAL IN) or "AUX".

Main unit: Press [SELECTOR].

- **D-IN (DIGITAL IN):** When connecting using OPTICAL IN terminal.
- **AUX:** When connecting using AUX terminal.
- When the system is connected to an HDAVI Control 2 or HDAVI Control 3-compatible TV via an HDMI cable, TV broadcast audio is output through the system speakers if the TV input is switched to TV tuner mode. See "Setting the TV audio for VIERA Link "HDAVI Control"" on page 28 for setting method.
- Reduce the volume on the TV to its minimum, and then adjust the volume of the main unit.

Enjoying TV sound from all speakers

You can enhance stereo sources with surround sound effect.

To enjoy TV in surround sound with Dolby Pro Logic II/Dolby Pro Logic IIX
Press [**DDPLIIX**].

To enjoy TV in surround sound with DTS NEO:6
Press [**NEO:6**].

For more detailed information on this operation, please refer to the "Enjoying surround sound" section on page 27.

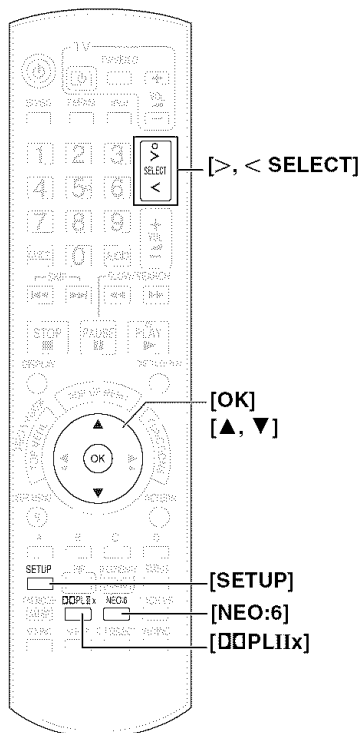

Making settings for digital audio input

Select to suit the type of audio from the OPTICAL IN terminal on the main unit.

- 1 Press [**>**, **<** SELECT] several times to select "D-IN" (DIGITAL IN).
Main unit: Press [SELECTOR].
- 2 Press [SETUP].
- 3 Press [**▲**, **▼**] to select "DUAL", "DRC" or "PCM FIX" and press [OK].
- 4 While the selected mode is displayed Press [**▲**, **▼**] to make the setting.

DUAL mode (Only works with Dolby Dual Mono)

MAIN

SAP

M+S (MAIN+SAP) (stereo audio)

"SAP" = Secondary Audio Program

- If this is set to "MAIN" or to "SAP", the PCM FIX modes (⇒ below) will automatically be set to "OFF".

DRC (Dynamic Range Compression)

ON:

Adjust for clarity even when the volume is low by compressing the range of the lowest sound level and the highest sound level. Convenient for late night viewing. (Only works with Dolby Digital)

OFF

PCM FIX modes

ON:

Select when receiving only PCM signals.

OFF:

Select when receiving Dolby Digital and PCM signals.

- If this is set to "ON", the DUAL mode (⇒ above) will automatically be set to "M+S".

- Audio that is input through the OPTICAL IN terminal cannot be output through the HDMI terminal.

Enjoying the FM/AM radio

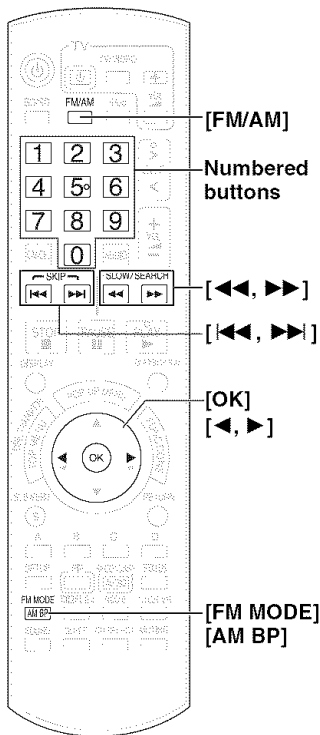
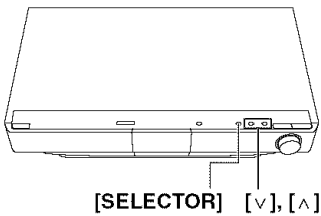

Manual tuning

- 1 Press **[FM/AM]** to select “FM” or “AM”.
Main unit: Press [SELECTOR].
- 2 Press **[◀◀, ▶▶]** to select the frequency.
Main unit: Press [v] or [^].
 - When a radio broadcast is being received, “TUNED” lights in the display.
 - When a stereo broadcast is being received, “ST” lights in the display.

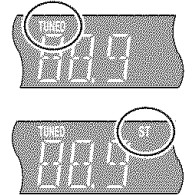

- To start automatic tuning, press and hold [◀◀, ▶▶] until the frequency starts scrolling. Tuning stops when a station is found.

Presetting stations manually

Up to 30 stations can be set in each band, FM and AM.

- 1 Press **[FM/AM]** to select “FM” or “AM”.
- 2 Press **[◀◀, ▶▶]** to select the frequency.
- 3 Press **[OK]**.
“P” and “M” begin to flash.

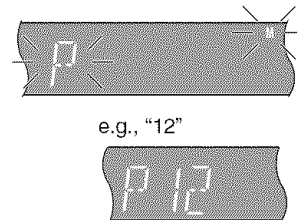

- 4 Press the numbered buttons to enter preset channel number.

- To select a 1-digit number
e.g., “1”: [1] ⇒ [OK].
- To select a 2-digit number
e.g., “12”: [1] ⇒ [2].

- A station previously stored is overwritten when another station is stored in the same channel preset.
- Repeat steps 2 to 4 to set other stations.

Selecting the preset channels

- 1 Press **[FM/AM]** to select “FM” or “AM”.
- 2 Press the numbered buttons to select the channel.

- To select a 1-digit number
e.g., “1”: [1] ⇒ [OK].
- To select a 2-digit number
e.g., “12”: [1] ⇒ [2].

Alternatively, press [◀◀, ▶▶] or [◀, ▶] to select the channel.

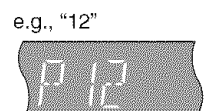

NOTE

If noise is excessive

When “FM” is selected

Press [FM MODE] to display “MONO”.

- Press the button again to cancel the mode.
- The mode is also canceled when you change the frequency.
- This setting can be preset for each broadcasting station. When “MONO” appears follow procedures 3 and 4 in “Presetting stations manually” (⇒ above).



When “AM” is selected

Press [AM BP] to select “AM BP1” or “AM BP2” that receives good reception.

Each time you press the button:

AM BP1 ↔ AM BP2 (BP=Beat Proof)

e.g., “AM BP1” is selected.



FM frequency step

Main unit only

The step is factory-set to 0.2-MHz (200-kHz), but you can change it to receive broadcasts allocated in 0.1-MHz (100-kHz) steps.

- 1 Press [SELECTOR] to select “FM”.
- 2 Press and hold [SELECTOR].

After a few seconds the display changes to show the current minimum frequency. Continue to hold the button down. The minimum frequency changes and the step is changed.

To return to the original step, repeat steps 1 and 2.

After changing the setting, previously preset frequencies will be cleared. Preset them again.

Playing music CD MP3

You can play generally available music CD or MP3 files recorded onto a CD-R/RW.

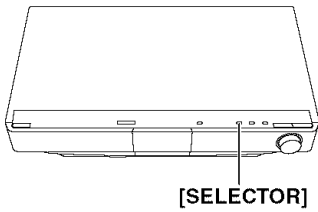

1 Insert a disc (⇒14).



TIPS

- If a disc containing data in different file formats is inserted, the file selection menu may be displayed. Press [▲, ▼] to select "MP3 Music" and press [OK].

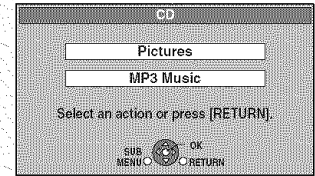

- If the menu is not displayed, press [BD/SD] to select "BD/DVD/CD".
Main unit: Press [SELECTOR].

2 Press [▲, ▼] to select the track and press [OK].

Play starts on the selected track.

e.g., CD

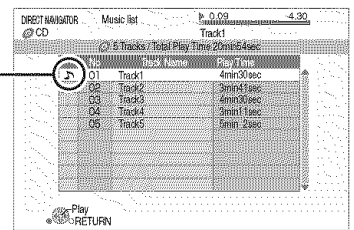

"" indicates the track currently playing.

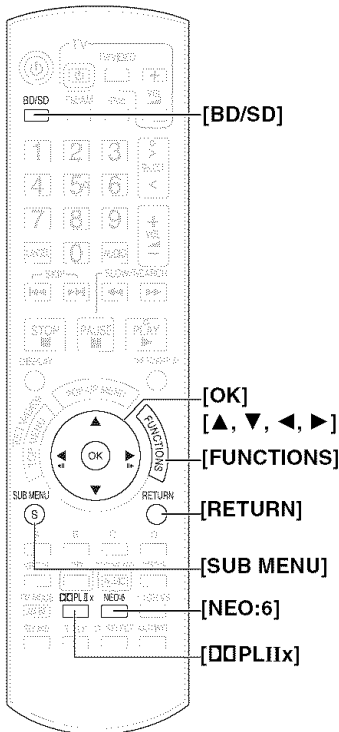

Enjoying music in surround sound

You can enhance stereo sources with surround sound effect.

To enjoy music in surround sound with Dolby Pro Logic II/Dolby Pro Logic IIx Press [DOLBY].

To enjoy music in surround sound with DTS NEO:6 Press [NEO:6].

For more detailed information on this operation, please refer to the "Enjoying surround sound" section on page 27.

Playing a track in another folder (MP3 only)

- While the "Music list" is displayed
Press [SUB MENU], press [▲, ▼] to select "Select Folder" and press [OK].

Selected folder No. /Total folders
If the folder has no track, "--" is displayed as folder number.

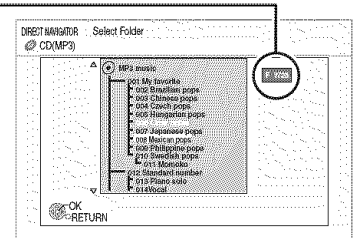

- Press [▲, ▼] to select a folder and press [OK].
The "Music list" for the folder appears.
• You cannot select folders that contain no compatible tracks.



TIPS

• To return to the previous screen

Press [RETURN].

• Discs containing data in different file formats.

To switch from the JPEG menu to MP3 menu, perform steps below.

- Press [FUNCTIONS].
- Press [▲, ▼] to select "Menu" and press [OK].
- Press [▲, ▼] to select "MP3 Music" and press [OK].

• You can use search and skip functions (⇒ 15).

• When the "Screen Saver Function" is set to "On" (⇒ 33), the screen switches to Screen Saver mode if there is no operation for 10 minutes after starting playback. (Playback continues.)

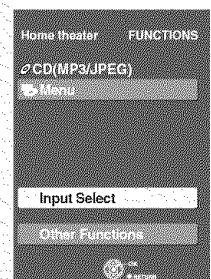

Playing an iPod on this unit

iPod videos/photos can be displayed on TV, and iPod music can be enjoyed through the system speakers, by connecting your iPod to the Dock for iPod on the main unit.

Connection

Preparation

- **To view videos/photos from the iPod.**
 - Ensure the video connection to the VIDEO OUT terminal on this unit (⇒ 7).
 - Operate the iPod menu to make the appropriate video/photo output settings for your TV. (Refer to the operating instructions of your iPod.)
- To display the picture, turn on the TV and select the appropriate video input mode.
- Before connecting/disconnecting the iPod, turn the main unit off or reduce the volume of the main unit to its minimum.

1 Open the Dock for iPod.

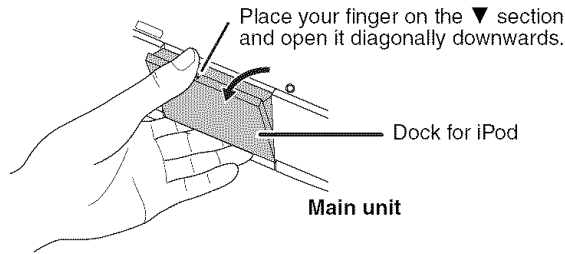

2 Connect the iPod (not included) firmly.

Recharging starts when the iPod is inserted.

e.g.,

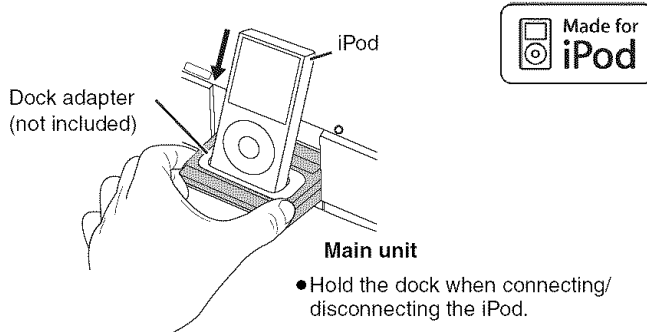

NOTE

About dock adapter

- Attach the dock adapter which should be supplied with your iPod to the dock for the stable use of the iPod. If you need an adapter, consult your iPod dealer.

About recharging the battery

- iPod will start recharging regardless of whether this unit is on or off.
- "IPOD 未*" will be shown on the main unit's display during iPod charging in main unit standby mode.
- Check iPod to see if the battery is fully recharged.
- If you are not using iPod for an extended period of time after recharging has completed, disconnect it from main unit, as the battery will be depleted naturally. (Once fully recharged, additional recharging will not occur.)

Compatible iPod

Name	Memory size
iPod touch	8 GB, 16 GB
iPod nano 3rd generation (video)	4 GB, 8 GB
iPod classic	80 GB, 160 GB
iPod nano 2nd generation (aluminum)	2 GB, 4 GB, 8 GB
iPod 5th generation (video)	60 GB, 80 GB
iPod 5th generation (video)	30 GB
iPod nano 1st generation	1 GB, 2 GB, 4 GB
iPod 4th generation (color display)	40 GB, 60 GB
iPod 4th generation (color display)	20 GB, 30 GB
iPod 4th generation	40 GB
iPod 4th generation	20 GB
iPod mini	4 GB, 6 GB



NOTE

- Compatibility depends on the software version of your iPod.
- Audio/video cannot be recorded or transmitted to iPods via this system.
- Panasonic makes no warranty over iPod data management.
- **For more information, refer to the operating instructions for iPod.**
- The contents of the operating instructions and those displayed on iPod may differ partially, but this will not fundamentally affect use of music playback.

Playback

This system features two different iPod playback modes.

The first of these is EXTENDED mode, for playback of music contents. With this mode, the menu screen on the system can be used to search for playlists and artist names, and to play music. The second mode is SIMPLE mode, which can be used for playback of three types of contents – music, photos, and videos. With this mode, simple operations such as play, stop, and search can be performed on the display of your iPod.



Enjoy music (EXTENDED mode)

1 Press [iPod] to select "IPOD".

The iPod automatically switches to this unit's display mode. iPod Music menu appears on the TV.

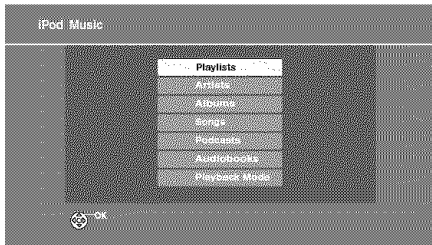
- If the menu screen is not displayed, press [SETUP].



Items	Selection/playback method
Playlists	Search from all playlists.
Artists	Search by artist name.
Albums	Search by album title.
Songs	Search from all songs registered on iPod.
Podcasts	Search by episode for radio programs downloaded from iTunes store.
Audiobooks	Search by title from audiobooks purchased from iTunes store or audible.com.
Playback Mode*	<p>Shuffle</p> <ul style="list-style-type: none"> • Off: Cancel • Songs: Play all songs on iPod in random order. • Albums: Play all songs on album in random order. <p>"" is displayed on the unit's display when "Songs" or "Albums" is selected.</p> <p>Repeat</p> <ul style="list-style-type: none"> • Off: Cancel • One: Play single song repeatedly. • All: Play all songs from selected item (e.g., Playlists, Albums, etc.) repeatedly. <p>"" is displayed on the unit's display when "One" or "All" is selected.</p>

* **Playback modes during connection/when disconnected**
System may be operated in same playback mode as set with iPod when connected. Playback may also be continued on iPod with same settings as made on system after disconnection.

2 Press [▲, ▼] to select an item and press [OK].

- Play will start from the selected song if this operation is repeated several times.
- Press [RETURN] to return to the previous screen.

e.g.,

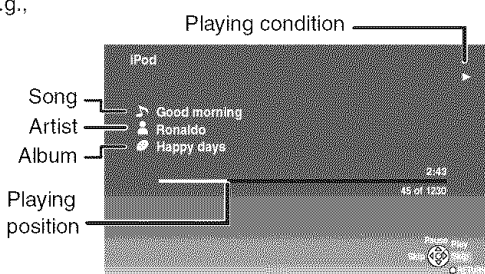

Clear/display iPod Music menu during playback.
Press [TOP MENU].

Enjoy videos/photos (SIMPLE mode)

You can also play music using SIMPLE mode.

1 Press [iPod] to select "IPOD".

2 Press [SETUP] to switch the iPod to its own display mode.

Proceed operations through display of iPod.

- If the iPod Music menu (⇒ left) is displayed, press [SETUP]. "SIMPLE" will be shown on the main unit's display.

3 Switch the TV input to video in.

4 Play a slideshow or video on your iPod.

The picture will be displayed on your TV.

You can also use the remote control to operate iPod menu.

- [▲, ▼]: To navigate menu items
- [OK]: To go to the next menu
- [RETURN]: To return to the previous menu

Basic controls (For music and videos only)

Buttons	Functions
[▶] (PLAY)	Play
[■]	Pause
[]	<ul style="list-style-type: none"> • Press [▶] (PLAY) to restart play. • Playback start position may not be stored in memory in certain cases.
[◀◀, ▶▶]	Skip
(Press and hold) [◀◀, ▶▶]	Search

You can enjoy surround sound effect when you press [DOLBY] or [NEO:6] (⇒ 27).

Playing still pictures JPEG

You can play still pictures recorded onto a BD-RE, DVD-RAM, CD-R/RW and SD card.

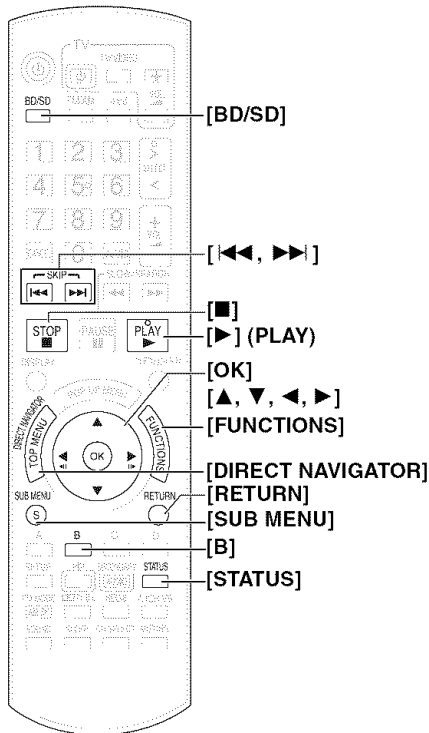
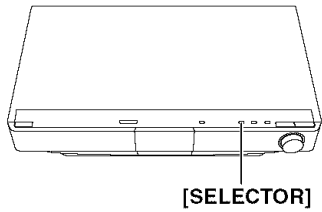

1 Insert a disc or an SD card (⇒ 14).



TIPS

• If a disc or an SD card containing data in different file formats is inserted, the file selection menu may be displayed.

SD card:

Press [**▲**, **▼**] to select "Picture (JPEG) Navigator" and press [**OK**].

CD-R/RW:

Press [**▲**, **▼**] to select "Pictures" and press [**OK**].

e.g., SD card

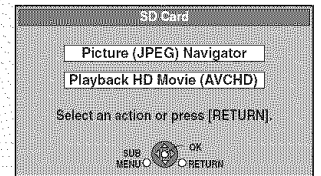

BD-RE, DVD-RAM

"Album View" screen is displayed.

• When the "Title View" screen is displayed, press the [**B**] button to switch to the "Album View" screen.

e.g.,

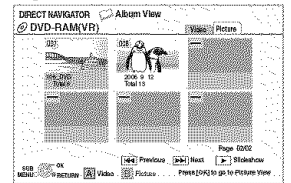

CD-R/RW, SD Card

"Picture View" screen is displayed.

⇒ Go to step 3

e.g.,

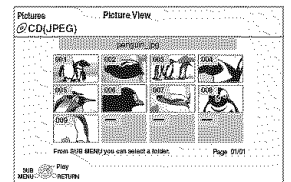

- If the menu is not displayed, press [**BD/SD**] to select "BD/DVD/CD" or "SD".
Main unit: Press [**SELECTOR**].
- To show other pages
Press [**◀**, **▶**].

2 Press [**▲**, **▼**, **◀**, **▶**] to select the album and press [**OK**].

3 Press [**▲**, **▼**, **◀**, **▶**] to select the still picture and press [**OK**].

- Small-sized still pictures are displayed with a frame.
- To display the previous or next still picture
Press [**◀**, **▶**].

e.g.,

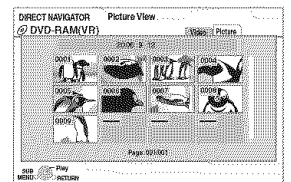

TIPS

CD-R/RW

Discs containing data in different file formats.

To switch from the MP3 menu to JPEG menu, perform steps below.

- 1 Press [**FUNCTIONS**].
- 2 Press [**▲**, **▼**] to select "Menu" and press [**OK**].
- 3 Press [**▲**, **▼**] to select "Pictures" and press [**OK**].

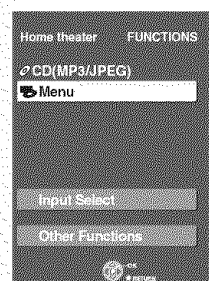

NOTE

To return to the previous screen
Press [**RETURN**].

To exit the screen
Press [**DIRECT NAVIGATOR**].

Useful functions during still picture play

Start Slideshow

You can display still pictures one by one at a constant interval.

BD-RE, DVD-RAM

- While the "Album View" screen is displayed Press [▲, ▼, ◀, ▶] to select the album and press [SUB MENU].
- Press [▲, ▼] to select "Start Slideshow" and press [OK].

- You can also start slideshow by pressing [▶] (PLAY) after selecting the album.

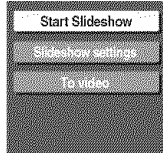

CD-R/RW, SD card

- While the "Picture View" screen is displayed Press [SUB MENU].
- Press [▲, ▼] to select "Start Slideshow" and press [OK].

To stop slideshow

Press [■].

Slideshow with music

SD card only

If a music CD is inserted in the disc tray while playing slideshows, the music CD starts playing automatically as background music.

- You cannot search or skip on a music CD.
- When the slideshow stops, playback of the music CD also stops.

Slideshow settings

In step 2 in "Start Slideshow" above,

- Press [▲, ▼] to select "Slideshow settings" and press [OK].

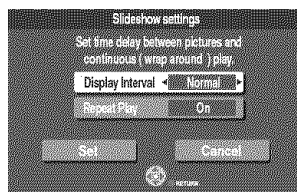

- To change the display interval

Press [▲, ▼] to select "Display Interval" and press [◀, ▶] to select the interval ("Long", "Normal" or "Short").

- When a still picture with large number of pixels is played, the display interval may become longer. Even if the setting is changed, the display interval may not become shorter.

To repeat slideshow

Press [▲, ▼] to select "Repeat Play" and press [◀, ▶] to select "On" or "Off".

- Press [▲, ▼, ◀, ▶] to select "Set" and press [OK].

Rotate

- While playing (except for slideshow) Press [SUB MENU].
- Press [▲, ▼] to select "Rotate Right" or "Rotate Left" and press [OK].

- The rotation information will be stored until the unit is turned off or the media is removed.

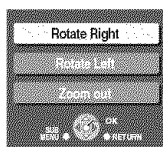

Zoom out

This function is only available for small-sized still pictures.

- While playing (except for slideshows) Press [SUB MENU].
- Press [▲, ▼] to select "Zoom out" and press [OK].

- To cancel "Zoom out", press [▲, ▼] to select "Zoom in" in step 2 and press [OK].
- The zoom-out information will not be stored.

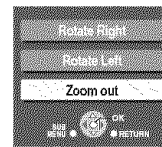

To select the still pictures in another folder

BD-RE, DVD-RAM

To switch to another higher folder

(Only if there is a multiple number of higher folders recognizable)

- While the "Album View" screen is displayed Press [SUB MENU].
- Press [▲, ▼] to select "Select Root folder" and press [OK].

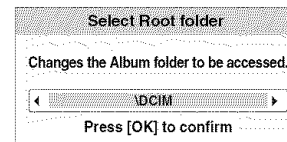

- Press [◀, ▶] to select the higher folder and press [OK].

CD-R/RW

- While the "Picture View" screen is displayed Press [SUB MENU].
- Press [▲, ▼] to select "Select Folder" and press [OK].
- Press [▲, ▼] to select a folder and press [OK].
The "Picture View" screen for the folder appears.

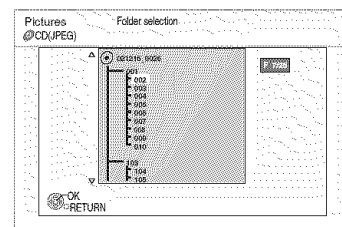

To show the picture properties

While playing
Press [STATUS] twice.

e.g., JPEG on DVD-RAM
Shooting date

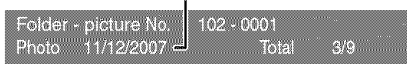

To exit, press [STATUS].

Different kinds of playback for BD-Video BD-V

Some discs permit a variety of interactive functions in addition to the ordinary playback operation.

Showing Pop-up menu

The Pop-up menu is a special feature available with some BD-Video discs. This menu may vary with discs. For the operating method, refer to the instructions for the disc.

- 1 Press [POP-UP MENU].
- 2 Press [▲, ▼, ◀, ▶] to select the item and press [OK].

e.g.,

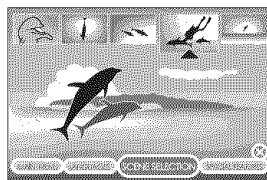

TIPS

- Pop-up menu also appears by pressing [SUB MENU] and selecting "Pop-up Menu".
- To exit the screen**
- Press [POP-UP MENU].

- The *Final Standard Profile* ["Picture-in-picture", "Virtual Package" (⇒ below), etc.] is a new playback function of BD-Video. Contents of playback and the operating method may vary with the disc. For details, refer to the instructions for the disc.

Playing secondary video (picture-in-picture) and secondary audio

Secondary video can be played from a disc compatible with the picture-in-picture function.

For the playback method, refer to the instructions for the disc.

To turn on/off secondary video
Press [PIP].

Secondary video is played.

- "PiP ON" is displayed.
- Press the button to turn it ON and OFF.

To turn on/off audio with the secondary video
Press [SECONDARY AUDIO].

The secondary audio is played.

- "Secondary Audio ON" is displayed.
- Press the button to turn it ON and OFF.

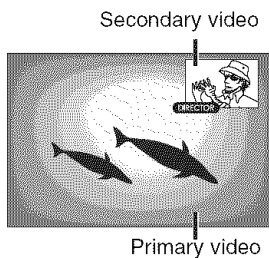

NOTE

- Only the primary video is played during search/slow-motion or frame-by-frame.

Virtual package

For a disc compatible with the virtual package (⇒ 43), data is copied to other media (⇒ 43, Local storage) from the disc to use the different functions while playing the data.

For this unit, data is copied to an SD card.

The methods for copy and playback and the required available capacity on the card may vary with the disc. For details, refer to the instructions for the disc.

To use the above functions, it is recommended that you format the card on this unit. Format the card using the following procedures. BD-Video data, such as secondary video recorded on the card, can also be erased with the following procedures.

Formatting SD cards/Deleting data

- 1 Insert an SD card (⇒ 14).
- 2 Press [FUNCTIONS].
- 3 Press [▲, ▼] to select "Other Functions" and press [OK].
- 4 Press [▲, ▼] to select "Card Management" and press [OK].
- 5 Press [▲, ▼] to select "BD-Video Data Erase" or "Format SD Card" and press [OK].
- 6 Press [◀, ▶] to select "Yes" and press [OK].
- 7 Press [◀, ▶] to select "Start" and press [OK].

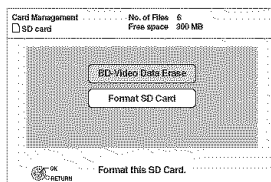

NOTE

- If the SD card is removed from this unit when using data that was copied with the virtual package function, disc playback stops.
- Images and audio may freeze momentarily during playback.
- Data cannot be copied in the following cases.
 - The card is protected.
 - Available capacity on the card is too small.
 - Delete unnecessary data or use a new card.
- When the function fails to work properly, even if the data is copied, format the card again with this unit. (In this case, all data will be erased.)



TIPS

- If an SD card with files in different formats is used, images and audio may not play back properly. It is recommended that you use an SD card with no data or an SD card formatted on this unit.



NOTE

- It is impossible to restore data after formatting the card or erasing the data. Once a card is formatted, all data including those recorded on the PC is erased as well, even if the data were protected with other equipment. Confirm whether the card can be formatted.

Showing FUNCTIONS menu

Some functions of this unit can be operated from the FUNCTIONS menu.

- 1 Press [FUNCTIONS].
 - Items displayed vary according to the chosen selector and media.
- 2 Press [▲, ▼] to select the item and press [OK].

e.g., **DVD-V**

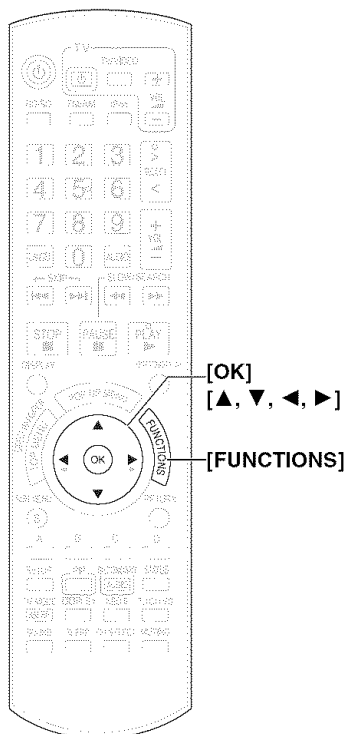

Items	Functions
Playback DISC Playback	Starts playing disc/SD Card.
Top Menu	Shows a disc top menu.
Menu	Shows a disc menu. To play AVCHD (⇒ 14) To play MP3 (⇒ 19) To play JPEG (⇒ 22)
Music	Select to play Music on iPod ⇒21, Step 2 in "Enjoy music (EXTENDED mode)"
Videos/Photos	Select to play Videos/Photos on iPod ⇒21, Step 3 in "Enjoy videos/photos (SIMPLE mode)"
Input Select	Select the source. e.g., DVD-V BD/DVD/CD: To play BD-Video, DVD-Video, AVCHD (⇒ 14) To play CD, MP3 (⇒ 19) SD card: To play AVCHD (⇒ 14) To play JPEG (⇒ 22) FM: To enjoy the FM radio (⇒ 18) AM: To enjoy the AM radio (⇒ 18) iPod: To play iPod Press [▲, ▼] to select "Music" or "Videos/Photos" and press [OK]. • Music: ⇒21, Step 2 in "Enjoy music (EXTENDED mode)" • Videos/Photos: ⇒21, Step 3 in "Enjoy videos/photos (SIMPLE mode)" Digital in*: To enjoy TV broadcasts with this unit's speakers (⇒ 17) AUX (TV)*: To enjoy TV broadcasts with this unit's speakers (⇒ 17) * "(TV)" is displayed next to items set for TV SOUND input. (⇒ 28, Setting the TV audio for VIERA Link "HDAVI Control")
Other Functions	Setup: You can change the unit's settings using Setup menu (⇒ 32).
	Card Management: Formatting SD cards/Deleting data (⇒ 24)
	Playlists: You can play playlists created on DVD-VR. Press [▲, ▼, ◀, ▶] to select the playlist and press [OK].

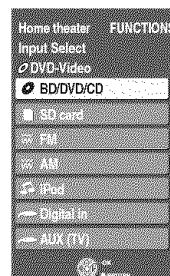

Advanced operations

Changing audio quality/sound field

- The following sound effects may not be available or have no effect with some sources, or when headphones are used (⇒ 14).
- You may experience a reduction in sound quality when these sound effects are used with some sources. If this occurs, turn the sound effects off.

Using Subwoofer boost

Main unit only

You can enhance the subwoofer effect with strong bass.

Press [SW BOOST] on the main unit.

- The SW BOOST indicator lights when Subwoofer Boost is turned on.

Setting the sound effects

- 1 Press [SOUND].
- 2 Press [▲, ▼] and select item for setting.

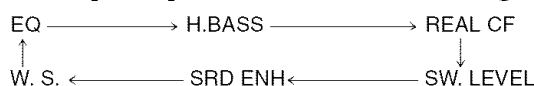

- 3 Press [OK].

Equalizer (EQ)

You can select sound quality settings.

- 4 Press [▲, ▼] to select the item.

Each time you press the button:

- HEAVY:** Adds punch to rock.
- CLEAR:** Clarifies higher sounds.
- SOFT:** For background music.
- FLAT:** Cancel (no effect is added).

Enhancing the bass sound (H.BASS)

You can enhance low-frequency sound so that heavy bass sound can be heard clearly.

- 4 Press [▲, ▼] to select “ON” or “OFF”.

Real Center Focus (REAL CF)

You can make the sound of the center speaker seem like it is coming from within the TV.

- 4 Press [▲, ▼] to select “ON” or “OFF”.

- This function is effective when playing audio containing center channel sound or when Dolby Pro Logic IIX/Dolby Pro Logic II or DTS NEO:6 is on.

Adjusting the subwoofer level (SW. LEVEL)

You can adjust the amount of bass. The unit automatically selects the most suitable setting according to the type of playback source.

- 4 Press [▲, ▼] to select the item.

- SUB W 1:** Weakest effect
- SUB W 2:** Middle effect
- SUB W 3:** Strongest effect

Surround Enhancer (SRD ENH)

This function automatically makes speaker adjustment to enhance the surround sound effect.

- 4 Press [▲, ▼] to select “ON” or “OFF”.

- This function is effective when playing audio containing surround channel sound or when Dolby Pro Logic IIX/Dolby Pro Logic II or DTS NEO:6 is on.
- This sound effect have no effect when receiving AM radio broadcast.

Using Whisper-mode Surround (W. S.)

You can enhance the surround effect for low volume 5.1-channel sound. (Convenient for late night viewing.)

- 4 Press [▲, ▼] to select “ON” or “OFF”.

- This function is effective when playing audio containing surround channel sound or when Dolby Pro Logic IIX/Dolby Pro Logic II or DTS NEO:6 is on.
- This sound effect have no effect when receiving AM radio broadcast.

Adjusting speaker level during play

- 1 Press [CH SELECT] to select the speaker.

Each time you press the button:

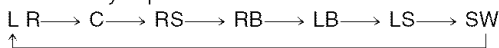

- L R: Front speaker (left and right)
- C: Center speaker
- RS: Surround speaker (right)
- RB: Surround back speaker (right)
- LB: Surround back speaker (left)
- LS: Surround speaker (left)
- SW: Subwoofer

- Speakers with settings (⇒ 34) set to “ ” will not be displayed.
- The channels not included in the playing audio will not be displayed (Subwoofer is displayed even if not included).

Adjusting the balance of the front speakers

(When “L R” selected)

- 2 Press [◀, ▶] to adjust the balance of the front speakers.

e.g.,

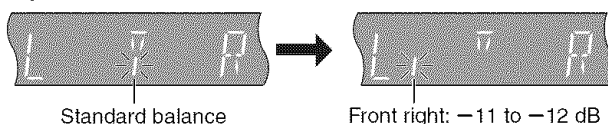

Adjusting the speaker level

(When other option selected)

- 2 Press [▲] (increase) or [▼] (decrease) to adjust the speaker level for each speaker.

- C, SW: +6 dB to -6 dB
- RS, RB, LB, LS: +10 dB to -10 dB

e.g., Subwoofer



Enjoying surround sound

- The following sound effects may not be available or have no effect with some sources, or when headphones are used (⇒ 14).
- You may experience a reduction in sound quality when these sound effects are used with some sources. If this occurs, turn the sound effects off.

Dolby Pro Logic IIX/Dolby Pro Logic II

When 5.1ch speakers connected

Dolby Pro Logic II will be used.

The technology enables you to play 2-channel stereo sources on 5.1-channel.

When 7.1ch speakers connected (⇒ 4, Enjoying 7.1-channel surround sound)

Dolby Pro Logic IIX will be used.

The technology enables you to play 2-channel stereo or 5.1-channel sources on

7.1-channels (sounds assigned to surround back channels become stereo in playback).

The technology also makes surround back channels available for the playback of Dolby

Digital Surround EX sources (sounds assigned to surround back channels become monaural in playback).

Press [DOLBIIX].

Each time you press the button:

MOVIE: This mode produces good effects when you play commercial film titles in the Dolby Surround format.

MUSIC: This mode produces good effects when you play music.

EX: This mode produces good effects when you play commercial film titles recorded in the Dolby Digital Surround EX format.

OFF: Cancel (no effect is added)

- “EX” may only be selected when speaker setting (⇒ 33, Speaker, 34, Speaker settings) is set to 7.1-channel.
- You cannot select “EX” when playing 2-channel stereo sources.
- You cannot use this function when playing titles recorded in the DTS-ES format.

DTS NEO:6

When 5.1ch speakers connected

The technology enables you to play 2-channel stereo sources on 5.1-channel.

When 7.1ch speakers connected (⇒ 4, Enjoying 7.1-channel surround sound)

The technology enables you to play 2-channel stereo or 5.1-channel sources on 6.1-channels.

Press [NEO:6].

Each time you press the button:

CINEMA: This mode produces good effects when playing movies.

MUSIC: This mode produces good effects when playing music.

OFF: Cancel (no effect is added)

- The “CINEMA” mode is available for 2-channel stereo Dolby Digital and DTS sources containing surround data. The “MUSIC” mode is available for the same sources containing no surround data.
- You cannot use this function when playing titles recorded in the DTS-ES format.

7.1ch Virtual Surround

You can enjoy 7.1-channel surround-like effect using 5.1-channel speakers.

This function is effective only when playing 6ch sources or above and speaker setting (⇒ 33, Speaker, 34, Speaker settings) is set to 5.1-channel.

Press [7.1CH VS].

Each time you press the button:

7.1CH VS SIDE-SP: Effective when surround speakers are placed either side of the seat position.

7.1CH VS REAR-SP: Effective when surround speakers are placed behind the seat position.

7.1CH VS OFF: Cancel (no effect is added)

- You cannot use this function when playing titles recorded in the Dolby Digital Surround EX format.

- These functions only work during playback through system speakers.

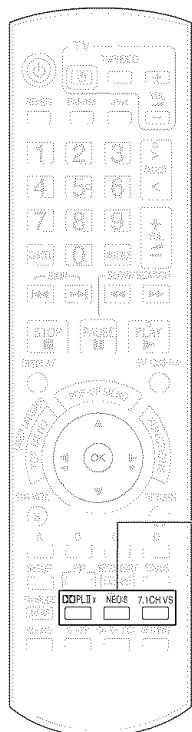

[DOLBIIX]
[NEO:6]
[7.1CH VS]

Linked operations with the TV

(VIERA Link™ “HDAVI Control™”)

What is VIERA Link “HDAVI Control”?

VIERA Link™ is a new name for EZ Sync™.

VIERA Link “HDAVI Control” is a convenient function that offers linked operations of this unit, and a Panasonic TV (VIERA) under “HDAVI Control”. You can use this function by connecting the equipment with an HDMI cable. See the operating instructions for connected equipment for operational details.

Preparation

- 1 Confirm that the HDMI connection has been made (⇒ 7).
- 2 Set “VIERA Link” to “On” (⇒ 33).
- 3 To complete and activate the connection correctly, turn on all VIERA Link “HDAVI Control” compatible equipment and set the TV to the corresponding HDMI input mode for this unit.

Setting the TV audio for VIERA Link “HDAVI Control”

Select between “AUX” and “D-IN” to work with the linked operations. Confirm the audio connection to the AUX terminal (for “AUX”) or OPTICAL IN terminal (for “D-IN”) (⇒ 7).

- 1 Press [>, < SELECT] to select “AUX” or “D-IN”.
- 2 Press [SETUP].
- 3 (When “D-IN” is selected)
Press [▲, ▼] to select “TV SOUND”.
- 4 Press [OK].
- 5 Press [▲, ▼] to switch “AUX” or “D-IN” and press [OK].

Whenever the connection or settings are changed, reconfirm the points above.



NOTE

● VIERA Link “HDAVI Control”, based on the control functions provided by HDMI which is an industry standard known as HDMI CEC (Consumer Electronics Control), is a unique function that we have developed and added. As such, its operation with other manufacturers’ equipment that supports HDMI CEC cannot be guaranteed.

● **This unit supports “HDAVI Control 3” function.** “HDAVI Control 3” is the newest standard (current as of December, 2007) for Panasonic’s HDAVI Control compatible equipment. This standard is compatible with Panasonic’s conventional HDAVI equipment.

● Please refer to individual manuals for other manufacturers’ equipment supporting VIERA Link function.

● **It is recommended that you use Panasonic’s HDMI cable.**

Recommended part number:

RP-CDHG10 (1.0 m/3.3 ft.), RP-CDHG15 (1.5 m/4.9 ft.), RP-CDHG20 (2.0 m/6.6 ft.), RP-CDHG30 (3.0 m/9.8 ft.), RP-CDHG50 (5.0 m/16.4 ft.), etc.

● **Non-HDMI-compliant cables cannot be utilized.**

What you can do with “HDAVI Control”

One touch play

You can turn on this unit and TV, and start playing with a single press of a button.

Press [ONE TOUCH PLAY].

This unit’s speakers will be automatically activated (⇒ right, Speaker control).

- This function also works if you press [▶] (PLAY) on this unit’s remote control when this unit is in standby mode.
- Playback may not be immediately displayed on the TV. If you miss the beginning portion of playback, press [◀◀] or [◀◀] to go back to where playback started.

Automatic input switching

- When you switch the TV input to TV tuner mode, this unit will automatically switch to “AUX” or “D-IN”.
[This function does not work when the iPod selector (SIMPLE mode) is chosen. (⇒ 21)]
- When you start disc play, the TV will automatically switch its input mode for this unit.

Automatic lip-sync function (for HDAVI Control 3)

Delay between audio and video is automatically adjusted, enabling you to enjoy smooth audio for the picture (⇒ 33, Time Delay).

- This function works only when “BD/DVD”, “SD”, “AUX” or “D-IN” is selected as the source on this unit.

Speaker control

You can select whether audio is output from the unit’s speakers or the TV speakers by using the TV menu settings. For details, refer to the operating instructions of your TV.

Home theater

This unit’s speakers are active.

- When this unit is in standby mode, changing the TV speakers to this unit’s speakers in the TV menu will automatically turn the unit on and select “AUX” or “D-IN” as the source.
- The TV speakers are automatically muted.
- You can control the volume setting using the volume or mute button on the TV’s remote control. (The volume level is displayed on the main unit’s FL display.)
- To cancel muting, you can also use the home theater remote control (⇒ 16, Muting the sound).
- If you turn off this unit, TV speakers will be automatically activated.

TV

TV speakers are active.

- The volume of this unit is set to “0”.
– This function works only when “BD/DVD/CD”, “SD”, “AUX” or “D-IN” is selected as the source on the home theater system.
- Audio output is 2-channel audio.

Power off link

When the TV is turned off, this unit goes into standby mode automatically.

- This function works only when “BD/DVD/CD”, “SD”, “IPOD”, “AUX” or “D-IN” is selected as the source on this unit.

※ “AUX” or “D-IN” works depending on the “TV SOUND” setting (⇒ above, Setting the TV audio for VIERA Link “HDAVI Control”).

Easy control only with VIERA remote control

If you connect this unit to a TV that has "HDAVI Control 2" or "HDAVI Control 3" function with an HDMI cable, you can operate this unit using the following buttons on the TV remote control.

[▲, ▼, ◀, ▶], [OK], [RETURN], [SUB MENU] and colored buttons

Use the remote control for this unit to operate any other buttons (numbered buttons, etc.) that are not listed above.

• Refer to the TV operating instructions for operating TV.

Using the FUNCTIONS menu to operate this unit

By using the TV remote control, you can play media using the FUNCTIONS menu.

- 1 Press the button for VIERA Link on the TV remote control.
- 2 Select the home theater.
 - The FUNCTIONS menu is displayed
- 3 Select the desired items on the FUNCTIONS menu (⇒ 25).



Using the sub menu to operate this unit

By using the TV remote control, you can play discs using the "Control Panel" and display the Top Menu (for BD-Video and DVD-Video) or Pop-up Menu (for BD-Video).

• This works only during "BD/DVD" or "SD" playback and resume modes.

- 1 Press [SUB MENU].
 - You cannot use the sub menu while the Top Menu for BD-Video or DVD-Video is displayed.

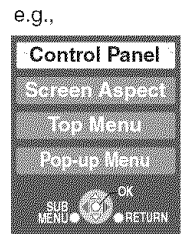

- 2 Select an item, then press [OK].

Control Panel	Control Panel is displayed. Follow the indications on the screen (⇒ below).
Screen Aspect	(⇒ 16)
Top Menu BD-V AVCHD DVD-V	Top menu is displayed.
Menu DVD-V	Menu is displayed.
Pop-up Menu BD-V AVCHD	Pop-up menu is displayed.
Rotate Right JPEG	Rotate the still picture.
Rotate Left JPEG	
Zoom in JPEG	Enlarge or shrink the still picture.
Zoom out JPEG	

Using the Control Panel

You can operate the playback with the indicated controls.

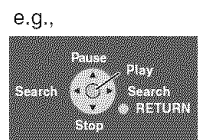

Note

- Depending on the menu, some button operations cannot be performed from the TV's remote control.
- You cannot input numbers with the numbered buttons on the TV's remote control ([0] to [9]). Use this unit's remote control to select the playlist etc.

When you want to leave the TV on and set only this unit to standby mode

Press [⏻] on this unit's remote control and set to standby mode.

When not using "HDAVI Control"

Set "VIERA Link" in the Setup menu to "Off". (⇒ 33)

Changing settings with the on-screen menu

On-screen menu operations

- 1 Press [BD/SD] to select "BD/DVD/CD" or "SD".
- 2 Press [DISPLAY].
- 3 Press [▲, ▼] to select the menu and press [▶].
- 4 Press [▲, ▼] to select the item and press [▶].
- 5 Press [▲, ▼] to select the setting.

e.g., BD-Video

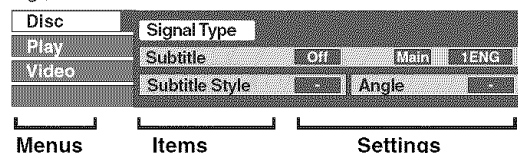

NOTE

• Depending on the condition of the unit (playing, stopped, etc.) and disc contents, there may be some items that you cannot select or change.



TIPS

• Some items can be changed by pressing [OK].

To exit the on-screen menu
Press [DISPLAY].

What you can change with the on-screen menu

Menus	Items	Settings and details
Disc	Signal Type	BD-V <ul style="list-style-type: none"> • Primary Video Video: The video recording method appears. (⇒ below, Video recording method) Soundtrack: Select the type of audio or language. (⇒ below, Language, Audio attribute) • Secondary Video Video: Select on/off of images. The video recording method appears. (⇒ below, Video recording method) Soundtrack: Select on/off of audio and the language. (⇒ below, Language, Audio attribute)
	Video	AVCHD The video recording method appears. (⇒ below, Video recording method)
	Soundtrack	AVCHD DVD-V Select the type of audio or language. (⇒ below, Language, Audio attribute) DVD-VR The disc's audio attributes appear. (⇒ below, Audio attribute)
	Subtitle	BD-V AVCHD DVD-V Turn the subtitle on/off and select the language. (⇒ below, Language) DVD-VR (Only discs that contain subtitle on/off information) Turn the subtitle on/off.
	Subtitle Style	BD-V Select the subtitle style.
	Audio channel	DVD-VR (⇒ 16, Changing audio during play)
	Angle	BD-V DVD-V Select the number of the angle.

Some items may be changed only on the disc specific menu. (⇒ 14, 24)

Language		
ENG: English	DAN: Danish	THA: Thai
FRA: French	POR: Portuguese	POL: Polish
DEU: German	RUS: Russian	CES: Czech
ITA: Italian	JPN: Japanese	SLK: Slovak
ESP: Spanish	CHI: Chinese	HUN: Hungarian
NLD: Dutch	KOR: Korean	FIN: Finnish
SVE: Swedish	MAL: Malay	*: Others
NOR: Norwegian	VIE: Vietnamese	

Audio attribute	
LPCM/□□ Digital/□□ Digital+/ □□ TrueHD/DTS/DTS-HD	Signal type
ch (channel)	Number of channels
k (kHz)	Sampling frequency
b (bit)	Number of bits

Video recording method	
MPEG-2	This is a standard for compressing and decompressing color motion pictures efficiently. This compression method is used for DVDs, etc.
MPEG-4 AVC	These are standards for compressing and decompressing color motion pictures more efficiently than MPEG-2 and used for Blu-ray Discs, etc.
VC-1	

Menus	Items	Settings and details
Play	Repeat Play	<p>(Only when the elapsed time is being displayed on the unit's display.) Selects the item which you want to repeat. The items displayed differ depending on the type of disc.</p> <ul style="list-style-type: none"> ● All tracks All tracks ● Chapter Chapter ● Playlists Playlist ● Title Title ● One track Track ● Off <p>Select "Off" to cancel.</p>
	Random	<p>CD MP3</p> <p>While playing, press [▲, ▼] to select "On". Random playback starts from the next track.</p> <ul style="list-style-type: none"> ● On ● Off
Video	Picture	<p>BD-V AVCHD DVD-VR DVD-V</p> <p>Select the picture quality mode during play.</p> <ul style="list-style-type: none"> ● Normal: Default setting ● Soft: Soft picture with fewer video artifacts ● Fine: Details are sharper ● Cinema: Mellows movies, enhances detail in dark scenes. ● User: You can make further adjustments. (⇒ below) <p>① Press [▶] to select "Picture Adjustment" and press [OK]. ② Select the item using [▲, ▼] and adjust it with [◀, ▶].</p> <ul style="list-style-type: none"> Contrast: Increases the contrast between light and dark parts of the picture (-7 to +7). Brightness: Brightens the picture (0 to +15). Sharpness: Adjusts the sharpness of the edges of the horizontal lines (-6 to +6). Color: Adjusts the shade of the picture's color (-7 to +7). Gamma: Adjusts the brightness of dark portions of the screen (0 to +5). 3D NR: Reduces the rough noise in the background to give a greater feeling of depth (0 to +4). When "BD-Video 24p Output" is set to "On", this function may not operate. (⇒ 33) Integrated NR: Smooths block noise and reduces the smudging that appears around contrasting sections of the picture (0 to +3).
	Progressive	<p>If images are stretched from right to left, set to "Off". [Only when you have selected "480p" in "Component Video Resolution" (⇒ 33)]</p> <ul style="list-style-type: none"> ● Depending on the type of TV used, the video may be stretched horizontally when video is output in progressive mode. When this occurs, select "Off" and the video will then be output as "480i". ● This setting will be fixed to "On" if you connect with an HDMI cable and set "HDMI Video Mode" to "On" (⇒ 33). ● When using a component video cable and progressive output is on, closed captions cannot be displayed.
	Transfer	<p>[When "Progressive" (⇒ above) is set to "On".] Select the method of conversion for progressive output to suit the type of material being played (⇒ 43, Film and video).</p> <ul style="list-style-type: none"> ● Auto (normal): Automatically detects the film and video content, and appropriately converts it. ● Video: Select when using "Auto", and the content is distorted.

Changing settings with the setup menu

Change the unit's settings, if necessary. The settings remain intact even if you switch the unit to standby.

Setup menu operations

- 1 Press [BD/SD] to select "BD/DVD/CD" or "SD".
- 2 While stopped
Press [SETUP].
- 3 Press [▲, ▼] to select the tab and press [OK].
- 4 Press [▲, ▼] to select the menu and press [OK].
- 5 Press [▲, ▼, ◀, ▶] to select the option and press [OK].

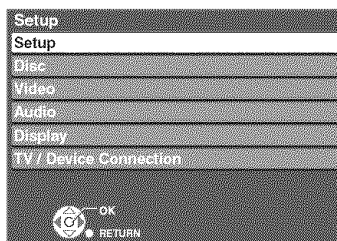

NOTE

• There may be differences in operation methods. If this happens, follow the on-screen instructions for the operation.



TIPS

To return to the previous screen
Press [RETURN].

To exit the screen
Press [SETUP].

Summary of settings

Underlined items are the factory presets.

"Setup" tab

Off Timer Select how long the unit remains on when it is not being used. • Effective only when "BD/DVD/CD" or "SD" is selected as source.	• 2 Hours • <u>6 Hours</u> • Off
Remote Control Code (⇒ 42)	• <u>Set Code 1</u> • Set Code 2
Easy Setting You can execute basic settings (On-screen Language, TV Aspect). • When you select "Yes", follow the on-screen instructions.	• Yes • <u>No</u>
Restore Default Settings This returns all values in the Setup menu and the on-screen menu, except for "Remote Control Code", "On-screen Language", "DVD-Video Ratings", "BD-Video Ratings" and "Speaker" to the default settings.	• Yes • <u>No</u>

"Disc" tab

DVD-Video Ratings Set a ratings level to limit DVD-Video play.	Follow the on-screen instructions. Enter a 4-digit password with the numbered buttons when the password screen is shown. It will be the common password for both "DVD-Video Ratings" and "BD-Video Ratings". • Do not forget your password.	<ul style="list-style-type: none"> • 8 No Limit: All DVD-Video can be played. • 1 to 7: Prohibits play of DVD-Video with corresponding ratings recorded on them. • 0 Lock All: Prohibits play of all DVD-Video.
BD-Video Ratings Set an age limit of BD-Video play.		<ul style="list-style-type: none"> • <u>No Limit</u>: All BD-Video can be played. • 0 to 254 year(s): Prohibits play of BD-Video with corresponding ratings recorded on them.
Audio Language	Choose the language for audio, subtitle and disc menus. BD-V DVD-V	<ul style="list-style-type: none"> • <u>English</u> • French • Spanish • Original: The original language of each disc will be selected. • Other ****
Subtitle Language	<ul style="list-style-type: none"> • Some discs start in a certain language despite any changes you make here. • When the selected language is not available on the disc, the default language is played. There are discs where you can only switch the language from the menu screen. (⇒ 14, 24) • Enter a code (⇒ 37) with the numbered buttons when you select "Other ****". 	<ul style="list-style-type: none"> • <u>Automatic</u>: If the language selected for "Audio Language" is not available, subtitles of that language will automatically appear if available on that disc. • English • French • Spanish • <u>Other ****</u>
Menu Language		<ul style="list-style-type: none"> • <u>English</u> • French • Spanish • <u>Other ****</u>

"Video" tab

Still Mode (paused video) BD-V AVCHD DVD-V Select the type of picture shown when you pause playback (⇒ 43, Frames and fields).	<ul style="list-style-type: none"> • <u>Auto</u> • Field: Select if jittering occurs when "Auto" is selected. (The picture is coarser.) • Frame: Select if small text or fine patterns cannot be seen clearly when "Auto" is selected. (The picture is clearer and finer.)
Seamless Play DVD-VR Select the play mode between playlist chapter segments and partially deleted titles.	<ul style="list-style-type: none"> • <u>On</u>: The chapters in playlists are played seamlessly. This does not work while searching or when there are several audio types included on the playlist. Additionally, the positioning of chapter segments may change slightly. • Off: The points where chapters in playlists change are played accurately, but the picture may freeze for a moment.
Black Level Control Select lighter or darker for adjusting the black level control to the desired setting for picture enhancement.	<ul style="list-style-type: none"> • <u>Lighter</u>: When video is output from VIDEO OUT terminal. • Darker: When video is output from COMPONENT VIDEO OUT terminal.

“Audio” tab

Dynamic Range Compression	● On
BD-V AVCHD DVD-V (Dolby Digital, Dolby Digital Plus and Dolby TrueHD only) Change the dynamic range (⇒ 43) for late night viewing.	● Off
Speaker	Make settings for your speakers. (⇒ 34)
BD-Video Secondary Audio BD-V Turn on/off the clicking sound on the menu and audio with secondary video in picture-in-picture mode. ● When this is set to “On”, Dolby TrueHD, Dolby Digital Plus, DTS-HD Master Audio and DTS-HD High Resolution Audio are output as Dolby Digital.	● On: The primary audio and secondary audio are mixed and output. The sampling frequency is converted to 48 kHz. ● Off: The clicking sound on the menu and secondary audio are not output.

“Display” tab

Status Messages Choose whether to show status messages automatically.	● Automatic ● Off
On-screen Language Choose the language for these menus and on-screen messages.	● English ● Français ● Español
Screen Saver Function This is to prevent burn-in on the screen. ● When this is set to “On”, the masked-off area on the screen becomes gray. [Only when connecting with an HDMI cable or a component video cable and “HDMI Resolution” (⇒ below) is set to any other mode than “480p”, or “Component Video Resolution” (⇒ below) is set to “720p” or “1080i”.]	● On: If there is no operation for 10 minutes or more, the displayed screen switches to the other states automatically. – When the Direct Navigator or FUNCTIONS menu is displayed, the display returns to the screen saver mode. – When CD or MP3 is played, the display returns to the screen saver mode. (Playback continues.) – When still pictures are shown (except for slideshows), the display returns to the Direct Navigator screen. – During FM/AM radio broadcast reception, the display returns to the screen saver mode. (Reception continues.) ● Off
FL Display Changes the brightness of the unit’s display. ● The brightness of the volume indicator (⇒ 11) is also changed.	● Bright ● Dim: The display is dimmed. ● Auto: The display is dimmed, but brightens when you perform some operations.
License	Information about the software used by this unit is displayed.

“TV/Device Connection” tab

TV Aspect Set to match the type of TV connected.	When connected to a 4:3 aspect TV: ● 4:3 Pan & Scan: Video recorded for a widescreen is played as Pan & Scan (unless prohibited by the producer of the disc). When playing BD-Video, video is output as “4:3 Letterbox”. ● 4:3 Letterbox: Video recorded for a widescreen is played in the letterbox style. When connected to a 16:9 widescreen TV: ● 16:9: Video recorded for 4:3 aspect screen is displayed as a 4:3 ratio image in the center of the screen. ● 16:9 Full: Video recorded for 4:3 aspect screen is displayed as a horizontally stretched 16:9 image.
Time Delay When connected with a Plasma display, adjust if you notice the audio is out of sync with the video.	● Auto ● 0ms ● 20ms ● 40ms ● 60ms ● 80ms ● 100ms ● 120ms ● 140ms When using VIERA Link “HDAVI Control” with “HDAVI Control 3” compatible TV (⇒ 28), select “Auto”. Audio and video will automatically be set in sync. (This works only when “BD/DVD”, “SD”, “AUX” or “D-IN” is selected as the source.)
HDMI Connection ● Press [OK] to show the following settings.	
HDMI Video Mode Select “On” when video is output from HDMI AV OUT terminal.	● On: Images are output from the HDMI terminal in the resolution set in “HDMI Resolution”. Video from COMPONENT VIDEO OUT terminal is output as “480i”. ● Off: Images are output in the resolution set in “Component Video Resolution”.
HDMI Resolution The items supported by the connected devices are indicated on the screen as “*”. When any item without “*” is selected, the images may be distorted.	● Auto: Automatically selects the output resolution best suited to the connected TV (1080p, 1080i, 720p or 480p). ● 480p ● 720p ● 1080i ● 1080p
BD-Video 24p Output When playing BD-Video recorded in 24 frames, this unit displays each frame at 1/24 second intervals—the same interval originally shot with the film movie. ● This item can be set only when the unit is connected to a TV with an HDMI terminal that supports 1080/24p input.	● On: Images in 24p are output in 24p as they are. (This is effective only when “HDMI Resolution” is set to “Auto” or “1080p” and “TV Aspect” is set to “16:9” or “16:9 Full”.) However, – when video is being output at 24 frames, images from any other terminal than the HDMI terminal may not be output properly. – when images other than 24p are played, images are output at 60p. ● Off
HDMI RGB Output Range Effective when connected to a device that only supports RGB output.	● Standard: ● Enhanced: When the black and white images are not distinct.
HDMI Audio Output This setting selects whether or not to output audio from HDMI. ● When this is set to “On”, Dolby TrueHD, Dolby Digital Plus, DTS-HD Master Audio, DTS-HD High Resolution Audio are output as Dolby Digital from system speakers.	● On: To output audio through TV speakers (output as 2ch PCM, regardless of source audio format channel number). ● Off: To output audio through system speakers. (The audio is output using the settings of the main unit.)
VIERA Link Set to use “HDAVI Control” function when connected with an HDMI cable to a device that supports “HDAVI Control”.	● On: Select when you want to use “HDAVI Control”. ● Off: Select when you do not want to use “HDAVI Control”.
Component Video Resolution This sets the video output resolution when using COMPONENT VIDEO OUT terminals.	● 480i ● 480p ● 720p ● 1080i Even if you select “720p” or “1080i”, images are output in 480p when you play DVD-Video.

Changing settings with the setup menu

Speaker settings

Speaker presence settings

(Center, surround and surround back speakers only)

1 Press [▲, ▼, ◀, ▶] to select the speaker icon and press [OK].

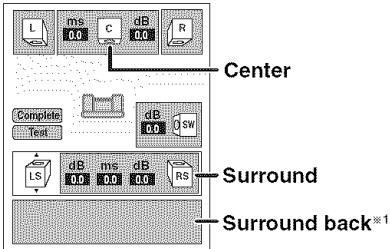

2 Press [▲, ▼] to select the setting and press [OK].

Icon examples:

Center		Select when the center speaker is connected and in use.
		Select when the center speaker is not connected or not in use.
Surround		Select when the surround speakers are connected and in use.
		Select when the surround speakers are not connected or not in use.
Surround back ^{*1}		Select when – using the optional Panasonic wireless system SH-FX67 and speaker system SB-HS100A to enjoy 7.1ch surround sound. – connecting an amplifier to the SURROUND BACK terminal at the back of the main unit to enjoy 7.1ch surround sound.
		Select when the surround back speakers are not connected or not in use.

*1 Surround back speakers are set to "X" by default.

*2 You can select "X" only when surround speakers are set to "X".

e.g.,

5.1ch speaker connection

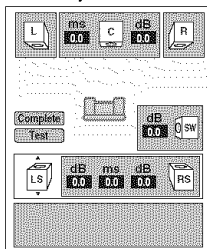

7.1ch speaker connection

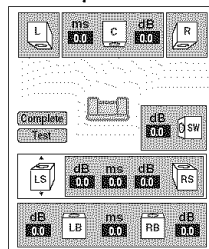

Changing the delay time

(Effective when playing multi-channel audio)

(Center, surround and surround back speakers only)

For optimum listening with 7.1/5.1-channel sound, all the speakers, except for the subwoofer, should be the same distance from the seating position. If you have to place the center, surround and surround back speakers closer to the seating position, adjust the delay time to make up for the difference.

If either distance (A) or (B) is less than (C), find the difference in the relevant table and change to the recommended setting.

5.1ch speaker connection

7.1ch speaker connection

Approximate room dimensions

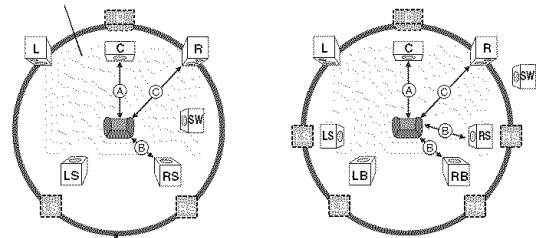

Circle of constant primary listening distance

: Actual speaker position

: Ideal speaker position

(A)(B)(C): Primary listening distance

1 Press [▲, ▼, ◀, ▶] to select the delay time box and press [OK].

2 Press [▲, ▼] to select the setting and press [OK].

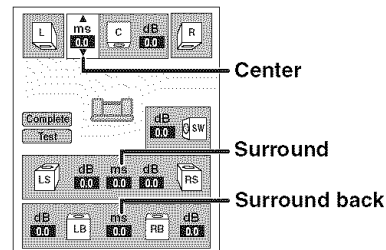

(A) Center speaker

Difference	Setting
Approx. 34 cm (1 ft. 1 in.)	1.0 ms
Approx. 68 cm (2 ft. 2 in.)	2.0 ms
Approx. 102 cm (3 ft. 4 in.)	3.0 ms
Approx. 136 cm (4 ft. 5 in.)	4.0 ms
Approx. 170 cm (5 ft. 6 in.)	5.0 ms

(B) Surround/Surround back speakers

Difference	Setting
Approx. 170 cm (5 ft. 6 in.)	5.0 ms
Approx. 340 cm (11 ft. 1 in.)	10.0 ms
Approx. 510 cm (16 ft. 8 in.)	15.0 ms

Adjusting speaker level

(Effective when playing multi-channel audio)

1 Select "Test" and press [OK].

A test signal is output.

Front (L) → Center → Front (R) → Surround (RS)

Surround (LS) ← Surround back (LB) ← Surround back (RB)

2 While listening to the test signal, press [▲, ▼] to adjust the volume of each speaker.

Center speaker: (+6 dB to -6 dB)

Surround and Surround back speakers: (+10 dB to -10 dB)

• Set each speaker level according to the volume of the Front (L) and Front (R) speaker volume respectively.

3 Press [OK].

The test signal stops.

• No signal is output for the subwoofer. To adjust its volume, see page 26, Adjusting speaker level during play.

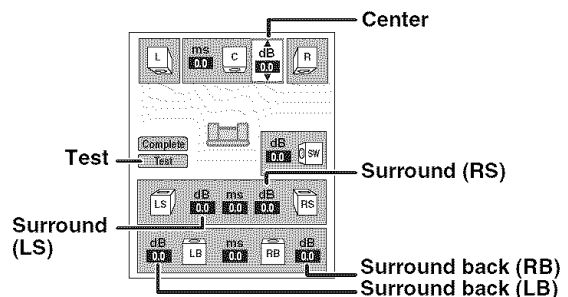

To finish the speaker setting

Press [▲, ▼, ◀, ▶] to select "Complete" and press [OK].

Optional connections and settings

Connection to Set Top Box (Satellite receiver, Cable box, etc) or video cassette recorder

Use the following connections when you want to output audio of your cable TV or VCR through this unit's speakers.

- Do not connect through the video cassette recorder.
Due to copy guard protection, the picture may not be displayed properly.
- Turn off all equipment before connection and read the appropriate operating instructions.

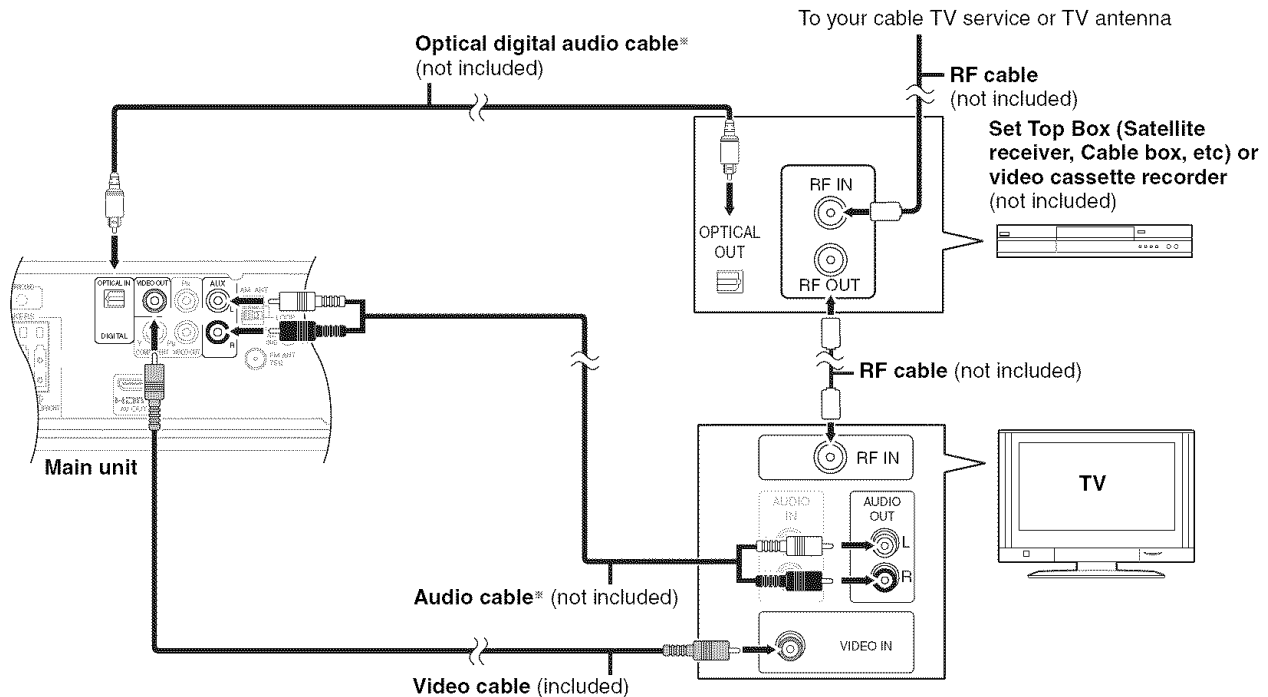

This unit can decode the surround signal from the Set Top Box (Satellite receiver, Cable box, etc).
Press [**>**, **<** SELECT] several times to select "D-IN" (DIGITAL IN).

*These audio connections will enable you to play audio from your television through your home theater system (⇒ 17).

Connection to a TV with component video cable

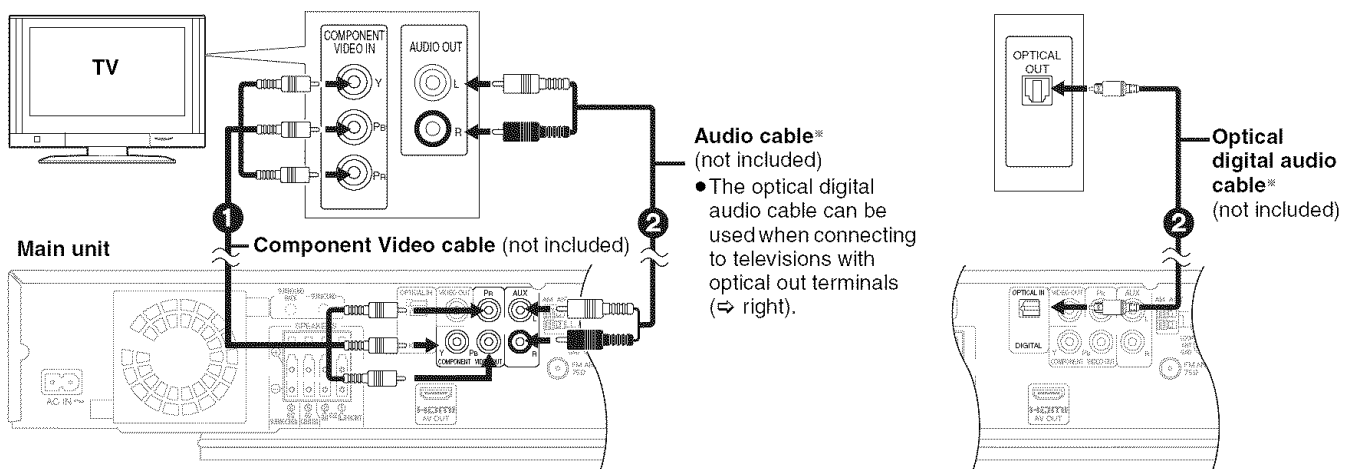

- Connect terminals of the same color.
- Set "Black Level Control" to "Darker". (⇒ 32)
- Some discs prohibit high definition video output from COMPONENT VIDEO OUT terminals. In this case, video resolution is converted to 480p.

*These audio connections will enable you to play audio from your television through your home theater system (⇒ 17).



To enjoy high definition/progressive video

- Connect to a TV that supports 480p or higher.
- Set "Component Video Resolution" to "480p", "720p" or "1080i". (⇒ 33)
- Set "HDMI Video Mode" to "Off". (⇒ 33) Otherwise, the video is output as 480i.

Optional connections and settings

Using FM/AM outdoor antenna (optional)

Use outdoor antennas if FM/AM radio reception is poor.

- Disconnect the antenna when the unit is not in use.
- Do not use the outdoor antenna during an electrical storm.

FM outdoor antenna

[Using a TV antenna (not included)]

- Disconnect the FM indoor antenna.
- The antenna should be installed by a competent technician.

AM outdoor antenna

[Using a vinyl wire (not included)]

- Run a piece of vinyl wire horizontally across a window or other convenient location.

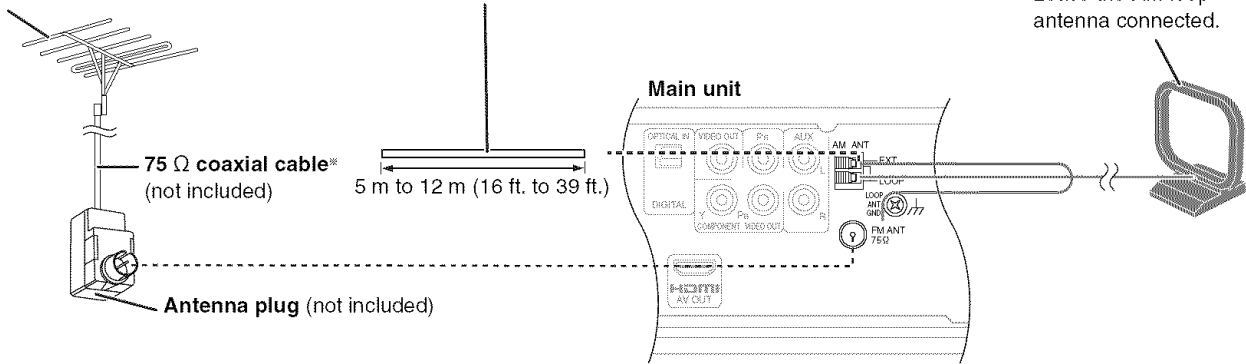

* Rework your outdoor antenna's 75 Ω coaxial cable as follows.

<p>1 Remove a piece of the outer vinyl insulator.</p>	<p>2 Carefully pull the tabs apart to remove the cover.</p>	<p>3 Install the coaxial cable. Clamp the cable conductor, and wind it on so that it does not contact anything else.</p> <p>Clamp with pliers</p>	<p>4 Attach the cover.</p>
--	--	--	-----------------------------------

Connection to an amplifier via the SURROUND and SURROUND BACK terminals

You can enjoy 7.1ch surround sound by connecting an amplifier using audio cable via the SURROUND and SURROUND BACK terminals.

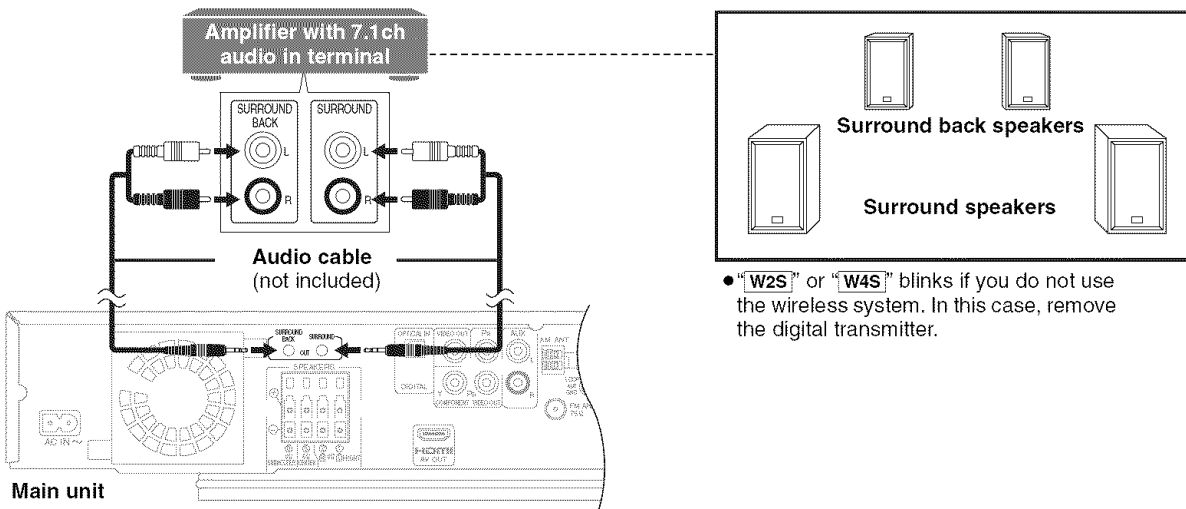

- "W2S" or "W4S" blinks if you do not use the wireless system. In this case, remove the digital transmitter.

Frequently asked questions

Setup

Page

Can I connect other speakers?	<ul style="list-style-type: none"> Speakers other than those supplied cannot be used. This system achieves ideal audio properties through the combination of the main unit and the supplied speakers. Using other speakers may damage the system and will not produce correct audio characteristics (e.g., no bass sounds). 	—
What equipment is necessary to play 7.1-channel surround sound?	<ul style="list-style-type: none"> You can enjoy 7.1-channel surround sound when you use the optional Panasonic wireless accessory SH-FX67 and speaker system SB-HS100A. Refer to the relevant operating instructions for details. 	—
My TV has a VIDEO IN terminal, COMPONENT VIDEO IN terminals and HDMI IN terminal. Which should I connect with?	<ul style="list-style-type: none"> The different levels of picture quality input are listed below in order from highest to lowest. HDMI IN → COMPONENT VIDEO IN → VIDEO IN. However, it will take longer for the picture output to start up when this unit is connected with the HDMI IN terminal. 	—

Disc

Can I play BD-Video and DVD-Video bought in another country?	<ul style="list-style-type: none"> You can play them if the video standard is NTSC, however, you cannot play: <ul style="list-style-type: none"> BD-Video discs that do not include region "A". DVD-Video discs that do not include region "1" or "ALL". Refer to the disc's jacket for more information. 	Cover
Can BD-Video/DVD-Video that does not have a region code/number be played?	<ul style="list-style-type: none"> The region management information for BD-Video/DVD-Video indicates that the disc conforms to industry standards. You cannot play discs that do not conform to industry standards or do not have a region code or number. 	—
Please tell me about disc compatibility with this unit.	<ul style="list-style-type: none"> This unit plays BD-Video, DVD-Video, CD, BD-RE (BD-RE Recording Format/JPEG), BD-R (BD-R Recording Format), DVD-RAM (DVD Video Recording format/AVCHD format/JPEG), DVD-R/RW (DVD-Video format/DVD Video Recording format/AVCHD format), DVD-R DL (DVD-Video format/DVD Video Recording format/AVCHD format), +R, +RW and +R DL. This unit also plays CD-R/RW discs which have been recorded in one of the following standards: CD-DA, MP3 and JPEG. Close the session after recording. You cannot write to a disc with this unit. 	12 12, 13 —

SD card

What kinds of operations are available on the SD card slot on this unit?	<ul style="list-style-type: none"> The following operations are available. <ul style="list-style-type: none"> Playback JPEG data recorded with a digital camera, etc. Playback AVCHD motion pictures recorded with Panasonic High Definition Video Camera If a BD-Video disc supporting this function is used, it is possible to copy secondary video recorded on the disc to the card and play it back together with the images on the disc. (Virtual package) 	22 14 24
What kinds of cards can be used?	<ul style="list-style-type: none"> SD Memory Cards (from 8 MB to 2 GB), SDHC Memory Cards (from 4 GB to 16 GB), miniSD Cards*, and microSD Cards* can be used. * A miniSD Card and a microSD Card must be used in the attached adaptor. Please confirm the latest information on the following website. http://panasonic.co.jp/pavc/global/cs (This site is in English only.) BD-V To play the virtual package, it is recommended that you use a card that supports SD Speed Class Rating Class 2 and has 256 MB or more free space. 	12 —

Language code list

Enter the code with the numbered buttons.

Abkhazian: 6566	Chinese: 9072	Hausa: 7265	Lithuanian: 7684	Romanian: 8279	Telugu: 8469
Afar: 6565	Corsican: 6779	Hebrew: 7387	Macedonian: 7775	Russian: 8285	Thai: 8472
Afrikaans: 6570	Croatian: 7282	Hindi: 7273	Malagasy: 7771	Samoan: 8377	Tibetan: 6679
Albanian: 8381	Czech: 6783	Hungarian: 7285	Malay: 7783	Sanskrit: 8365	Tigrinya: 8473
Ameharic: 6577	Danish: 6865	Icelandic: 7383	Malayalam: 7776	Scots Gaelic: 7168	Tonga: 8479
Arabic: 6582	Dutch: 7876	Indonesian: 7378	Maltese: 7784	Serbian: 8382	Turkish: 8482
Armenian: 7289	English: 6978	Interlingua: 7365	Maori: 7773	Serbo-Croatian: 8372	Turkmen: 8475
Assamese: 6583	Esperanto: 6979	Irish: 7165	Marathi: 7782	Shona: 8378	Twi: 8487
Aymara: 6589	Estonian: 6984	Italian: 7384	Moldavian: 7779	Sindhi: 8368	Ukrainian: 8575
Azerbaijani: 6590	Faroese: 7079	Japanese: 7465	Mongolian: 7778	Singhalese: 8373	Urdu: 8582
Bashkir: 6665	Fiji: 7074	Javanese: 7487	Nauru: 7865	Slovak: 8375	Uzbek: 8590
Basque: 6985	Finnish: 7073	Kannada: 7578	Nepali: 7869	Slovenian: 8376	Vietnamese: 8673
Bengali, Bangla: 6678	French: 7082	Kashmiri: 7583	Norwegian: 7879	Somali: 8379	Volapük: 8679
Bhutani: 6890	Frisian: 7089	Kazakh: 7575	Oriya: 7982	Spanish: 6983	Welsh: 6789
Bihari: 6672	Galician: 7176	Kirghiz: 7589	Pashto, Pushto: 8083	Sundanese: 8385	Wolof: 8779
Breton: 6682	Georgian: 7565	Korean: 7579	Persian: 7065	Swahili: 8387	Xhosa: 8872
Bulgarian: 6671	German: 6869	Kurdish: 7585	Polish: 8076	Swedish: 8386	Yiddish: 7473
Burmese: 7789	Greek: 6976	Laotian: 7679	Portuguese: 8084	Tagalog: 8476	Yoruba: 8979
Byelorussian: 6669	Greenlandic: 7576	Latin: 7665	Punjabi: 8065	Tajik: 8471	Zulu: 9085
Cambodian: 7577	Guarani: 7178	Latvian, Lettish: 7686	Quechua: 8185	Tamil: 8465	
Catalan: 6765	Gujarati: 7185	Lingala: 7678	Rhaeto-Romance: 8277	Tatar: 8484	

Messages

The following messages or service numbers appear on the TV or unit's display when something unusual is detected during startup and use.

On the TV		Page
Cannot play.	• You inserted an incompatible disc (Discs recorded in PAL video, etc.).	12, 13
Cannot display on this unit.	• You tried to play a non-compatible image. • Confirm "SD" on the unit's display is not blinking and re-insert the card.	13 —
No disc	• The disc may be upside down.	—
This disc is incompatible.	• You inserted an incompatible disc.	12, 13
⊘ This operation is currently disabled.	• The operation is prohibited by the unit or disc.	—

On the unit's display

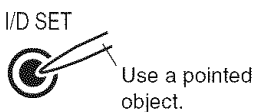
ERROR	• Incorrect operation performed. Read the instructions and try again.	—
F99	• The unit fails to operate properly. Press [POWER ⏻/⏻] on the main unit to switch the unit to standby for 3 seconds. Now press [POWER ⏻/⏻] on the main unit again to turn the unit on.	—
HDMI ONLY	• Some BD-Video discs can only be output with HDMI.	—
No PLAY	• There is a viewing restriction on a BD-Video or DVD-Video.	32
No READ	• The disc is dirty or badly scratched. The unit cannot play.	—
PLEASE WAIT	• Displayed when the unit is started and turned off. This is not a malfunction. • The unit is carrying out its recovery process. You cannot operate the unit while "PLEASE WAIT" is displayed.	— —
SET □ (“□” stands for a number.)	• The remote control and main unit are using different codes. Change the code on the remote control.  Press and hold [OK] and the indicated number button at the same time for more than 5 seconds.	42
UNFORMAT	• You inserted an unformatted DVD-RAM, DVD-RW, +RW, an unused +R, +R DL or DVD-RW (DVD-Video format).	—
UNSUPPORT	• You have inserted a disc the unit cannot play.	12, 13
U59	• The unit is hot. The unit switches to standby for safety reasons. Wait for about 30 minutes until the message disappears. Select a position with good ventilation when installing the unit. Do not block the cooling fan on the rear of the unit.	—
"W2S" or "W4S" is flashing.	<ul style="list-style-type: none"> • There is no link between the main unit and the wireless system. Check that the wireless system is plugged into the AC outlet and is turned on. • Ensure that the digital transmitter is fully inserted into the slot of the main unit. • Perform the steps below. <ol style="list-style-type: none"> 1 While pressing the [▶▶/▶▶] on the main unit, press the numbered button [3] on the remote control until "P" lights in the main unit's display. <ul style="list-style-type: none"> • The indicator on the wireless system turns green. 2 While "P" is displayed, press [I/D SET] on the rear of the wireless system. <ul style="list-style-type: none"> • If "P" goes off before you press [I/D SET], repeat step 1 and then continue the procedure. 3 While pressing [▶▶/▶▶] on the main unit, press the numbered button [3] on the remote control. <ul style="list-style-type: none"> • "W2S" or "W4S" lights on the main unit. 4 Turn off and on the wireless system. <ul style="list-style-type: none"> • Make sure the indicator on the wireless system lights up green. 	8 6 —
U72 U73	• The HDMI connection acts unusually. <ul style="list-style-type: none"> – The connected equipment is not HDMI compatible. – Please use HDMI cables that have the HDMI logo (as shown on the cover). – The HDMI cable is damaged. 	—
H□□ or F□□	<ul style="list-style-type: none"> • Check and correct the speaker cable connections. • There is something unusual. (The service number displayed after H and F depends on the unit's condition.) • Check the unit using the troubleshooting guide. If the service number does not disappear, do the following. <ol style="list-style-type: none"> 1 Disconnect the plug from the AC outlet, wait a few seconds, then reconnect it. 2 Press [POWER ⏻/⏻] to turn the power on. (The unit may be fixed.) If the service number does not disappear despite doing the above, request service from the dealer. Inform the dealer of the service number when requesting service. 	6 — 39–42
NOT CONDITIONAL NO SURROUND SPEAKER	<ul style="list-style-type: none"> • 7.1ch Virtual Surround is available only when playing 6ch sources or above. • 7.1ch Virtual Surround is available only when speaker setting is set to 5.1-channel. 	27 27, 33, 34







Troubleshooting guide

Before requesting service, make the following checks. If you are in doubt about some of the check points, or if the solutions indicated in the chart do not solve the problem, refer to "Customer Services Directory" on page 46 if you reside in the U.S.A., or refer to "Product information" on page 47 if you reside in Canada.

The following do not indicate a problem with this unit:

- Regular disc rotating sounds.
- Image disturbance during search.









To reset this unit

		Page
To restore the unit if it freezes due to one of the safety devices being activated	<ul style="list-style-type: none"> • Press and hold [POWER ] on the main unit for 10 seconds. (The settings remain unchanged.) 	—
To return all settings other than some settings to the factory preset	<ul style="list-style-type: none"> • Select "Yes" in "Restore Default Settings" in the Setup menu. This returns all values in the Setup menu and the on-screen menu, except for "Remote Control Code", "On-screen Language", "DVD-Video Ratings", "BD-Video Ratings" and "Speaker" to the default settings. 	32
To return to the factory preset	<ul style="list-style-type: none"> • Reset the unit as follows: <ol style="list-style-type: none"> 1 Press [POWER ] on the unit to turn off the unit. 2 Press and hold [] / [], [] and [ OPEN/CLOSE] on the unit at the same time for more than 5 seconds until "PLEASE WAIT" is displayed on the unit. 3 The power is turned off automatically. 	—

Power

No power.	<ul style="list-style-type: none"> • Insert the AC power supply cord securely into a known active AC outlet. 	8
The unit switches to standby mode.	<ul style="list-style-type: none"> • This is a power saving feature. It can be changed if desired using "Off Timer" in the Setup menu. • When the time set for the sleep timer has passed, the power will be turned off. • One of the unit's safety devices is activated. Press [POWER ] on the main unit to turn the unit on. 	32 16 —

Operation

The remote control doesn't work properly.	<ul style="list-style-type: none"> • The remote control and main unit are using different codes. Change the code on the remote control. Press and hold [OK] and the indicated number button at the same time for more than 5 seconds. • The batteries are depleted. Replace them with new ones. • You are not pointing the remote control at the main unit's remote control signal sensor during operation. • Colored glass may obstruct the signal reception/transmission. • Don't place the signal sensor in direct sunlight or in areas that may be subject to sunlight exposure. • It may be necessary to set the code on the remote control again after changing the batteries. 	 42 3 3 — — 42
The unit is on but cannot be operated.	<ul style="list-style-type: none"> • Confirm the correct source is selected. • Some operations may be prohibited by the disc. • The unit is hot ("U59" appears on the display). Wait for "U59" to disappear. • One of the unit's safety devices may have been activated. Reset the unit as follows: <ol style="list-style-type: none"> 1 Press [POWER ] on the main unit to switch the unit to standby. If the unit doesn't switch to standby, press and hold [POWER ] on the main unit for about 10 seconds. Alternatively, disconnect the AC power supply cord, wait one minute, then reconnect it. 2 Press [POWER ] on the main unit to switch it on. If the unit still cannot be operated, consult the dealer. • Condensation has formed: Wait 1 to 2 hours for it to evaporate. 	10 — 38 — —
Play fails to start even when [] (PLAY) is pressed. Play starts but then stops immediately.	<ul style="list-style-type: none"> • Insert the disc correctly with the label facing up. • The disc is dirty. • You tried to play a blank disc or unplayable disc on this unit. • The producers of the disc can control how discs are played. So you may not always be able to control play as described in these operating instructions. Read the disc's instructions carefully. 	14 42 12, 13 —
Cannot eject disc.	<ul style="list-style-type: none"> • The unit may have a problem. While the unit is off, press and hold [] / [] and [ OPEN/CLOSE] on the main unit at the same time for about 5 seconds. Remove the disc and consult the dealer. 	—
Startup is slow. When the unit is turned on, audio and video output takes a long time.	<ul style="list-style-type: none"> • Startup takes time in the following situations. <ul style="list-style-type: none"> – Immediately after a power failure or the AC power supply cord is connected. – When the unit is connected with an HDMI cable. 	—
Cannot set "On" in "BD-Video 24p Output".	<ul style="list-style-type: none"> • Only when the unit is connected to the HDMI terminal of a TV supporting 24p can you select "On". 	33

Displays

The display is dim.	<ul style="list-style-type: none"> • Change "FL Display" in the Setup menu. 	33
The elapsed time displayed is actually less than the playtime.	<ul style="list-style-type: none"> • The displayed play time is converted from the number of frames at 29.97 frames (equal to 0.999 seconds) to one second. There will be a slight difference between the time displayed and the actual elapsed time (e.g., actual one-hour elapsed time may display as approximately 59 minutes 56 seconds). 	—

Troubleshooting guide

TV screen and video		Page
The images from this unit do not appear on the TV.	<ul style="list-style-type: none"> Make sure that the TV is connected to the VIDEO OUT terminal, COMPONENT VIDEO OUT terminals or HDMI AV OUT terminal on this unit. Make sure that the TV's input setting (e.g., VIDEO 1) is correct. 	7, 35
Picture is distorted.	<ul style="list-style-type: none"> To output video from a device connected with an HDMI cable, set "HDMI Video Mode" to "On" in the Setup menu. 	33
	<ul style="list-style-type: none"> If "BD-Video 24p Output" is turned "On" when the unit is connected to a TV through any terminal other than HDMI, images may not display properly. In this case, turn "BD-Video 24p Output" to "Off". 	33
	<ul style="list-style-type: none"> When "BD-Video 24p Output" is set to "On", HDMI authentication takes place where 24p images switch to other images, and a black screen is displayed. 	33
	<ul style="list-style-type: none"> When you use the HDMI AV OUT terminal for video output, press and hold [▶] (PLAY) and [■] simultaneously on the unit for more than 5 seconds to shift the mode to one more compatible with HDMI equipment. 	—
	<ul style="list-style-type: none"> Picture may not be seen when more than 3 devices are connected with HDMI cables. Reduce the number of connected devices. 	—
	<ul style="list-style-type: none"> An incorrect resolution is selected in "Component Video Resolution", when the TV is connected to COMPONENT VIDEO OUT terminals. While stopped, press and hold [▶] (PLAY) and [■] on the main unit at the same time for more than 5 seconds to cancel this setting. Set the item again. 	33
	<ul style="list-style-type: none"> Mobile telephone chargers can cause some disturbance. If you are using an indoor TV antenna, change to an outdoor antenna. The TV antenna wire is too close to the unit. Move it away from the unit. 	—
The screen changes automatically.	<ul style="list-style-type: none"> When the "Screen Saver Function" in the Setup menu is set to "On", the display may return to the screen saver mode automatically if there is no operation for 10 minutes or more. 	33
Video is not output in high definition.	<ul style="list-style-type: none"> High definition video cannot be output through the VIDEO OUT terminal. 	—
	<ul style="list-style-type: none"> Confirm that the "HDMI Video Mode", "HDMI Resolution", and "Component Video Resolution" in the Setup menu are set properly. 	33
	<ul style="list-style-type: none"> Depending on the BD-Video, output from the COMPONENT VIDEO OUT terminals may be restricted to 480p. 	—
The Setup menu cannot be accessed.	<ul style="list-style-type: none"> Select "BD/DVD/CD" or "SD" as the source. 	—
Status messages do not appear.	<ul style="list-style-type: none"> Select "Automatic" in "Status Messages" in the Setup menu. 	33
The 4:3 aspect ratio picture expands left and right.	<ul style="list-style-type: none"> Use the TV to change the aspect. Refer to your TV's operating instructions. When using an HDMI cable, set "TV Aspect" to "16:9". When using a component video cable, set "Progressive" to "Off". If the situation is not restored after that, set "TV Aspect" to "4:3 Pan & Scan". 	— 33 31, 33
Screen size is wrong.	<ul style="list-style-type: none"> Turn "3D NR" or "Integrated NR" off if it is on. 	31
There is a lot of after-image when playing video.	<ul style="list-style-type: none"> Turn "3D NR" or "Integrated NR" off if it is on. 	31
	<ul style="list-style-type: none"> When you use the COMPONENT VIDEO OUT terminal for video output, set "Progressive" of "Video" menu on the on-screen menu to "Off". This problem is caused by the editing method or material used on DVD-Video, but should be corrected if you use interlace output. When you use the HDMI AV OUT terminal for video output, follow the steps below for setting. <ol style="list-style-type: none"> Connect this unit to the TV with any cable except the HDMI cable. When you connect with the Component Video cable, set "HDMI Video Mode" to "Off" and "Component Video Resolution" to "480i" in the Setup menu. 	31 7, 35 33
When playing DVD-Video using progressive output, one part of the picture momentarily appears to be doubled up.	<ul style="list-style-type: none"> When you use the COMPONENT VIDEO OUT terminal for video output, set "Progressive" of "Video" menu on the on-screen menu to "Off". This problem is caused by the editing method or material used on DVD-Video, but should be corrected if you use interlace output. When you use the HDMI AV OUT terminal for video output, follow the steps below for setting. <ol style="list-style-type: none"> Connect this unit to the TV with any cable except the HDMI cable. When you connect with the Component Video cable, set "HDMI Video Mode" to "Off" and "Component Video Resolution" to "480i" in the Setup menu. 	31 7, 35 33
There is no apparent change in picture quality when adjusted with the Video menu in the on-screen menu.	<ul style="list-style-type: none"> The effect is less perceivable with some types of video. 	—
The masked-off area is masked in gray.	<ul style="list-style-type: none"> If the "Screen Saver Function" in the Setup menu is set to "Off", the masked-off area is displayed in black. 	33
Sound		
No sound. Low volume. Distorted sound. Cannot hear the desired audio type.	<ul style="list-style-type: none"> Turn the volume up. Turn the muting off. 	14-15 16
	<ul style="list-style-type: none"> Check connections to speakers and other equipment. 	6-8, 35-36
	<ul style="list-style-type: none"> Press [>, < SELECT] to select the corresponding source. 	10
	<ul style="list-style-type: none"> Press [AUDIO] to select the audio. 	16
	<ul style="list-style-type: none"> Ensure the speaker settings for your speakers are correct. 	33, 34
	<ul style="list-style-type: none"> To output audio from a device connected with an HDMI cable, set "HDMI Audio Output" to "On" in the Setup menu. 	33
	<ul style="list-style-type: none"> When "BD-Video Secondary Audio" is set to "On", Dolby TrueHD, Dolby Digital Plus, DTS-HD Master Audio and DTS-HD High Resolution Audio are output as Dolby Digital. 	33
Humming is heard during play.	<ul style="list-style-type: none"> Audio may not be heard when more than 3 devices are connected with HDMI cables. Reduce the number of connected devices. Ensure that surround selector at the rear of the wireless system is set to the center position. 	— 6
	<ul style="list-style-type: none"> An AC power supply cord or fluorescent light is near the main unit or wireless system. Keep other appliances and cables away from the main unit and wireless system. 	—
No surround sound.	<ul style="list-style-type: none"> Press [DOLBY IIX] to turn on Dolby Pro Logic IIX/Dolby Pro Logic II. 	27
	<ul style="list-style-type: none"> Press [NEO:6] to turn on DTS NEO:6. 	27
Cannot switch audio.	<ul style="list-style-type: none"> There are discs for which audio cannot be changed because of how the disc was created. 	—

Card		Page
The capacity of the SD card decreased.	<ul style="list-style-type: none"> When a BD-Video that supports the virtual package is used, and an SD card is in the slot, data may be written to the SD card. Erase the data by using "BD-Video Data Erase", format the card or use a new card. 	24
MPEG-2 motion pictures and music on an SD card cannot be played.	<ul style="list-style-type: none"> Data that can be played from an SD card are AVCHD and JPEG data. 	12
The contents of the card cannot be read.	<ul style="list-style-type: none"> The card is not compatible or the contents on the card may be damaged. Turn off and then turn on the unit again. 	12

iPod operation

Cannot charge or operate.	<ul style="list-style-type: none"> Check that the iPod is connected firmly. The battery of the iPod is depleted. Charge the iPod, and then operate again. 	20
Cannot display iPod videos/photos on the TV.	<ul style="list-style-type: none"> Make sure that TV is connected to the VIDEO OUT terminal on this unit. Operate the iPod menu to make the appropriate video/photo output settings for your TV. (Refer to operating instructions for your iPod.) 	7

Radio

Distorted sound or noise is heard. "ST" flickers or does not light.	<ul style="list-style-type: none"> Adjust the position of the FM or AM antenna. Use an outdoor antenna. 	36
A beat sound is heard.	<ul style="list-style-type: none"> Turn the TV off or move it away from the unit. 	—
A low hum is heard during AM broadcasts.	<ul style="list-style-type: none"> Separate the antenna from other cables. 	—

Wireless system

No sound.	<ul style="list-style-type: none"> Ensure that the digital transmitter is fully inserted into the slot of the main unit. Ensure that the wireless system is plugged into the house hold AC outlet and is turned on. Then, check that "W2S" or "W4S" is displayed on the main unit's display. Ensure that surround selector at the rear of the wireless system is set to the center position. Perform the steps below. <ol style="list-style-type: none"> While pressing the [▶▶ ▶▶] on the main unit, press the numbered button [3] on the remote control until "P" lights in the main unit's display. <ul style="list-style-type: none"> The indicator on the wireless system turns green. While "P" is displayed, press [I/D SET] on the rear of the wireless system. <ul style="list-style-type: none"> If "P" goes off before you press [I/D SET], repeat step 1 and then continue the procedure. While pressing [▶▶ ▶▶] on the main unit, press the numbered button [3] on the remote control. <ul style="list-style-type: none"> "W2S" or "W4S" lights on the main unit. Turn off and on the wireless system. <ul style="list-style-type: none"> Make sure the indicator on the wireless system lights up green. 	6 8, 9 6 —
The indicator on the wireless system keeps flashing between red and green.	<ul style="list-style-type: none"> There is a power supply problem. Consult the dealer. 	—

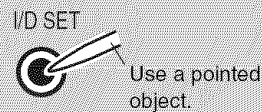

Other difficulties with playback

Audio and video momentarily pause.	<ul style="list-style-type: none"> This occurs between playlist chapters or scenes (AVCHD). When playing a title recorded on both layers, the unit automatically switches between layers and plays the title in the same way as a normal program. However, video and audio may momentarily cut out when the unit is switching layers. 	—
BD-Video or DVD-Video is not played.	<ul style="list-style-type: none"> Ensure the disc is for the correct BD-Video region code or DVD-Video region number, and is not defective. You have set a ratings level to limit BD-Video or DVD-Video play. Change this setting. Some BD-Video can only be output with HDMI. 	Cover 32 —
Picture-in-picture is not played with BD-Video.	<ul style="list-style-type: none"> Confirm whether the disc supports picture-in-picture. 	—
The virtual package is not played with BD-Video.	<ul style="list-style-type: none"> Confirm whether the disc supports the virtual package. The inserted SD card does not have sufficient available capacity. The SD card is write-protected. Sub contents copied to an SD card are provided by the disc producer as a part of the BD-Video content. Even if you record images and audio onto an SD card, it cannot be played as a virtual package. 	24 — 12 24
Alternative soundtrack and subtitles cannot be selected.	<ul style="list-style-type: none"> The languages are not recorded on the disc. You may not be able to use the on-screen menu to change the soundtrack and subtitles on some discs. Use the disc's menus to make changes. 	— 14, 24
No subtitles.	<ul style="list-style-type: none"> Subtitles are not recorded on the disc. Turn the subtitles on. Set "Subtitle" on the on-screen menu to "On". When progressive output is on, closed captions cannot be displayed. 	— 30 —
The subtitles overlap closed captions recorded on discs.	<ul style="list-style-type: none"> Turn off the subtitles or turn off the closed caption setting on the TV. 	30
Angle cannot be changed.	<ul style="list-style-type: none"> Angles can only be changed during scenes where different angles are recorded. 	—
The resume play function does not work.	<ul style="list-style-type: none"> Memorized positions are canceled when <ul style="list-style-type: none"> pressing [■] several times. opening the disc tray. The resume play function may not work depending on the disc. 	—

Troubleshooting guide

When other Panasonic products respond to this remote control

Change the remote control code on the main unit and the remote control (the two must match) if you place other Panasonic products close together.

- ① Press [BD/SD] to select "BD/DVD/CD" or "SD".
- ② While stopped, press [SETUP].
- ③ Press [▲, ▼] to select "Setup" and press [OK].
- ④ Press [▲, ▼] to select "Remote Control Code" and press [OK].
- ⑤ Press [▲, ▼] to select the code (1 or 2) and press [OK].
- ⑥ To change the code on the remote control
While pressing [OK], press and hold the numbered button ([1] or [2]) for more than 5 seconds.
- ⑦ Press [OK].

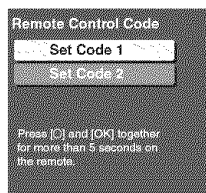

NOTE When the following indicator appears on the unit's display and you are unable to operate the unit



The unit's remote control code
Press and hold [OK] and the indicated number button at the same time for more than 5 seconds.

Disc and card handling

Clean discs

DO **DO NOT**



Wipe with a damp cloth and then wipe dry.

Disc and card handling precautions

- Handle discs by the edges to avoid inadvertent scratches or fingerprints on the disc.
- Do not attach labels or stickers to discs (This may cause disc warping, rendering it unusable).
- Do not write on the label side with a ball-point pen or other writing instrument.
- Do not use record cleaning sprays, benzene, thinner, static electricity prevention liquids or any other solvent.
- Do not use scratch-proof protectors or covers.
- Clean any dust, water, or foreign matter from the terminals on the rear side of the card.
- Do not use the following discs:
 - Discs with exposed adhesive from removed stickers or labels (rented discs etc).
 - Discs that are badly warped or cracked.
 - Irregularly shaped discs, such as heart shapes.

Maintenance

Clean this unit with a soft, dry cloth

- Never use alcohol, paint thinner or benzene to clean this unit.
- Before using chemically treated cloth, read the instructions that came with the cloth carefully.

Observe the following points to ensure continued listening and viewing pleasure.

Dust and dirt may adhere to the unit's lens over time, making it impossible to play discs.

Use the lens cleaner (not included) about once every year, depending on frequency of use and the operating environment. Carefully read the lens cleaner's instructions before use.

Lens cleaner: RP-CL720PP

- This lens cleaner is sold as specific for DIGA, but can be used without problem on this unit as well.

Java and all Java-based trademarks and logos are trademarks or registered trademarks of Sun Microsystems, Inc. in the United States and other countries.

Manufactured under license from Dolby Laboratories. Dolby, Pro Logic, and the double-D symbol are trademarks of Dolby Laboratories.

"DTS" is a registered trademark of DTS, Inc. and "DTS-HD Master Audio" is a trademark of DTS, Inc.

U.S. Patent Nos. 6,836,549; 6,381,747; 7,050,698; 6,516,132; and 5,583,936.

This product incorporates copyright protection technology that is protected by U.S. patents and other intellectual property rights. Use of this copyright protection technology must be authorized by Macrovision, and is intended for home and other limited viewing uses only unless otherwise authorized by Macrovision. Reverse engineering or disassembly is prohibited.

HDMI, the HDMI logo and High-Definition Multimedia Interface are trademarks or registered trademarks of HDMI Licensing LLC.

This product is licensed under the AVC patent portfolio license and VC-1 patent portfolio license for the personal and non-commercial use of a consumer to (i) encode video in compliance with the AVC Standard and VC-1 Standard ("AVC/VC-1 Video") and/or (ii) decode AVC/VC-1 Video that was encoded by a consumer engaged in a personal and non-commercial activity and/or was obtained from a video provider licensed to provide AVC/VC-1 Video. No license is granted or shall be implied for any other use. Additional information may be obtained from MPEG LA, LLC. See <http://www.mpegla.com>.

HDAVI Control™ is a trademark of Matsushita Electric Industrial Co., Ltd.

VIERA Link™ is a trademark of Matsushita Electric Industrial Co., Ltd.

EZ Sync™ is a trademark of Matsushita Electric Industrial Co., Ltd.

"AVCHD" and the "AVCHD" logo are trademarks of Matsushita Electric Industrial Co., Ltd. and Sony Corporation.

SDHC Logo is a trademark.

Portions of this product are protected under copyright law and are provided under license by ARIS/SOLANA/4C.

iPod is a trademark of Apple Inc., registered in the U.S. and other countries.

Glossary

AVCHD

AVCHD is a new format (standard) for high definition video cameras that can be used to record and play high-resolution HD images.

BD-J

Some BD-Video discs contain Java applications, and these applications are called BD-J. You can enjoy various interactive features in addition to playing normal video.

Bitstream

This is the digital form of multi-channel audio data (e.g., 5.1-channel) before it is decoded into its various channels.

Dolby Digital

This is a method of coding digital signals developed by Dolby Laboratories. Apart from stereo (2-channel) audio, these signals can also be multi-channel audio.

Dolby Digital Surround EX

This is the digital surround system developed by Dolby Laboratories. Dolby Digital Surround EX adds a surround back channel to the traditional 5.1-channel format of Dolby Digital. This creates a sound with greater presence.

Dolby Digital Plus

Multi-channel audio and higher audio quality is made possible using Dolby Digital Plus. BD-Video supports up to 7.1-channel output.

Dolby Pro Logic II

Dolby Pro Logic II enables you to play stereo sources on 5.1-channel.

Dolby Pro Logic IIx

Dolby Pro Logic IIx enables you to play stereo and 5.1-channel sources on 7.1-channel.

Dolby TrueHD

Dolby TrueHD is a very high quality audio format that reproduces the studio master audio. BD-Video supports up to 7.1-channel output.

DTS (Digital Theater Systems)

This surround system is used in many movie theaters. There is good separation between the channels, so realistic sound effects are possible.

DTS-ES

DTS-ES adds a surround back channel to the traditional 5.1-channel format of DTS. This creates a sound with greater presence.

DTS-HD

DTS-HD is a high-quality, sophisticated audio format used in movie theaters. Previous DTS Digital Surround-compatible equipment can play DTS-HD as DTS Digital Surround audio. BD-Video supports up to 7.1-channel output.

DTS NEO:6

DTS NEO:6 enables you to play stereo and 5.1-channel sources on 6.1-channel.

DTS 96/24

DTS 96/24 provides 96 kHz sound at up to 24 bits. The 96 kHz/24 bit high frequency sounds are played through multiple channels.

Dynamic range

Dynamic range is the difference between the lowest level of sound that can be heard above the noise of the equipment and the highest level of sound before distortion occurs. Dynamic range compression means reducing the gap between the loudest and softest sounds. This means you can listen at low volumes but still hear dialog clearly.

Film and video

DVD-Video are recorded using either film or video. This unit can determine which type has been used, then uses the most suitable method of progressive output.

Film: Recorded at 24 frames per second. (Recorded at 30 frames per second as well). Generally appropriate for motion picture films.

Video: Recorded at 30 frames/60 fields per second. Generally appropriate for TV drama programs or animation.

Final Standard Profile (FSP)

This is a BD-Video [BD-ROM version 2 (Profile 1 version 1.1)] that supports the new functions such as Picture-in-picture, Secondary Audio, and Virtual Package, etc.

Frames and fields

Frames refer to the single images that constitute the video you see on your TV. Each frame consists of two fields.

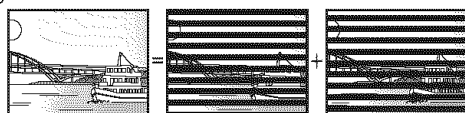

Frame

Field

Field

- A frame still shows two fields, so there may be some blurring, but picture quality is generally better.
- A field still shows less picture information so it may be rougher, but there is no blurring.

HDMI (High-Definition Multimedia Interface)

HDMI is a digital interface for consumer electronic products. Unlike conventional connections, it transmits uncompressed digital video and audio signals on a single cable.

JPEG (Joint Photographic Experts Group)

This is a system used for compressing/decoding color still pictures. If you select JPEG as the storage system on digital cameras, etc., the data will be compressed to 1/10–1/100 of its original size. The benefit of JPEG is less deterioration in picture quality considering the degree of compression.

Local storage

This storage area is used as a destination for sub contents for playing virtual packages on BD-Video.

LPCM (Linear PCM)

These are uncompressed digital signals, similar to those found on CDs.

MP3 (MPEG Audio Layer 3)

An audio compression method that compresses audio to approximately one tenth of its size without any significant loss of audio quality.

Pan&Scan/Letterbox

In general, DVD-Video are produced with the intention that they be viewed on a widescreen TV (16:9 aspect ratio), so images often don't fit regular (4:3 aspect ratio) TVs. Two styles of picture, "Pan & Scan" and "Letterbox", deal with this problem.

Pan&Scan: The sides are cut off so the picture fills the screen.

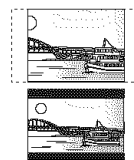

Letterbox: Black bands appear at the top and bottom of the picture so the picture itself appears in an aspect ratio of 16:9.

Picture-in-picture

This is a new function of BD-Video that plays the primary video and secondary video simultaneously. For instance, the function is capable of playing the original movie as the primary video while playing video commentary from the film director on a small screen as a secondary video.

Progressive/Interlace

The video signal standard of NTSC has 480 interlaced (i) scan lines, whereas progressive (p) scanning uses twice the number of scan lines, and this is referred to as 480p. Using progressive output, you can enjoy watching high resolution video.

Sampling frequency

Sampling is the process of converting the heights of sound wave (analog signal) samples taken at set periods into digits (digital encoding). Sampling frequency is the number of samples taken per second, so larger numbers mean more faithful reproduction of the original sound.

Virtual package

Some BD-Video discs copy data to other media (local storage) and then play the secondary video, secondary audio, and subtitles (sub contents) simultaneously.

These functions are called virtual packages.

Sub contents are automatically recorded to other media from the disc prior to playing the virtual package. The playback methods vary depending on discs.

1080i (1125i)

In one high definition image, 1080 (1125) alternating scan lines pass to create an interlaced image. Because 1080i (1125i) more than doubles current TV broadcasts of 480i, the detail is much clearer and creates a more realistic and rich image.

1080p (1125p)

In one high definition image, 1080 (1125) scan lines pass at the same time to create a progressive image. Since progressive video does not alternate scan lines like interlace, there is a minimal amount of screen flicker.

24p

This is a progressive image recorded at a rate of 24 frames per second.

720p (750p)

In one high definition image, 720 (750) scan lines pass at the same time to create a progressive image. Since progressive video does not alternate scan lines like interlace, there is a minimal amount of screen flicker.

Specifications

AMPLIFIER SECTION

RMS TTL Power Output	1250 W
Front Ch	250 W per channel (6 Ω), 1 kHz, 10 % THD
Surround Ch	125 W per channel (3 Ω), 1 kHz, 10 % THD
Center Ch	250 W per channel (6 Ω), 1 kHz, 10 % THD
Subwoofer Ch	250 W per channel (6 Ω), 100 Hz, 10 % THD

FTC TTL Power Output	472 W
Front Ch	104 W per channel (6 Ω), 120 Hz to 20 kHz, 1.0 % THD
Surround Ch	34 W per channel (3 Ω), 120 Hz to 20 kHz, 1.0 % THD
Center Ch	101 W per channel (6 Ω), 120 Hz to 20 kHz, 1.0 % THD
Subwoofer Ch	95 W per channel (6 Ω), 45 Hz to 120 Hz, 1.0 % THD

Audio Input	
AUX	× 1
Digital Audio Input	
Optical	× 1

FM TUNER SECTION

Frequency range	87.9 to 107.9 MHz (200-kHz step)
	87.5 to 108.0 MHz (100-kHz step)
Antenna terminals	75 Ω (unbalanced)

AM TUNER SECTION

AM Frequency range	520 to 1710 kHz (10-kHz step)
---------------------------	-------------------------------

DISC SECTION

Playable disc:	
BD-Video:	BD-ROM Version 2
BD-RE:	Version 3 (Single Layer, Dual Layer), JPEG*6
BD-R	Version 2 (Single Layer, Dual Layer)
DVD-RAM:	DVD Video Recording format, AVCHD format*7, JPEG*4
DVD-R/DVD-RW/DVD-R DL:	DVD-Video format*1, DVD-Video Recording format, AVCHD format*1,7
+R/+RW/+R DL:	Video*1, AVCHD format*1,7
DVD-Video:	DVD-Video format
CD-Audio:	CD-DA
CD-R/RW:	CD-DA, JPEG*5, MP3

Optical pick-up:	System with 2 lenses
Wave length:	782 nm (CDs)/662 nm (DVDs)/405 nm (BDs)

LASER Specification:

Class 1 LASER Product	
Wave length:	782 nm (CDs)/662 nm (DVDs)/405 nm (BDs)
Laser power:	No hazardous radiation is emitted with the safety protection

SD CARD SECTION

SD card slot:	Output connector (1 system)
SD card:	
	SD Memory Card*2 formatted FAT12, FAT16, FAT32*3: JPEG*4, AVCHD format*7

• Usable capacity will be less (SD Card).

- *1 Finalizing is necessary.
- *2 includes SDHC card
includes miniSD cards (need a miniSD Adaptor)
includes microSD cards (need a microSD Adaptor)
- *3 Does not support long file name
- *4 The total combined maximum number of recognizable picture contents and folders: 3000 picture contents and 300 folders.
- *5 The total combined maximum number of recognizable picture contents and folders: 999 picture contents and 99 folders.
- *6 The total combined maximum number of recognizable picture contents and folders: 9999 picture contents and 300 folders.
- *7 AVCHD format V1.0

VIDEO SECTION

Signal system	NTSC
Video output	
Output level	1.0 Vp-p (75 Ω)
Output connector	Pin jack (1 system)

Component video output	(1080i/720p/480p/480i)
Y output level	1.0 Vp-p (75 Ω)
P _B output level	0.7 Vp-p (75 Ω)
P _R output level	0.7 Vp-p (75 Ω)
Output connector	Pin jack (Y: green, P _B : blue, P _R : red) (1 system)

HDMI AV output	
Output format:	480p (525p)/1080i (1125i)/720p (750p)/1080p (1125p)
Output connector:	Type A (19 pin)
HDMI™ (Deep color)	
• This unit supports "HDAVI Control 3" function.	

SPEAKER SECTION

■ Front speakers SB-HF100

Type	2 way, 3 speaker system (Bass reflex)
Speaker unit(s)	Impedance 6 Ω
1. Woofer	6.5 cm (2 ¹ / ₂ ") Cone type × 2
2. Tweeter	6 cm (2 ³ / ₈ ") Cone type
Input power (IEC)	250 W (Max) *8
Output sound pressure	83 dB/W (1 m)
Frequency range	80 Hz to 25 kHz (– 16 dB)
	93 Hz to 22 kHz (– 10 dB)
Dimensions (W×H×D)	121 mm×328 mm×129 mm (4 ²⁵ / ₃₂ " × 12 ¹⁵ / ₁₆ " × 5 ³ / ₃₂ ")
Mass (Weight)	Approx. 1.7 kg (3.7 lbs)

■ Surround speakers SB-HS100

Type	1 way, 1 speaker system (Bass reflex)
Speaker unit(s)	Impedance 3 Ω
Full range	6.5 cm (2 ¹ / ₂ ") Cone type
Input power (IEC)	125 W (Max) *8
Output sound pressure	80 dB/W (1 m)
Frequency range	82 Hz to 25 kHz (– 16 dB)
	92 Hz to 22 kHz (– 10 dB)
Dimensions (W×H×D)	121 mm×328 mm×129 mm (4 ²⁵ / ₃₂ " × 12 ¹⁵ / ₁₆ " × 5 ³ / ₃₂ ")
Mass (Weight)	Approx. 1.0 kg (2.2 lbs)

■ Center speaker SB-HC100

Type	2 way, 3 speaker system (Bass reflex)
Speaker unit(s)	Impedance 6 Ω
1. Woofer	6.5 cm (2 ¹ / ₂ ") Cone type × 2
2. Tweeter	6 cm (2 ³ / ₈ ") Cone type
Input power (IEC)	250 W (Max) *8
Output sound pressure	83 dB/W (1 m)
Frequency range	80 Hz to 25 kHz (– 16 dB)
	93 Hz to 22 kHz (– 10 dB)
Dimensions (W×H×D)	301 mm×111 mm×134 mm (11 ⁷ / ₈ " × 4 ³ / ₈ " × 5 ³ / ₃₂ ")
Mass (Weight)	Approx. 1.6 kg (3.5 lbs)

■ Subwoofer SB-HW560

Type	1 way, 1 speaker system (Kelton type)
Speaker unit(s)	Impedance 6 Ω
1. Woofer	16 cm (6 ¹ / ₂ ") Cone type
2. Passive Radiator	25 cm (10")
Input power (IEC)	250 W (Max)
Output sound pressure	78 dB/W (1 m)
Frequency range	35 Hz to 200 Hz (– 16 dB)
	40 Hz to 198 Hz (– 10 dB)
Dimensions (W×H×D)	181 mm×361 mm×315 mm (7 ¹ / ₈ " × 14 ⁷ / ₃₂ " × 12 ¹³ / ₃₂ ")
Mass (Weight)	Approx. 4.7 kg (10.4 lbs)

*8 Rating with the low cut filter equipped amplifier.

GENERAL

Power supply	AC 120 V, 60 Hz
iPod Connector	DC OUT 5 V 500 mA MAX
Power consumption	140 W
Dimensions (W×H×D)	
With transmitter	430 mm×96 mm×327 mm (16 ¹⁵ / ₁₆ "×3 ²⁵ / ₃₂ "×12 ⁷ / ₈ ")
Without transmitter	430 mm×90 mm×327 mm (16 ¹⁵ / ₁₆ "×3 ⁹ / ₁₆ "×12 ⁷ / ₈ ")
Mass (Weight)	Approx. 4.1 kg (9.1 lbs)
	(Dimensions and Mass do not include the speakers.)
Operating temperature range	0 °C to +40 °C (+32 °F to +104 °F)
Operating humidity range	35 % to 80 % RH (no condensation)

Power consumption in standby mode	Approx. 0.3 W
-----------------------------------	---------------

WIRELESS SYSTEM AND DIGITAL TRANSMITTER

■ AMPLIFIER SECTION

RMS TTL Power Output	250 W
Surround Ch	125 W per channel (3 Ω), 1 kHz, 10 % THD
FTC TTL Power Output	68 W
Surround Ch	34 W per channel (3 Ω), 120 Hz to 20 kHz, 1 % THD

■ RF SECTION

Wireless module	
Frequency range	2.400 GHz to 2.4835 GHz
No. of channels	3

■ GENERAL

Power supply	AC 120 V, 60 Hz
Power consumption	
Digital transmitter	1.7 W
Wireless system	35 W
Dimensions (W×H×D)	
Digital transmitter	65 mm×52 mm×8.6 mm (2 ⁹ / ₁₆ "×2 ¹ / ₁₆ "×1 ¹¹ / ₃₂ ")
Wireless system	165 mm×90 mm×164 mm (6 ¹ / ₂ "×3 ¹⁷ / ₃₂ "×6 ¹⁵ / ₃₂ ")
Mass (Weight)	
Digital transmitter	0.02 kg (0.04 lbs)
Wireless system	0.720 kg (1.54 lbs)
Operating temperature range	0 °C to +40 °C (+32 °F to +104 °F)
Operating humidity range	20 % to 80 % RH (no condensation)

Power consumption in standby mode	approx. 0.2 W
-----------------------------------	---------------

Note

Specifications are subject to change without notice.

Listening caution



Selecting fine audio equipment such as the unit you've just purchased is only the start of your musical enjoyment. Now it's time to consider how you can maximize the fun and excitement your equipment offers. This manufacturer and the Electronic Industries Association's Consumer Electronics Group want you to get the most out of your equipment by playing it at a safe level. One that lets the sound come through loud and clear without annoying blaring or distortion—and, most importantly, without affecting your sensitive hearing.

We recommend that you avoid prolonged exposure to excessive noise.

Sound can be deceiving. Over time your hearing "comfort level" adapts to higher volumes of sound. So what sounds "normal" can actually be loud and harmful to your hearing.

Guard against this by setting your equipment at a safe level BEFORE your hearing adapts.

To establish a safe level:

- Start your volume control at a low setting.
- Slowly increase the sound until you can hear it comfortably and clearly, and without distortion.

Once you have established a comfortable sound level:

- Set the dial and leave it there.

Taking a minute to do this now will help to prevent hearing damage or loss in the future. After all, we want you listening for a lifetime.

The model number and serial number of this product can be found on either the back or the bottom of the unit. Please note them in the space provided below and keep for future reference.

MODEL NUMBER _____ SA-BT100 _____
SERIAL NUMBER _____

User memo:

DATE OF PURCHASE _____
DEALER NAME _____
DEALER ADDRESS _____
TELEPHONE NUMBER _____

Limited Warranty (ONLY FOR U.S.A.)

Panasonic Consumer Electronics Company,
Division of Panasonic Corporation of North America
One Panasonic Way Secaucus, New Jersey 07094

Panasonic Puerto Rico, Inc.
Ave. 65 de Infantería, Km. 9.5
San Gabriel Industrial Park, Carolina, Puerto Rico 00985

Panasonic Home Theater Limited Warranty

Limited Warranty Coverage

If your product does not work properly because of a defect in materials or workmanship, Panasonic Consumer Electronics Company or Panasonic Puerto Rico, Inc. (collectively referred to as "the warrantor") will, for the length of the period indicated on the chart below, which starts with the date of original purchase ("Limited Warranty period"), at its option either (a) repair your product with new or refurbished parts, or (b) replace it with a new or a refurbished product. The decision to repair or replace will be made by the warrantor.

Product or Part Name	Parts	Labor
Home Theater System	One (1) Year	One (1) Year
Rechargeable Batteries (in exchange for defective item)	Ten (10) Days	Not Applicable

During the "Labor" Limited Warranty period there will be no charge for labor. During the "Parts" warranty period, there will be no charge for parts. You must mail-in your product during the warranty period. If non-rechargeable batteries are included, they are not warranted. This Limited Warranty only applies to products purchased and serviced in the United States or Puerto Rico. This Limited Warranty is extended only to the original purchaser and only covers product purchased as new. A purchase receipt or other proof of original purchase date is required for Limited Warranty service.

For assistance in Puerto Rico call Panasonic Puerto Rico, Inc. (787)-750-4300 or fax (787)-768-2910.

When shipping the unit carefully pack and send it prepaid, adequately insured and preferably in the original carton. Include a letter detailing the complaint and provide a day time phone and/or email address where you can be reached.

IF REPAIR IS NEEDED DURING THE LIMITED WARRANTY PERIOD THE PURCHASER WILL BE REQUIRED TO FURNISH A SALES RECEIPT/PROOF OF PURCHASE INDICATING DATE OF PURCHASE, AMOUNT PAID AND PLACE OF PURCHASE. CUSTOMER WILL BE CHARGED FOR THE REPAIR OF ANY UNIT RECEIVED WITHOUT SUCH PROOF OF PURCHASE.

Limited Warranty Limits And Exclusions

This Limited Warranty ONLY COVERS failures due to defects in materials or workmanship, and DOES NOT COVER normal wear and tear or cosmetic damage. The Limited Warranty ALSO DOES NOT COVER damages which occurred in shipment, or failures which are caused by products not supplied by the warrantor, or failures which result from accidents, misuse, abuse, neglect, mishandling, misapplication, alteration, faulty installation, set-up adjustments, misadjustment of consumer controls, improper maintenance, power line surge, lightning damage, modification, or commercial use (such as hotel, office, restaurant, or other business), rental use of the product, or service by anyone other than a Factory Servicer or other Authorized Servicer, or damage that is attributable to acts of God.

THERE ARE NO EXPRESS WARRANTIES EXCEPT AS LISTED UNDER "LIMITED WARRANTY COVERAGE". THE WARRANTOR IS NOT LIABLE FOR INCIDENTAL OR CONSEQUENTIAL DAMAGES RESULTING FROM THE USE OF THIS PRODUCT, OR ARISING OUT OF ANY BREACH OF THIS WARRANTY. (As examples, this excludes damages for lost time, cost of having someone remove or re-install an installed unit if applicable, travel to and from the servicer, loss of or damage to media or images, data or other recorded content. The items listed are not exclusive, but are for illustration only.)
ALL EXPRESS AND IMPLIED WARRANTIES, INCLUDING THE WARRANTY OF MERCHANTABILITY, ARE LIMITED TO THE PERIOD OF THE LIMITED WARRANTY.

Some states do not allow the exclusion or limitation of incidental or consequential damages, or limitations on how long an implied Limited Warranty lasts, so the exclusions may not apply to you.

This Limited Warranty gives you specific legal rights and you may also have other rights which vary from state to state. If a problem with this product develops during or after the Limited Warranty period, you may contact your dealer or Servicer. If the problem is not handled to your satisfaction, then write to the warrantor's Consumer Affairs Department at the addresses listed for the warrantor.

PARTS AND SERVICE, WHICH ARE NOT COVERED BY THIS LIMITED WARRANTY, ARE YOUR RESPONSIBILITY.

Customer Services Directory

Obtain Product Information and Operating Assistance; purchase Parts, Accessories, or obtain Literature by visiting our Web Site at:

<http://www.panasonic.com/consumersupport>

or, contact us via the web at:

<http://www.panasonic.com/contactinfo>

You may also contact us directly at:

1-800-211-PANA (7262),

Monday-Friday 9 am-9 pm; Saturday-Sunday 10 am-7 pm, EST.

For hearing or speech impaired TTY users, TTY: 1-877-833-8855

Accessory Purchases

Purchase Parts, Accessories and Instruction Books online for all Panasonic Products by visiting our Web Site at:

<http://www.pstc.panasonic.com>

or, send your request by E-mail to:

npcparts@us.panasonic.com

You may also contact us directly at:

1-800-332-5368 (Phone) 1-800-237-9080 (Fax Only) (Monday - Friday 9 am to 9 pm, EST.)

Panasonic Service and Technology Company

20421 84th Avenue South, Kent, WA 98032

(We Accept Visa, MasterCard, Discover Card, American Express, and Personal Checks)

For hearing or speech impaired TTY users, TTY: 1-866-605-1277

Product Repairs

MAIL TO:

Centralized Factory Servicer

Panasonic Service and Technology Company

410B Airport Road

Elgin, IL 60123-9333

Attention: BD/DVD Repair

Please carefully pack and ship, prepaid and insured, to the Elgin Centralized Factory Servicer. Customers in Puerto Rico, please ship or carry in to location below ("Service in Puerto Rico").

Service in Puerto Rico

Panasonic Puerto Rico, Inc.

Ave. 65 de Infantería, Km. 9.5, San Gabriel Industrial Park, Carolina, Puerto Rico 00985

Phone (787)750-4300, Fax (787)768-2910

Limited Warranty (ONLY FOR CANADA)

Panasonic Canada Inc.

PANASONIC PRODUCT—LIMITED WARRANTY

Panasonic Canada Inc. warrants this product to be free from defects in material and workmanship and agrees to remedy any such defect for a period as stated below from the date of original purchase.

Technics Audio Product	One (1) year, parts and labour
Panasonic Portable/Clock Radio (without Tape, CD, MD)	One (1) year, parts and labour
Panasonic Audio/SD Audio Product	One (1) year, parts and labour
Panasonic BD/DVD Product	One (1) year, parts and labour
Panasonic Combination DVD Player/VCR	One (1) year, parts and labour
Panasonic Combination DVD Recorder/VCR	One (1) year, parts and labour
Accessories including rechargeable batteries	Ninety (90) days

LIMITATIONS AND EXCLUSIONS

This warranty does not apply to products purchased outside Canada or to any product which has been improperly installed, subjected to usage for which the product was not designed, misused or abused, damaged during shipping, or which has been altered or repaired in any way that affects the reliability or detracts from the performance, nor does it cover any product which is used commercially. Dry cell batteries are also excluded from coverage under this warranty.

This warranty is extended to the original end user purchaser only. A purchase receipt or other proof of date of original purchase is required before warranty service is performed.

THIS EXPRESS, LIMITED WARRANTY IS IN LIEU OF ALL OTHER WARRANTIES, EXPRESS OR IMPLIED, INCLUDING ANY IMPLIED WARRANTIES OF MERCHANTABILITY AND FITNESS FOR A PARTICULAR PURPOSE.

IN NO EVENT WILL PANASONIC CANADA INC. BE LIABLE FOR ANY SPECIAL, INDIRECT OR CONSEQUENTIAL DAMAGES.

In certain instances, some jurisdictions do not allow the exclusion or limitation of incidental or consequential damages, or the exclusion of implied warranties, so the above limitations and exclusions may not be applicable.

WARRANTY SERVICE

FOR PRODUCT OPERATION ASSISTANCE, please contact:

Our Customer Care Centre:	Telephone #:	(905) 624-5505
	1-800 #:	1-800-561-5505
	Fax #:	(905) 238-2360
	Email link:	"Customer support" on www.panasonic.ca

FOR PRODUCT REPAIRS, please locate your nearest Authorized Servicentre at www.panasonic.ca :

Link : "Servicentres™ locator" under "Customer support"

IF YOU SHIP THE PRODUCT TO A SERVICENTRE

Carefully pack and send prepaid, adequately insured and preferably in the original carton.
Include details of the defect claimed, and proof of date of original purchase.

Product Service

- 1. Damage requiring service**—The unit should be serviced by qualified service personnel if:
 - (a) The AC power supply cord or AC adaptor has been damaged; or
 - (b) Objects or liquids have gotten into the unit; or
 - (c) The unit has been exposed to rain; or
 - (d) The unit does not operate normally or exhibits a marked change in performance; or
 - (e) The unit has been dropped or the cabinet damaged.
- 2. Servicing**—Do not attempt to service the unit beyond that described in these operating instructions. Refer all other servicing to authorized servicing personnel.

- 3. Replacement parts**—When parts need replacing ensure the servicer uses parts specified by the manufacturer or parts that have the same characteristics as the original parts. Unauthorized substitutes may result in fire, electric shock, or other hazards.
- 4. Safety check**—After repairs or service, ask the servicer to perform safety checks to confirm that the unit is in proper working condition.

The servicer will require all components to service your system. Therefore, should service ever be necessary, be sure to bring the entire system.

Product information

For product information or assistance with product operation:

In the U.S.A., refer to "Customer Services Directory" on page 46. In Canada, contact the Panasonic Canada Inc. Customer Care Centre at 1-800-561-5505, or visit the website (www.panasonic.ca), or an authorized Servicentre closest to you.

Index

A Angle	30	E Equalizer (EQ)	26	P Picture-in-picture	24, 43
Audio		F Finalize	12	Picture quality adjustment	31
Attribute	30	Final Standard Profile	24, 43	Playlist	21, 25
Changing audio	16	FM/AM outdoor antenna	36	Pop-up Menu	24
Channel	30	Format	24	Power consumption	8
Language	30, 32	FUNCTIONS menu	25	Progressive	31, 43
AVCHD	43	H H.Bass	26	Properties	
B BD-J	43	Headphone	14	Chapter	16
BD-Video Ratings	32	HDMI	7, 43	Still picture	23
C Chapter	16	I iPod	20	R Radio	
Cleaning		Connection	20	Listening to the radio	18
Disc	42	Playback	21	Presetting stations	9, 18
Lens	42	J JPEG	13, 22, 43	Random	31
Main unit	42	L Language		Ratings level	32
Connection		Audio	30, 32	Remote control code	42
Amplifier	36	Code list	37	Repeat play	21, 31
Antenna	8, 36	On-screen	33	Restore Default Settings	32
AUX	7, 35	Soundtrack	30	Resume play function	15
Cable box, satellite receiver	35	Subtitle	30, 32	S SD card	12, 24
COMPONENT VIDEO OUT	35	Local storage	43	Setup menu	32
Digital transmitter	6	LPCM	43	Shuffle	21
HDMI	7	M Maintenance	42	Sleep timer	16
iPod	20	Menu		Slideshow	23
OPTICAL IN	7, 35	On-screen	30	Soundtrack	30
Speaker	6	Pop-up	24	Speakers	5, 6, 33, 34
TV	7, 35	Setup	32	Status Messages	16
Video cassette recorder	35	Sub	16, 23	Still pictures	22
Wireless system	6	MP3	13, 19, 43	Subtitle	30
D Direct Navigator	14	Muting	16	Subwoofer boost	26
Dolby Digital	30, 43	N Noise reduction (NR)		Subwoofer level	26
Dolby Digital Plus	30, 43	Integrated NR	31	Surround Enhancer	26
Dolby Pro Logic II	27, 43	3D NR	31	T Transfer	31
Dolby Pro Logic IIx	27, 43	O Off Timer	32	U Unit care	42
Dolby TrueHD	30, 43	On-screen		V VIERA Link "HDAVI Control™"	28
DTS	30, 43	Language	33	Virtual package	24, 43
DTS-HD	30, 43	Menu	30	W Whisper-mode Surround	26
DTS NEO:6	27, 43	Status messages	16	Z Zoom	23
DVD-Video Ratings	32	OPTICAL IN	7, 35	24p	33, 43

-If you see this symbol-

Information on Disposal in other Countries outside the European Union



This symbol is only valid in the European Union. If you wish to discard this product, please contact your local authorities or dealer and ask for the correct method of disposal.

CAUTION!
DO NOT INSTALL OR PLACE THIS UNIT IN A BOOKCASE, BUILT-IN CABINET OR IN ANOTHER CONFINED SPACE. ENSURE THE UNIT IS WELL VENTILATED. TO PREVENT RISK OF ELECTRIC SHOCK OR FIRE HAZARD DUE TO OVERHEATING, ENSURE THAT CURTAINS AND ANY OTHER MATERIALS DO NOT OBSTRUCT THE VENTILATION VENTS.

CAUTION

Danger of explosion if battery is incorrectly replaced. Replace only with the same or equivalent type recommended by the manufacturer. Dispose of used batteries according to the manufacturer's instructions.

The socket outlet shall be installed near the equipment and easily accessible. The mains plug of the power supply cord shall remain readily operable. To completely disconnect this apparatus from the AC Mains, disconnect the power supply cord plug from AC receptacle.

For wireless system

Product Identification Marking is located on the bottom of unit.



(Inside of product)

For U.S.A.

Panasonic Consumer Electronics Company, Division of Panasonic Corporation of North America
One Panasonic Way Secaucus, New Jersey 07094
<http://www.panasonic.com>

Panasonic Puerto Rico, Inc.
Ave. 65 de Infantería, Km. 9.5
San Gabriel Industrial Park, Carolina, Puerto Rico 00985

For Canada

Panasonic Canada Inc.
5770 Ambler Drive
Mississauga, Ontario
L4W 2T3
www.panasonic.ca

