

SONY[®]

3-294-082-13(1)

LCD Digital Color TV



Operating Instructions

KDL-26M4000
KDL-32M4000
KDL-37M4000
KDL-40M4000

BRAVIA

Owner's Record

The model and serial numbers are located at the rear of the TV. Record these numbers in the spaces provided below. Refer to them whenever you call upon your Sony dealer regarding this TV.

Model Name

Serial No.

CAUTION

To prevent electric shock, do not use this polarized AC plug with an extension cord, receptacle or other outlet unless the blades can be fully inserted to prevent blade exposure.

Declaration of Conformity

Trade Name: SONY
Model: KDL-26M4000/KDL-32M4000/
KDL-37M4000/KDL-40M4000
Responsible Party: Sony Electronics Inc.
Address: 16530 Via Esprillo
San Diego, CA 92127 U.S.A.
Telephone Number: 858-942-2230

This device complies with part 15 of the FCC rules. Operation is subject to the following two conditions: (1) This device may not cause harmful interference, and (2) this device must accept any interference received, including interference that may cause undesired operation.

NOTIFICATION

This equipment has been tested and found to comply with the limits for a Class B digital device, pursuant to Part 15 of the FCC Rules. These limits are designed to provide reasonable protection against harmful interference in a residential installation. This equipment generates, uses and can radiate radio frequency energy and, if not installed and used in accordance with the instructions, may cause harmful interference to radio communications. However, there is no guarantee that interference will not occur in a particular installation. If this equipment does cause harmful interference to radio or television reception, which can be determined by turning the equipment off and on, the user is encouraged to try to correct the interference by one or more of the following measures:

- Reorient or relocate the receiving antenna.
- Increase the separation between the equipment and receiver.
- Connect the equipment into an outlet on a circuit different from that to which the receiver is connected.
- Consult the dealer or an experienced radio/TV technician for help.

Pursuant to FCC regulations, you are cautioned that any changes or modifications not expressly approved in this manual could void your authority to operate this equipment.

Safety

- Operate the TV only on 120 V AC.
- Use the AC power cord specified by Sony and suitable for the voltage where you use it.
- The plug is designed, for safety purposes, to fit into the wall outlet only one way. If you are unable to insert the plug fully into the outlet, contact your dealer.
- If any liquid or solid object should fall inside the cabinet, unplug the TV immediately and have it checked by qualified service personnel before operating it further.
- If you will not be using the TV for several days, disconnect the power by pulling the plug itself. Never pull on the cord.
- When disconnecting AC power cord, the power cord should be easily accessible for disconnection.
- For details concerning safety precautions, see "Safety and Regulatory Booklet".

Installing

- The TV should be installed near an easily accessible power outlet.
- To prevent internal heat buildup, do not block the ventilation openings.
- Do not install the TV in a hot or humid place, or in a place subject to excessive dust or mechanical vibration.
- Avoid operating the TV at temperatures below 41°F (5°C).
- If the TV is transported directly from a cold to a warm location, or if the room temperature changes suddenly, the picture may be blurred or show poor color due to moisture condensation. In this case, please wait a few hours to let the moisture evaporate before turning on the TV.
- To obtain the best picture, do not expose the screen to direct illumination or direct sunlight. It is recommended to use spot lighting directed down from the ceiling or to cover the windows that face the screen with opaque drapery. It is desirable to install the TV in a room where the floor and walls are not of a reflective material.

CAUTION

Use the following Sony TVs only with the following WALL-MOUNT BRACKET or TV-stand.

Sony TV Model No.			
	KDL-26M4000	KDL-32M4000 KDL-37M4000	KDL-40M4000
Sony Wall-Mount Bracket Model No.	SU-WL100	SU-WL500	
Sony TV Stand Model No.	-	-	RHT-S10

Use with other WALL-MOUNT BRACKET or TV-stand may cause instability and possibly result in injury.

To Customers

Sufficient expertise is required for installing the specified TV. Be sure to subcontract the installation to Sony dealer or licensed contractors and pay adequate attention to safety during the installation.

Note

This television includes a QAM demodulator which should allow you to receive unscrambled digital cable television programming via subscription service to a cable service provider. Availability of digital cable television programming in your area depends on the type of programming and signal provided by your cable service provider.

For Customers in Canada

This Class B digital apparatus complies with Canadian ICES-003.

For Customers in the United States

Lamp in this product contains mercury. Disposal of these materials may be regulated due to environmental considerations. For disposal or recycling information, please contact your local authorities or the Electronic Industries Alliance (www.eiae.org).

Trademark Information

Macintosh is a trademark licensed to Apple, Inc., registered in the U.S.A. and other countries.

Manufactured under license from Dolby Laboratories. "Dolby" and double-D symbol are trademarks of Dolby Laboratories.

This TV incorporates High-Definition Multimedia Interface (HDMI™) technology. HDMI, the HDMI logo and High-Definition Multimedia Interface are trademarks or registered trademarks of HDMI Licensing, LLC.

Ferguson Patent Properties, LLC:
U.S. Patent No. 5, 717, 422
U.S. Patent No. 6, 816, 141

Blu-ray is a trademark.

"BRAVIA" and BRAVIA, BRAVIA Theatre Sync and  are trademarks or registered marks of Sony Corporation.

"PLAYSTATION" is a registered trademark and "PS3" is a trademark of Sony Computer Entertainment Inc.



Contents

Welcome to the World of BRAVIA®

The Four Steps to Stunning HD Experience: Set, Sound, Source, and Setup	4
Picture Quality and Aspect Ratio	4

Getting Started

1. Installing the TV	5
How to Carry the TV	5
How to Attach the Table-Top Stand	5
Securing the TV	6
Bundling the Connecting Cables	8
Preparation for Wall-Mounting	8
Installing the Wall-Mount Bracket	9
When Installing the TV Against a Wall or Enclosed Area	11
2. Locating Inputs and Outputs	12
Side Panel	12
Rear Panel	12
3. Connecting the TV	14
Cable System and/or VHF/UHF	14
HD Cable Box/HD Satellite Box	14
PC	16
Other Equipment	17
4. Setting Up the Channel List - Initial Setup	18







Exploring Fun Features

Using BRAVIA Theatre Sync™ with Control for HDMI.....	19
--	----

Remote Control and TV Controls/Indicators

Inserting Batteries	20
When Using the Remote Control	20
Remote Control	21
TV Controls/Indicators	25

Using TV Menus

Navigating through TV Menus	27
Menu Descriptions	27
 Using the Shortcuts Menu	28
 Using the Picture Menu	30
 Using the Sound Menu	31
 Using the Screen Menu	32
 Using the Channel Menu	33
 Using the Parental Lock	34
 Using the Setup Menu	37

Other Information

Troubleshooting.....	39
Specifications.....	42
Index.....	43

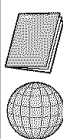

Quick Setup Guide (separate volume)

Provides a variety of optional equipment connection diagrams.

Customer Support

<http://www.sony.com/tvsupport>

On-line Registration

United States

<http://productregistration.sony.com>

Canada

<http://www.sonystyle.ca/registration>

Welcome to the World of BRAVIA®

Thank you for purchasing this Sony BRAVIA® high-definition television. The quality of the image you see on your BRAVIA TV is only as good as the quality of the signal it receives. To experience the stunning detail of your new BRAVIA TV, you need access to HD programming. Your BRAVIA TV can receive and display HD programming from:

- Over-the-air broadcasting via HD-quality antenna
- HD cable subscription
- HD satellite subscription
- Blu-ray Disc™ player or other external equipment

Contact your cable or satellite provider for information on upgrading to HD programming.

To learn more about HDTV, visit:

U.S.A <http://www.sony.com/HDTV>

Canada <http://www.sonystyle.ca/hd>

The Four Steps to Stunning HD Experience: Set, Sound, Source, and Setup

Along with your BRAVIA TV set, a complete HD system requires an HD sound system, a source of HD programming and proper setup connections. This manual explains basic setup connections (see page 14). The Quick Setup Guide, enclosed separately, illustrates how to connect other optional equipment.

Picture Quality and Aspect Ratio

You can enjoy crisp, clear images, smooth movement and high-impact visuals from 1080i HD signals. When you compare a high-definition signal to a standard analog signal, you will notice a big difference. The 1080i HD signals provide more than twice the vertical resolution of the standard TV signal.

High-definition and standard-definition signals are transmitted with different aspect ratios (the width-to-height ratio of the image). HDTV uses a wider screen than conventional standard-definition TV.

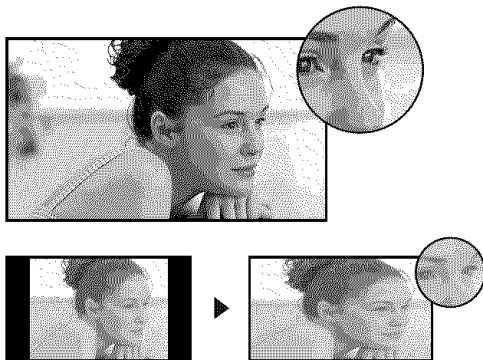

16:9 (high-definition) source

Most HDTV signals use a wide screen aspect ratio of 16:9. The 16:9 fills your BRAVIA screen, maintaining a crisp, clear, vivid picture.

4:3 (standard-definition) source

Most standard-definition signals use a boxy 4:3 aspect ratio. When a 4:3 image is displayed on an HDTV, you will see black bars on the sides. The picture quality may not be as sharp as with HD sources.



- You can use the **Wide Mode** function of the TV to adjust the 4:3 image to fit the entire screen (see pages 23 and 32).
- This TV supports signals up to 1080i.

Getting Started

1. Installing the TV

How to Carry the TV

Be sure to follow these guidelines to protect your properties and avoid causing serious injury.

- Before carrying the TV, disconnect all cables.
- Carrying the large size TV requires two or more people.
- When you carry the TV, place your hand as illustrated and hold it securely. Do not put stress on the LCD panel.
- When carrying the TV, do not subject it to shocks or vibration, or excessive force.

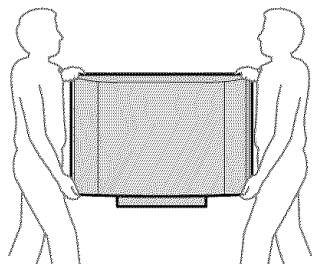

- Place your palm directly underneath but do not squeeze the panel's speaker grill area.

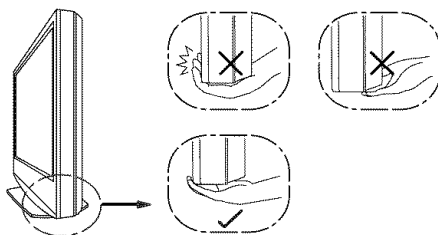

How to Attach the Table-Top Stand

The Table-Top Stand for this product is packaged separately. Install the TV unit to the Table-Top Stand before the connection and setup.

- 1 Take out the Table-Top Stand from the cushion and the 3 screws from the accessory bag.



- You will find the Table-Top Stand next to the TV unit.
- Keep the screws away from children.

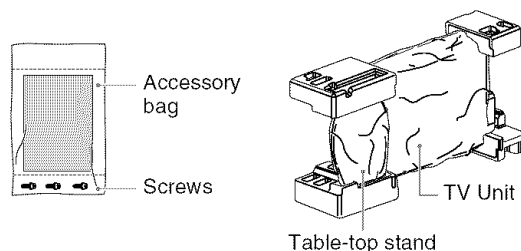

- 2 Place the Table-Top Stand onto a level and stable surface.

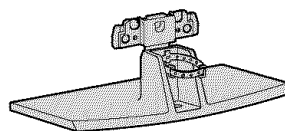

(Continued)

- 3 Gently slide the TV unit onto the neck of the Table-Top Stand and align the screws holes.

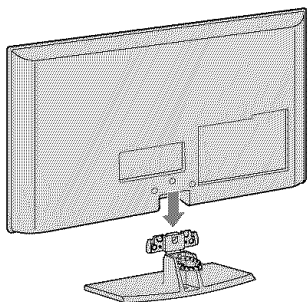

- When you carry the TV unit, place your hand as illustrated (page 5) and hold it securely. Do not put stress on the LCD panel and the frame around the screen.
- Be careful to not pinch your hands or the AC power cord when you install the TV unit to the Table-Top Stand.

- 4 Stabilize the TV unit and the Table-Top Stand with supplied 3 screws.

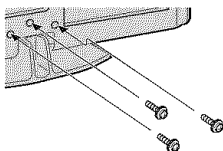

- If you use an electric screwdriver, set the torque for tightening at approximately 1.5 N·m {15Kg·cm}.

Securing the TV



Sony strongly recommends taking measures to prevent the TV from toppling over; as unsecured TVs may topple and result in property damage, serious bodily injury or even death.

Prevent the TV from Toppling

- Secure the TV to a wall and/or stand.
- Do not allow children to play or climb on furniture and TV sets.
- Avoid placing or hanging items on the TV.
- Never install the TV on:
 - slippery, unstable and/or uneven surfaces.
 - furniture that can easily be used as steps, such as a chest of drawers.
- Install the TV where it cannot be pulled, pushed, or knocked over.
- Route all AC power cords and connecting cables so that they are not accessible to children.

Use a Sony TV Stand

Use a Sony specified TV stand (see page 2) and follow the instruction manual provided with the Sony TV stand.

If a Sony specified TV stand is not used, consider the following recommended measures.

Recommended Measures to Secure the TV

- 1 Secure the stand for the TV.

Make sure the TV stand can adequately support the weight of the TV. Use two angle braces (not supplied) to secure the stand.

For each angle brace use the appropriate hardware to:

- attach one side of the angle brace to the wall stud.
- attach the other side to the TV stand.

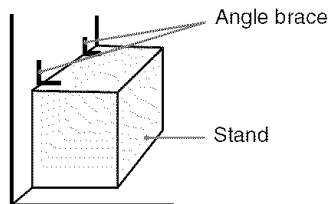

2 Secure the TV to the stand.

Use the optional hardware listed below (not supplied):

- M6 × 12-18 mm anchor bolt (screwed into the TV's Table-Top stand)
- A screw or similar (attach it to the TV stand)
- Rope or chain (strong enough to support the weight of the TV). Make sure that there is no excess slack in the rope or chain.

An alternative way to secure the TV is with an optional Sony Support Belt Kit.

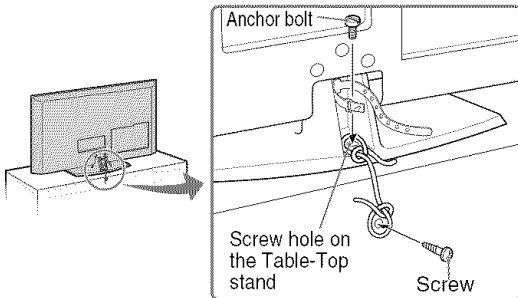

Contact Sony Customer Support to obtain the optional Support Belt Kit by providing your TV model name.

- For United States call: 1-800-488-7669 or visit: www.sony.com/accessories
- For Canada call: 1-877-899-7669

3 Anchor the TV to the Wall.

Use the hardware listed below (not supplied):

- Two M6 × 12-18 mm anchor bolts (screw into the top-most wall-mount holes located on the rear of the TV)
- Rope or chain (attach to one M6 anchor bolt)
- Wall-anchor (attach to the wall stud) strong enough to support the weight of the TV (pass the rope through the wall-anchor, then attach to the other M6 anchor bolt).

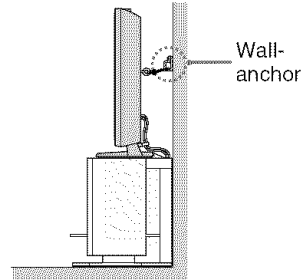
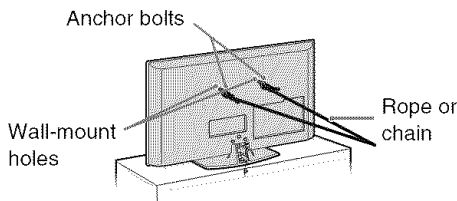

- Measure 2 provides minimal protection against the TV toppling over. For further protection, follow all three measures recommended above.

(Continued)

Bundling the Connecting Cables

You can bundle the connecting cables as illustrated below.

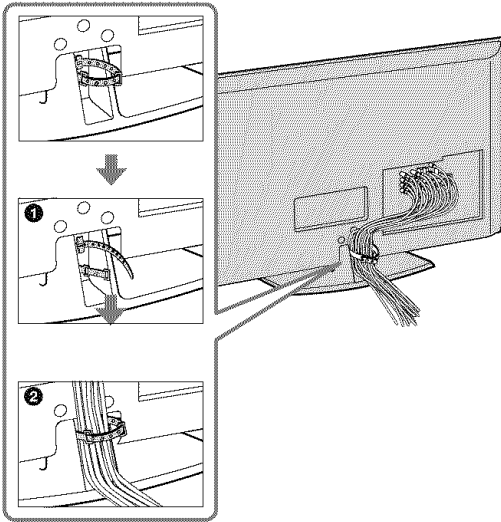

- Do not bundle the AC power cord with other connecting cables.

Preparation for Wall-Mounting

This TV can be installed on a wall by using a Wall-Mount Bracket (sold separately). Before mounting the TV on a wall, the Table-Top Stand must be removed from the TV.



- Do not remove the Table-Top Stand for any reason other than to wall-mount the TV.
- For product protection and safety reasons, Sony strongly recommends that you use the Wall-Mount Bracket model designed for your TV and the wall-mounting of your TV should be performed by a Sony dealer or licensed contractor.

Use your TV with the following WALL-MOUNT BRACKET only.

Sony TV Model No.		
	KDL-26M4000	KDL-32M4000 KDL-37M4000 KDL-40M4000
Sony Wall-Mount Bracket Model No.	SU-WL100	SU-WL500

- For bracket installation, refer to the instructions on page 9 and the instruction guide provided by the Wall-Mount Bracket model for your TV. Sufficient expertise is required in installing this TV, especially to determine the strength of the wall for withstanding the TV's weight.
- Be sure to store the removed screws and Table-Top Stand in a safe place until you are ready to reattach the Table-Top Stand. **Keep the screws away from children.**

Follow the simple steps below to remove the Table-Top Stand:

- 1 Disconnect all the cables from the TV.
- 2 Remove the 3 screws from behind the TV as indicated below. **Do not remove any other screws from the TV.**

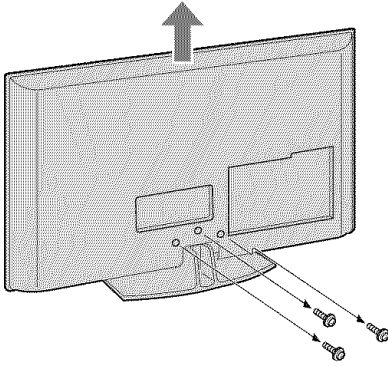

- 3 Gently lay the TV (face down) onto a level and stable surface covered with a thick and soft cloth.
- 4 Secure the Mounting Hooks to the rear of the TV. For more details refer to **Install the Wall-Mount Bracket** and also the **Instruction Guide** provided by the Wall-Mount Bracket model for your TV.



- If an electric screwdriver is used, set the torque to tighten at approximately 1.5 N·m {15Kg·cm}.

Installing the Wall-Mount Bracket

To Customers

Your KDL-26M4000/KDL-32M4000/KDL-37M4000/KDL-40M4000 can be wall-mounted using a Wall-Mount Bracket (sold separately). See table on page 8 showing the Wall-Mount Bracket model appropriate for your TV.

For product protection and safety, Sony strongly recommends that you use the Wall-Mount Bracket designed for your TV and wall-mounting is performed by a Sony dealer or a licensed contractor. Do not attempt to install it yourself. Sony is not liable for any damage or injury caused by mishandling or improper installation.

Please provide this installation information as well as the instruction supplied in the Wall-Mount Bracket package to your installer.

To Sony Dealers and Licensed Contractors

To avoid injury and property damage, read these instructions carefully. Periodic inspection and maintenance is highly recommended to ensure that TV is securely mounted.

Installing the Wall-Mount Bracket and Mounting Hooks

- 1 Open the Wall-Mount Bracket package and check for all the required parts including the instruction.
- 2 See Installation dimensions table to determine the best location for wall-mounting. The wall must be strong enough to support at least four times the weight of the TV. Also refer to the instruction provided with your Wall-Mount Bracket.

(Continued)

Installation dimensions table

Unit: inches (mm)	TV Model	KDL-26M4000	KDL-32M4000	KDL-37M4000	KDL-40M4000	
TV dimensions	A	26 5/8 (675)	31 7/8 (809)	36 3/4 (931)	39 3/8 (997)	
	B	18 3/8 (466)	21 3/8 (542)	24 (609)	25 3/8 (644)	
Screen center dimensions	C	3 (75)	4 (101)	6 5/8 (168)	6 (151)	
	D	13 1/4 (335)	18 3/8 (465)	18 3/8 (464)	18 3/8 (465)	
Length for each mounting angle	Angle (0°)	E	6 1/4 (157)	6 3/8 (159)	6 3/8 (170)	6 3/8 (170)
		F	10 5/8 (269)	12 1/4 (309)	13 1/2 (342)	14 1/8 (357)
	Angle (20°)	G	17 7/8 (453)	20 3/4 (527)	23 1/8 (587)	24 1/2 (620)
		H	13 1/2 (342)	19 7/8 (503)	20 (506)	19 5/8 (497)
Weight	TV	22 lb. (10 kg)	31 lb. (14 kg)	38 lb. (17 kg)	47 lb. (21 kg)	
	x4	88 lb. (40 kg)	124 lb. (56 kg)	152 lb. (68 kg)	188 lb. (84 kg)	



- Installation dimensions may differ according to how the TV is installed.
- The wall must be strong enough to support at least four times the weight of the TV that you are installing.

For Model KDL-26M4000

Unit: inches (mm)

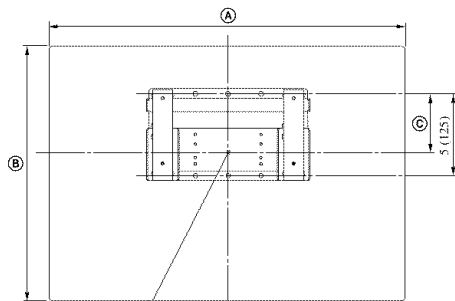

Center line of the screen when installed on the wall

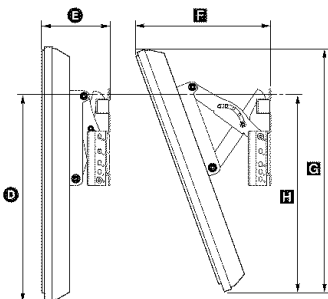

For Models KDL-32M4000/KDL-37M4000/ KDL-40M4000

Unit: inches (mm)

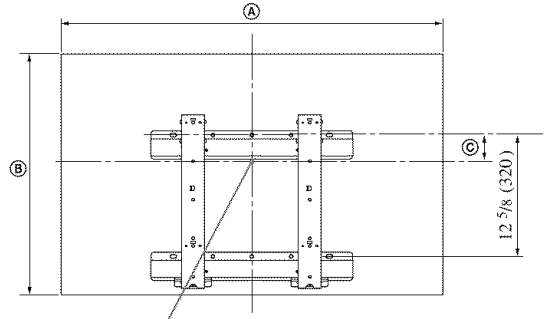

Center line of the screen when installed on the wall

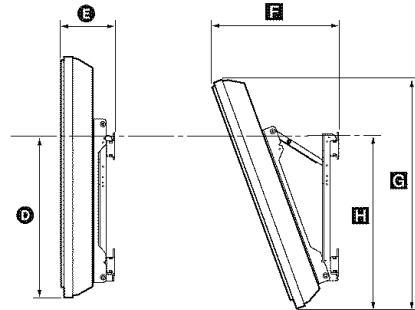

- 3 Install the Base Bracket on the wall. Refer to the instruction provided with your Wall-Mount Bracket.
- 4 Disconnect all cables and remove the Table-Top Stand. See page 8 for details.
- 5 Install Mounting Hooks on the TV. See Screw and Hook locations table below.

Screw and Hook locations diagram/table

TV Model	Screw location	Hook location
KDL-26M4000	-	a
KDL-32M4000	f, j	c
KDL-37M4000	f, j	b
KDL-40M4000	e, g	b

Screw location

When installing the Mounting Hooks on the TV.

For Models KDL-32M4000/
KDL-37M4000/KDL-40M4000

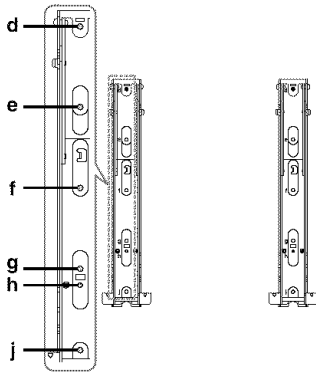

Hook location

When installing the TV onto Base Bracket.

For Model KDL-26M4000

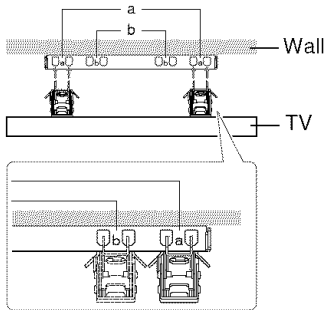

For Model KDL-32M4000/KDL-37M4000/
KDL-40M4000

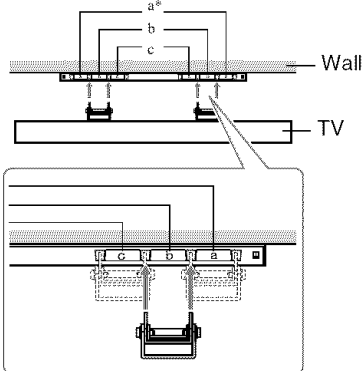

* Hook position "a" cannot be used for the models in the table above.

When Installing the TV Against a Wall or Enclosed Area

Make sure that your TV has adequate air circulation. Allow enough space around the TV as shown below.

Installed on the wall

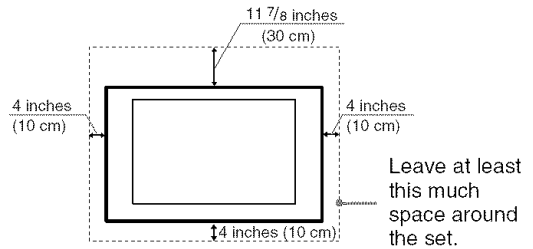

Installed with stand

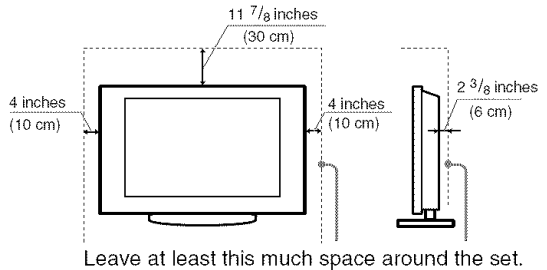

Never install the TV set as follows:

Air circulation is blocked. Air circulation is blocked.

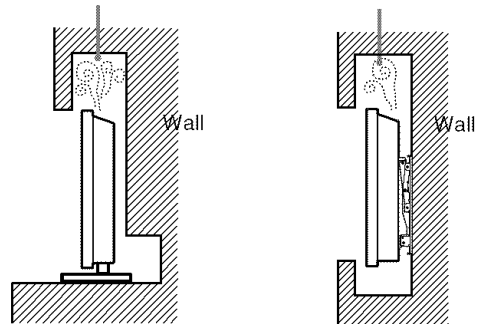



- Inadequate air circulation can lead to overheating of the TV and may cause damage to your TV or cause fire.

2. Locating Inputs and Outputs

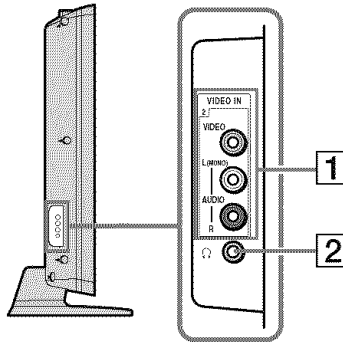



Side Panel

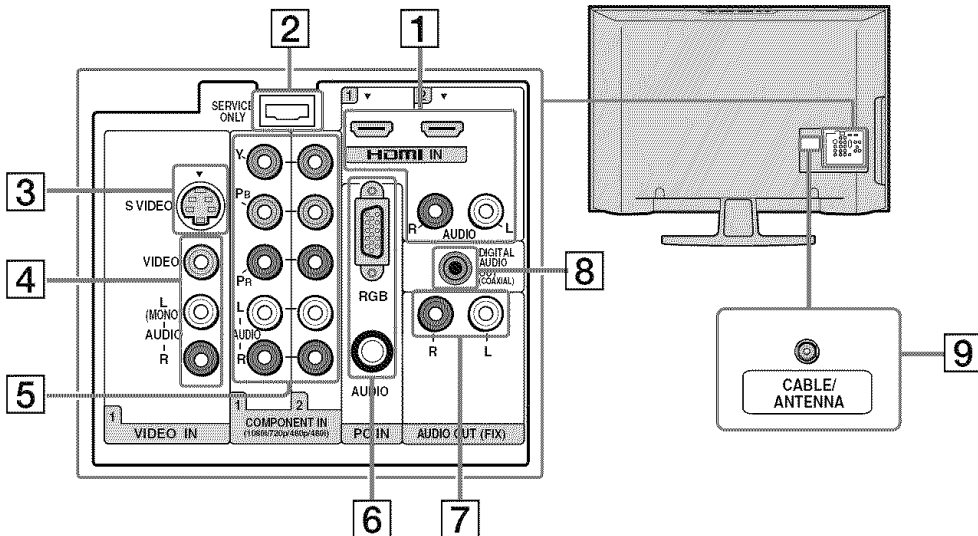

Item	Description
1 VIDEO IN 2 VIDEO/ L (MONO) - AUDIO - R	<p>Connects to the composite video and audio output jacks on your camcorder or other video equipment such as a DVD or video game equipment.</p> <p> • If you have mono equipment, connect its audio output jack to the TV's L (MONO) audio input jack.</p>
2 Headphone jack	<p>Connects to your headphones. If your headphones do not match the jack, use a suitable plug adapter (not supplied).</p> <p> • While headphones are connected, the TV speakers are muted.</p>

Rear Panel

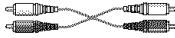

Item	Description
1 HDMI IN 1/2 R-AUDIO-L	<p>HDMI (High-Definition Multimedia Interface) provides an uncompressed, all-digital audio/video interface between this TV and any HDMI-equipped audio/video equipment, such as DVD player, a set-top box, A/V receiver and Blu-ray Disc player as well as PC. HDMI supports enhanced or high-definition video plus digital audio.</p>  <ul style="list-style-type: none"> • If the equipment has a DVI and not a HDMI connector, use a DVI-to-HDMI cable or adapter to connect the DVI output to either HDMI IN 1 or HDMI IN 2 input, and connect the audio jacks to the AUDIO (L/R) jacks below the HDMI IN 2. (DVI connector is for video signals only, the Audio jacks provide support for the audio.) <div style="display: flex; justify-content: space-around; align-items: center;"> <div style="text-align: center;">  <p>DVI-to-HDMI cable</p> </div> <div style="text-align: center;">  <p>DVI-to-HDMI adapter</p> </div> <div style="text-align: center;">  <p>Audio cable</p> </div> </div>  <ul style="list-style-type: none"> • For better PC view, use the PC IN (RGB IN) input. • HDMI connection is necessary to view 480i, 480p, 720p, and 1080i formats. Note that this TV displays all video input signals in a resolution of 1,366 dots × 768 lines.
2 SERVICE ONLY	This USB port is for service only.
3 VIDEO IN 1 S VIDEO	Connects to the S VIDEO output jack of your DVD or other video equipment that has S VIDEO. S VIDEO provides better picture quality than composite video (4). S VIDEO does not provide sound, you need to connect the audio cables.
4 VIDEO IN 1/ VIDEO/ L(MONO)-AUDIO-R	Connects to the composite video and audio output jacks on your A/V equipment such as a DVD player or other video equipment. A second composite video and audio (VIDEO IN 2) input is located on the left side panel of the TV.
5 COMPONENT IN 1/2 (1080i/720p/480p/480i)/ L-AUDIO-R	Connects to your DVD player's or digital set-top box's component video (YPbPr) and audio (L/R) jacks. Component video provides better picture quality than the S VIDEO (3) or the composite video (4) connections.
6 PC IN (RGB/AUDIO)	<p>Connects to a personal computer's video output connector using HD15-HD15 cable (analog RGB, not supplied). See "PC Input Signal Reference Chart" on page 16 for the signals that can be displayed.</p>  <ul style="list-style-type: none"> • For some Apple Macintosh computers, it may be necessary to use an adapter (not supplied). If this is the case, connect the adapter to the computer before connecting the HD15-HD15 cable.
7 AUDIO OUT (FIX) R/L	Connects to the left and right audio input jacks of your audio or video equipment. You can use these outputs to listen to your TV's audio through your stereo system.
8 DIGITAL AUDIO OUT (COAXIAL)	Connects to the coaxial audio input of a digital audio equipment that is PCM/Dolby Digital compatible.
9 CABLE/ ANTENNA	RF input that connects to your cable or VHF/UHF antenna.



- Component video (YPbPr) or HDMI connection are necessary to view 480i, 480p, 720p, and 1080i formats. Note that this TV displays all format types of picture in its native resolution of 1,366 dots × 768 lines.

3. Connecting the TV

Cable System and/or VHF/UHF

Cable or VHF/UHF (or VHF only)

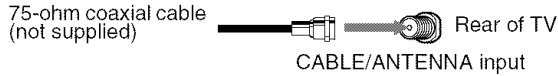

- It is strongly recommended that you connect the antenna/cable input using a 75-ohm coaxial cable (not supplied) to receive optimum picture quality. A 300-ohm twin lead cable can be easily affected by radio frequency interference, resulting in signal degradation.

Cable and VHF/UHF (or VHF only)

If you want to watch both cable and antenna (over-the-air) programming, you will need to use an optional A-B RF Switch (not supplied) to switch between the cable and over-the-air antenna programming, as shown.

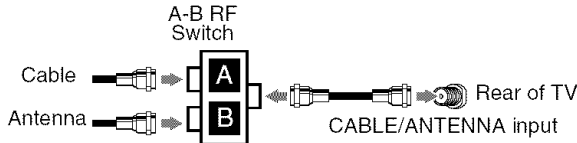

- Be sure to set **Cable** setting to **On** or **Off** in **Channel** menu for the type of input signal you choose (see page 33 for more details).

HD Cable Box/HD Satellite Box

You can also enjoy high-definition programming by subscribing to high-definition cable service or high-definition satellite service. For the best possible picture, connect these components to your TV via the HDMI or component video (with audio) input on the back of your TV.

Shown with HDMI Connection

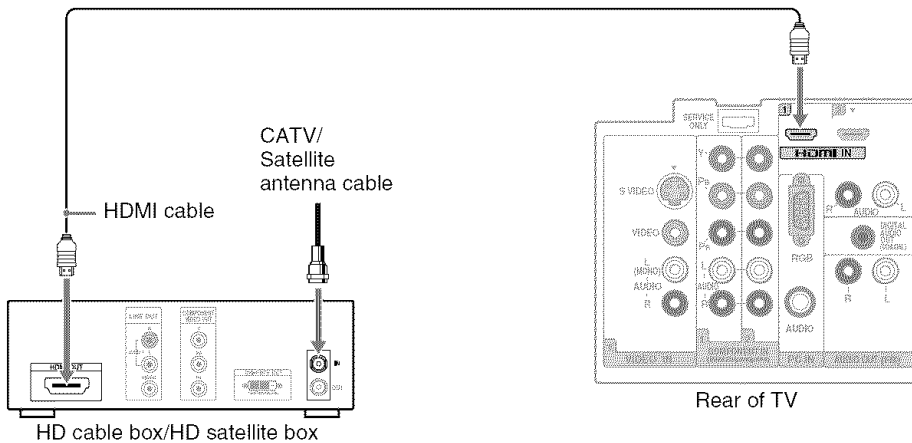

Shown with DVI Connection

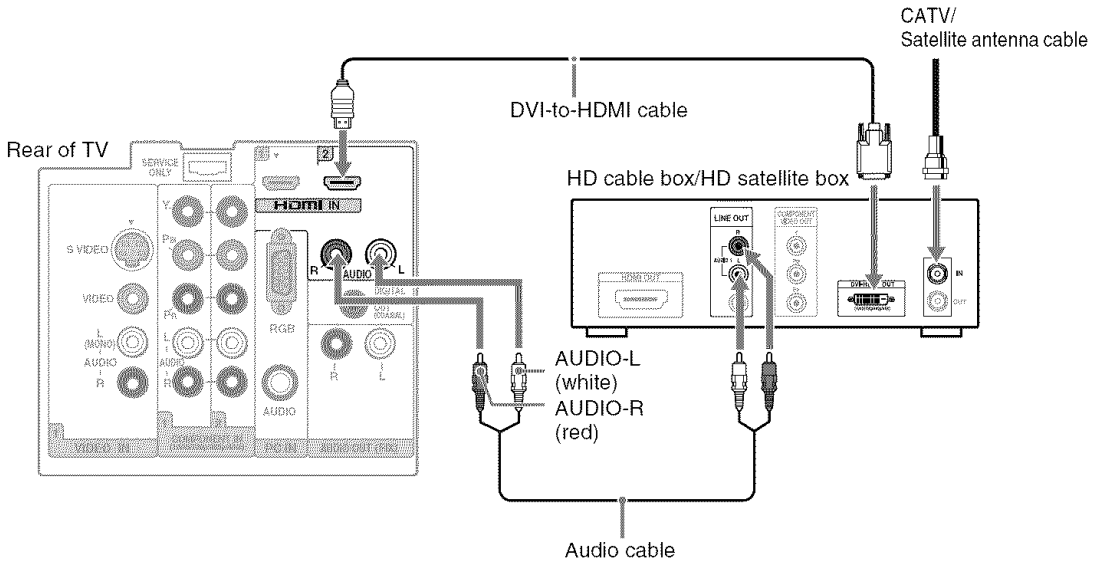

- If the equipment has a DVI and not a HDMI connector, use a DVI-to-HDMI cable or adapter to connect the DVI output to either HDMI IN 1 or HDMI IN 2 input, and connect the audio jacks to the AUDIO (L/R) jacks below the HDMI IN 2 (DVI connector is for video signals only, the Audio jacks provide support for the audio).

Shown with Component Connection

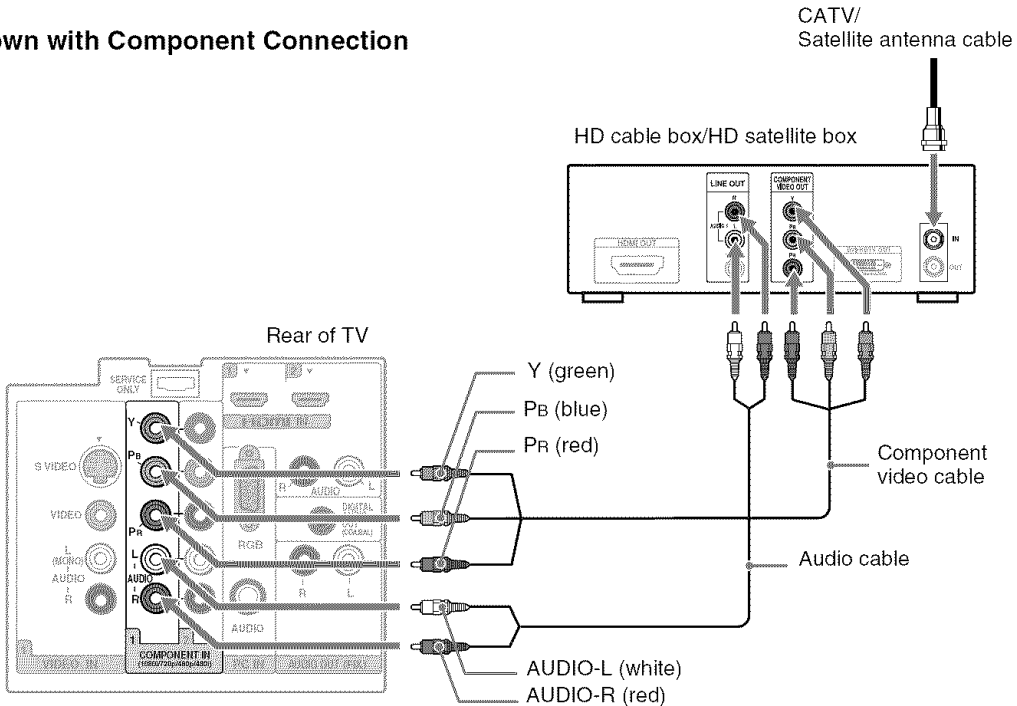

(Continued)

PC

Use the TV as a monitor for your PC.

Shown below with the HD15 to HD15 connection. This TV can also be connected to a PC with DVI or HDMI output. (Refer to the supplied Quick Setup Guide.)

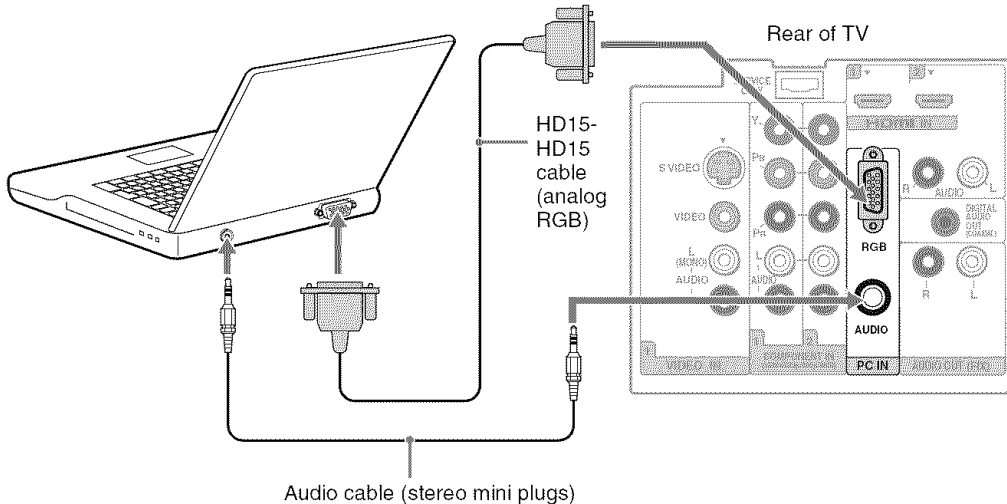

- Connect the PC IN jack to the PC using the HD15-HD15 cable with ferrite core (analog RGB) and audio cable (page 13).

PC Input Signal Reference Chart

After connecting the PC to the TV, set the output signal from the PC according to the chart below.

Signals	Resolution		Horizontal frequency (kHz)	Vertical frequency (Hz)	Standard
	Horizontal (Pixel)	× Vertical (Line)			
VGA	640	× 480	31.5	60	VGA
	640	× 480	37.5	75	VESA
SVGA	800	× 600	37.9	60	VESA Guidelines
	800	× 600	46.9	75	VESA
XGA	1,024	× 768	48.4	60	VESA Guidelines
	1,024	× 768	56.5	70	VESA
	1,024	× 768	60.0	75	VESA
WXGA	1,280	× 768	47.8	60	VESA
	1,360	× 768	47.7	60	VESA



- This TV's PC input does not support Sync on Green or Composite Sync.
- This TV's PC VGA input does not support interlaced signals.
- For the best picture quality, it is recommended to use the signals (boldfaced) in the above chart with a 60 Hz vertical frequency from a personal computer. In plug and play, signals with a 60 Hz vertical frequency will be detected automatically. (PC reboot may be necessary.)

Other Equipment

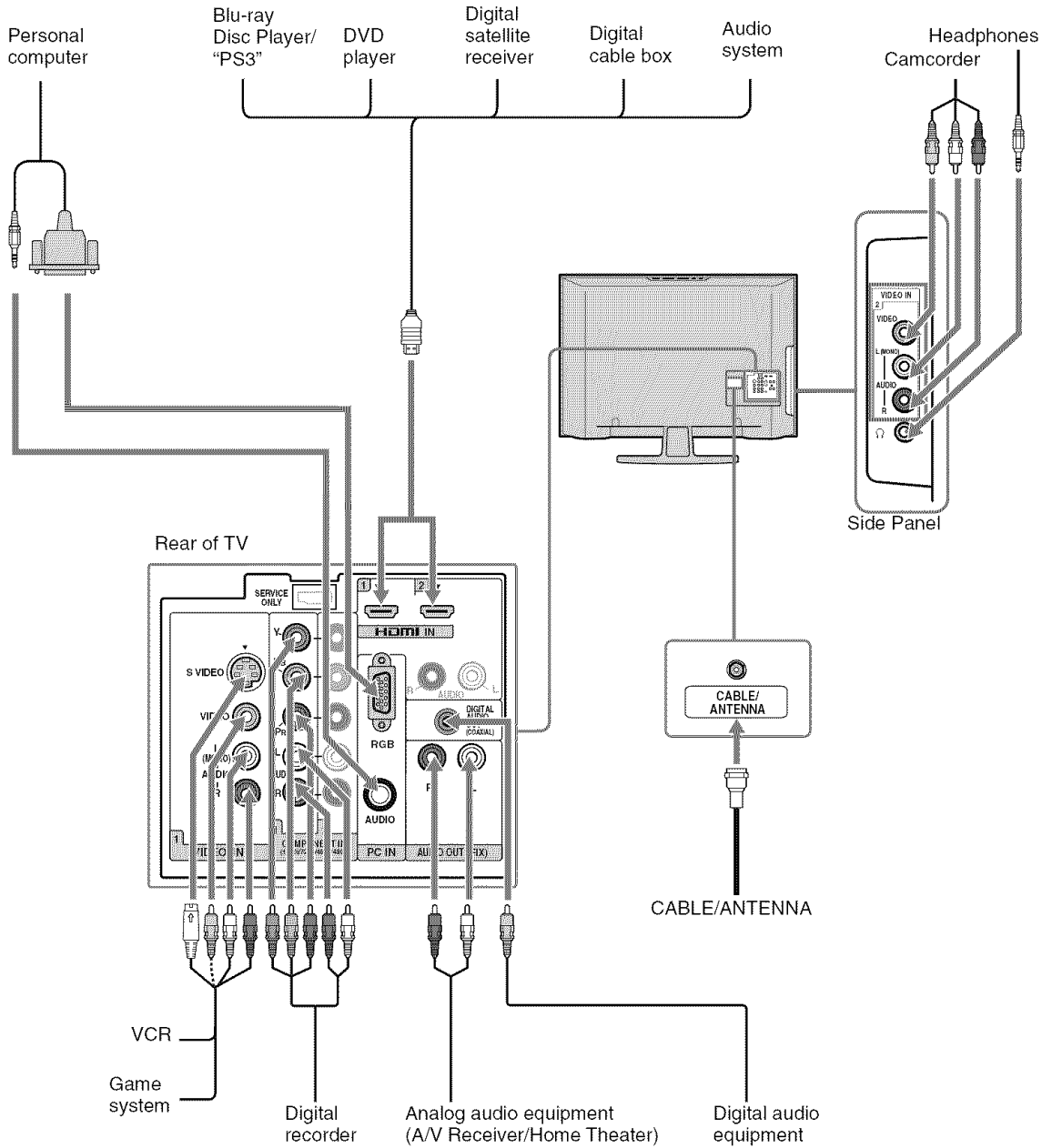



• Refer to the Quick Setup Guide (supplied) when connecting other equipment to your TV.

4. Setting Up the Channel List - Initial Setup

After you finish connecting your TV, you need to run **Initial Setup**, which automatically sets up available channels. The **Initial Setup** screen appears when you turn on your TV for the first time. If you do not want to set up the channels at this time, you can do it later by selecting the **Auto Program** option in the **Channel** menu (see page 33).

- 1 Press  to turn on the TV.
The **Initial Setup** screen appears.



- 2 Press  to highlight the desired language, then press .
- 3 Please connect cable or antenna, then select **Yes** to run **Auto Program**.



- If you want to run **Auto Program** later, select **No**.
 - If you have cable and antenna available, please connect cable first.
 - **IMPORTANT: You must perform Auto Program after cable or antenna is connected. If you cancel Auto Program some channels may not be available.**
- 4 Follow the help text provided on the screen to run **Auto Program**. **Auto Program** will scan for available channels from signal source directly connected to the TV's CABLE/ANTENNA input.
 - 5 When **Auto Program** is complete, select **OK** to finish the **Auto Program** process.

To run Auto Program at a later time

- Use the **Auto Program** feature at **Channel** menu as described on page 33.

To display the picture in your preferred aspect ratio

- Select the proper **Wide Mode** as described on pages 23 and 32.



- You may want to set up convenient features such as **Favorites** (see page 28), **Show/Hide Channels** (see page 33), **Label Channels** (see page 33) when **Auto Program** is completed.

Exploring Fun Features

Using BRAVIA Theatre Sync™ with Control for HDMI

This TV is equipped with BRAVIA Theatre Sync™. The **Control for HDMI** function enables BRAVIA Theatre Sync to allow communication between Sony TV's and Sony equipment. Only Sony equipment with **Control for HDMI** capability is supported.

To connect Sony equipment with Control for HDMI

Use an HDMI cable that bears the HDMI logo for connection. See pages 14 to 17 or see the HDMI connection shown in the Quick Setup Guide provided with the TV documentation.

Setting the Control for HDMI

In order for the function of **Control for HDMI** to operate, the TV and other Sony equipment with **Control for HDMI** function must be setup (see page 38). For other equipment, refer to the operating instruction for that equipment.

Control for HDMI available with your TV

The following operations are available after you connect the Sony equipment with **Control for HDMI** function to your TV:

- Automatically turn off the connected equipment when you turn off the TV.
- The TV will automatically turn on and tunes to the respective HDMI input when the connected equipment is turned on by One-Touch-Play.
- Equipment listed under **External Inputs** will turn on automatically when selected.

When you connect a Sony A/V receiver with BRAVIA Theatre Sync function to your TV, the following additional operation is possible:

- By pressing  on the remote control, it turns on and searches for an external audio system that supports BRAVIA Theatre Sync. When the Theatre Sync audio system is on, the internal speakers of the TV will turn off and the **Picture Mode** will change automatically to **Cinema**.

Remote Control and TV Controls/Indicators

Inserting Batteries

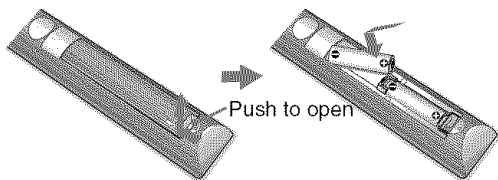

Insert two size AA batteries (supplied) by matching \oplus and \ominus on the batteries to the diagram inside the battery compartment of the remote control.

When Using the Remote Control

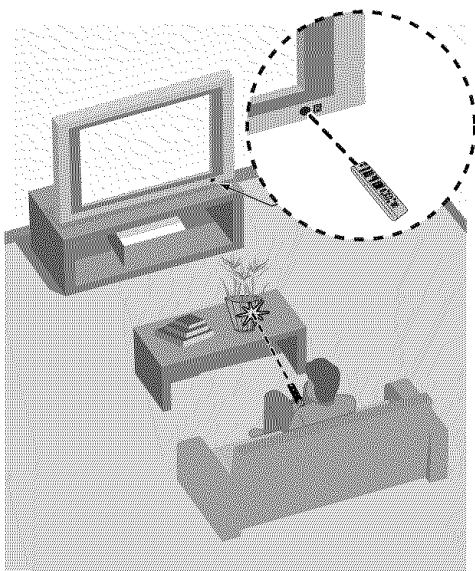

Follow the guidelines below

- Point your remote control directly at the IR sensor located on your TV.
- Make sure that no objects are blocking the path between the remote control and IR sensor on your TV.
- Fluorescent lamps can interfere with your remote control; try turning off the fluorescent lamps.
- If you are having troubles with the remote control, reinsert or replace your batteries and make sure that they are correctly inserted.

Remote Control



- The **5** and **CH +** buttons have a tactile dot. Use them as a reference when operating the TV.

Button	Description
1 DISPLAY	Press once to display the information pertaining to the channel and/or program when available. The OSD (On Screen Display) will time out in a few seconds or press again to immediately turn off the display.
2 SLEEP	Press repeatedly until the TV displays the time in minutes (Off, 15, 30, 60 or 120 minutes) that you want the TV to remain on before shutting off. To cancel Sleep Timer , press SLEEP repeatedly until Off appears.
3 THEATER	Press to turn on and off the Theater Mode . The picture settings will be set for a cinema-like experience and the audio will be switched to the audio output of the attached speakers of your BRAVIA Theatre Sync audio system. Your BRAVIA Theatre Sync audio system must be connected by an HDMI connection to your TV (see page 14 for details).
4 SOUND	Press repeatedly to step through the Sound Mode settings: Dynamic, Standard, Game, Clear Voice, Custom . These Sound Mode settings can be also accessed in the Sound menu (see page 31).
5 PICTURE	Press repeatedly to cycle through the available picture modes: Vivid, Standard, Cinema . The picture modes can also be accessed in the Picture menu. For details, see page 30.

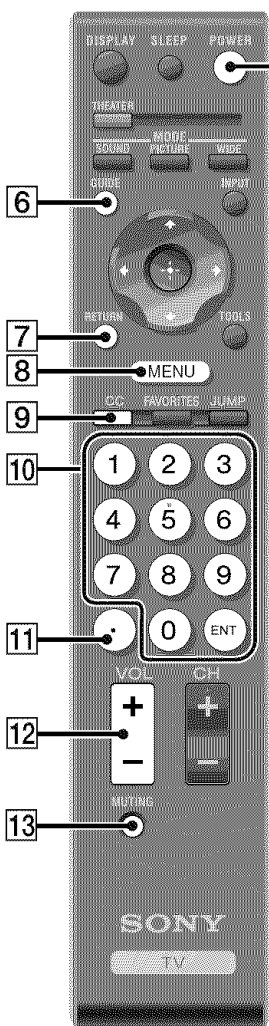

Button	Description
--------	-------------

6 GUIDE <i>(For all channels including Digital/Analog channels)</i>	Press to display the Guide when you are watching channels (if it is available from the station). Using the Guide The Guide allows you to select the channels from a channel list; also provides information about the current program being shown on each channel.
--	---

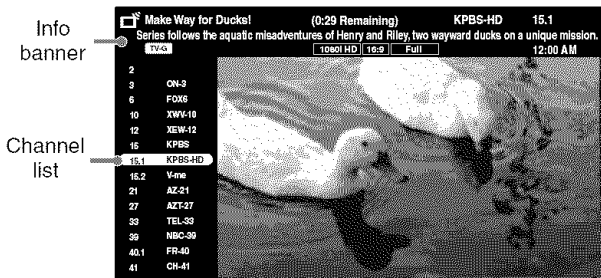

- Program information in the guide is provided by the broadcasters. As a result, it may sometimes include only the channel number, without a program title or description.

7 RETURN	Press to go back to the previous screen or exit from the screen when displaying menu items and settings.
8 MENU	Press to display the menu with TV functions and settings. See "Using TV Menus" on page 27.
9 CC	Press to turn on and off the Closed Captions (CC) . To change or customize the CC display, see page 37.
10 0-9/ENT	Press (0)-(9) to select a channel; the channel changes after few seconds. Press (ENT) to change channels immediately.
11	Use with (0)-(9) and (ENT) to select digital channels. For example, to enter 2.1, press (2) , (.) , (1) and (ENT) .
12 VOL +/-	Press to adjust the volume.
13 MUTING	Press to mute the sound. Press again or press VOL + to restore the sound.
14 POWER	Press to turn on and off the TV.







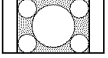

Button	Description
--------	-------------

15 WIDE

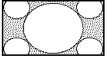
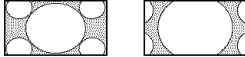
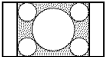
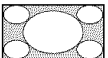
Press repeatedly to step through the **Wide Mode** settings: **Wide Zoom**, **Normal**, **Full**, **Zoom**. The **Wide Mode** settings can be also accessed in the **Screen** menu (see page 32).









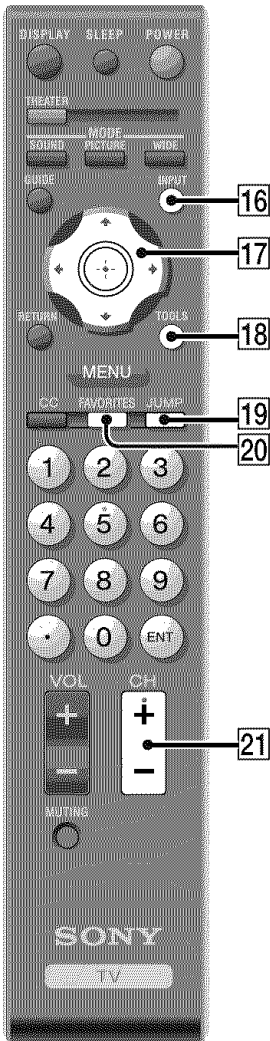





Changing the Wide Screen Mode

4:3 Original source Standard-definition source	16:9 Original source High-definition source
	
↓	↓
Wide Zoom 	Wide Zoom 
Normal 	Normal This mode is not available
Full 	Full 
Zoom 	Zoom 



- When the TV receives a 720p or 1080i signal, **Normal** cannot be selected.



Button	Description
16 INPUT	Press to display the list of External Inputs and TV mode. Press repeatedly to toggle through the inputs.  <ul style="list-style-type: none"> See page 37 (Label Inputs) on setting up the External Inputs labels.
17 	Press  to move the on-screen cursor. Press  to select/confirm an item.
18 TOOLS	This button supports different functions depending on the condition. When PC input is active, press  to view a channel at the same time as a PIP (picture in picture) screen (see page 29 for details). When antenna input is active and the broadcast includes Regional Digital Ratings, press  to view the list of special ratings. When an HDMI controlled equipment is active, press  to access the equipment menu, if the equipment supports the function.
19 JUMP	Press to alternate between two channels. The TV will alternate between the current channel and the last channel tuned with the buttons  -  and  on the remote control.
20 FAVORITES	This feature lets you create and choose a list of up to 8 favorite channels. Press  to select the option Add to Favorites , and press  to add the current channel to your Favorites list.  <ul style="list-style-type: none"> Your Favorites list will be cleared each time you run Auto Program (see pages 18 and 33).
21 CH +/-	Press to scan through channels. To scan quickly through channels, press and hold down either  or  .

TV Controls/Indicators

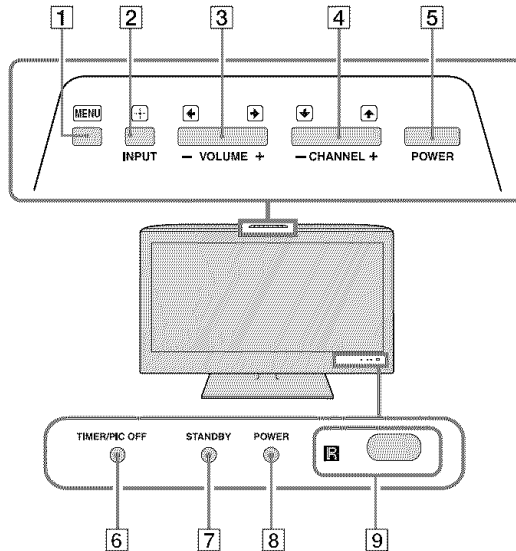

Item	Description
1 MENU	Press to display the menu with TV functions and settings (see “Using TV Menus” on page 27).
2 INPUT	Press to display the External Inputs list, toggle through the list and select your desired input. In the menu screen, this button serves as confirming the selection or setting.
3 - VOLUME +	Press to adjust the volume. In the menu screen, these buttons serve as left/right buttons.
4 - CHANNEL +	Press to scan through channels. In the menu screen, these buttons serve as up/down buttons.
5 POWER	Press to turn on and off the TV.
6 TIMER/PIC OFF LED	Lights up in amber when the timer is set. When the timer is set, this LED will remain lit even if the TV is turned off. For details, see page 38. If the LED blinks in red continuously, this may indicate the TV needs servicing (see contacting Sony information on the back cover). Lights up in green when the Backlight feature is activated (see page 31).
7 STANDBY LED	Light up in red when your TV is in PC standby mode.
8 POWER LED	Lights up in green when the TV is turned on.
9 (IR) Infrared Receiver Light Sensor	Receives IR signals from the remote control. Senses room light level and adjusts the screen brightness accordingly (see page 30 for details). Do not put anything near the sensor, as its function may be affected.



- Make sure that the TV is turned off before unplugging the power cord. Unplugging the power cord while the TV is turned on may cause the POWER LED to remain lit for up to 20 seconds or may cause the TV to malfunction.

Using TV Menus

MENU provides one button access for controlling your TV. It enables you to perform a variety of tasks intuitively with a control panel on the screen.

Navigating through TV Menu

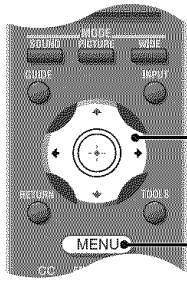

- 1 Press **MENU** on the remote control to display the menu options.
- 2 To highlight a menu option press **←**, then press **↑/↓** to go through the menus.
- 3 To select an option press **⊕** or **→**.
- 4 Press **↑/↓** to select or adjust your desired option, then press **⊕**.
- 5 To exit press **MENU**.

Menu Descriptions

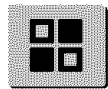

Shortcuts

The **Shortcuts** menu lets you select: **External Inputs, Favorites**, and have shortcuts to **Wide Mode, Clock/Timers, Parental Lock, Closed Captions (CC)** and **Cable**; you can also select **PC-PIP** function from this menu.

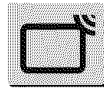

Channel

The **Channel** menu is used to provide maintenance to the channel options. Select from: **Favorites, Cable, Add Digital Channels, Auto Program, Show/Hide Channels, Label Channels** or **Diagnostics**.



Picture

The **Picture** menu is used to fine tune the image quality and allows you to customize several parameters for optimal viewing. Select from: **Picture Mode, Backlight, Picture, Brightness, Color, Hue, Color Temp** (Color Temperature), **Sharpness, Advanced Settings** or **Reset**.



Parental Lock

The **Parental Lock** feature allows you to set up the TV to block programs according to their content and rating levels; use **⊖-⊕** on the remote control to enter a four-digit password. The first time you create a password, confirm the password by entering it again.



Sound

The **Sound** menu allows you to fine tune and change audio. Select from: **Sound Mode, Steady Sound, Treble, Bass, Balance, Speakers, Backlight, Alt. Audio/MTS** or **Reset**.

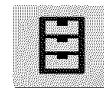

Setup

The **Setup** menu provides you additional features like: **Closed Captions (CC), Info Banner, Label Inputs, Skip Inputs, Clock/Timers, Language, Auto Sort Control, Control for HDMI, Update Control for HDMI List** or **Product Support**.

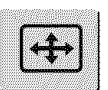



Screen

The **Screen** menu allows you to change the proportions of the screen. Select from: **Wide Mode, Auto Wide, 4:3 Default, Vertical Center, Vertical Size** or **Phase**.



Using the Shortcuts Menu

External Inputs	<p>This feature lets you select the external inputs connected to your TV.</p> <ol style="list-style-type: none">1 Press ▲/▼ to choose an external input from the list of 8 inputs.2 To select press (+). <p></p> <ul style="list-style-type: none">• To exit from external inputs list, press MENU.• To change external inputs again, repeat steps 1-2.• To go back to channels, press CH +/- to go through the channels or repeat steps 1-2 and select TV; or press FAVORITES to select a channel from your Favorites list.• You can also access the External Inputs list directly by pressing INPUT without having to navigate through the Menu.
Favorites	<p>This feature lets you create and choose a list of up to 8 favorite channels.</p> <p>Press ▲/▼ to select the option Add to Favorites and press (+) to add the current channel to your Favorites list.</p> <p></p> <ul style="list-style-type: none">• You can also press FAVORITES to see your Favorites channel list.
Wide Mode	<p>This option is a direct shortcut to the Screen menu to adjust the picture size in the Wide Mode option (see page 32).</p>
Clock/Timers	<p>This option is a shortcut to adjust Clock/Timers on Setup menu (see page 38).</p>
Parental Lock	<p>This option is a shortcut to the Parental Lock menu which allows you to enter a password to block channels (see page 34).</p>
Closed Captions (CC)	<p>This option is a shortcut to Closed Captions (CC) screen on Setup menu (see page 37).</p>
Cable	<p>This option is a shortcut to adjust Cable settings on Channel menu (see page 33).</p>

PC-PIP

This **PIP** (Picture In Picture) feature provides PC input signal and TV channels, allowing you to view two pictures simultaneously. When you select this feature from **Shortcuts** menu, the **PC-PIP** will appear with a Sub Window to see TV channels at the same time.

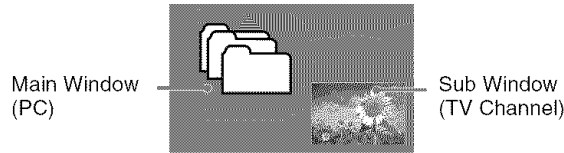

- You need a PC input signal to use **PC-PIP** function.
- To turn on or off the Sub Window on the screen press **TOOLS** from the remote control while using the PC input.
- You can also select **PC** input from the **External Inputs** list. Press **MENU**, select **External Inputs**, then select **PC** input from the list.

To change channels in the Sub Window

Press **CH +/-** to change the channels or enter the channel number using the **0**-**9** numeric buttons.

To Exit from PC-PIP (PC input)

- 1 Press **MENU** and select **External Inputs** on the **Shortcuts** menu.
- 2 From **External Inputs** list, select **TV** input to return to TV Channels.



- To exit from **PC-PIP**, you can also select a channel from your **Favorites** channels list on the **Shortcuts** menu.
- When the PC input signal is selected with the Sub Window active, you can only see TV channels; other external inputs are not available for this view (like VCR/DVD).
- **Closed Captions (CC)** is not available in the Sub Window.
- **Parental Lock** feature will work in the Sub Window, a padlock will appear on the blocked channels.











(Continued)



Using the Picture Menu





Picture Mode <i>Customized picture viewing</i>	Vivid	For enhanced picture contrast and sharpness.
	Standard	For standard picture settings. Recommended for home entertainment.
	Cinema	For viewing film-based content. Most suitable for viewing in a theater-like environment.
Backlight	Press ◀/▶ to brighten or darken the backlight, then press (+) to set.	
Picture	Press ◀/▶ to increase or decrease picture contrast, then press (+) to set.	
Brightness	Press ◀/▶ to brighten or darken the picture, then press (+) to set.	
Color	Press ◀/▶ to increase or decrease color intensity, then press (+) to set.	
Hue	Press ◀/▶ to increase or decrease the green or red tones, then press (+) to set.	
Color Temp (Color Temperature)	Cool	Gives the white colors a bluish tint.
	Neutral	Gives the white colors a neutral tint.
	Warm 1, 2	Gives the white colors a reddish tint.
Sharpness	Press ◀/▶ to sharpen or soften the picture, then press (+) to set.	
Advanced Settings	Noise Reduction	Reduces the noise level of connected equipment, and the CABLE/ANTENNA input.
	Black Corrector	Enhances black areas of the picture for stronger contrast.
	Gamma	Adjusts the balance between the light and dark areas of the picture.
	Clear White	Emphasizes white and light colors.
	Live Color	Makes colors more vivid and reproduces clear skin tones.
	Light Sensor	Select On to enable the automatic picture (screen) brightness control. The light sensor measures the room brightness which allows the TV to automatically adjust the backlight brightness based on the picture settings and the ambient room light conditions.
		 <ul style="list-style-type: none"> • Be sure not to put anything around the sensor, as its function may be affected. • In low light the range of the backlight control is reduced when Light Sensor is set to On.
Reset	Resets the current Picture Mode setting to factory default values.	

Using the Sound Menu

Sound Mode	Dynamic	Enhances the sound of action movies, sports events and musical videos.
	Standard	Standard sound optimized for home use.
	Game	Enhances the video games sound.
	Clear Voice	Enhances the voice sound; recommended for television news and documentary programs.
	Custom	Allows you to customize Treble and Bass sound settings.
Steady Sound	On	Stabilizes the volume across all programs and commercials.
	Off	Turns off Steady Sound .
Treble	Press   to increase or decrease higher-pitched sounds, then press  to set.	
Bass	Press   to increase or decrease lower-pitched sounds, then press  to set.	
Balance	Press   to emphasize left or right speaker balance, then press  to set.	
Speakers	Select to turn on or off the internal speakers.	
Backlight	Turns off the Backlight to conserve power while the audio is left on.	
Alt. Audio/MTS	This Audio feature for current program lets you select from 8 options of alternate audio (if it is available). You can select from English , Español (Spanish), Français (French) or Audio 4, 5, 6, 7, 8 audio available options.	
	 <ul style="list-style-type: none"> • Alternate Audio is disabled for analog signals and for digital signals that do not have alternate audio streams. 	
	Mono	Select for mono reception. Use to reduce noise during weak stereo broadcasts.
	Stereo	Select for stereo reception when viewing a program broadcast in stereo.
	Auto SAP	Select to automatically switch the TV to second audio programs when a signal is received. If no SAP signal is present, the TV remains in Stereo mode.
Reset	Resets the current Sound settings to factory default values.	
 <ul style="list-style-type: none"> • To customize Treble and Bass sound settings, you must select Custom on Sound Mode. 		



Using the Screen Menu

Wide Mode	These options allow you to change the proportion of the screen.
Wide Zoom	Select to enlarge the picture uniformly.
Normal	Select to display 4:3 pictures in original size when the original source is 4:3.
	<ul style="list-style-type: none"> • Normal is not available when you are watching 1080i or 720p in high-definition source.
Full	Select to enlarge the picture horizontally to fill the screen when the original source is 4:3 (standard-definition source). When the original source is 16:9 (high-definition source), select this mode to display 16:9 picture in original size.
Zoom	Select to enlarge the original picture without distorting the aspect ratio.
	<ul style="list-style-type: none"> • If you press  on the remote control, you can also select these modes directly.
Auto Wide	
On	Select to have the screen automatically change to the screen mode based upon program's content. Typically this requires special setup on DVD equipment's menu. If frequent screen changes are disturbing to you, select Off .
Off	Select to turn off the Auto Wide option. Choose a screen mode from the Wide Mode option.
4:3 Default	Select the default Screen Mode to use for 4:3 sources.
Wide Zoom	Select to enlarge the 4:3 picture to fill the 16:9 screen, keeping the original image as much as possible, with minimal distortion.
Normal	Select to display the 4:3 picture in its original size.
Full	Select to enlarge the picture horizontally to fill the screen when the original source is 4:3 (standard-definition source).
Zoom	Select to enlarge the original picture without distorting the aspect ratio.
Off	To turn Off automatic size for 4:3.
Vertical Center	Allows you to move the position of the picture up and down.
Vertical Size	Allows you to adjust the vertical size of the picture.
Phase	Adjusts to fine tune overall sharpness.
	<ul style="list-style-type: none"> • Phase is disabled when the TV is receiving a different video input than PC.



Using the Channel Menu

Favorites

Lets you set up a list of up to 8 of your favorite channels.

Press $\blacktriangle/\blacktriangledown$ to select the option **Add to Favorites** and press \oplus to add the current channel to your **Favorites** list.

To select a favorite channel from the list, press $\blacktriangle/\blacktriangledown$ to go through the list and \oplus to select the channel.



- To exit press **MENU**.
- To quickly access the **Favorites** channel list, press  when there is no menu on the screen.

Cable

On Select if you are receiving cable channels via cable TV provider.

Off Select if you are using an antenna.

Add Digital Channels

Select to add digital channels without replacing the original channel list. Be sure to set **Cable** setting to **On** or **Off** in **Channel** menu for the correct type of input signal you choose.

Auto Program

Automatically sets up the channel list on the TV for all receivable channels (Digital and Analog).



- Before starting **Auto Program**, be sure to turn to **On** or **Off** on **Cable** option in the **Channel** menu. When it is **On**, the TV will search cable channels; when it is **Off**, the TV will search over-the-air signals with an antenna connection.
- If you are using an A-B RF switch (not supplied) to switch between cable or antenna connection, be sure to select the correct **Cable** option to **On** or **Off** in the **Channel** Menu.

1 Select **Auto Program**.

2 Select **OK** to start **Auto Program**. When **Auto Program** is done, select **OK**.



- **IMPORTANT: You must perform Auto Program after cable or antenna is connected. If you cancel Auto Program some channels may not be available.**

Show/Hide Channels

Allows you to show or hide channels that appear when you use the **CH +/-** button.

1 Press $\blacktriangle/\blacktriangledown$ to scroll through the channels until you find the channel you want to show or hide.

2 Press \oplus to determine if the channel will be shown or hidden.

To show or hide more channels, repeat steps 1-2.



Label Channels

Allows you to assign labels to channel numbers.

1 Press $\blacktriangle/\blacktriangledown$ to scroll through the channel numbers. Then press \oplus to select the channel number that you want to assign a label.

2 Press $\blacktriangle/\blacktriangledown$ to move through the label characters (A-Z, 0-9) and press \oplus to select it. To move to the next character press $\blacktriangle/\blacktriangledown$. Repeat to add up to 7 characters to the label. Then select **Enter** on screen to set it. To assign labels to more channels, repeat steps 1-2.



- To delete a character select  on screen.
- To have a space between characters select  on screen.
- To exit press **RETURN**.

Diagnostics

Allows to confirm the current channel performance indicator.

(Continued)

Using the Parental Lock

The **Parental Lock** feature allows you to block programs according to their content and rating levels and block channels (regardless of the programs). Password is necessary in setting up blocking. Use **0**-**9** on the remote control to enter a four digit password. The first time you create a password, confirm the password by entering it again.

To View Blocked Programs

Press **OK** when tuned to a blocked program, then enter the password. To reactivate the **Parental Lock** settings, turn off and on the TV.

Rating	Off	Turn Parental Lock Off . No programs are blocked from viewing based on their rating.
	Child	Maximum ratings permitted are: U.S: TV-Y, TV-G, G Canada: C, TV-Y
	Youth	Maximum ratings permitted are: U.S: TV-PG, PG Canada: C8+, PG, 8 ans+, TV-PG
	Young Adult	Maximum ratings permitted are: U.S: TV-14, PG-13 Canada: 14+, 13 ans+, TV-14
	Custom	Select to set ratings manually: U.S: See page 36 for details. Canada: See page 36 for details.



- If you are not familiar with the **Parental Guideline** rating system, you should select **Child**, **Youth** or **Young Adult** to help simplify the rating selection. To set more specific ratings, select **Custom**.

Digital Rating <i>(Available only in U.S.A. where advanced ratings exist)</i>	Off	Turn Digital Rating off. No programs containing digital ratings are blocked from viewing.
	Custom	Select to customize the Parental Lock with downloadable digital ratings.
	Clear All	Select to clear the downloaded ratings. To cancel just select Cancel .

Unrated <i>(Available only when Country is set to U.S.A.)</i> <i>Block programs or movies that are broadcast without a rating</i>	Allow	Allows programs and movies that are broadcast without a rating.
	Block	Blocks all programs and movies that are broadcast without a rating.

 • If you block unrated TV programs, be aware that the following types of programs may be blocked: programs broadcast from another country, emergency broadcasts, political programs, sports, news, public service announcements, religious programs and weather.

Channel Block	Allows you to block channels regardless of program ratings. The password needs to be set up prior to blocking channels. The blocked channel can only be viewed by entering the correct password.
	To block a channel
	Press ▲/▼ to go through the channels and press (+) to Block or Allow channels.
	To view a blocked channel
	Press (ENT) when tuned to a blocked program, then enter the password. To reactive the Parental Lock settings, turn off and on the TV.
External Input Block	Allows you to block individual video inputs.
	Press ▲/▼ to scroll through the video inputs and press (+) to Block or Allow .
Change Password	Select to change your password. Use (0)-(9) buttons to select a four digit password; to confirm password enter it again.  • You need your password for any future access into the Parental lock settings. If you lose your password, see “Lost Password” on page 41.
Select Country	U.S.A. Select to use U.S.A. ratings.
	Canada Select to use Canadian ratings.

Custom Rating System Chart

US Models: Selecting Custom Parental Lock Rating Options

To select custom rating options for the U.S., select **U.S.A.** in the **Select Country** setting (see page 35).

Movie Rating	G	All children and general audience.
	PG	Parental guidance suggested.
	PG-13	Parental guidance for children under 13.
	R	Restricted viewing, parental guidance is suggested for children under 17.
	NC-17 and X	No one 17 or under allowed.
TV Rating	Age-Based Ratings	
<i>Block programs by their rating, content or both</i>	TV-Y	All children.
	TV-Y7	Directed to children age 7 and older.
	TV-G	General audience.
	TV-PG	Parental guidance suggested.
	TV-14	Parents strongly cautioned.
	TV-MA	Mature audience only.
	Content-Based Ratings	
	FV	Fantasy violence.
	D	Suggestive dialogue.
	L	Strong language.
S	Sexual situations.	
V	Violence.	
		<ul style="list-style-type: none"> To ensure maximum blocking capability, set the Age-Based Ratings.

Canadian Models: Selecting Custom Parental Lock Rating Options

To select custom rating options for Canada, select **Canada** in the **Select Country** setting (see page 35).

English Rating	C	All children.
	C8+	Children 8 years and older.
	G	General programming.
	PG	Parental guidance.
	14+	Viewers 14 and older.
	18+	Adult programming.
French Rating	G	General programming.
	8 ans+	Not recommended for young children.
	13 ans+	Not recommended for ages under 13.
	16 ans+	Not recommended for ages under 16.
	18 ans+	Programming restricted to adults.
U.S.A. Rating	See TV Rating under U.S.A. above for details.	

Using the Setup Menu

Closed Captions (CC) Allows you to select from several closed captions modes (for programs that are broadcast with closed captioning).

Select: **Off** (to turn off **Closed Captions**), **On** (to turn on **Closed Captions**), or **Program** (to program **Closed Captions**).

Programming Closed Captions

If you select the **Program** option under **Closed Captions**, you can change the following settings:





Basic	Allows you to select basic closed caption options (EIA-608). CC1, CC2, CC3, CC4 Text1, Text2, Text3, Text4	Displays a printed version of the dialog or sound effects of a program (should be set to CC1 for most programs). Displays network/station information presented using either half of the whole screen (if available).
Digital CC	Allows you to set digital closed captioning to Basic (digital EIA-608) or Advanced (digital EIA-708).	
Advanced	Allows you to select advanced digital (EIA-708) closed caption options. Select from the available options.	
Advanced Settings	Customize the Closed Captions (CC) displays with Character Style, Character Color, Character Size, Character Opacity, Character Align, Edge Color, Edge Type, Background Color, Background Opacity or Window Color .	



- **Closed Captions (CC)** can be turned on and off by pressing the  button on the remote control.

Info Banner Sets **On** or **Off**. When **On**: displays the program name and the remaining time (if the broadcaster offers this service). Displays for a few seconds when the channel is changed. If you don't want to display the **Info Banner**, select **Off**.

Label Inputs Allows you to identify A/V equipment you connected to the TV, such as a VCR, DVD, etc. For example, if you have a DVD player connected to the VIDEO 1 input, you can select the label DVD for the VIDEO 1 input. Then when you press  to change inputs, the label you assigned to that input appears on screen.

- 1 Press  to highlight the input (from 1 to 6) to which you want to assign a label, then press  to select it.
- 2 Press  to highlight one of the displayed labels, then press  to select it.

You can select from the following labels for each input:

DVD, VCR, Blu-ray, Cable Box, Satellite, DVR, Game, Camcorder or **Custom** (to customize, follow the same steps of **Label Channels** on page 33).

Skip Inputs Useful to disable inputs to which no equipment is connected.

Clock/Timers	Sleep	Set the time in minutes (Off, 15, 30, 60 or 120 minutes) that you want the TV to remain on before shutting off automatically.
	Timer	<p>You can use the Timer to tune to a specific channel at a scheduled time.</p> <p>Select Off to turn off the timer (previous settings are saved). On to turn on the timer (previous settings are saved) or Program, to set the timer by Time, Duration, Days, Source, Channel and Volume that you want to tune to a specific channel at scheduled time.</p> <p>If you select Program, press ▲/▼ (change the values) or ◀/▶ (move through the options) to set the hour, minutes, AM/PM, duration, days, source, channel and volume.</p> <p>You can also set a channel by pressing 0-9 (numeric values) and ⓪ (if the channel is digital) on the remote control.</p> <p>To replace a channel press ▶ on the remote control, then press ◀ to go back to the channel selection and enter a new channel number.</p> <p> • Timer feature will be not available until you set the Current Time.</p>
	Current Time	<p>Select to set the current time (day, hour, minutes and AM/PM).</p> <ol style="list-style-type: none"> 1 Press + to select Current Time. 2 Press ▲/▼/◀/▶ to set day, hour, minutes and AM/PM. 3 Press MENU to exit.
Language		Select to display all on-screen settings in your language of choice: English, Español (Spanish), Français (French).
Auto Sort Control		Select On if you want to sort the Shortcuts menu and Inputs list, based on the most frequent selections; select Off if you don't want to sort.
Control for HDMI		Allows your TV to communicate with other equipment that supports Control for HDMI function.
Update Control for HDMI List		Update equipments list connected to the HDMI input.
Product Support		Provides information related to trouble shooting and contact information. Select OK to reset the TV to factory default values, or Cancel if you do not want to reset the TV to factory default values.

Other Information

Troubleshooting

If you have additional questions, service needs, or required technical assistance related to the use of your Sony TV, please visit our website or call one of the following numbers:

<http://www.sony.com/tvsupport>
 1-800-222-SONY(7669) for US Support
 1-877-899-SONY(7669) for Canadian Support

Condition	Explanation/Solution
No picture	
No picture.	<input type="checkbox"/> Confirm your external inputs list and make sure you select TV (cable/antenna channels). See page 28 for more details. <input type="checkbox"/> Perform Auto Program to add receivable channels that are not presently in the TV's memory (page 33). <input type="checkbox"/> If there is no signal, the screen saver will appear.
Cannot receive any channels.	<input type="checkbox"/> Make sure the power cord is connected securely. <input type="checkbox"/> Turn on the power of the TV. <input type="checkbox"/> Check antenna/cable connections. <input type="checkbox"/> Perform Auto Program to add receivable channels that are not presently in the TV's memory (page 33). • IMPORTANT: You must perform Auto Program after cable or antenna is connected. If you cancel Auto Program some channels may not be available.
TV is locked to one channel.	<input type="checkbox"/> Perform Auto Program to add receivable channels that are not presently in the TV's memory (page 33).
Cannot receive or select channels.	<input type="checkbox"/> To receive or select cable channels, make sure that Cable in Channel settings is set to On . To receive or select UHF channels over an antenna, make sure Cable is set to Off . Perform Auto Program to add receivable channels that are not presently in the TV's memory (page 33).
The TV turns off automatically.	<input type="checkbox"/> Check if Sleep is activated, or confirm the Duration setting of Timer (page 38). <input type="checkbox"/> If there is no signal, the TV will turn off automatically.
No picture from some video sources.	<input type="checkbox"/> Check the connection between the optional video equipment and the TV. <input type="checkbox"/> Press <input type="button" value="INPUT"/> on the remote control (page 24). <input type="checkbox"/> Press <input type="button" value="MENU"/> on the remote control. Select your desired input from the External Inputs list.
Poor picture	
Double images or ghosts.	<input type="checkbox"/> Check antenna/cable connections. <input type="checkbox"/> Check the antenna location and direction.
Only snow and noise appear on the screen.	<input type="checkbox"/> Check if the antenna is broken or bent. <input type="checkbox"/> Check if the antenna has reached the end of its serviceable life. (3-5 years in normal use, 1-2 years at the seaside.)
Dotted lines or stripes.	<input type="checkbox"/> Keep the TV away from noise sources such as cars, motorcycles, or hair-dryers. <input type="checkbox"/> If using 300 ohm twin lead, move the excess lead away from the TV or try using 75 ohm coaxial cable instead.

Condition	Explanation/Solution
No color/Dark picture/Color is not correct/The picture is too bright.	<input type="checkbox"/> Press PICTURE to select the desired picture mode (page 21). <input type="checkbox"/> Adjust the Picture Mode options in the Picture menu (page 30).
Noisy picture.	<input type="checkbox"/> Make sure that the antenna is connected using a 75-ohm coaxial cable (not supplied). <input type="checkbox"/> Keep the antenna cable away from other connecting cords. <input type="checkbox"/> To avoid TV interference, make sure to use an undamaged antenna cable.
No sound/Noisy sound	
Good picture, no sound.	<input type="checkbox"/> Check the volume control. <input type="checkbox"/> Press MUTING or VOL + so that “Muting” disappears from the screen (page 22). <input type="checkbox"/> Disconnect your headphones. <input type="checkbox"/> Set Speaker to On in the Sound menu (page 31). If it is set to Off , sound is not output from the TV’s speakers regardless of the TV’s volume control.
Audio noise.	<input type="checkbox"/> Make sure that the antenna is connected using a 75-ohm coaxial cable (not supplied). <input type="checkbox"/> Keep the antenna cable away from other connecting cords. <input type="checkbox"/> To avoid TV interference, make sure to use an undamaged antenna cable.
PC Input	
No Picture/No Signal.	<input type="checkbox"/> Confirm the PC is correctly connected to the TV in the PC IN (not supplied HD15 cable). <input type="checkbox"/> Ensure the output signal from the PC is one of the formats listed on page 16. <input type="checkbox"/> Turn the PC off. Confirm the PC connection and restart the PC. Plug and play will auto-detect the TV.
Poor picture.	<input type="checkbox"/> Adjust the resolution (see page 16). <input type="checkbox"/> Adjust Phase (see page 32).
General	
Wide Mode changes automatically.	<input type="checkbox"/> The current Wide Mode setting is automatically replaced with the 4:3 Default setting when you change the channel or video input, if 4:3 Default in the Screen menu is set to other than Off . If you want to lock in Wide Mode selected with WIDE on the remote control, set 4:3 Default to Off in the Screen menu (page 32). <input type="checkbox"/> Turn off the Auto Wide option in the Screen menu (see page 32).
Suddenly the picture gets smaller.	<input type="checkbox"/> The picture gets smaller during the commercials, this is due to the method the provider broadcasts their contents. When HD content channels switch to SD definition content (commercials), the picture may be small with a black border.
“Black box” on screen.	<input type="checkbox"/> You have selected a text option and no text is available (see page 37). To turn off this feature, set the Closed Captions option to Off . If you were trying to select closed captioning, select CC1 instead of Text1-4 .
Black bands appear at the top and bottom of the screen.	<input type="checkbox"/> Some wide screen programs are filmed in aspect ratios that are greater than 16:9 (this is especially common with theatrical releases). Your TV will show these programs with black bands at the top and bottom of the screen. For more details, check the documentation that came with your DVD (or contact your program provider). <input type="checkbox"/> Programs in 4:3 aspect ratio will have bands on left and right sides of the screen. To select full size see page 32.

Condition	Explanation/Solution
Certain programs on DVD or other digital sources display a loss of detail, especially during fast-motion or dark scenes.	<input type="checkbox"/> The compression used by certain digital broadcasts and DVDs may cause your TV's screen to display less detail than usual, or cause artifacts (small blocks or dots, pixelations) to appear on your screen. This is due to your TV's large screen and ability to show very fine detail, and is normal for certain digitally recorded programs.
Remote control does not operate.	<input type="checkbox"/> Check the polarity of the batteries or replace the batteries. <input type="checkbox"/> Point the remote control at the remote control sensor of the TV. <input type="checkbox"/> Fluorescent lamps can interfere with your remote control operation; try turning off the fluorescent lamps. <input type="checkbox"/> Keep the remote control sensor area clear from obstacles.
Some digital cable channels are not being displayed.	<input type="checkbox"/> Certain cable companies have limitations on the broadcast of digital cable channels. Check with your cable company for more information. <input type="checkbox"/> The digital cable channel may be set to Hidden in the Show/Hide Channels setting (see page 33).
Lost password.	<input type="checkbox"/> Select the Parental Lock menu, then enter the following master password: 4357. The master password clears your previous password and allows you to enter a new password (page 34).
How to reset the TV to factory settings.	<input type="checkbox"/> Turn on the TV. While holding down ▲ on the remote control, press POWER on the TV. Release the ▲ button. WARNING: Parental Lock password may be required if it has been created. The reset will clear all of your customized settings.

Specifications

Model	KDL-26M4000	KDL-32M4000	KDL-37M4000	KDL-40M4000
System				
Television system	NTSC: American TV standard ATSC (8VSB terrestrial): ATSC compliant 8VSB QAM on cable: ANSI/SCTE 07 2000 (Does not include CableCARD functionality)			
Channel coverage	Analog terrestrial: 2 - 69 / Digital terrestrial: 2 - 69 Analog Cable: 1-125 / Digital Cable: 1-135			
Panel system	LCD (Liquid Crystal Display) Panel			
Speaker output	10 W + 10 W			
Input/Output jacks				
Antenna	75-ohm external terminal for VHF/UHF			
VIDEO IN 1/2	S VIDEO (4-pin mini DIN)(VIDEO 1 only): Y: 1.0 Vp-p, 75 ohms unbalanced, sync negative / C: 0.286 Vp-p (Burst signal), 75 ohms VIDEO: 1 Vp-p, 75 ohms unbalanced, sync negative AUDIO: 500 mVrms (100% modulation) / Impedance: 47 kilohms			
COMPONENT IN 1/2	YPbPr (Component Video): Y: 1.0 Vp-p, 75 ohms unbalanced, sync negative / PB: 0.7 Vp-p, 75 ohms / PR: 0.7 Vp-p, 75 ohms / Signal format: 480i, 480p, 720p, 1080i AUDIO: 500 mVrms (100% modulation) / Impedance: 47 kilohms			
HDMI IN 1/2	HDMI: Video: 480i, 480p, 720p, 1080i / Audio: Two channel linear PCM 32, 44.1 and 48 kHz, 16, 20 and 24bits AUDIO: 500 mVrms (100% modulation) / Impedance: 47 kilohms			
DIGITAL AUDIO OUT (COAXIAL)	PCM 2.0 coaxial signal			
AUDIO OUT (FIX)	500 mVrms (100% modulation) / More than 500 mVrms (Fixed)			
PC IN	D-sub 15-pin, analog RGB, 0.7 Vp-p, 75 ohms, positive See the PC Input Signal Reference Chart on page 16.			
PC AUDIO INPUT	Stereo mini jack, 500 mVrms, 47 kilohms			
Headphones	Stereo mini jack / Impedance: ≥ 16 ohms			
Power and others				
Power requirement	120 V AC, 60 Hz			
Power consumption				
in use	135 W	155 W	190 W	245 W
in standby	All models less than 1 W			
Screen size (inches measured diagonally)	26	31.5 (32 class)	37	40
Display resolution (horizontal × vertical)	1,366 dots × 768 lines			
Speaker/Full range (2)	146 × 35 mm 5 3/4 × 1 3/8 inches			
Dimensions (W × H × D)				
with stand				
mm	675 × 511 × 242	809 × 584 × 242	931 × 656 × 279	997 × 691 × 279
(inches)	(26 5/8 × 20 1/8 × 9 5/8)	(31 7/8 × 23 × 9 5/8)	(36 3/8 × 25 7/8 × 11)	(39 3/8 × 27 1/4 × 11)
without stand				
mm	675 × 466 × 97	809 × 542 × 99	931 × 609 × 110	997 × 644 × 110
(inches)	(26 5/8 × 18 3/8 × 3 7/8)	(31 7/8 × 21 3/8 × 4)	(36 3/8 × 24 × 4 3/8)	(39 3/8 × 25 3/8 × 4 3/8)
wall-mount hole pattern				
(mm)	200 × 100	200 × 200	300 × 300	300 × 300
Mass				
with stand				
(kg/lb.)	12 kg / 27 lb.	16 kg / 36 lb.	20 kg / 44 lb.	24 kg / 53 lb.
without stand				
(kg/lb.)	10 kg / 22 lb.	14 kg / 31 lb.	17 kg / 38 lb.	21 kg / 47 lb.
Supplied accessories	Remote control RM-YD026 (1) / Size AA batteries (2) / Cable holder (1 attached to the Table-Top Stand) / Operating Instructions (1) / Quick Setup Guide (1) / Warranty Card (1) / Online Registration Card (U.S.A. and Canada only) (1) / Safety and Regulatory Booklet (1)			
Optional accessories	Headphones plug adapter / Connecting cables / Wall-Mount Bracket: SU-WL100 (KDL-26M4000), SU-WL500 (KDL-32M4000, KDL-37M4000, and KDL-40M4000) / 75-ohm coaxial cable / HD15-HD15 cable / Support Belt Kit / TV Stand: RHT-S10 (KDL-40M4000)			



- Design and specifications are subject to change without notice.

Index

0-9 button 22
4:3 Default 32

A

Add Digital Channels 33
Advanced Settings 30
Alt. Audio/MTS 31
AUDIO OUT jack, described 13
Auto Program 18, 33
Auto Sort Control 38
Auto Wide 32

B

Backlight 30, 31
Balance 31
Bass 31
BRAVIA Theatre Sync 19
Brightness 30

C

Cable 28, 33
Cable holder 8
CABLE/ANTENNA input, described 13
Canadian Models 36
CC button 22
CH+/- button 24, 25
Change Password 35
Channel Block 35
Clock/Timers 28, 38
Closed Captions (CC) 28, 37
Color 30
Color Temp (Color Temperature) 30
COMPONENT IN jack (1080i/720p/
480p/480i), described 13
Control for HDMI 38

D

Diagnostics 33
DIGITAL AUDIO OUT (Coaxial),
described 13
Digital Rating 34
DISPLAY button 21

E

English Rating 36
ENT button 22
External Input Block 35
External Inputs 28

F

Favorites 28, 33
FAVORITES button 24
French Rating 36

G

GUIDE button 22

H

HDMI IN jack, described 13
Headphone jack, described 12
Hue 30

I

Info Banner 37
Infrared Receiver (IR) 25
Initial Setup 18
INPUT button 24, 25
Installing the TV on a wall 8, 9, 10, 11

J

JUMP button 24

L

Label Channels 33
Label Inputs 37
Language 38
Light Sensor
Described 25

M

Menu
Channel 33
Parental Lock 34
Picture 30
Screen 32
Setup 37
Shortcuts 28
Sound 31
MENU button 22, 25
Movie Rating 36
MUTING button 22

P

Parental Lock 28, 34
PC IN 13
PC-PIP 29
Phase 32
Picture 30
PICTURE button 21
Picture Mode 30
POWER button 22, 25
POWER LED 25
Product Support 38

R

Rating 34
Remote Control 21, 22, 23, 24
Reset 30, 31, 41
RETURN button 22

S

S VIDEO jack, described 13
Select Country 35
SERVICE ONLY 13
Setting up channels 18
Sharpness 30
Show/Hide Channels 33
Skip Inputs 37
SLEEP button 21
SOUND button 21
Sound Mode 31
Speakers 31
STANDBY LED 25
Steady Sound 31

T

THEATER button 21
TIMER/PIC OFF LED 25
TOOLS button 24
Treble 31
Troubleshooting 39, 40, 41
Turning on/off the TV 22, 25
TV Rating 36

U

U.S.A. Rating 36
Unrated 34
Update Control for HDMI List 38
US Models 36

V

Vertical Center 32
Vertical Size 32
VIDEO/AUDIO (L/R) jacks, described
12, 13
VOL+/- button 22, 25

W

WIDE button 23
Wide Mode 28, 32

For Your Convenience

Please contact Sony directly if you:

- Have questions on the use of your television after reading your operating instruction manual and Quick Setup Guide
- Experience difficulty operating your television

Contact Sony Customer Support at:

<http://www.sony.com/tvsupport>

or to speak with a support representative:

United States

1-800-222-SONY (7669)

Canada

1-877-899-SONY (7669)

Sony will work to resolve your questions more quickly than your retailer or place of purchase.

Please Do Not Return the Product to the Store



<http://www.sony.net/>

Printed in U.S.A.