



44133

Freezer

Use & Care Guide

Congelador

Guía para su uso y cuidado

Congélateur

Guide d'utilisation et d'entretien

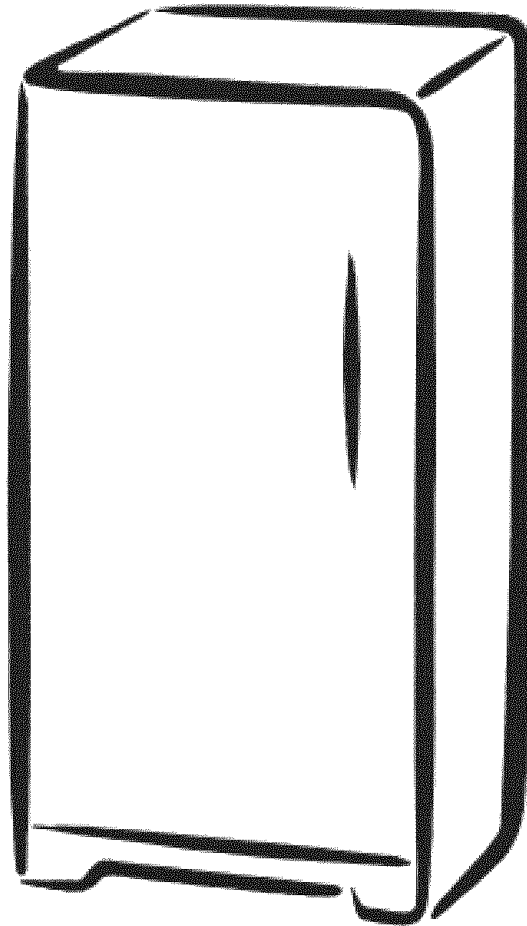

Sears, Roebuck and Co., Hoffman Estates, IL 60179 U.S.A.
Sears Canada, Inc., Toronto, Ontario, Canada M5B 2B8

www.sears.com
297226400 (Jan 2008)

ENGLISH

ESPAÑOL

FRANÇAIS

TABLE OF CONTENTS

Serial/Model Numbers	2
Important Safety Instructions	2-3
Kenmore PRO Appliance Warranty	3
Protection Agreements	4
Features at a Glance	5
First Steps	6-7
Setting the Temperature Control	7
Freezer Features	7-9
Energy Saving Tips	9
Power Failure/Freezer Failure	9
Ice Service	9-10
Care and Cleaning	10
Troubleshooting Guide	11-12
Sears Service	13
Sears Canada Customers	13

SERIAL / MODEL NUMBERS

READ AND SAVE THESE INSTRUCTIONS

This Owner's Guide provides specific operating instructions for your model. Use your freezer only as instructed in this guide. These instructions are not meant to cover every possible condition and situation that may occur. Common sense and caution must be practiced when installing, operating, and maintaining any appliance.

RECORD YOUR MODEL AND SERIAL NUMBERS

Record the model number and serial numbers in the space provided below. The serial plate is located on the left wall inside the freezer.

Model Number: 253 _____
 or 970 _____
 Serial Number: _____
 Purchase Date: _____

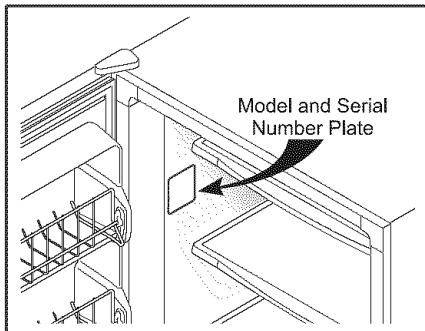

IMPORTANT SAFETY INSTRUCTIONS

READ ALL INSTRUCTIONS BEFORE USING THIS FREEZER.

⚠ WARNING FOR YOUR SAFETY

- Do not store or use gasoline or other flammable vapors and liquids in the vicinity of this unit or any other appliance. Read product labels for flammability and other warnings.
- Do not operate this product in the presence of explosive fumes.

⚠ WARNING CHILD SAFETY

- Destroy carton, plastic bags, and any exterior wrapping material immediately after the freezer is unpacked. Children should never use these items to play. Cartons covered with rugs, bedspreads, plastic sheets or stretch wrap may become airtight chambers and can quickly cause suffocation.
- Remove all staples from the carton. Staples can cause severe cuts, and destroy finishes if they come in contact with other appliances or furniture.
- An empty, discarded ice box, refrigerator or freezer is a very dangerous attraction to children.
- Remove or discard any spacers used to secure the shelves during shipping. Small objects are a choke hazard to children.
- Remove the door(s) of any appliance that is not in use, even if it is being discarded.

PROPER DISPOSAL OF YOUR REFRIGERATOR OR FREEZER

⚠ WARNING RISK OF CHILD ENTRAPMENT

Child entrapment and suffocation are not problems of the past. Junked or abandoned refrigerators or freezers are still dangerous - even if they will sit for "just a few days". If you are getting rid of your old refrigerator or freezer, please follow the instructions below to help prevent accidents:

- Remove the door(s).
- Leave shelves in place so children may not easily climb inside.
- Have the refrigerant removed by a qualified technician.

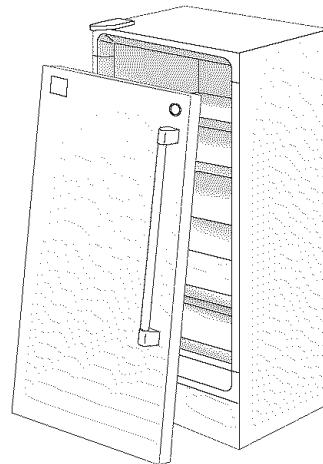

⚠ WARNING ELECTRICAL INFORMATION

These guidelines must be followed to ensure that safety mechanisms in the design of this freezer will operate properly.

- Refer to the serial plate for correct electrical rating. The power cord of the freezer is equipped with a three-prong grounding plug for protection against shock hazards. It must be plugged directly into its own properly grounded three-prong receptacle, protected with a 15 amp time delay fuse or circuit breaker. The power supply circuit must be installed in accordance with current edition of the National Electrical Code (NFPA 70) and local codes and ordinances. Consult a qualified electrician. Receptacles protected by Ground Fault Circuit Interrupters (GFCI) are NOT RECOMMENDED. **DO NOT USE AN EXTENSION CORD OR AN ADAPTER PLUG.**
- If the voltage varies by 10 percent or more, freezer performance may be affected. Operating the freezer with insufficient power can damage the motor. Such damage is not covered under the warranty. If you suspect your household voltage is high or low, consult your power company for testing.
- To prevent the freezer from being turned off accidentally, do not plug the unit into an outlet controlled by a wall switch or pull cord.
- Do not pinch, knot, or bend the power cord in any manner.

OTHER PRECAUTIONS

- Never unplug the freezer by pulling on the power cord. Always grip the plug firmly and pull straight out from the receptacle.
- Turning the control to "OFF" turns off the compressor but does not disconnect power to the light bulb or other electrical components.

⚠ WARNING

Avoid fire hazard or electric shock. Do not use an extension cord or an adapter plug. Do not remove any prong from the power cord.

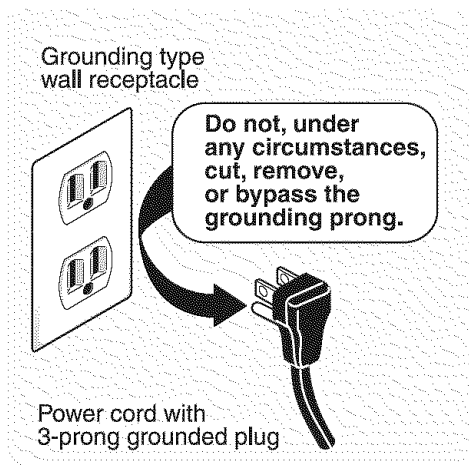

KENMORE PRO APPLIANCE WARRANTY

ONE YEAR LIMITED WARRANTY

When installed, operated and maintained according to all instructions supplied with the product, if this appliance fails due to a defect in material or workmanship within one year from the date of purchase, call 1-800-4-MY-HOME® to arrange for free repair.

LIMITED FIVE YEAR WARRANTY ON SEALED REFRIGERATION SYSTEM

For five years from the date of purchase, when this appliance is installed, operated, and maintained according to the instructions supplied with it, Sears will repair the sealed system (consisting of refrigerant, connecting tubing, and compressor), free of charge, if defective in material or workmanship.

If this appliance is used for other than private family purposes, this warranty applies for only 90 days from the date of purchase.

This warranty covers only defects in material and workmanship. Sears will NOT pay for:

1. Expendable items that can wear out from normal use, including but not limited to filters, belts, light bulbs and bags.
2. A service technician to instruct the user in correct product installation, operation or maintenance.
3. A service technician to clean or maintain this product.
4. Damage to or failure of this product if it is not installed, operated or maintained according to all instructions supplied with the product.
5. Damage to or failure of this product resulting from accident, abuse, misuse or use for other than its intended purpose.
6. Damage to or failure of this product caused by the use of detergents, cleaners, chemicals or utensils other than those recommended in all instructions supplied with the product.
7. Damage to or failure of parts or systems resulting from unauthorized modifications made to this product.

Disclaimer of implied warranties; limitation of remedies

Customer's sole and exclusive remedy under this limited warranty shall be product repair as provided

herein. Implied warranties, including warranties of merchantability or fitness for a particular purpose, are limited to one year or the shortest period allowed by law. Sears shall not be liable for incidental or consequential damages. Some states and provinces do not allow the exclusion or limitation of incidental or consequential damages, or limitations on the duration of implied warranties of merchantability or fitness, so these exclusions or limitations may not apply to you.

This warranty applies only while this appliance is used in the United States and Canada.

This warranty gives you specific legal rights, and you may also have other rights which vary from state to state.

Sears, Roebuck and Co., Dept. 817WA, Hoffman Estates, IL 60179

Sears Canada Inc., Toronto, Ontario, Canada M5B 2B8

ENGLISH

PROTECTION AGREEMENTS

In the U.S.A.

Master Protection Agreements

Congratulations on making a smart purchase. Your new Kenmore Pro® product is designed and manufactured for years of dependable operation. But like all products, it may require preventive maintenance or repair from time to time. That's when having a Master Protection Agreement can save you money and aggravation.

Purchase a Master Protection Agreement now and protect yourself from unexpected hassle and expense.

The Master Protection Agreement also helps extend the life of your new appliance. Here's what's included in the Agreement:

- ⚙️ **Expert service** by our 12,000 professional repair specialists
- ⚙️ **Unlimited service and no charge** for parts and labor on all covered repairs
- ⚙️ **"No-lemon" guarantee** – replacement of your covered product if four or more product failures occur within twelve months
- ⚙️ **Product replacement** if your covered product can't be fixed
- ⚙️ **Annual Preventive Maintenance Check** at your request – no extra charge
- ⚙️ **Fast help by phone** – phone support from a Sears technician on products requiring in-home repair, plus convenient repair scheduling
- ⚙️ **Power surge protection** against electrical damage due to power fluctuations
- ⚙️ **Rental reimbursement** if repair of your covered product takes longer than promised

Once you purchase the Agreement, a simple phone call is all that it takes for you to schedule service. You can call anytime day or night, or schedule a service appointment online.

Sears has over 12,000 professional repair specialists, who have access to over 4.5 million quality parts and accessories. That's the kind of professionalism you can count on to help prolong the life of your new purchase for years to come. Purchase your Master Protection Agreement today!

Some limitations and exclusions apply. For prices and additional information, call 1-800-827-6655.

Sears Installation Service

For Sears professional installation of home appliances and items like garage door openers, water heaters, and other major home items, in the U.S.A. call 1-800-4MY-HOME®.

In Canada

Maintenance Agreements

Your purchase has added value because you can depend on Sears HomeCentral® for service. With over 2400 Service Technicians and more than a million parts and accessories, we have the tools, parts, knowledge and skills to back our pledge:

We Service What We Sell.

Your Kenmore Pro® product is designed, manufactured and tested to provide years of dependable operation. But like all products, it may require service from time to time. The Sears Maintenance Agreement offers you an outstanding service program, affordably priced.

The Sears Maintenance Agreement

- Is your way to buy tomorrow's service at today's price.
- Eliminates repair bills resulting from normal wear and tear.
- Provides phone support from a Sears technician on products requiring in-home repair.
- Even if you don't need repairs, provides an annual Preventive Maintenance Check, at your request, to ensure that your product is in proper running condition.

Some limitations apply. For more information about concerning Sears Canada Maintenance Agreements, call 1-800-361-6665.

FEATURES AT A GLANCE

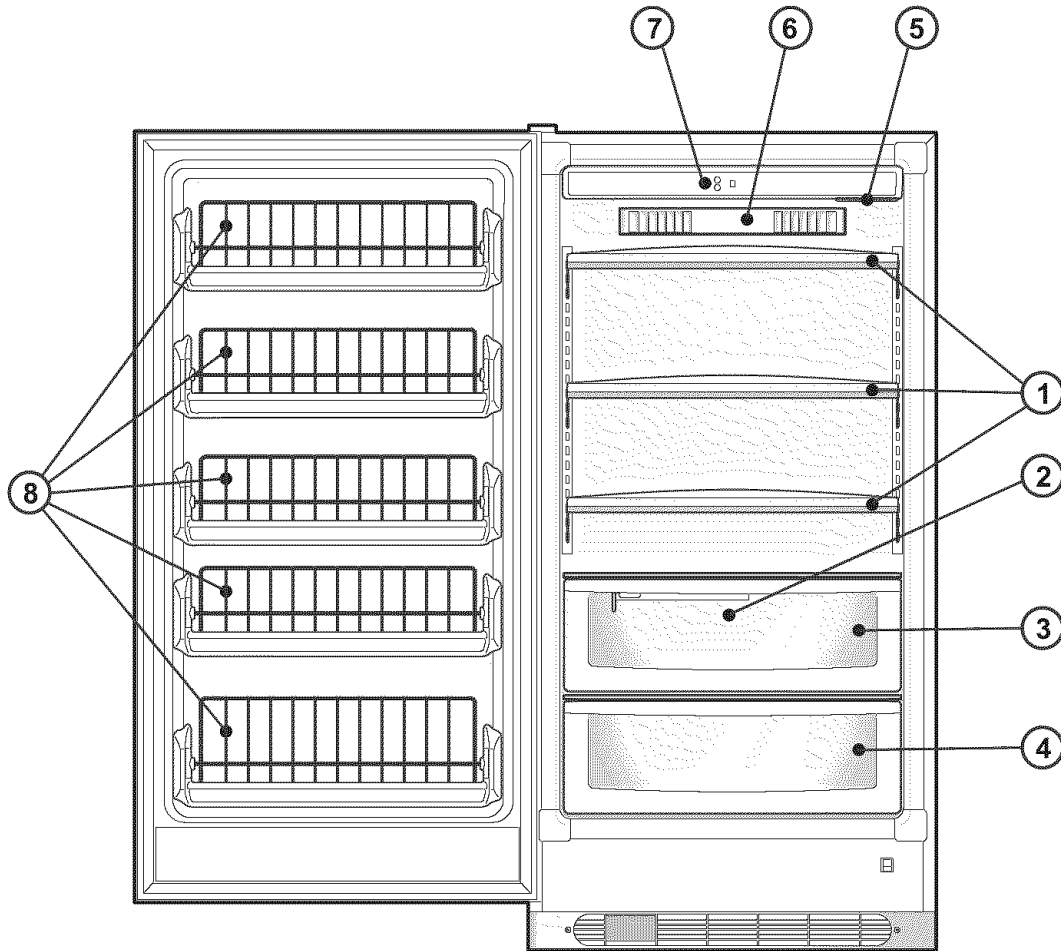

1	SPILL PROOF SLIDE OUT GLASS SHELVES	5	AIR FILTER
2	MID LEVEL LIGHTING (BACK OF CRISPER)	6	AIR DIFFUSER
3	UPPER CRISPER	7	ELECTRONIC CONTROLS
4	LOWER CRISPER	8	TILT-OUT SHELVES

FIRST STEPS

This Owner's Guide provides specific operating instructions for your model. Use the freezer only as instructed in this Owner's Guide. **Before starting the freezer, follow these important first steps.**

INSTALLATION

- Choose a place that is near a grounded electrical outlet. **DO NOT use an extension cord or an adapter plug.**
- For most efficient operation, the freezer should be located where surrounding temperatures will not drop below 40°F (5°C) or exceed 110°F (43°C).
- Allow the following clearances for ease of installation, proper air circulation, and electrical connections:

Sides	3/8 inch
Back & Top	1 inch
- Do not block the toe grille on the lower front of your freezer. Sufficient air circulation is essential for the proper operation of your freezer.

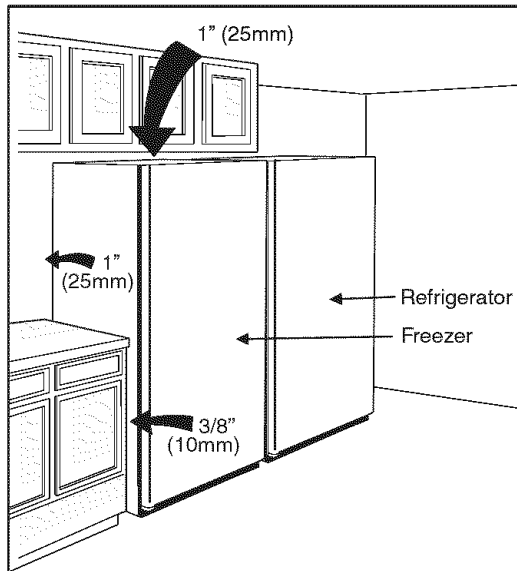

NOTE

The exterior walls of the freezer may become quite warm as the compressor works to transfer heat from the inside. Temperatures as much as 30°F warmer than room temperature can be expected.

DOOR OPENING

NOTE: If your freezer is placed with the door hinge side against a wall, you may have to allow additional space so the door can be opened wider.

LEVELING

The freezer must have all bottom corners resting firmly on a solid floor. The floor must be strong enough to support a fully loaded freezer. It is **VERY IMPORTANT** for your freezer to be level in order to function properly. If the freezer is not leveled during installation, the door may be misaligned and not close or seal properly, causing cooling, frost or moisture problems.

TO LEVEL FREEZER:

After discarding crating screws and wood base, use a carpenter's level to level the freezer from front to back. Adjust the plastic leveling feet in front, 1/2 bubble higher, so that the door closes easily when left halfway open.

LEVELING INSTRUCTIONS FOR ALL REFRIGERATOR / FREEZER PAIR:

- Remove two leg levelers provided in literature bag. While unit is lying on its back for wood skid removal, install both leg levelers in rear of unit.
- Level door of first unit using all four levelers and slide unit into place. Recheck for levelness and adjust if necessary.
- Measure distance from floor to bottom of door on first unit. Adjust and level second unit so door height matches.
- Leg Level Adjustments:
 - One full turn of all four leg levelers will raise door 5/32".
 - One full turn of both front leg levelers will raise door 3/16" and tilt top of door back 7/16".
 - One full turn of both rear leg levelers will lower door 1/32" and tilt top of door forward 7/16".
 - One full turn of both side leg levelers will raise door 3/16" and tilt top of door 3/8".
- Slide second unit into place leaving a minimum gap of 3/16" between units for door swing clearance.
- This last step may require at least one extraction of the second unit to properly align units in a "built-in" application.

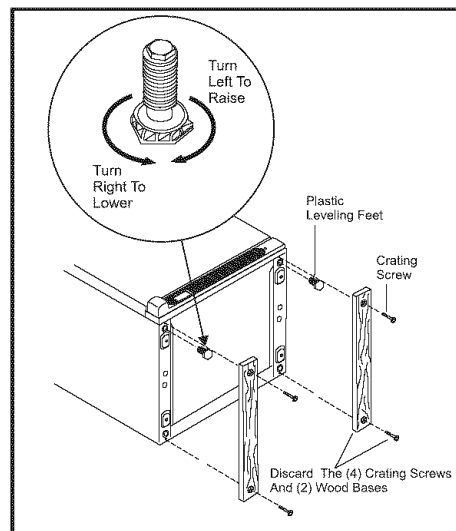

CAUTION

To allow door to close and seal properly, do not let food packages extend past the front of the shelves.

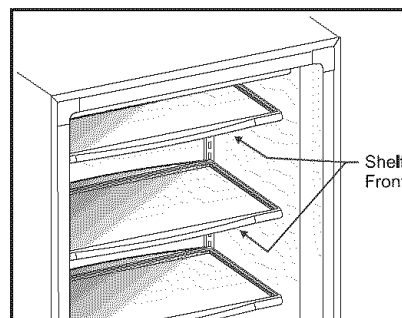

DOOR REMOVAL

If door must be removed:

- Unplug the unit
- Gently lay freezer on its back, on a rug or blanket.
- Remove two base screws and base panel. Remove wire from clips on bottom of cabinet, if required.
- Unplug connector, if required, by holding the cabinet connector in place and pulling the door connector out.
- Remove the bottom hinge screws.
- Remove the plastic top hinge cover.
- Remove the screws from the top hinge.
- Remove the top hinge from the cabinet.
- Remove the door and bottom hinge from the cabinet.
- To replace door, reverse the above procedures and securely tighten all screws to prevent hinge slippage.

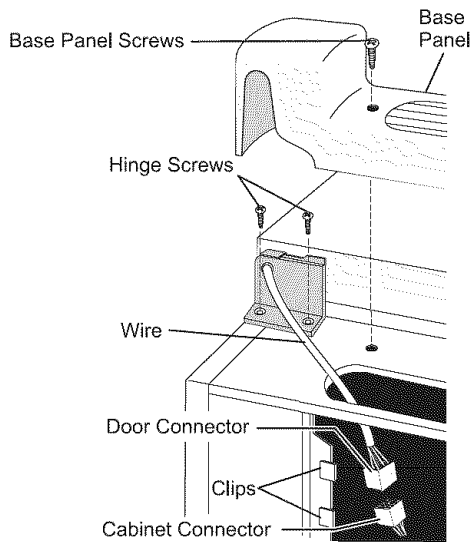

ICE MAKER INSTALLATION

If your freezer has an automatic ice maker, please refer to the insert in the bond pack that came with your freezer (**CONNECTING ICE MAKER TO WATER SUPPLY**) to correctly hook-up your ice maker.

SETTING THE TEMPERATURE CONTROL

COOL DOWN PERIOD

For safe food storage, allow four (4) hours for freezer to cool down completely. The freezer will run continuously for the first several hours.

ELECTRONIC TEMPERATURE CONTROL

The electronic temperature control is located inside the freezer. Temperature is factory preset to provide satisfactory food storage temperatures. However, the temperature control is adjustable to provide a range of temperatures for your personal satisfaction. To adjust the temperature setting, move the UP (▲) button for warmer temperature and DOWN (▼) button for colder temperature on the control panel. Allow several hours for the temperature to stabilize between adjustments.

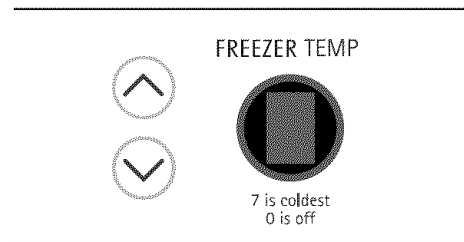

FREEZER FEATURES

INTERIOR LIGHTING

The light comes on automatically when the door is opened. The light bulb assembly is located on the back of the freezer control box. To replace the light bulb, turn the temperature control to "OFF" and unplug the electrical cord. Replace the old bulb with a bulb of the same type and wattage.

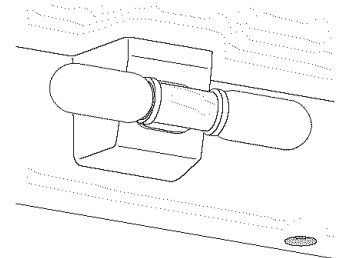

ENGLISH

SPILL PROOF SLIDE-OUT GLASS SHELVING

Multi-position adjustable slide out glass shelves can be moved to any position for larger or smaller packages. The shipping spacers that stabilize the shelves for shipping may be removed and discarded.

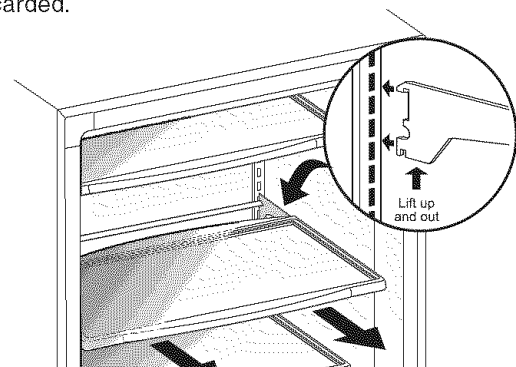

TO ADJUST THE SHELVES

NOTE

Cantilever shelves are supported at the back of the freezer.

- Lift front edge up.
- Pull shelf out
- Replace the shelf by inserting the hooks at rear of the shelf into the wall bracket. Lower the shelf into the desired slots and lock into position.

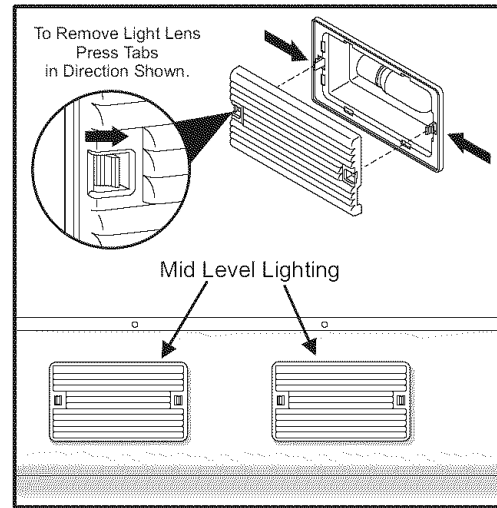
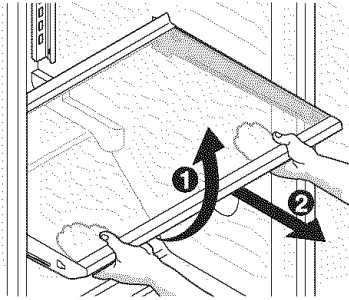

CRISPERS WITH ADJUSTABLE DIVIDERS

The crispers, located at the bottom of the freezer shelf, provide separate storage space for items that are difficult to store on freezer shelves.

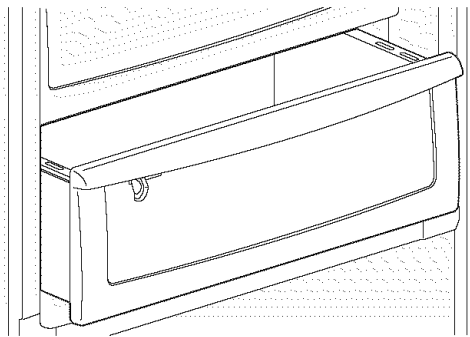

MID LEVEL LIGHTING

The mid level lighting is located at the back of the crispers. The lights come on automatically when the door is opened. To replace the light bulb, turn the temperature control to OFF and unplug the electrical cord. Remove the lens from the lamp housing by unsnapping it from the lamp housing using your fingers or a screwdriver. Be careful not to break the locking tabs on the lamp housing. Replace the old bulb with a bulb of the same type and wattage. To replace the lens, snap one side of the lens opening to the tab on the lamp housing. Then carefully attach the other side.

AIR FILTER

The air filter is located on the back of the control box. In general, you should change the air filter every six months to ensure optimal filtering of freezer odors. You may want to adjust this time period depending on the types and amounts of food you typically store in your freezer.

TO REPLACE THE AIR FILTER:

- Push the plastic bubble tab at the back of the control box housing. This releases the hinged bottom half to drop open.
- Remove the old filter and discard it.
- Unpackage the new filter and place it inside the hinged bottom half of the housing.
- Push the hinged bottom half upward until the tab snaps into closed position.

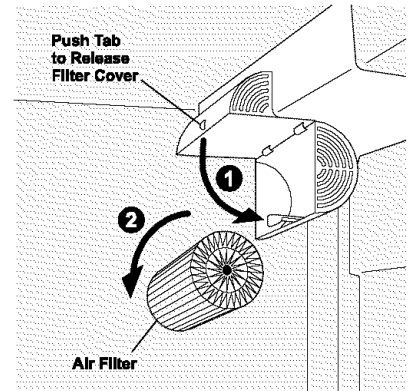

DOOR MOUNTED TEMPERATURE GAUGE

The door mounted temperature gauge displays the cabinet internal temperature.

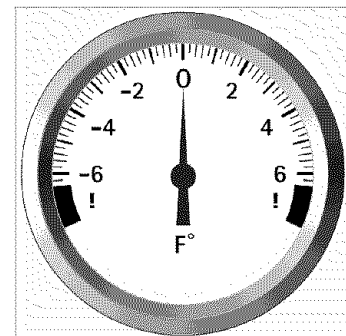

TILT - OUT SHELF

This shelf is located inside on the freezer door and provides additional storage space. To access an item, tilt the top of "basket" shelf down.

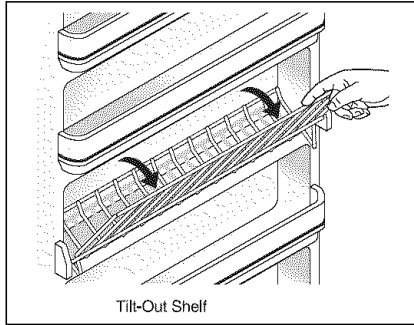

ENERGY SAVING TIPS

ENERGY SAVING IDEAS

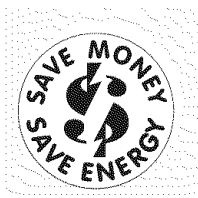

- Locate the freezer in the coolest part of the room, out of direct sunlight, and away from heating ducts or registers. Do not place the freezer next to heat-producing appliances such as a range, oven, or dishwasher. If this is not possible, a section of cabinetry or an added layer of insulation between the two appliances will help the freezer operate more efficiently.

- Level the freezer so that the door closes tightly.
- Refer to the "**SETTING THE TEMPERATURE CONTROL**" section for the suggested temperature control settings.
- Let hot foods cool to room temperature before placing them in the freezer. Overloading the freezer forced the compressor to run longer. Foods that freezer too slowly may spoil or lose quality.
- Do not overcrowd the freezer or block cold air vents. Doing so causes the freezer to run longer and use more energy.
- Be sure to wrap foods properly and wipe containers dry before placing them in the freezer. This cuts down on frost build-up inside the freezer.
- Freezer shelves should not be lined with aluminum foil, wax paper, or paper toweling. Liners interfere with cold air circulation, making the freezer less efficient.
- Organize the freezer to reduce door openings. Remove as many items as needed at one time and close the door as soon as possible.

VACATION AND MOVING TIPS

Short Vacations:

- Leave the freezer operating during vacations of less than three weeks.

Long Vacations:

- If the freezer will not be used for several months:
- Remove all food and unplug the power cord.
 - Clean and dry the interior thoroughly.
 - Leave the freezer door open slightly, blocking it open if necessary, to prevent odor and mold growth.

Moving: When moving the freezer, follow these guidelines to prevent damage:

- Disconnect the power cord plug from the wall outlet.
- Remove foods, then defrost, and clean the freezer.
- Secure all loose items such as base panel, baskets, and shelves by taping them securely in place to prevent damage.
- In the moving vehicle, secure freezer in an upright position to prevent movement. Also protect outside of freezer with a blanket, or similar item.

POWER FAILURE / FREEZER FAILURE

NOTE: Do not open freezer door unnecessarily if freezer is off for several hours.

If a power failure occurs, frozen foods will stay frozen for at least 24 hours if the freezer is kept closed. If the power failure continues, pack seven or eight pounds of dry ice into the freezer every 24 hours. Look in the Yellow Pages under Dry Ice, Dairies or Ice Cream Manufacturers for local dry ice suppliers. Always wear gloves and use caution when handling dry ice.

If the freezer has stopped operating, see "**FREEZER DOES NOT RUN**" in the "**TROUBLESHOOTING GUIDE**" section. If you cannot solve the problem, call Sears Service immediately.

If the freezer remains off for several hours, follow the directions above for the use of dry ice during a power failure. If necessary, take the food to a local locker plant until the freezer is ready to operate. Look in the Yellow Pages under Frozen Food Locker Plants.

ICE SERVICE

If your freezer has an automatic icemaker, it will provide a sufficient supply of ice for normal use. During the initial startup of your freezer, however, no ice will be produced during the first 24 hours of operation. Automatic ice makers are also optional accessories that may be installed in some models at any time. Call your local dealer for information.

TURNING YOUR ICE MAKER ON

After the plumbing connections have been completed, the water supply valve must be opened. Place the ice container under the ice maker, pushing it as far back as possible. Lower the wire signal arm to its "down" or ON position. New plumbing connections may cause the first production of ice cubes to be discolored or have an odd flavor. These first cubes should be discarded until the cubes produced are free of discoloration and taste.

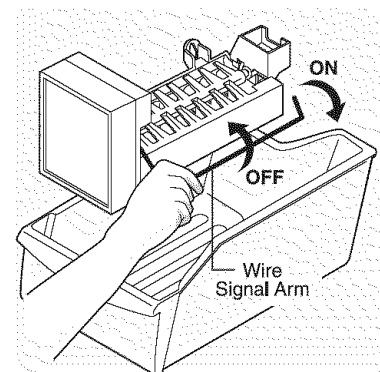

TURNING YOUR ICE MAKER OFF

To stop the ice maker, lift the wire signal arm until it clicks and locks in the "up" or OFF position. The ice maker also turns off automatically when the ice container is full. If your model has an adjustable freezer shelf, place the shelf in the lower position, so that the wire signal arm will hit the ice when the container is full.

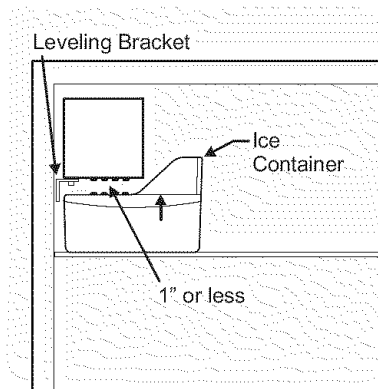

IMPORTANT

Your ice maker is shipped with the wire signal arm in the ON position. To ensure proper function of your ice maker, hook up water supply immediately or turn ice maker OFF by lifting the wire signal arm until it clicks and locks in the UP position.

Check the leveling bracket on the ice maker to ensure the ice maker is level. If the gap between the freezer wall and the ice maker is the same at top and bottom, then ice maker is level. If the ice maker is not level, loosen the screw and slide the bracket to the correct position to make it level. Retighten the screw. You will need a 1/4 inch socket wrench for this task.

ICE MAKER TIPS

- Ice cubes stored too long may develop an odd flavor. Empty the ice container and ensure that the wire signal arm is in its "down" or ON position. The ice maker will then produce more ice.
- Occasionally shake the ice container to keep ice separated.
- Keep the wire signal arm in its "up" or OFF position until the freezer is connected to the water supply or whenever the water supply is turned off.
- The following sounds are normal when the ice maker is operating:
 - Motor running
 - Ice loosening from tray
 - Ice dropping into ice container
 - Running water
 - Water valve opening or closing

CAUTION

- **DO NOT** place the ice container in your dishwasher
- Wash the ice container in warm water with mild detergent. Rinse well and dry.
- Stop the ice maker when cleaning the freezer and during vacations.
- If the ice maker will be turned off for a long period of time, turn the water supply valve to the closed position.

CARE AND CLEANING

Keep your freezer clean to prevent odor build-up. Wipe up any spills immediately and clean at least twice a year. Never use metallic scouring pads, brushes, abrasive cleaners or strong alkaline solutions on any surface. Do not wash any removable parts in a dishwasher. Always unplug the electrical power cord from the wall outlet before cleaning.

CAUTION

- When moving the freezer, pull straight out. Do not shift the freezer from side to side as this may tear or gouge the floor covering.
- Damp objects stick to cold metal surfaces. Do not touch interior metal surfaces with wet or damp hands.

NOTE

- Turning the freezer temperature control to "OFF" turns off the compressor, but does not disconnect electrical power to the light bulb or other electrical components. To turn off power to your freezer, you must unplug the power cord from the wall outlet.
- Do not use razor blades or other sharp instruments which can scratch the appliance surface when removing adhesive labels. Any glue left from tape or labels can be removed with a mixture of warm water and mild detergent, or, touch the glue residue with the sticky side of tape you have already removed. Do not remove the serial plate.

CARE AND CLEANING CHART

PART	WHAT TO USE	TIPS AND PRECAUTIONS
Interior/Door Liner	* Soap and water * Baking soda and water	Use 2 table spoons of baking soda in 1 quart of warm water. Be sure to wring excess water out of sponge or cloth before cleaning around controls, light bulb or any electrical part.
Door Gaskets	* Soap and water	Wipe gaskets with a clean soft cloth.
Drawers / Bins	* Soap and water	Do not wash any removable items (bins, drawers, etc.) in dishwasher.
Glass Shelves	* Soap and water * Glass cleaner * Mild liquid sprays	Allow glass to warm to room temperature before immersing in warm water.
Exterior and Handles	* Soap and water * Non Abrasive Glass Cleaner	Do not use commercial household cleaners, ammonia or alcohol to clean handles. Use a soft cloth to clean smooth handles. Do not use a dry cloth to clean smooth doors.
Exterior and Handles (Stainless Steel models only)	* Soap and water * Ammonia * Stainless Steel Cleaners	Clean stainless steel front and handles with soapy water and a dishcloth. Rinse with clean water and a soft cloth. Wipe stubborn spots with an ammonia-soaked paper towel, and rinse. Use a non-abrasive stainless steel cleaner. These cleaners can be purchased at most home improvement or major department stores. Always follow manufacturer's instructions. NOTE: Always clean, wipe and dry with the grain to prevent cross-grain scratching. Wash the rest of the cabinet with warm water and mild liquid detergent. Rinse well, and wipe dry with a clean soft cloth.

TROUBLESHOOTING GUIDE

TROUBLESHOOTING GUIDE	Before calling for service, review this list. It may save you time and expense. This list includes common occurrences that are not the result of defective workmanship or materials in this freezer.	
PROBLEM	CAUSE	CORRECTION
FREEZER OPERATION		
Freezer does not run.	* Freezer is plugged into a circuit that has a ground fault interrupt.	* Use another circuit. If you are unsure about the outlet, have it checked by a certified technician.
	* Temperature control is in the "OFF" position.	* See " SETTING THE TEMPERATURE CONTROL " section.
	* Freezer may not be plugged in, or plug may be loose.	* Ensure plug is tightly pushed into outlet.
	* House fuse blown or tripped circuit breaker.	* Check/replace fuse with a 15 amp time delay fuse. Reset circuit breaker.
	* Power outage.	* Check house lights. Call local Electric Company.
Freezer runs too much or too long.	* Room or outside weather is hot.	* It's normal for the freezer to work harder under these conditions.
	* Freezer has recently been disconnected for a period of time.	* It takes 24 hours for the freezer to cool down completely.
	* Large amount of warm or hot food have been stored recently.	* Warm food will cause freezer to run more until the desired temperature is reached.
	* Door is opened too frequently or kept open too long.	* Warm air entering the freezer causes it to run more. Open the door less often.
	* Freezer door may be slightly open.	* See " DOOR PROBLEMS ".
	* Temperature control is set too low.	* Turn control knob to a warmer setting. Allow several hours for the temperature to stabilize.
* Freezer gaskets are dirty, worn, cracked or poorly fitted.	* Clean or change gasket. Leaks in the door seal will cause freezer to run longer in order to maintain desired temperature.	
Interior freezer temperature is too cold.	* Temperature control is set too low.	* Turn control knob to a warmer setting. Allow several hours for the temperature to stabilize.
Interior freezer temperature is too warm.	* Temperature control is set too warm.	* Turn control knob to a colder setting. Allow several hours for the temperature to stabilize.
	* Door is opened too frequently or kept open too long.	* Warm air entering the freezer causes it to run more. Open the door less often.
	* Freezer door may be slightly open.	* See " DOOR PROBLEMS ".
	* Large amount of warm or hot food have been stored recently.	* Wait until the freezer has had a chance to reach its selected temperature.
* Freezer has recently been disconnected for a period of time.	* Freezer requires 24 hours to cool down completely.	
Freezer external surface temperature is warm.	* The external freezer walls can be as much as 30°F warmer than room temperature.	* This is normal while the compressor works to transfer heat from inside the freezer cabinet.
SOUND AND NOISE		
Louder sound levels whenever freezer is on.	* Modern freezers have increased storage capacity and more stable temperatures. They require heavy duty compressors.	* This is normal. When the surrounding noise level is low, you might hear the compressor running while it cools the interior.
Louder sound levels when compressor comes on.	* Freezer operates at higher pressures during the start of the ON cycle.	* This is normal. Sound will level off or disappear as freezer continues to run.
Popping or cracking sound when compressor comes on.	* Metal parts undergo expansion and contraction, as in hot water pipes.	* This is normal. Sound will level off or disappear as freezer continues to run.

TROUBLESHOOTING GUIDE

PROBLEM	CAUSE	CORRECTION
SOUND AND NOISE (Cont.)		
Bubbling or gurgling sound,	* Refrigerant (used to cool freezer is circulating throughout the system.	* This is normal.
Vibrating or rattling noise.	* Freezer is not level. It rocks on the floor when it is moved slightly.	* Level the freezer. Refer to " LEVELING " in the " FIRST STEPS " section.
	* Floor is uneven or weak.	* Ensure floor can adequately support freezer. Level the freezer by putting wood or metal shims under part of the freezer.
	* Freezer is touching the wall.	* Re-level freezer or move freezer slightly. Refer to " LEVELING " in the " FIRST STEPS " section.
WATER / MOISTURE / FROST INSIDE FREEZER		
Moisture forms on inside freezer walls.	* Weather is hot and humid, which increases internal rate of frost build-up.	* This is normal.
	* Door is slightly open.	* See " DOOR PROBLEMS ".
	* Door is kept open too long or is opened too frequently.	* Open the door less often.
WATER / MOISTURE / FROST OUTSIDE FREEZER		
Moisture forms on outside freezer walls.	* Door may not be seating properly, causing the cold air from inside the freezer to meet warm moist air from outside.	* See " DOOR PROBLEMS ".
ODOR IN FREEZER		
Odors in freezer.	* Interior needs to be cleaned.	* Clean interior with sponge, warm water, and baking soda. Replace air filter.
	* Foods with strong odors are in the freezer.	* Cover the food tightly.
DOOR PROBLEMS		
Door will not close.	* Freezer is not level. It rocks on the floor when it is moved slightly.	* This condition can force the cabinet out of square and misalign the door. Refer to " LEVELING " in the " FIRST STEPS " section.
	* Floor is uneven or weak.	* Ensure floor can adequately support freezer. Level the freezer by putting wood or metal shims under part of the freezer.
LIGHTING PROBLEMS		
Light bulb is not on.	* The fluorescent lamp or light bulb is burned out.	* Follow directions under " INTERIOR LIGHTING " or " MID LEVEL LIGHTING " in the " FREEZER FEATURES " section.
	* No electric current is reaching the freezer.	* See " FREEZER DOES NOT RUN ".
AUTOMATIC ICE MAKER		
Automatic ice maker not working.	* Ice maker is not working.	* Ensure the wire signal arm is not in the UP position
		* Water supply is turned off.
		* Water pressure is too low.
		* The freezer is not cold enough.

SEARS SERVICE

"We Service What We Sell" is our assurance you can depend on Sears for service ... and Sears service is nationwide. Your freezer has added value when you consider that Sears has service units nationwide, staffed with professional technicians specifically trained on Sears appliances and having parts, tools and equipment to ensure that we meet our pledge to you... "We Service What We Sell".

SEARS MAINTENANCE AGREEMENT

Maintain the value of your Kenmore PRO® freezer with a Sears Maintenance Agreement. Sears freezers are designed, manufactured and tested for years of dependable operation. Yet, any modern appliance may require service from time to time.

The Sears Maintenance Agreement

- Is your way to buy tomorrow's service at today's price.
- Eliminates repair bills resulting from normal use.
- Allows for as many service calls as required.
- Provides for service by professional Sears-trained technicians.
- Offers an annual preventive maintenance check-up at your request.

This maintenance agreement does not cover original installation, reinstallation, or damage resulting from external causes such as acts of God, abuse, theft, fire, flood, wind, lightning, freezing, power failure, power reduction, etc. Please ask a salesperson to see the agreement for all of the terms and conditions.

SEARS CANADA CUSTOMERS

Dear Customer:

In manufacturing this product, many steps have been taken to provide you with the highest quality. Unfortunately, errors or omissions occasionally occur. In the event you find a missing or defective part, please contact your nearest Sears store. (See the back cover for phone numbers).

If you have any suggestions that would help us to improve our assembly/operation instructions or this product, please write them down, including the information listed below and mail to:

Sears Canada, Inc. Attn: Buyer Dept. 646
222 Jarvis Street
Toronto, Ontario
M5B 2B8

Purchased by:

Name: _____

Address: _____

City: _____ Prov.: _____

Postal Code: _____ Phone: _____

Model No.: 970 _____

Serial No.: _____

Date of Purchase: _____

Location of Purchase: _____

Comments: _____

ENGLISH