

SEARS

CRAFTSMAN[®]

MODEL NUMBER 917.252711

OWNER'S MANUAL

- Assembly
- Operation
- Customer Responsibilities
- Service and Adjustments
- Repair Parts

3one[®]
Convertible

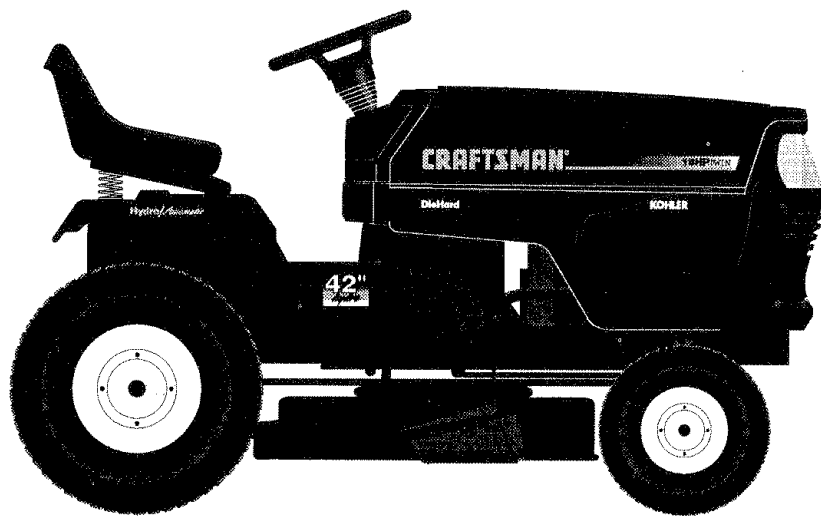

CAUTION: Read and follow all safety rules and instructions before operating this equipment.
FOR CONSUMER ASSISTANCE HOT LINE, CALL THIS TOLL FREE NUMBER: 1-800-659-5917

Sears, Roebuck and Co., Hoffman Estates, IL 60179 U.S.A.



SAFETY RULES



Safe Operation Practices for Ride-On Mowers

IMPORTANT: THIS CUTTING MACHINE IS CAPABLE OF AMPUTATING HANDS AND FEET AND THROWING OBJECTS. FAILURE TO OBSERVE THE FOLLOWING SAFETY INSTRUCTIONS COULD RESULT IN SERIOUS INJURY OR DEATH.

I. GENERAL OPERATION

- Read, understand, and follow all instructions in the manual and on the machine before starting.
- Only allow responsible adults, who are familiar with the instructions, to operate the machine.
- Clear the area of objects such as rocks, toys, wire, etc., which could be picked up and thrown by the blade.
- Be sure the area is clear of other people before mowing. Stop machine if anyone enters the area.
- Never carry passengers.
- Do not mow in reverse unless absolutely necessary. Always look down and behind before and while backing.
- Be aware of the mower discharge direction and do not point it at anyone. Do not operate the mower without either the entire grass catcher or the guard in place.
- Slow down before turning.
- Never leave a running machine unattended. Always turn off blades, set parking brake, stop engine, and remove keys before dismounting.
- Turn off blades when not mowing.
- Stop engine before removing grass catcher or unclogging chute.
- Mow only in daylight or good artificial light.
- Do not operate the machine while under the influence of alcohol or drugs.
- Watch for traffic when operating near or crossing roadways.
- Use extra care when loading or unloading the machine into a trailer or truck.

II. SLOPE OPERATION

Slopes are a major factor related to loss-of-control and tipover accidents, which can result in severe injury or death. All slopes require extra caution. If you cannot back up the slope or if you feel uneasy on it, do not mow it.

DO:

- Mow up and down slopes, not across.
- Remove obstacles such as rocks, tree limbs, etc.
- Watch for holes, ruts, or bumps. Uneven terrain could overturn the machine. *Tall grass can hide obstacles.*
- Use slow speed. Choose a low gear so that you will not have to stop or shift while on the slope.
- Follow the manufacturer's recommendations for wheel weights or counterweights to improve stability.
- Use extra care with grass catchers or other attachments. These can change the stability of the machine.
- Keep all movement on the slopes *slow* and *gradual*. Do not make sudden changes in speed or direction.
- Avoid starting or stopping on a slope. If tires lose traction, disengage the blades and proceed slowly *straight* down the slope.

DO NOT:

- *Do not* turn on slopes unless necessary, and then, turn slowly and gradually downhill, if possible.
- *Do not* mow near drop-offs, ditches, or embankments. The mower could suddenly turn over if a wheel is over the edge of a cliff or ditch, or if an edge caves in.
- *Do not* mow on wet grass. Reduced traction could cause sliding.
- *Do not* try to stabilize the machine by putting your foot on the ground.
- *Do not* use grass catcher on steep slopes.

III. CHILDREN

Tragic accidents can occur if the operator is not alert to the presence of children. Children are often attracted to the machine and the mowing activity. *Never* assume that children will remain where you last saw them.

- Keep children out of the mowing area and under the watchful care of another responsible adult.
- Be alert and turn machine off if children enter the area.
- Before and when backing, look behind and *down* for small children.
- Never carry children. They may fall off and be seriously injured or interfere with safe machine operation.
- Never allow children to operate the machine.
- Use extra care when approaching blind corners, shrubs, trees, or other objects that may obscure vision.

IV. SERVICE

- Use extra care in handling gasoline and other fuels. They are flammable and vapors are explosive.
 - Use only an approved container.
 - Never remove gas cap or add fuel with the engine running. Allow engine to cool before refueling. Do not smoke.
 - Never refuel the machine indoors.
 - Never store the machine or fuel container inside where there is an open flame, such as a water heater.
- Never run a machine inside a closed area.
- Keep nuts and bolts, especially blade attachment bolts, tight and keep equipment in good condition.
- Never tamper with safety devices. Check their proper operation regularly.
- Keep machine free of grass, leaves, or other debris build-up. Clean oil or fuel spillage. Allow machine to cool before storing.
- Stop and inspect the equipment if you strike an object. Repair, if necessary, before restarting.
- Never make adjustments or repairs with the engine running.
- Grass catcher components are subject to wear, damage, and deterioration, which could expose moving parts or allow objects to be thrown. Frequently check components and replace with manufacturer's recommended parts, when necessary.
- Mower blades are sharp and can cut. Wrap the blade(s) or wear gloves, and use extra caution when servicing them.
- Check brake operation frequently. Adjust and service as required.



Look for this symbol to point out important safety precautions. It means CAUTION!!! BECOME ALERT!!! YOUR SAFETY IS INVOLVED.



CAUTION: Always disconnect spark plug wire and place wire where it cannot contact spark plug in order to prevent accidental starting when setting up, transporting, adjusting or making repairs.



WARNING

The engine exhaust from this product contains chemicals known to the State of California to cause cancer, birth defects, or other reproductive harm.

CONGRATULATIONS on your purchase of a Sears tractor. It has been designed, engineered and manufactured to give you the best possible dependability and performance.

Should you experience any problem you cannot easily remedy, please contact your nearest Sears Service Center/Department. We have competent, well-trained technicians and the proper tools to service or repair this tractor.

Please read and retain this manual. The instructions will enable you to assemble and maintain your tractor properly. Always observe the "SAFETY RULES".

MODEL NUMBER 917.252711

SERIAL NUMBER _____

DATE OF PURCHASE _____

THE MODEL AND SERIAL NUMBERS WILL BE FOUND ON A PLATE UNDER THE SEAT.

YOU SHOULD RECORD BOTH SERIAL NUMBER AND DATE OF PURCHASE AND KEEP IN A SAFE PLACE FOR FUTURE REFERENCE.

MAINTENANCE AGREEMENT

A Sears maintenance agreement is available on this product. Contact your nearest Sears store for details.

CUSTOMER RESPONSIBILITIES

- Read and observe the safety rules.
- Follow a regular schedule in maintaining, caring for and using your tractor.
- Follow the instructions under "Customer Responsibilities" and "Storage" sections of this owner's manual.

PRODUCT SPECIFICATIONS

HORSEPOWER:	18.0
GASOLINE CAPACITY AND TYPE:	3.5 GALLONS UNLEADED REGULAR
OIL TYPE (API-SF/SG):	SAE 30 (above 32°F) SAE 5W-30 (below 32°F)
OIL CAPACITY:	W/ FILTER: 4.0 PINTS W/O FILTER: 3.5 PINTS
SPARK PLUG: (GAP: .025")	CHAMPION RV17YC
VALVE CLEARANCE:	INTAKE: .003" - .006" EXHAUST: .013" - .016"
GROUND SPEED (MPH):	FORWARD: 5.6 REVERSE: 2.5
TIRE PRESSURE:	FRONT: 14 PSI REAR: 10 PSI
CHARGING SYSTEM:	15 AMPS @3600RPM
BLADE BOLT TORQUE:	30-35 FT. LBS.

WARNING: This tractor is equipped with an internal combustion engine and should not be used on or near any unimproved forest-covered, brush-covered or grass-covered land unless the engine's exhaust system is equipped with a spark arrester meeting applicable local or state laws (if any). If a spark arrester is used, it should be maintained in effective working order by the operator.

In the state of California the above is required by law (Section 4442 of the California Public Resources Code). Other states may have similar laws. Federal laws apply on federal lands. A spark arrester for the muffler is available through your nearest Sears Authorized Service Center (See REPAIR PARTS section of this manual).

LIMITED TWO YEAR WARRANTY ON CRAFTSMAN RIDING EQUIPMENT

For two (2) years from the date of purchase, if this Craftsman Riding Equipment is maintained, lubricated and tuned up according to the instructions in the owner's manual, Sears will repair or replace, free of charge, any parts found to be defective in material or workmanship.

This Warranty does not cover:

- Expendable items which become worn during normal use, such as blades, spark plugs, air cleaners, belts, etc.
- Tire replacement or repair caused by punctures from outside objects, such as nails, thorns, stumps, or glass.
- Repairs necessary because of operator abuse, negligence, improper storage or accident or the failure to maintain the equipment according to the instructions contained in the owner's manual.
- Riding equipment used for commercial or rental purposes.

LIMITED 90 DAY WARRANTY ON BATTERY

For ninety (90) days from date of purchase, if any battery included with this riding equipment proves defective in material or workmanship and our testing determines the battery will not hold a charge, Sears will replace the battery at no charge.







IN-HOME WARRANTY SERVICE ON YOUR CRAFTSMAN RIDING EQUIPMENT IS AVAILABLE AT NO-CHARGE FOR 30 DAYS FROM THE DATE OF PURCHASE. PLEASE CONTACT YOUR NEAREST SERVICE CENTER. AFTER 30 DAYS FROM THE DATE OF PURCHASE, WARRANTY SERVICE IS AVAILABLE BY TAKING YOUR CRAFTSMAN RIDING EQUIPMENT TO YOUR NEAREST SEARS SERVICE CENTER. (IN-HOME WARRANTY SERVICE WILL STILL BE AVAILABLE AFTER 30 DAYS FROM THE DATE OF PURCHASE BUT A STANDARD TRIP CHARGE WILL APPLY.) THIS WARRANTY APPLIES ONLY WHILE THIS PRODUCT IS IN THE UNITED STATES.

This Warranty gives you specific legal rights, and you may also have other rights which may vary from state to state.

SEARS, ROEBUCK AND CO., D/817 WA, HOFFMAN ESTATES, IL 60179

ACCESSORIES AND ATTACHMENTS

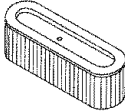
These accessories and attachments were available through most Sears retail outlets and service centers when the tractor was purchased. Most Sears stores can order these items for you when you provide the model number of your tractor.

ENGINE					MAINTENANCE	
SPARK PLUG	GAS CAN	ENGINE OIL	FUEL STABILIZER	AIR FILTER	BLADES	BELTS
						

PERFORMANCE

Sears offers a wide variety of attachments that fit your tractor. Many of these are listed below with brief explanations of how they can help you. This list was current at the time of publication; however, it may change in future years - more attachments may be added, changes may be made in these attachments, or some may no longer be available or fit your model. **Contact your nearest Sears store for the accessories and attachments that are available for your tractor.**

Most of these attachments do not require additional hitches or conversion kits (those that do are indicated) and are designed for easy attaching and detaching.

AERATOR promotes deep root growth for a healthy lawn. Tapered 2.5-inch steel spikes mounted on 10-inch diameter discs puncture holes in soil at close intervals to let moisture soak in. Steel weight tray for increased penetration.

BAGGER lets you collect grass clippings and leaves for a healthier, neater looking lawn. Two Permanex containers hold 30-gallon plastic bags.

BUMPER protects front end of tractor from damage.

CARTS make hauling easy. Variety of sizes available, plus accessories such as side panel kits, tool caddy, cart cover, protective mat and dolly.

CORING AERATOR takes small plugs out of soil to allow moisture and nutrients to reach grass roots. 36-inch swath. 24 hardened steel coring tips. 150 lb. capacity weight tray.

EASY OIL DRAIN VALVE makes oil changes easier, faster.

FRONT NOSE ROLLER canters in front of mower deck to reduce chances of "scalping" on uneven terrain.

GANG HITCH lets you tow 2 or 3 pull-behind attachments at once, such as sweepers, dethatchers, aerators (not for use with rollers, carts or other heavy attachments).

GAUGE WHEELS on both sides of the mower deck reduce chances of "scalping" on uneven terrain. For mower decks not so equipped.

MULCH RAKE/DETHATCHER loosens soil and flips thatch and matted leaves to lawn surface for easy pickup. Twenty spring tine teeth. Useful to prepare bare areas for seeding. Available for front or rear mounting. **HIGH PERFORMANCE REEL-ACTION SPRING TINE DETHATCHER** covers 36-inch wide path and tosses thatch into large hopper. Mounts behind tractor.

MULCHING CLOSE-OUT PLATE KIT, once installed, lets you mulch, discharge or bag clippings (bagger optional) without changing blades. For models not equipped as 3-in-1 Convertible mowers. See "MOWER" in the Repair Parts section of this manual.

RAMP TOPS AND FEET let you load and unload tractor from a pickup truck. Use with 2 x 8 or 2 x 10 lumber.

ROLLER for smoother lawn surface. 36-inch wide, 18-inch diameter water-tight drum holds up to 390 lbs. of weight. Rounded edges prevent harm to turf. Adjustable scraper automatically cleans drum.

SNOW BLADE for snow removal only. 14-inch high, 48-inch wide blade clears 42-inch path when angled left or right. Raises, lowers with side lever. Adjustable skids; replaceable, reversible scraper bar. (Use with tire chains and wheel weights and/or rear drawbar weight.)

SNOWTHROWER has 40-inch swath. Drum-type auger handles powdery and wet/heavy snow. Mounts easily with simple pin arrangement. Discharge chute adjusts from tractor seat. 6-inch diameter spout discharges snow 10 to 50 feet. Lift controlled at tractor seat. (Use with chains and wheel weights and/or rear drawbar weight.)

SPRAYERS use 12-volt DC electric motor that connects to the tractor battery or other 12-volt source. Includes booms for automatic spraying and hand held wand for spot spraying. Wand has adjustable spray pattern. For applying herbicides, insecticides, fungicides and liquid fertilizers.

SPREADER/SEEDERS make seeding, fertilizing, and weed killing easy. Broadcast spreaders are also useful for granular deicers and sand.

SWEEPERS let you collect grass clippings and leaves.

TILLER has 5 hp engine and 36-inch swath to prepare seed beds, cultivate and compost garden residue. Tiller has its own built-in lift and depth control system and does NOT require a sleeve hitch. Fits any lawn, yard or garden tractor. Simply hook up to the tractor drawbar and go! **Optional accessories** convert unit for dethatching, aerating, hilling...without tools.

TIRE CHAINS are heavy duty; closely spaced extra-large cross links give smooth ride, outstanding traction.

TRACTOR CAB has heavy duty vinyl fabric over tubular steel frame, ABS plastic top; clear plastic windshield offers 360 degree visibility. Hinged metal doors with catch. Keeps operator warm and dry. Remove vinyl sides and windshields for use as sun protector in summer. **Optional accessories include:** tinted/tempered solid safety glass windshield with hand operated wiper; 12-volt amber caution light for mounting on cab top.

VACS for powerful collection of heavy grass clippings and leaves. **Optional wand attachment** to pick up debris in hard-to-reach places. **VAC/CHIPPER** includes a chipper-shredder.

WEIGHT BRACKET for drawbar for snow removal applications. Uses (1) 55 lb. weight.

WHEEL WEIGHTS for rear wheels provide needed traction for snow removal or dozing heavy materials.

CONTENTS OF HARDWARE PACK

Parts Bag contents shown full size

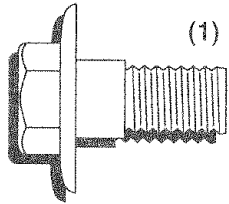

(1) Shoulder Bolt
5/16-18

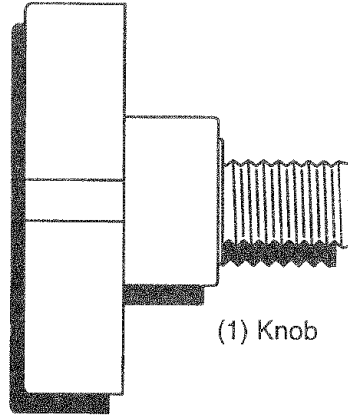

(1) Knob

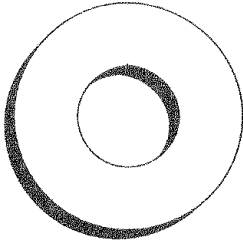

(1) Washer
17/32 x 1-3/16 x 12 Gauge

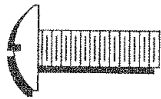

(2) Screws #10 x 5/8



(2) Lock Washers #10

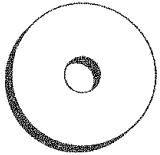

(2) Washers
3/16 x 3/4 x 16 Gauge

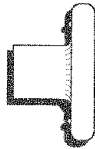

(2) Weld Nuts #10



(2) Hex Bolts 1/4-20 x 3/4



(2) Hex Nuts 1/4-20



(2) Washers
9/32 x 5/8 x 16 Ga.



(2) Lock Washers 1/4

Parts packed separately in carton

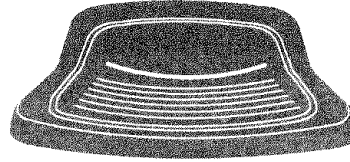

Seat

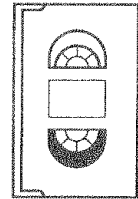

Video
Cassette

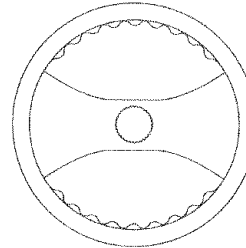

Steering
Wheel

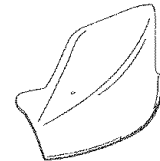

Mulcher
Plate



Manual



Parts Bag

Parts bag contents not shown full size



(2) Shoulder
Bolts



(2) Washers 3/8
x 7/8 x 14 Gauge

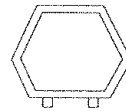

Steering
Wheel
Insert



(2) Center-
lock Nuts

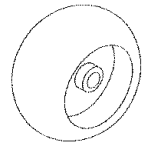

(2) Gauge
Wheels



(2) Keys

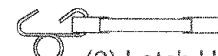

(2) Latch Hook
Assembly

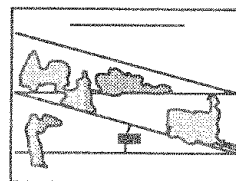

Slope Sheet



Steering
Sleeve

ASSEMBLY

Your new tractor has been assembled at the factory with exception of those parts left unassembled for shipping purposes. To ensure safe and proper operation of your tractor, all parts and hardware you assemble must be tightened securely. Use the correct tools as necessary to insure proper tightness.

TOOLS REQUIRED FOR ASSEMBLY

A socket wrench set will make assembly easier. Standard wrench sizes are listed.

- | | |
|---------------------|---------------------------------|
| (1) 9/16" wrench | (2) 7/16" wrench |
| (1) 1/2" wrench | (1) 3/4" socket w/drive ratchet |
| Utility knife | |
| Tire pressure gauge | (1) Phillips Screwdriver |

When right and left hand is mentioned in this manual, it means when you are in the operating position (seated behind the steering wheel).

TO REMOVE TRACTOR FROM CARTON

UNPACK CARTON

- Remove all accessible loose parts and parts cartons from carton (See page 6).
- Cut, from top to bottom, along lines on all four corners of carton, and lay panels flat.
- Check for any additional loose parts or cartons and remove.

BEFORE ROLLING TRACTOR OFF SKID

ATTACH STEERING WHEEL (See Fig. 1)

- Remove locknut and large flat washer from steering shaft.
- Position front wheels of the tractor so they are pointing straight forward.
- Slide the steering sleeve over the steering shaft.
- Position steering wheel so cross bars are horizontal (left to right) and slide onto adapter.
- Secure steering wheel to steering shaft with locknut and large flat washer previously removed. Tighten securely.
- Snap steering wheel insert into center of steering wheel.
- Remove protective plastic from tractor hood and grill.

IMPORTANT: CHECK FOR AND REMOVE ANY STAPLES IN SKID THAT MAY PUNCTURE TIRES WHERE TRACTOR IS TO ROLL OFF SKID.

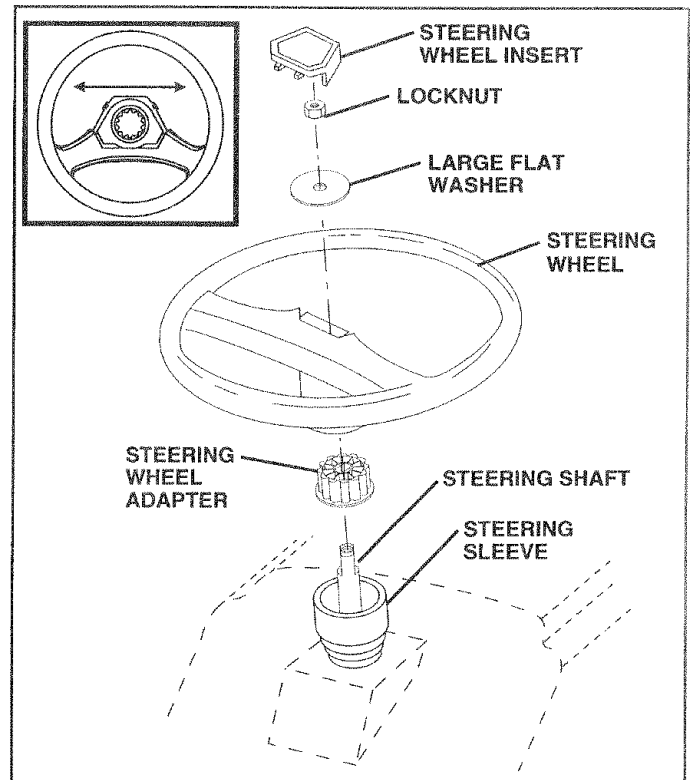

FIG. 1

TO ROLL TRACTOR OFF SKID (See Fig. 7)

- Raise attachment lift lever to its highest position.
- Release parking brake by depressing clutch/brake pedal.
- Place freewheel control in freewheeling position to disengage transmission (See "TO TRANSPORT" in Operation section of this manual).
- Roll tractor backwards off skid.
- Remove banding holding discharge guard up against tractor.

ASSEMBLY

CONNECT BATTERY (See Fig. 2)



CAUTION: Do not short battery terminals. Before connecting battery, remove metal bracelets, wristwatch bands, rings, etc.

Positive terminal must be connected first to prevent sparking from accidental grounding.

- Lift hood to raised position.
- Open terminal access doors, remove terminal protective caps and discard.
- If this battery is put into service after month and year indicated on label (label located between terminals) charge battery for minimum of one hour at 6-10 amps.
- First connect RED battery cable to positive (+) battery terminal with hex bolt, flat washer, lock washer and hex nut as shown. Tighten securely.
- Connect BLACK grounding cable to negative (-) battery terminal with remaining hex bolt, flat washer, lock washer and hex nut. Tighten securely.
- Close terminal access doors.

Use terminal access doors for:

- Inspection for secure connections (to tighten hardware).
- Inspection for corrosion.
- Testing battery.
- Jumping (if required).
- Periodic charging.

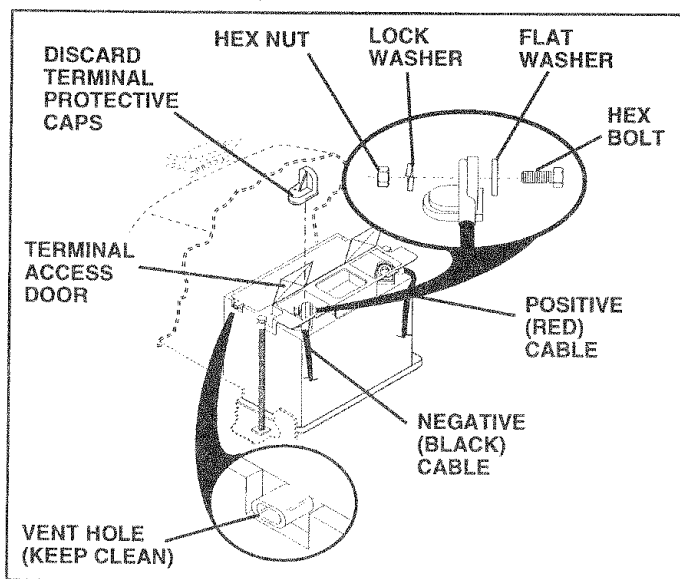

FIG. 2

INSTALL SEAT (See Fig. 3)

Adjust seat before tightening adjustment knob.

- Remove cardboard packing on seat pan.
- Place seat on seat pan and assemble shoulder bolt.
- Assemble adjustment knob and flat washer loosely. Do not tighten.
- Tighten shoulder bolt securely.
- Lower seat into operating position and sit on seat.
- Slide seat until a comfortable position is reached which allows you to press clutch/brake pedal all the way down.
- Get off seat without moving its adjusted position.
- Raise seat and tighten adjustment knob securely.

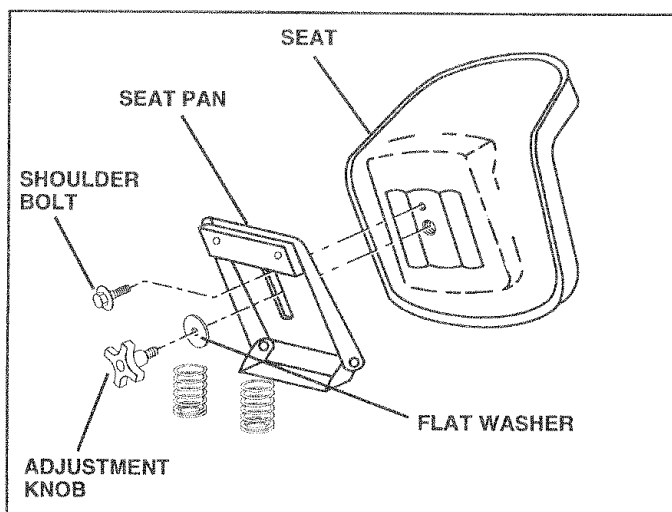

FIG. 3

ASSEMBLY

CHECK TIRE PRESSURE

The tires on your tractor were overinflated at the factory for shipping purposes. Correct tire pressure is important for best cutting performance.

- Reduce tire pressure to PSI shown in "PRODUCT SPECIFICATIONS" on page 3 of this manual.

CHECK DECK LEVELNESS

For best cutting results, mower housing should be properly leveled. See "TO LEVEL MOWER HOUSING" in the Service and Adjustments section of this manual.

CHECK FOR PROPER POSITION OF ALL BELTS

See the figures that are shown for replacing motion and mower blade drive belts in the Service and Adjustments section of this manual. Verify that the belts are routed correctly.

CHECK BRAKE SYSTEM

After you learn how to operate your tractor, check to see that the brake is properly adjusted. See "TO ADJUST BRAKE" in the Service and Adjustments section of this manual.

ASSEMBLE GAUGE WHEELS TO MOWER DECK (See Fig. 4)

Assemble gauge wheels with tractor on a flat level surface.

- Adjust mower to desired cutting height (See "TO ADJUST MOWER CUTTING HEIGHT" in the Operation section of this manual).
- With mower in desired height of cut position, gauge wheels should be assembled so they are slightly off the ground. Install gauge wheel in appropriate hole with shoulder bolt, 3/8 washer, and 3/8-16 locknut and tighten securely.
- Repeat for opposite side installing gauge wheel in same adjustment hole.

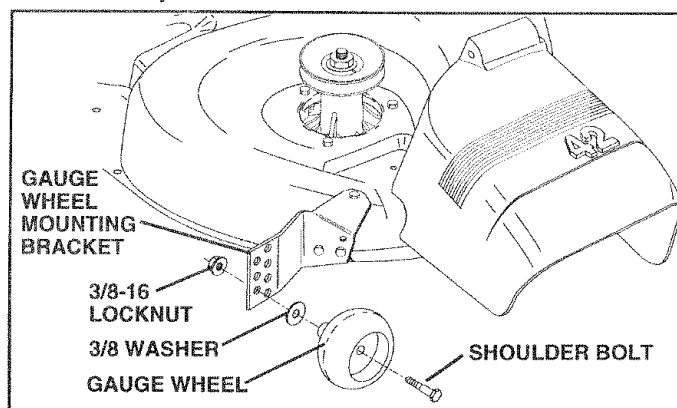

FIG. 4

ASSEMBLY

INSTALL MULCHER PLATE

(See Figs. 5 and 6)

- Install two latch hooks to mulcher plate using screw, washer, lock washer, and weld nut as shown.

NOTE: Pre-assemble weld nut to latch hook by inserting weld nut from the top with hook pointing down.

- Tighten hardware securely.
- Raise and hold deflector shield in upright position.
- Place front of mulcher plate over front of mower deck opening and slide into place, as shown.
- Hook front latch into hole on front of mower deck.
- Hook rear latch into hole on back of mower deck.



CAUTION: Do not remove discharge guard from mower. Raise and hold guard when attaching mulcher plate and allow it to rest on plate while in operation.

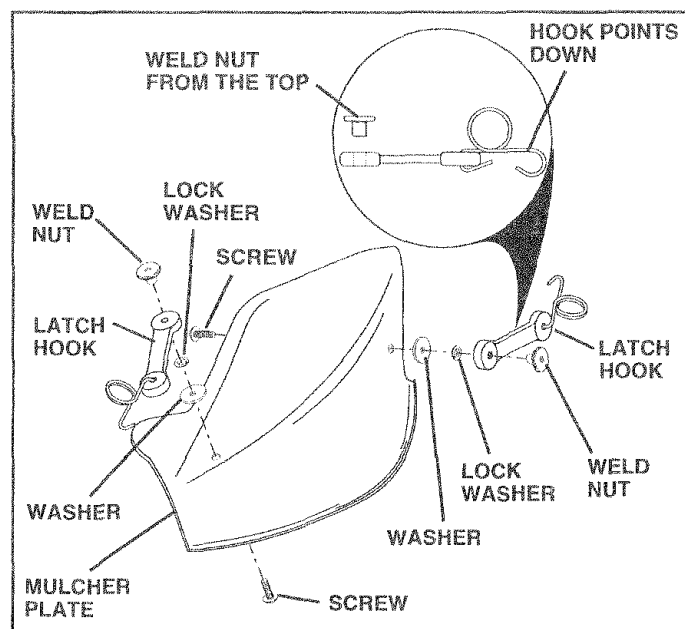

FIG. 5

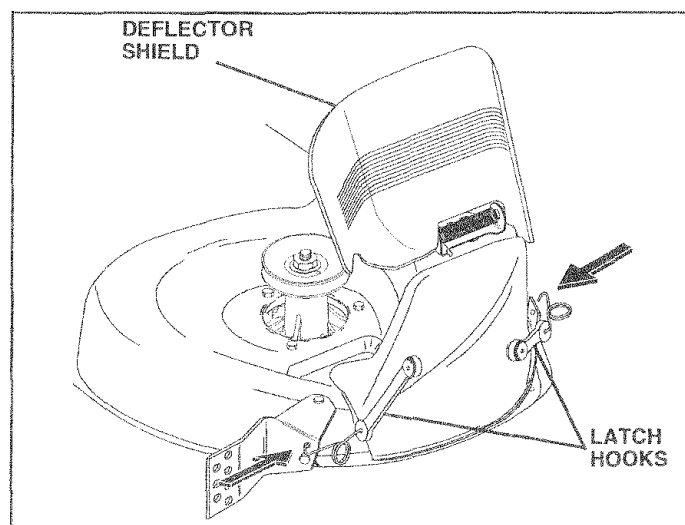

FIG. 6

TO CONVERT TO BAGGING OR DISCHARGING

Simply remove mulcher plate and store in a safe place. Your mower is now ready for discharging or installation of optional grass catcher accessory.

✓ CHECKLIST

BEFORE YOU OPERATE AND ENJOY YOUR NEW TRACTOR, WE WISH TO ASSURE THAT YOU RECEIVE THE BEST PERFORMANCE AND SATISFACTION FROM THIS QUALITY PRODUCT.

PLEASE REVIEW THE FOLLOWING CHECKLIST:

- ✓ All assembly instructions have been completed.
- ✓ No remaining loose parts in carton.
- ✓ Battery is properly prepared and charged. (Minimum 1 hour at 6 amps).
- ✓ Seat is adjusted comfortably and tightened securely.
- ✓ All tires are properly inflated. (For shipping purposes, the tires were overinflated at the factory).
- ✓ Be sure mower deck is properly leveled side-to-side/front-to-rear for best cutting results. (Tires must be properly inflated for leveling).
- ✓ Check mower and drive belts. Be sure they are routed properly around pulleys and inside all belt keepers.
- ✓ Check wiring. See that all connections are still secure and wires are properly clamped.
- ✓ Before driving tractor, be sure freewheel control is in drive position.

WHILE LEARNING HOW TO USE YOUR TRACTOR, PAY EXTRA ATTENTION TO THE FOLLOWING IMPORTANT ITEMS:

- ✓ Engine oil is at proper level.
- ✓ Fuel tank is filled with fresh, clean, regular unleaded gasoline.
- ✓ Become familiar with all controls - their location and function. Operate them before you start the engine.
- ✓ Be sure brake system is in safe operating condition.
- ✓ It is important to purge the transmission before you operate your new tractor for the first time. Follow proper starting and transmission purging instructions (See "TO START ENGINE" and "PURGE TRANSMISSION" in Operation section of this manual).

OPERATION

These symbols may appear on your tractor or in literature supplied with the product. Learn and understand their meaning.

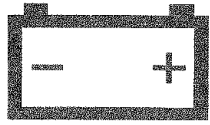

BATTERY

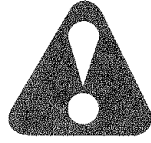

CAUTION OR WARNING



REVERSE



FORWARD

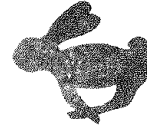

FAST



SLOW



ENGINE ON



ENGINE OFF

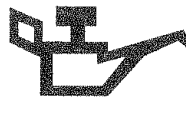

OIL PRESSURE



CLUTCH



LIGHTS ON



LIGHTS OFF



FUEL



CHOKE



MOWER HEIGHT

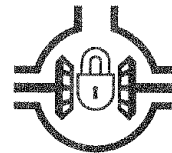

DIFFERENTIAL LOCK



PARKING BRAKE LOCKED



UNLOCKED

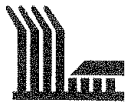

MOWER LIFT



REVERSE



NEUTRAL



HIGH



LOW



PARKING BRAKE



ATTACHMENT CLUTCH ENGAGED



ATTACHMENT CLUTCH DISENGAGED



IGNITION



DANGER, KEEP HANDS AND FEET AWAY

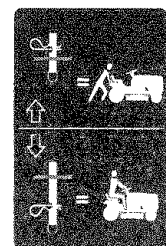
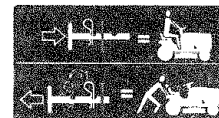

HYDROSTATIC FREE WHEEL
(Hydro Models only)

OPERATION

KNOW YOUR TRACTOR

READ THIS OWNER'S MANUAL AND SAFETY RULES BEFORE OPERATING YOUR TRACTOR

Compare the illustrations with your tractor to familiarize yourself with the locations of various controls and adjustments. Save this manual for future reference.

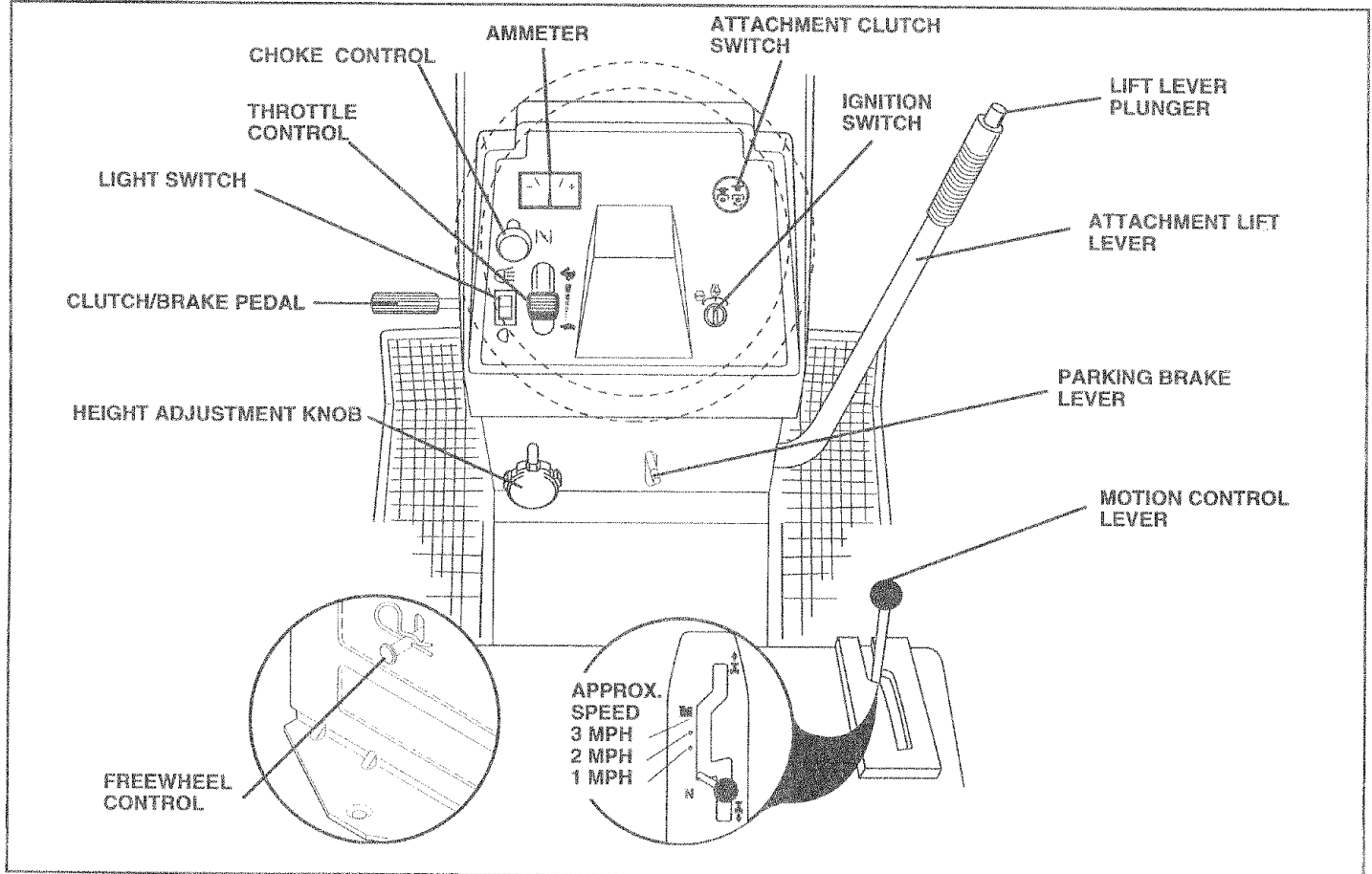

FIG. 7

Our tractors conform to the safety standards of the American National Standards Institute.

ATTACHMENT CLUTCH SWITCH: Used to engage the mower blades, or other attachments mounted to your tractor.

LIGHT SWITCH: Turns the headlights on and off.

THROTTLE CONTROL: Used to control engine speed.

CHOKE CONTROL: Used when starting a cold engine.

CLUTCH/BRAKE PEDAL: Used for declutching and braking the tractor and starting the engine.

PARKING BRAKE LEVER: Locks clutch/brake pedal into the brake position.

AMMETER: Indicates charging (+) or discharging (-) of battery.

HEIGHT ADJUSTMENT KNOB: Used to release attachment lift lever when changing its position.

MOTION CONTROL LEVER: Selects the speed and direction of tractor.

LIFT LEVER PLUNGER: Used to release attachment lift lever when changing its position.

ATTACHMENT LIFT LEVER: Used to raise and lower the mower deck or other attachments mounted to your tractor.

IGNITION SWITCH: Used for starting and stopping the engine.

FREEWHEEL CONTROL: Disengages transmission for pushing or slowly towing the tractor with the engine off.

OPERATION



The operation of any tractor can result in foreign objects thrown into the eyes, which can result in severe eye damage. Always wear safety glasses or eye shields while operating your tractor or performing any adjustments or repairs. We recommend a wide vision safety mask over the spectacles or standard safety glasses.

HOW TO USE YOUR TRACTOR TO SET PARKING BRAKE (See Fig. 8)

Your tractor is equipped with an operator presence sensing switch. When engine is running, any attempt by the operator to leave the seat without first setting the parking brake will shut off the engine.

- Depress clutch/brake pedal into full "BRAKE" position and hold.
- Place parking brake lever in "ENGAGED" position and release pressure from clutch/brake pedal. Pedal should remain in "BRAKE" position. Make sure parking brake will hold vehicle secure.

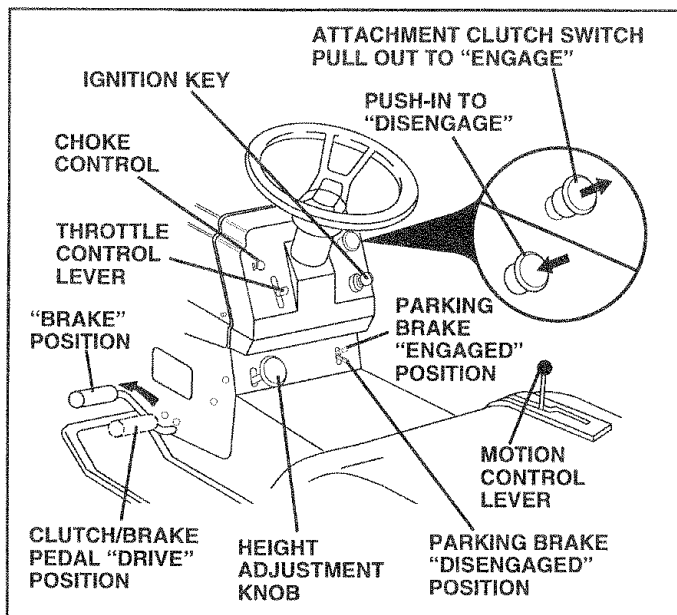

FIG. 8

STOPPING (See Fig. 8)

MOWER BLADES -

- Move attachment clutch switch to "DISENGAGED" position.

GROUND DRIVE -

- Depress clutch/brake pedal into full "BRAKE" position.
- Move motion control lever to neutral (N) position.

IMPORTANT: THE MOTION CONTROL LEVER DOES NOT RETURN TO NEUTRAL (N) POSITION WHEN THE CLUTCH/BRAKE PEDAL IS DEPRESSED.

ENGINE -

- Move throttle control to slow (🐢) position.

NOTE: Failure to move throttle control to slow (🐢) position and allowing engine to idle before stopping may cause engine to "backfire".

- Turn ignition key to "OFF" position and remove key. Always remove key when leaving tractor to prevent unauthorized use.
- Never use choke to stop engine.

NOTE: Under certain conditions when tractor is standing idle with the engine running, hot engine exhaust gases may cause "browning" of grass. To eliminate this possibility, always stop engine when stopping tractor on grass areas.



CAUTION: Always stop tractor completely, as described above, before leaving the operator's position; to empty grass catcher, etc.

TO USE THROTTLE CONTROL (See Fig. 8)

Always operate engine at full throttle.

- Operating engine at less than full throttle reduces the battery charging rate.
- Full throttle offers the best bagging and mower performance.

TO USE CHOKER CONTROL (See Fig. 8)

Use choke control whenever you are starting a cold engine. Do not use to start a warm engine.

- To engage choke control, pull knob out. Slowly push knob in to disengage.

TO MOVE FORWARD AND BACKWARD (See Fig. 8)

The direction and speed of movement is controlled by the motion control lever.

- Start tractor with motion control lever in neutral (N) position.
- Release parking brake and clutch/brake pedal.
- Slowly move motion control lever to desired position.

TO ADJUST MOWER CUTTING HEIGHT (See Fig. 8)

The cutting height is controlled by turning the height adjustment knob in desired direction.

- Turn knob clockwise (↻) to raise cutting height.
- Turn knob counterclockwise (↺) to lower cutting height.

The cutting height range is approximately 1-1/2" to 4". The heights are measured from the ground to the blade tip with the engine not running. These heights are approximate and may vary depending upon soil conditions, height of grass and types of grass being mowed.

- The average lawn should be cut to approximately 2-1/2 inches during the cool season and to over 3 inches during hot months. For healthier and better looking lawns, mow often and after moderate growth.
- For best cutting performance, grass over 6 inches in height should be mowed twice. Make the first cut relatively high; the second to desired height.

OPERATION

TO OPERATE MOWER (See Fig. 9)

Your tractor is equipped with an operator presence sensing switch. Any attempt by the operator to leave the seat with the engine running and the attachment clutch engaged will shut off the engine.

- Select desired height of cut.
- Lower mower with attachment lift control.
- Start mower blades by engaging attachment clutch control.
- TO STOP MOWER BLADES - disengage attachment clutch control.

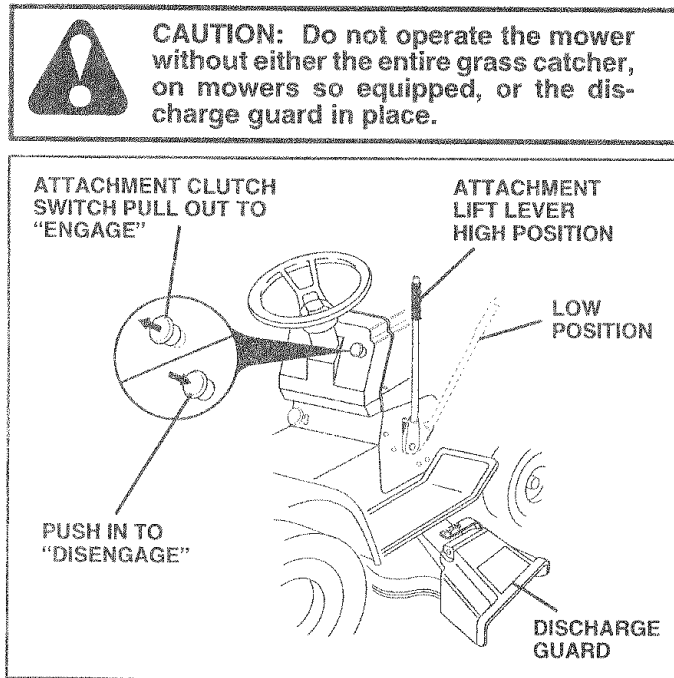
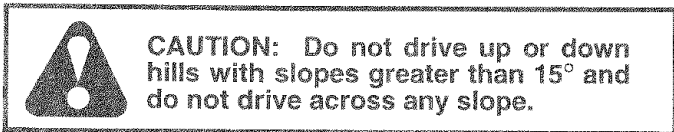

FIG. 9

TO OPERATE ON HILLS



- Choose the slowest speed before starting up or down hills.
- Avoid stopping or changing speed on hills.
- If slowing is necessary, move throttle control lever to slower position.
- If stopping is absolutely necessary, push clutch/brake pedal quickly to brake position and engage parking brake.
- Move motion control lever to neutral (N) position.

IMPORTANT: THE MOTION CONTROL LEVER DOES NOT RETURN TO NEUTRAL (N) POSITION WHEN THE CLUTCH/BRAKE PEDAL IS DEPRESSED.

- To restart movement, slowly release parking brake and clutch/brake pedal.

- Slowly move motion control lever to slowest setting.
- Make all turns slowly.

TO TRANSPORT (See Figs. 9 and 10)

When pushing or towing your tractor, be sure to disengage transmission by placing freewheel control in freewheeling position. Free wheel control is located at the rear drawbar of tractor.

- Raise attachment lift to highest position with attachment lift control.
- Pull freewheel control knob out and hold in position by inserting retainer spring into forward hole of control rod.
- Do not push or tow tractor at more than two (2) MPH.
- To reengage transmission, reverse above procedure.

NOTE: To protect hood from damage when transporting your tractor on a truck or a trailer, be sure hood is closed and secured to tractor. Use an appropriate means of tying hood to tractor (rope, cord, etc.).

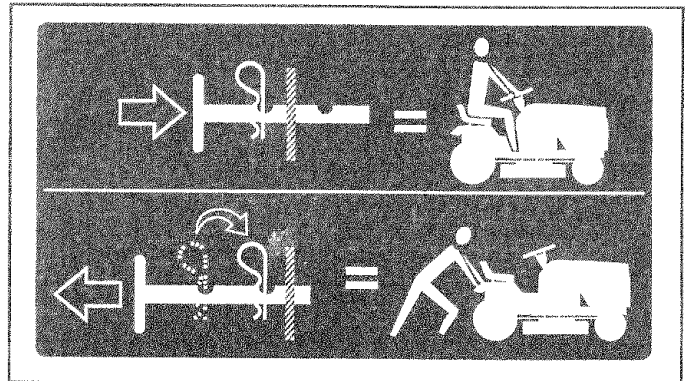

FIG. 10

BEFORE STARTING THE ENGINE

CHECK ENGINE OIL LEVEL (See Fig. 16)

- The engine in your tractor has been shipped, from the factory, already filled with summer weight oil.
- Check engine oil with tractor on level ground.
- Remove oil fill cap/dipstick and wipe clean, reinsert the dipstick and push it all the way down into the tube, wait for a few seconds, remove and read oil level. If necessary, add oil until "FULL" mark on dipstick is reached. Do not overfill.
- For cold weather operation you should change oil for easier starting (See "OIL VISCOSITY CHART" in the Customer Responsibilities section of this manual).
- To change engine oil, see the Customer Responsibilities section in this manual.

OPERATION

ADD GASOLINE

- Fill fuel tank. Use fresh, clean, regular unleaded gasoline. (Use of leaded gasoline will increase carbon and lead oxide deposits and reduce valve life).

IMPORTANT: WHEN OPERATING IN TEMPERATURES BELOW 32°F(0°C), USE FRESH, CLEAN WINTER GRADE GASOLINE TO HELP INSURE GOOD COLD WEATHER STARTING.

WARNING: Experience indicates that alcohol blended fuels (called gasohol or using ethanol or methanol) can attract moisture which leads to separation and formation of acids during storage. Acidic gas can damage the fuel system of an engine while in storage. To avoid engine problems, the fuel system should be emptied before storage of 30 days or longer. Drain the gas tank, start the engine and let it run until the fuel lines and carburetor are empty. Use fresh fuel next season. See Storage Instructions for additional information. Never use engine or carburetor cleaner products in the fuel tank or permanent damage may occur.



CAUTION: Fill to bottom of gas tank filler neck. Do not overfill. Wipe off any spilled oil or fuel. Do not store, spill or use gasoline near an open flame.

TO START ENGINE (See Fig. 8)

When starting engine for the first time or if engine has run out of fuel, it will take extra cranking time to move fuel from the tank to the engine.

- Depress clutch/brake pedal and set parking brake.
- Place motion control lever in neutral (N) position.
- Move attachment clutch to "DISENGAGED" position.
- Pull choke control out to choke (|N|) position for cold engine start. For warm engine start do not use choke control.
- Move throttle control to midway between fast (↻) and slow (↻) positions.
- Insert key into ignition and turn key clockwise to "START" position and release key as soon as engine starts. Do not run starter continuously for more than fifteen seconds per minute. If engine does not start after several attempts, move throttle control to fast (↻) position, wait a few minutes and try again.
- When engine starts, slowly push choke control in.
- Move throttle control to fast (↻) position.
- Allow engine to warm up for a few minutes before engaging drive or attachments.

IMPORTANT: COLD STARTING FOR HYDRO (BELOW 40°F) - AFTER STARTING ENGINE AND BEFORE DRIVING, LET TRANSMISSION WARM UP FOR ONE (1) MINUTE BY PLACING MOTION CONTROL LEVER IN NEUTRAL (N) POSITION AND RELEASING CLUTCH/ BRAKE PEDAL.

NOTE: If at a high altitude (above 3000 feet) or in cold temperatures (below 32°F), the carburetor fuel mixture may need to be adjusted for best engine performance. See "TO ADJUST CARBURETOR" in the Service and Adjustments section of this manual.

PURGE TRANSMISSION



CAUTION: Never engage or disengage freewheel lever while the engine is running.

To ensure proper operation and performance, it is recommended that the transmission be purged before operating tractor for the first time. This procedure will remove any trapped air inside the transmission which may have developed during shipping of your tractor.

IMPORTANT: SHOULD YOUR TRANSMISSION REQUIRE REMOVAL FOR SERVICE OR REPLACEMENT, IT SHOULD BE PURGED AFTER REINSTALLATION BEFORE OPERATING THE TRACTOR.

- Place tractor safely on level surface with engine off and parking brake set.
- Disengage transmission by placing freewheel control in freewheeling position (See "TO TRANSPORT" in this section of manual).
- Sitting in the tractor seat, start engine. After the engine is running, move throttle control to slow (↻) position. With motion control lever in neutral (N) position, slowly disengage clutch/brake pedal.
- Move motion control lever to full forward position and hold for five (5) seconds. Move lever to full reverse position and hold for five (5) seconds. Repeat this procedure three (3) times.

NOTE: During this procedure there will be no movement of drive wheels. The air is being removed from hydraulic drive system.

- Move motion control lever to neutral (N) position. Shut-off engine and set parking brake.
- Engage transmission by placing freewheel control in driving position (See "TO TRANSPORT" in this section of manual).
- Sitting in the tractor seat, start engine. After the engine is running, move throttle control to half (1/2) speed. With motion control lever in neutral (N) position, slowly disengage clutch/brake pedal.
- Slowly move motion control lever forward, after the tractor moves approximately five (5) feet, slowly move motion control lever to reverse position. After the tractor moves approximately five (5) feet return the motion control lever to the neutral (N) position. Repeat this procedure with the motion control lever three (3) times.
- Your tractor is now purged and now ready for normal operation.

OPERATION

MOWING TIPS

- Tire chains cannot be used when the mower housing is attached to tractor.
- Mower should be properly leveled for best mowing performance. See "TO LEVEL MOWER HOUSING" in the Service and Adjustments section of this manual.
- The left hand side of mower should be used for trimming.
- Drive so that clippings are discharged onto the area that has been cut. Have the cut area to the right of the machine. This will result in a more even distribution of clippings and more uniform cutting.
- When mowing large areas, start by turning to the right so that clippings will discharge away from shrubs, fences, driveways, etc. After one or two rounds, mow in the opposite direction making left hand turns until finished (See Fig. 11).
- If grass is extremely tall, it should be mowed twice to reduce load and possible fire hazard from dried clippings. Make first cut relatively high; the second to the desired height.
- Do not mow grass when it is wet. Wet grass will plug mower and leave undesirable clumps. Allow grass to dry before mowing.
- Always operate engine at full throttle when mowing to assure better mowing performance and proper discharge of material. Regulate ground speed by selecting a low enough gear to give the mower cutting performance as well as the quality of cut desired.
- When operating attachments, select a ground speed that will suit the terrain and give best performance of the attachment being used.

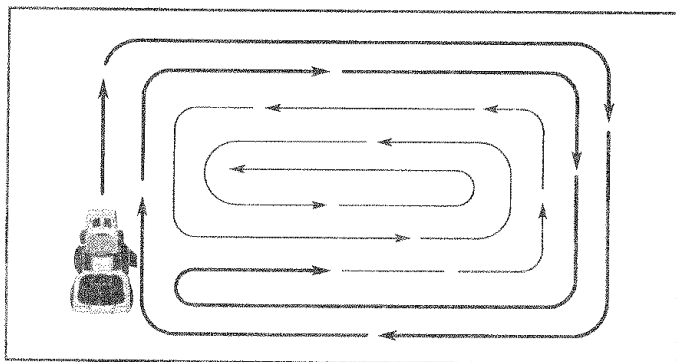

FIG. 11

MULCHING MOWING TIPS

IMPORTANT: FOR BEST PERFORMANCE, KEEP MOWER HOUSING FREE OF BUILT-UP GRASS AND TRASH. CLEAN AFTER EACH USE.

- The special mulching blade will recut the grass clippings many times and reduce them in size so that as they fall onto the lawn they will disperse into the grass and not be noticed. Also, the mulched grass will biodegrade quickly to provide nutrients for the lawn. Always mulch with your highest engine (blade) speed as this will provide the best recutting action of the blades.
- Avoid cutting your lawn when it is wet. Wet grass tends to form clumps and interferes with the mulching action. The best time to mow your lawn is the early afternoon. At this time the grass has dried and the newly cut area will not be exposed to the direct sun.
- For best results, adjust the mower cutting height so that the mower cuts off only the top one-third of the grass blades (See Fig. 12). For extremely heavy mulching, reduce your width of cut on each pass and mow slowly.
- Certain types of grass and grass conditions may require that an area be mulched a second time to completely hide the clippings. When doing a second cut, mow across or perpendicular to the first cut path.
- Change your cutting pattern from week to week. Mow north to south one week then change to east to west the next week. This will help prevent matting and graining of the lawn.

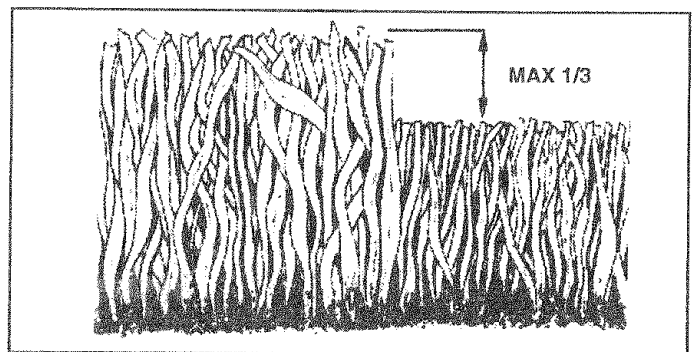

FIG. 12

CUSTOMER RESPONSIBILITIES

MAINTENANCE SCHEDULE FILL IN DATES AS YOU COMPLETE REGULAR SERVICE		SERVICE DATES						
		BEFORE EACH USE	FIRST 2 HOURS	EVERY 8 HOURS	EVERY 25 HOURS	EVERY 50 HOURS	EVERY 100 HOURS	BEFORE STORAGE
TRACTOR	Check Brake Operation	✓	✓					
	Check Tire Pressure	✓	✓					
	Check for Loose Fasteners	✓				✓ ₇	✓	
	Sharpen/Replace Mower Blades			✓ ₄				
	Lubrication Chart			✓			✓	
	Check Battery Level/Recharge			✓ ₆				
	Clean Battery and Terminals			✓			✓	
	Check Transaxle Cooling			✓				
	Adjust Blade Belt(s) Tension					✓ ₅		
	Adjust Motion Drive Belt(s) Tension					✓ ₅		
ENGINE	Check Engine Oil Level	✓	✓					
	Change Engine Oil		✓	✓ _{1,2,3}			✓	
	Clean Air Filter			✓ ₂				
	Clean Air Screen			✓ ₂				
	Inspect Muffler/Spark Arrester				✓			
	Replace Oil Filter (If equipped)					✓ _{1,2}		
	Clean Engine Cooling Fins					✓ ₂		
	Replace Spark Plug					✓	✓	
	Replace Air Filter Paper Cartridge					✓ ₂		
	Replace Fuel Filter						✓	

- 1 - Change more often when operating under a heavy load or in high ambient temperatures.
 2 - Service more often when operating in dirty or dusty conditions.
 3 - If equipped with oil filter, change oil every 50 hours.
 4 - Replace blades more often when mowing in sandy soil.

- 5 - If equipped with adjustable system.
 6 - Not required if equipped with maintenance-free battery.
 7 - Tighten front axle pivot bolt to 35 ft.-lbs. maximum.
 Do not overtighten.

GENERAL RECOMMENDATIONS

The warranty on this tractor does not cover items that have been subjected to operator abuse or negligence. To receive full value from the warranty, operator must maintain tractor as instructed in this manual.

Some adjustments will need to be made periodically to properly maintain your tractor.

All adjustments in the Service and Adjustments section of this manual should be checked at least once each season.

- Once a year you should replace the spark plug, clean or replace air filter, and check blades and belts for wear. A new spark plug and clean air filter assure proper air-fuel mixture and help your engine run better and last longer.

BEFORE EACH USE

- Check engine oil level.
- Check brake operation.
- Check tire pressure.
- Check for loose fasteners.

LUBRICATION CHART

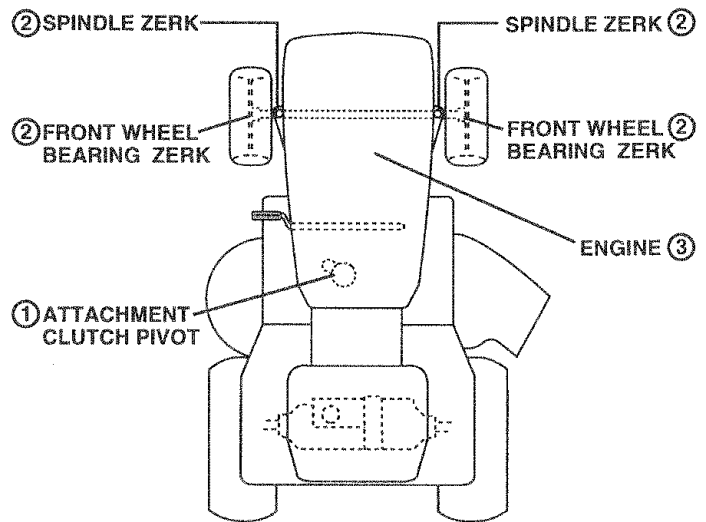

- ① SAE 30 MOTOR OIL
 ② GENERAL PURPOSE GREASE
 ③ REFER TO CUSTOMER RESPONSIBILITIES "ENGINE" SECTION
IMPORTANT: DO NOT OIL OR GREASE THE PIVOT POINTS, WHICH HAVE SPECIAL NYLON BEARINGS. VISCOUS LUBRICANTS WILL ATTRACT DUST AND DIRT THAT WILL SHORTEN THE LIFE OF THE SELF-LUBRICATING BEARINGS. IF YOU FEEL THEY MUST BE LUBRICATED, USE ONLY A DRY, POWDERED GRAPHITE TYPE LUBRICANT SPARINGLY.

CUSTOMER RESPONSIBILITIES

TRACTOR

Always observe safety rules when performing any maintenance.

BRAKE OPERATION

If tractor requires more than six (6) feet stopping distance at high speed in highest gear, then brake must be adjusted. (See "TO ADJUST BRAKE" in the Service and Adjustments section of this manual).

TIRES

- Maintain proper air pressure in all tires (See "PRODUCT SPECIFICATIONS" on page 3 of this manual).
- Keep tires free of gasoline, oil, or insect control chemicals which can harm rubber.
- Avoid stumps, stones, deep ruts, sharp objects and other hazards that may cause tire damage.

BLADE CARE

For best results mower blades must be kept sharp. Replace bent or damaged blades.

BLADE REMOVAL (See Fig. 13)

- Raise mower to highest position to allow access to blades.
- Remove hex bolt, lock washer and flat washer securing blade.
- Install new or resharpened blade with trailing edge up towards deck as shown.
- Reassemble hex bolt, lock washer and flat washer in exact order as shown.
- Tighten bolt securely (30-35 Ft. Lbs. torque).

IMPORTANT: BLADE BOLT IS GRADE 8 HEAT TREATED.

NOTE: We do not recommend sharpening blade - but if you do, be sure the blade is balanced.

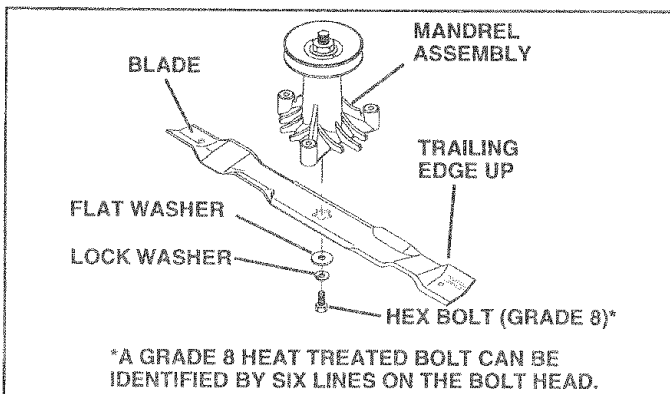

FIG. 13

TO SHARPEN BLADE (See Fig. 14)

Care should be taken to keep the blade balanced. An unbalanced blade will cause excessive vibration and eventual damage to mower and engine.

- The blade can be sharpened with a file or on a grinding wheel. Do not attempt to sharpen while on the mower.
- To check blade balance, you will need a 5/8" diameter steel bolt, pin, or a cone balancer. (When using a cone balancer, follow the instructions supplied with balancer).
- Slide blade on to an unthreaded portion of the steel bolt or pin and hold the bolt or pin parallel with the ground. If blade is balanced, it should remain in a horizontal position. If either end of the blade moves downward, sharpen the heavy end until the blade is balanced.

NOTE: Do not use a nail for balancing blade. The lobes of the center hole may appear to be centered, but are not.

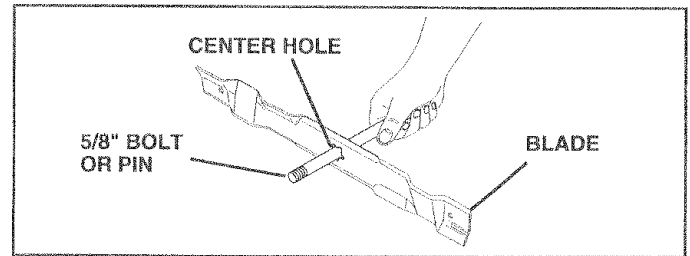

FIG. 14

BATTERY

Your tractor has a battery charging system which is sufficient for normal use. However, periodic charging of the battery with an automotive charger will extend its life.

- Keep battery and terminals clean.
- Keep battery bolts tight.
- Keep small vent holes open (See "CONNECT BATTERY" in the Assembly section of this manual).
- Recharge at 6 amperes for 1 hour.

TO CLEAN BATTERY AND TERMINALS

Corrosion and dirt on the battery and terminals can cause the battery to "leak" power.

- Open battery box door.
- Disconnect BLACK battery cable first then RED battery cable and remove battery from tractor.
- Wash battery with solution of four tablespoons of baking soda to one gallon of water. Be careful not to get the soda solution into the cells.
- Rinse the battery with plain water and dry.
- Clean terminals and battery cable ends with wire brush until bright.
- Coat terminals with grease or petroleum jelly.
- Reinstall battery (See "CONNECT BATTERY" in the Assembly section of this manual).

CUSTOMER RESPONSIBILITIES

TO SERVICE PRE-CLEANER

- Slide foam pre-cleaner off cartridge.
- Wash it in liquid detergent and water.
- Squeeze it dry in a clean cloth.
- Saturate it in engine oil. Wrap it in clean, absorbent cloth and squeeze to remove excess oil.

TO SERVICE CARTRIDGE

- Gently tap the flat side of the paper cartridge to dislodge dirt. Do not wash the paper cartridge or use pressurized air, as this will damage the cartridge. Replace a dirty, bent, or damaged cartridge.
- Reinstall the pre-cleaner (cleaned and oiled) over the paper cartridge.
- Reassemble air cleaner, cartridge plate, and seal.
- Install the air cleaner cover and wing nut. Tighten wing nut 1/2 turn to 1 full turn after nut contacts cover. Do not overtighten.

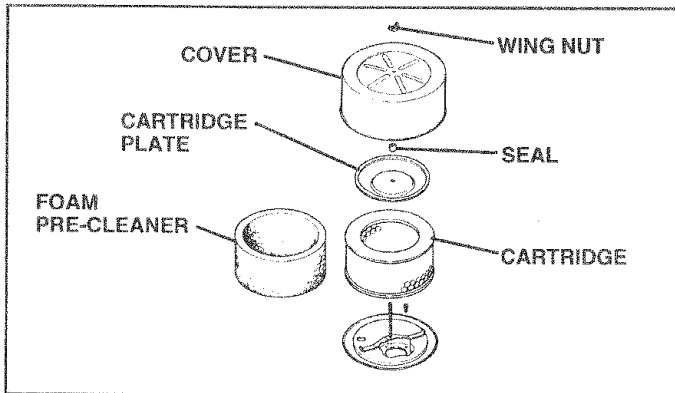

FIG. 17

ENGINE COOLING FINS (See Fig. 18)

Remove any dust, dirt or oil from engine cooling fins to prevent engine damage from overheating. Engine blower housing must be removed. Remove side panels and hood (See "TO REMOVE HOOD AND GRILL ASSEMBLY" in the Service and Adjustments section of this manual).

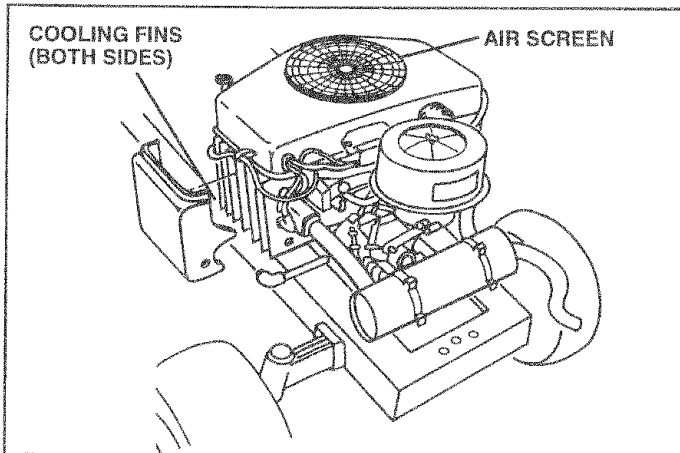

FIG. 18

ENGINE OIL FILTER

Replace the engine oil filter every season or every other oil change if the tractor is used more than 100 hours in one year.

MUFFLER

Inspect and replace corroded muffler and spark arrester (if equipped) as it could create a fire hazard and/or damage.

SPARK PLUGS

Replace spark plugs at the beginning of each mowing season or after every 100 hours of use, whichever comes first. Spark plug type and gap setting is shown in "PRODUCT SPECIFICATIONS" on page 3 of this manual.

IN-LINE FUEL FILTER (See Fig. 19)

The fuel filter should be replaced once each season. If fuel filter becomes clogged, obstructing fuel flow to carburetor, replacement is required.

- With engine cool, remove filter and plug fuel line sections.
- Place new fuel filter in position in fuel line with arrow pointing towards carburetor.
- Be sure there are no fuel line leaks and clamps are properly positioned.
- Immediately wipe up any spilled gasoline.

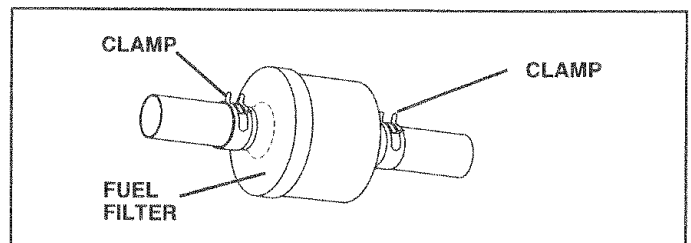

FIG. 19

CLEANING

- Clean engine, battery, seat, finish, etc. of all foreign matter.
- Keep finished surfaces and wheels free of all gasoline, oil, etc.
- Protect painted surfaces with automotive type wax.

We do not recommend using a garden hose to clean your tractor unless the electrical system, muffler, air filter and carburetor are covered to keep water out. Water in engine can result in a shortened engine life.

SERVICE AND ADJUSTMENTS

CAUTION: BEFORE PERFORMING ANY SERVICE OR ADJUSTMENTS:



- Depress clutch/brake pedal fully and set parking brake.
- Place motion control lever in neutral (N) position.
- Place attachment clutch in "DISENGAGED" position.
- Turn ignition key "OFF" and remove key.
- Make sure the blades and all moving parts have completely stopped.
- Disconnect spark plug wire from spark plug and place wire where it cannot come in contact with plug.

TO REMOVE MOWER (See Fig. 20)

Mower will be easier to remove from the right side of tractor.

- Place attachment clutch switch in "DISENGAGED" position.
- Move attachment lift lever forward to lower mower to its lowest position.
- Roll belt off electric clutch pulley.
- Disconnect anti-sway bar from chassis bracket by removing retainer spring.
- Disconnect suspension arms from rear deck brackets by removing retainer springs.
- Disconnect front links from deck by removing retainer springs.
- Raise lift lever to raise suspension arms. Slide mower out from under tractor.

IMPORTANT: IF AN ATTACHMENT OTHER THAN THE MOWER DECK IS TO BE MOUNTED ON THE TRACTOR, REMOVE THE FRONT LINKS.

TO INSTALL MOWER (See Fig. 20)

- Raise attachment lift lever to its highest position.
- Slide mower under tractor with discharge guard to right side of tractor.
- Lower lift lever to its lowest position.
- Install mower in reverse order of removal instructions.

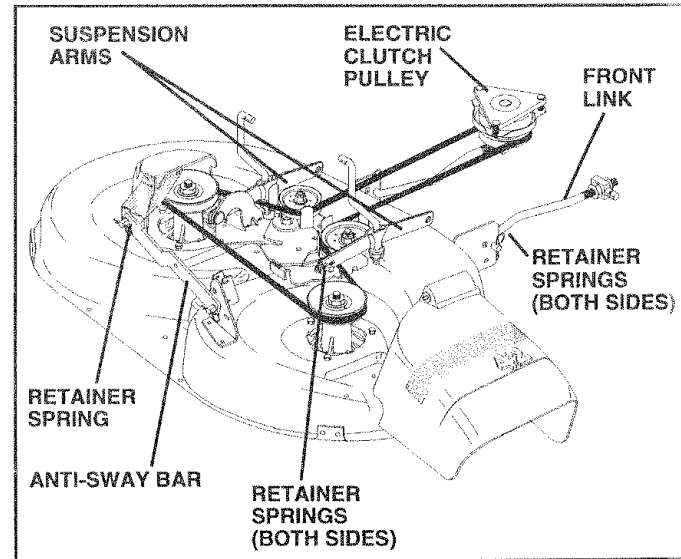

FIG. 20

SERVICE AND ADJUSTMENTS

TO LEVEL MOWER HOUSING

Adjust the mower while tractor is parked on level ground or driveway. Make sure tires are properly inflated (See "PRODUCT SPECIFICATIONS" on page 3 of this manual). If tires are over or underinflated, you will not properly adjust your mower.

SIDE-TO-SIDE ADJUSTMENT (See Figs. 21 and 22)

- Raise mower to its highest position.
- At the midpoint of both sides of mower, measure height from bottom edge of mower to ground. Distance "A" on both sides of mower should be the same or within 1/4" of each other.
- If adjustment is necessary, make adjustment on one side of mower only.
- To raise one side of mower, tighten lift link adjustment nut on that side.
- To lower one side of mower, loosen lift link adjustment nut on that side.

NOTE: Each full turn of adjustment nut will change mower height about 1/8".

- Recheck measurements after adjusting.

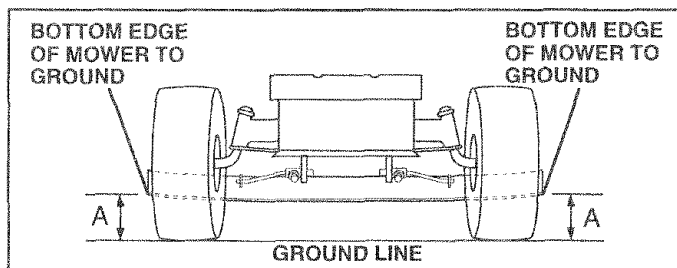

FIG. 21

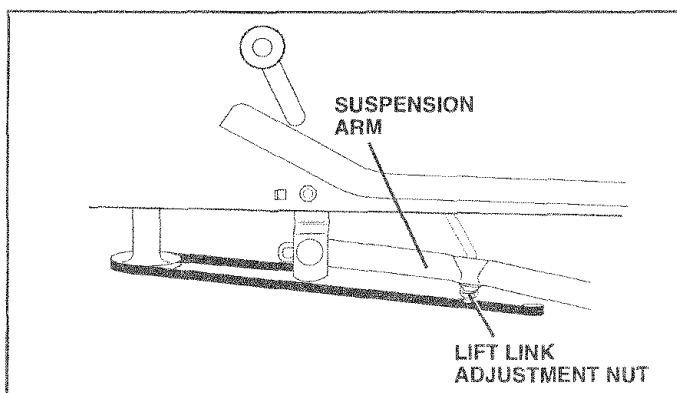

FIG. 22

FRONT-TO-BACK ADJUSTMENT (See Figs. 23 and 24)

IMPORTANT: DECK MUST BE LEVEL SIDE-TO-SIDE. IF THE FOLLOWING FRONT-TO-BACK ADJUSTMENT IS NECESSARY, BE SURE TO ADJUST BOTH FRONT LINKS EQUALLY SO MOWER WILL STAY LEVEL SIDE-TO-SIDE.

To obtain the best cutting results, the mower housing should be adjusted so that the front is approximately 1/4" to 3/4" lower than the rear when the mower is in its highest position.

Check adjustment on right side of tractor. Measure distance "D" directly in front and behind the mandrel at bottom edge of mower housing as shown.

- Before making any necessary adjustments, check that both front links are equal in length. Both links should be approximately 10-3/8".
- If links are not equal in length, adjust one link to same length as other link.
- To lower front of mower loosen nut "E" on both front links an equal number of turns.
- When distance "D" is 1/4" to 3/4" lower at front than rear, tighten nuts "F" against trunnion on both front links.
- To raise front of mower, loosen nut "F" from trunnion on both front links. Tighten nut "E" on both front links an equal number of turns.
- When distance "D" is 1/4" to 3/4" lower at front than rear, tighten nut "F" against trunnion on both front links.
- Recheck side-to-side adjustment.

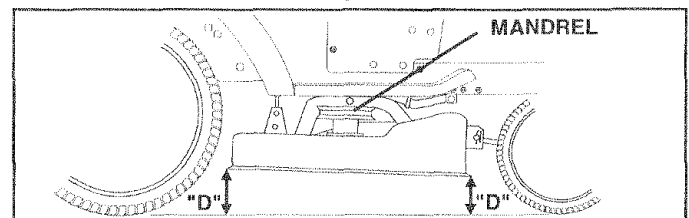

FIG. 23

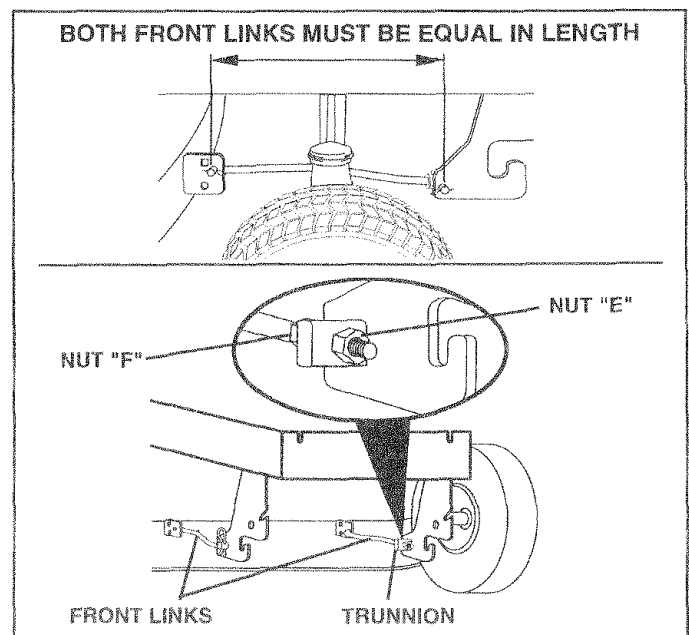

FIG. 24

SERVICE AND ADJUSTMENTS

TO REPLACE MOWER BLADE DRIVE BELT (See Fig. 25)

The mower blade drive belt may be replaced without tools. Park the tractor on level surface. Engage parking brake.

BELT REMOVAL -

- Remove mower from tractor (See "TO REMOVE MOWER" in this section of this manual).
- Work belt off both mandrel pulleys and idler pulleys.
- Pull belt away from mower.

BELT INSTALLATION -

- Install new belt in reverse order of removal.
- Make sure belt is in all pulley grooves and inside all belt guides.
- Install mower in reverse order of removal instructions.

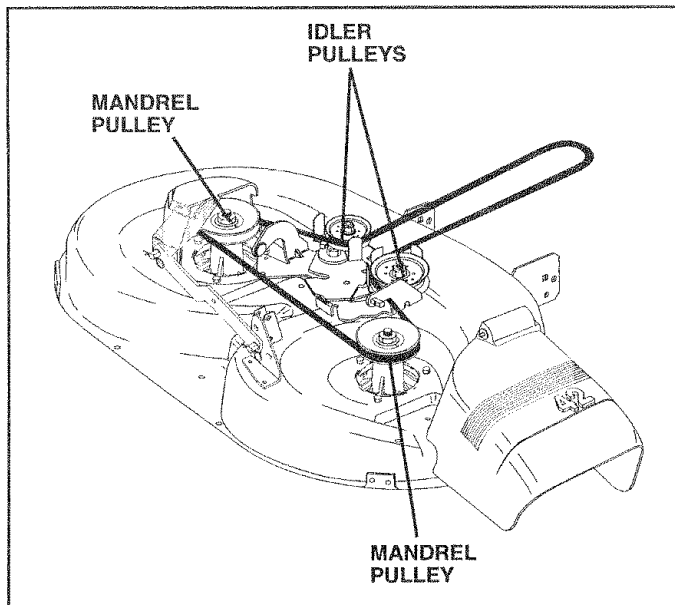

FIG. 25

TO ADJUST BRAKE (See Fig. 26)

Your tractor is equipped with an adjustable brake system which is mounted on the right side of the transaxle.

If tractor requires more than six (6) feet stopping distance at high speed in highest gear, then brake must be adjusted.

- Depress clutch/brake pedal and engage parking brake.
- Measure distance between brake operating arm and nut "A" on brake rod.
- If distance is other than 1-3/4", loosen jam nut and turn nut "A" until distance becomes 1-3/4". Retighten jam nut against nut "A".
- Road test tractor for proper stopping distance as stated above. Readjust if necessary. If stopping distance is still greater than six (6) feet in highest gear, further maintenance is necessary. Contact your nearest authorized service center.

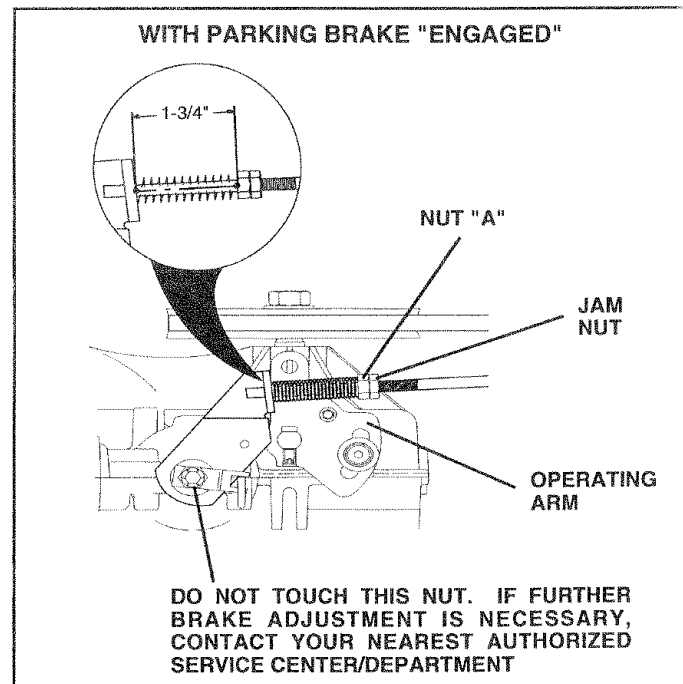

FIG. 26

SERVICE AND ADJUSTMENTS

TO REPLACE MOTION DRIVE BELT (See Fig. 27)

Park the tractor on level surface. Engage parking brake. For assistance, there is a belt installation guide decal on bottom side of left footrest.

- Remove mower (See "TO REMOVE MOWER" in this section of this manual.)
- Disconnect clutch wire harness.
- Remove clutch locator.
- Remove upper belt keeper.
- Remove belt from stationary idler and clutching idler.
- Pull belt slack toward rear of tractor. Carefully remove belt upwards from transmission input pulley and over cooling fan blades.
- Pull belt toward front of tractor and remove downwards from around electric clutch.
- Install new belt by reversing above procedure.

IMPORTANT: MAKE SURE UPPER BELT KEEPER IS POSITIONED PROPERLY BETWEEN LOCATOR TABS AND ELECTRIC CLUTCH WIRE CONNECTION IS SECURE.

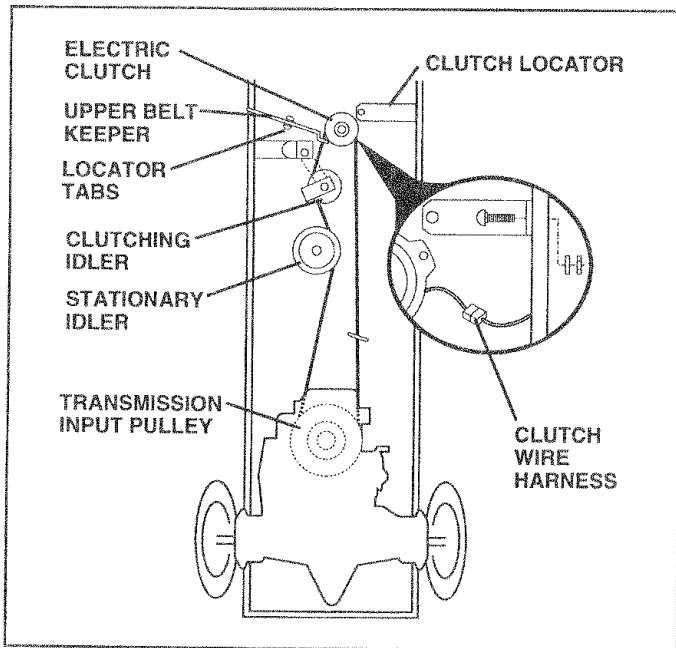

FIG. 27

TO ADJUST MOTION CONTROL LEVER (See Fig. 28)

The motion control lever has been preset at the factory and adjustment should not be necessary.

If for any reason the motion control lever will not hold its position while at a selected speed, it may be adjusted at the friction pack located on the right side of transmission.

- Park tractor on level surface. Stop tractor by turning ignition key to "OFF" position, and engage parking brake.
- Adjust motion control lever by tightening adjustment locknut one half (1/2) turn.

NOTE: If for any reason the effort to move the motion control lever becomes too excessive, reverse the above adjustment procedure by loosening locknut 1/4 to 1/2 turn.

Road test tractor after adjustment and repeat procedure if necessary.

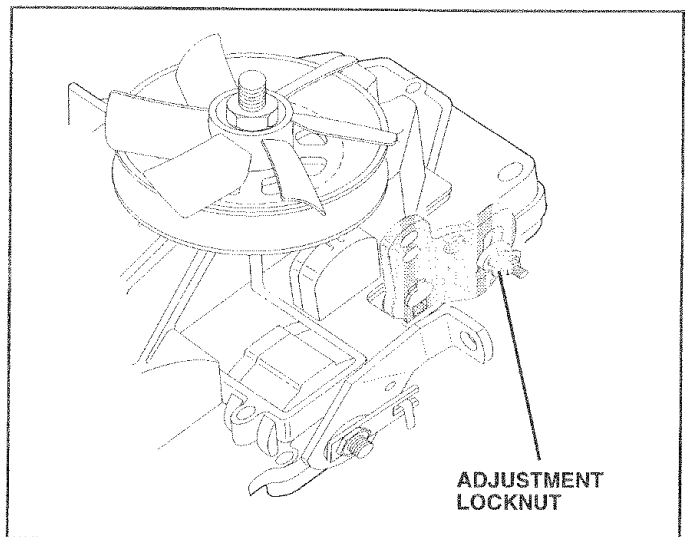

FIG. 28

TRANSMISSION REMOVAL/REPLACEMENT

Should your transmission require removal for service or replacement, it should be purged after reinstallation and before operating the tractor. See "PURGE TRANSMISSION" in Operation section of this manual.

SERVICE AND ADJUSTMENTS

TO ADJUST STEERING WHEEL ALIGNMENT

If steering wheel crossbars are not horizontal (left to right) when wheels are positioned straight forward, remove steering wheel and reassemble per instructions in the Assembly section of this manual.

FRONT WHEEL TOE-IN/CAMBER

The front wheel toe-in and camber are not adjustable on your tractor. If damage has occurred to affect the front wheel toe-in or camber, contact your nearest authorized service center/department.

TO REMOVE WHEEL FOR REPAIRS (See Fig. 29)

- Block up axle securely.
- Remove axle cover, retaining ring and washers to allow wheel removal (rear wheel contains a square key - Do not lose).
- Repair tire and reassemble.
- On rear wheels only: align grooves in rear wheel hub and axle. Insert square key.
- Replace washers and snap retaining ring securely in axle groove.
- Replace axle cover.

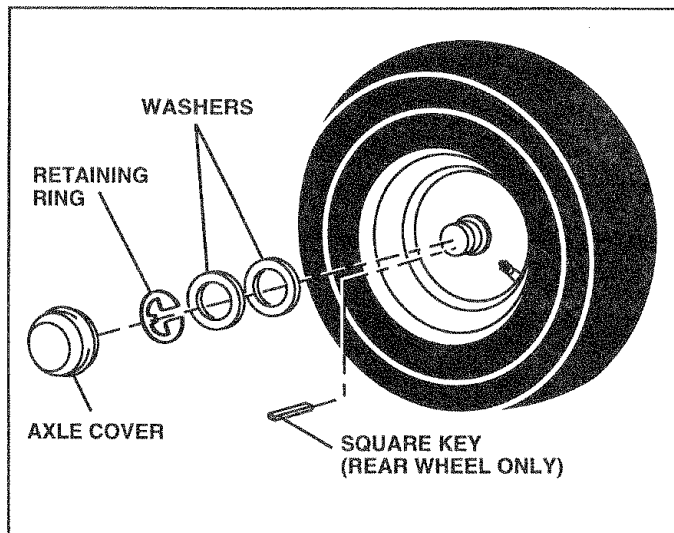

FIG. 29

TO START ENGINE WITH A WEAK BATTERY (See Fig. 30)



CAUTION: Lead-acid batteries generate explosive gases. Keep sparks, flame and smoking materials away from batteries. Always wear eye protection when around batteries.

If your battery is too weak to start the engine, it should be recharged. If "jumper cables" are used for emergency starting, follow this procedure:

IMPORTANT: YOUR TRACTOR IS EQUIPPED WITH A 12 VOLT NEGATIVE GROUNDED SYSTEM. THE OTHER VEHICLE MUST ALSO BE A 12 VOLT NEGATIVE GROUNDED SYSTEM. DO NOT USE YOUR TRACTOR BATTERY TO START OTHER VEHICLES.

TO ATTACH JUMPER CABLES -

- Connect each end of the RED cable to the POSITIVE (+) terminal of each battery, taking care not to short against chassis.
- Connect one end of the BLACK cable to the NEGATIVE (-) terminal of fully charged battery.
- Connect the other end of the BLACK cable to good CHASSIS GROUND, away from fuel tank and battery.

TO REMOVE CABLES, REVERSE ORDER -

- BLACK cable first from chassis and then from the fully charged battery.
- RED cable last from both batteries.

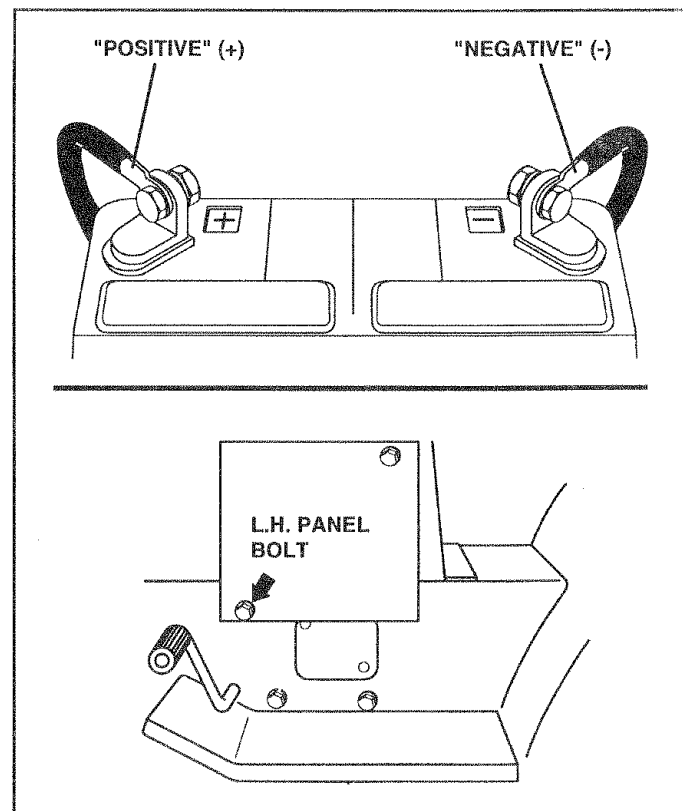

FIG. 30

SERVICE AND ADJUSTMENTS

TO REPLACE HEADLIGHT BULB

- Raise hood.
- Pull bulb holder out of the hole in the backside of the grill.
- Replace bulb in holder and push bulb holder securely back into the hole in the backside of the grill.
- Close hood.

INTERLOCKS AND RELAYS

Loose or damaged wiring may cause your tractor to run poorly, stop running, or prevent it from starting.

- Check wiring. See electrical wiring diagram in the Repair Parts section of this manual.

TO REPLACE FUSE

Replace with 30 amp automotive-type plug-in fuse. The fuse holder is located behind the dash.

TO REMOVE HOOD AND GRILL ASSEMBLY (See Fig. 31)

- Raise hood.
- Unsnap headlight wire connector.
- Stand in front of tractor. Grasp hood at sides, tilt toward engine and lift off of tractor.
- To replace, reverse above procedures.

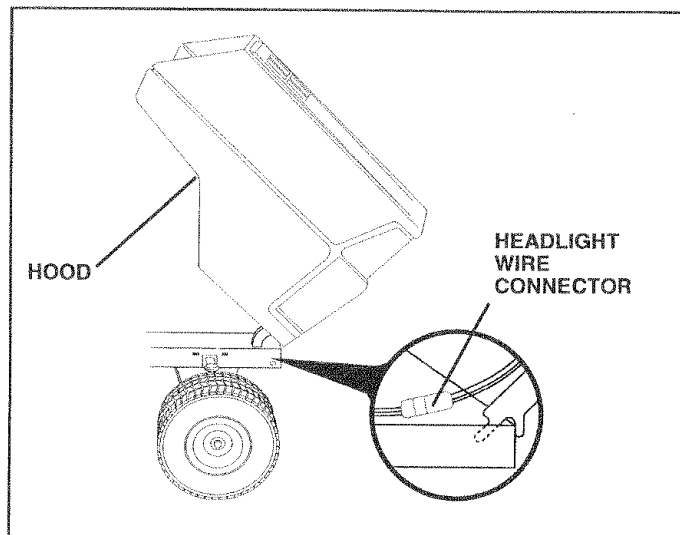

FIG. 31

SERVICE AND ADJUSTMENTS

ENGINE

TO ADJUST THROTTLE CONTROL CABLE (See Fig. 32 and 33)

The throttle control has been preset at the factory and adjustment should not be necessary. Check adjustment as described below before loosening cable. If adjustment is necessary, proceed as follows:

- With engine not running, move throttle control lever to fast (☛) position.
- Check that speed control lever is against stop screw. If it is not, loosen casing clamp screw and pull throttle cable until lever is against screw. Tighten clamp screw securely.

TO ADJUST CARBURETOR (See Fig. 34)

The carburetor has been present at the factory and adjustment should not be necessary. However, minor adjustment may be required to compensate for differences in fuel, temperature, altitude or load. If the carburetor does need adjustment, proceed as follows:

In general, turning the adjusting needles **in** (clockwise) decreases the supply of fuel to the engine giving a leaner fuel/air mixture. Turning the adjusting needles **out** (counterclockwise) increases the supply of fuel to the engine giving a richer fuel/air mixture.

IMPORTANT: DAMAGE TO THE NEEDLES AND THE SEATS IN CARBURETOR MAY RESULT IF SCREW IS TURNED IN TOO TIGHT.

PRELIMINARY SETTING -

- Be sure you have a clean air filter, and the throttle control cable is adjusted properly (see above).
- With engine off turn idle fuel adjusting needle **in** (clockwise) closing it finger tight and then turn **out** (counterclockwise) 1-1/4 turns.
- Turn main fuel adjusting needle **in** (clockwise) closing finger tight and then turn **out** (counterclockwise) 1 turn.

FINAL SETTING -

- Start engine and allow to warm for five minutes. Make final adjustments with engine running and shift/motion control lever in neutral (N) position.
- With throttle control lever in fast (☛) position, turn main fuel adjusting needle **in** (clockwise) until engine begins to die then turn **out** (counterclockwise) until engine runs rough. Turn needle to a point midway between those two positions.
- **Idle speed setting** - With throttle control lever in slow (☚) position, engine should idle at 1400 RPM. If engine idles too slow or fast, turn idle speed adjusting screw in or out until correct idle is attained.
- **Idle fuel needle setting** - With throttle control lever in slow (☚) position, turn idle fuel adjusting needle **in** (clockwise) until engine begins to die and then turn **out** (counterclockwise) until engine runs rough. Turn needle to a point midway between those two positions.
- Recheck idle speed. Readjust if necessary.

ACCELERATION TEST -

- Move throttle control lever from slow (☚) to fast (☛) position. If engine hesitates or dies, turn idle mixture screw **out** (counterclockwise) 1/8 turn. Repeat test and continue to adjust, if necessary, until engine accelerates smoothly.

High speed stop is factory adjusted. Do not adjust-damage may result.

IMPORTANT: NEVER TAMPER WITH THE ENGINE GOVERNOR, WHICH IS FACTORY SET FOR PROPER ENGINE SPEED. OVERSPEEDING THE ENGINE ABOVE THE FACTORY HIGH SPEED SETTING CAN BE DANGEROUS. IF YOU THINK THE ENGINE-GOVERNED HIGH SPEED NEEDS ADJUSTING, CONTACT YOUR NEAREST AUTHORIZED SERVICE CENTER/DEPARTMENT, WHICH HAS PROPER EQUIPMENT AND EXPERIENCE TO MAKE ANY NECESSARY ADJUSTMENTS.

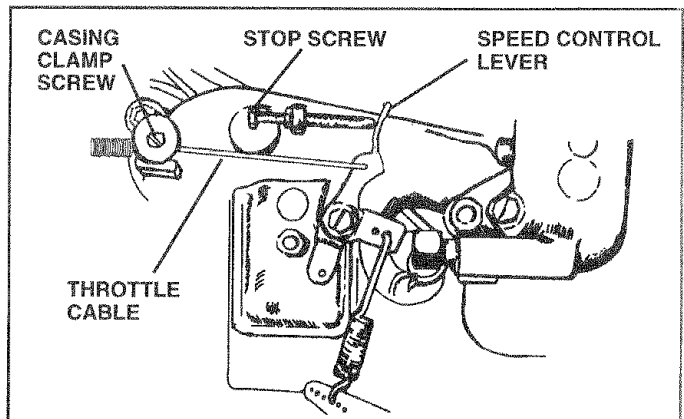

FIG. 32

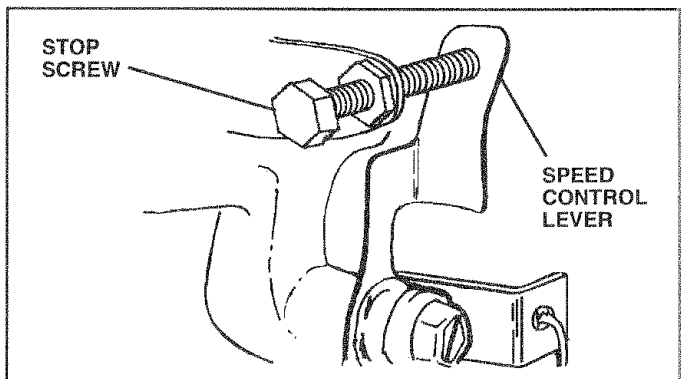

FIG. 33

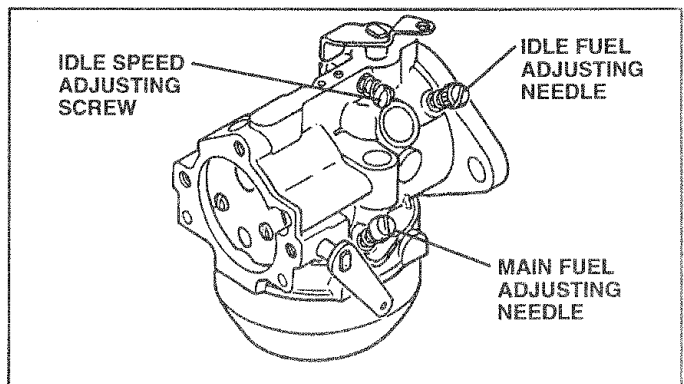

FIG. 34

STORAGE

Immediately prepare your tractor for storage at the end of the season or if the tractor will not be used for 30 days or more.



CAUTION: Never store the tractor with gasoline in the tank inside a building where fumes may reach an open flame or spark. Allow the engine to cool before storing in any enclosure.

TRACTOR

Remove mower from tractor for winter storage. When mower is to be stored for a period of time, clean it thoroughly, remove all dirt, grease, leaves, etc. Store in a clean, dry area.

- Clean entire tractor (See "CLEANING" in the Customer Responsibilities section of this manual).
- Inspect and replace belts, if necessary (See belt replacement instructions in the Service and Adjustments section of this manual).
- Lubricate as shown in the Customer Responsibilities section of this manual.
- Be sure that all nuts, bolts and screws are securely fastened. Inspect moving parts for damage, breakage and wear. Replace if necessary.
- Touch up all rusted or chipped paint surfaces; sand lightly before painting.

BATTERY

- Fully charge the battery for storage.
- After a period of time in storage, battery may require recharging.
- To help prevent corrosion and power leakage during long periods of storage, battery cables should be disconnected and battery cleaned thoroughly (see "TO CLEAN BATTERY AND TERMINALS" in the Customer Responsibilities section of this manual).
- After cleaning, leave cables disconnected and place cables where they cannot come in contact with battery terminals.
- Be sure battery drain tube is securely attached.
- If battery is removed from tractor for storage, do not store battery directly on concrete or damp surfaces.

ENGINE

FUEL SYSTEM

IMPORTANT: IT IS IMPORTANT TO PREVENT GUM DEPOSITS FROM FORMING IN ESSENTIAL FUEL SYSTEM PARTS SUCH AS CARBURETOR, FUEL FILTER, FUEL HOSE, OR TANK DURING STORAGE. ALSO, EXPERIENCE INDICATES THAT ALCOHOL BLENDED FUELS (CALLED GASOHOL OR USING ETHANOL OR METHANOL) CAN ATTRACT MOISTURE WHICH LEADS TO SEPARATION AND FORMATION OF ACIDS DURING STORAGE. ACIDIC GAS CAN DAMAGE THE FUEL SYSTEM OF AN ENGINE WHILE IN STORAGE.

- Drain the fuel tank.
- Start the engine and let it run until the fuel lines and carburetor are empty.
- Never use engine or carburetor cleaner products in the fuel tank or permanent damage may occur.
- Use fresh fuel next season.

NOTE: Fuel stabilizer is an acceptable alternative in minimizing the formation of fuel gum deposits during storage. Add stabilizer to gasoline in fuel tank or storage container. Always follow the mix ratio found on stabilizer container. Run engine at least 10 minutes after adding stabilizer to allow the stabilizer to reach the carburetor. Do not drain the gas tank and carburetor if using fuel stabilizer.

ENGINE OIL

Drain oil (with engine warm) and replace with clean engine oil. (See "ENGINE" in the Customer Responsibilities section of this manual).

CYLINDERS

- Remove spark plug(s).
- Pour one ounce of oil through spark plug hole(s) into cylinder(s).
- Turn ignition key to "START" position for a few seconds to distribute oil.
- Replace with new spark plug(s).

OTHER

- Do not store gasoline from one season to another.
- Replace your gasoline can if your can starts to rust. Rust and/or dirt in your gasoline will cause problems.
- If possible, store your tractor indoors and cover it to give protection from dust and dirt.
- Cover your tractor with a suitable protective cover that does not retain moisture. Do not use plastic. Plastic cannot breathe which allows condensation to form and will cause your tractor to rust.

IMPORTANT: NEVER COVER TRACTOR WHILE ENGINE AND EXHAUST AREAS ARE STILL WARM.

TROUBLESHOOTING POINTS

PROBLEM	CAUSE	CORRECTION
Will not start	<ol style="list-style-type: none"> 1. Out of fuel. 2. Engine not "CHOKED" properly. 3. Engine flooded. 4. Bad spark plug. 5. Dirty air filter. 6. Dirty fuel filter. 7. Water in fuel. 8. Loose or damaged wiring. 9. Carburetor out of adjustment. 10. Engine valves out of adjustment. 	<ol style="list-style-type: none"> 1. Fill fuel tank. 2. See "TO START ENGINE" in Operation section. 3. Wait several minutes before attempting to start. 4. Replace spark plug. 5. Clean/replace air filter. 6. Replace fuel filter. 7. Drain fuel tank and carburetor, refill tank with fresh gasoline and replace fuel filter. 8. Check all wiring. 9. Contact an authorized service center/department. 10. Contact an authorized service center/department.
Hard to start	<ol style="list-style-type: none"> 1. Dirty air filter. 2. Bad spark plug. 3. Weak or dead battery. 4. Dirty fuel filter. 5. Stale or dirty fuel. 6. Loose or damaged wiring. 7. Carburetor out of adjustment. 8. Engine valves out of adjustment. 	<ol style="list-style-type: none"> 1. Clean/replace air filter. 2. Replace spark plug. 3. Recharge or replace battery. 4. Replace fuel filter. 5. Drain fuel tank and refill with fresh gasoline. 6. Check all wiring. 7. Contact an authorized service center/department. 8. Contact an authorized service center/department.
Engine will not turn over	<ol style="list-style-type: none"> 1. Clutch/brake pedal not depressed. 2. Attachment clutch is engaged. 3. Weak or dead battery. 4. Blown fuse. 5. Corroded battery terminals. 6. Loose or damaged wiring. 7. Faulty ignition switch. 8. Faulty solenoid or starter. 9. Faulty operator presence switch(es). 	<ol style="list-style-type: none"> 1. Depress clutch/brake pedal. 2. Disengage attachment clutch. 3. Recharge or replace battery. 4. Replace fuse. 5. Clean battery terminals. 6. Check all wiring. 7. Check/replace ignition switch. 8. Check/replace solenoid or starter. 9. Contact an authorized service center/department.
Engine clicks but will not start	<ol style="list-style-type: none"> 1. Weak or dead battery. 2. Corroded battery terminals. 3. Loose or damaged wiring. 4. Faulty solenoid or starter. 	<ol style="list-style-type: none"> 1. Recharge or replace battery. 2. Clean battery terminals. 3. Check all wiring. 4. Check/replace solenoid or starter.
Loss of power	<ol style="list-style-type: none"> 1. Cutting too much grass/too fast. 2. Throttle in "CHOKE" position. 3. Build-up of grass, leaves and trash under mower. 4. Dirty air filter. 5. Low oil level/dirty oil. 6. Faulty spark plug. 7. Dirty fuel filter. 8. Stale or dirty fuel. 9. Water in fuel. 10. Spark plug wire loose. 11. Dirty engine air screen/fins. 12. Dirty/clogged muffler. 13. Loose or damaged wiring. 14. Carburetor out of adjustment. 15. Engine valves out of adjustment. 	<ol style="list-style-type: none"> 1. Set in "Higher Cut" position/reduce speed. 2. Adjust throttle control. 3. Clean underside of mower housing. 4. Clean/replace air filter. 5. Check oil level/change oil. 6. Clean and regap or change spark plug. 7. Replace fuel filter. 8. Drain fuel tank and refill with fresh gasoline. 9. Drain fuel tank and carburetor, refill tank with fresh gasoline and replace fuel filter. 10. Connect and tighten spark plug wire. 11. Clean engine air screen/fins. 12. Clean/replace muffler. 13. Check all wiring. 14. Contact an authorized service center/department. 15. Contact an authorized service center/department.
Excessive vibration	<ol style="list-style-type: none"> 1. Worn, bent or loose blade. 2. Bent blade mandrel. 3. Loose/damaged part(s). 	<ol style="list-style-type: none"> 1. Replace blade. Tighten blade bolt. 2. Replace blade mandrel. 3. Tighten loose part(s). Replace damaged parts.

TROUBLESHOOTING POINTS

PROBLEM	CAUSE	CORRECTION
Engine continues to run when operator leaves seat with attachment clutch engaged	<ol style="list-style-type: none"> Faulty operator-safety presence control system. 	<ol style="list-style-type: none"> Check wiring, switches and connections. If not corrected, contact an authorized service center/ department.
Poor cut - uneven	<ol style="list-style-type: none"> Worn, bent or loose blade. Mower deck not level. Buildup of grass, leaves, and trash under mower. Bent blade mandrel. Clogged mower deck vent holes from buildup of grass, leaves, and trash around mandrels. 	<ol style="list-style-type: none"> Replace blade. Tighten blade bolt. Level mower deck. Clean underside of mower housing. Replace blade mandrel. Clean around mandrels to open vent holes.
Mower blades will not rotate	<ol style="list-style-type: none"> Obstruction in clutch mechanism. Worn/damaged mower drive belt. Frozen idler pulley. Frozen blade mandrel. 	<ol style="list-style-type: none"> Remove obstruction. Replace mower drive belt. Replace idler pulley. Replace blade mandrel.
Poor grass discharge	<ol style="list-style-type: none"> Engine speed too slow. Travel speed too fast. Wet grass. Mower deck not level. Low/uneven tire air pressure. Worn, bent or loose blade. Buildup of grass, leaves and trash under mower. Mower drive belt worn. Blades improperly installed. Improper blades used. Clogged mower deck vent holes from buildup of grass, leaves, and trash around mandrels. 	<ol style="list-style-type: none"> Place throttle control in "FAST" position. Shift to slower speed. Allow grass to dry before mowing. Level mower deck. Check tires for proper air pressure. Replace/sharpen blade. Tighten blade bolt. Clean underside of mower housing. Replace mower drive belt. Reinstall blades sharp edge down. Replace with blades listed in this manual. Clean around mandrels to open vent holes.
Headlight(s) not working (if so equipped)	<ol style="list-style-type: none"> Switch is "OFF". Bulb(s) burned out. Faulty light switch. Loose or damaged wiring. Blown fuse. 	<ol style="list-style-type: none"> Turn switch "ON". Replace bulb(s). Check/replace light switch. Check wiring and connections. Replace fuse.
Battery will not charge	<ol style="list-style-type: none"> Bad battery cell(s). Poor cable connections. Faulty regulator (if so equipped). Faulty alternator. 	<ol style="list-style-type: none"> Replace battery. Check/clean all connections. Replace regulator. Replace alternator.
Tractor "creeps" with motion control lever in "neutral" position (Fender shift models only)	<ol style="list-style-type: none"> Motion control lever is out of adjustment. 	<ol style="list-style-type: none"> Adjust motion control lever.
Loss of drive	<ol style="list-style-type: none"> Freewheel control in "disengaged" position. Motion drive belt worn, damaged, or broken. Air trapped in transmission during shipment or servicing. 	<ol style="list-style-type: none"> Place freewheel control in "engaged" position. Replace motion drive belt. Purge transmission.
Engine "backfires" when turning engine "OFF"	<ol style="list-style-type: none"> Engine throttle control not set at "SLOW" position for 30 seconds before stopping engine. 	<ol style="list-style-type: none"> Move throttle control to "SLOW" position and allow to idle for 30 seconds before stopping engine.

REPAIR PARTS

TRACTOR - - MODEL NUMBER 917.252711

ELECTRICAL

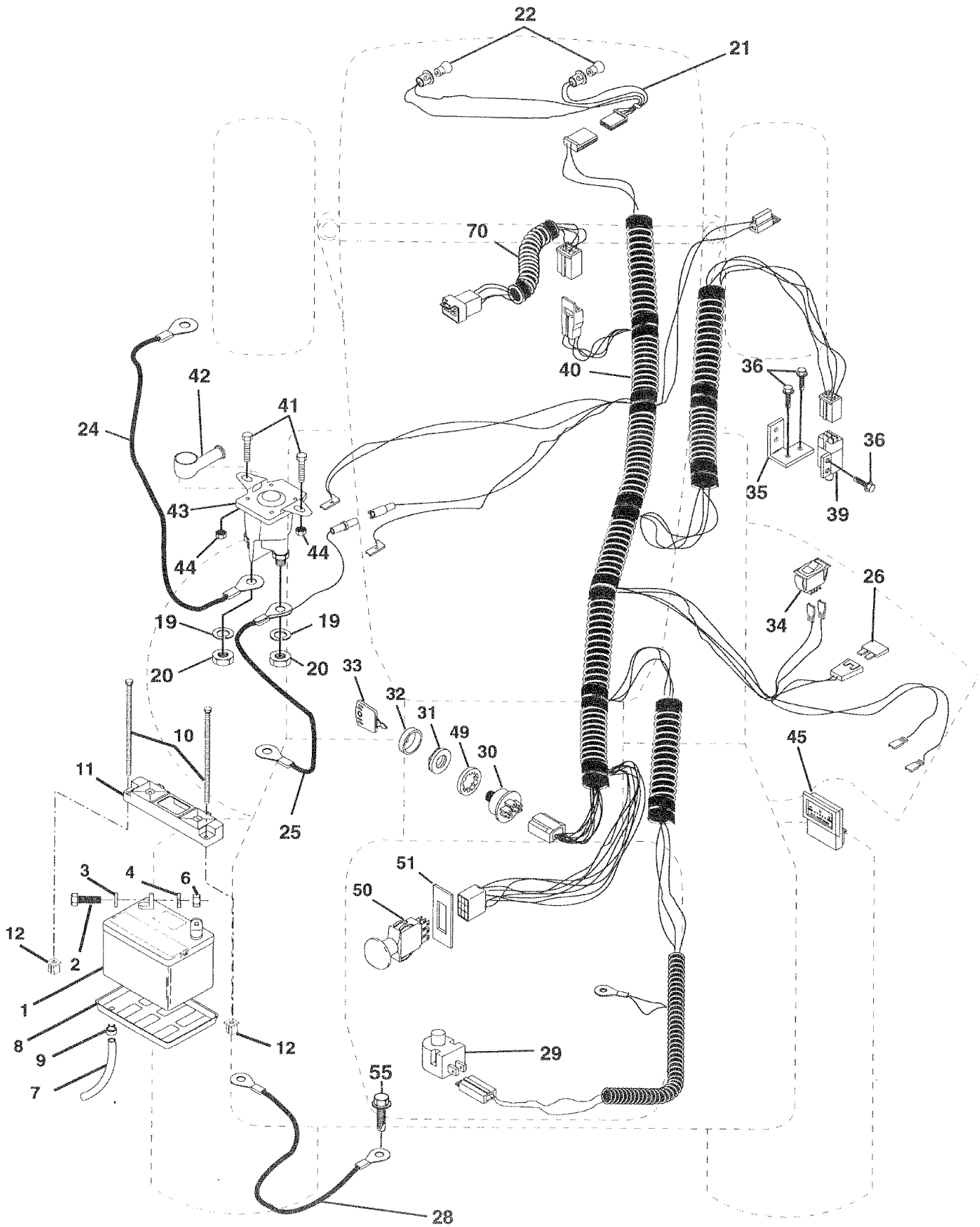

REPAIR PARTS

TRACTOR - - MODEL NUMBER 917.252711

ELECTRICAL

KEY NO.	PART NO.	DESCRIPTION
1	144926	Battery
2	74760412	Bolt, Hex 1/4-20 UNC x 3/4
3	STD551025	Washer
4	STD551125	Washer
6	STD541025	Nut
7	7697J	Tube, Plastic
8	7603J	Tray, Battery
9	109596X	Clamp, Hose
10	145211	Bolt
11	145209	Holddown Battery Dash Mount
12	145769	Nut, Push Nylon 1/4
19	STD551125	Washer, Lock
20	73350400	Nut, Hex, Jam 1/4-20 UNC
21	136850	Harness, Light Socket W/4152J
22	4152J	Bulb, Light
24	146148	Cable, Battery
25	4799J	Cable Battery
26	108824X	Fuse
28	145491	Cable, Ground
29	121305X	Switch, Plunger
30	144921	Switch, Ignition
31	140400	Nut, Ignition
32	141226	Cover, Ignition Switch
33	140403	Key, Ignition
34	110712X	Switch, Light
35	108236X	Bracket, Switch
36	STD601005	Screw
39	109553X	Switch, Interlock
40	149170	Harness, Ignition
41	71110412	Bolt Blk Fin Hex 1/4-20 UNC x 3/4
42	131563	Cover, Terminal
43	145673	Solenoid
44	73800400	Nut, Lock W/Insert 1/4-20 UNC
45	122822X	Ammeter Rectangular 15 Amp.
49	11151000	Washer Lock Internal Tooth 5/8
50	146283	Switch PTO 3 PDT Red Delta
51	140405	Ring Retainer PTO
55	17490508	Screw Thdrol 5/16-18 x 1/2 TYT
70	140427	Harness Engine

NOTE: All component dimensions given in U.S. inches
1 inch = 25.4 mm

REPAIR PARTS

TRACTOR - - MODEL NUMBER 917.252711

CHASSIS AND ENCLOSURES

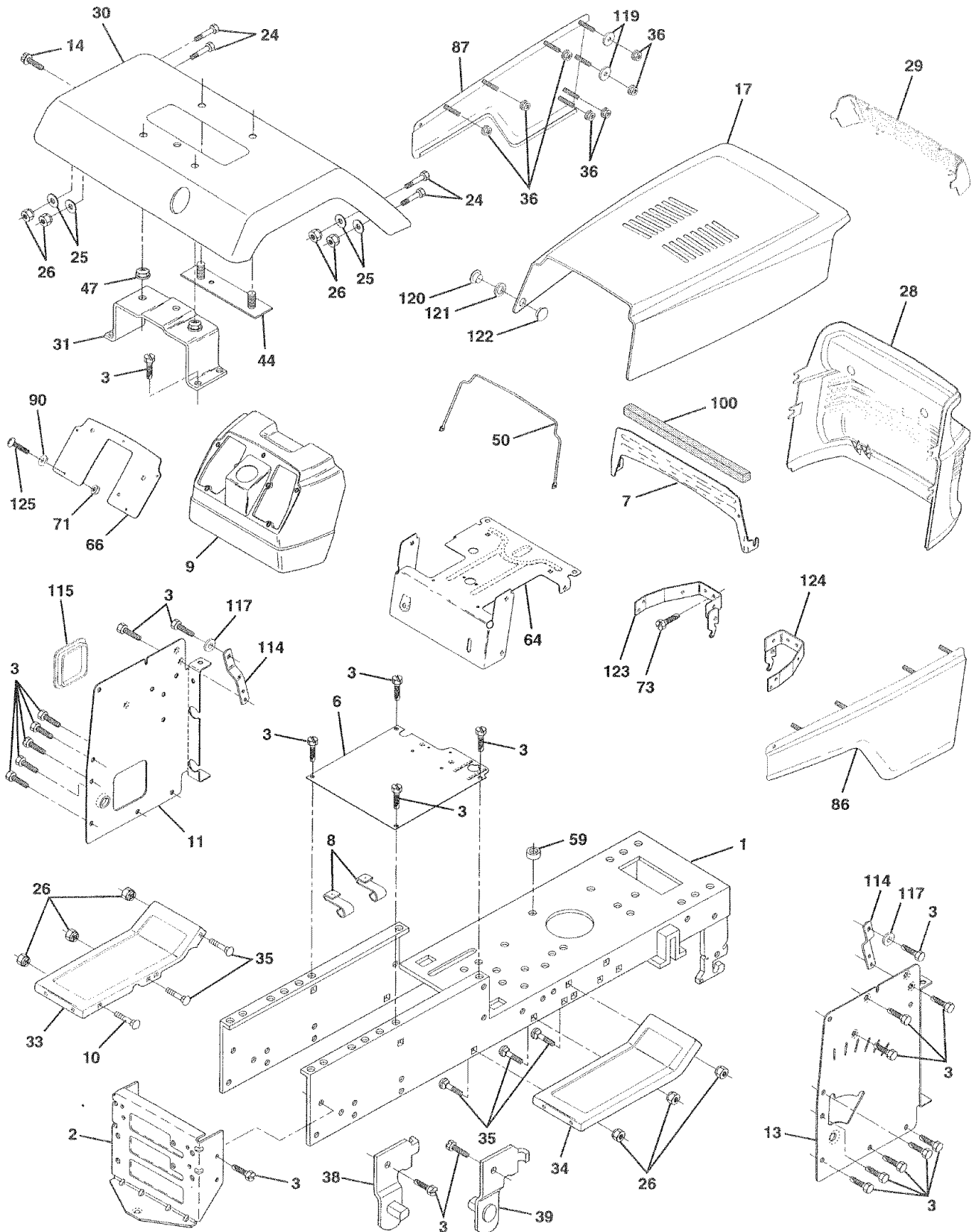

REPAIR PARTS

TRACTOR - - MODEL NUMBER 917.252711

CHASSIS AND ENCLOSURES

KEY NO.	PART NO.	DESCRIPTION	KEY NO.	PART NO.	DESCRIPTION
1	145501	Chassis	44	140675	Fender Strap
2	140356	Drawbar	47	105531X	Nut, Push, Nylon
3	17490612	Screw, Thd., Roll. 3/8-16 x 3/4 Type TT	50	137304	Rod, Support Hood
6	145206	Saddle	59	110436X	Bushing, Snap, Split
7	145351	Heat Shield	64	145095	Dash, Lower
8	126471X	Clip Insulator	66	143485X014	Plate, Dash
9	145203	Dash, Plastic	69	140181	Plate, Support, Battery
10	72140608	Bolt, Carriage 3/8-16 x 1	71	73640400	Nut
11	145218	Panel, Dash, LH	73	17580408	Screw Tap Lite 1/4-20 x 1/2
13	145217	Panel, Dash, RH	75	108067X	Nut, Pal
14	17490608	Screw, Thd., Roll. 3/8-16 x 1/2 Type TT	86	136670X558	Panel Assembly, RH
17	136673X558	Hood Assembly	87	136671X558	Panel Assembly, LH
24	STD523710	Bolt	90	STD551025	Washer 17/64
25	19131312	Washer 13/32 x 13/16 x 12 Gauge	100	105037X	Strip Foam
26	STD541437	Nut	114	145349	Bracket, Support, Dash
28	136373X428	Grill	115	121794X	Cover Access Black Square
29	136374	Lens, Bar, Clear	119	19092016	Washer 9/32 x 1-1/4 x 16 Ga.
30	140002X558	Fender	120	137270	Rivet, Ratchet, Male
31	137113	Bracket Assembly, Fender	121	137269	Washer, Nylon
33	145244X558	Footrest, LH	122	137271	Rivet, Ratchet, Female
34	145243X558	Footrest, RH	123	136814	Bracket Assembly, Front Pivot Hinge, LH
35	STD533707	Bolt	124	136813	Bracket Assembly, Front Pivot Hinge, RH
36	108067X	Nut, Pal	125	74180412	Screw, Machine 1/4-20 x 3/4
38	139886	Bracket Assembly, Pivot, LH			
39	139887	Bracket Assembly, Pivot, RH			

NOTE: All component dimensions given in U.S. inches
1 inch = 25.4 mm

REPAIR PARTS

TRACTOR -- MODEL NUMBER 917.252711

DRIVE

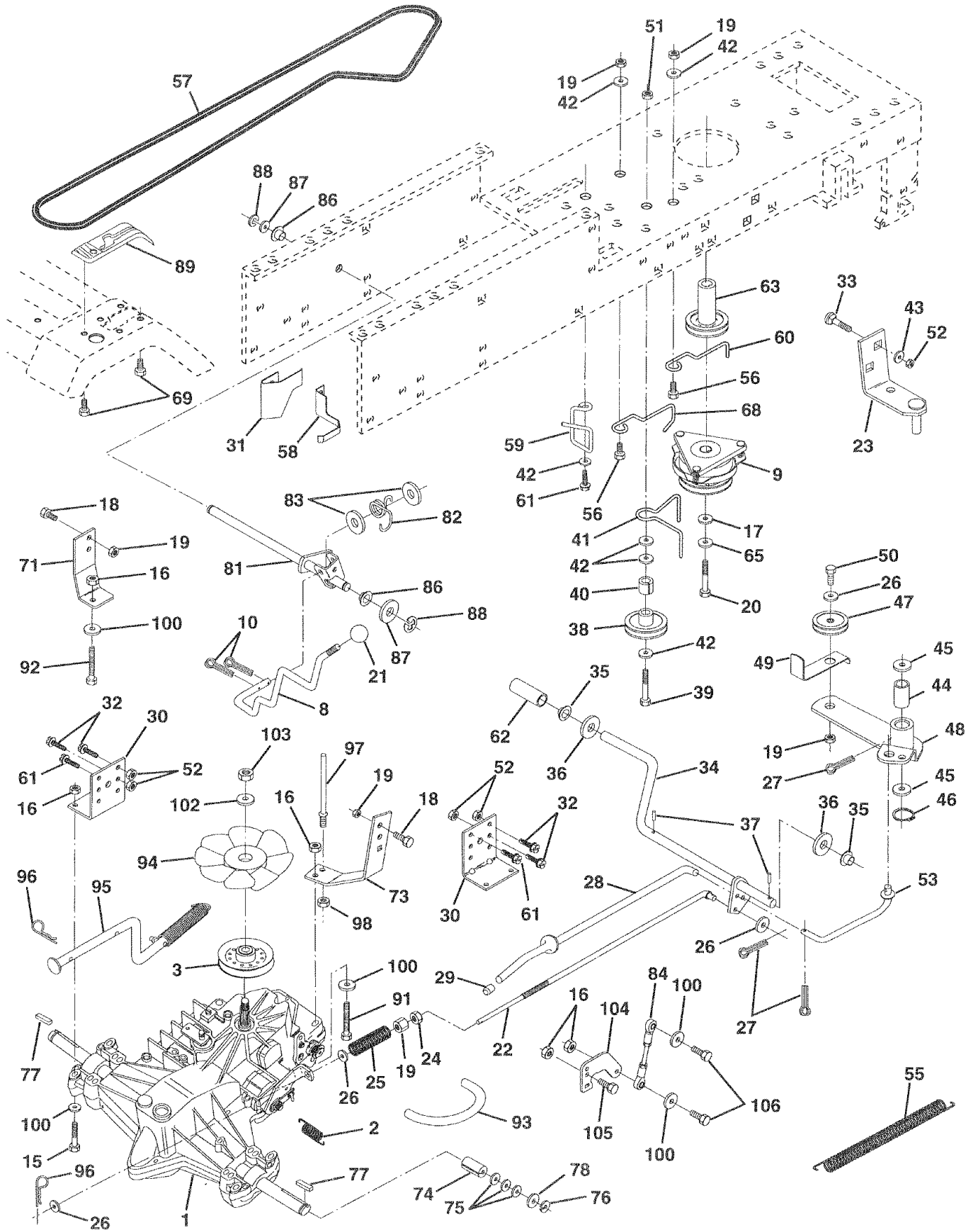

REPAIR PARTS

TRACTOR - - MODEL NUMBER 917.252711

DRIVE

KEY NO.	PART NO.	DESCRIPTION	KEY NO.	PART NO.	DESCRIPTION
1	144436	Transaxle Assembly	56	74760620	Bolt Hex 3/8-16 x 1-1/4
2	142431	Spring, Return, Brake	57	140294	V-Belt, Ground Drive
3	143995	Pulley, Transaxle	58	140470	Keeper Bolt Lh Hydro 0750. 18/20"
8	141002	Rod Shift Hydro LT	59	140312	Keeper, Center Span
9	137140	Clutch Elect	60	121218X	Keeper Belt Engine
10	76020416	Pin Cotter 1/8 x 1 CAD	61	17490612	Screw Thdrol. 3/8-16 x 3/4 Ty. TT
15	74780544	Bolt Fin Hex 5/16-18 Unc	62	8883R	Cover, Pedal
16	73800500	Nut Lock Hex W/Ins. 5/16-18 Unc	63	140186	Pulley, Engine
17	126197X	Washer 1-1/2 OD x 15/32 ID x .250	65	STD551143	Washer Lock Hvy HLCL Spr. 7/16
18	74780616	Bolt Fin Hex 3/8-16 Unc x 1 Gr. 5	67	STD523710	Bolt Fin Hex 3/8-16 x 1
19	73800600	Nut Lock Hex W/Wsh 3/8-16 Unc	68	105730X	Keeper Belt Engine
20	71170768	Bolt Hex 7/16-20 x 4-1/4 Ga. 5	69	142432	Screw
21	130564	Knob, Deluxe 1/2-13	71	140158	Strap Torque Lh Hydro 18/20" T
22	145240	Rod, Brake Hydro	72	19132012	Washer 13/32 x 1-1/4 x 12 Gauge
23	137141	Bracket Asm. Mtg CL	73	140157	Strap Torque Rh Hydro 18/20" T
25	106888X	Spring, Brake Rod	74	121199X	Spacer, Split
26	19131316	Washer	75	121749X	Washer 25/32 x 1-1/4 x 16 Gauge
27	76020412	Pin Cotter 1/8 x 3/4 CAD.	76	12000001	E-Ring
28	145204	Rod, Parking Brake	77	123583X	Key, Square
29	124236X	Cap, Parking Brake	78	121748X	Washer 25/32 x 1-5/8 x 16 Gauge
30	130807	Bracket, Transaxle	81	140154	Shaft Asm. Cross Hydro 20" Tires
31	127275X	Keeper Belt Lh	82	123782X	Spring Torsion T/A
32	74760512	Bolt Hex Hd 5/16-18 Unc x 3/4	83	19171216	Washer 17/32 x 3/4 x 16 Ga.
33	STD533107	Bolt RDHD SQNK 5/16-18 x 3/4	84	140548	Rod, Tie Hydro 20" Tires
34	122424X	Shaft, Foot Pedal	86	71208	Bushing Rod Strig. 629/632 ID
35	120183X	Bearing, Nylon	87	19212016	Washer 21/32 x 1-1/4 x 16 Ga.
36	19211616	Washer	88	12000008	Ring Klip #5304-62
37	1572H	Pin, Roll	89	139989	Console, Shift
38	123674X	Pulley, Idler, Flat	91	74780536	Bolt Fin Hex 5/16-18 x 2-1/4
39	74760644	Bolt	92	74780524	Bolt Fin Hex 5/6-18 Unc x 1-1/2
40	4470J	Spacer, Split	93	142564	Line Fuel Hydro 4"
41	109070X	Keeper, Belt Retainer	94	140462	Fan, Hydro 7"
42	19131312	Washer 13/32 x 13/16 x 12 Gauge	95	144643	Control Bypass Hydro 20" Tires
43	19111012	Washer 11/32 x 5/8 x 12 Ga.	96	4497H	Retainer Spring 1" Zinc/Cad
44	105706X	Bearing, Nylon	97	140469	Keeper Bolt Rh Hydro 0750. 18/20"
45	110812X	Washer, Hardened	98	73510600	Nut Keps Hex 3/8-16 Unc
46	12000039	Ring, Klip	100	19111216	Washer 11/32 x 3/4 x 16 Ga.
47	127783	Pulley, Idler, V-Groove	102	141322	Washer Bellville .501D x 1.50D
48	123789X	Bellcrank Assembly	103	50831	Nut Nylon Insert 1/2-20 Unf.
49	123205X	Retainer, Belt	104	140156	Arm, Control Hydro
50	74760624	Bolt	105	71070516	Screw Cap Hex 5/16 x 18 x 1
51	STD 541437	Nut, Crownlock 3/8-16	106	74780520	Bolt Fin Hex 5/16-18 Unc x 1-1/4
52	73680500	Nut, Crownlock 5/16-18 Unc			
53	105710X	Link, Clutch			
55	105709X	Spring, Return, Clutch			

NOTE: All component dimensions give in U.S. inches.
1 inch = 25.4 mm.

REPAIR PARTS

TRACTOR - - MODEL NUMBER 917.252711

STEERING ASSEMBLY

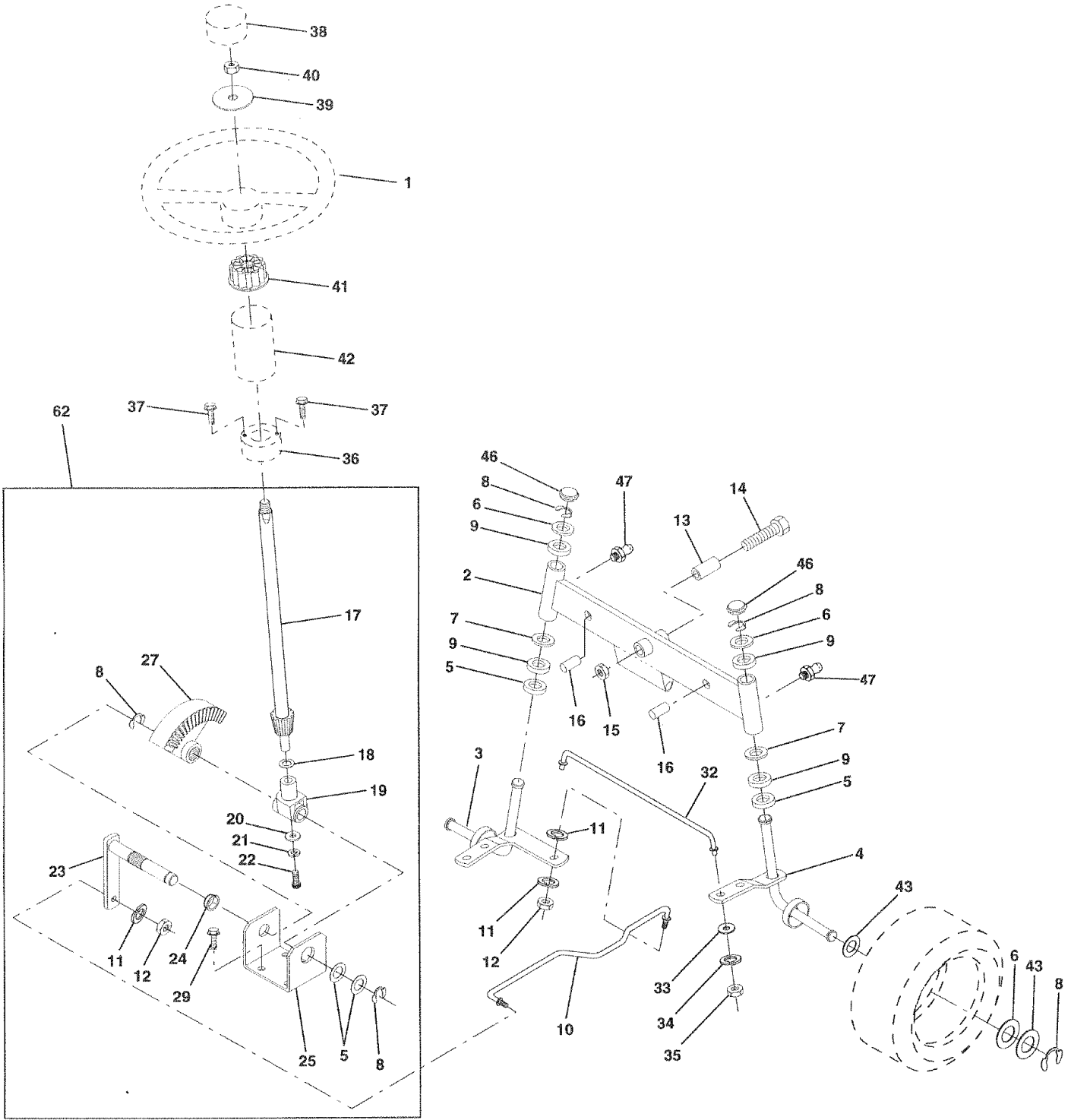

REPAIR PARTS

TRACTOR - - MODEL NUMBER 917.252711

STEERING ASSEMBLY

KEY NO.	PART NO.	DESCRIPTION
1	121472X	Steering Wheel
2	142033	Axle Assembly, Front
3	135227	Spindle Assembly, LH
4	135228	Spindle Assembly, RH
5	6266H	Bearing, Race, Thrust, Hardened
6	121748X	Washer 25/32 x 1-5/8 x 16 Gauge
7	19272016	Washer 27/32 x 1-1/4 x 16 Gauge
8	12000029	Ring, Klip
9	3366R	Bearing
10	130468	Link, Drag
11	STD551137	Washer, Lock
12	73610600	Nut, Hex, Fin. 3/8-24 UNF
13	110438X	Spacer, Bearing, Front Axle
14	74011056	Bolt, Hex 5/8-11 UNC x 3-1/2
15	73901000	Locknut, Hex, Jam, w/Washer Insert 5/8-11 UNC
16	132624	Pin, Axle, Large 5/8 x 1.55/1.54
17	128758	Shaft Assembly, Steering
18	57079	Washer, Thrust .515 x .750 x .033
19	124035X	Support, Shaft
20	126684X	Washer, Shim 1/4 x 5/8 x .062
21	STD551125	Washer
22	71070410	Screw, Hex Socket Head 1/4-20 x 5/8
23	127501	Shaft Assembly, Pittman
24	109816X	Nyliner, Snap-In
25	124036X	Bracket, Steering
27	136874	Gear, Sector
28	19131416	Washer 13/32 x 7/8 x 16 Gauge
29	17490612	Screw, Thd., Roll. 3/8-16 x 3/4 Type TT
32	130467	Tie Rod
33	STD551031	Washer 11/32 x 3/4 x 16 Ga.
34	STD551137	Washer Lock Hvy HLCL Spr. 5/16
35	73810500	Locknut 5/16-24 UNF
37	17541008	Screw SLFTP #10-24 x 1/2 TT-B
36	145207	Bushing, Steering
38	126805X	Insert, Cap, Steering Wheel
39	100712K	Washer .53 x 2.25 x .160
40	STD541350	Nut
41	100711L	Adapter, Steering Wheel
42	140216	Boot Shaft Steering
43	121749X	Washer 25/32 x 1-1/4 x 16 Gauge
45	106933X	Knob, Round
46	121232X	Cap, Spindle
47	6855M	Fitting, Grease131672
62	149682	Kit, Steering Assembly

NOTE: All component dimensions given in U.S. inches
1 inch = 25.4 mm

REPAIR PARTS

TRACTOR - - MODEL NUMBER 917.252711

ENGINE

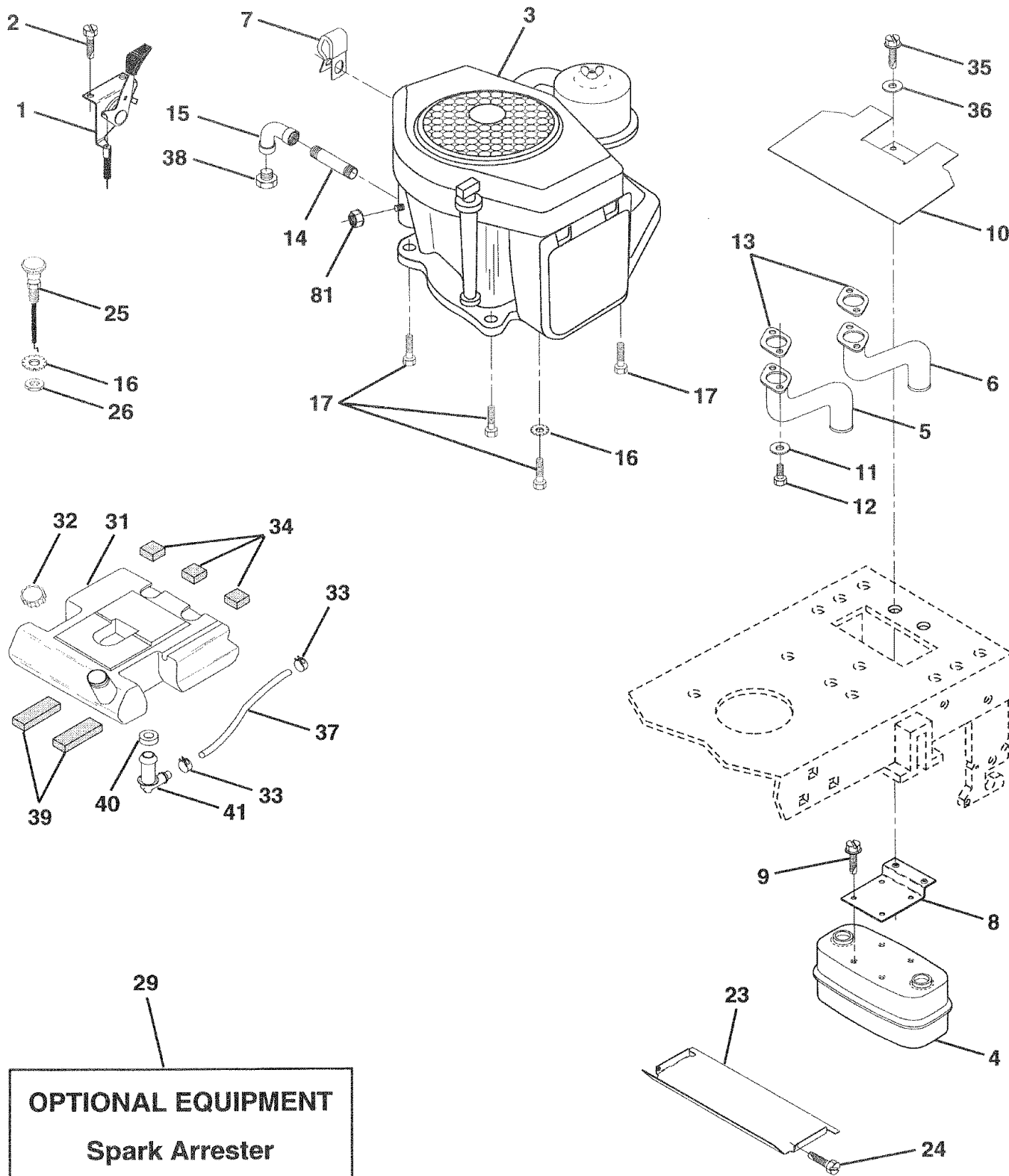

REPAIR PARTS

TRACTOR - - MODEL NUMBER 917.252711

ENGINE

KEY NO.	PART NO.	DESCRIPTION
1	132755	Control, Throttle
2	17720410	Screw, Hex Head, Thread Cutting 1/4-20 x 5/8
3	141948	Engine, Kohler, Model No. MV18S, Type No. PS58560
4	137978	Muffler, Exhaust
5	136215	Tube Manifold LH Kohler MV18
6	136216	Tube Manifold RH Kohler MV18
7	2751R	Clip Line Fuel
8	122439X	Bracket Muffler Mounting
9	17190408	Screw Hex WHS Thdcut 1/4-20 UNC
10	145552	Shield Heat
11	STD551131	Washer Lock Hvy. Hlcl. Spr. 5/16
12	74570512	Screw Hex SKT 5/16 UNC x 3/4
13	-----	Gasket (Order From Engine Manufacturer)
14	13280336	Nipple, Pipe
15	13200300	Elbow, Standard 90°, 3/8-18 NPT
16	11050600	Washer Lock Ext Tooth 3/8
17	17490624	Screw Thdrol 3/8-16 x 1-12 TT
23	128953	Shield, Heat
24	STD601005	Screw
25	138672	Control Choke
26	STD551237	Nut Fin Hex 3/8-24 UNF
29	137180	Arrester, Spark
31	141069	Tank, Fuel
32	123549X	Cap Assembly, Fuel
33	123487X	Clamp, Hose
34	106082X	Spacer, Pad
35	17490512	Screw Thdrol 5/16-18 x 3/4 TYT
36	19132012	Washer 13/32 x 1-1/4 x 12 Ga.
37	8543R	Line, Fuel
38	-----	Plug, Oil Drain (Order From Engine Manufacturer)
39	109227X	Spacer Pad
40	3645J	Bushing
41	139277	Stem, Fuel Tank
81	73510400	Nut Keps Hex 1/4-20 UNC

NOTE: All component dimensions given in U.S. inches
1 inch = 25.4 mm

REPAIR PARTS

TRACTOR - - MODEL NUMBER 917.252711

SEAT ASSEMBLY

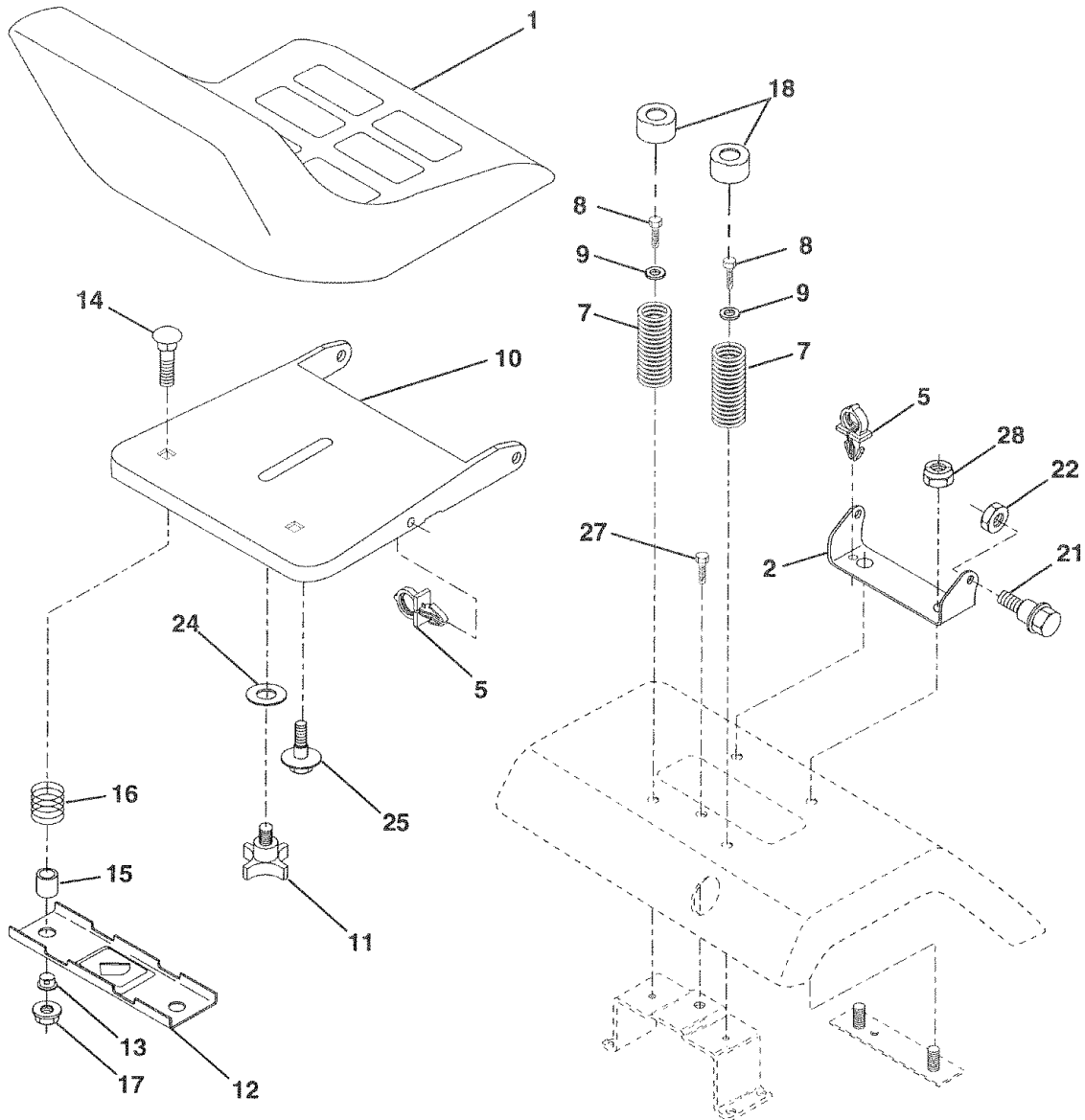

KEY NO.	PART NO.	DESCRIPTION
1	140123	Seat
2	140551	Bracket, Pivot, Seat
5	145006	Clip Push-In, Hinged
7	124181X	Spring, Seat
8	17490508	Screw Thdrol. 5/16-18 x 1/2
9	19131614	Washer 13/32 x 1 x 14 Gauge
10	140552	Pan, Seat
11	120068X	Knob, Seat
12	121246X	Bracket, Switch Mounting
13	121248X	Bushing, Snap, Nylon
14	72050411	Bolt, Carriage 1/4-20 x 1-3/8
15	134300	Spacer, Split

KEY NO.	PART NO.	DESCRIPTION
16	121250X	Spring
18	124238X	Cap, Spring, Seat
17	123976X	Nut, Flangelock 1/4 Grade 5
21	139888	Bolt, Shoulder 5/16-18 UNC
22	STD541431	Nut
24	19171912	Washer 17/32 x 1-3/16 x 12 Gauge
25	127018X	Bolt, Shoulder 5/16-18 x .62
27	17490608	Screw Thdrol. 3/8-16 x 1/2
28	STD541437	Nut

NOTE: All component dimensions given in U.S. inches
1 inch = 25.4 mm

REPAIR PARTS

TRACTOR -- MODEL NUMBER 917.252711

DECALS

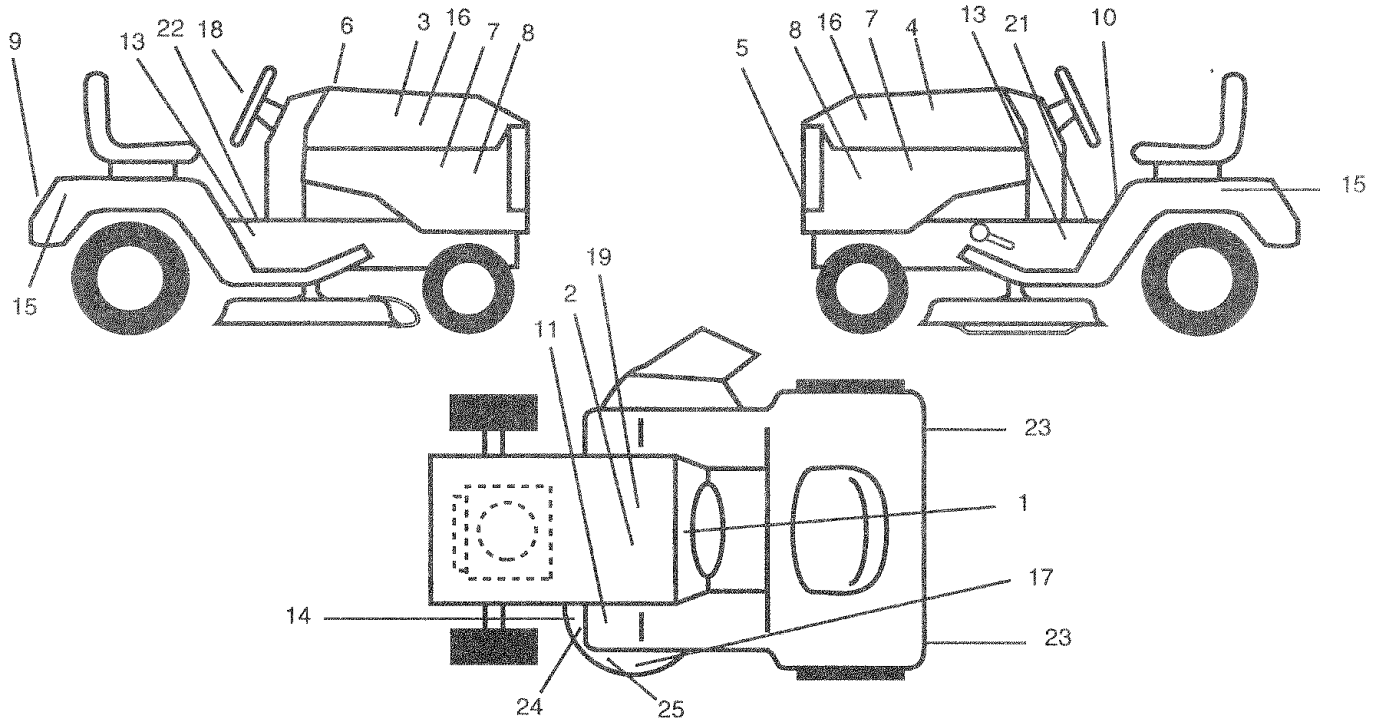

KEY NO.	PART NO.	DESCRIPTION	KEY NO.	PART NO.	DESCRIPTION
1	138955	Decal, Operating Instruction	17	133179	Decal, Mower QC System
2	145003	Decal, Battery Dngr/Psn Srs Eng	18	146710	Decal, Insert Strg
3	146705	Decal, Hood, Craftsman, RH	19	138047	Decal, Battery
4	146706	Decal, Hood, Craftsman, LH	21	140837	Decal Brake Parking Saddle
5	146708	Decal, Grille	22	142336	Decal, Sdl Cold Start Hydro Eng.
6	133644	Decal, Maintenance	23	106202X	Reflector, Taillight
7	142243	Decal, Side Panel	24	136832	Decal V-Belt SHC
8	138048	Decal, Side Panel	25	147142	Decal Deck 3 in 1
9	146709	Decal, Fender, Craftsman	--	138311	Decal, Handle Lift Height Adj.
10	137537	Decal, Caution	--	142341	Decal, Drawbar Cntrl Mvt. Hyd Lt
11	4900J	Decal, Clutch/Brake	--	137318	Decal, Refl HL YT/GT 1-pc Sears
13	147138	Decal, Chassis 42"	--	137319	Decal, Refl HL YT/GT 1-pc Sears
14	146046	Decal, V-Belt Schematic	--	145245	Pad Ftrst
15	146712	Decal, Fender Hydro	--	145247	Fastener Pop-In Footrest
16	147137	Decal Ins. Hood	--	148356	Manual, Owner's (Eng)
			--	148357	Manual, Owners (Span)

WHEELS & TIRES

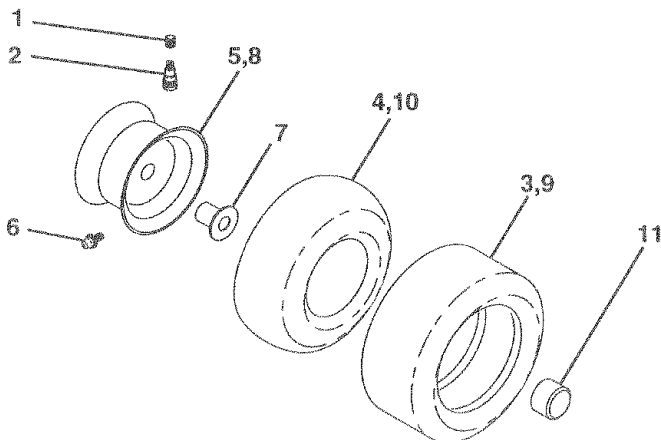

KEY NO.	PART NO.	DESCRIPTION
1	59192	Cap, Valve, Tire
2	65139	Stem, Valve
3	106222X	Tire, Front
4	59904	Tube, Front (Service Item Only)
5	106732X427	Rim Assembly, Front
6	278H	Fitting, Grease (Front Wheel Only)
7	9040H	Bearing, Flange (Front Wheel Only)
8	106108X427	Rim Assembly, Rear
9	122082X	Tire, Rear
10	7152J	Tube, Rear (Service Item Only)
11	104757X	Cap, Axle
--	144334	Sealant, Tire (10 oz. Tube)

NOTE: All component dimensions given in U.S. inches
1 inch = 25.4 mm

REPAIR PARTS

TRACTOR - - MODEL NUMBER 917.252711

MOWER LIFT

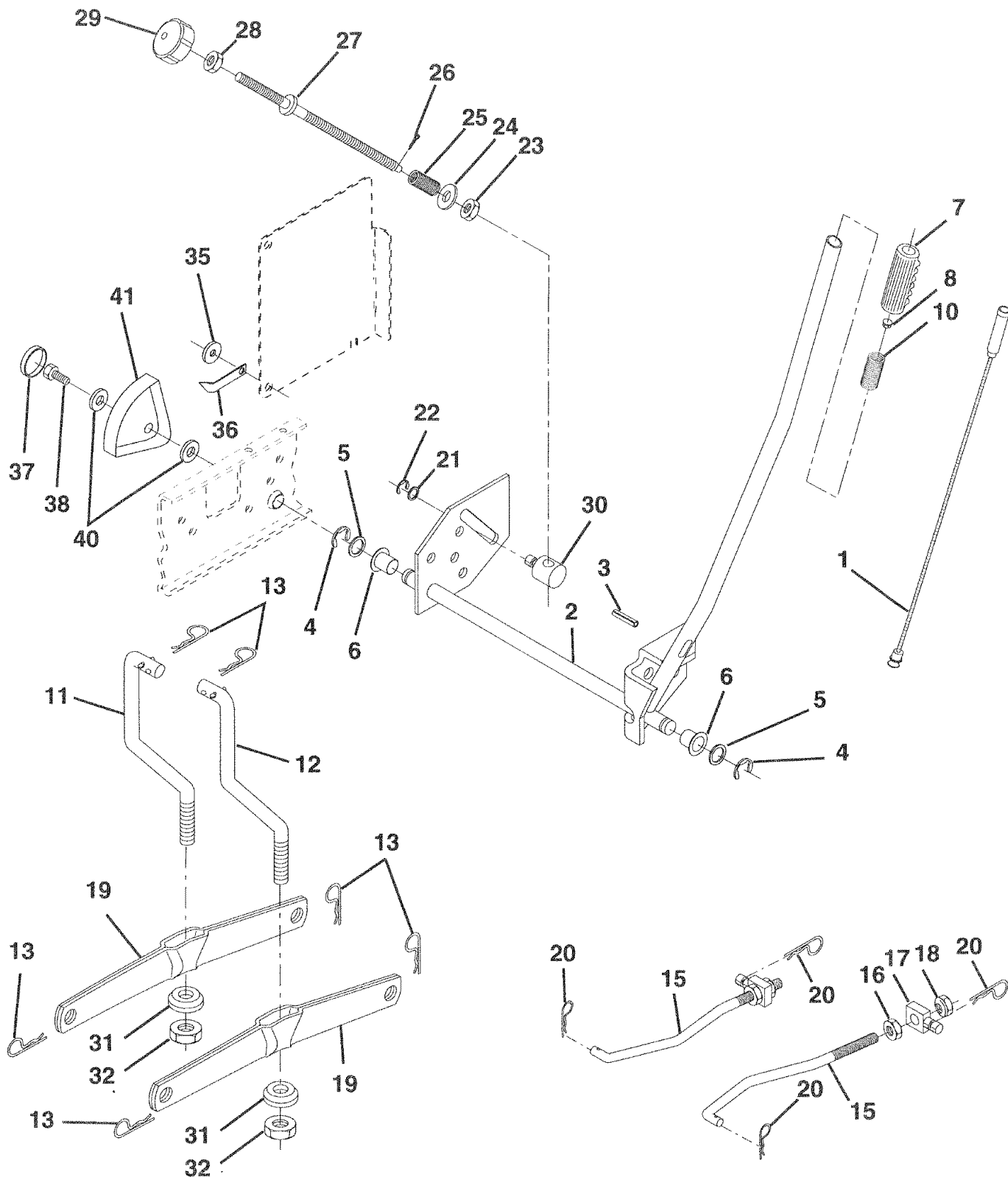

REPAIR PARTS

TRACTOR - - MODEL NUMBER 917.252711

MOWER LIFT

KEY NO.	PART NO.	DESCRIPTION
1	136971	Wire Asm., Inner w/plunger
2	136968	Shaft Asm Lift
3	138284	Pin Groove
4	12000002	E Ring #5133-62
5	19211621	Washer 21/32 X 1 X 21 Ga
6	120183X	Bearing Nylon
7	125631X	Grip Handle Fluted
8	122365X	Button, Plunger
10	122512X	Spring Cprsn
11	139865	Link Lift Lh Fixed Length
12	139866	Link Lift Rh Fixed Length
13	4939M	Retainer Spring
15	127218	Link Front
16	73350800	Nut Jam Hex 1/2-13 Unc
17	130171	Trunnion Blk Zinc
18	73800800	Nut Lock W/Wsh 1/2-13 Unc
19	139868	Arm Suspension Rear
20	3146R	Spring Retainer
21	19151216	Washer 15/32 X 3/4 X 16 Ga
22	12000037	Ring Klip #T5304-37
23	110807X	Nut Special
24	19131016	Washer 13/32 X 5/8 X 16 Ga
25	137150	Spring
26	76020308	Pin Cotter 3/32 x 1/2
27	137167	Rod Adjust Lift
28	73350600	Nut Hex Jam 3/8-16 Unc
29	138057	Knob Infinite 3/8-16 Unc Black
30	110810X	Trunnion Dp Stop Dbl Thds Plt
31	140302	Bearing Pvt. Lift Spherical
32	73540600	Nut Crownlock 3/8-24
35	120529X	Washer, Nylon .44 x .75 x .032
36	123933X505	Pointer, Height Indicator
37	123935X	Plug, Hole
38	17490512	Scr-Hx Wash Thdrol 5/16-18 x 3/4 Tyt
40	19112410	Washer 11/32 x 1-1/2 x 10 Gauge
41	123934X	Scale, Height Indicator

NOTE: All component dimensions given in U.S. inches
1 inch = 25.4 mm

REPAIR PARTS

TRACTOR - - MODEL NUMBER 917.252711

MOWER DECK

KEY NO.	PART NO.	DESCRIPTION	KEY NO.	PART NO.	DESCRIPTION
1	144393	Mower Deck Assembly, 42"	38	72110618	Bolt RDHD SWNK 3/8-16 x 2-1/4
2	STD533107	Bolt	40	STD541437	Nut
3	138017	Bracket Asm Fr. Sway Bar	44	140088	Guard, Mandrel, LH
4	138440	Bracket Asm Deck 42" Sway Bar	46	137729	Screw Thd. Roll 1/4-20 x 5/8
5	STD624008	Retainer Spring	54	133943	Washer, Hardened
6	130832	Arm, Suspension, Rear	55	140084	Arm, Idler
8	850857	Bolt 3/8-24 x 1.25 Grade 8	56	122052X	Spacer, Retainer
9	STD551137	Washer, Lock	59	141043	Guard Tuv Idler
10	140296	Washer, Hardened	61	131950	Spring Ext. Electric CL
11	134149	Blade, Mulching, 42" Mower Deck	68	144200	V-Belt, 42" Mower
12	129895	Bearing, Ball	83	120958X	Washer Sintered
13	137645	Shaft Assembly, Mandrel, Vented (Includes Key Number 12)	84	144394	Keeper, Belt Idler Fixed
14	128774	Housing, Mandrel, Vented	85	72140620	Bolt, Carriage 3/8-16 x 2-1/2 Gr. 5
15	110485X	Bearing, Ball, Mandrel	101	136420	Mulcher Cover
16	140329	Stripper, Vented Mower Deck	102	71161010	Screw
17	132823	Spacer Spring Step Idler	103	19061216	Washer #10
18	72140505	Bolt, Carriage 5/16-18 x 5/8	104	STD551110	Washer, Lock
19	132827	Bolt, Shoulder	105	130758	Latch Assembly, Bagger
20	136888	Baffle, Vortex	106	2029J	Nut, Weld
21	STD541431	Nut	111	140353	Bracket, Gauge, Wheel LH
22	134753	Stiffener Bracket	112	132262	Bracket, Gauge, Wheel RH
23	131267	Bracket, Deflector	113	17490512	Screw Thdrol 5/16-18 x 3/4 Ty.T
24	105304X	Cap, Sleeve	114	73510500	Nut, Keps 5/16 - 18 UNC
25	123713X	Spring, Torsion, Deflector	115	72110504	Bolt, Carriage 5/16 UNC x 1/2
26	110452X	Nut, Push	116	137644	Bolt, Shoulder
27	130968	Shield, Deflector	117	133957	Wheel, Gauge, Donut
28	19111016	Washer 11/32 x 5/8 x 16 Gauge	118	73930600	Nut, Locking 3/8 - 16
29	131491	Rod, Hinge	119	19121414	Washer 3/8 x 7/8 x 14 Ga.
30	138776	Screw Thdrol. Hex Head Zinc Mower	121	143723	Bracket Extruded Gauge Wheel
31	129963	Washer, Spacer	125	76020816	Pin Cotter 1/4 x 1 Plated
32	129861	Pulley, Mandrel	--	130794	Mandrel Assembly (Includes Key Numbers 8-10, 12-15, 31 and 33))
33	137266	Nut, Toplock Flanged	--	145452	Mower Deck, Complete (Std Deck - order mulching and gauge wheel components separately - key nos. 101 thru 106 and 111 thru 121)
34	72110622	Bolt			
35	133835	Fastner, Christmas Tree			
36	131494	Pulley, Idler, Flat			
37	STD551037	Washer 13/32 x 13/16 x 16 Gauge			

NOTE: All component dimensions given in U.S. inches
1 inch = 25.4 mm

REPAIR PARTS

TRACTOR - - MODEL NUMBER 917.252711

HYDRO GEAR TRANSAXLE - MODEL NUMBER 310-0750

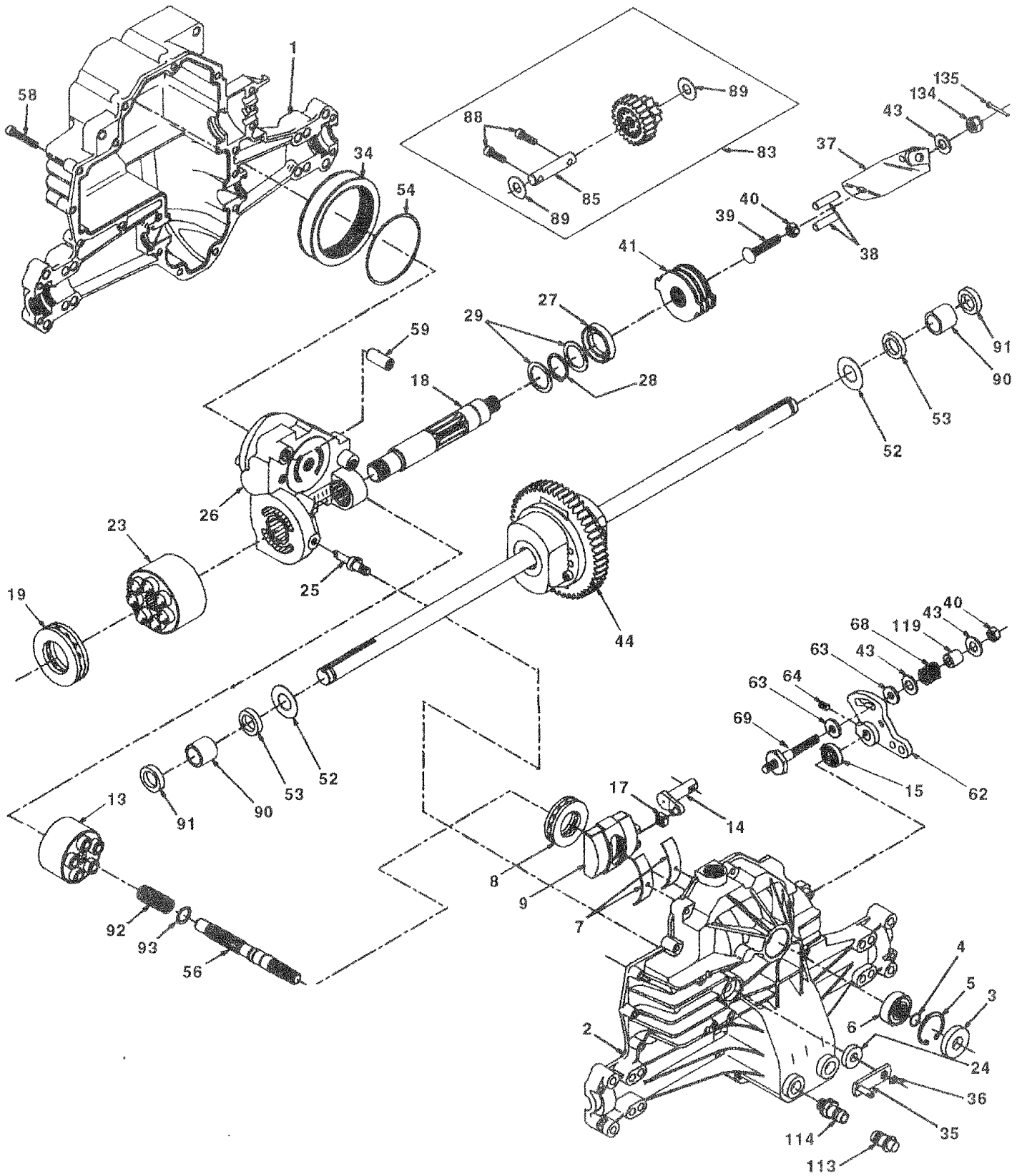

REPAIR PARTS

TRACTOR - - MODEL NUMBER 917.252711

HYDRO GEAR TRANSAXLE - MODEL NUMBER 310-0750

KEY PART NO. NO.	DESCRIPTION	KEY PART NO. NO.	DESCRIPTION
1 142930	Housing, Lower	43 142884	Washer 7/16 x 7/8 x .060
2 142931	Assembly, Upper Housing	44 142959	Differential Assembly
3 142932	Seal, Lip	52 142960	Washer 3/4 x 1.5 x .03
4 142928	Ring, Wire Retaining	53 142961	Seal .75 x 1.25 x .250
5 142933	Ring, Retaining	54 142962	O-Ring .103 x 2.987 ID
6 142934	Bearing, Shaft Ball	56 142963	Shaft, Input
7 142935	Bearing, Cradle	58 142964	Bolt 1/4-20 x 1.38
8 142936	Bearing, Thrust 30 x 52 x 13	59 142965	Pin .5 OD x .43 ID x .750
9 142937	Swashplate, Variable	62 142966	Arm, Control
13 142938	Block, Cylinder Assembly	63 142967	Puck, Dampener
14 142939	Arm, Trunnion	64 142920	Set Screw
15 142940	Seal, Lip	68 142969	Spring
17 142941	Guide, Slot	69 144610	Stud 5/16-24
18 142942	Shaft, Motor	83 142971	Jack Shaft Assembly
19 142943	Bearing, Thrust 42 x 68 x 16	85 142972	Jack Shaft
23 142944	Block, Cylinder Assembly	88 142973	Capscrew
24 142945	Seal, Lip 10 x 25 x 7	89 142974	Washer
25 142946	Actuator, Bypass	90 142975	Sleeve Bearing
26 142947	Center Section Assembly Kit	91 142976	Seal, Wiper
27 142948	Seal, Lip 26 x 42 x 8	92 142977	Spring, Block
28 142949	Ring, Retaining	93 142978	Washer, Block Thrust
29 142950	Washer 26 x 35 x 1	113 142917	Cap, Vent Assembly
34 142951	Oil Filter Element	114 142918	Fitting, O-Ring Assembly
35 142952	Arm, Bypass	119 142980	Spacer
36 142953	Ring, Retaining	134 144607	Nut, Castle 5/16-24
37 142954	Arm, Actuating	135 144608	Pin, Cotter
38 142955	Pin, Actuating		
39 142956	Bolt 5/16-24 x 1-3/4		
40 142957	Locknut, Hex 5/16-24 UNJC		
41 142958	Brake Rotor/Stator Kit		

NOTE: All component dimensions given in U.S. inches
1 inch = 25.4 mm

REPAIR PARTS

TRACTOR - - MODEL NUMBER 917.252711

KOHLER ENGINE - MODEL NUMBER MV18.OS, TYPE NUMBER PS58560

AIR INTAKE

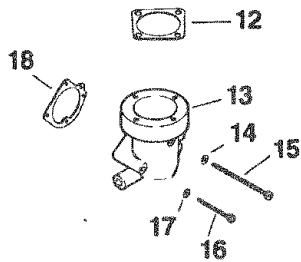
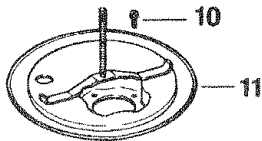
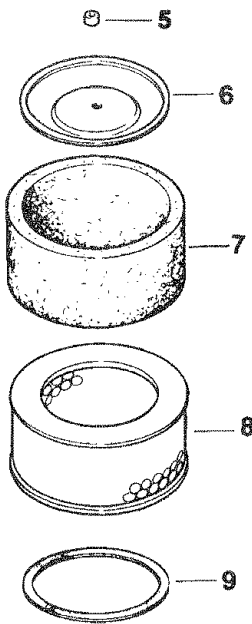
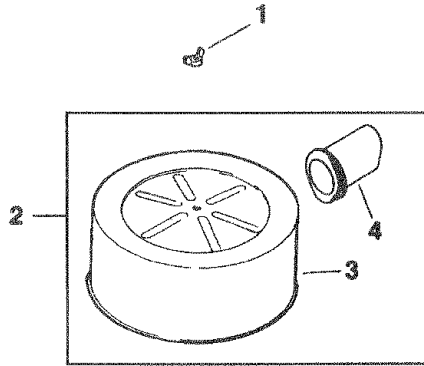

BAFFLES AND SHROUD

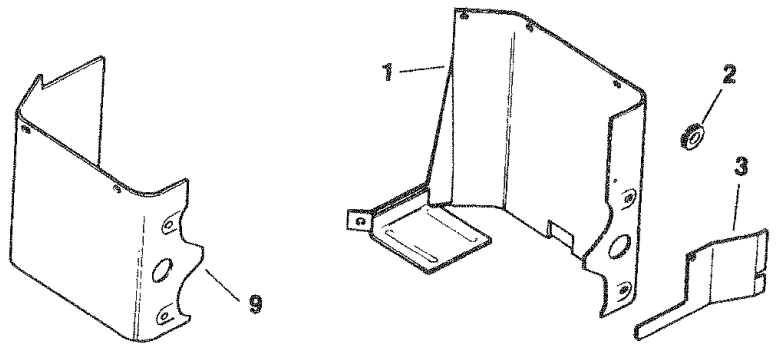
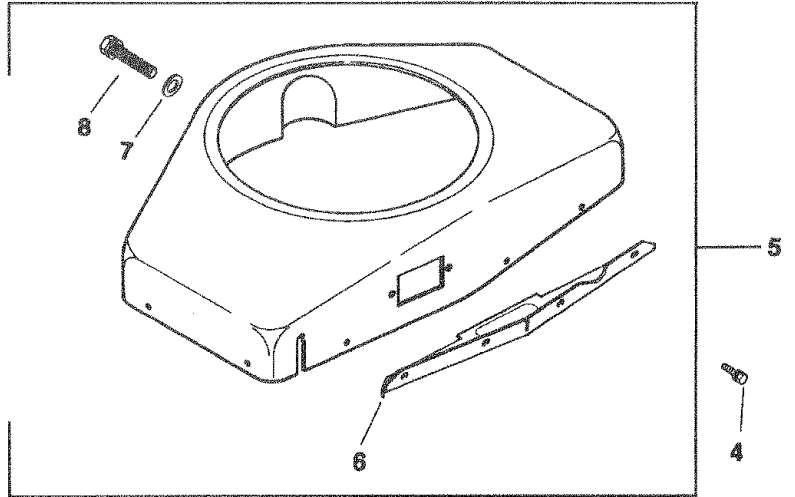

BREATHER AND VENT

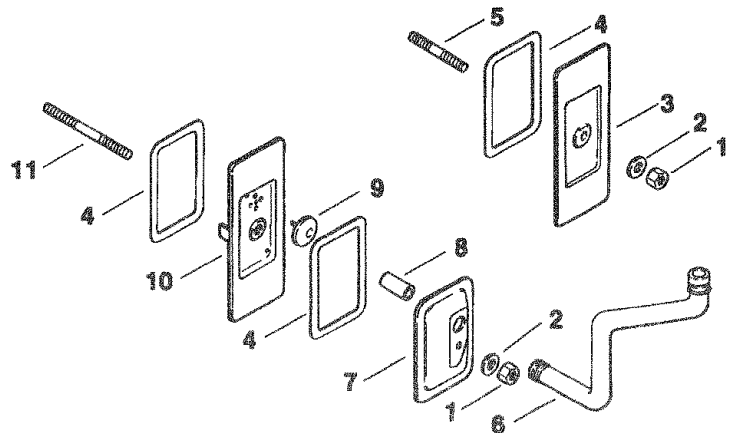

REPAIR PARTS

TRACTOR - - MODEL NUMBER 917.252711

KOHLER ENGINE - MODEL NUMBER MV18.OS, TYPE NUMBER PS58560

AIR INTAKE

KEY NO.	PART NO.	DESCRIPTION
1	X-276-7	Wing Nut 1/4-20
2	52 755 83	Kit, Cover and Tube (Includes Key Numbers 3 and 4)
3	52 096 35	Cover, Air Cleaner
4	52 123 21	Tube, Air Intake
5	231032	Seal, Element Cover
6	52 082 04	Cover, Air Cleaner Element
7	45 083 01	Pre-Cleaner
8	45 083 02	Element
9	237423	Seal, Air Cleaner Cover
10	X-67-98	Screw, Hex Washer Head #10-32 x 9/16 (4)
11	52 201 06	Base, Air Cleaner
12	277093	Gasket, Air Cleaner (2)
13	52 054 39	Elbow, Air Intake
14	X-25-79	Washer, Plain #10
15	X-50-37	Screw, Slotted Pan Head #10-32 x 2-1/4
16	X-50-57	Screw, Slotted Pan Head #10-32 x 1-3/4 (2)
17	X-22-9	Washer, Lock, Internal Tooth #10 (2)
18	25 041 06	Gasket, Air Cleaner Elbow

NOT ILLUSTRATED

--	25 113 15	Decal, Air Cleaner
--	52 113 30	Decal

BAFFLES & SHROUD

KEY NO.	PART NO.	DESCRIPTION
1	52 063 41	Baffle, #2 Cylinder Head
2	52 313 05	Grommet (2)
3	52 063 42	Baffle, Fuel Pump
4	X-67-83	Screw, Hex Washer Head 1/4-20 x 7/16 (14)
5	52 755 70	Kit, Blower Housing (Includes Key Numbers 6 thru 8)
6	52 217 01	Support, Upper Housing

7	52 468 16	Washer, Flat (2)
8	52 086 11	Screw 1/4-20 x 5/8 (6)
9	52 124 23	Baffle, #1 Cylinder Head

NOT ILLUSTRATED

--	52 113 46	Decal, Horsepower (3)
----	-----------	-----------------------

BREATHER & VENT

KEY NO.	PART NO.	DESCRIPTION
1	X-81-1	Nut, Hex 1/4-20 (2)
2	X-25-12	Washer, Plain 1/4 (2)
3	52 096 18	Cover, #2 Cylinder Valve
4	52 055 01	Gasket, Cover (3)
5	X-352-39	Stud, #2 Cylinder Valve Cover 1/4-20 x 2-1/4
6	52 326 12	Hose, Breather
7	52 096 08	Cover, #1 Upper Cylinder Valve
8	52 032 04	Seal, Breather
9	52 462 01	Valve, Umbrella
10	52 096 22	Cover, #1 Lower Cylinder Valve
11	275220	Stud, #1 Cylinder Valve Cover 1/4-20 x 3-1/4

NOTE: All component dimensions given in U.S. inches
1 inch = 25.4 mm

REPAIR PARTS

TRACTOR - - MODEL NUMBER 917.252711

KOHLER ENGINE - MODEL NUMBER MV18.OS, TYPE NUMBER PS58560

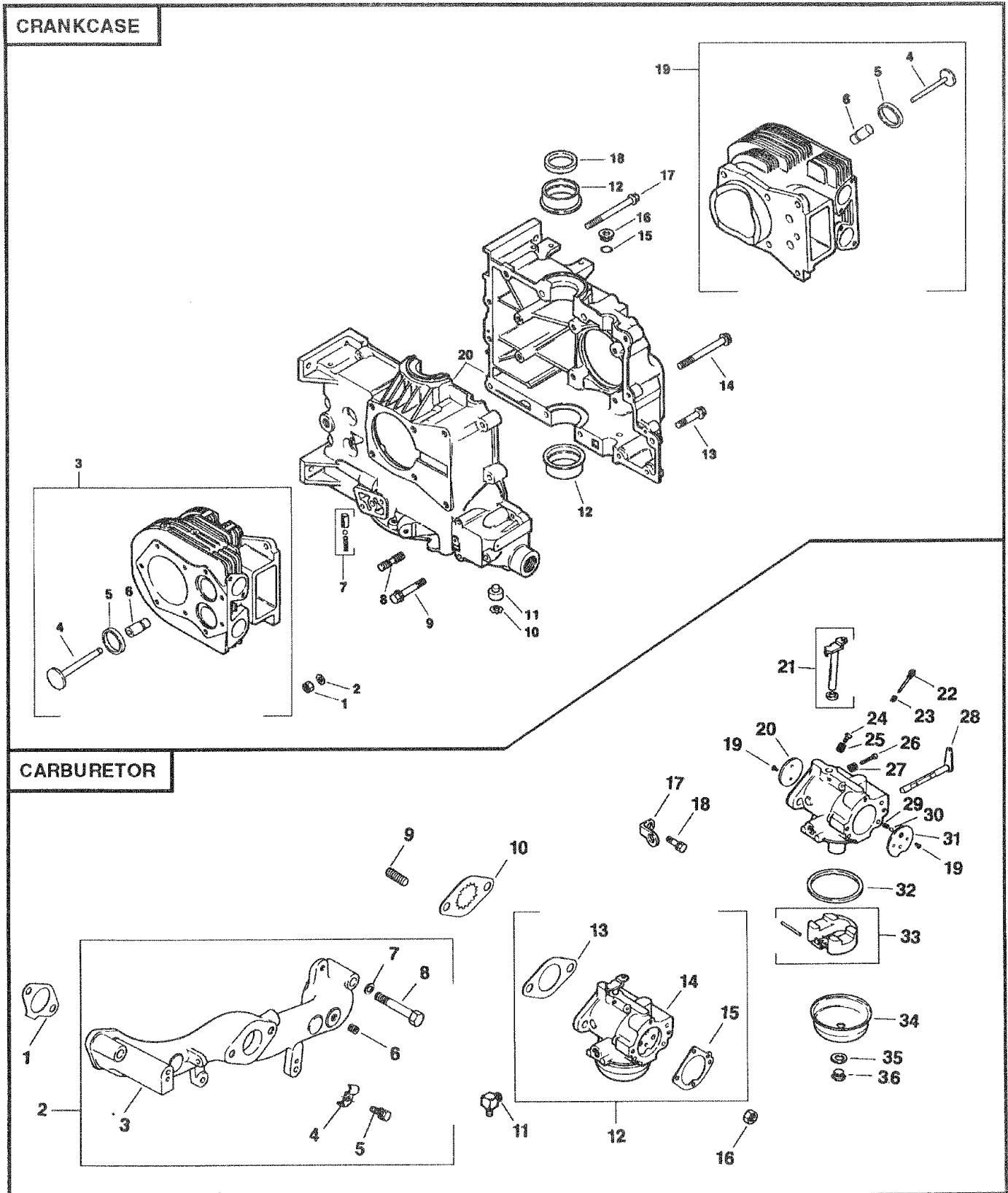

REPAIR PARTS

TRACTOR - - MODEL NUMBER 917.252711

KOHLER ENGINE - MODEL NUMBER MV18.OS, TYPE NUMBER PS58560

CRANKCASE

KEY NO.	PART NO.	DESCRIPTION
1	X-82-2	Nut, Hex 5/16-18 (12)
2	52 468 12	Washer, Flat 5/16 (12)
3	82 755 16	Kit, #1 Cylinder Barrel (Includes Key Numbers 4 thru 6)
4	52 016 05	Valve, Exhaust
5	52 031 01	Insert, Valve Seat (2)
6	52 316 06	Guide, Valve (2)
7	52 755 50	Kit, Oil Relief
8	52 072 12	Step Stud 5/16-18 x 3/4, 3/8-16 x 5/8, 2" Long (12)
9	25 086 12	Screw, Hex Flange 5/16-18 x 2 (2)
10	X-269-43	Ring, Retaining
11	52 078 05	Shaft, Governor
12	52 030 10	Bearing, Sleeve, Standard (2)
	52 030 11	Bearing, Sleeve .010" (2)
	52 030 12	Bearing, Sleeve .020" (2)
13	25 086 10	Screw, Hex Flange 5/16-18 x 1-1/2 (3)
14	25 086 13	Screw, Hex Flange 3/8-16 x 3-5/8 (2)
15	52 141 02	O-Ring
16	52 139 08	Plug
17	25 086 11	Screw, Hex Flange 5/16-18 x 3-1/2 (8)
18	52 032 10	Seal, Oil, Front
19	82 755 17	Kit, #2 Cylinder Barrel (Includes Key Numbers 4 thru 6)
20	---	Crankcase (Service with Short Block, Part Number 82 522 30)

CARBURETOR

KEY NO.	PART NO.	DESCRIPTION
1	52 041 09	Gasket, Intake (2)
2	52 755 91	Kit, Manifold (Includes Key Numbers 3 thru 8)
3	52 164 15	Manifold, Intake
4	X-21-1	Washer, Lock 5/16 (4)
5	X-6-29	Screw, Hex Cap 5/16-18 x 2 (4)
6	X-75-23	Plug, Hex, Countersunk 1/8 N.P.T.F.
7	235778	Clamp, Cable (2)
8	X-67-97	Screw, Hex Washer Head #10-24 x 3/8 (2)
9	41 072 19	Stud 5/16-18 x 1 (2)
10	52 063 40	Baffle, Carburetor
11	25 155 02	Connector, Hose
12	52 853 25	Kit, Carburetor with Gasket (Includes Key Numbers 12 thru 14)
13	271030	Gasket, Carburetor (2)
14	52 053 54	Carburetor Assembly (Information Only - Not Available Separately) (Includes Key Numbers 18 thru 35)

15	25 041 06	Gasket, Air Cleaner
16	X-77-2	Nut 5/16 (2)
17	232867	Strap, Lifting
18	X-67-62	Screw, Hex Washer Head 1/4-20 x 3/4
19	25 086 27	Screw, Throttle and Choke Plate (4)
20	25 146 03	Plate, Choke
21	52 144 24	Shaft, Throttle with Lever and Seal
22	25 368 01	Needle, Idle Fuel Adjust
23	25 089 02	Spring, Idle, Fuel
24	25 086 26	Screw, Idle Speed Adjust
25	25 089 04	Spring, Idle Speed
26	25 368 03	Needle, Main Fuel
27	25 089 02	Spring, Main Fuel
28	52 090 13	Lever, Choke
29	25 089 03	Spring, Choke, Friction
30	25 194 01	Ball, Choke, Friction
31	25 146 02	Plate, Throttle
32	25 041 04	Gasket, Bowl
33	25 757 09	Kit, Float
34	25 104 01	Bowl, Fuel
35	25 041 03	Gasket, Bowl Retainer Screw
36	25 100 05	Screw, Bowl Retainer

NOT ILLUSTRATED

--	25 757 11	Kit, Carburetor Repair
--	25 757 23	Kit, Bowl Baffle

NOTE: All component dimensions given in U.S. inches
1 inch = 25.4 mm

RPM Settings: Low Speed 1500 - 2000
 High Speed 3200 - 3400

REPAIR PARTS

TRACTOR - - MODEL NUMBER 917.252711

KOHLER ENGINE - MODEL NUMBER MV18.OS, TYPE NUMBER PS58560

CRANKSHAFT

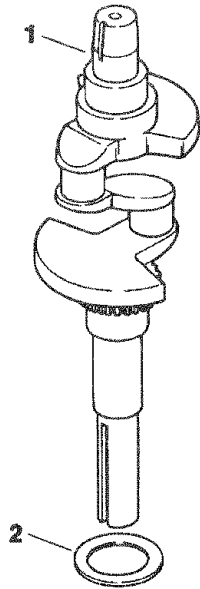

DIPSTICK

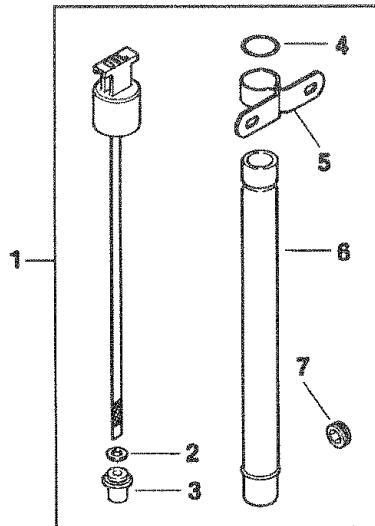

CYLINDER HEAD

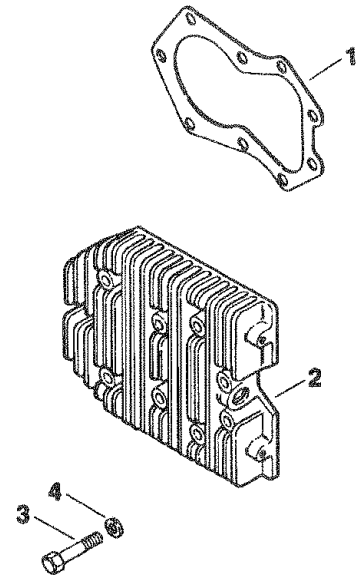

ELECTRIC STARTER

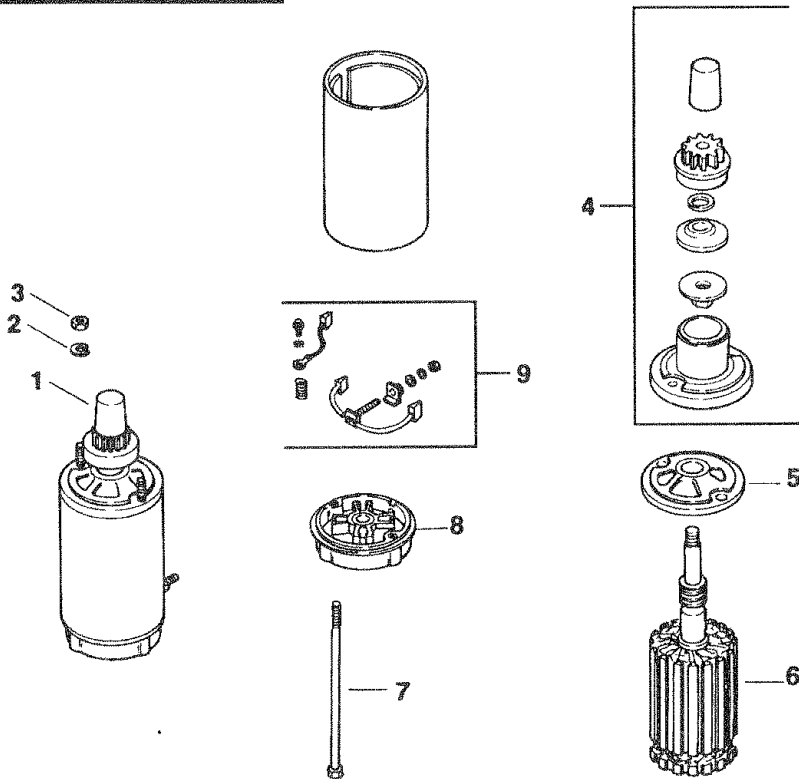

EXHAUST

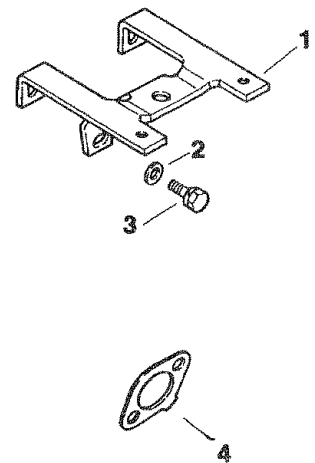

REPAIR PARTS

TRACTOR - - MODEL NUMBER 917.252711

KOHLER ENGINE - MODEL NUMBER MV18.OS, TYPE NUMBER PS58560

CRANKSHAFT

KEY PART NO.	PART NO.	DESCRIPTION
1	52 014 93	Crankshaft
2	52 468 03	Washer, Thrust .119/.122 (A.R.)
	52 468 04	Washer, Thrust .128/.131
	52 468 05	Washer, Thrust .137/.140 (A.R.)

3	52 086 11	Screw 1/4-20 x 5/8 (3)
4	52 041 14	Gasket, Exhaust (2)

NOTE: All component dimensions given in U.S. inches
1 inch = 25.4 mm

DIPSTICK

KEY PART NO.	PART NO.	DESCRIPTION
1	52 038 14	Dipstick Assembly (Includes Key Numbers 2 and 3)
2	X-25-44	Washer, Plain 5/16
3	52 032 14	Seal, Rubber
4	41 153 01	O-Ring
5	52 126 11	Bracket, Oil Tube Support
6	52 123 20	Tube, Oil Fill 11-7/8
7	47 139 01	Plug, Hex, Countersunk 3/4 N.P.T.F.

CYLINDER HEAD

KEY PART NO.	PART NO.	DESCRIPTION
1	52 041 20	Gasket, Head (2)
2	52 015 08	Cylinder Head (2)
3	220534	Washer, Plain 5/16 (18)
4	41 086 02	Screw, Hex Head 5/16-18 x 1-1/2 (18)

ELECTRIC STARTER

KEY PART NO.	PART NO.	DESCRIPTION
1	52 098 12	Starter Assembly (Includes Key Numbers 4 thru 9)
2	X-20-1	Washer, Lock 1/4 (2)
3	X-81-1	Nut, Hex 1/4-20 (2)
4	82 755 26	Kit, Drive
5	52 081 07	Cap, Drive End
6	52 170 05	Armature
7	52 211 01	Bolt, Thru (2)
8	52 227 10	Cap, Commutator End
9	82 755 28	Kit, Brush

NOT ILLUSTRATED

--	25 450 03	Tag, Caution
----	-----------	--------------

EXHAUST

KEY PART NO.	PART NO.	DESCRIPTION
1	52 126 12	Bracket
2	X-25-72	Washer, Plain (3)

SERVICE NOTES

SERVICE NOTES

SERVICE NOTES

SUGGESTED GUIDE FOR SIGHTING SLOPES FOR SAFE OPERATION

59

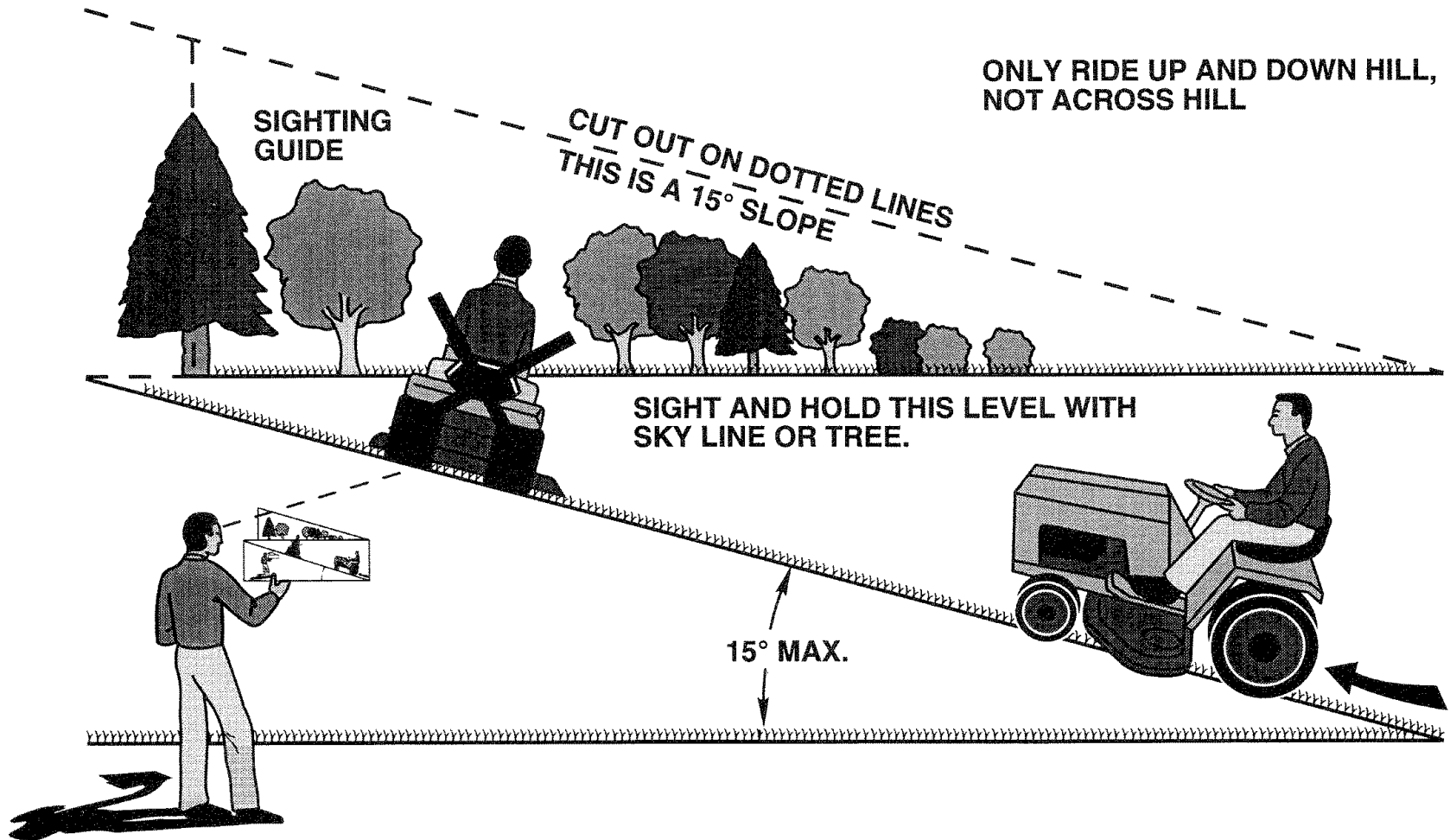

 Operate your Tractor up and down the face of slopes (not greater than 15°), never across the face. Make turns gradually to prevent tipping or loss of control. Exercise extreme caution when changing direction on slopes.

SEARS

**OWNER'S
MANUAL**

**MODEL NO.
917.252711**

**IF YOU NEED
REPAIR SERVICE
OR PARTS:**

FOR REPAIR SERVICE, CALL
THIS TOLL FREE NUMBER:

1-800-4-REPAIR
(1-800-473-7247)

FOR REPLACEMENT PARTS
INFORMATION AND
ORDERING, CALL THIS
TOLL FREE NUMBER:

1-800-FON-PART
(1-800-366-7278)

FOR CONSUMER ASSISTANCE
HOT LINE, CALL THIS
TOLL FREE NUMBER:

1-800-659-5917

CRAFTSMAN®

**18 HP TWIN CYLINDER
ELECTRIC START
3 in One Convertible
42" MOWER
AUTOMATIC (HYDROSTATIC)
DRIVE
LAWN TRACTOR**

Each tractor has its own model number. Each engine has its own model number.

The model number for your tractor will be found on the model plate located under the seat.

The model number for your engine will be found on the blower housing of the engine.

All parts listed herein may be ordered from any Sears, Roebuck and Co. Service Center/Department and most Retail Stores.

**WHEN ORDERING REPAIR PARTS, ALWAYS GIVE THE
FOLLOWING INFORMATION:**

- **PRODUCT - TRACTOR**
- **MODEL NUMBER - 917.252711**
- **ENGINE MODEL NO. - MV18S-58560**
- **PART NUMBER**
- **PART DESCRIPTION**

Your Sears merchandise has added value when you consider Sears has service units nationwide staffed with Sears trained technicians... professional technicians specifically trained to insure that we meet our pledge to you, we service what we sell.