

SEARS

CRAFTSMAN®

MODEL NUMBER 917.376340 OWNER'S MANUAL

EZ³

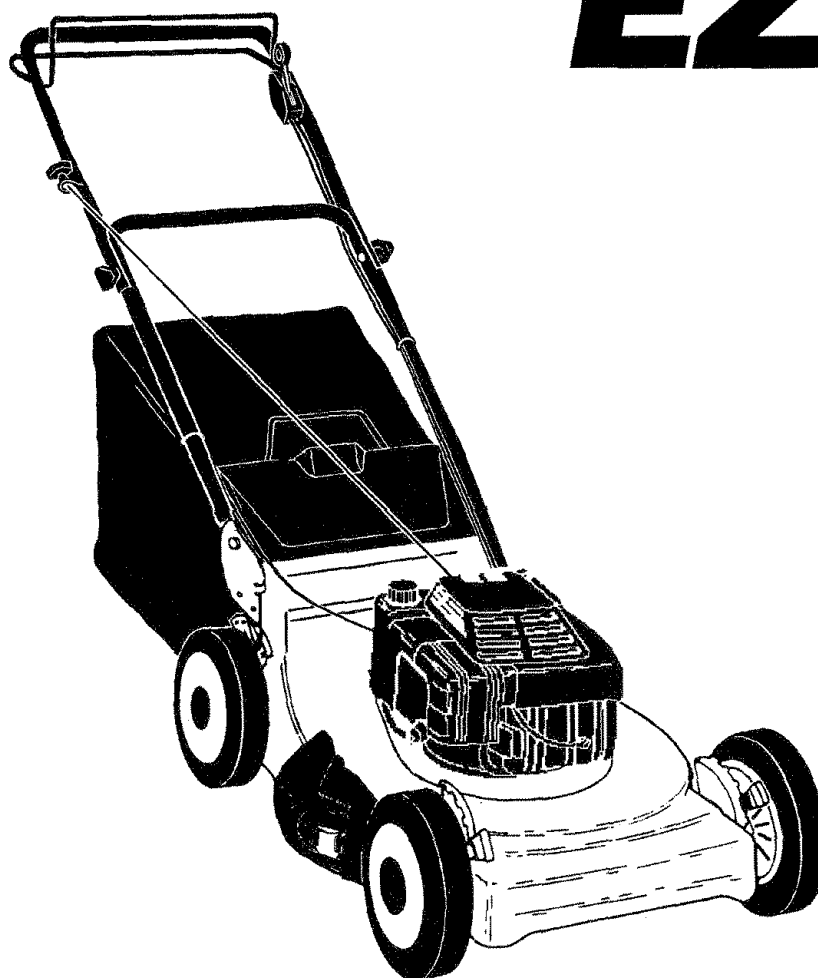

- **Assembly**
- **Operation**
- **Customer Responsibilities**
- **Service**
- **Adjustments**
- **Repair Parts**

Caution:
Read and Follow
all Safety Rules
and Instructions
Before Operating
This Equipment

153367 12.19.95 ks

Printed in U.S.A.

Sears, Roebuck and Co., Hoffman Estates, IL 60179 U.S.A.



SAFETY RULES



Safe Operation Practices for Walk-Behind Mowers

IMPORTANT: THIS CUTTING MACHINE IS CAPABLE OF AMPUTATING HANDS AND FEET AND THROWING OBJECTS. FAILURE TO OBSERVE THE FOLLOWING SAFETY INSTRUCTIONS COULD RESULT IN SERIOUS INJURY OR DEATH.

SAFETY STANDARDS REQUIRE OPERATOR PRESENCE CONTROLS TO MINIMIZE THE RISK OF INJURY. YOUR UNIT IS EQUIPPED WITH SUCH CONTROLS. DO NOT ATTEMPT TO DEFEAT THE FUNCTION OF THE OPERATOR PRESENCE CONTROLS UNDER ANY CIRCUMSTANCES.

TRAINING:

- Read this operator's manual carefully. Become familiar with the controls and know how to operate your mower properly. Learn how to quickly stop mower.
- Do not allow children to use your mower. Never allow adults to use mower without proper instructions.
- Keep the area of operation clear of all persons, especially small children and pets.
- Use mower only as the manufacturer intended and as described in this manual.
- Do not operate mower if it has been dropped or damaged in any manner. Always have damage repaired before using your mower.
- Do not use accessory attachments that are not recommended by the manufacturer. Use of such attachments may be hazardous.
- The blade turns when the engine is running.

- Do not continue to run your mower if you hit a foreign object. Follow the procedure outlined above, then repair any damage before restarting and operating your mower.
- Do not change the governor settings or overspeed the engine. Engine damage or personal injury may result.
- Do not operate your mower if it vibrates abnormally. Excessive vibration is an indication of damage; stop the engine, safely check for the cause of vibration and repair as required.
- Do not run the engine indoors. Exhaust fumes are dangerous.
- Never cut grass by pulling the mower towards you. Mow across the face of slopes, never up and down or you might lose your footing. Do not mow excessively steep slopes. Use caution when operating the mower on uneven terrain or when changing directions - maintain good footing.
- Never operate your mower without proper guards, plates, grass catcher or other safety devices in place.

PREPARATION:

- Always thoroughly check the area to be mowed and clear it of all stones, sticks, wires, bones, and other foreign objects. These objects will be thrown by the blade and can cause severe injury.
- Always wear safety glasses or eye shields when starting and while using your mower.
- Dress properly. Do not operate mower when barefoot or wearing open sandals. Wear only solid shoes with good traction when mowing.
- Check fuel tank before starting engine. Do not fill gas tank indoors, when the engine is running or when the engine is hot. Allow the engine to cool for several minutes before filling the gas tank. Clean off any spilled gasoline before starting the engine.
- Always make wheel height adjustments before starting your mower. Never attempt to do this while the engine is running.
- Mow only in daylight or good artificial light.

MAINTENANCE AND STORAGE:

- Check the blade and the engine mounting bolts often to be sure they are tightened properly.
- Check all bolts, nuts and screws at frequent intervals for proper tightness to be sure mower is in safe working condition.
- Keep all safety devices in place and working.
- To reduce fire hazard, keep the engine free of grass, leaves or excessive grease and oil.
- Check grass catcher often for deterioration and wear and replace worn bags. Use only replacement bags that are recommended by and comply with specifications of the manufacturer of your mower.
- Always keep a sharp blade on your mower.
- Allow engine to cool before storing in any enclosure.
- Never store mower with fuel in the tank inside a building where fumes may reach an open flame or an ignition source such as a hot water heater, space heater, clothes dryer, etc.

OPERATION:

- Keep your eyes and mind on your mower and the area being cut. Do not let other interests distract you.
- Do not mow wet or slippery grass. Never run while operating your mower. Always be sure of your footing - keep a firm hold on the handles and walk.
- Do not put hands or feet near or under rotating parts. Keep clear of the discharge opening at all times.
- Always stop the engine whenever you leave or are not using your mower, or before crossing driveways, walks, roads, and any gravel-covered areas.
- Never direct discharge of material toward bystanders nor allow anyone near the mower while you are operating it.
- Before cleaning, inspecting, or repairing your mower, stop the engine and make absolutely sure the blade and all moving parts have stopped. Then disconnect the spark plug wire and keep it away from the spark plug to prevent accidental starting.



Look for this symbol to point out important safety precautions. It means **CAUTION!!! BECOME ALERT!!! YOUR SAFETY IS INVOLVED.**



CAUTION: Always disconnect spark plug wire and place wire where it cannot contact spark plug in order to prevent accidental starting when setting up, transporting, adjusting or making repairs.



The engine exhaust from this product contains chemicals known to the State of California to cause cancer, birth defects, or other reproductive harm.

CONGRATULATIONS on your purchase of a Sears Lawn Mower. It has been designed, engineered and manufactured to give you the best possible dependability and performance.

Should you experience any problem you cannot easily remedy, please contact your nearest Sears Authorized Service Center/Department. We have competent, well-trained technicians and the proper tools to service or repair this lawn mower.

Please read and retain this manual. The instructions will enable you to assemble and maintain your lawn mower properly. Always observe the "SAFETY RULES".

MODEL
NUMBER 917.376340

SERIAL
NUMBER _____

DATE OF PURCHASE _____

THE MODEL AND SERIAL NUMBERS WILL BE FOUND ON A DECAL ATTACHED TO THE REAR OF THE LAWN MOWER HOUSING.

YOU SHOULD RECORD BOTH SERIAL NUMBER AND DATE OF PURCHASE AND KEEP IN A SAFE PLACE FOR FUTURE REFERENCE.

PRODUCT SPECIFICATIONS

HORSEPOWER:	6.5
DISPLACEMENT:	12.56 CU. IN.
GASOLINE CAPACITY AND TYPE:	1.5 QUART UNLEADED REGULAR
OIL TYPE (API-SF/SG):	SAE 30 (ABOVE 32°F) SAE 5W-30 (below 32°F)
OIL CAPACITY:	27 OZ.
SPARK PLUG: (GAP: .030")	CHAMPION J19LM, RJ19LM STD361458
VALVE CLEARANCE:	INTAKE: .008" EXHAUST: .008"
SOLID STATE IGNITION AIR GAP:	.0125 in.
BLADE BOLT TORQUE:	35-40 FT. LBS.

MAINTENANCE AGREEMENT

A Sears Maintenance Agreement is available on this product. Contact your nearest Sears store for details.

CUSTOMER RESPONSIBILITIES

- Read and observe the safety rules.
- Follow a regular schedule in maintaining, caring for and using your lawn mower.
- Follow the instructions under "Customer Responsibilities" and "Storage" sections of this owner's manual.

LIMITED TWO YEAR WARRANTY ON CRAFTSMAN POWER MOWER

For two years from date of purchase, when this Craftsman Lawn Mower is maintained, lubricated, and tuned up according to the operating and maintenance instructions in the owner's manual, Sears will repair free of charge any defect in material or workmanship.

If this Craftsman Lawn Mower is used for commercial or rental purposes, this warranty applies for only 90 days from the date of purchase.

This Warranty does not cover:

- Expendable items which become worn during normal use, such as rotary mower blades, blade adapters, belts, air cleaners and spark plug.
- Repairs necessary because of operator abuse or negligence, including bent crankshafts and the failure to maintain the equipment according to the instructions contained in the owner's manual.

WARRANTY SERVICE IS AVAILABLE BY RETURNING THE CRAFTSMAN POWER MOWER TO THE NEAREST SEARS SERVICE CENTER/DEPARTMENT IN THE UNITED STATES. THIS WARRANTY APPLIES ONLY WHILE THIS PRODUCT IS IN USE IN THE UNITED STATES.



This Warranty gives you specific legal rights, and you may also have other rights which vary from state to state.

SEARS, ROEBUCK AND CO., D/731CR-W SEARS TOWER, CHICAGO, IL 60684

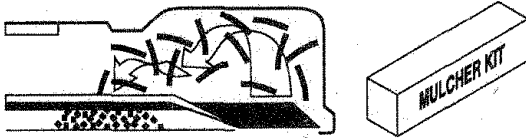

LAWN MOWER ACCESSORIES

These accessories were available when this lawn mower was produced. They are also available at most Sears retail outlets and service centers. Most Sears stores can also order repair parts for you, when you provide the model number of your lawn mower. Some of these accessories may not apply to your lawn mower.

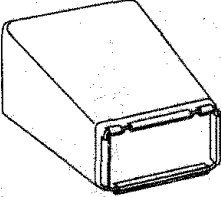
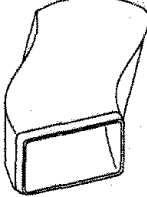
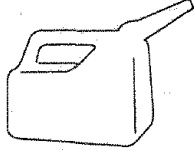
LAWN MOWER PERFORMANCE

 <p>CLIPPING DEFLECTOR FOR REAR DISCHARGE LAWN MOWERS</p>	 <p>MULCHER KITS</p>	 <p>STABILIZER</p>
 <p>GRASS CATCHERS FOR REAR DISCHARGE LAWN MOWERS</p>	 <p>GRASS CATCHERS FOR SIDE DISCHARGE LAWN MOWERS</p>	 <p>GAS CANS</p>

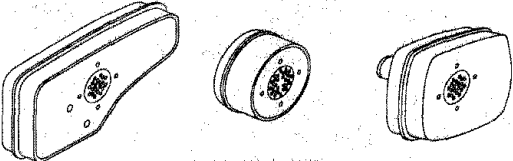
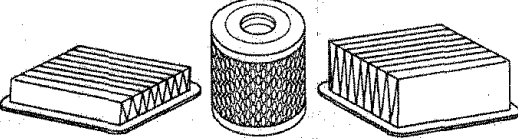
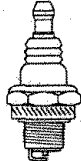
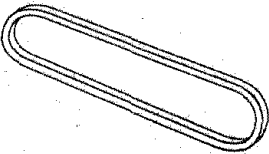
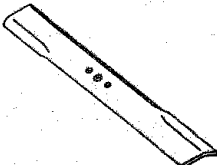
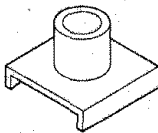
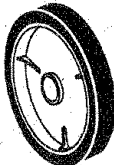
LAWN MOWER MAINTENANCE

 <p>MUFFLERS</p>		 <p>AIR FILTERS</p>		 <p>SPARK PLUGS</p>
 <p>BELTS</p>	 <p>BLADES</p>	 <p>BLADE ADAPTERS</p>	 <p>WHEELS</p>	 <p>ENGINE OIL</p>

ASSEMBLY

Read these instructions and this manual in its entirety before you attempt to assemble or operate your new lawn mower. Your new lawn mower has been assembled at the factory with the exception of those parts left unassembled for shipping purposes. To ensure safe and proper operation of your lawn mower, all parts and hardware you assemble must be tightened securely. Use the correct tools as necessary to ensure proper tightness. All parts such as nuts, washers, bolts, etc., necessary to complete the assembly have been placed in the parts bag.

TO REMOVE LAWN MOWER FROM CARTON

- Remove loose parts included with mower.
- Cut down two end corners of carton and lay end panel down flat.
- Remove all packing materials except padding between upper and lower handle and padding holding operator presence control bar to upper handle.
- Roll lawn mower out of carton and check carton thoroughly for additional loose parts.

HOW TO SET UP YOUR LAWN MOWER

TO UNFOLD HANDLE (See Figs. 1 & 2)

IMPORTANT: UNFOLD HANDLE CAREFULLY SO AS NOT TO PINCH OR DAMAGE CONTROL CABLES.

- Raise lower handle section to operating position and squeeze the bottom ends of lower handle towards each other until the pin in handle can be inserted into one of the three height adjustment holes.
- Raise upper handle section to operating position, remove protective padding and tighten handle knobs securely.
- Remove any packing material from around control bar.
- Your handles may be adjusted for your mowing comfort. Refer to Service and Adjustments section of this manual.

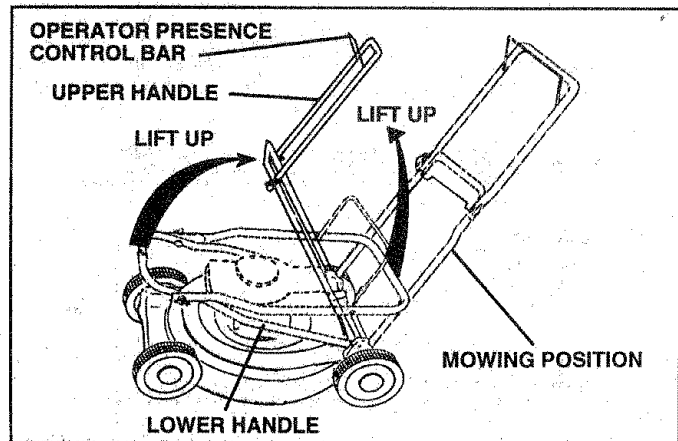

FIG. 1

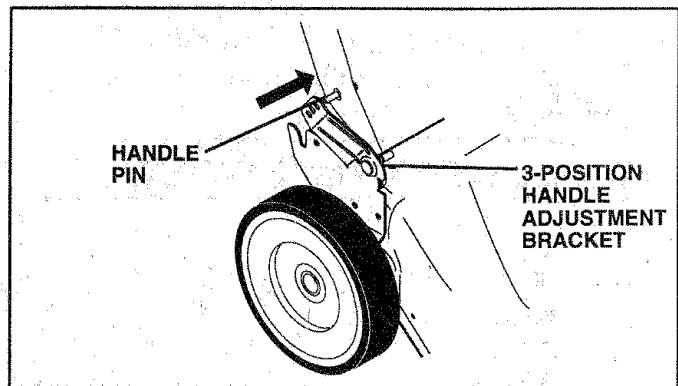

FIG. 2

ASSEMBLY

TO CONVERT MOWER

Your lawn mower was shipped ready to be used as a mulcher. To convert to bagging or discharging:

REAR BAGGING (See Fig. 3A) -

- Open rear door and remove mulcher plug. Store mulcher plug in a safe place.
- You can now install grass catcher.
- To convert to mulching or discharging operation, install mulcher plug into rear discharge opening of mower, making sure all tabs are seated properly.

SIDE DISCHARGING (See Fig. 3B) -

- Mulcher plug must be installed into rear discharge opening of mower (see above instructions).
- Unlock closed discharge guard by lifting latch and allow guard to swing open to discharging position.
- Mower is now ready for discharging operation.
- To convert to mulching or bagging operation, discharge guard must be closed and locked securely.

SIMPLE STEPS TO REMEMBER

WHEN CONVERTING YOUR LAWN MOWER

FOR MULCHING -

- Rear mulcher plug installed.
- Side discharge guard closed and locked securely.

FOR REAR BAGGING -

- Rear mulcher plug removed.
- Grass catcher installed.
- Side discharge guard closed and locked securely.

FOR SIDE DISCHARGING -

- Rear mulcher plug installed.
- Side discharge guard unlocked and open.



CAUTION: Do not run your lawn mower without rear mulcher plug in place or approved grass catcher in place. Never attempt to operate the lawn mower with the rear door removed or propped open.

TO ASSEMBLE & ATTACH GRASS CATCHER (See Figs. 4 & 5)

- Put grass catcher frame into grass bag with rigid part of bag on the bottom. Make sure the frame handle is outside of the bag top.
- Slip vinyl bindings over frame.

NOTE: If vinyl bindings are too stiff, hold them in warm water for a few minutes. If bag gets wet, let it dry before using.

- Lift the rear door on the mower housing and place the grass catcher frame side hooks onto handle bracket hooks.
- The grass catcher is secured to the lawn mower housing when the rear door is lowered onto the grass catcher frame.

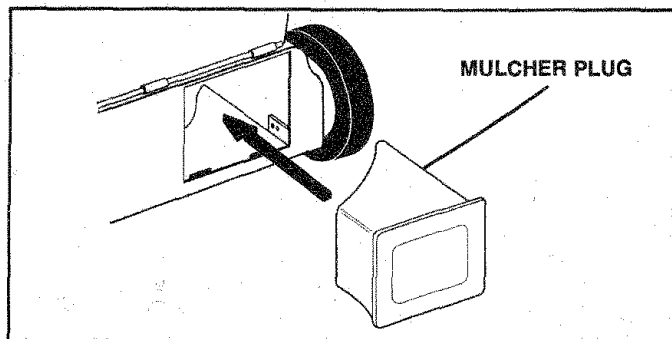

FIG. 3A

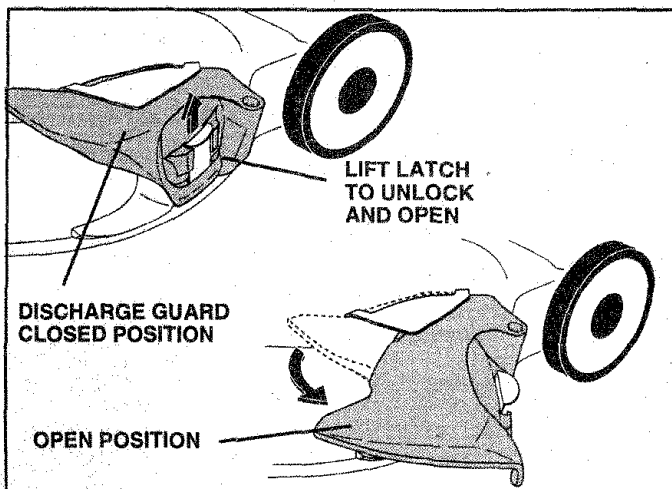

FIG. 3B

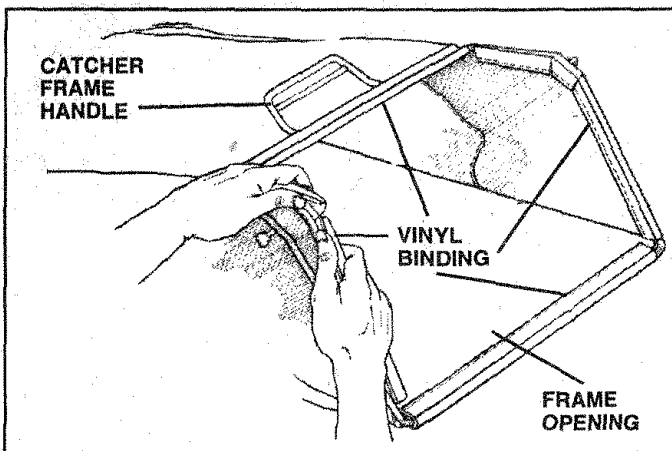

FIG. 4

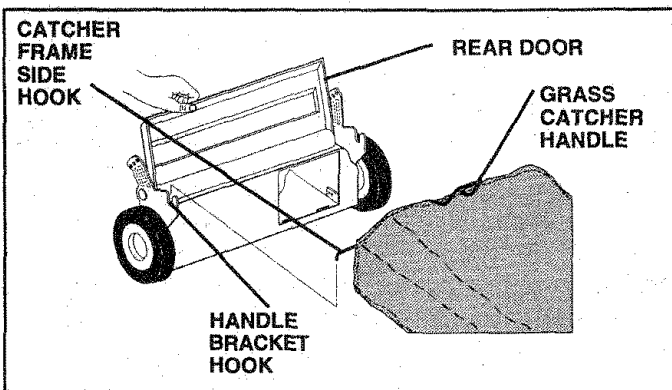

FIG. 5

OPERATION

KNOW YOUR LAWN MOWER

READ THIS OWNER'S MANUAL AND SAFETY RULES BEFORE OPERATING YOUR LAWN MOWER. Compare the illustrations with your lawn mower to familiarize yourself with the location of various controls and adjustments. Save this manual for future reference.

These symbols may appear on your lawn mower or in literature supplied with the product. Learn and understand their meaning.

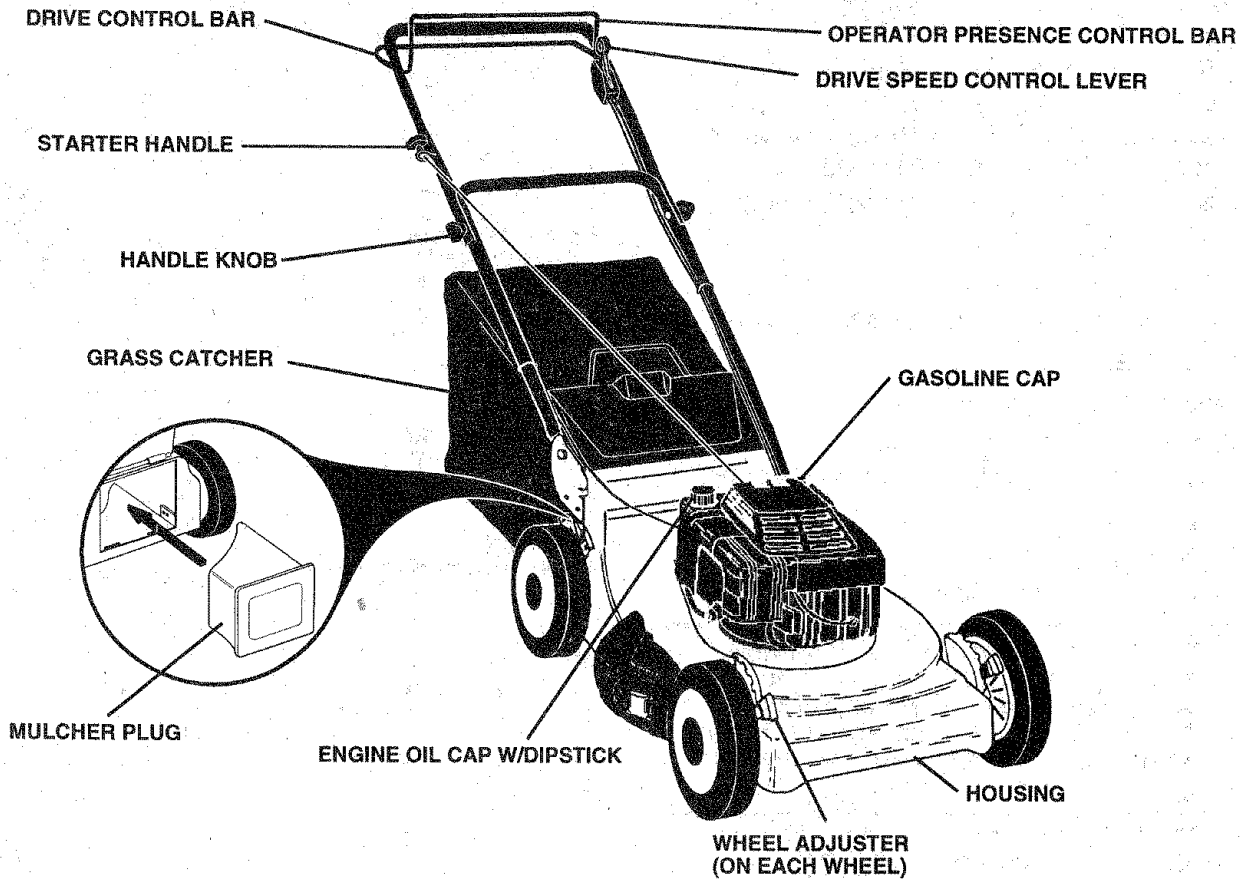
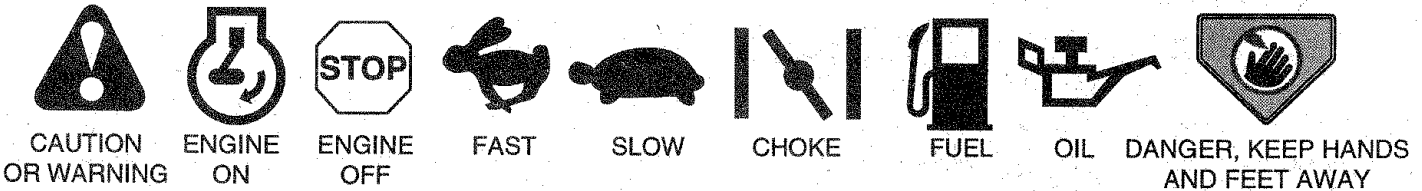

FIG. 6

MEETS CPSC SAFETY REQUIREMENTS

Sears rotary walk-behind power lawn mowers conform to the safety standards of the American National Standards Institute and the U.S. Consumer Product Safety Commission. The blade turns when the engine is running.

OPERATOR PRESENCE CONTROL - must be held down to the handle to start the engine. Release to stop the engine.

DRIVE SPEED CONTROL LEVER - used to select the drive speed of your lawn mower.

STARTER HANDLE - used for starting the engine.

DRIVE CONTROL BAR - used to engage power-propelled forward motion of lawn mower.

MULCHER PLUG - must be removed to convert to bagging or discharging operation.

OPERATION



The operation of any lawn mower can result in foreign objects thrown into the eyes, which can result in severe eye damage. Always wear safety glasses or eye shields while operating your lawn mower or performing any adjustments or repairs. We recommend a wide vision safety mask over the spectacles or standard safety glasses.

HOW TO USE YOUR LAWN MOWER ENGINE SPEED (See Fig. 7)

The engine speed is controlled by a lever located on the side of the engine. High (☛) position is for starting the engine, normal cutting, and better grass bagging. Low (☜) position is for light cutting, trimming and fuel economy.

ENGINE ZONE CONTROL



CAUTION: Federal regulations require an engine control to be installed on this lawn mower in order to minimize the risk of blade contact injury. Do not under any circumstances attempt to defeat the function of the operator control. The blade turns when the engine is running.

- Your lawn mower is equipped with an operator presence control bar which requires the operator to be positioned behind the lawn mower handle to start and operate the lawn mower.

TO CONVERT MOWER

Your lawn mower was shipped ready to be used as a mulcher. To convert to rear bagging or side discharging, see "TO CONVERT MOWER" in Assembly section of this manual.



CAUTION: BEFORE ATTEMPTING TO CONVERT MOWER:

- Release control bar to stop engine.
- Make sure the blade and all moving parts have completely stopped.

TO EMPTY GRASS CATCHER (See Fig. 8)

- Simply lift up rear door and remove the grass catcher by the handle.

NOTE: Do not drag the bag when emptying; it will cause unnecessary wear.

TO ADJUST CUTTING HEIGHT (See Fig. 9)

- Raise wheels for low cut and lower wheels for high cut.
- Adjust cutting height to suit your requirements. Medium position is best for most lawns.
- To change cutting height, squeeze adjuster lever toward wheel. Move wheel up or down to suit your requirements. Be sure all wheels are in the same setting.

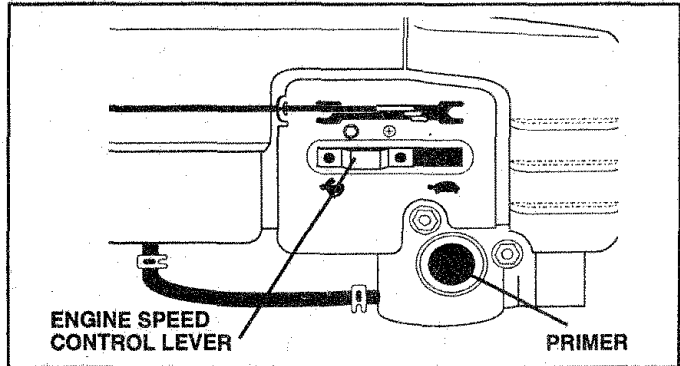

FIG. 7

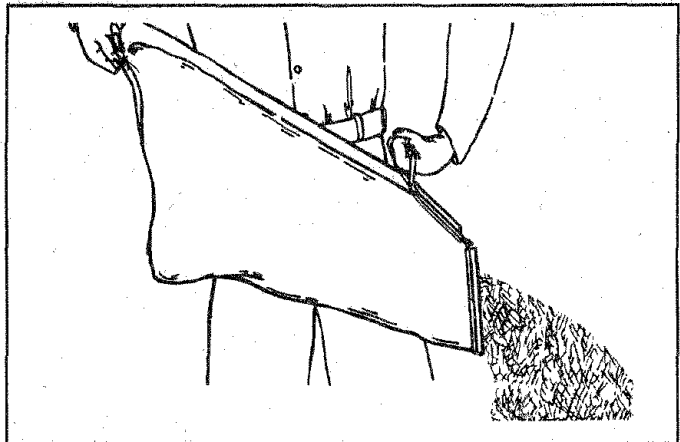

FIG. 8

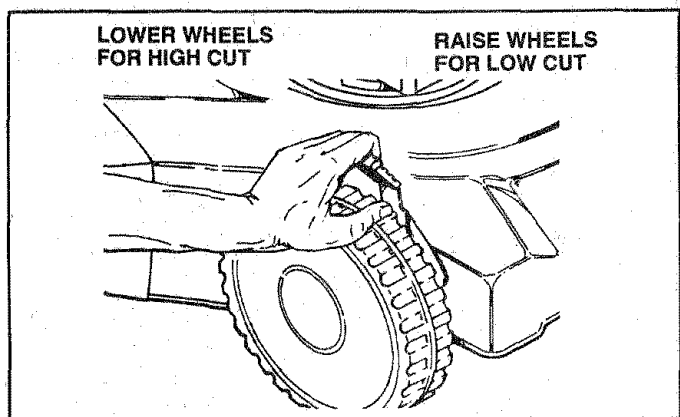

FIG. 9

OPERATION

GROUND DRIVE THREE SPEEDS

(See Fig. 10)

Your lawn mower provides three (3) speeds to let you select the speed that suits you best.

- Speed 1 is for slow, heavy/thick grass cutting or trimming.
- Speed 2 is for normal grass cutting or trimming.
- Speed 3 is for light cutting and for ground transport.

TO OPERATE DRIVE SYSTEM

(See Figs. 10 & 11)

- Select ground speed by moving speed control lever to desired position.
- To start forward motion, lift drive control bar up to handle.
- To stop forward motion, release drive control bar.

IMPORTANT: ALWAYS KEEP DRIVE CONTROL BAR FULLY ENGAGED AGAINST HANDLE WHEN IN USE.

BEFORE STARTING ENGINE

OIL (See Fig. 12)

Your lawn mower is shipped without oil in the engine.

- Be sure mower is level and area around oil fill is clean.
- Remove engine oil cap w/dipstick and fill to the full line on the dipstick.
- Use 27 ozs. of oil. For type and grade of oil to use, see "ENGINE" in Customer Responsibilities section of this manual.
- Pour oil slowly. Do not over fill.
- Check oil level before each use. Add oil if needed. Fill to full line on dipstick.
- To read proper level, tighten engine oil cap each time.
- Reinstall engine oil cap and tighten.
- After the first two (2) hours of mowing, change the oil, and every 25 hours thereafter. You may need to change the oil more often under dusty, dirty conditions.

GAS (See Fig. 12)

- Fill fuel tank. Use fresh, clean, regular unleaded gasoline with a minimum of 87 octane. (Use of leaded gasoline will increase carbon and lead oxide deposits and reduce valve life). Do not mix oil with gasoline. Purchase fuel in quantities that can be used within 30 days to assure fuel freshness.

WARNING: Experience indicates that alcohol blended fuels (called gasohol or using ethanol or methanol) can attract moisture which leads to separation and formation of acids during storage. Acidic gas can damage the fuel system of an engine while in storage. To avoid engine problems, the fuel system should be emptied before storage of 30 days or longer. Drain the fuel tank, start the engine and let it run until fuel lines and carburetor are empty. Use fresh fuel next season. See Storage Instructions for additional information. Never use engine or carburetor cleaner products in fuel tank or permanent damage may occur.

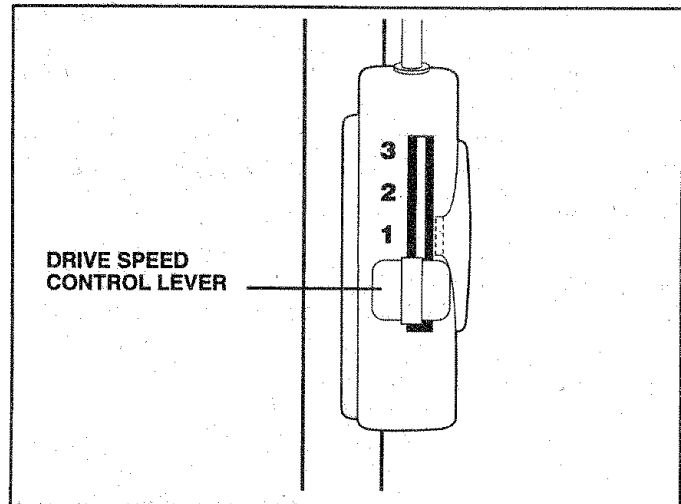

FIG. 10

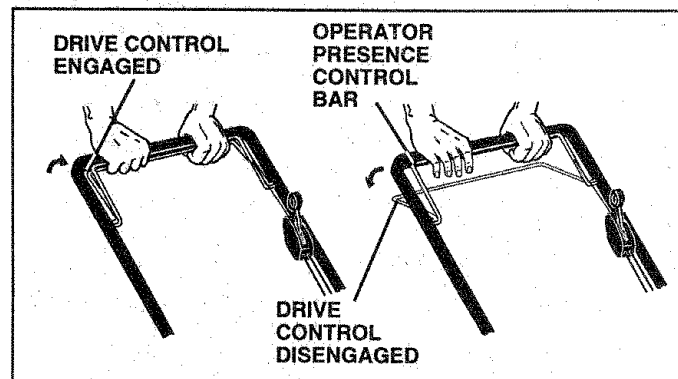

FIG. 11

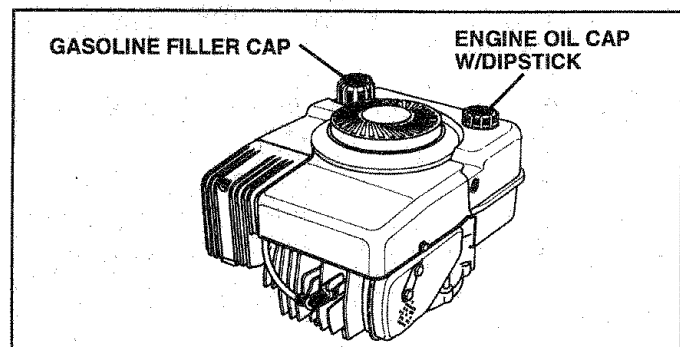

FIG. 12

OPERATION

TO START ENGINE

- To start a cold engine, push primer five (5) times before trying to start. Use a firm push. This step is not usually necessary when starting an engine which has already run for a few minutes.
- Push engine speed control lever to high (⬆) position.
- Hold operator presence control bar down to the handle and pull starter handle quickly. Do not allow starter rope to snap back.
- To stop engine, release operator presence control bar.

NOTE: In cooler weather it may be necessary to repeat priming steps. In warmer weather over priming may cause flooding and engine will not start. If you do flood engine, wait a few minutes before attempting to start and do not repeat priming steps.

MOWING TIPS

- Under certain conditions, such as very tall grass, it may be necessary to raise the height of cut to reduce pushing effort and to keep from overloading the engine and leaving clumps of grass clippings. It may also be necessary to reduce ground speed and/or run the lawn mower over the area a second time.
- For extremely heavy cutting, reduce the width of cut and raise the rear of the lawn mower housing one (1) wheel adjuster setting higher than the front for better discharge of grass.
- For better grass bagging and most cutting conditions, the engine speed should be set in the fast (⬆) position.
- When using a rear discharge lawn mower in moist, heavy grass, clumps of cut grass may not enter the grass catcher. Reduce ground speed (pushing speed) and/or run the lawn mower over the area a second time.
- If a trail of grass clippings is left on the right side of a rear discharge lawn mower, mow in a clockwise direction with a small overlap to collect the clippings on the next pass.
- Keep top of engine around starter clear and clean of grass clippings and chaff. This will help engine air flow and extend engine life.
- Pores in cloth grass catchers can become filled with dirt and dust with use and catchers will collect less grass. To prevent this, regularly hose catchers off with water and let dry before using.

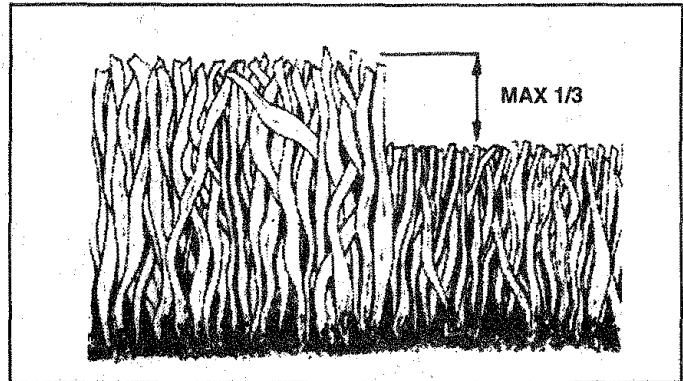

FIG. 13

MULCHING MOWING TIPS

IMPORTANT: FOR BEST PERFORMANCE, KEEP MOWER HOUSING FREE OF BUILT-UP GRASS AND TRASH. SEE "CLEANING" IN CUSTOMER RESPONSIBILITIES SECTION OF THIS MANUAL.

- The special mulching blade will recut the grass clippings many times and reduce them in size so that as they fall onto the lawn they will disperse into the grass and not be noticed. Also, the mulched grass will biodegrade quickly to provide nutrients for the lawn. Always mulch with your highest engine (blade) speed as this will provide the best recutting action of the blades.
- Avoid cutting your lawn when it is wet. Wet grass tends to form clumps and interferes with the mulching action. The best time to mow your lawn is the early afternoon. At this time the grass has dried and the newly cut area will not be exposed to the direct sun.
- For best results, adjust the lawn mower cutting height so that the lawn mower cuts off only the top one-third of the grass blades (See Fig. 13). If the lawn is overgrown it will be necessary to raise the height of cut to reduce pushing effort and to keep from overloading the engine and leaving clumps of mulched grass. For extremely heavy mulching, reduce your width of cut by overlapping previously cut path and mow slowly.
- Certain types of grass and grass conditions may require that an area be mulched a second time to completely hide the clippings. When doing a second cut, mow across or perpendicular to the first cut path.
- Change your cutting pattern from week to week. Mow north to south one week then change to east to west the next week. This will help prevent matting and graining of the lawn.

CUSTOMER RESPONSIBILITIES

MAINTENANCE SCHEDULE		SERVICE DATES						
		BEFORE EACH USE	AFTER EACH USE	FIRST 2 HOURS	EVERY 10 HOURS	EVERY 25 HOURS	EVERY SEASON	BEFORE STORAGE
MOWER	Check for Loose Fasteners	✓						✓
	Clean/Inspect Grass Catcher (If Equipped)	✓	✓					✓
	Clean Lawn Mower		✓					✓
	Clean Under Drive Cover (Self-Propelled Mowers)			✓				
	Check/Sharpen/Replace Blade				✓ ₃			
	Lubrication Chart				✓		✓	
	Clean Battery/Recharge (Electric Start Mowers)				✓		✓ ₄	
ENGINE	Check Engine Oil Level	✓						
	Change Engine Oil		✓		✓ _{1,2}			
	Clean Air Filter				✓ ₂			
	Inspect Muffler				✓			
	Clean or Replace Spark Plug						✓	
	Replace Air Filter Paper Cartridge						✓ ₂	

- 1 - Change more often when operating under a heavy load or in high ambient temperatures.
- 2 - Service more often when operating in dirty or dusty conditions.
- 3 - Replace blades more often when mowing in sandy soil.
- 4 - Charge 48 hours at end of season.

GENERAL RECOMMENDATIONS

The warranty on this lawn mower does not cover items that have been subjected to operator abuse or negligence. To receive full value from the warranty, operator must maintain mower as instructed in this manual.

Some adjustments will need to be made periodically to properly maintain your unit.

All adjustments in the Service and Adjustments section of this manual should be checked at least once each season.

- Once a year, replace the spark plug, replace air filter element and check blade for wear. A new spark plug and clean/new air filter element assures proper air-fuel mixture and helps your engine run better and last longer.
- Follow the maintenance schedule in this manual.

BEFORE EACH USE

- Check engine oil level.
- Check for loose fasteners.

LUBRICATION

Keep unit well lubricated (See "LUBRICATION CHART").

LUBRICATION CHART

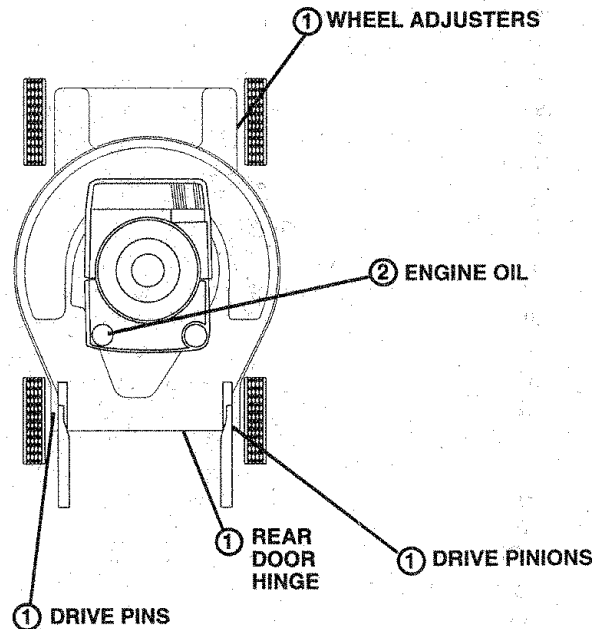

① SPRAY LUBRICANT

② REFER TO CUSTOMER RESPONSIBILITIES "ENGINE" SECTION.

IMPORTANT: DO NOT OIL OR GREASE PLASTIC WHEEL BEARINGS. VISCOUS LUBRICANTS WILL ATTRACT DUST AND DIRT THAT WILL SHORTEN THE LIFE OF THE SELF-LUBRICATING BEARINGS. IF YOU FEEL THEY MUST BE LUBRICATED, USE ONLY A DRY, POWERED GRAPHITE TYPE LUBRICANT SPARINGLY.

CUSTOMER RESPONSIBILITIES

LAWN MOWER

Always observe safety rules when performing any maintenance.

TIRES

- Keep tires free of gasoline, oil, or insect control chemicals which can harm rubber.
- Avoid stumps, stones, deep ruts, sharp objects and other hazards that may cause tire damage.

BLADE CARE

For best results, mower blade must be kept sharp. Replace bent or damaged blades.

TO REMOVE BLADE (See Fig. 14)

- Disconnect spark plug wire from spark plug and place wire where it cannot come in contact with spark plug.
- Turn lawn mower on its side. Make sure air filter and carburetor are up.
- Use a wood block between blade and mower housing to prevent blade from turning when removing blade bolt.
- Protect your hands with gloves and/or wrap blade with heavy cloth.
- Remove blade bolt by turning counter-clockwise.
- Remove blade and attaching hardware (bolt, lock washer and hardened washer).

NOTE: Remove the blade adapter and check the key inside hub of blade adapter. The key must be in good condition to work properly. Replace adapter if damaged.

TO REPLACE BLADE (See Fig. 14)

- Position the blade adapter on the engine crankshaft. Be sure key in adapter and crankshaft keyway are aligned.
- Position blade on the blade adapter aligning the two (2) holes in the blade with the raised lugs on the adapter.
- Be sure the trailing edge of blade (opposite sharp edge) is up toward the engine.
- Install the blade bolt with the lock washer and hardened washer into blade adapter and crankshaft.
- Use block of wood between blade and lawn mower housing and tighten the blade bolt, turning clockwise.
- The recommended tightening torque is 35-40 ft. lbs.

IMPORTANT: BLADE BOLT IS GRADE 8 HEAT TREATED.

NOTE: We do not recommend sharpening blade - but if you do, be sure the blade is balanced.

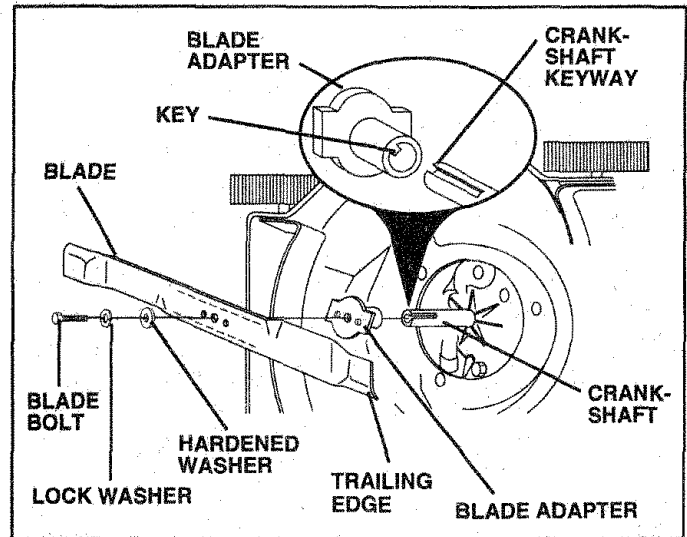

FIG. 14

TO SHARPEN BLADE

Care should be taken to keep the blade balanced. An unbalanced blade will cause eventual damage to lawn mower or engine.

- The blade can be sharpened with a file or on a grinding wheel. Do not attempt to sharpen while on the mower.
- To check blade balance, drive a nail into a beam or wall. Leave about one inch of the straight nail exposed. Place center hole of blade over the head of the nail. If blade is balanced, it should remain in a horizontal position. If either end of the blade moves downward, sharpen the heavy end until the blade is balanced.

GRASS CATCHER

- The grass catcher may be hosed with water, but must be dry when used.
- Check your grass catcher often for damage or deterioration. Through normal use it will wear. If catcher needs replacing, replace only with a manufacturer approved replacement catcher. Give the lawn mower model number when ordering.

CUSTOMER RESPONSIBILITIES

DRIVE WHEELS (See Fig. 15)

Check rear drive wheels each time you mow to be sure they move freely. The wheels not turning freely means trash, grass cuttings, etc., may be inside the drive wheel and dust cover area and must be cleaned out to free drive wheels.

If necessary to clean the drive wheels, check both rear wheels.

- Remove hubcaps and washers.
- Remove wheels from wheel adjuster axles.
- Remove any trash or grass cuttings from inside the dust cover, pinion and/or drive wheel gear teeth.
- If you remove the drive pinions, clean and lubricate with spray lubricant or dry powdered graphite type lubricant before reinstalling.
- The pinion gear must be installed with the left gear on the left side and with the right gear on the right side, from an operator's view.
- The pinion gear is stamped with an "L" (left) or "R" (right) on the inside. If installed incorrectly, the drive system will not work.
- Place wheels back on adjuster axles.
- Replace washers and hubcaps.

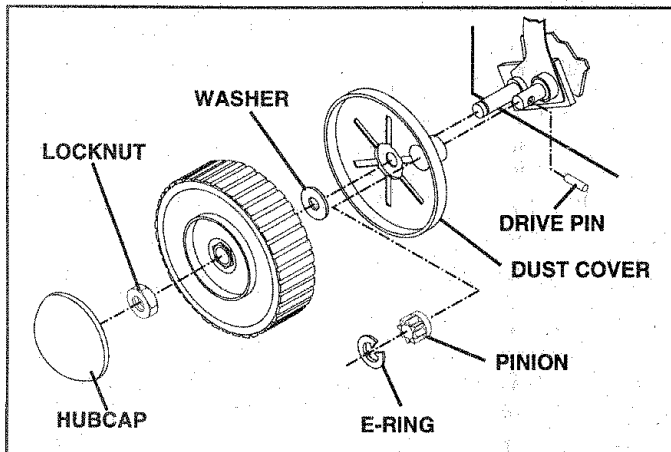
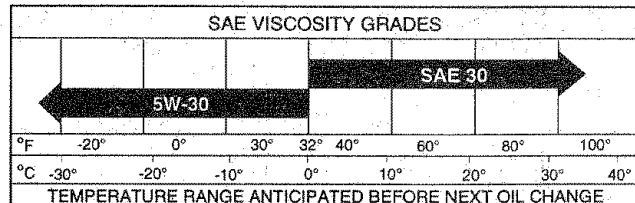

FIG. 15

ENGINE

LUBRICATION

Use only high quality detergent oil rated with API service classification SF or SG. Select the oil's SAE viscosity grade according to your expected operating temperature.



NOTE: Although multi-viscosity oils (5W30, 10W30 etc.) improve starting in cold weather, these multi-viscosity oils will result in increased oil consumption when used above 32°F. Check your engine oil level more frequently to avoid possible engine damage from running low on oil.

Change the oil after the first two hours of operation and every 25 hours thereafter or at least once a year if the lawn mower is not used for 25 hours in one year.

Check the crankcase oil level before starting the engine and after each five (5) hours of continuous use. Tighten oil plug securely each time you check the oil level.

TO CHANGE ENGINE OIL (See Fig. 16)

NOTE: Before tipping lawn mower to drain oil, drain fuel tank by running engine until fuel tank is empty.

- Disconnect spark plug wire from spark plug and place wire where it cannot come in contact with spark plug.
- Remove engine oil cap; lay aside on a clean surface.
- Tip lawn mower on its side and drain oil into a suitable container. Rock lawn mower back and forth to remove any oil trapped inside of engine.
- Wipe off any spilled oil on lawn mower and on side of engine.
- Fill engine with oil. Fill only to the "FULL" line on the dipstick. DO NOT OVER FILL.
- Replace engine oil cap.
- Reconnect spark plug wire to spark plug.

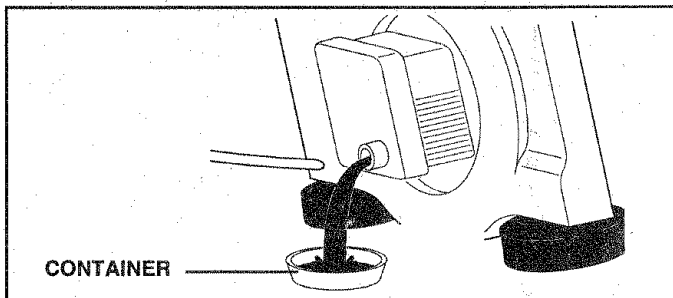

FIG. 16

CUSTOMER RESPONSIBILITIES

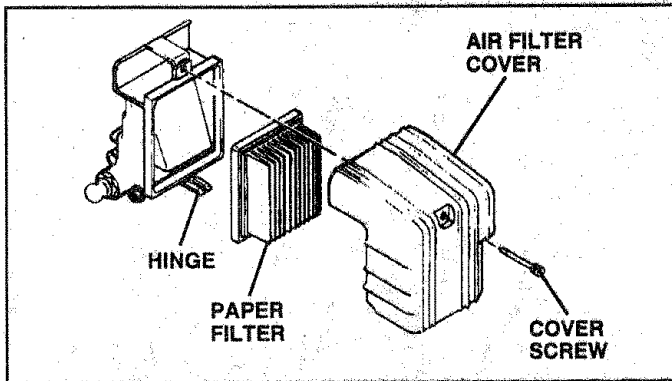

FIG. 17

AIR FILTER

Your engine will not run properly and may be damaged by using a dirty air filter.

Replace the air filter every year, more often if you mow in very dusty, dirty conditions. Do not wash air filter.

TO CHANGE AIR FILTER (See Fig. 17)

- Loosen cover screw.
- Swing cover down and remove from hinge.
- Pull paper filter out of air cleaner body.
- Clean air cleaner cover and body.
- Install a new paper filter.
- Reinstall cover to air cleaner body. Be sure hinge is assembled properly.
- Swing cover up and tighten cover screw. (Do not overtighten).

MUFFLER

Inspect and replace corroded muffler as it could create a fire hazard and/or damage.

SPARK PLUG

Change your spark plug each year to make your engine start easier and run better. Set spark plug gap at .030 inch.

CLEANING

IMPORTANT: FOR BEST PERFORMANCE, KEEP MOWER HOUSING FREE OF BUILT-UP GRASS AND TRASH. CLEAN UNDERSIDE OF MOWER HOUSING AFTER EACH USE.



CAUTION: Disconnect spark plug wire from spark plug and place wire where it cannot come in contact with the spark plug.

- Turn lawn mower on its side. Make sure air filter and carburetor are up. Clean the underside of your lawn mower by scraping to remove build-up of grass and trash.
- Clean engine often to keep trash from accumulating. A clogged engine runs hotter and shortens engine life.
- Keep finished surfaces and wheels free of all gasoline, oil, etc.
- We do not recommend using a garden hose to clean lawn mower unless the electrical system, muffler, air filter and carburetor are covered to keep water out. Water in engine can result in shortened engine life.

CLEAN UNDER DRIVE COVER

Clean under drive cover at least twice a season. Scrape underside of cover with putty knife or similar tool to remove any build-up of trash or grass on underside of drive cover.

SERVICE AND ADJUSTMENTS



CAUTION: BEFORE PERFORMING ANY SERVICE OR ADJUSTMENTS:

- Release control bar and stop engine.
- Make sure the blade and all moving parts have completely stopped.
- Disconnect spark plug wire from spark plug and place where it cannot come in contact with plug.

TO REMOVE/REPLACE DRIVE BELT (See Figs. 18-19)

TO REMOVE BELT:

- Place mower on side with carburetor up.
- Rotate rear wheel to access rear skirt screw.
- Remove rear skirt.
- Use spring puller to remove spring from backplate.
- Use long screwdriver to remove belt from transmission pulley groove.
- Pull belt from engine pulley side and maneuver over blade.

TO INSTALL BELT:

- Maneuver belt around blade onto crankshaft.
- Push belt into plastic baffle and onto engine pulley.
- Use screwdriver to thread belt between cables and transmission.
- Use fingers to push belt into pulley groove.
- Use spring puller to install belt tension spring.
- Install rear skirt.
- Return rear wheel to proper cutting position.

TO ADJUST DRIVE CONTROL (See Fig. 20)

If engagement cable tension needs to be adjusted, proceed as follows:

- Remove control head from upper handle.
- Remove the cable from the control head and reinstall cable positioning block in the next slot down from the bail.
- Reinstall control to upper handle.

TO ADJUST HANDLE (See Fig. 21)

The handle on your lawn mower has three (3) height positions - adjust to height that suits you.

- Squeeze the bottom ends of lower handle towards each other until the pin in handle can be inserted into one of the three height adjustment holes.

REAR DEFLECTOR

The rear deflector, attached between the rear wheels of your lawn mower, is provided to minimize the possibility that objects will be thrown out of the rear of the lawn mower into the operator's mowing position. If the rear deflector becomes damaged, it should be replaced.

ENGINE

ENGINE SPEED

Your engine speed has been factory set. Do not attempt to increase engine speed or it may result in personal injury. If you believe that your engine is running too fast or too slow, take your lawn mower to an authorized service center for repair and/or adjustment.

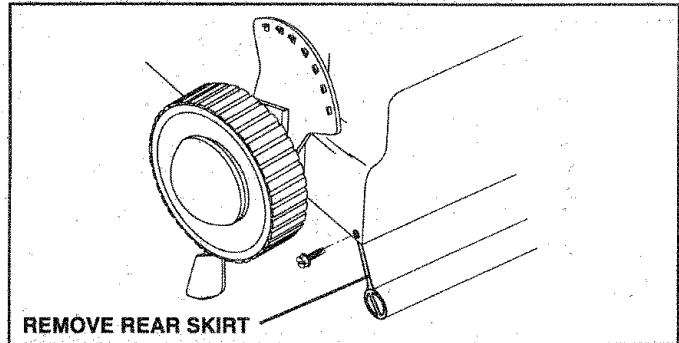

REMOVE REAR SKIRT

FIG. 18

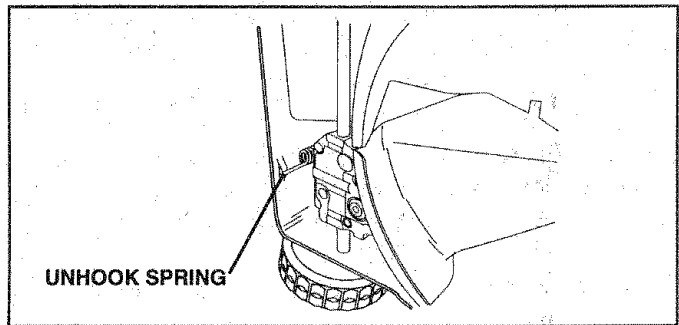

UNHOOK SPRING

FIG. 19

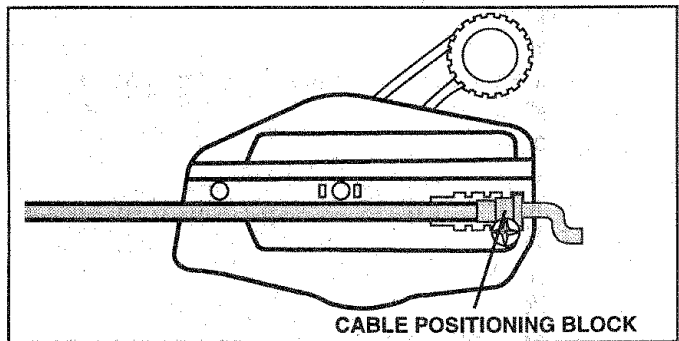

CABLE POSITIONING BLOCK

FIG. 20

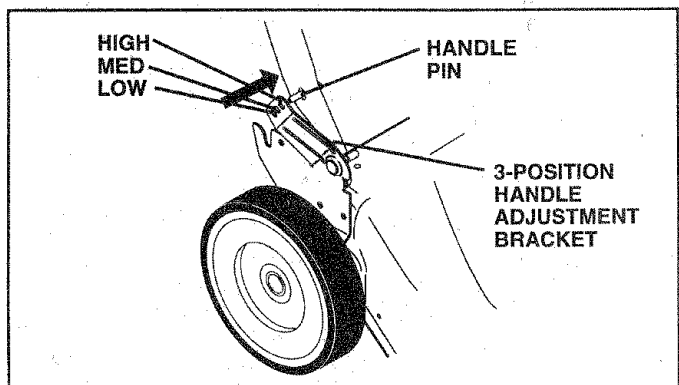

HIGH
MED
LOW

HANDLE
PIN

3-POSITION
HANDLE
ADJUSTMENT
BRACKET

FIG. 21

STORAGE

Immediately prepare your lawn mower for storage at the end of the season or if the unit will not be used for 30 days or more.

LAWN MOWER

When lawn mower is to be stored for a period of time, clean it thoroughly, remove all dirt, grease, leaves, etc. Store in a clean, dry area.

- Clean entire lawn mower (See "CLEANING" in the Customer Responsibilities section of this manual).
- Lubricate as shown in the Customer Responsibilities section of this manual.
- Be sure that all nuts, bolts, screws, and pins are securely fastened. Inspect moving parts for damage, breakage and wear. Replace if necessary.
- Touch up all rusted or chipped paint surfaces; sand lightly before painting.

HANDLE (See Figs. 22 & 23)

- You can fold your lawn mower handle for storage.
- Loosen the two (2) handle knobs on sides of the upper handle and allow handle to fold down to the rear.
- Squeeze the bottom ends of lower handle toward each other until pins in handle clear the brackets and pivot entire handle assembly forward and allow it to rest on mower.
- When setting up your handle from the storage position, the lower handle will require manually locking into the mowing position.

IMPORTANT: WHEN FOLDING THE HANDLE FOR STORAGE OR TRANSPORTATION, BE SURE TO FOLD THE HANDLE AS SHOWN OR YOU MAY DAMAGE THE CONTROL CABLES.

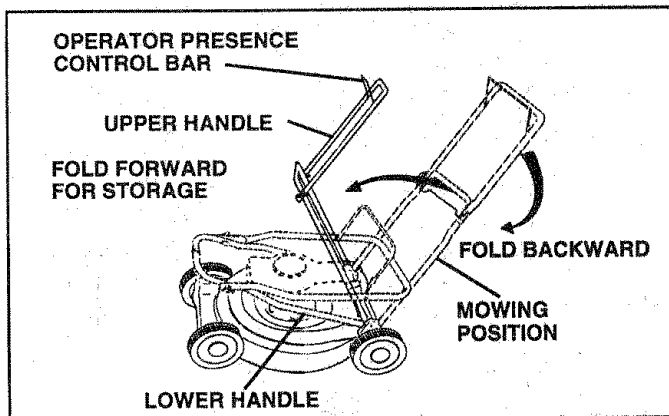

FIG. 22

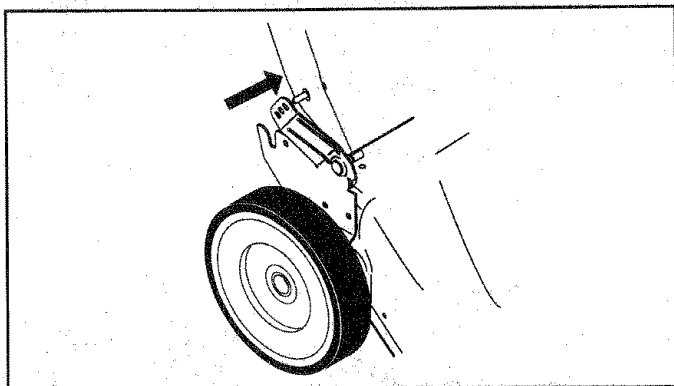

FIG. 23

ENGINE

FUEL SYSTEM

IMPORTANT: IT IS IMPORTANT TO PREVENT GUM DEPOSITS FROM FORMING IN ESSENTIAL FUEL SYSTEM PARTS SUCH AS CARBURETOR, FUEL FILTER, FUEL HOSE, OR TANK DURING STORAGE. ALSO, EXPERIENCE INDICATES THAT ALCOHOL BLENDED FUELS (CALLED GASOHOL OR USING ETHANOL OR METHANOL) CAN ATTRACT MOISTURE WHICH LEADS TO SEPARATION AND FORMATION OF ACIDS DURING STORAGE. ACIDIC GAS CAN DAMAGE THE FUEL SYSTEM OF AN ENGINE WHILE IN STORAGE.

- Drain the fuel tank.
- Start the engine and let it run until the fuel lines and carburetor are empty.
- Never use engine or carburetor cleaner products in the fuel tank or permanent damage may occur.
- Use fresh fuel next season.

NOTE: Fuel stabilizer is an acceptable alternative in minimizing the formation of fuel gum deposits during storage. Add stabilizer to gasoline in fuel tank or storage container. Always follow the mix ratio found on stabilizer container. Run engine at least 10 minutes after adding stabilizer to allow the stabilizer to reach the carburetor. Do not drain the gas tank and carburetor if using fuel stabilizer.

ENGINE OIL

Drain oil (with engine warm) and replace with clean engine oil. (See "ENGINE" in the Customer Responsibilities section of this manual).

CYLINDER

- Remove spark plug.
- Pour one ounce (29 ml) of oil through spark plug hole into cylinder.
- Pull starter handle slowly a few times to distribute oil.
- Replace with new spark plug.

OTHER

- Do not store gasoline from one season to another.
- Replace your gasoline can if your can starts to rust. Rust and/or dirt in your gasoline will cause problems.
- If possible, store your unit indoors and cover it to give protection from dust and dirt.
- Cover your unit with a suitable protective cover that does not retain moisture. Do not use plastic. Plastic cannot breathe which allows condensation to form and will cause your unit to rust.

IMPORTANT: NEVER COVER MOWER WHILE ENGINE AND EXHAUST AREAS ARE STILL WARM.



CAUTION: Never store the lawn mower with gasoline in the tank inside a building where fumes may reach an open flame or spark. Allow the engine to cool before storing in any enclosure.

TROUBLESHOOTING POINTS

PROBLEM	CAUSE	CORRECTION
Does not start	<ol style="list-style-type: none"> 1. Dirty air filter. 2. Out of fuel. 3. Stale fuel. 4. Water in fuel. 5. Spark plug wire is disconnected. 6. Bad spark plug. 7. Loose blade or broken blade adapter. 8. Control bar in released position 9. Control bar defective 	<ol style="list-style-type: none"> 1. Clean/replace air filter. 2. Fill fuel tank. 3. Drain tank and refill with fresh clean fuel. 4. Drain fuel tank and carburetor and refill tank with fresh gasoline. 5. Connect wire to plug. 6. Replace spark plug. 7. Tighten blade bolt or replace blade adapter. 8. Depress control bar to handle. 9. Replace control bar.
Loss of power	<ol style="list-style-type: none"> 1. Rear of lawn mower housing/blade dragging in heavy grass. 2. Cutting too much grass. 3. Dirty air filter. 4. Buildup of grass, leaves and trash under mower. 5. Too much oil in engine. 6. Walking speed too fast. 	<ol style="list-style-type: none"> 1. Set in "Higher Cut" position. 2. Set in "Higher Cut" position. 3. Clean/replace air filter. 4. Clean underside of mower housing. 5. Check oil level. 6. Cut at slower walking speed.
Poor cut - uneven	<ol style="list-style-type: none"> 1. Worn, bent or loose blade. 2. Low engine speed. 3. Buildup of grass, leaves, and trash under mower. 	<ol style="list-style-type: none"> 1. Replace blade. Tighten blade bolt. 2. Set engine speed control in fast position. 3. Clean underside of mower housing.
Excessive vibration	<ol style="list-style-type: none"> 1. Worn, bent or loose blade. 2. Bent engine crankshaft. 	<ol style="list-style-type: none"> 1. Replace blade. Tighten blade bolt. 2. Contact an authorized service center/department.
Starter rope hard to pull	<ol style="list-style-type: none"> 1. Engine flywheel brake is on when control bar is released. 2. Bent engine crankshaft 3. Blade adapter broken. 4. Blade dragging in grass. 	<ol style="list-style-type: none"> 1. Depress control bar to upper handle before pulling starter rope. 2. Contact an authorized service center/department. 3. Replace blade adapter. 4. Move lawn mower to cut grass or to hard surface to start engine.
Grass catcher not filling (if so equipped)	<ol style="list-style-type: none"> 1. Cutting height too low. 2. Lift on blade worn off. 3. Catcher not venting air. 4. Low engine speed. 	<ol style="list-style-type: none"> 1. Raise cutting height. 2. Replace blade. 3. Clean grass catcher. 4. Set engine speed control in fast position.
Hard to push	<ol style="list-style-type: none"> 1. Grass is too high or wheel height is too low. 2. Rear of lawn mower housing/blade dragging in grass. 3. Grass catcher too full. 4. Handle height position not right for you. 	<ol style="list-style-type: none"> 1. Raise cutting height. 2. Raise rear of lawn mower housing one (1) setting higher. 3. Empty grass catcher. 4. Adjust handle height to suit.
Loss of drive	<ol style="list-style-type: none"> 1. Drive not fully engaged. 2. Belt wear. 3. Belt off of pulley. 4. Belt tension spring off. 5. Drive cable worn or broken. 	<ol style="list-style-type: none"> 1. Check and adjust drive control. 2. Check/replace drive belt. 3. Check/reinstall drive belt. 4. Replace belt tension spring. 5. Replace drive cable.

REPAIR PARTS

ROTARY LAWN MOWER MODEL NUMBER 917.376340

GEAR CASE ASSEMBLY 145085

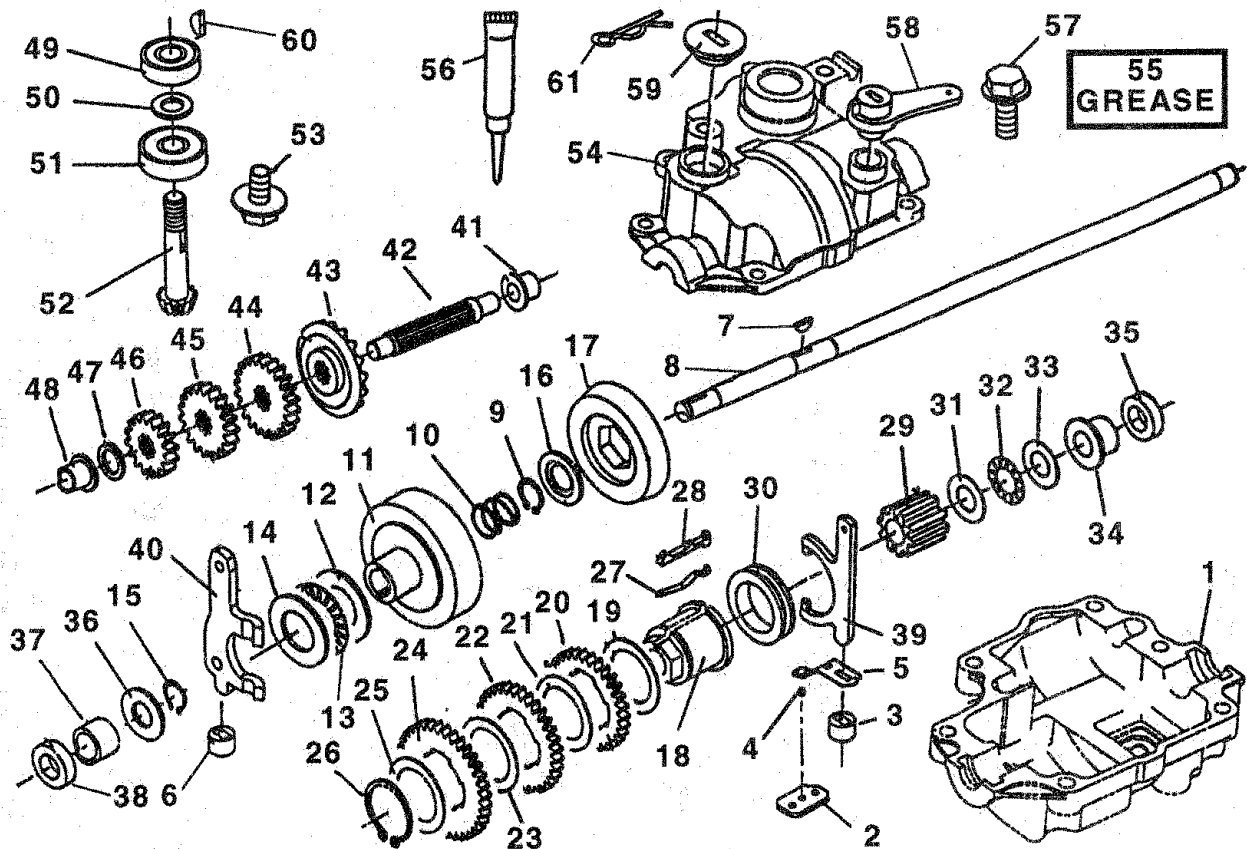

KEY PART NO. NO.

DESCRIPTION

KEY PART NO. NO.

DESCRIPTION

1	148145	Case, Lower
2	148123	Plate, Detent
3	148118	Support, Fork, Shift
4	148135	Ball, Detent
5	148122	Spring, Detent
6	148132	Support, Fork, Clutch
7	148093	Key, Woodruff
8	148114	Axle, Shaft
9	148095	Ring, 12.7
10	148109	Spring, Return
11	148102	Cone, Cave
12	148112	Washer, Thrust
13	148108	Bearing, Thrust, Needle
14	148112	Washer, Thrust
15	148095	Ring, 12.7
16	148096	Washer, Retainer
17	148103	Cone
18	148101	Collar, Shift
19	148097	Washer
20	148090	Gear, 3 Teeth
21	148097	Washer
22	148083	Gear, 3 Teeth
23	148097	Washer
24	148075	Gear, 3 Teeth
25	148097	Washer
26	148113	Ring 28
27	148119	Spring, Shift
28	148121	Key, Shift
29	148098	Support, Key
30	148115	Collar, Shift
31	148111	Washer, Thrust 1/2
32	148110	Bearing, Thrust, Needle

33	148111	Washer, Thrust 1/2
34	148106	Bushing, Transmission 1/2
35	148107	Seal 1/2
36	148096	Washer, Retainer
37	148104	Bushing, Transmission
38	148107	Seal 1/2
39	148116	Fork, Shift
40	148124	Fork, Clutch
41	148069	Bushing
42	148065	Shaft, Reduction
43	148066	Gear, Bevel 3 Teeth
44	148089	Gear, Spur 2 Teeth
45	148080	Gear, Spur 1 Tooth
46	148072	Gear, Spur 1 Tooth
47	148067	Washer
48	148069	Bushing
49	148141	Bearing, Ball 6000U
50	148139	Washer, 10
51	148140	Bearing, Ball 6200
52	148137	Shaft, Input
53	148146	Screw, Self-Tapping
54	148144	Case, Upper
55	---	Grease
56	148142	Sealant
57	148147	Screw, Self-Tapping, Case
58	148117	Arm, Shift
59	148127	Support, Upper, Clutch
60	148138	Key, Woodruff
61	148133	Pin, Snap 14

NOTE: All component dimensions given in U.S. inches
1 inch = 25.4 mm

REPAIR PARTS

ROTARY LAWN MOWER MODEL NUMBER 917.376340

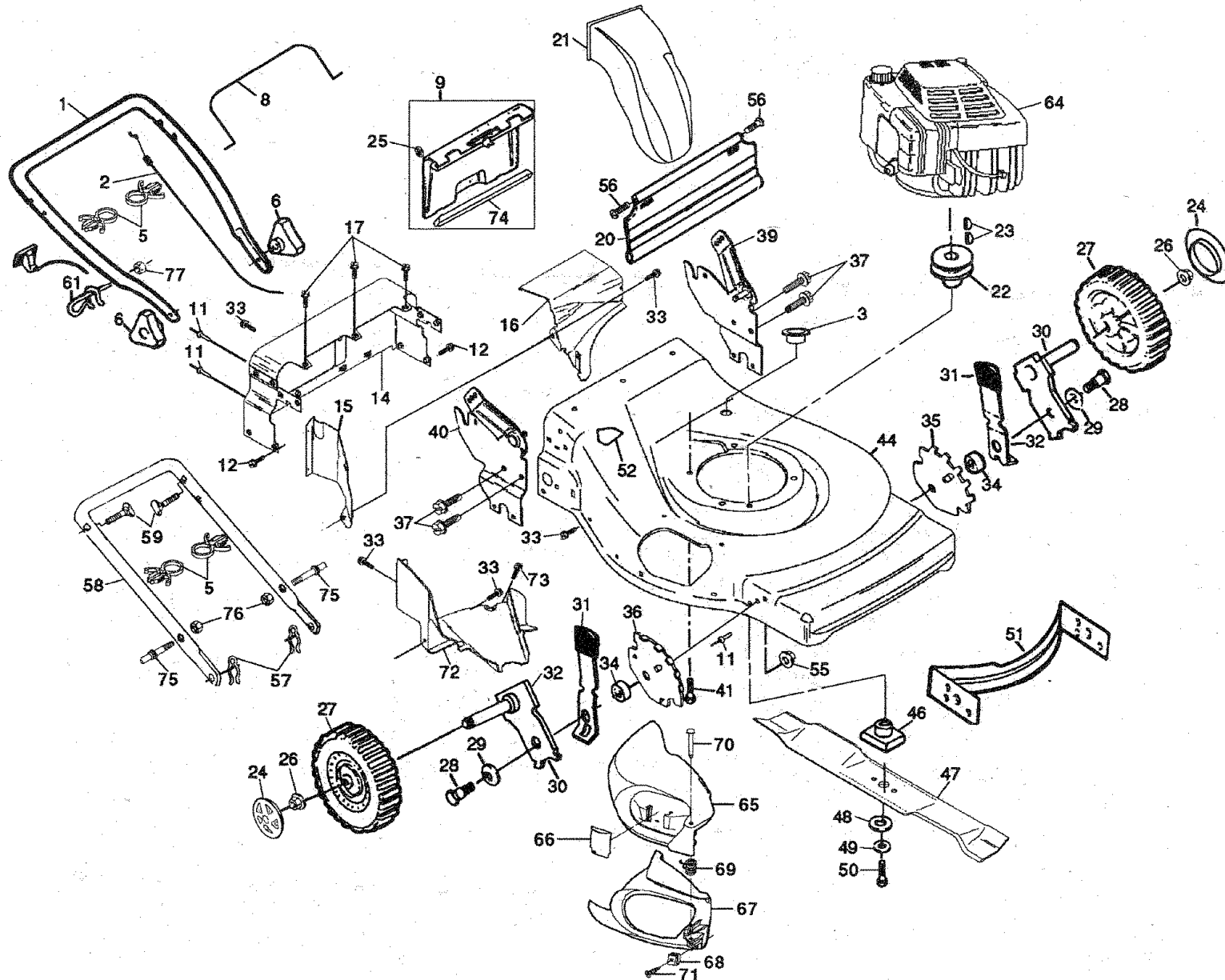

REPAIR PARTS

ROTARY LAWN MOWER MODEL NUMBER 917.376340

KEY NO.	PART NO	DESCRIPTION	KEY NO.	PART NO	DESCRIPTION
1	153346X479	Upper Handle	44	48391	Lawn Mower Housing (Incl. Key #14, 15, 51 & 52)
2	145067	Engine Zone Control Cable	46	851514	Blade Adapter
3	145073	Grommet, Cable	47	141443	Blade 22"
5	151517	Cable Clip	48	851074	Hardened Washer
6	87692	Handle Knob	49	850263	Helical Washer 3/8-24 x 1-3/8 Grd. 8
7	STD541425	Locknut 1/4-20	50	851084	Hex Head Machine Screw 3/8-24 x 1-3/8 Grd. 8
8	145641	Control Bar, Engine	51	700869X479	Front Baffle
9	147690	Rear Door Kit	52	85463	Danger Decal
10	147551	Throttle Control	55	751592	Locknut 3/8-16
11	128415	Pop Rivets	56	88652	Hinge Screw
12	STD512505	Hex Tapping Screw 1/4-20 x 1/2	57	51793	Hairpin Cotter
13	59935	Screw	58	151723X479	Lower Handle
14	144991X479	Back Plate	59	131959	Handle Bolt
15	145594X479	Side Baffle	61	132001	Rope Guide
16	145066X479	Discharge Baffle	64	152258	Engine - Craftsman - Model No. 143.966500
17	149027	Truss Head Tapping Screw 1/4-20 x 1/2	65	701458	Door
20	140540	Rear Skirt	66	143984X479	Door Latch
21	150099	Mulcher Plug	67	702807	Side Discharge Guard
22	85543	Engine Pulley	68	141839	Speed Nut
23	87677	Hi-Pro Key #505	69	702808	Hinge Spring
24	150182	Hubcap	70	702809	Hinge Rod
25	12000014	E-Ring	71	141841	Screw
26	83923	Nut, Hex Flange	72	145062	Baffle/Belt Cover
27	150339	Wheel & Tire Assembly	73	17411312	Screw
28	142748	Shoulder Bolt 3/8-16	74	146337	Door Seal
29	62335	Belleville Washer	75	150502	Quick Adjust Handle Bolt
30	145937X004	Axle Arm Assembly	76	73990500	Locknut
31	701037	Selector Knob	77	73510400	Keps Nut
32	850862X004	Selector Spring	--	153367	Owner's Manual (English/Spanish)
33	150050	Screw, Hex Tapping #10-16 x 1/2			
34	146630	Spacer			
35	146234	Wheel Adjusting Bracket (Left)	71	33623	Gas Can (2.5 gal.)
36	146233	Wheel Adjusting Bracket (Right)	71	33500	Fuel Stabilizer
37	55187	Thread Cutting Screw 5/16-18 x 3/4	71	33027	SAE 30W Oil (27 oz.)
39	153304X479	Handle Bracket Assembly (Left)	71	33417	Dust Shield
40	153305X479	Handle Bracket Assembly (Right)	71	33316	Mower Cover
41	150406	Hex Head Thread Rolling Screw 3/8-16 x 1-1/8			

Available accessories not included with lawn mower:

- 71 33623 Gas Can (2.5 gal.)
- 71 33500 Fuel Stabilizer
- 71 33027 SAE 30W Oil (27 oz.)
- 71 33417 Dust Shield
- 71 33316 Mower Cover

REPAIR PARTS

ROTARY LAWN MOWER MODEL NUMBER 917.376340

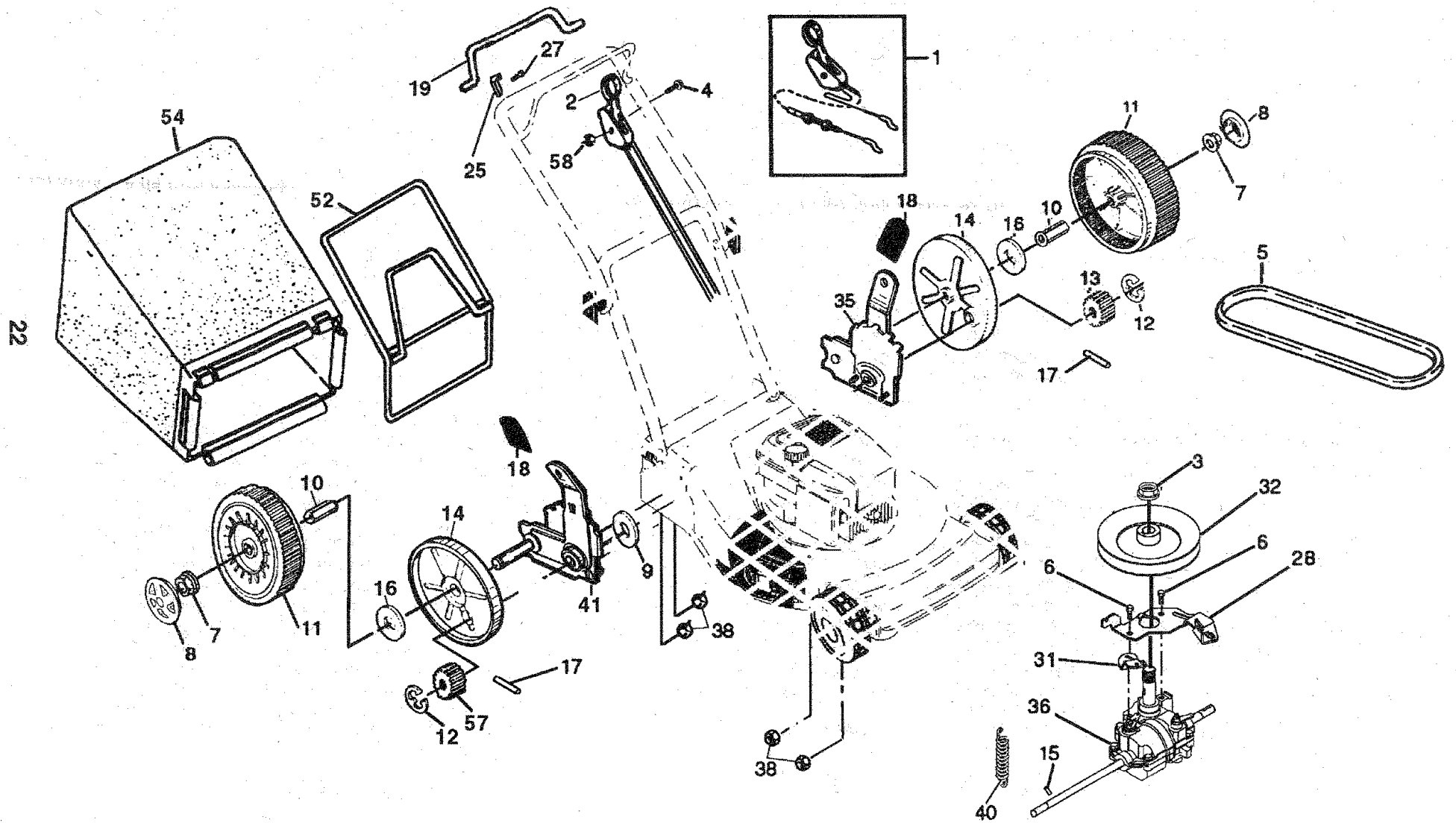

REPAIR PARTS

ROTARY LAWN MOWER MODEL NUMBER 917.376340

KEY NO.	PART NO.	DESCRIPTION
1	147715	Drive Head Kit
2	145088	Drive Control
3	M73031000	Nut, Metric
4	144929	Screw 1/4-20
5	145084	V-Belt
6	146315	Screw
7	145212	Nut, Hex Flange
8	150182	Hubcap
9	57079	Washer
10	88446	Nylon Bushing
11	150340	Wheel & Tire Assembly
12	12000058	E-Ring
13	850017	Pinion, L.H.
14	88080	Dust Cover
15	145354	Pin, Spring Thrust

KEY NO.	PART NO.	DESCRIPTION
16	67725	Washer 1/2 x 1-1/2 x .134
17	851980	Drive Pin
18	701037	Selector Knob
19	145071	Control Bar, Drive
25	850733X004	Upstop Bracket
27	750097	Screw #10-24 x 1/2
28	145096X004	Bracket, Gearcase
31	145842X004	Lever, Clutch
32	145093	Drive Pulley
35	48393	Wheel Adjuster Assembly (Left)
36	145085	Gear Case Assembly
38	STD541425	Hex Locknut 1/4-20
40	144902	Spring, Belt Tension
41	48392	Wheel Adjuster Assembly (Right)
52	150224	Catcher Frame
54	150257	Grassbag Assembly
57	850016	Pinion, R.H.
58	751152	Nut

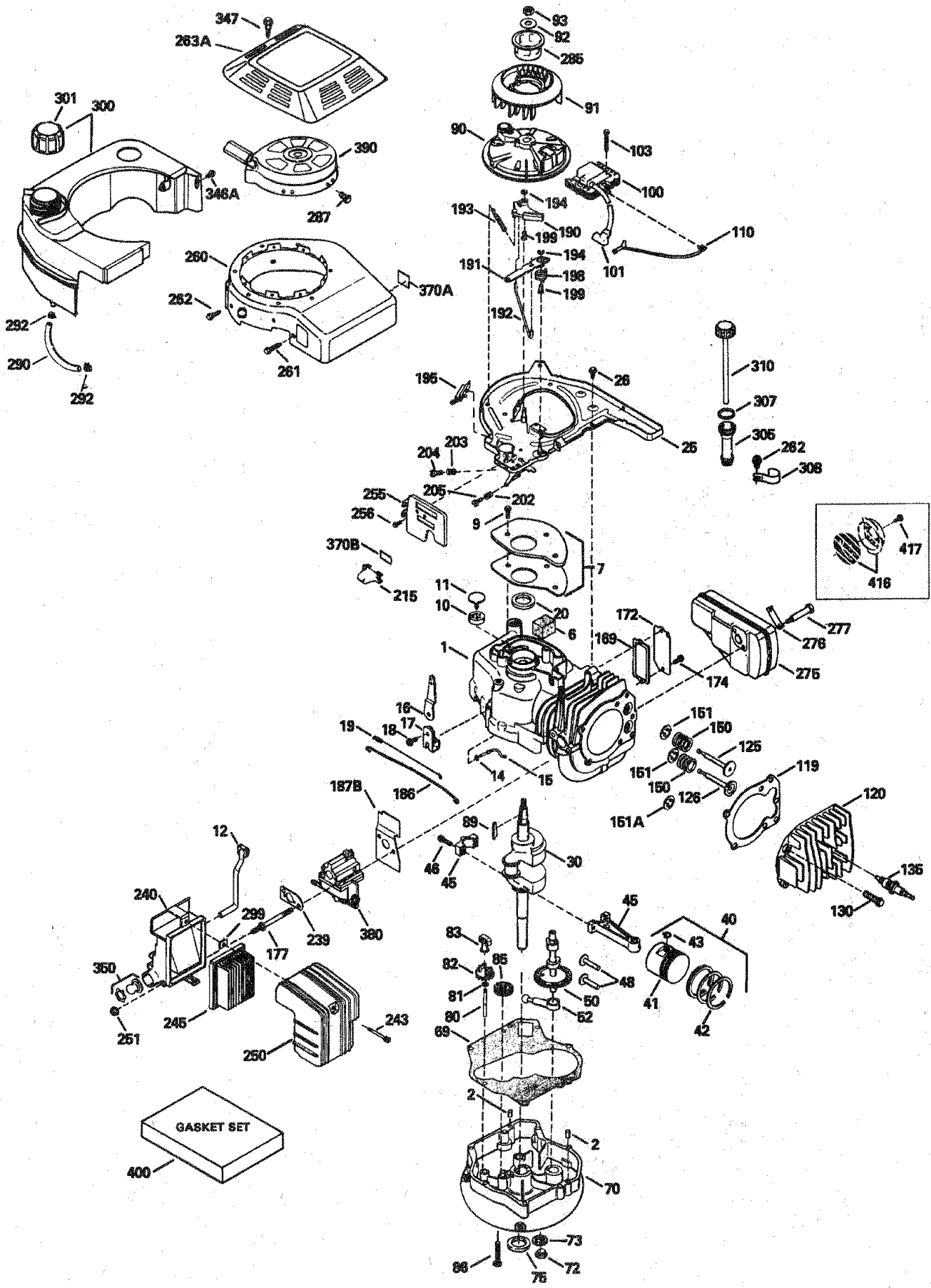

4-CYCLE ENGINE

MODEL NUMBER 143.966500

REF NO.	PART NO.	DESCRIPTION	REF NO.	PART NO.	DESCRIPTION
1	36146	Cylinder (Incl. 2,10,20 & 125)	169	27234A	* Valve Spring Box Gasket
2	27652	Dowel Pin	172	32755	Valve Spring Box Cover
6	36059	Breather Element	174	30200	Screw, 10-24 x 9/16"
7	36005A	Breather Cover & Gasket	177	650925	Carburetor Mounting Stud
9	590568	Screw, 10-24 x 3/4"	186	36009	Governor Link
10	36002	Breather Valve Body	187B	36035	* Carburetor Gasket/Air Baffle
11	36003	Check Valve	190	36013	Brake Lever Ass'y.
12	36001	Breather Tube	191	36012	Brake Control Lever
14	28277	Flat Washer	192	36016	Brake Control Lever Link
15	36006	Governor Rod (Machined)	193	36015	Brake Spring
16	36008	Governor Lever	194	36014	Retaining Ring
17	31335	Governor Lever Clamp	195	610973	Terminal Ass'y.
18	650548	Screw, 8-32 x 5/16"	198	36017	Brake Control Lever Spring
19	36103	Governor Spring	199	36018	Brake Lever Bushing
20	36010	Oil Seal	202	36482	Compression Spring
25	36011	Blower Housing Baffle Ass'y.(Incl.195)	203	36482	Compression Spring
26	650802	Screw, 1/4-20 x 5/8"	204	650549	Screw, 5-40 x 7/16"
30	36111	Crankshaft	205	650777	Screw, 6-32 x 21/32"
40	36073	Piston,Pin, Ring Set (Std.)	215	36051	Control Knob
40	36074	Piston,Pin, Ring Set (.010 OS)	239	36048	* Carburetor to Air Cleaner Gasket
40	36075	Piston,Pin, Ring Set (.020 OS)	240	36044A	Air Cleaner Body (Incl.239,299 & 350)
41	36070	Piston & Pin Ass'y.(Std.) (Incl. 43)	243	650899	Screw, 10-32 x 2-3/32"
41	36071	Piston & Pin Ass'y.(.010 OS)(Incl.43)	245	36046	Air Cleaner Filter
41	36072	Piston & Pin Ass'y.(.020 OS)(Incl.43)	250	36154	Air Cleaner Cover
42	36076	Ring Set (Std.)	251	650928	Lock Nut 1/4-20
42	36077	Ring Set (.010 OS)	255	36110	Control Plate
42	36078	Ring Set (.020 OS)	256	650983	Screw, 8-32 x 21/64"
43	20381	Piston Pin Retaining Ring	260	36153	Blower Housing
45	36023A	Connecting Rod Ass'y. (Incl. 46)	261	650737	Screw, 1/4-20 x 1/2"
46	32610A	Connecting Rod Bolt	262	650929	Screw, 1/4-20 x 11/16"
48	36030	Valve Lifter	263A	36156	Starter Grill
50	36031	Camshaft (MCR)	275	36107	Muffler
52	29914	Oil Pump Ass'y.	276	36043	Locking Plate
69	36032A	Mounting Flange Gasket	277	650927	Screw, 5/6-18 x 2-11/32"
70	36151	Mounting Flange (Incl. 72 thru 85)	285	34449A	Starter Cup
72	30572	Oil Drain Plug (Incl. 73)	287	650926	Screw, 8-32 x 21/64"
73	28833	Drain Plug Gasket	290	34357	Fuel Line
75	36010	Oil Seal	292	26460	Fuel Line Clamp
80	30574A	Governor Shaft	299	650900	"U" Type Nut Clip
81	30590A	Washer	300	36066	Fuel Tank (Incl. 301)
82	30591	Governor Gear Ass'y. (Include.81)	301	36246	Fuel Cap
83	36057	Governor Spool	305	36063	Oil Fill Tube
85	36034	Idler Gear	307	35499	"O" Ring
86	650924	Screw, 1/4-20 x 1-9/16"	308	36040	Fill Tube Clip
89	611154	Flywheel Key	310	36064	Dipstick
90	611155	Flywheel	346A	28763	Screw, 10-32 x 35/64"
91	611156	Flywheel Fan	347	650898	Screw, 10-32 x 27/32"
92	650815	Belleville Washer	350	36045	Primer
93	650816	Flywheel Nut	370A	36261	Lubrication Decal
100	34443A	Solid State Ignition	370B	36155	Control Decal
101	610118	Spark Plug Cover	380	632671	Carburetor (Incl. 187B & 239)
103	651007	Screw, Torx T-15, 10-24 x 15/16"	390	590702	Rewind Starter
110	36054	Ground Wire	400	36121A	Gasket Set
119	36119	Cylinder Head Gasket	416	36085	Spark Arrestor Kit (Incl. 417)(Optional)
120	36120	Cylinder Head	417	650760	Screw, 8-32 x 3/8" (Optional)
125	36471	Exhaust Valve (Std.) (Incl. 151)			RPM High 2900 to 3200
125	36472	Exhaust Valve (1/32" OS)			RPM Low 2450 to 2750
126	29314B	Intake Valve (Std.) (Incl. 151)			
126	29315C	Intake Valve (1/32" OS)			
130	6021A	Screw, 5/16-18 x 1-1/2"			
135	35395	Resistor Spark Plug (RJ19LM)			
150	31672	Valve Spring			
151	31673	Lower Valve Spring Cap			
151A	40008	Intake Valve Seal			

(NOTE: This engine could have been built with 590739 starter. Refer to the design of the rope pulley strength ribs for part identification. Individual starter parts do not interchange.) (Gasket Set Incl. Items Marked *)

25 NOTE: All component dimensions given in U.S. inches
1 inch = 25.4 mm

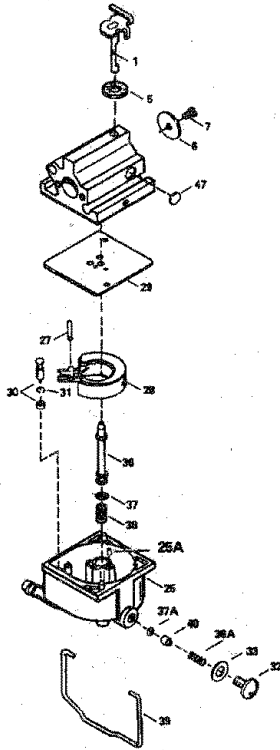

REF NO.	PART NO.	DESCRIPTION
--	632671	Carburetor (Incl. 187B & 239 of Engine Parts List)
1	632539	Throttle Shaft & Lever Assembly
5	632593	Dust Seal
6	632541	Throttle Shutter
7	650506	Throttle Shutter Screw
25	632675	Float Bowl
25	A632701	Idle Restrictor
27	632544	Float Shaft
28	632543	Float
29	632548	Float Bowl to Body Gasket
30	632551	Inlet Needle, Seat & Seat Retainer (Incl. 31)
31	632637	Seat Retainer
32	632672	Bowl Drain Screw
33	632673	Bowl Drain Washer
36	632674	Main Nozzle Tube
37	632547	"O" Ring, Main Nozzle Tube
37A	632547	"O" Ring
38	632545	Spring, Main Nozzle Tube
38A	632545	Spring
39	632549	Float Bowl Retainer
40	632676	Main Fuel Jet
47	632554	Welch Plug, Idle Mixing Well

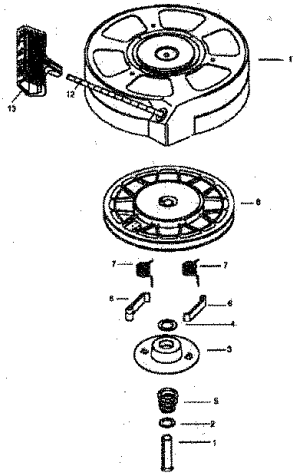

REF NO.	PART NO.	DESCRIPTION
--	590702	Recoil Starter
1	590599A	Spring Pin (Incl. 4)
2	590600	Washer
3	590696	Retainer
4	590601	Washer
5	590697	Brake Spring
6	590698	Starter Dog
7	590699	Dog Spring
8	590700	Pulley & Rewind Spring Ass'y.
11	590703	Starter Housing Ass'y. (40 degree grommet)
12	590535	Starter Rope (98" X 9/64" dia.)
13	590701	Starter Handle

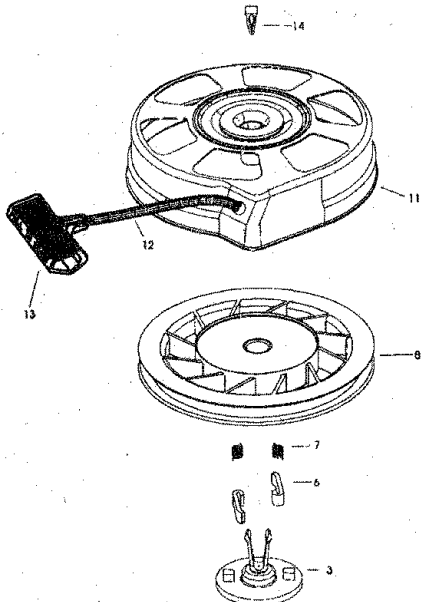

REF NO.	PART NO.	DESCRIPTION
--	590739	Rewind Starter
3	590740	Retainer
6	590616	Starter Dog
7	590617	Dog Spring
8	590618A	Pulley & Rewind Spring Ass'y
11	590638	Starter Housing Ass'y (40 degree grommet)
12	590535	Starter Rope (Length 98" x 9/64" dia.)
13	590701	Starter Handle
14	590741	Locking Tab

NOTE: All component dimensions given in U.S. inches
1 inch = 25.4 mm

SERVICE NOTES

SEARS

OWNER'S MANUAL

**MODEL NO.
917.376340**

IF YOU NEED REPAIR SERVICE OR PARTS:

FOR REPAIR SERVICE, CALL
THIS TOLL FREE NUMBER:

1-800-4-REPAIR
(1-800-473-7247)

FOR REPLACEMENT PARTS
INFORMATION AND
ORDERING, CALL THIS
TOLL FREE NUMBER:

1-800-FON-PART
(1-800-366-7278)

CRAFTSMAN®

6.5 HORSEPOWER 22" POWER PROPELLED ROTARY LAWN MOWER

Each lawn mower has its own model number. Each engine has its own model number.

The model number for your lawn mower will be found on a decal attached to the rear of the lawn mower housing.

The model number for your engine will be found on the blower housing of the engine.

All parts listed herein may be ordered from any Sears, Roebuck and Co. Service Center/Department and most Retail Stores.

WHEN ORDERING REPAIR PARTS, ALWAYS GIVE THE FOLLOWING INFORMATION:

- **PRODUCT - LAWN MOWER**
- **MODEL NUMBER - 917.376340**
- **ENGINE - MODEL NO. - 143.966500**
- **PART NUMBER**
- **PART DESCRIPTION**

Your Sears merchandise has added value when you consider Sears has service units nationwide staffed with Sears trained technicians... professional technicians specifically trained to insure that we meet our pledge to you, we service what we sell.