

3820/3810

SINGER®

Instruction Manual

IMPORTANT SAFETY INSTRUCTIONS

When using an electrical appliance, basic safety precautions should always be followed, including the following:

Read all instructions before using this sewing machine.

DANGER — To reduce the risk of electric shock:

1. An appliance should never be left unattended when plugged in.
2. Always unplug this appliance from the electric outlet immediately after using and before cleaning.
3. Always unplug before relamping. Replace bulb with same type rated 10 watts.

WARNING — To reduce the risk of burns, fire, electric shock, or injury to persons:

1. Do not allow to be used as a toy. Close attention is necessary when this appliance is used by or near children.
2. Use this appliance only for its intended use as described in this manual. Use only attachments recommended by the manufacturer as contained in this manual.
3. Never operate this appliance if it has a damaged cord or plug, if it is not working properly, if it has been dropped or damaged, or dropped into water. Return the appliance to the nearest authorized dealer or service center for examination, repair, electrical or mechanical adjustment.
4. Never operate the appliance with any air openings blocked. Keep ventilation openings of the sewing machine and foot controller free from accumulation of lint, dust, and loose cloth.

5. Keep fingers away from all moving parts. Special care is required around the sewing machine needle.
6. Always use the proper needle plate. The wrong plate can cause the needle to break.
7. Do not use bent needles.
8. Do not pull or push fabric while stitching. It may deflect the needle causing it to break.
9. Switch the sewing machine off (“0”) when making any adjustments in the needle area, such as threading needle, changing needle, threading bobbin, or changing presser foot, and the like.
10. Always unplug sewing machine from the electrical outlet when removing covers, lubricating, or when making any other user servicing adjustments mentioned in the instruction manual.
11. Never drop or insert any object into any opening.
12. Do not use outdoors.
13. Do not operate where aerosol (spray products) are being used or where oxygen is being administered.
14. To disconnect, turn all controls to the off (“0”) position, then remove plug from outlet.
15. Do not unplug by pulling on cord. To unplug, grasp the plug, not the cord.

SAVE THESE INSTRUCTIONS

This sewing machine is intended for household use only.

Congratulations

As the owner of a new Singer sewing machine, you are about to begin an exciting adventure in creativity. From the moment you first use your machine, you will know you are sewing on one of the easiest to use sewing machines ever made.

May we recommend that, before you start to use your sewing machine, you discover the many advantages and the ease of operation by going through this instruction book, step by step, seated at your machine.

To ensure that you are always provided with the most modern sewing capabilities, the manufacturer reserves the right to change the appearance, design or accessories of this sewing machine when considered necessary.

SINGER IS A REGISTERED TRADEMARK OF THE SINGER COMPANY LIMITED

Copyright © 2000

All rights reserved throughout the world.

Please note: This Instruction Book covers the operation of multiple models of sewing machines and the use of optional accessories. The manufacturer has made every effort to clearly define the differences between the different models and to define when an accessory is an optional extra. Please read carefully to determine which instructions apply to your particular model machine. For a clear definition of your sewing machine please see pages 19, 20 and 21.

List of contents

Principal parts of the machine.....	2.3	Sewing on buttons (For 3 dial models)	31
Accessories	4	How to sew buttonholes (one-step buttonholes).....	32
Installing the snap-in sewing table	5	Left and right side balance for buttonhole.....	33
Connecting machine to power source.....	6	Zippers and piping (For 2 dial model)	34
Changing the bulb.....	7	Zippers and piping (For 3 dial models)	35
Two-step presser foot lifter	8	Sewing with the optional hemmer foot (For 2 dial model).....	36
Attaching the presser foot holder	9	Sewing with the optional hemmer foot (For 3 dial models)	37
Winding the bobbin	10	Multi-stitch zig-zag (For 2 dial model).....	38
Inserting the bobbin	11	Multi-stitch zig-zag (For 3 dial models)	39
Inserting and changing needles	12	Straight stretch stitch (For 2 dial model)	40
Threading the upper thread	13	Straight stretch stitch and Ric Rac stitch (For 3 dial models) ..	41
Optional automatic needle threader.....	14	Honeycomb stitch (For 3 dial models)	42
Thread tension.....	15	Sewing with the optional cording foot (For 2 dial model)	43
Raising the bobbin thread.....	16	Sewing with the optional cording foot (For 3 dial models)	44
Reverse sewing/Removing the work/cutting the thread	17	Free motion darning (For 2 dial model)	45
Matching Needle/fabric/thread	18	Free motion darning (For 3 dial models).....	46
How to choose your pattern (For 2 dial model)	19	Practical stitches (For 2 dial model).....	47
How to choose your pattern (For 3 dial 20 stitch model).....	20	Practical stitches (For 3 dial models).....	48
How to choose your pattern (For 3 dial 25 stitch model).....	21	Darning.....	49
Straight stitching and needle position (For 2 dial model)	22	Attaching lace.....	50
Straight stitching and needle position (For 3 dial models).....	23	Applique	51
Zigzag stitching (For 2 dial model).....	24	Monogramming and embroidering with embroidery hoop.....	52
Zigzag stitching (For 3 dial models)	25	Quilting	53
Blind hem/lingerie stitch (For 3 dial models)	26	Gathering.....	54
Overlock stitches (For 2 dial model).....	27	The evenfeed foot optional accessory	55
Overlock stitches (For 3 dial 20 stitch model)	28	Maintenance.....	56
Overlock stitches (For 3 dial 25 stitch model)	29	Trouble shooting guide	57
Sewing on buttons (For 2 dial model)	30		

□ Principal parts of the machine

1. Handle
2. Horizontal spool pin and spool holder
3. Tension dial
4. Presser foot pressure adjustment
5. Thread take up lever
6. Face plate
7. Reverse lever
8. Thread cutter
9. One step buttonhole lever (optional on some models)
10. Automatic threader (option on some models)
11. Presser foot
12. Removable sewing table/accessory storage
13. Hole for second spool pin
14. Bobbin winder
15. Stitch length dial
16. Stitch width dial (for 3 dial models)*
17. Pattern indicator window

* Note: If your machine does not have a stitch width dial, it will be referred to as a "2 dial model" throughout this instruction book.

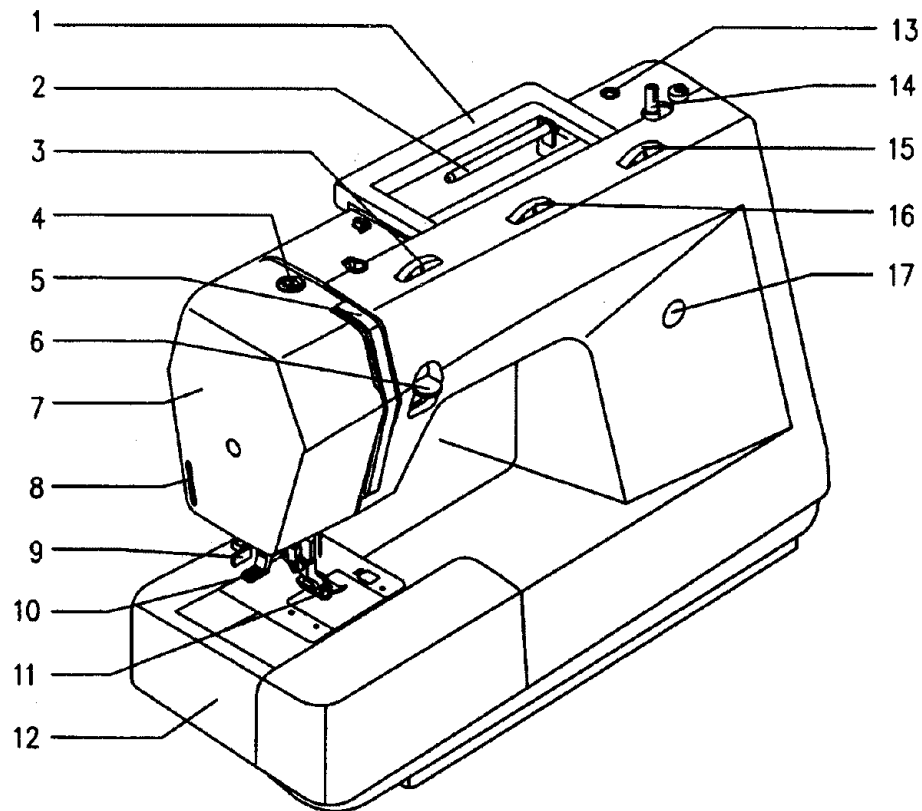

□ Principal parts of the machine

- 18. Handwheel
- 19. Pattern selector dial
- 20. Buttonhole stitch balance adjustment slot
- 21. Power and light switch
- 22. Main plug socket
- 23. Upper thread guide
- 24. Drop feed control
- 25. Presser foot lifter
- 26. Foot Speed Control
- 27. Power cord
- 28. Needle Plate
- 29. One-way needle clamp
- 30. Bobbin cover plate
- 31. Feed System (feed dog)

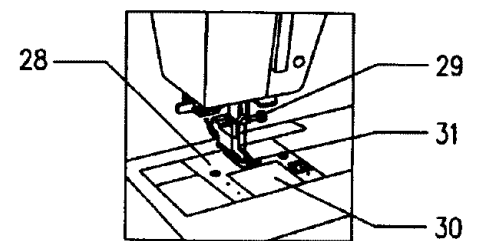
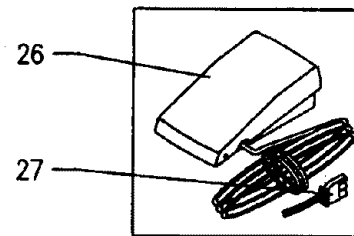
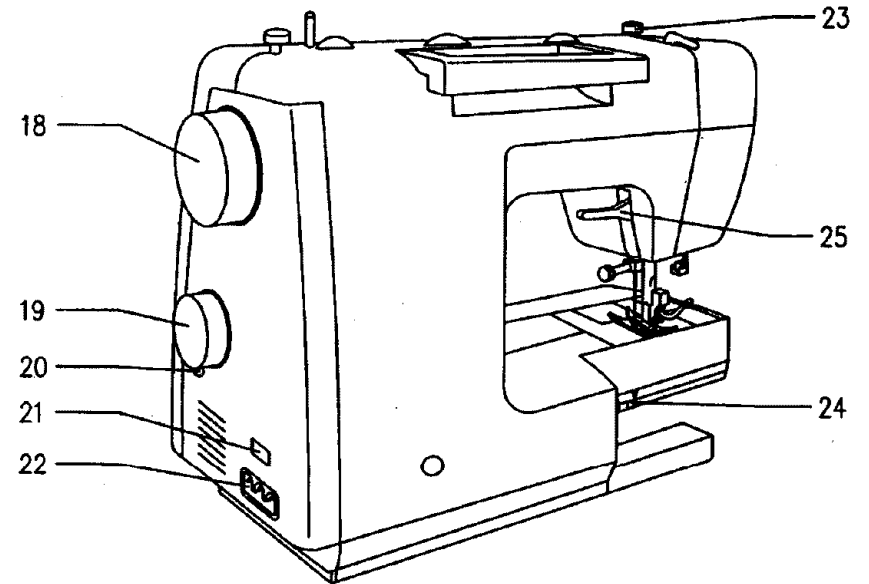

□ Accessories

Standard accessories Optional Accessories

- a. All purpose foot
- b. Zipper foot
- c. Buttonhole foot
- d. Button sewing foot
- e. Blind hem foot
- f. Seam ripper/brush
- g. Seam guide
- h. Pack of needles
- i. Spool holder
- j. Bobbin (3x)
- k. L-screwdriver

(These 9 accessories are not supplied with this machine; they are however available as special accessories from your local dealer.)

- l. Second spool pin
- m. Satin stitch foot
- n. Overcasting foot
- o. Hemmer foot
- p. Cording foot
- q. Darning foot
- r. Quilting foot
- s. Gathering foot
- t. Walking foot

Standard accessories

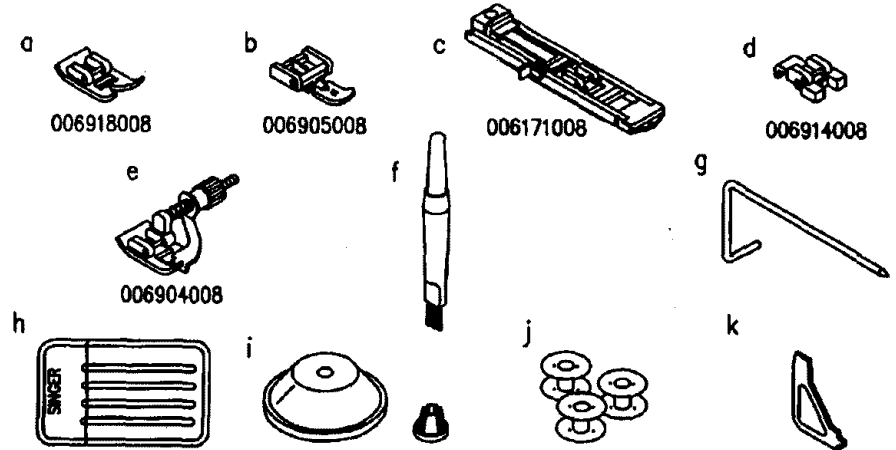

Optional accessories available at extra cost

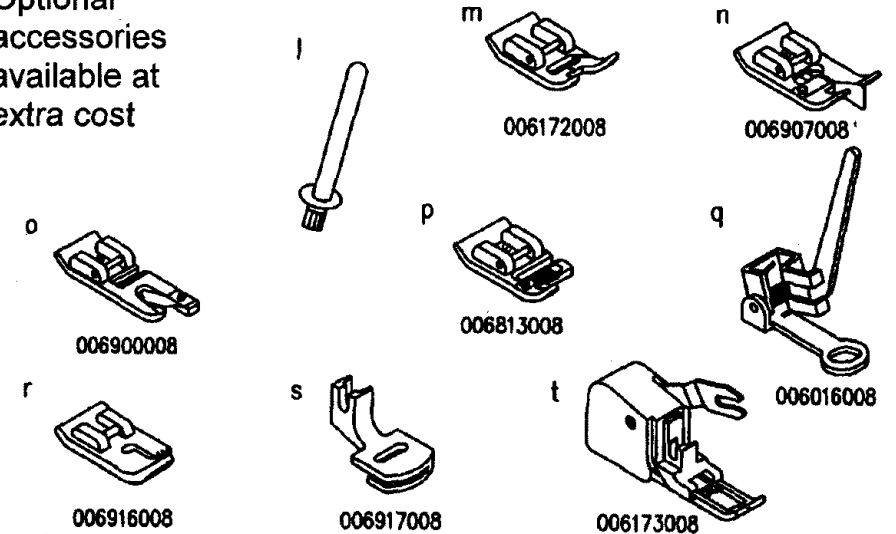

Installing the snap-in sewing table

Keep the snap-in sewing table horizontal, and push it in the direction of the arrow. (1)

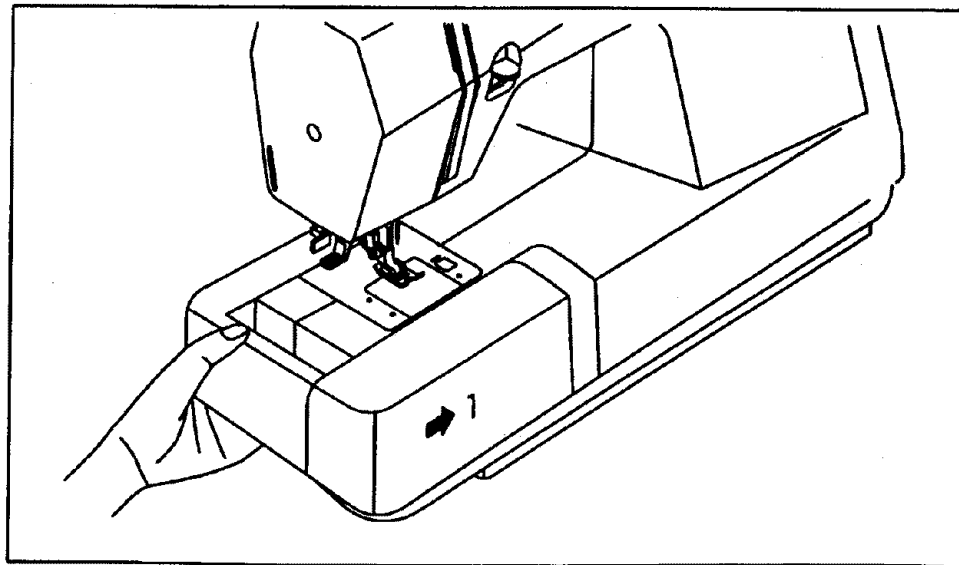

The inside of the snap-in sewing table can be utilized as an accessory box.

To open, lift up at the point of the arrow. (2)

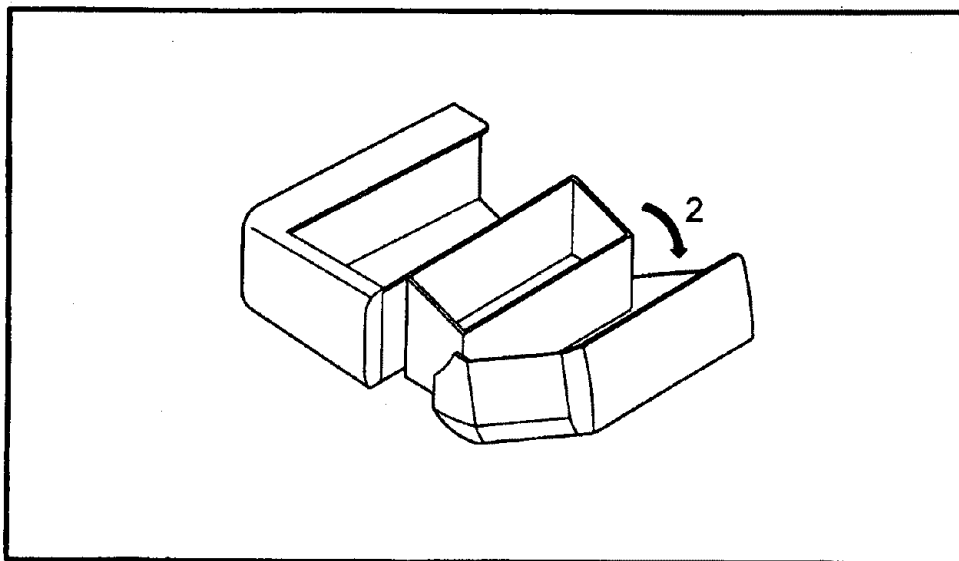

□ Connecting machine to power source

Connect the machine to a power source as illustrated. (1)
This appliance is equipped with a polarized plug which must be used with an appropriate polarized outlet. (2)

Attention:

Unplug power cord when machine is not in use.

Foot control

The foot control pedal regulates the sewing speed. (3)

Attention:

Consult a qualified electrician if in doubt as to connect machine to power source.

Unplug power cord when machine is not in use.

The foot control must be used with the appliance by 4C-316B (110-120V area) / 4C-126G or 4C-326G (230V area) 4C-316C or 4C-326C (220-240V area) manufactured by MATSUSHITA ELECTRIC (TAIWAN) CO., LTD.

Sewing light

Press main switch (4) for power and light on.

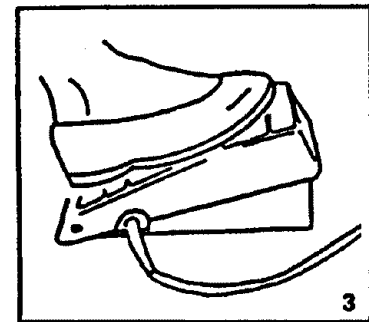
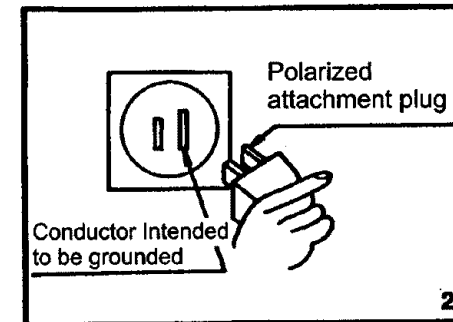
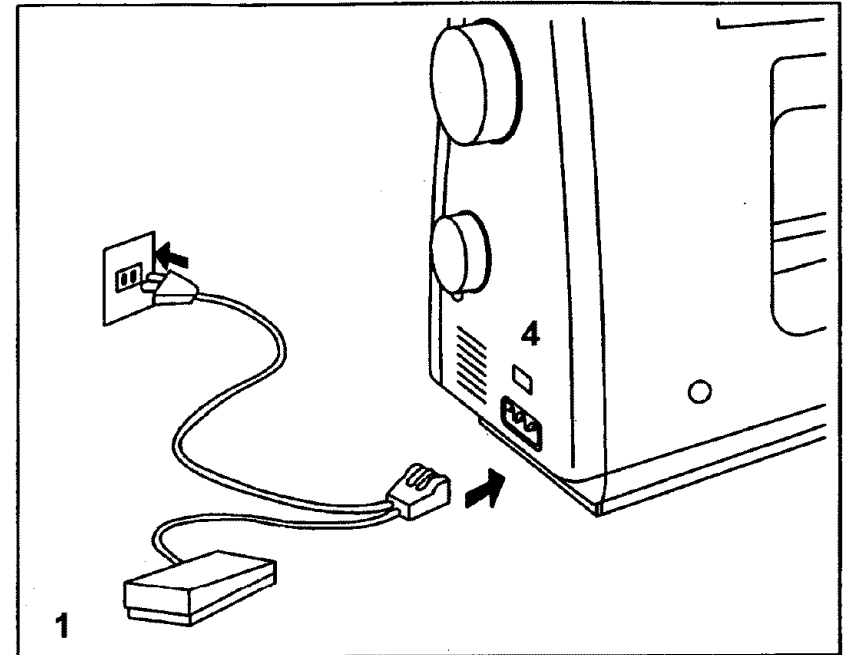

IMPORTANT NOTICE

This appliance has a polarized plug (one blade is wider than the other). To reduce the risk of electric shock, this plug will fit in a polarized outlet only one way. If the plug does not fit fully in the outlet, reverse the plug. If it still does not fit, contact a qualified electrician. Do not modify the plug in any way.

□ Changing the bulb

Disconnect the machine from the power supply by removing the plug from the main socket!

- Loosen screw (A) as illustrated.
- Remove the face plate (B).

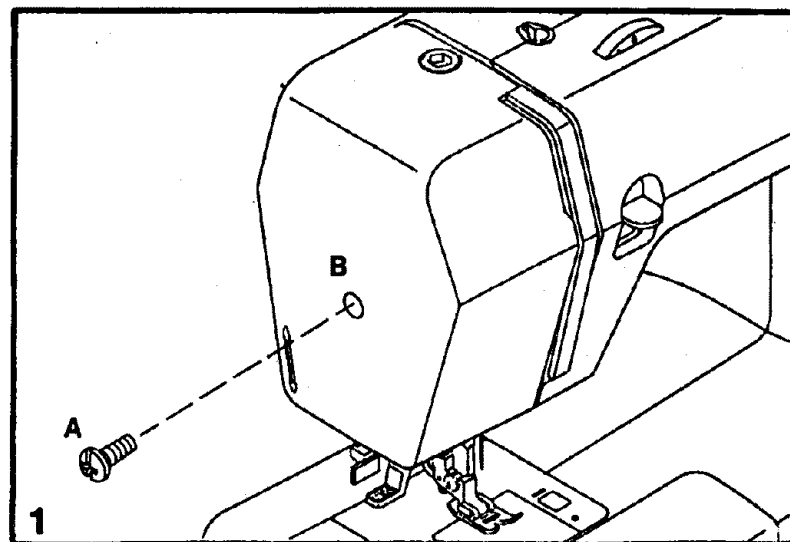

- Unscrew the bulb and install new one (C).
- Replace the face plate and tighten screw.

Should there be any problem, ask your local dealer for advice.

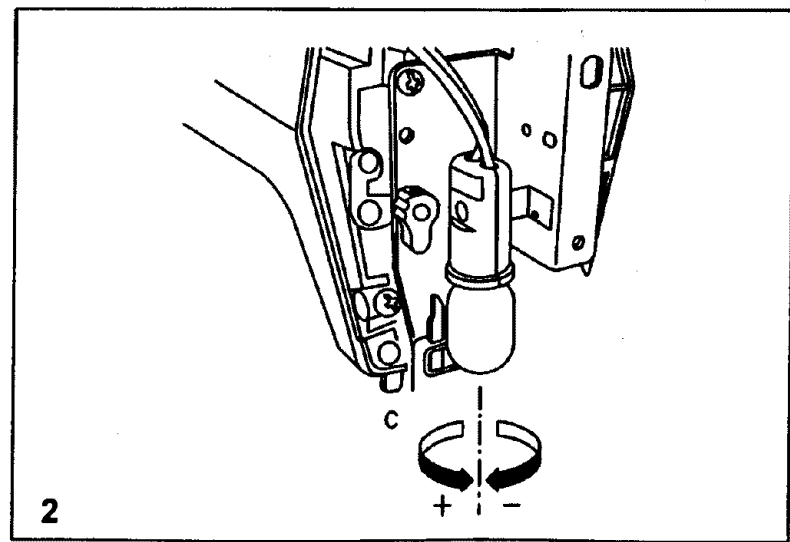

Two-step presser foot lifter

When sewing several layers of thick fabrics, the presser foot can be raised to a high rise position for easy positioning of the work (A).

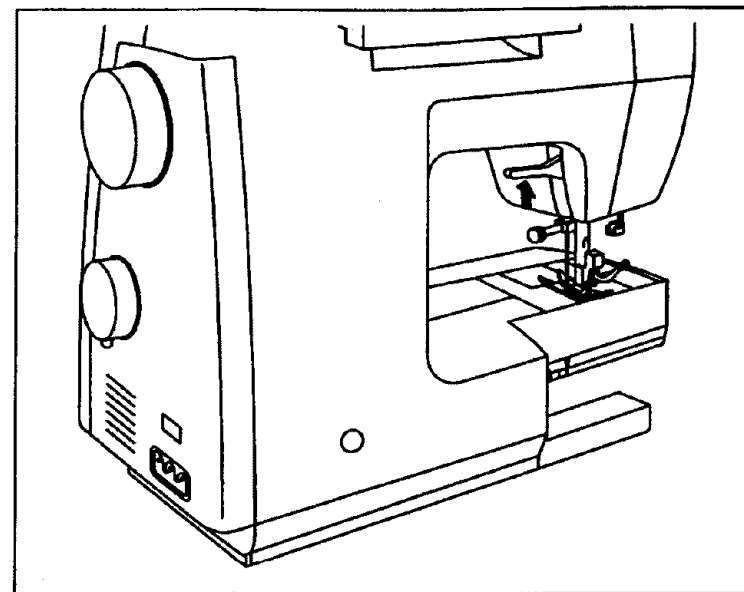

Adjusting presser foot pressure

The presser foot pressure of the machine has been pre-set at maximum pressure and requires no particular readjustment according to the type of fabric (light or heavy weight). However, if you need to adjust the presser foot pressure, turn the pressure adjusting screw with a coin. For sewing very thin fabric, loosen the pressure by turning the screw counterclockwise.

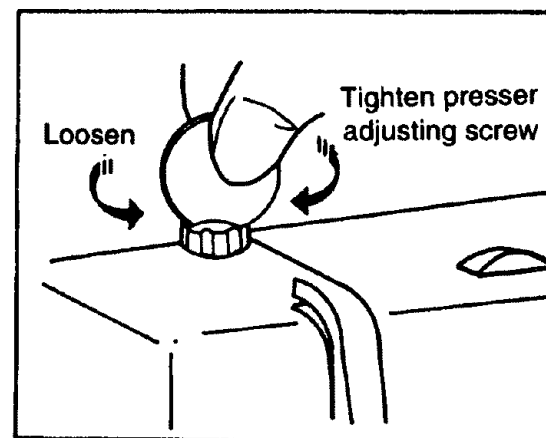

□ Attaching the presser foot holder

Raise the presser bar (a). Attach the presser foot holder (b) as illustrated.

Attaching the presser foot

Lower the presser foot holder (b) until the cut-out (c) is directly above the pin (d).

Raise the lever (e).

Lower the presser foot holder (b) and the presser foot (f) will engage automatically.

Removing the presser foot

Raise the presser foot.

Raise the lever (e) and the foot disengages.

Attaching the seam guide

Attach the seam guide (g) in the slot as illustrated. Adjust according to need for hems, pleats, etc.

Attention:

Turn power switch to "off" when carrying out any of the above operations!

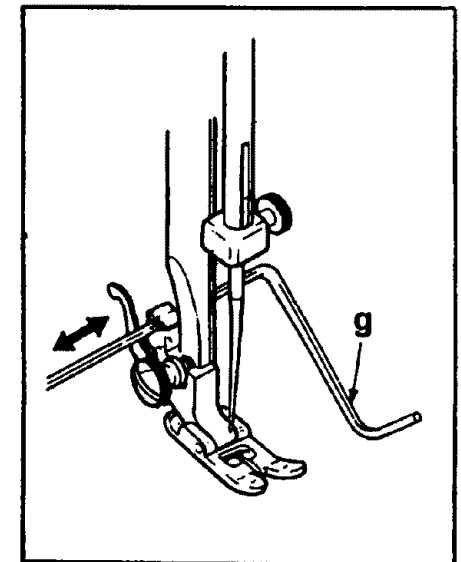
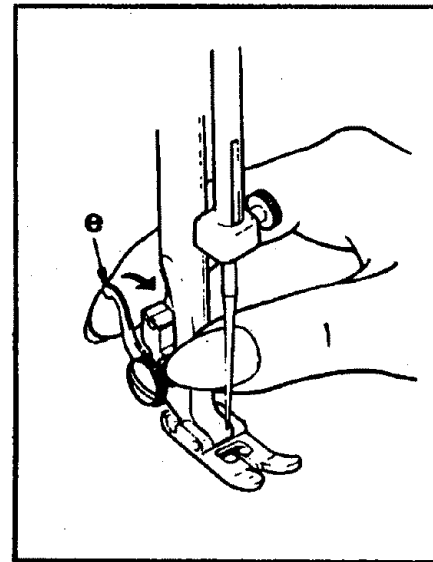
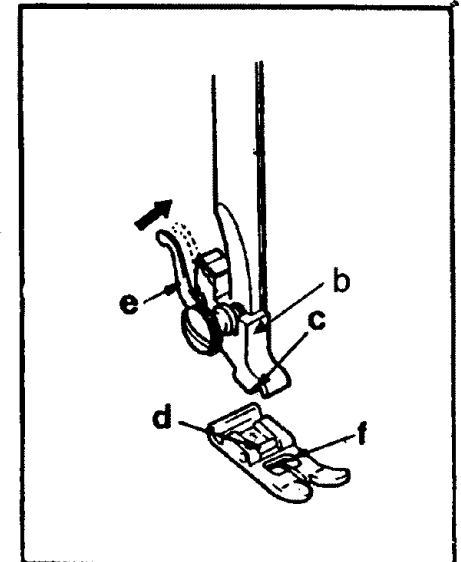
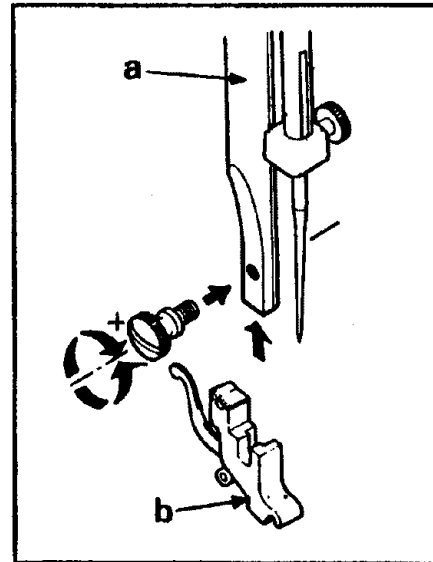

□ Winding the bobbin

Place thread and spool holder onto spool pin (1). For smaller spools of thread place spool holder with small side next to spool (2).

Snap thread into thread guide (3).

Wind thread clockwise around bobbin winder tension discs (4).

Thread bobbin as illustrated and place on spindle (5).

Push bobbin to right (6).

Hold thread end (7). Step on foot control pedal (8).

Cut thread (9). Press bobbin to left (10) and remove.

Please Note: When the bobbin winder spindle is in "bobbin winding" position, the machine will not sew and the hand wheel will not turn. To start sewing, push the bobbin winder spindle to the left (sewing position).

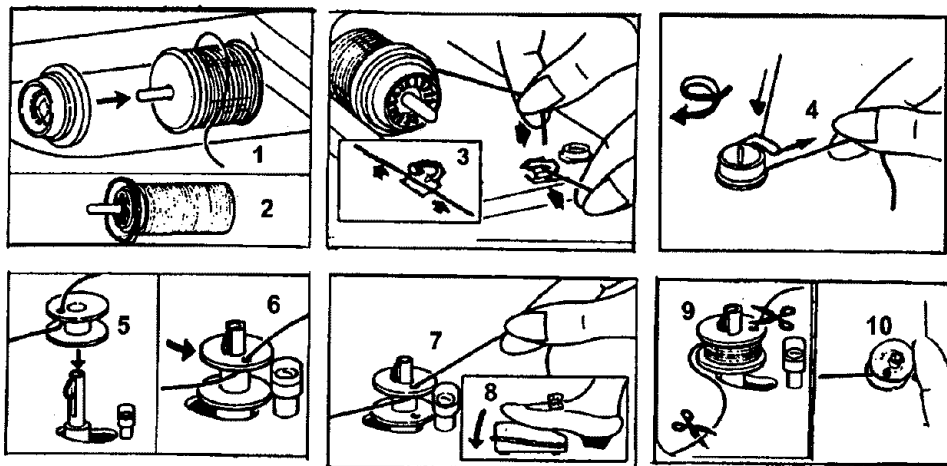
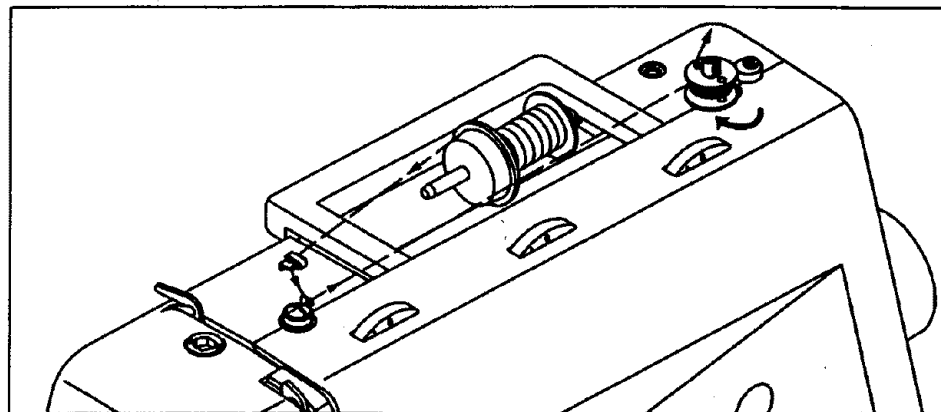

□ Inserting the bobbin

When inserting or removing the bobbin, the needle must be fully raised.

1. Insert the bobbin in the bobbin case with the thread running counterclockwise direction (arrow).
2. Pull the thread through the slit (A).
3. Draw the thread clockwise until it slips into the notch (B).
4. Pull out about 15 cm (6 inches) of thread and attach the bobbin cover plate (C).

Attention:

Turn power switch to "off" before inserting or removing the bobbin.

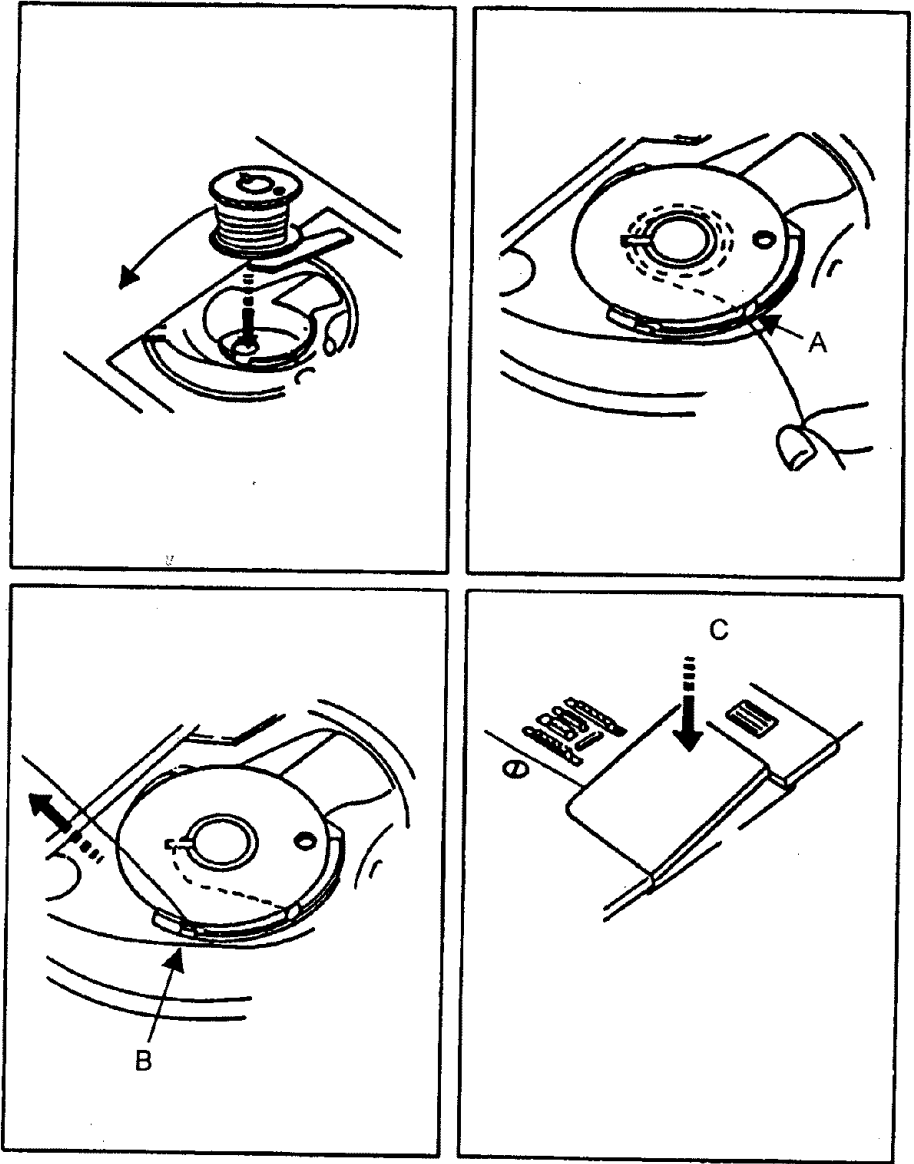

□ Inserting and changing needles

Change the needle regularly, especially if it is showing signs of wear and causing problems. For best sewing results always use Singer brand needles.

Insert the needle as illustrated as follows:

- Loosen the needle clamp screw and tighten again after inserting the new needle (A).
- The flat side of the shaft should be towards the back (B).
- Insert the needle as far up as it will go (C/D).

Attention:

Turn power switch to "off" before inserting or removing the needle.

Needles must be in perfect condition.

Problems can occur with:

- bent needles (a)
- blunt needles (b)
- damaged points (c)

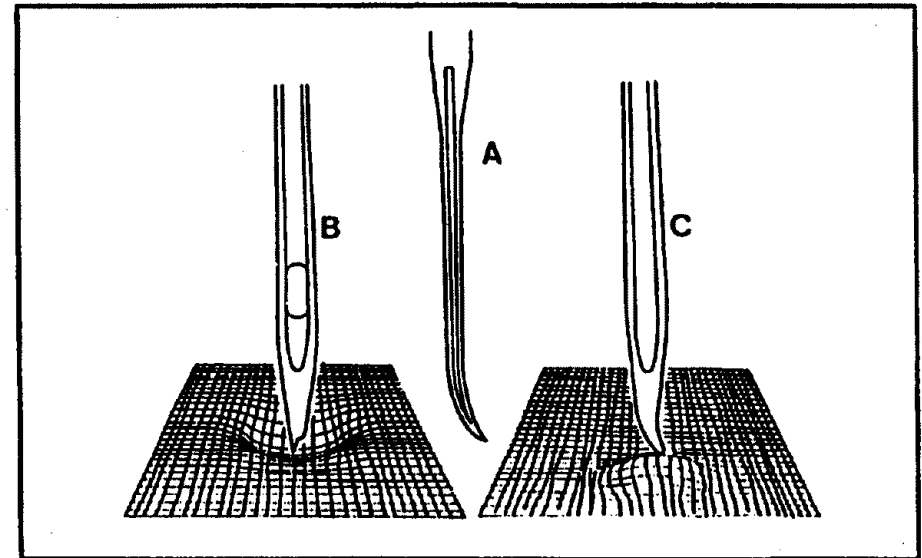
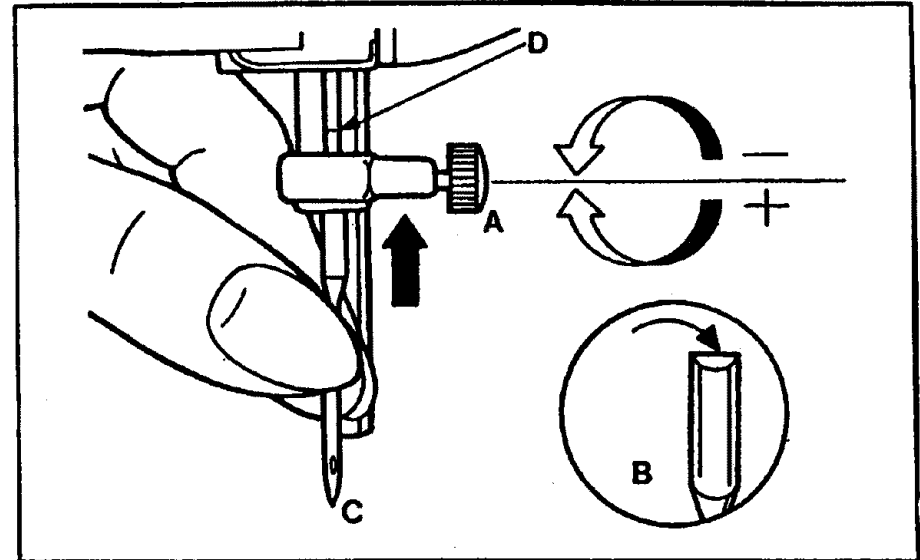

□ Threading the upper thread

This is a simple operation but it is important to carry out correctly as by not doing so several sewing problems could result.

- Start by raising the needle to its highest point (1), and also raise the presser foot to release the tension discs. (2)
Note: For safety, it is strongly suggested you turn off the power before threading.
- Lift up the spool pin. Place the spool of thread on the holder with the thread coming off the spool as shown. (3)
For small thread spools, place small side of spool holder next to spool.
- Draw thread from spool through the upper thread guide. (4)
- Guide thread around thread guide (5) pulling thread through pre-tension spring as illustrated.
- Thread tension module by leading thread down right channel and up left channel (6). During this process it is helpful to hold the thread between the spool and thread guide (4).
- At the top of this movement pass thread from right to left through the slotted eye of the take-up lever and then downwards again. (7)
- Pass thread behind the flat, horizontal thread guide. (8)
- Now take thread behind the thin wire needle clamp guide and then down to the needle which should be threaded from front to back. Pull about 6-8 inches of thread to the rear beyond the needle eye. (9)

Note: If your sewing machine is equipped with the factory installed optional automatic needle threader, instructions for use can be found on page 14.

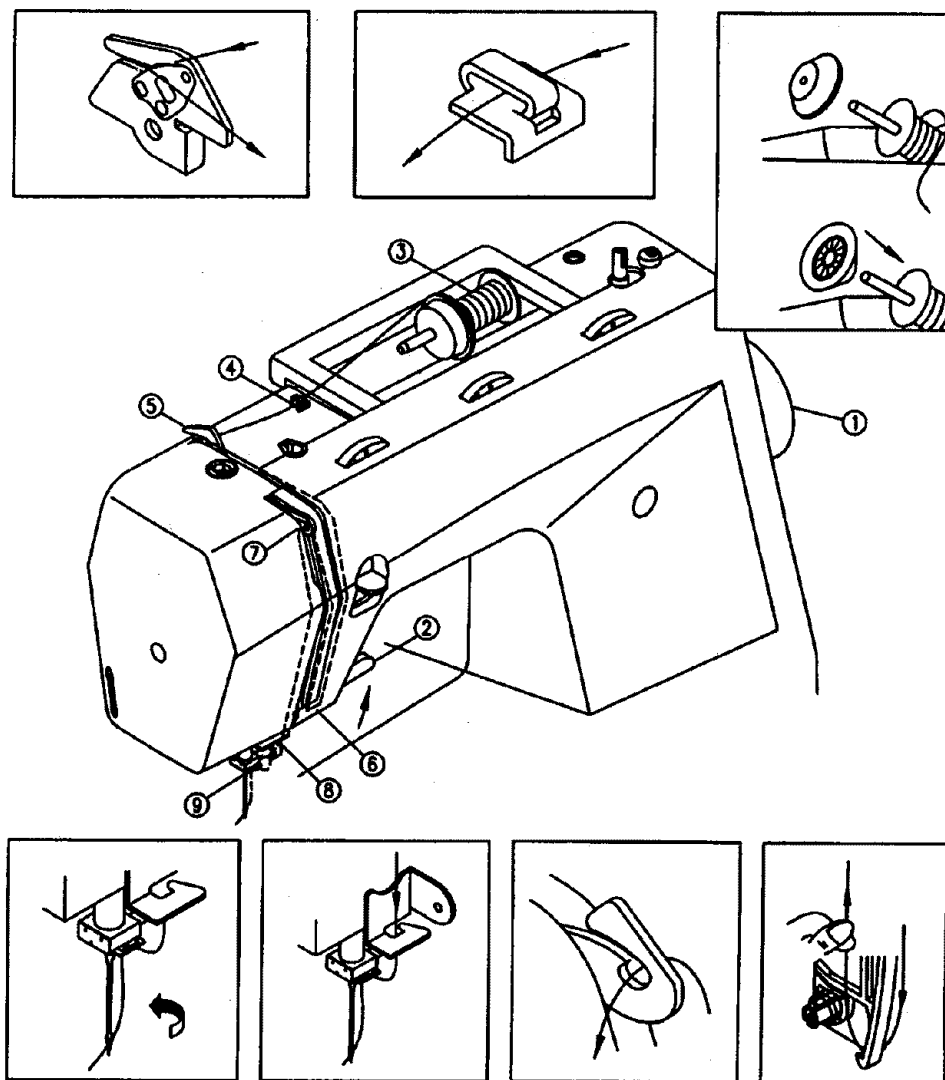

Optional automatic needle threader

* The Automatic Needle threader is a factory installed option. If your machine has this option use the following instructions:

- Raise the needle to its highest position
- Press lever (A) down as far as it will go
- The threader automatically swings to the threading position (B)
- Pass thread around thread guide (C)
- Pass the thread in front of the needle around the hook (D) from bottom to top
- Release lever (A)
- Pull the thread through the needle eye.

Attention:
Turn power switch to "0"!

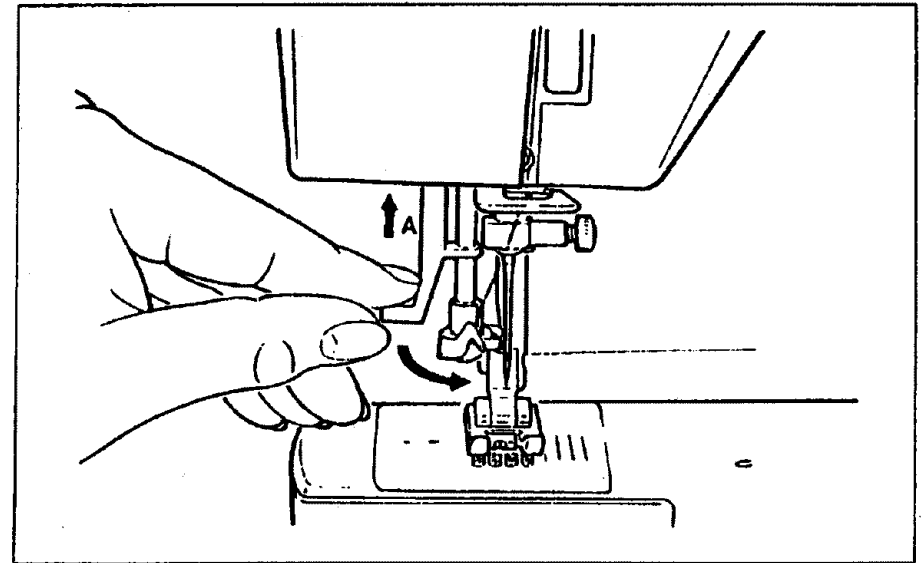
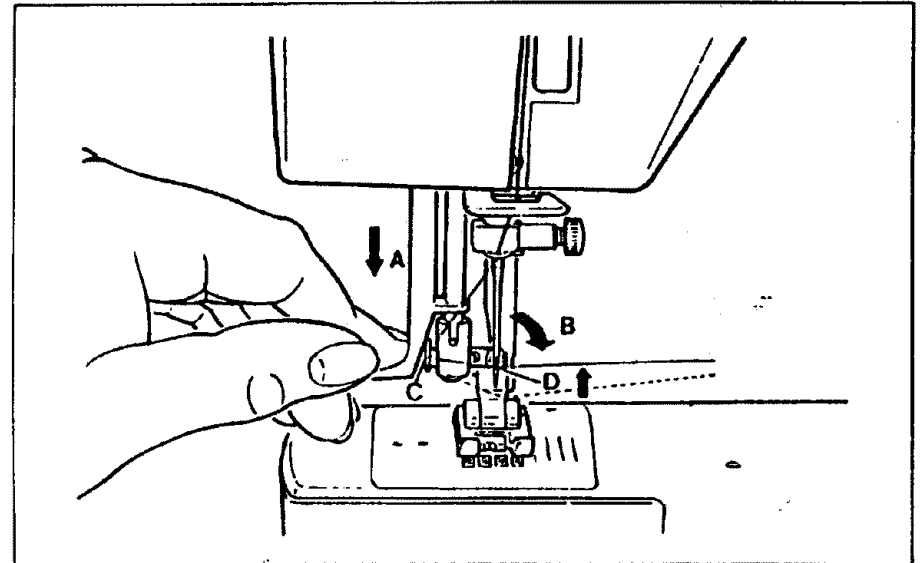

□ Thread tension

Upper thread tension

Basic thread tension setting: 4.

To increase the tension, turn the dial to the next number up.

To reduce the tension, turn the dial to the next number down.

- Normal thread tension for straight stitch sewing (A).
- Thread tension too loose for straight stitch sewing. Turn dial to higher number (B).
- Thread tension too tight for straight stitch sewing. Turn dial to lower number (C).
- Normal thread tension for zig zag and decorative sewing (D).

Please note:

- Proper setting of tension is important to good sewing.
- There is no single tension setting appropriate for all stitch functions, thread on fabric.
- A balanced tension (identical stitches both top and bottom) is usually only desirable for straight stitch construction sewing.
- 90% of all sewing will be between 3 and 5 (4 is basic setting).
- For zig zag and decorative sewing stitch functions, thread tension should generally be less than for straight stitch sewing.
- For all decorative sewing you will always obtain a nicer stitch and less fabric puckering when the upper thread appears on the bottom side of your fabric.

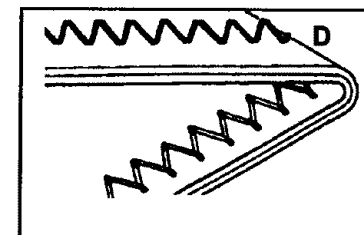
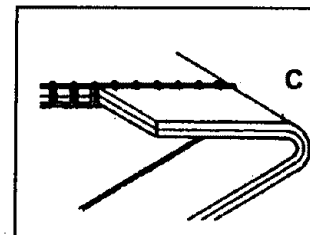
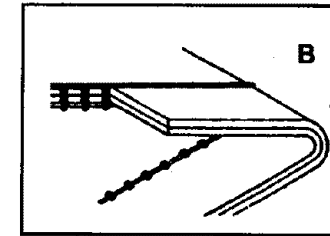
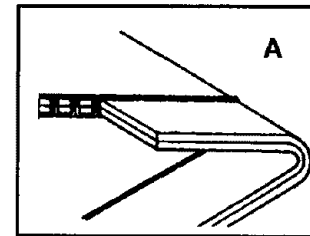
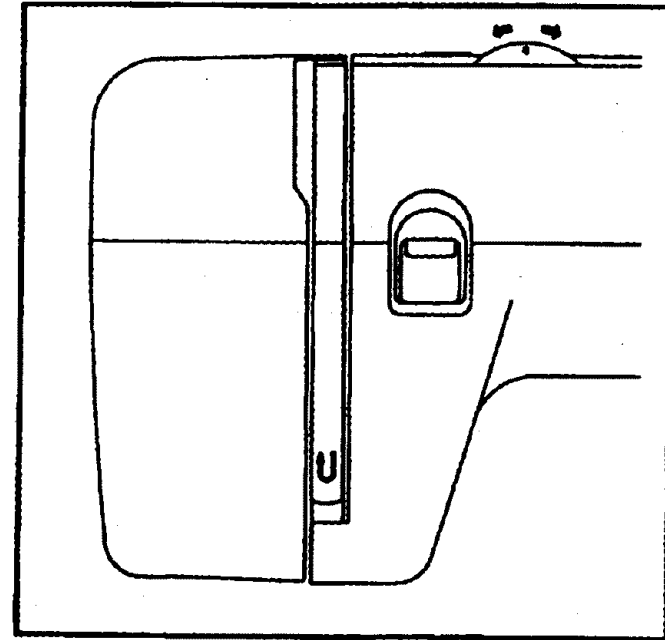

Raising the bobbin thread

Hold the upper thread with the left hand. Turn the handwheel (1) towards you (counterclockwise) lowering, then raising needle.

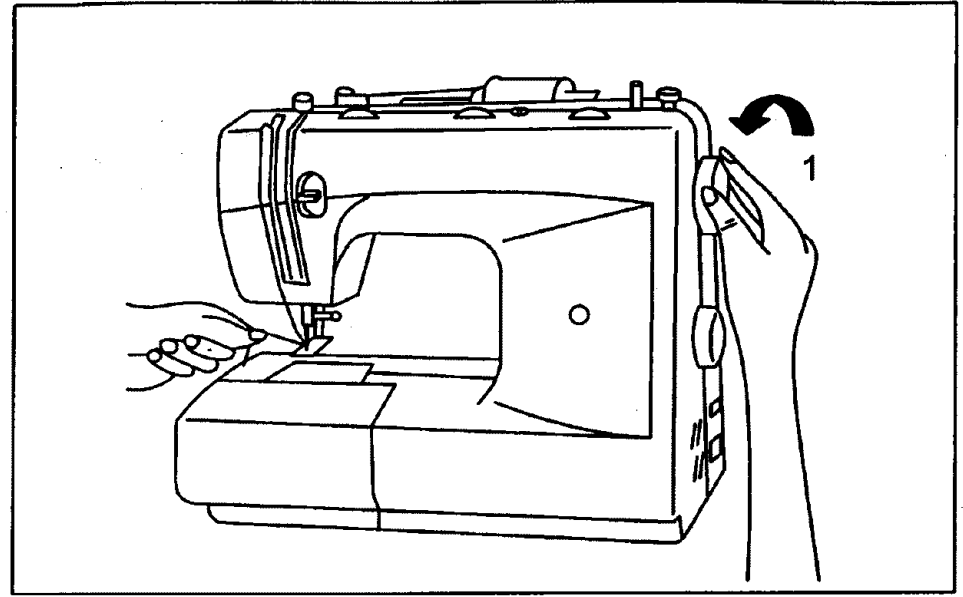

Gently pull on the upper thread to bring the bobbin thread up through the needle plate hole (2). Lay both threads to the back under the presser foot. (3)

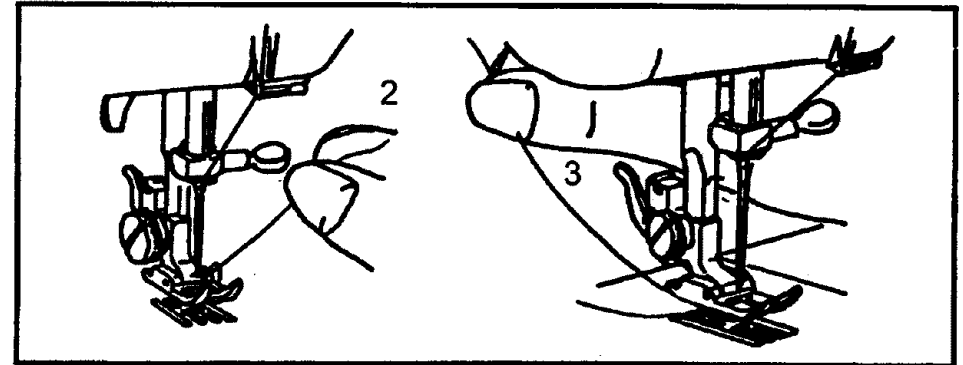

Reverse sewing

To secure the beginning and end of seam, press down the reverse sewing lever. Sew a few reverse stitches. Release the lever and the machine will sew forwards again (A).

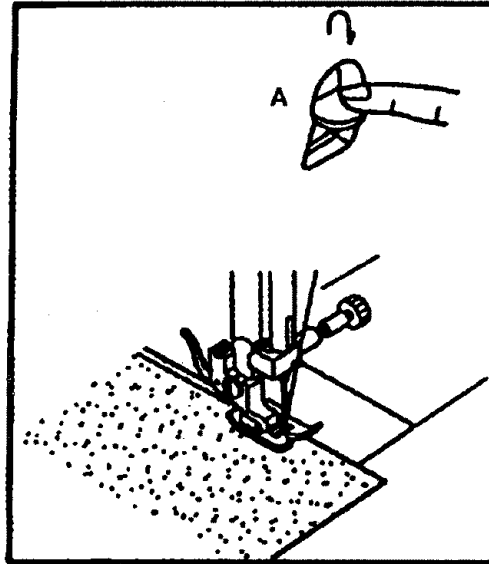

Removing the work

Turn the handwheel counter clockwise to bring the thread take up lever to its highest position, raise the presser foot and remove work behind the presser foot and needle.

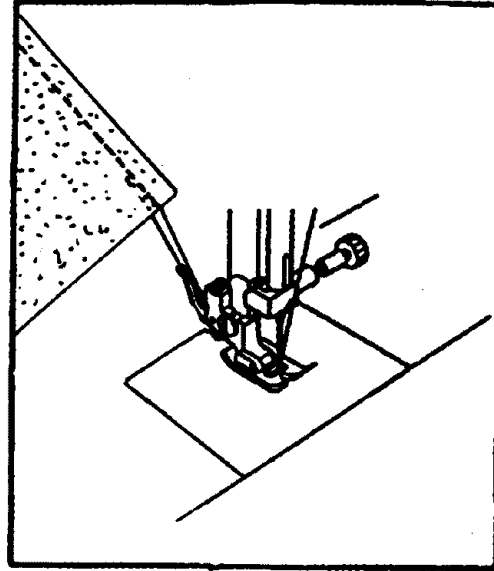

Cutting the thread

Cutting the thread:
Pull the threads behind the presser foot. Guide the threads to the side of the face plate and into thread cutter (B). Pull threads down to cut.

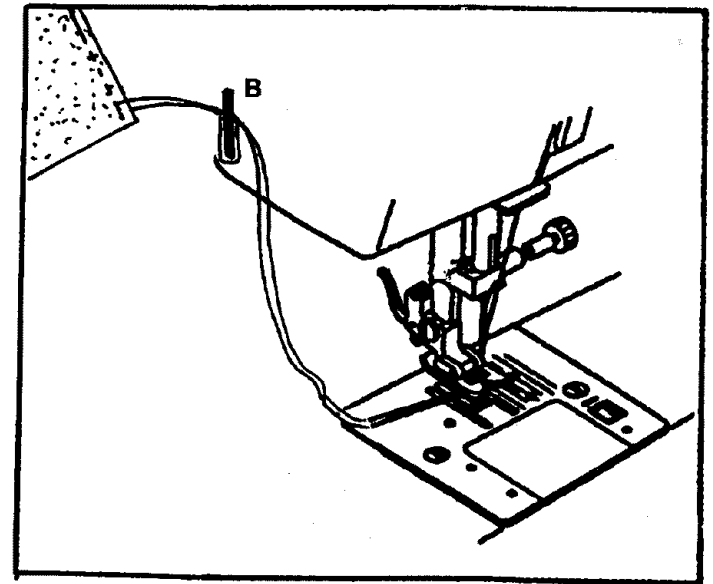

Matching needle/fabric/thread

NEEDLE, FABRIC, THREAD SELECTION GUIDE

NEEDLE SIZE	FABRICS	THREAD
9-11 (70-80)	Lightweight fabrics-thin cottons, voile, serge, silk, muslin, Qiana, interlocks, cotton knits, tricots, jerseys, crepes, woven polyester, shirt & blouse fabrics.	Light-duty thread in cotton, nylon, polyester or cotton wrapped polyester.
11-14 (80-90)	Medium weight fabrics-cotton, satin, kettleciath, sailcloth, double knits, lightweight woollens.	Most threads sold are medium size and suitable for these fabrics and needle sizes. Use polyester threads on synthetic materials and cotton on natural woven fabrics for best results. Always use the same thread on top and bottom.
14 (90)	Medium weight fabrics-cotton duck, woolen, heavier knits, terrycloth, denims.	
16 (100)	Heavyweight fabrics-canvas, woollens, outdoor tent and quilted fabrics, denims, upholstery material (light to medium).	
18 (110)	Heavy woollens, overcoat fabrics, upholstery fabrics, some leathers and vinyls.	Heavy duty thread, carpet thread. (Use heavy foot pressure- large numbers.)

IMPORTANT Match needle size to thread size and weight of fabric.



NEEDLE, FABRIC SELECTION

NEEDLES	EXPLANATION	TYPE OF FABRIC
SINGER 2020	Standard sharp needles. Sizes range thin to large. 9 (70) to 18 (110)	Natural woven fabrics-wool, cotton, silk, etc. Qiana. Not recommended for doubleknits.
SINGER 2045	Semi-ball point needle, scarfed. 9 (65) to 18 (110)	Natural and synthetic woven fabrics, polyester blends. Knits-polyesters, interlocks, tricots, single and double knits. Also sweater knits, Lycra, swimsuit fabric, elastic.
SINGER 2025	Twin needle	Woven fabrics and knits.
SINGER 2032	Leather needles. 12 (80) to 18 (110)	Leather, vinyl, upholstery. (Leaves smaller hole than standard large needle.)

Note:

1. Twin needles, can be purchased for utility and decorative work.
2. When sewing with twin needles, the stitch width dial should be set at less than 4.
3. For best sewing results, use only Genuine Singer needles.
4. Replace needle often (approximately every other garment) and / or at first thread breakage or skipped stitches.

□ How to choose your pattern (For 2 dial model)

For center needle **straight stitch** select pattern () with pattern selector dial. Adjust the stitch length with the stitch length dial. You may choose left needle position, by selecting pattern ()

For **zigzag stitch**, select pattern () with pattern selector dial. Adjust the stitch length according to the fabric being used.

To obtain any of the other **patterns shown** on the stitch selection panel, select the stitch with the pattern selector dial. Adjust the stitch length with the stitch length dial.

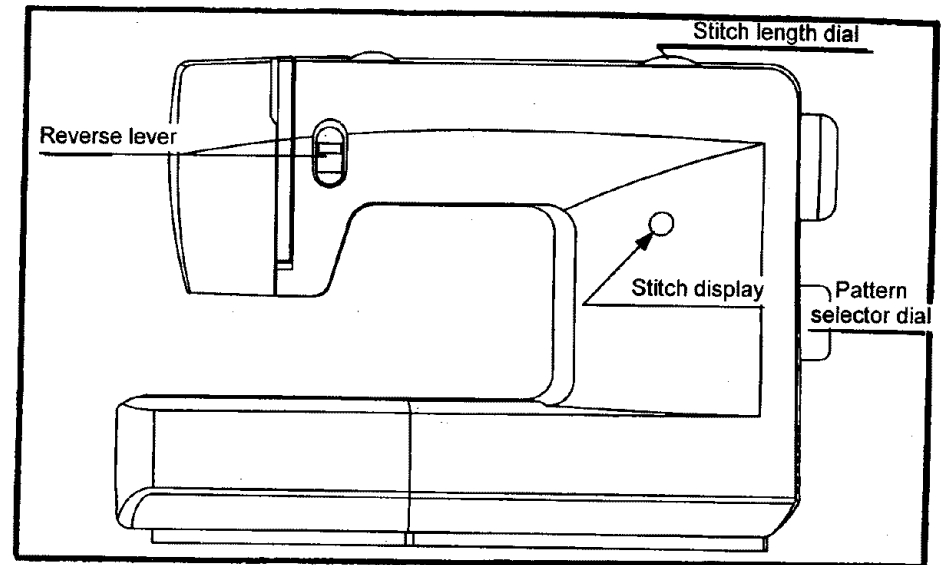

Note: If your machine has these stitch patterns, it will be referred to as "2 dial model" throughout this Instruction Book.

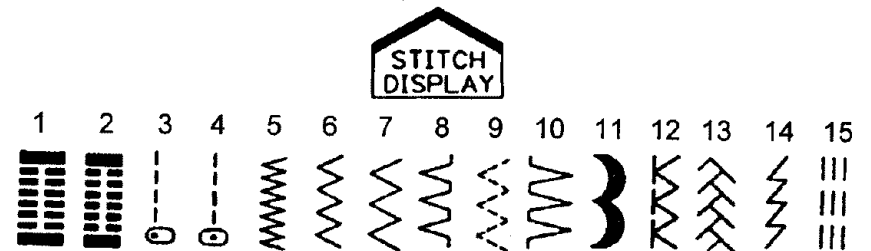

□ How to choose your pattern (For 3 dial 20 stitch model)

For **straight stitch** select pattern (1) with pattern selector dial. Adjust the stitch length with the stitch length dial. You may choose any needle position, by turning the stitch width dial.

For **zigzag stitch**, select pattern (3) with pattern selector dial. Adjust the stitch length according to the fabric being used.

To obtain any of the other **patterns shown** on the stitch selection panel, select the stitch with the pattern selector dial. Adjust the stitch length and stitch width with the respective dials.

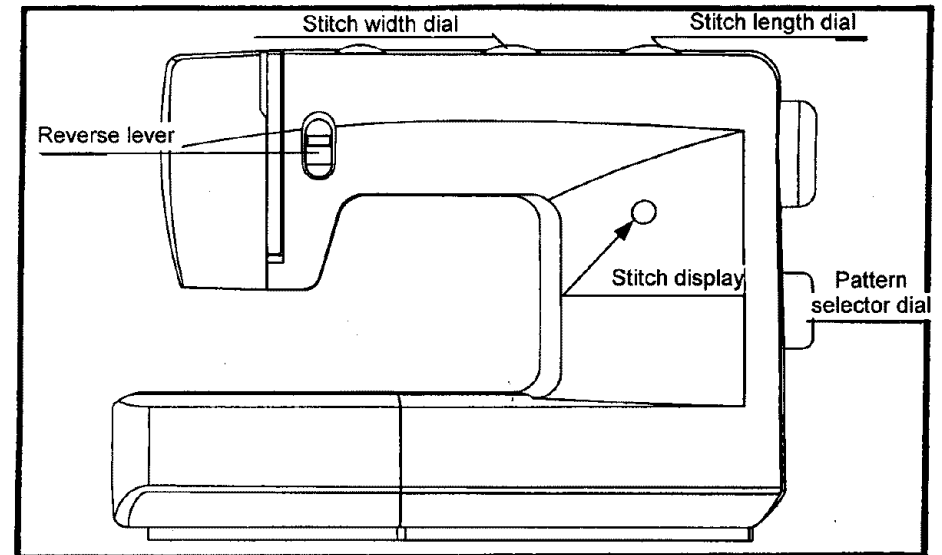

Note: If your machine has these stitch patterns, it will be referred to as a "3 dial 20 stitch model" throughout this Instruction book.

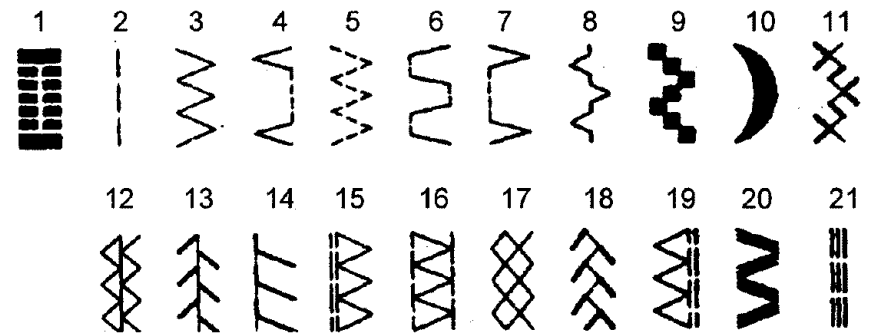

□ How to choose your pattern (For 3 dial 25 stitch model)

For **straight stitch** select pattern (A) with pattern selector dial. Adjust the stitch length with the stitch length dial. You may choose any needle position, by turning the stitch width dial.

For **zigzag stitch**, select pattern (B) with pattern selector dial. Adjust the stitch length and stitch width according to the fabric being used.

To obtain any of the other **patterns shown in the upper row** on the stitch selection panel, select the letter above the stitch with the pattern selector dial. Adjust the stitch length and the stitch width with the control dials according to the result desired.

To obtain any of the **patterns on the second row**, turn the stitch length dial to (S), select the pattern desired with pattern selector dial, and adjust the stitch width with the stitch width dial.

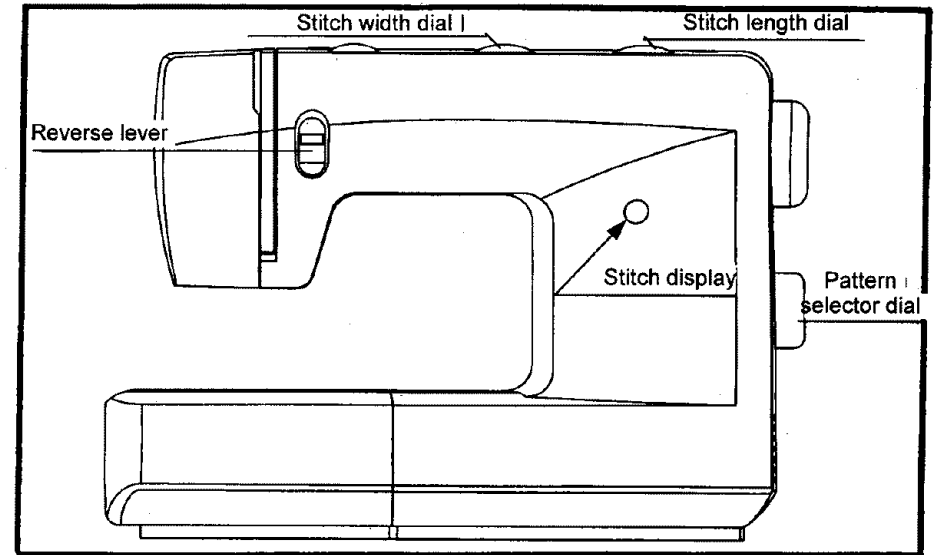

Note: If your machine has these stitch patterns, it will be referred to as a "3 dial 25 stitch model" throughout this Instruction book.

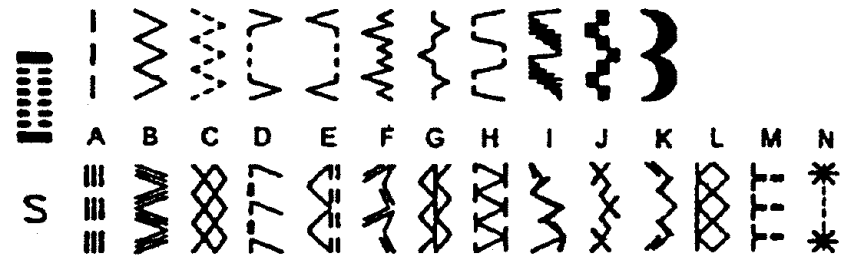

Straight stitching and needle position (For 2 dial model)

Turn the stitch selection dial so that the stitch display shows the straight stitch position. (|)

Generally speaking, the thicker the fabric, thread and needle, the longer the stitch should be.



Straight stitches

- Choose your needle position, from center needle position or left needle position.

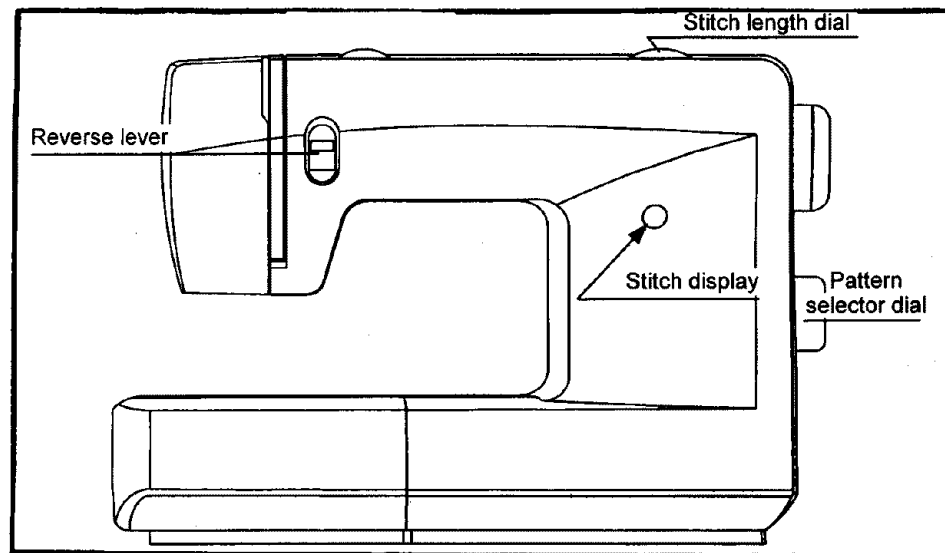

□ Straight stitching and needle position (For 3 dial models)

Turn the Pattern selector dial so that the stitch display shows the straight stitch position. (i) (For 20 stitch pattern model)

Turn the Pattern selector dial so that the stitch display shows (A) (for 25 stitch model).

Generally speaking, the thicker the fabric, thread and needle, the longer the stitch should be.

S
| III
| III
| III
| III
| III

Straight stitches

- Choose your needle position, from center position to left needle position by changing the stitch width dial from "0" to "7".

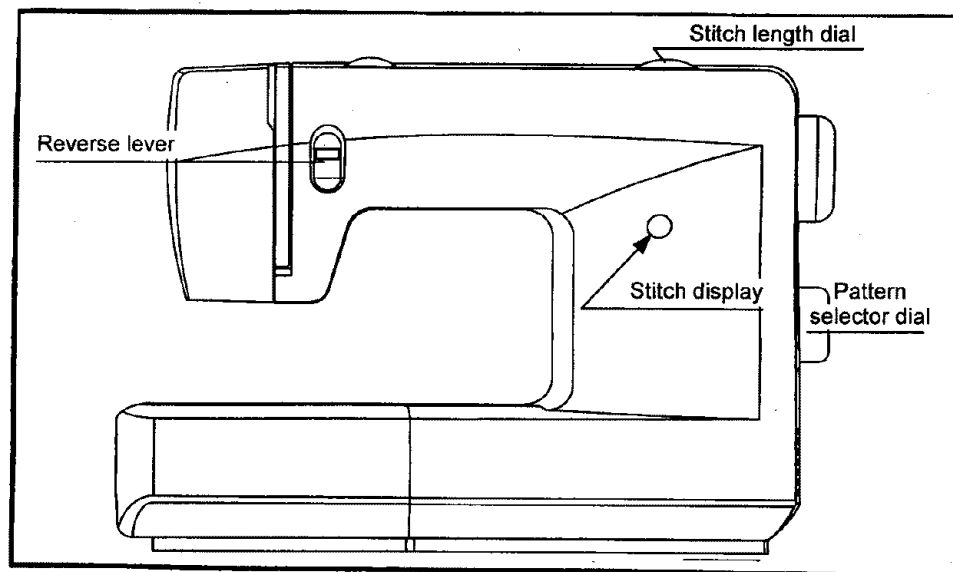

Zigzag stitching (For 2 dial model)

Turn the pattern selector dial so that the stitch display shows "zig-zag" (👉👈). Turning the pattern selector dial will increase or decrease the zig zag width (illustration 1).

Function of stitch length dial while zigzaging

The density of zigzag stitches increase as the setting of stitch length dial approaches "0".

Neat zigzag stitches are usually achieved at "2.5" or below. Closed up zigzag stitches (close together) are referred to as a satin stitch (illustration 2).

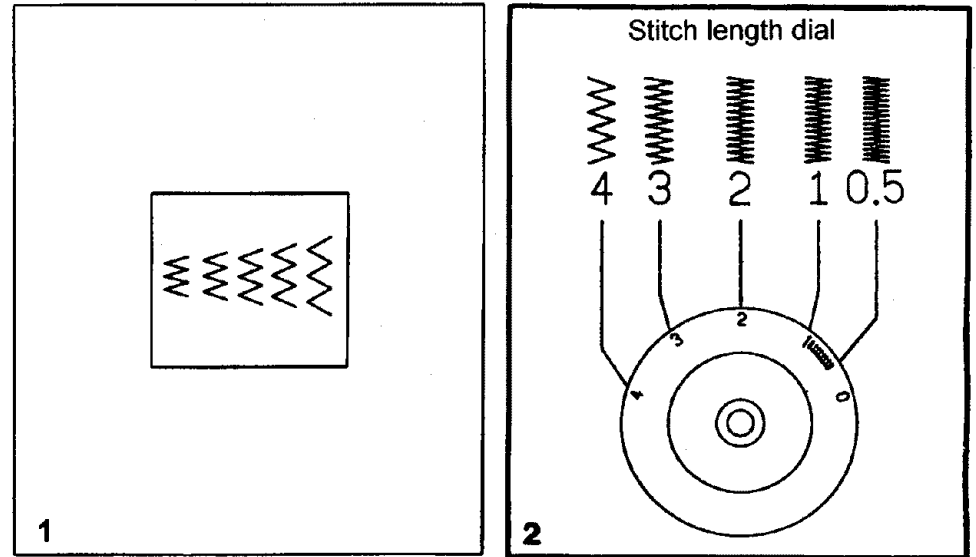

□ Zigzag stitching (For 3 dial models)

Turn the pattern selector dial to () (For 20 stitch patterns).
Turn the pattern selector dial to (B) (For 25 stitch pattern model).

Function of stitch width dial

The maximum zigzag stitch width for zigzag stitching is "7"; however, the width can be reduced on any pattern. The width increases as you move zigzag dial from "0" - "7". For twin needle sewing, never set the width wider than "4". (illustration 1)

Function of stitch length dial while zigzaging

The density of zigzag stitches increase as the setting of stitch length dial approaches "0".
Neat zigzag stitches are usually achieved at "2.5" or below.

Closed up zigzag stitches (close together) are referred to as a satin stitch. (illustration 2)

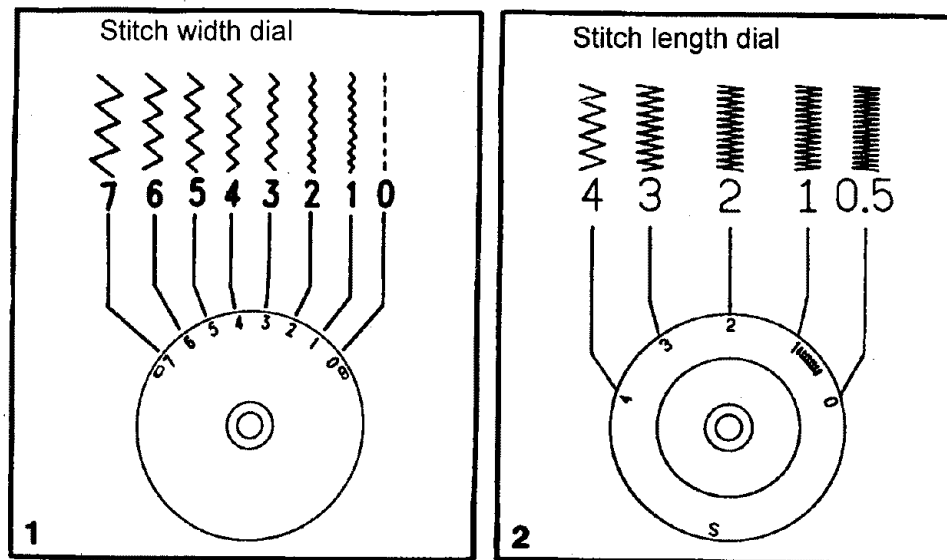

□ Blind hem/lingerie stitch (For 3 dial models)

For hems, curtains, trousers, skirts, etc.

Λ...Λ Blind hem for stretch fabrics position "F" on pattern selector dial (25 stitch pattern model).

Λ...Λ Blind hem/lingerie for firm fabrics position Λ...Λ on pattern selector dial (20 stitch pattern model) and position "E" on pattern selector dial (25 stitch pattern model).

Set the machine as illustrated (1).

Note:

For 2 dial model use pattern 8 (see page 22).

It takes practice to sew blind hems. Always make a sewing test first.

Fold the fabric as illustrated with the wrong side uppermost (2).

Place the fabric under the foot. Turn the handwheel forwards by hand until the needle swings fully to the left. It should just pierce the fold of the fabric. If it does not, adjust the stitch width accordingly (3).

Adjust the guide (4) by turning the knob (5) so that the guide just rests against the fold.

Sew slowly, guiding the fabric carefully along the edge of the guide.

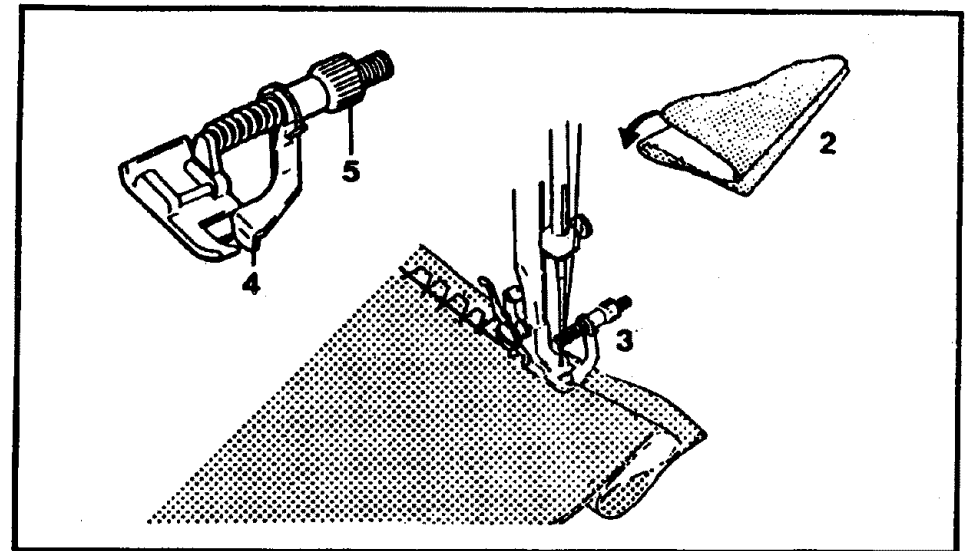
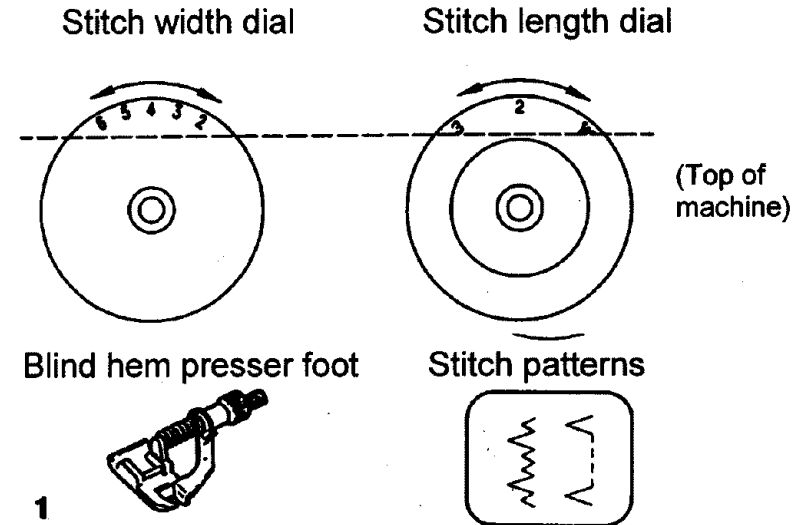

Overlock stitches (For 2 dial model)

Seams, overcasting, visible hems.

Standard overlock:  Position on pattern selector dial.

For fine knits, jerseys, neck edges, ribbing.

All overlock stitches are suitable for sewing and overcasting edges and visible seams in one operation.

When overcasting the needle should just go over the edge of the fabric.

Attention:

Use new needles or ball point needles to avoid skipping.

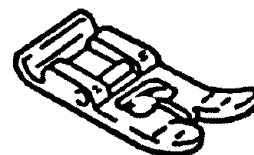

All purpose foot

Stitch length dial

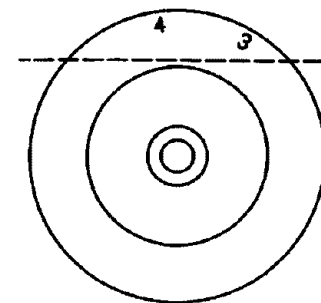

Optional overcasting foot
(Available from your local dealer)

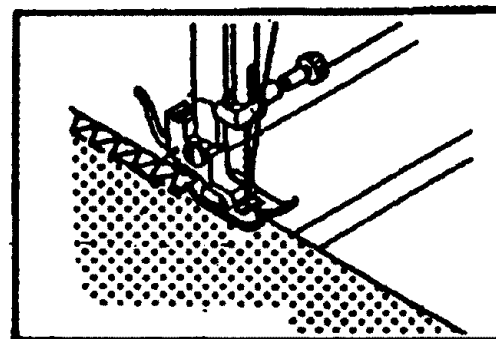
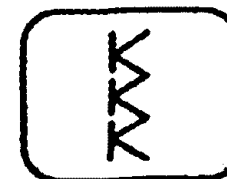

□ Overlock stitches (For 3 dial 20 stitch model)

Seams, overcasting, visible hems.

Turn stitch length dial to S.

The stitch width can be adjusted to suit the fabric.

Standard overlock (A)  **Position on pattern selector dial.**

For fine knits, jerseys, neck edges, ribbing.

Double overlock stitch (B)  **Position on pattern selector dial.**

For fine knits, handknits, seams.

Stretch overlock (C)  **Position on pattern selector dial.**

For fine knits, jerseys, neck edges, ribbing.

All overlock stitches are suitable for sewing and overcasting edges and visible seams in one operation.

When overcasting, the needle should just go over the edge of the fabric.

Attention:

Use new needles or ball point needles to avoid skipping.

Stitch width dial

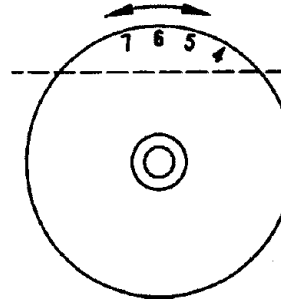

Stitch length dial

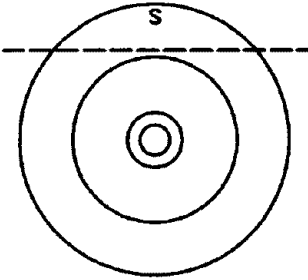

All purpose foot

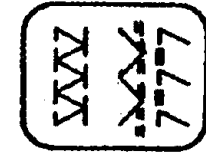

Optional overcasting foot
(Available from your local dealer)

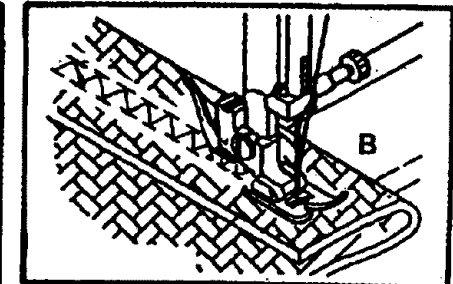
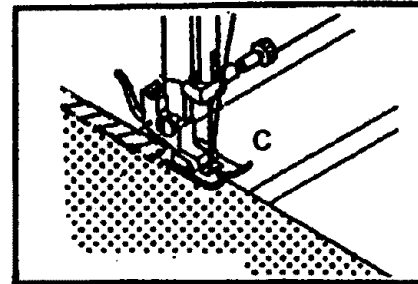
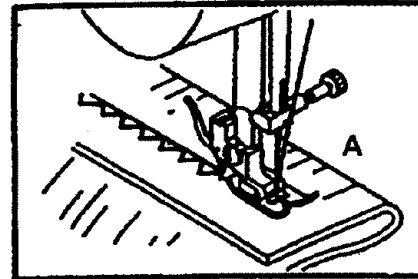

□ Overlock stitches (For 3 dial 25 stitch model)

Seams, overcasting, visible hems.

Turn stitch length dial to S.

The stitch width can be adjusted to suit the fabric.

Standard overlock:  Position "E" on pattern selector dial.

For fine knits, jerseys, neck edges, ribbing.

Double overlock stitch  Position "H" on pattern selector dial.

For fine knits, handknits, seams.

Stretch overlock  Position "D" on pattern selector dial.

For fine knits, jerseys, neck edges, ribbing.

All overlock stitches are suitable for sewing and overcasting edges and visible seams in one operation.

When overcasting, the needle should just go over the edge of the fabric.

Attention:

Use new needles or ball point needles to avoid skipping.

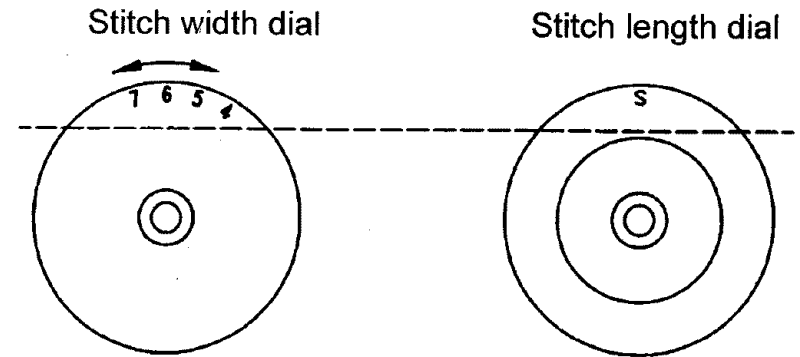

All purpose foot

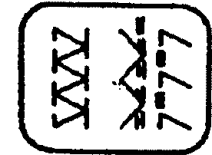

Optional overcasting foot
(Available from your local dealer)

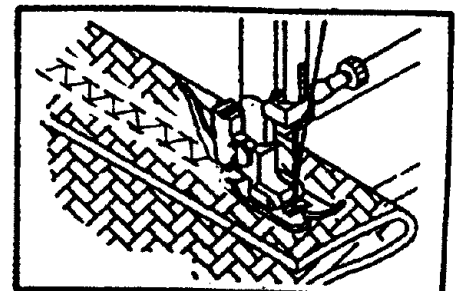
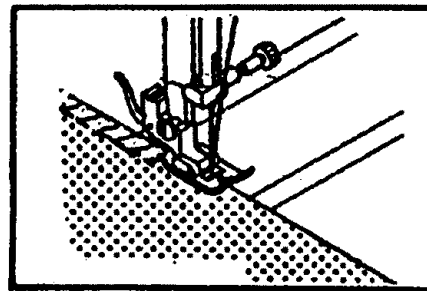
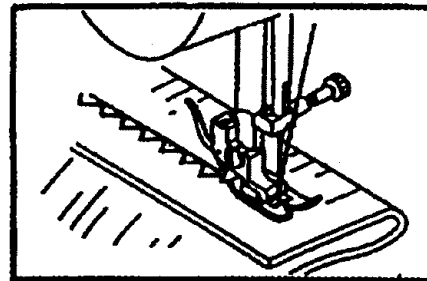

Sewing on buttons (For 2 dial model)

Move the drop feed control to right side to lower the feed dogs.

Change presser foot to button sewing foot (1).

Position the work under the foot. Place the button in the desired position and lower the foot. Set the pattern selector knob on Φ and sew a few securing stitches. Select one of the two narrow zig zag patterns according to the distance between the two holes of the button. Turn the handwheel to check if the needle goes into the right and the left hole of the button without hitting the button.

Slowly sew on the button with about 10 stitches. Select pattern Φ and sew a few securing stitches (2).

If a shank is required, place a darning needle on top of the button and sew (3). For buttons with 4 holes, sew through the front two holes first (2), push the work forward and then sew through the back two holes (3).

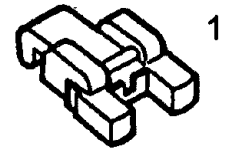

Button sewing foot

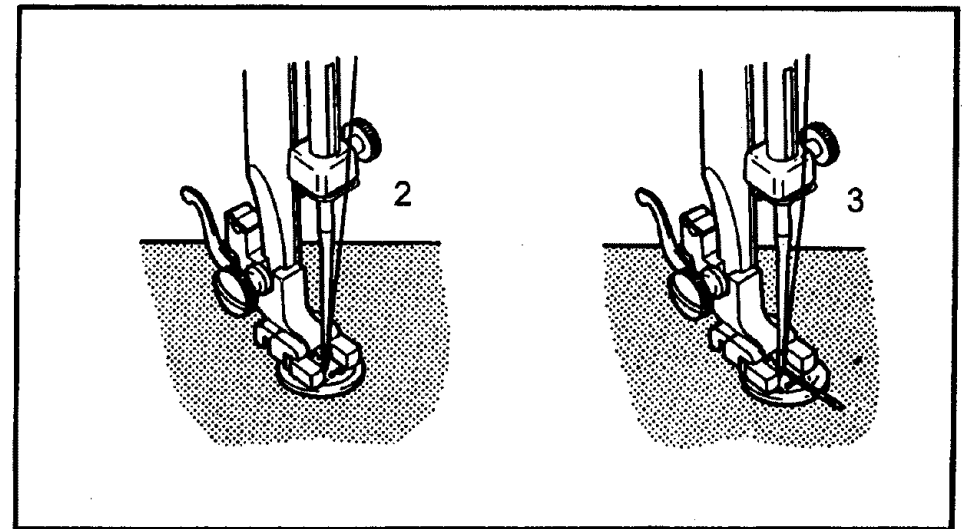

□ Sewing on buttons (For 3 dial models)

Move the drop feed control to right side to lower the feed dogs.

Change presser foot to button sewing foot (1). Select zig zag pattern ().

Position the work under the foot. Place the button in the desired position, lower the foot, adjust stitch width to "0" and sew a few securing stitches. Adjust the stitch width to "3". Turn the handwheel to check that the needle goes cleanly into the left and right holes of the button (adjust the stitch width according to the button), and slowly sew on the button with about 10 stitches. Adjust the stitch width to "0" and sew a few securing stitches (2).

If a shank is required, place a darning needle on top of the button and sew (3). For buttons with 4 holes, sew through the front two holes first (2), push work forward and then sew through the back two holes (3).

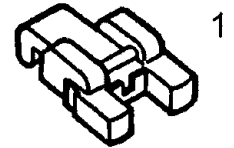

Button sewing foot

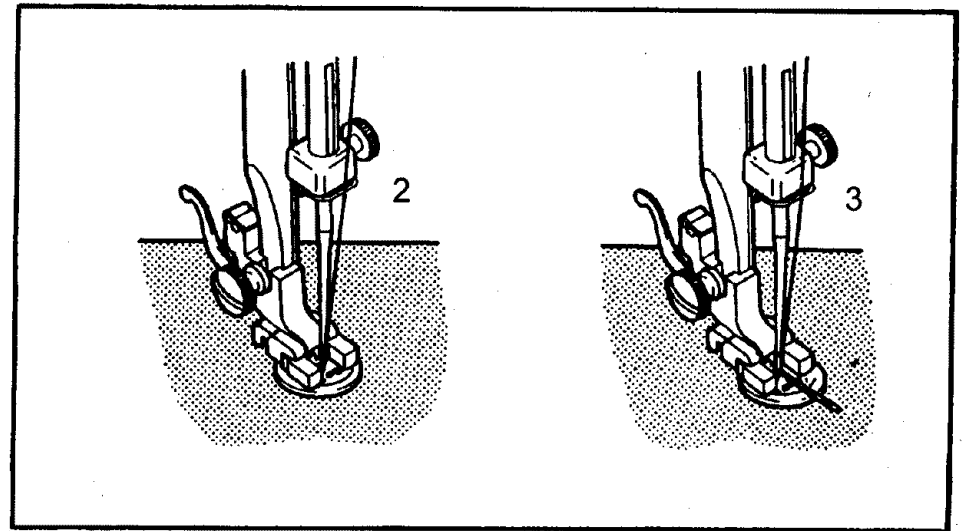

□ How to sew buttonholes (one-step buttonholes)

Buttonhole sewing is a simple process that provides reliable results. However, it is strongly suggested to always make a practice buttonhole on a sample of your fabric and interfacing.

Making a Buttonhole

1. Using tailor's chalk, mark the position of the buttonhole on the fabric.
2. Attach the buttonhole foot and set the pattern selector dial to (I). Set stitch length dial to (□). Adjust stitch width (3 dial machine) to desired width.
3. Lower the presser foot aligning the marks on foot with the marks on the fabric (A). (The front bar tack will be sewn first.) (Align the mark on the fabric (1) with the mark on the foot (2).)
4. Open the button plate and insert the button (B).
5. Lower the buttonhole lever and gently push it back (C).
6. While lightly holding the upper thread, start the machine.
7. Buttonhole stitching is done in the order (D).
8. Stop the machine when the buttonhole is sewn.

Making a Buttonhole on Stretch Fabrics (E)

When sewing buttonholes on stretch fabric, hook heavy thread or cord under the buttonhole foot. When the buttonhole is sewn the legs will overcast the cord.

1. Mark the position of the buttonhole on the fabric with the tailor's chalk, attach the buttonhole foot, and set the pattern selector dial to (I). Set stitch length dial to (□).
2. Hook the heavy thread onto the back end of the buttonhole foot, then bring the two heavy thread ends to the front of the foot, insert them into the grooves and temporarily tie them there.
3. Lower the presser foot and start sewing.
*Set the stitch width to match the diameter of the gimp thread.
4. Once sewing is completed, gently pull the heavy thread to remove any slack, then trim off the excess.

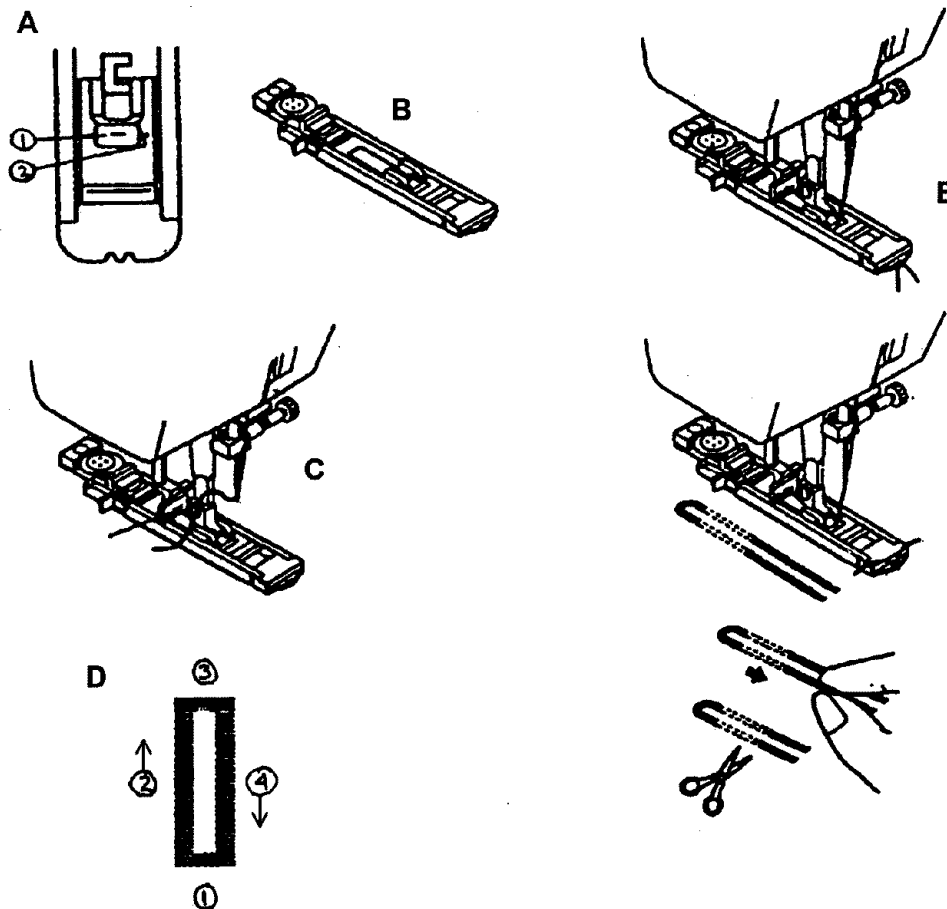

□ Left and right side balance for buttonhole

Stitch density on right and left sides of buttonhole can be adjusted by buttonhole balance control dial.

This dial should usually be in a neutral position (between "+" and "-")

If the stitches on the right side of buttonhole are too close together, turn the dial to the left (+).

* Turning dial to the left opens right side and closes the left side.

If the stitches on the right side of the buttonhole are too open, turn the dial to the right (-).

* Turning dial to right closes right side and opens left side.

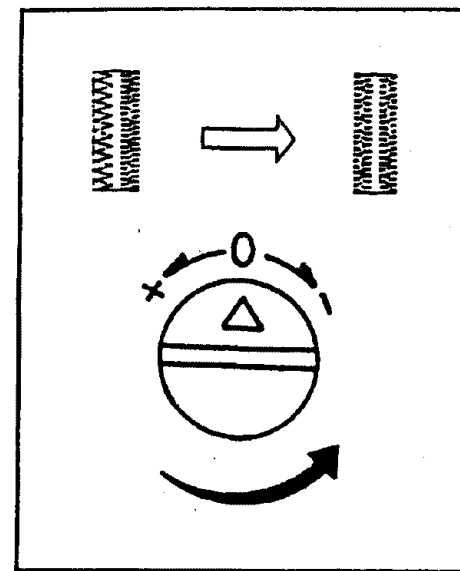
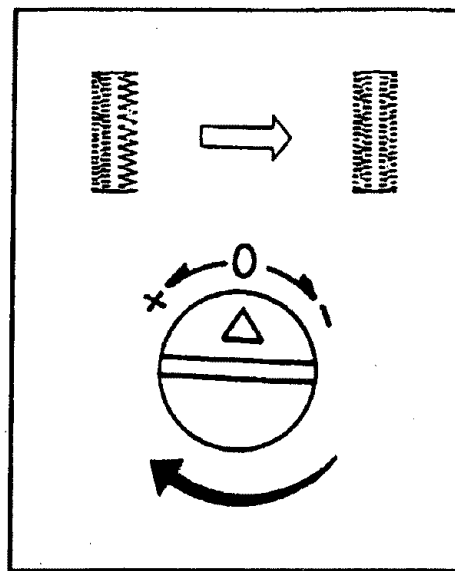
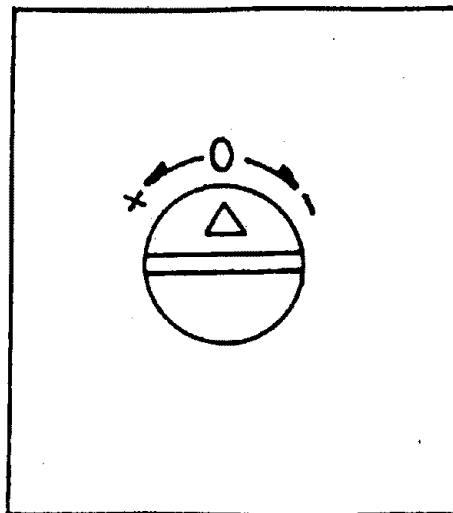

Zippers and piping (For 2 dial model)

Set the pattern selector dial to ().
Change to zipper foot.

The zipper foot can be attached right (1) or left (2) depending on which side of the foot you are going to sew.
To sew past the zipper pull, lower the needle into the fabric, raise the presser foot and push the zipper pull behind the presser foot. Lower the foot and continue to sew.
It is also possible to sew in a length of cord, into a bias strip to form a welt (3).
Set stitch length control between 1-4 (according to thickness of fabric).

Stitch length dial

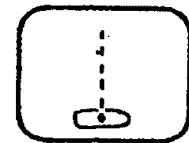
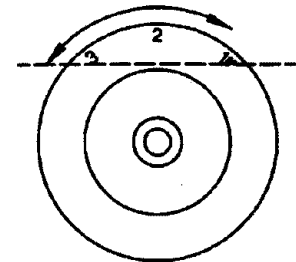

Zipper foot

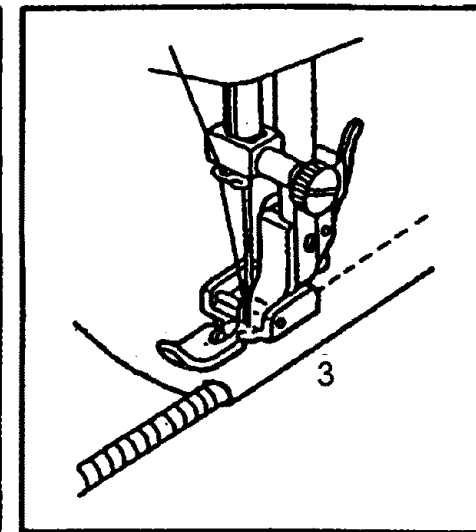
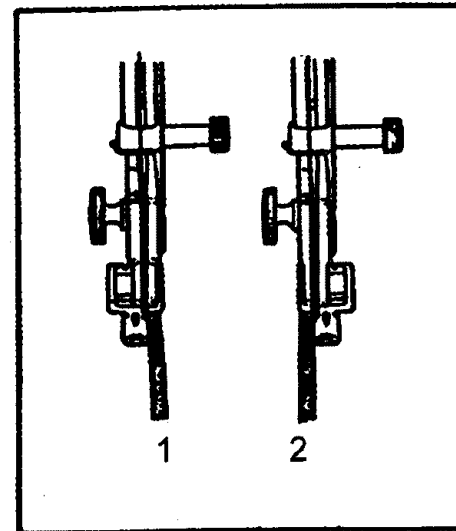

Zippers and piping (For 3 dial models)

Set the pattern selector dial to (:) on 20 stitch pattern model.
Set the pattern selector dial to (A) on 25 stitch pattern model.
Change to zipper foot.

The zipper foot can be attached right (1) or left (2) depending on which side of the foot you are going to sew.
To sew past the zipper pull, lower the needle into the fabric, raise the presser foot and push the zipper pull behind the presser foot. Lower the foot and continue to sew.
It is also possible to sew in a length of cord, into a bias strip to form a 'welt' (3).
Set stitch length control between 1-4 (according to thickness of fabric).

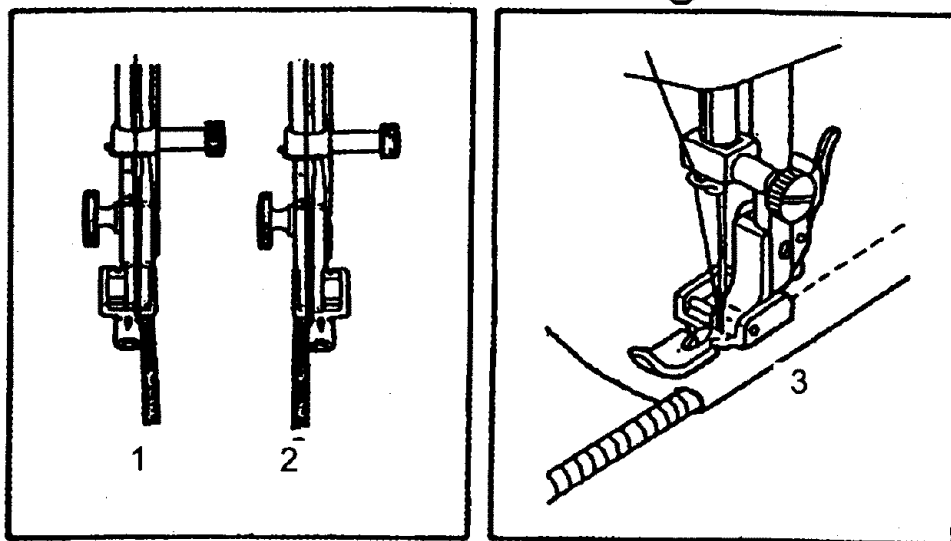
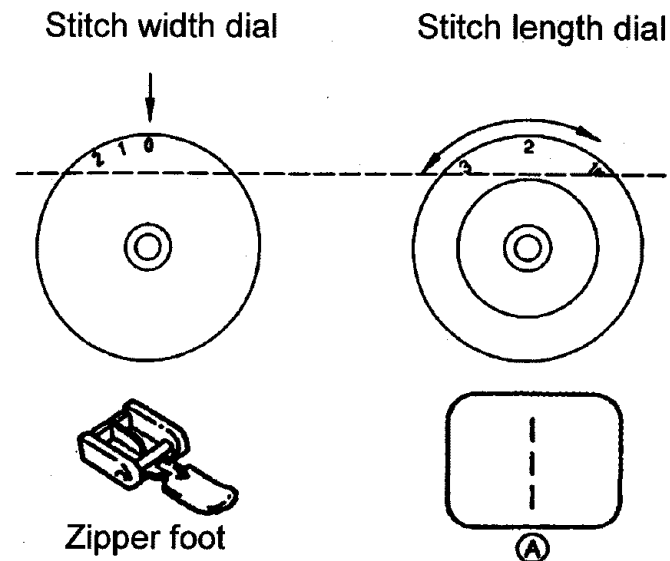

Sewing with the optional hemmer foot (For 2 dial model)

* The hemmer foot is an optional accessory not supplied with your machine.

For hems in fine or sheer fabrics.

Set the stitch pattern dial to () (1).

Change to optional hemmer Foot.

Stitch length dial

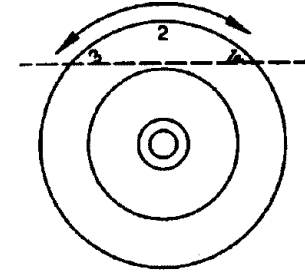

Optional hemmer foot
(Available from your local dealer)

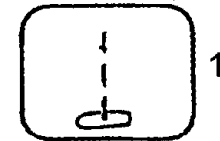

Neaten the edge of the fabric. At the beginning of the hem, turn under the edge twice by about 3 mm (1/8") and sew 4-5 stitches to secure. Pull the thread slightly towards the back. Insert the needle into the fabric, raise the presser foot and guide the fold into the scroll on the foot (2).

Gently pull the fabric edge towards you and lower the presser foot.

Begin sewing, guiding the fabric into the scroll by holding it upright and slightly to the left (3).

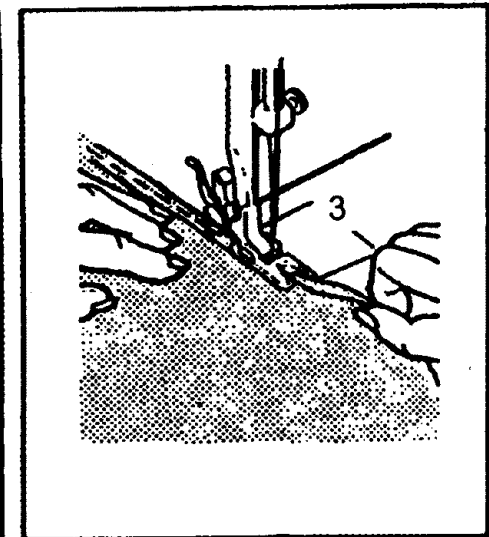
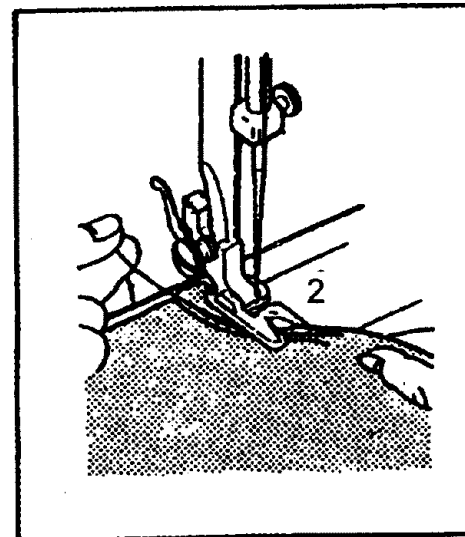

Sewing with the optional hemmer foot (For 3 dial models)

* The hemmer foot is an optional accessory not supplied with your machine.

For hems in fine or sheer fabrics.

Set the stitch pattern dial to (1) on 20 stitch pattern model (1).

Set the stitch pattern dial to (A) on 25 stitch pattern model (1).

Change to optional hemmer foot.

Neaten the edge of the fabric. At the beginning of the hem, turn under the edge twice by about 3 mm (1/8") and sew 4-5 stitches to secure. Pull the thread slightly towards the back. Insert the needle into the fabric, raise the presser foot and guide the fold into the scroll on the foot (2).

Gently pull the fabric edge towards you and lower the presser foot.

Begin sewing, guiding the fabric into the scroll by holding it upright and slightly to the left (3).

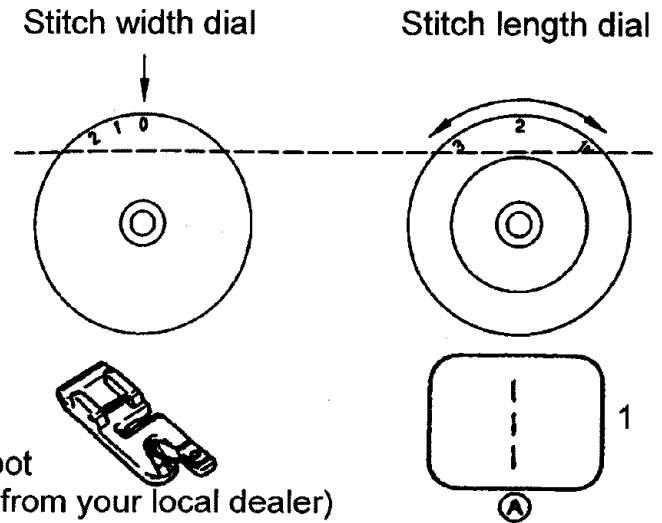

Optional hemmer foot
(Available from your local dealer)

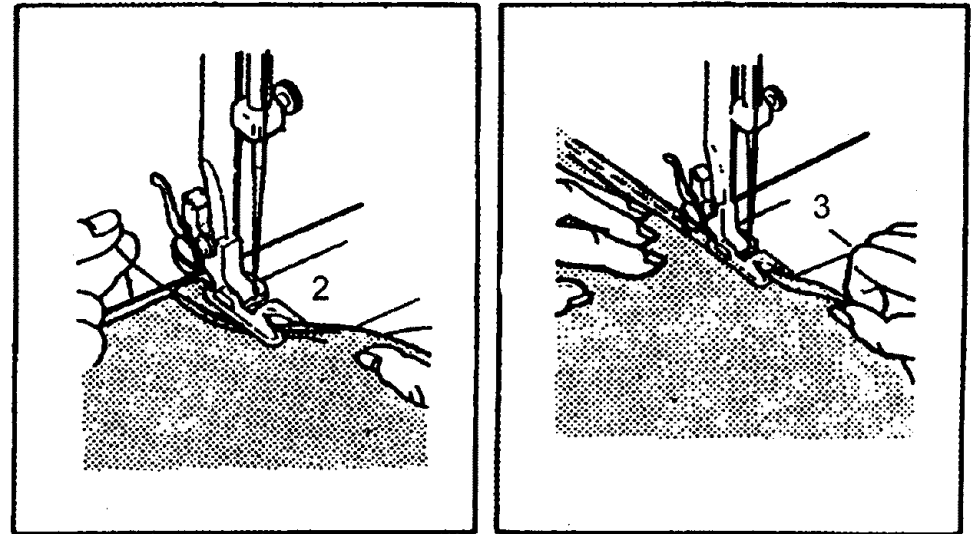

□ Multi-stitch zig-zag (For 2 dial model)

Sewing on lace and elastic, darning, mending, reinforcing edges, bar tacks.

Set the stitch pattern dial to  (1).

Stitch length dial

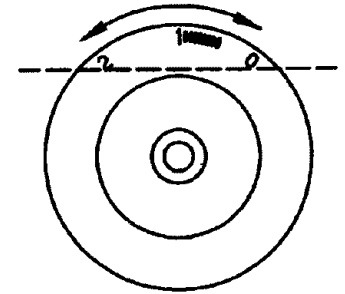

All purpose foot

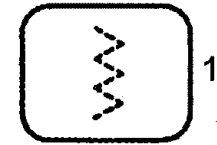

Place patch in position. The stitch length can be shortened to produce very close stitches. (2)

When mending tears, it is advisable to use a piece of backing fabric to reinforce. The stitch density can be varied by adjusting the stitch length. First sew over the centre and then overlap on both sides. Depending on the type of fabric and damage, sew between 3 and 5 rows. (3)

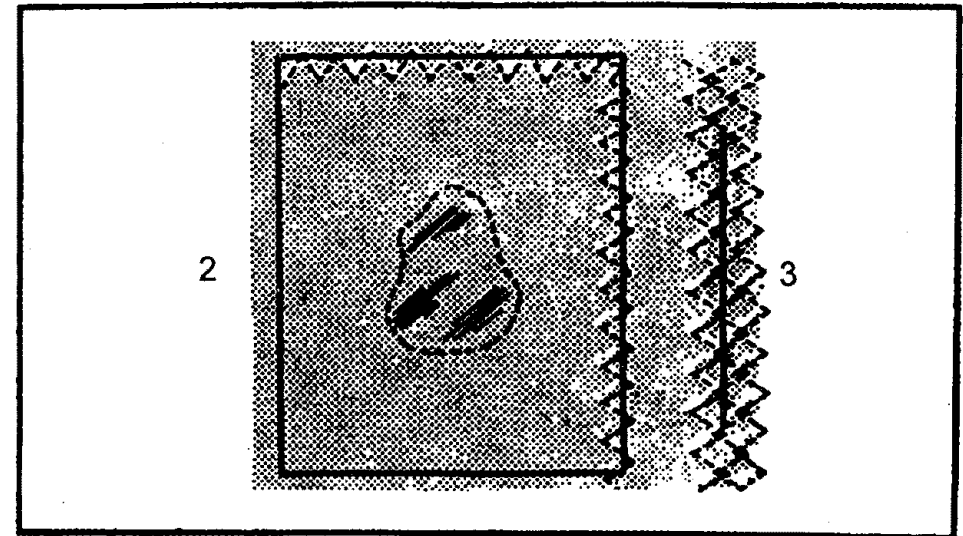

□ Multi-stitch zig-zag (For 3 dial models)

Sewing on lace and elastic, darning, mending, reinforcing edges, bar tacks.

Set the stitch pattern dial to (Z) on 20 stitch pattern model (1).
Set the stitch pattern dial to (C) on 25 stitch pattern model (1).

Place patch in position. The stitch length can be shortened to produce very close stitches. (2)

When mending tears, it is advisable to use a piece of backing fabric to reinforce. The stitch density can be varied by adjusting the stitch length. First sew over the centre and then overlap on both sides. Depending on the type of fabric and damage, sew between 3 and 5 rows. (3)

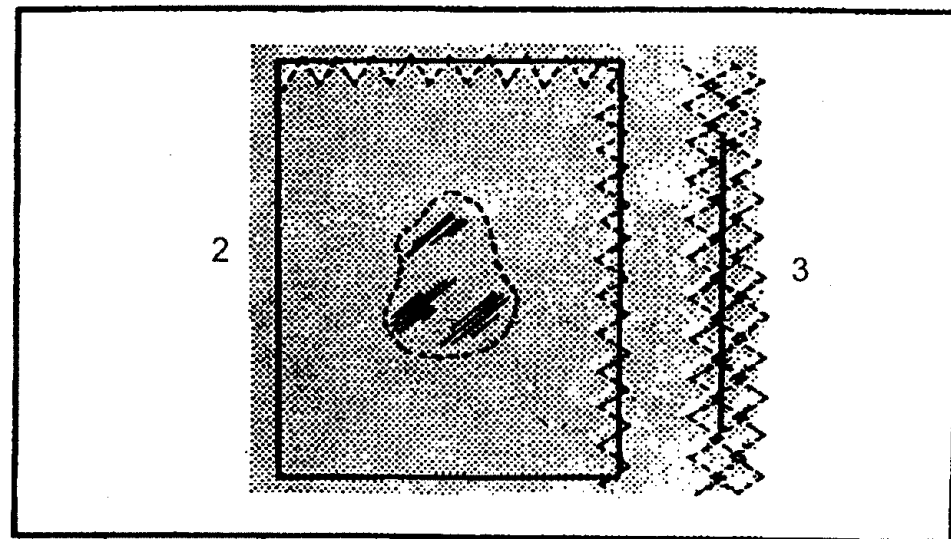
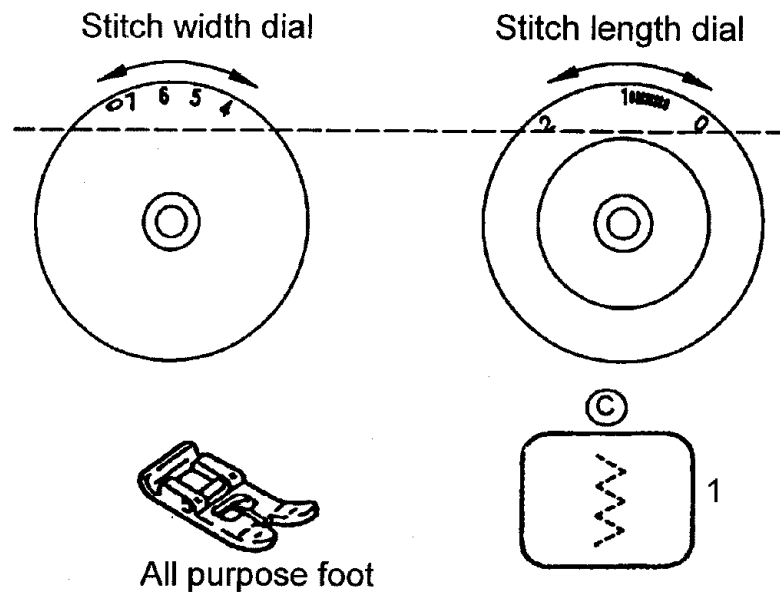

Straight stretch stitch (For 2 dial model)

Set the stitch pattern dial to .

The machine sews two stitches forwards and one stitch backwards.

This gives triple reinforcement to hardwearing seams.

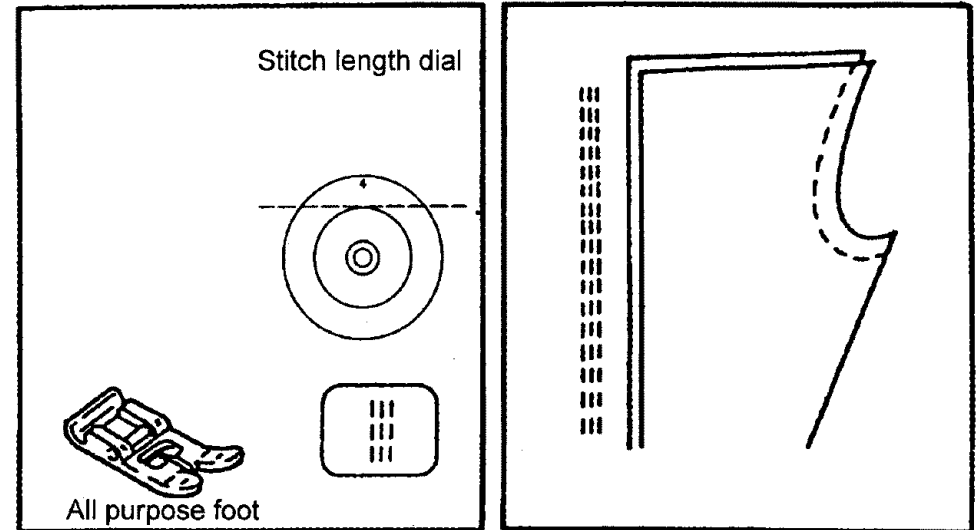

□ Straight stretch stitch and Ric Rac stitch (For 3 dial models)

Straight stretch stitch:

Set the stitch pattern dial to (|||) on 20 stitch pattern model.
 Set the stitch pattern dial to (A) on 25 stitch pattern model.
 Used to add triple reinforcement to stretch and hardwearing seams.

Set the stitch width dial to "0".
 Set the stitch length dial to "S".

Ric Rac stitch:

Set the stitch pattern dial to (S) on 20 stitch pattern model.
 Set the stitch pattern dial to (B) on 25 stitch pattern model.
 Used primarily as a decorative stitch.

Set the stitch length dial to (S).
 Adjust the stitch width dial to between (4 and 7).
 Ric Rac stitch is suitable for firm fabrics like denim, poplin, duck, etc.

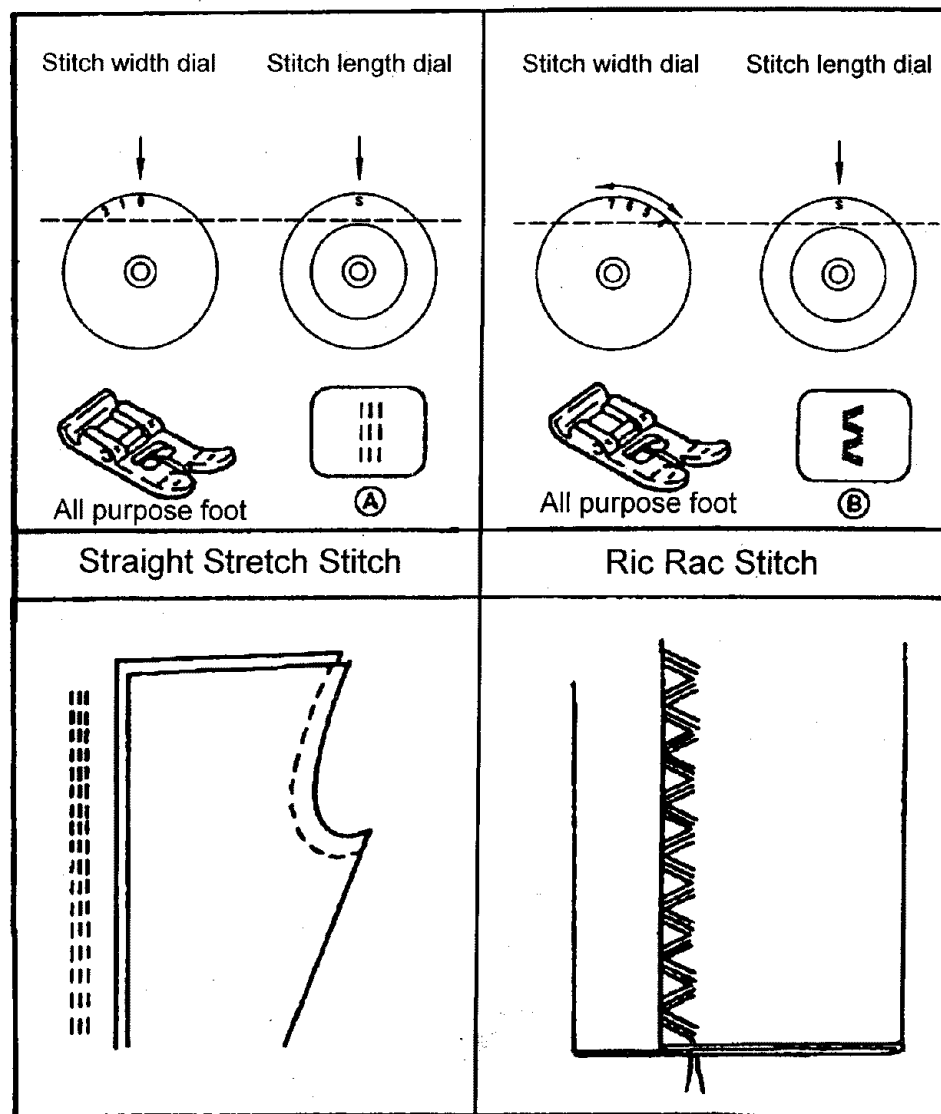

□ Honeycomb stitch (For 3 dial models)

Seams, hems, T-shirts, underwear, etc.
Set the machine as illustrated.

Set stitch pattern selector on (X) on 20 stitch pattern model.
Set stitch pattern selector on (C) on 25 stitch pattern model.

This stitch can be used for all types of jersey and woven fabrics.

When using Honeycomb stitch pattern for hemming sew at 1 cm (1/4") from the fabric edge and trim the surplus fabric.

Set the stitch length dial to "S".

Set the stitch width dial to between "4" and "7".

Stitch width dial

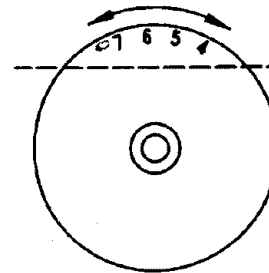

Stitch length dial

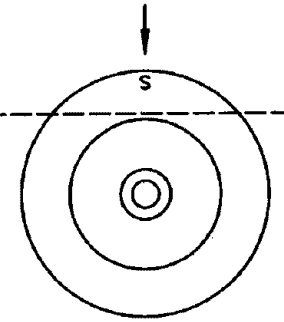

All purpose foot

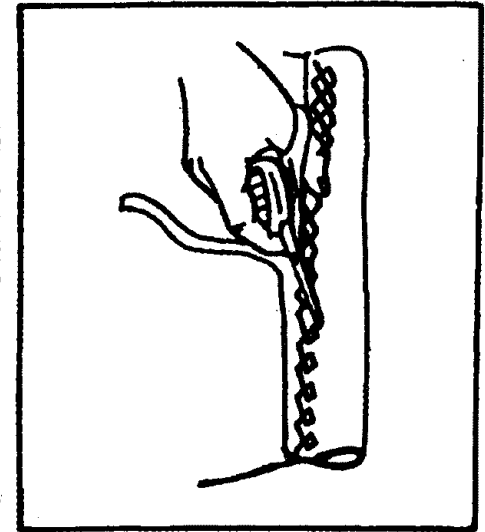
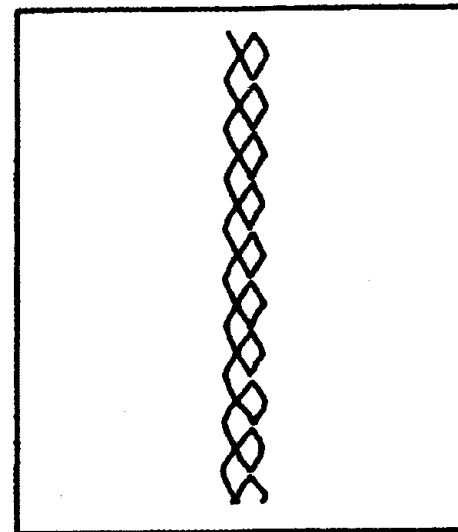
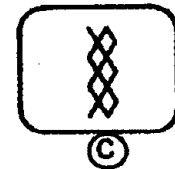

Sewing with the optional cording foot (For 2 dial model)

* The cording foot is an optional accessory not supplied with your machine.

Decorative effects, cushions, tablecloths, etc.

Set stitch selector to position (Σ).

In addition to zig zag, various other stitches are suitable for sewing on cord, e.g. blindhem, multi-stitch zig zag, decorative stitches.

Insert the cord between the spring covering the cord groove and the foot (1). The cord should run in the groove. One, two or three cords can be sewn on. The stitch width is adjusted according to the number of cords and the stitch selected (2).

Optional cording foot

(Available from your local dealer)



Stitch length dial

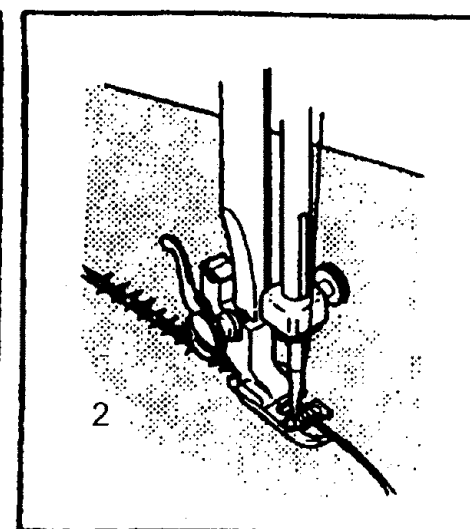
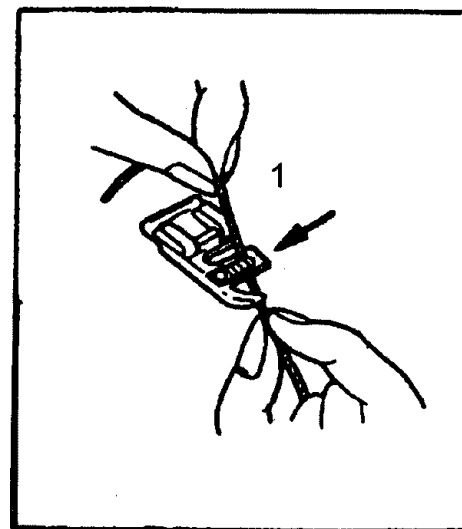
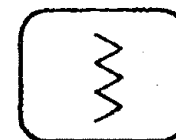
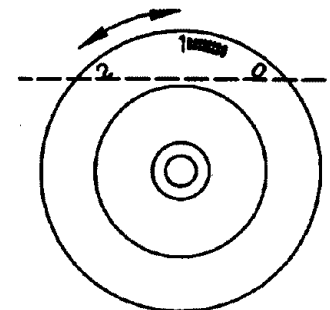

□ Sewing with the optional cording foot (For 3 dial models)

* The cording foot is an optional accessory not supplied with your machine.

Decorative effects, cushions, tablecloths, etc.

Set stitch selector to position Σ . (For 20 stitches)

Set stitch selector to position \textcircled{B} . (For 25 stitches)

In addition to zig zag, various other stitches are suitable for sewing on cord, e.g. blindhem, multi-stitch zig-zag, decorative stitches.

Insert the cord between the spring covering the cord groove and the foot (1). The cord should run in the groove. One, two or three cords can be sewn on. The stitch width is adjusted according to the number of cords and the stitch selected (2).

Stitch width dial

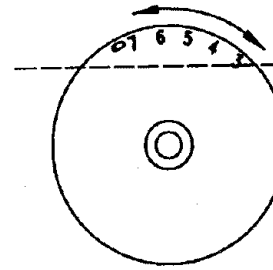

Stitch length dial

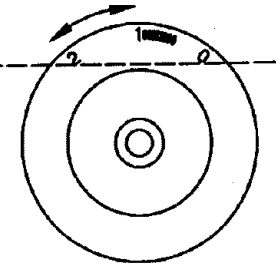

Optional cording foot

(Available from your local dealer)



\textcircled{B}

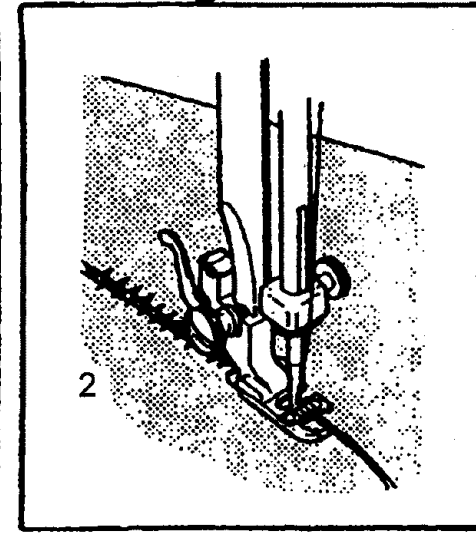
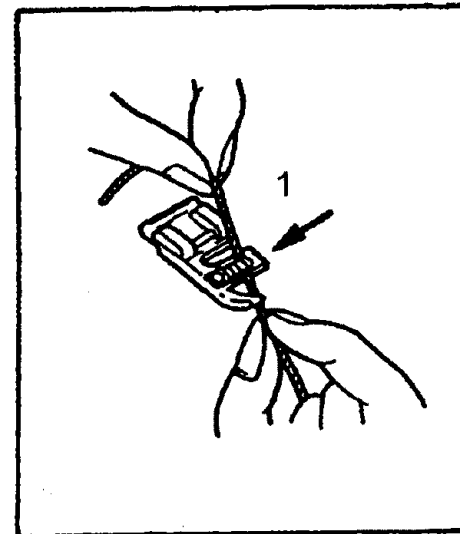

□ Free motion darning (For 2 dial model)

* The darning foot is an optional accessory not included with your machine.

Set stitch pattern selector on (1) (1).

Move the drop feed control to right to lower the feed dogs.
Remove the presser foot clamp (2).

Attach the darning foot to the presser foot holder. The lever (A) should be behind the needle clamp screw (B). Press the darning foot on firmly from behind with your index finger and tighten the screw (C) (3).

First sew around the edge of the hole (to secure the threads) (4). First row: Always work from left to right. Turn work by 1/4 and oversew. An embroidery/darning ring is recommended for easier sewing and better results.

Note: Free motion darning is accomplished without the sewing machine internal feed system. Movement of the fabric is controlled by the operator. It is necessary to coordinate sewing speed and movement of fabric.

Stitch length dial

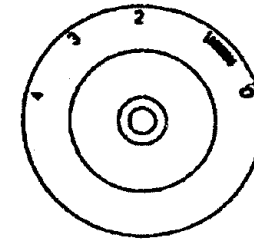

Note: Stitch length cannot be controlled with dial as feed dogs are lowered.

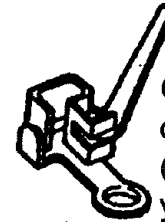

Optional darning foot (Available from your local dealer)

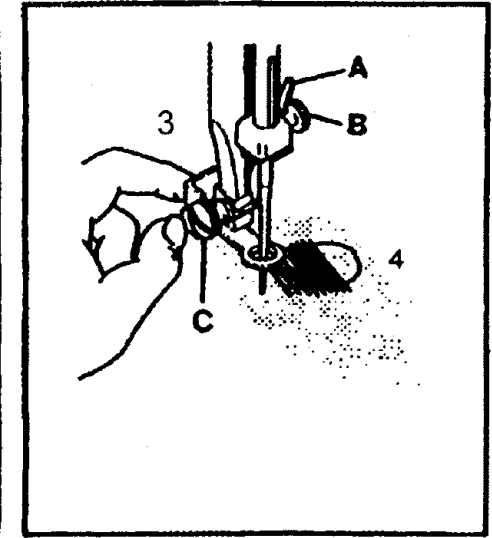
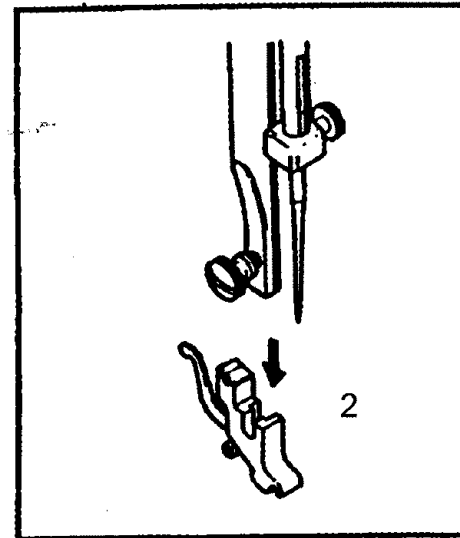
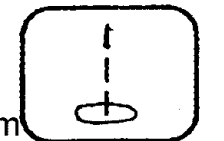

□ Free motion darning (For 3 dial models)

* The darning foot is an optional accessory not included with your machine.

Set the pattern selector dial to (1) on 20 stitch pattern model.

Set the pattern selector dial to (A) on 25 stitch pattern model.

Move the drop feed control to right to lower the feed dogs.

Remove the presser foot clamp (2).

Attach the darning foot to the presser foot holder. The lever (A) should be behind the needle clamp screw (B). Press the darning foot on firmly from behind with your index finger and tighten the screw (C) (3).

First sew around the edge of the hole (to secure the threads) (4). First row: Always work from left to right. Turn work by 1/4 and oversew.

A darning ring is recommended for easier sewing and better results.

Note: Free motion darning is accomplished without the sewing machine internal feed system. Movement of the fabric is controlled by the operator. It is necessary to coordinate sewing speed and movement of fabric.

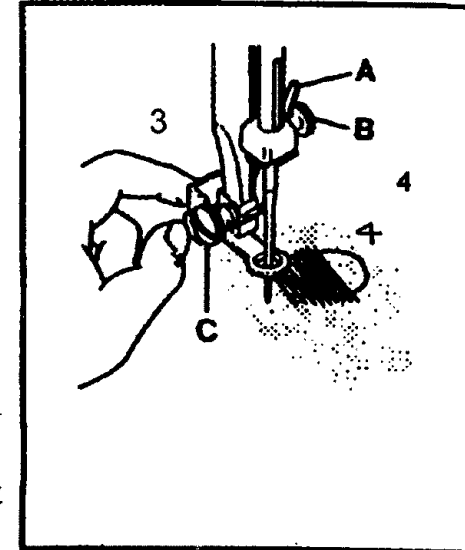
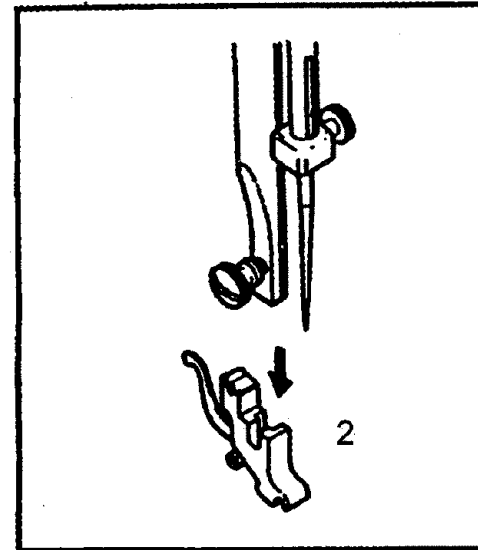
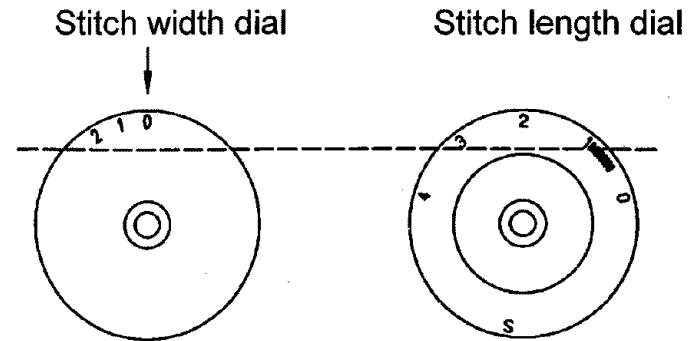

□ Practical stitches (For 2 dial model)

Select desired stitch pattern with pattern selector dial.

Turn the stitch length dial to suit the fabric and application.

Shell stitch (A)

For decorative edges.

Suitable for edges on sheer, fine and stretch fabrics. The larger stitch should go just over the edge of the fabric to create the shell effect.

Feather stitch (B)

For decorative joining seam for a fagotted effect.

Crescent stitch (C)

For a delicate edge finish along the edge of fabric.

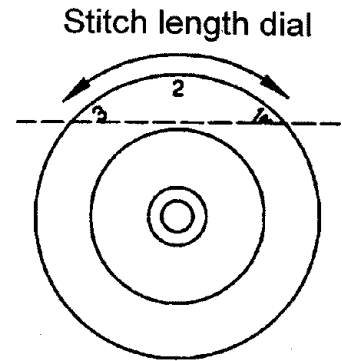

All popose foot

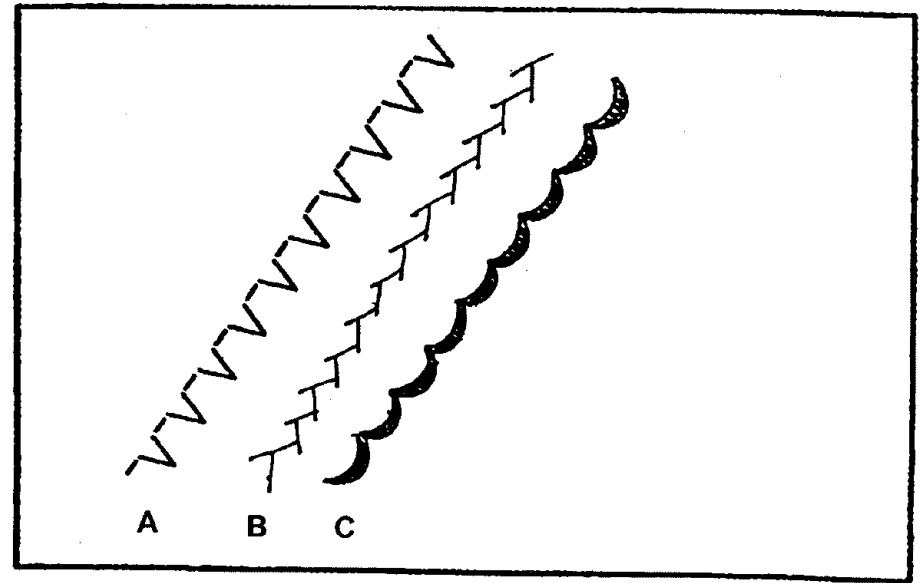
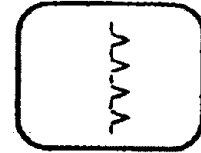

□ Practical stitches (For 3 dial models)

Set the machine as illustrated.

Turn the stitch width dial and stitch length dial to suit the fabric and application.

Shell hem (1) pattern selector on 

For decorative edges.

Suitable for edges on sheer, fine and stretch fabrics. The larger stitch should go just over the edge of the fabric to create the shell effect.

Bridging (2) pattern selector on 

For seams, place mats, tablecloths.

Decorative joining seam for a fagotted effect.

Rampart (3) pattern selector on 

Gathering with cord or shirring elastic.

This stitch can be used for firm, thicker fabrics.

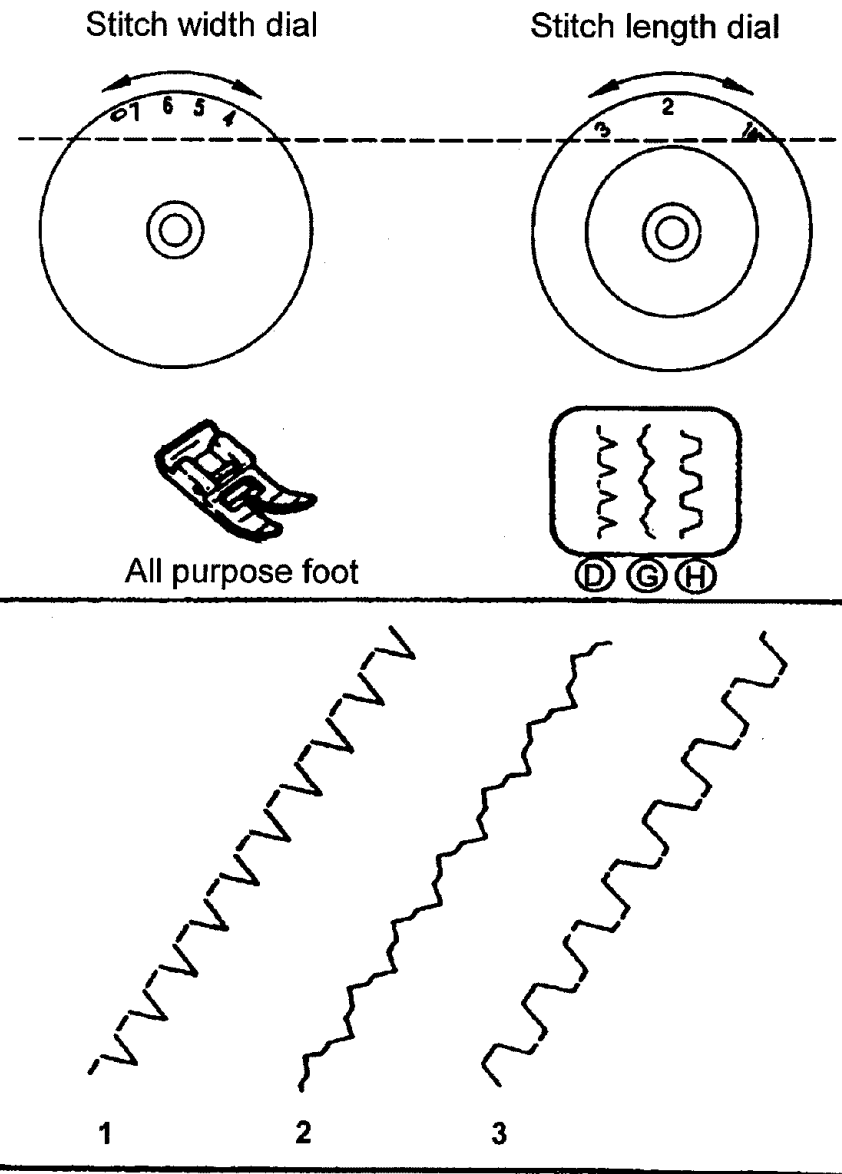

□ Darning

- Turn stitch length dial to the desired length.
- Turn stitch selector to straight stitch, center needle position.
- Position the fabric to be darned under the presser foot together with the under laying fabric to be used.
- Lower the presser foot and alternately sew forward or reverse using the lever.
- Repeat this motion until the area to be darned is filled with rows of stitching.

For reverse sewing instructions, see page 19.

All purpose foot

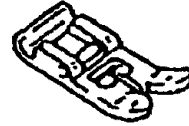

Stitch length dial

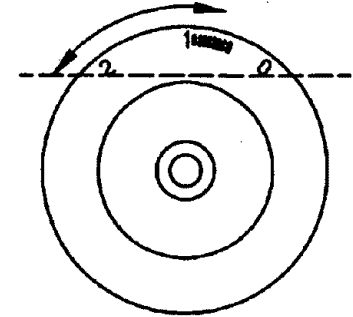

Stitch display

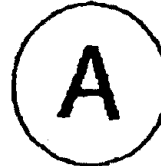

(For 3 dial 25 stitch model)

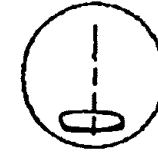

(For 2 dial model)

(For 3 dial 20 stitch model)

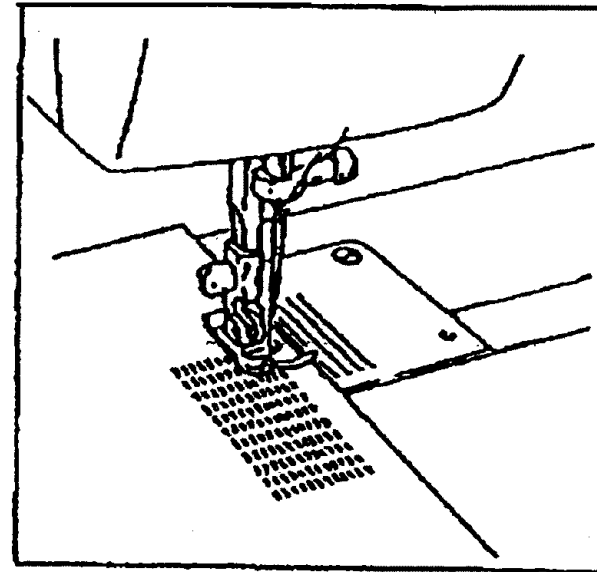

□ Attaching lace

- Turn stitch length dial to the desired length.
- Turn the stitch selector to straight stitch, center needle position.
- Fold in the edge of the fabric (approximately 6 mm 1/4").
- Place the lace under the folded edge of the fabric allowing it to underlap the fabric slightly as required by the pattern of the lace.
- Sew on the edge of the fabric fold.
- You can add a decorative touch by using the satin stitch to sew the lace.

All purpose foot



Stitch length dial

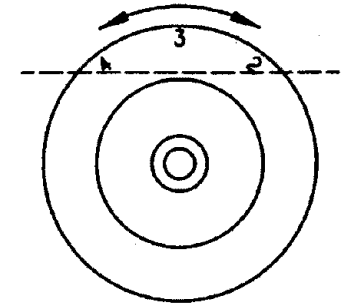

Stitch display

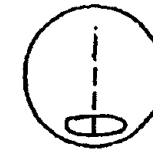
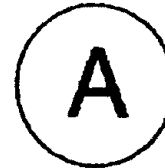

(For 3 dial 25 stitch model)

For 2 dial model)

(For 3 dial 20 stitch model)

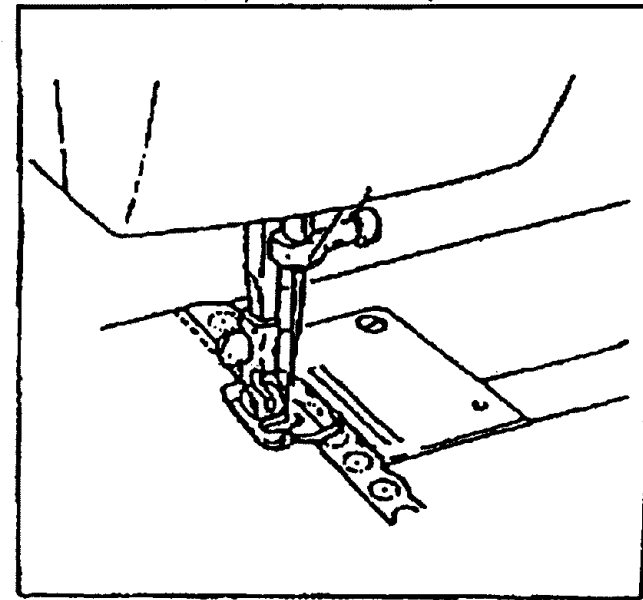

□ Applique

- Turn stitch length dial to the desired length.
- Turn pattern selector dial as illustrated.
- Turn stitch width dial to small width. (For 3 dial models)
- Cut out the applique design and baste it to the fabric.
- Sew slowly around the edge of the design.
- Trim excess material outside the stitching. Make sure not to cut any stitches.
- Remove the basting thread.
- Tie top and bottom thread under the applique to avoid unraveling.

All purpose foot



Stitch display

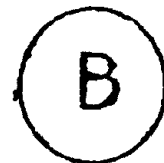

(For 3 dial 25 stitch model)

Stitch length dial

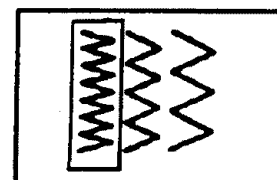
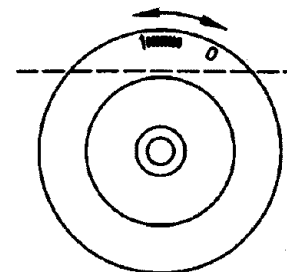

(For 2 dial model)

(For 3 dial 20 stitch model)

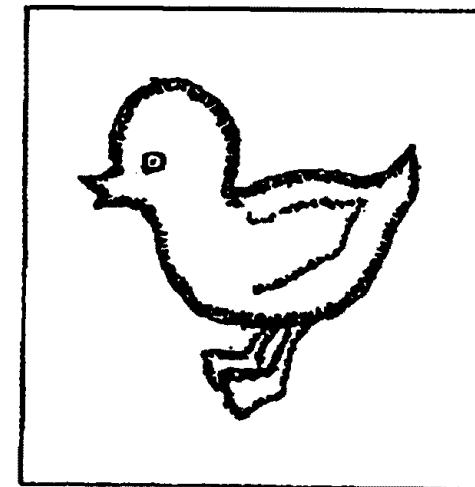
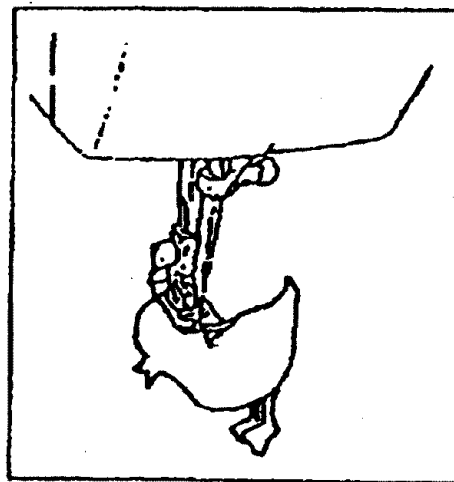

□ Monogramming and embroidering with embroidery hoop*

Drop the feed dogs (Note: Stitch length cannot be controlled with dial)

(see item #24 on page #3)

- Set the machine as illustrated:
- Remove the presser foot and the presser foot holder.
- Lower presser foot lever before starting to sew.
- Adjust the stitch width according to the size of lettering or design.

Preparation for Monogramming and Embroidering*

- Draw the desired lettering or design on the right side of the fabric.
- Stretch the fabric between embroidery hoop as firmly as possible.
- Place the fabric under the needle. Make sure the presser foot bar is down in its lowest position.
- Turn the handwheel towards you to bring up the lower thread through the fabric. Sew a few securing stitches at the starting point.
- Hold the hoop with thumb and forefingers of both hands.
- Coordinate sewing speed and movement of hoop.

Stitch display

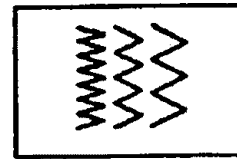

(For 2 dial model)

(For 3 dial 20 stitch model)

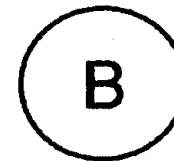

(For 3 dial 25 stitch model)

Stitch width dial

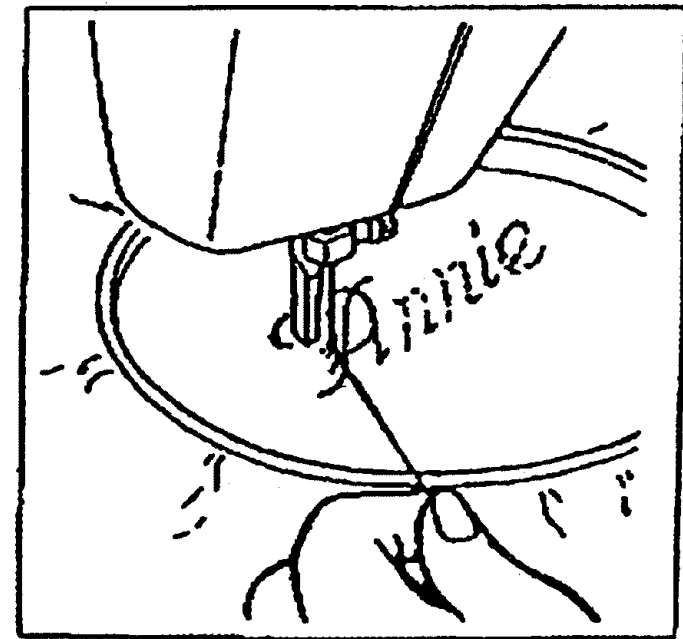
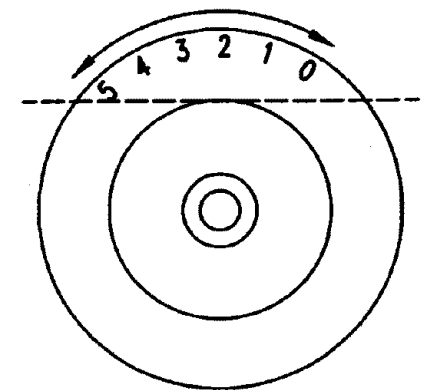

- Embroidery hoop not included with machine.

□ Quilting

* The quilting foot is an optional accessory not supplied with this machine.

Set pattern selector as illustrated.

Insert the quilting guide in presser foot holder and set the space as you desired.

Move the fabric over and sew successive rows with the guide riding along on the previous row of stitching.

Note: Presser foot shown is the optional quilting foot which does not come with your machine. If you have not purchased this foot substitute the all purpose foot.

Stitch length dial

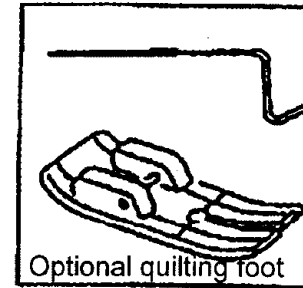
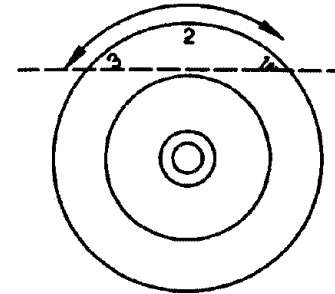

Optional quilting foot

(Available from your local dealer)

Stitch display



(For 3 dial
25 stitch
model)



(For 2 dial
model)
(For 3 dial
20 stitch
model)

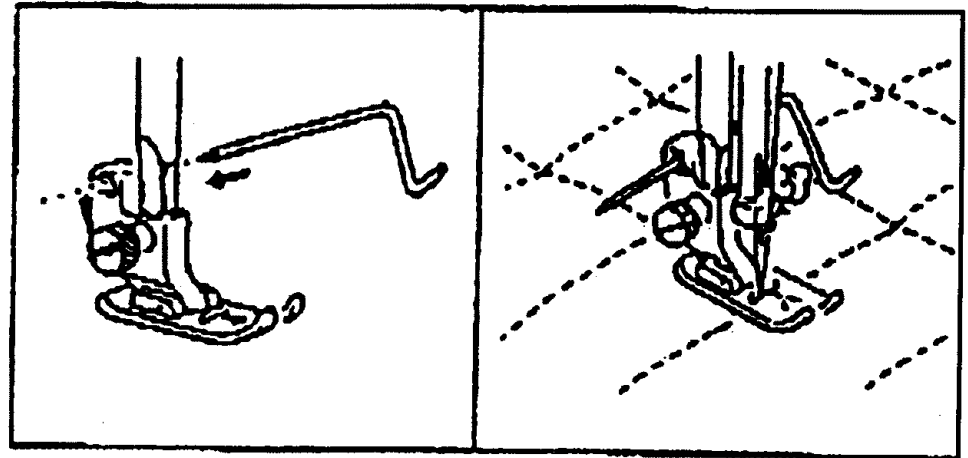

□ Gathering

* The gathering foot is an optional accessory not supplied with this machine.

Set the pattern selector as illustrated.

1. Attach the gathering foot.
2. Sew a single row or multiple rows of straight stitches.
3. If more gathering is required, loosen the upper thread tension to below 2 so that the lower thread lies on the under side of the material.
4. Pull the lower thread to gather more of the material.

Note: Presser foot shown is the optional gathering foot which does not come with your machine. If you have not purchased this foot substitute the all purpose foot and gather fabric by hand by lowering the tension setting to below 2 and pulling the lower thread to gather the material.

Stitch length dial

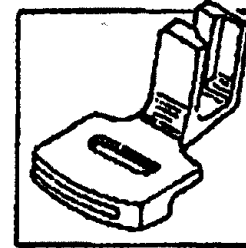
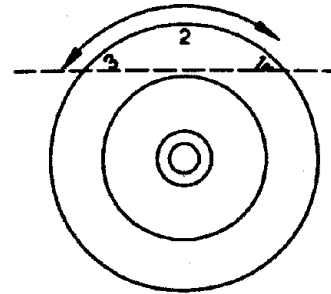

Optional gathering foot
(Available from your local dealer)

Stitch display



(For 3 dial 25
stitch model)



(For 2 dial model)
(For 3 dial 20
stitch model)

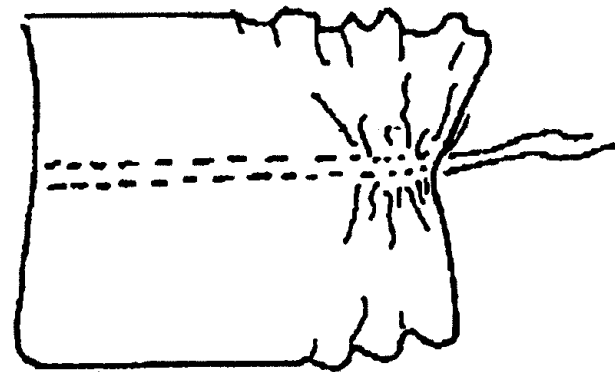

The evenfeed foot optional accessory

* The evenfeed foot is an optional accessory not supplied with this machine.

Always try to sew first without the evenfeed foot accessory which should be used only when necessary.

It is easier to guide the fabric and you have a better view of the seam when using the standard, regular foot on your machine. Your sewing machine offers excellent stitch quality on a wide range of fabrics from delicate chiffons to multiple layers of denim.

The Evenfeed Foot accessory equalizes the feeding of the upper and lower layers of fabric and improves the matching of plaids, stripes and patterns. It also helps to prevent uneven feeding of very difficult fabrics.

- 1) Lift the presser foot lifter to raise the presser foot bar (1).
- 2) Remove the presser foot holder by unscrewing (counterclockwise) the presser bar attaching screw (2).
- 3) Attach the Evenfeed Foot to the machine as follows:
 - i) The arm (3) should fit above the needle screw and clamp (4).
 - ii) Slide the plastic attaching head (5) from your left to right so that it is fitted into the presser foot bar.
 - iii) Lower the presser foot bar (1)
 - iv) Replace and tighten (clockwise) the presser bar attaching screw (2).
- 4) Make sure both the needle screw (4) and the presser bar attaching screw (2) are tightly secured.
- 5) Draw the bobbin thread up and place both the bobbin thread and the needle thread behind the evenfeed foot attachment.

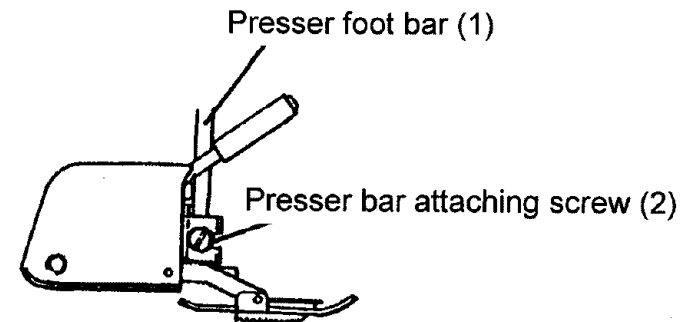
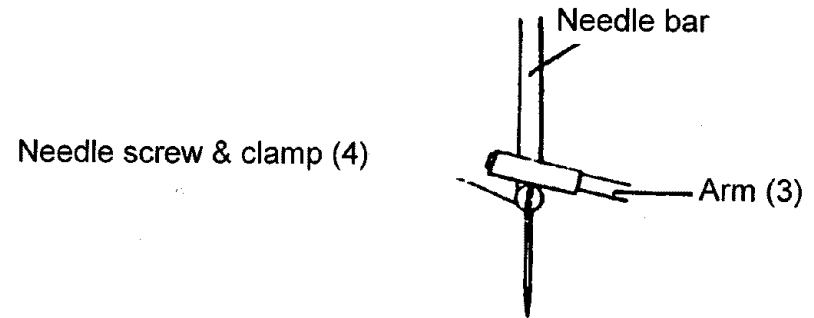
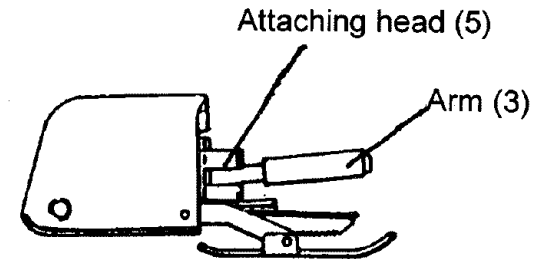

□ Maintenance

Disconnect the machine from the main power source before carrying out any maintenance or changing the sewing light bulb.

Cleaning

If lint and bits of thread accumulate in the hook, this will interfere with the smooth operation of the machine. Check regularly and clean the stitching mechanism when necessary.

A. Bobbin holder

Remove the bobbin cover plate and bobbin.
Clean the bobbin case with a brush.

B. Hook race and feed dog

1. Remove the needle, presser foot and presser foot holder.
Remove the bobbin cover plate and bobbin.
Remove the screw holding the needle plate and remove the needle plate.
2. Lift up bobbin case and remove it.
3. Clean the hook race, feed dog and bobbin case with a brush.
Also clean them, using a soft, dry cloth.
4. Replace the bobbin case into the hook race so that notch (a) rests against the cushion spring (b).

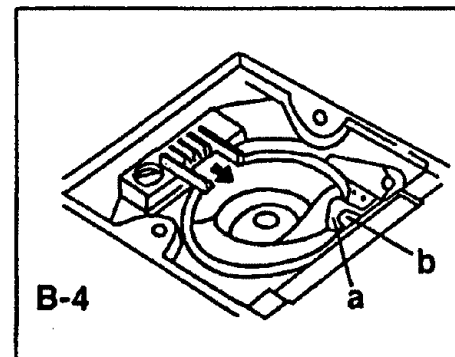
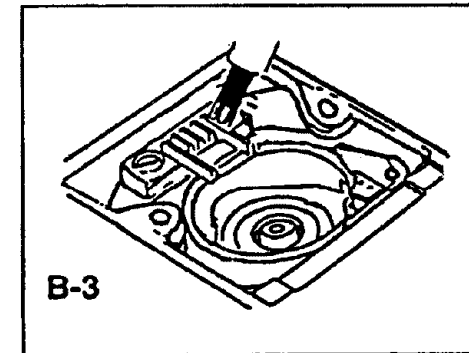
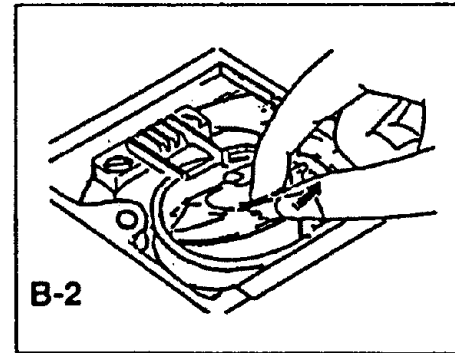
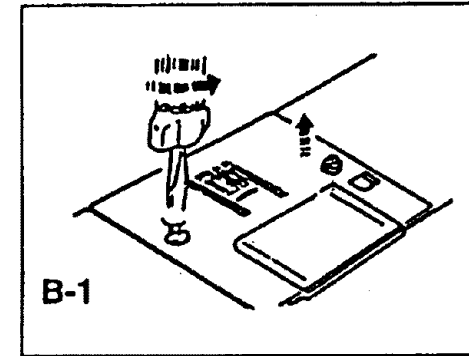
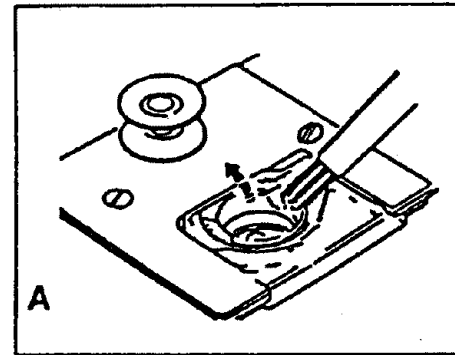

□ Trouble shooting guide

Problem	Cause	Correction
Upper thread breaks	<ol style="list-style-type: none">1. The machine is not threaded correctly2. The thread tension is too tight3. The thread is too thick for the needle4. The needle is not inserted correctly5. The thread is wound around the spool holder pin6. The needle is damaged	<ol style="list-style-type: none">1. Rethread the machine2. Reduce the thread tension (lower number)3. Select a larger needle4. Remove and reinsert the needle (flat side towards the back)5. Remove the spool and wind thread onto thread spool6. Replace the needle
Skipped stitches	<ol style="list-style-type: none">1. The needle is not inserted correctly2. The needle is damaged3. The wrong size needle has been used4. The foot is not attached correctly	<ol style="list-style-type: none">1. Remove and reinsert needle (flat side towards the back)2. Insert a new needle3. Choose a needle to suit the thread and fabric4. Check and attach correctly
Needle breaks	<ol style="list-style-type: none">1. The needle is damaged.2. The needle is not correctly inserted3. Wrong needle size for the fabric4. The wrong foot is attached	<ol style="list-style-type: none">1. Insert a new needle2. Insert the needle correctly (flat side towards the back)3. Choose a needle to suit the thread and fabric4. Select the correct foot
Loose stitches	<ol style="list-style-type: none">1. The machine is not correctly threaded2. The bobbin case is not correctly threaded3. Needle/fabric/thread combination is wrong4. Thread tension wrong	<ol style="list-style-type: none">1. Check the threading2. Thread the bobbin case as illustrated3. The needle size must suit the fabric and thread4. Correct the thread tension
Seams gather or pucker	<ol style="list-style-type: none">1. The needle is too thick for the fabric2. The stitch length is wrongly adjusted3. The thread tension is too tight	<ol style="list-style-type: none">1. Select a finer needle2. Readjust the stitch length3. Loosen the thread tension
Uneven stitches. uneven feed	<ol style="list-style-type: none">1. Poor quality thread2. The bobbin case is wrongly threaded3. Fabric has been pulled	<ol style="list-style-type: none">1. Select a better quality thread2. Remove bobbin and rethread and insert correctly3. Do not pull on the fabric while sewing, let it be fed by the machine
The machine is noisy	<ol style="list-style-type: none">1. The machine must be lubricated2. Fluff or oil have collected on the hook or needle bar3. Poor quality oil has been used4. The needle is damaged	<ol style="list-style-type: none">1. Take machine to dealer for proper servicing2. Clean the hook and feed dog as described3. Take machine to dealer for proper cleaning and servicing4. Replace the needle
The machine jams	<ol style="list-style-type: none">1. Thread is caught in the hook	<ol style="list-style-type: none">1. Remove the upper thread and bobbin, gently turn the handwheel backwards and forwards by hand and remove the thread remnants.

