

Save This Manual
For Future Reference

SEARS

owners
manual

MODEL NO.
113.244500
10-INCH BAND SAW

Serial
Number _____
Model and serial numbers
may be found on the back
of the saw.
You should record both
model and serial number in
a safe place for future use.

**FOR YOUR
SAFETY:**

**READ ALL
INSTRUCTIONS
CAREFULLY**

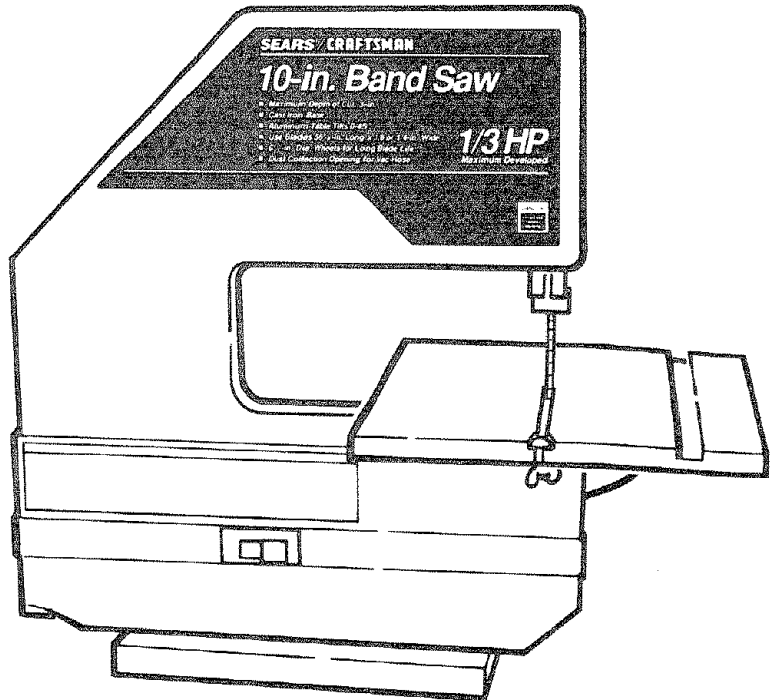

SEARS / CRAFTSMAN

10-INCH BAND SAW

- assembly
- operating
- repair parts

Sold by SEARS, ROEBUCK AND CO., Chicago, IL 60684 U.S.A.

Part No. SP5492

Printed in Taiwan

FULL ONE YEAR WARRANTY ON CRAFTSMAN BAND SAW

If within one year from the date of purchase, this Craftsman Band Saw fails due to a defect in material or workmanship, Sears will repair it, free of charge.

WARRANTY SERVICE IS AVAILABLE BY SIMPLY CONTACTING THE NEAREST SEARS SERVICE CENTER/DEPARTMENT THROUGHOUT THE UNITED STATES.

This warranty applies only while this product is used in the United States.

This warranty gives you specific legal rights, and you may also have other rights which vary from state to state.

SEARS, ROEBUCK AND CO., Dept. 698/731A, Sears Tower, Chicago, IL 60684

Safety Instructions for Band Saw

Safety is a combination of common sense, staying alert and knowing how your band saw works. Read this manual to understand this saw.

BEFORE USING THE SAW:

WARNING: To avoid mistakes that could cause serious, permanent injury, do not plug the saw in until the following steps are completed.

- Assembly and alignment. (See pages 7-12).

- Learn the use and function of the ON-OFF switch, table lock knob, blade guides, backup bearings, upper slide lock knob, blade guard, tension catch, and tracking screw. (See pages 13 & 14)
- Review and understand all of the safety instruction and operating procedures in this manual.
- Review the maintenance methods for this saw. (See page 18)

Read the following WARNING labels found on the front of the saw:

▲ WARNING

- | | | |
|---|--|---|
| 1. Read manual before using saw. | 4. Keep fingers away from the moving blade. | 7. Adjust upper guide to just clear the wood. |
| 2. Wear safety goggles that meet ANSI Z87.1 standards. | 5. Do not remove jammed cutoff pieces until blade has stopped. | 8. Hold workpiece firmly against the table. |
| 3. Be sure blade is installed with teeth pointing down. | 6. Maintain proper adjustment of blade tension, blade guides, and thrust bearings. | 9. Turn power off and wait for blade to stop before adjusting or servicing. |

MOTOR: 1725 RPM 1PHASE 120 VOLT AC ONLY 60 HZ 2.3 AMPS

PULL ON — PUSH OFF



DANGER

Let tool stop
before
adjusting
Blade Guide.

WHEN INSTALLING OR MOVING THE SAW.

AVOID DANGEROUS ENVIRONMENT. Use the saw in a dry, indoor place protected from rain. Keep work area well lighted.

To avoid injury from unexpected saw movement:

- Put the saw on a firm level surface where there is plenty of room for handling and properly supporting the workpiece.
- Support the saw so the table is level and the saw does not rock.
- Bolt the saw to the support surface if it tends to slip, walk, or slide during operations like cutting long, heavy boards.
- Turn saw off and unplug cord before moving the saw.

To avoid injury or death from electrical shock:

- **GROUND THE SAW.** This saw has an approved 3-conductor cord and a 3-prong grounding type plug. Use only 3-wire, grounded outlets rated 120 volts, 15 amperes (amps). The green conductor in the cord is the grounding wire. To avoid electrocution, NEVER connect the green wire to a live terminal.

- Make sure your fingers do not touch the plug's metal prongs when plugging or unplugging the saw.

NEVER STAND ON TOOL. Serious injury could occur if the tool tips or you accidentally hit the cutting tool. Do not store anything above or near the tool where anyone might stand on the tool to reach them.

BEFORE EACH USE:

Inspect your saw.

DISCONNECT THE SAW. To avoid injury from accidental starting, unplug the saw, turn the switch off and remove the switch key before changing the setup, opening covers, removing guards, or blade.

CHECK FOR DAMAGED PARTS. Check for:

- alignment of moving parts,
- binding of moving parts,
- broken parts,
- stable mounting, and
- any other conditions that may affect the way the saw works.

If any part is missing, bent, or broken in any way, or any electrical part doesn't work properly, turn the saw off and unplug the saw. REPLACE damaged, missing, or failed parts before using the saw again.

MAINTAIN TOOLS WITH CARE. Keep the saw clean for best and safest performance. Follow instructions for lubricating.

REMOVE ADJUSTING KEYS AND WRENCHES from tool before turning it on.

To avoid injury from jams, slips or thrown pieces:

- Choose the right size and style blade for the material and the type of cutting you plan to do.
- **USE ONLY RECOMMENDED ACCESSORIES.** (See page 18). Consult this owner's manual for recommended accessories. Follow the instructions that come with the accessories. The use of improper accessories may cause risk of injury to persons.
- Make sure the blade teeth point downward, toward the table.
- Make sure the blade guides and thrust bearings are properly adjusted.
- Make sure the blade tension is properly adjusted.
- Make sure the table lock knob is tight and no parts have excessive play.
- To avoid accidental blade contact, minimize blade breakage and provide maximum blade support, always adjust the upper blade guide and blade guard to just clear the workpiece.
- **KEEP WORK AREA CLEAN.** Cluttered areas and benches invite accidents. Floor must not be slippery.

To avoid burns or other fire damage, never use the saw near flammable liquids, vapors or gases.

Plan ahead to protect your eyes, hands, face, ears.

KNOW YOUR SAW. Read and understand the owner's manual and labels affixed to the tool. Learn its application and limitations as well as the specific potential hazards peculiar to this tool.

To avoid injury from accidental contact with moving parts, don't do layout, assembly, or setup work on the saw while any parts are moving.

AVOID ACCIDENTAL STARTING. Make sure switch is "OFF" before plugging saw into a power outlet.

Plan your work.

- **USE THE RIGHT TOOL.** Don't force tool or attachment to do a job it was not designed to do.
- Use this band saw to cut only wood, wood like products, and plastics.

Dress for safety.



Any power saw can throw foreign objects into the eyes. This can cause permanent eye damage. Wear safety goggles (not glasses) that comply with ANSI Z87.1 (shown on package). Everyday eyeglasses have only impact resistant lenses. They are not safety glasses. Safety goggles are available at Sears retail catalog stores. Glasses or goggles not in compliance with ANSI Z87.1 could seriously hurt you when they break.

- Do not wear loose clothing, gloves, neckties or jewelry (rings, wrist watches). They can get caught and draw you into moving parts.
- Wear nonslip footwear.
- Tie back long hair.
- Roll long sleeves above the elbow.
- Noise levels vary widely. To avoid possible hearing damage, wear ear plugs or muffs when using your saw for hours at a time.
- For dusty operations, wear a dust mask along with the safety goggles.

Inspect your workpiece.

Make sure there are no nails or foreign objects in the part of the workpiece to be cut.

Use extra caution with large, very small or awkward workpieces:

- Use extra supports (tables, saw horses, blocks, etc.) for any workpieces large enough to tip when not held down to the table top.
- **NEVER** use another person as a substitute for a table extension, or as additional support for a workpiece that is longer or wider than the basic saw table, or to help feed, support or pull the workpiece.
- When cutting irregularly shaped workpieces, plan your work so it will not pinch the blade. A piece of molding, for example, must lay flat or be held by a fixture or jig that will not let it twist, rock or slip while being cut.
- Properly support round material such as dowel rods, or tubing. They have a tendency to roll during a cut, causing the blade to "bite". To avoid this, always use a "V" block or clamp the work to the miter gage.
- Cut only one workpiece at a time.
- Clear everything except the workpiece and related support devices off the table before turning the saw on.

Plan the way you will hold the workpiece from start to finish.

Do not hand hold pieces so small that your fingers will go under the blade guard. Use jigs or fixtures to hold the work and keep your hands away from the blade.

Avoid awkward operations and hand positions where a sudden slip could cause fingers or hand to move into the blade.

DONT OVERREACH. Keep good footing and balance.

WHENEVER SAW IS RUNNING.

WARNING: Don't let familiarity (gained from frequent use of your band saw) cause a careless mistake. A careless fraction of a second is enough to cause a severe injury.

Before starting your cut, watch the saw while it runs. If it makes an unfamiliar noise or vibrates a lot, stop immediately. Turn the saw off. Unplug the saw. Do not restart until finding and correcting the problem.

KEEP CHILDREN AWAY. Keep all visitors a safe distance from the saw. Make sure bystanders are clear of the saw and workpiece.

DONT FORCE TOOL. It will do the job better and safer at its designed rate. Feed the workpiece into the saw blade only fast enough to let it cut without bogging down or binding.

Before freeing any jammed material:

- Turn switch "OFF".
- Remove switch key.
- Unplug the saw.
- Wait for all moving parts to stop.

When backing up the workpiece, the blade may bind in the kerf (cut). This is usually caused by sawdust clogging up the kerf or because the blade comes out of the guides. If this happens:

- Turn switch "OFF".
- Remove switch key.
- Unplug saw.
- Wait for all moving parts to stop.
- Open band saw cover.
- Stick flat blade screwdriver or wedge into the kerf.
- Turn the upper wheel by hand while backing up the workpiece.

Before removing loose pieces from the table, turn saw off and wait for all moving parts to stop.

BEFORE LEAVING THE SAW:

Wait for all moving parts to stop.

Make workshop child-proof. Lock the shop. Disconnect master switches. Remove the yellow switch key. Store it away from children and others not qualified to use the tool.

glossary of terms for woodworking

Beveling

An angle cutting operation through the face of the board.

Crosscut

A cutting operation made across the width of the workpiece.

Compound Cutting

A simultaneous bevel and miter cutting operation.

FPM

Feet per minute. Used in reference to surface speed of blade.

Freehand (as used for band saw)

Performing a cut without the workpiece properly supported on the work table.

Gum

A sticky, sap-based residue from wood products.

Kerf

The material removed by the blade in a through cut or the slot produced by the blade in a non-through or partial cut.

Leading End

The end of the workpiece which is pushed into the cutting tool first.

Mitering

An angle cutting operation made across the width of the workpiece.

Push Stick

A device used to feed the workpiece through the saw

during narrow ripping type operations so the operator's hands are kept well away from the blade.

Resaw

A cutting operation to reduce the thickness of the workpiece to make thinner pieces.

Resin

A sticky, sap-based substance that has dried.

Ripping

A cutting operation along the length of the workpiece.

Sawblade Path

The area of the worktable or workpiece directly in line with the saw blade.

Set

The distance the tip of the saw blade tooth is bent outward from the face of the blade.

Tracking

Adjusting the upper wheel so the bandsaw blade runs in the center of the wheels.

Trailing End

The workpiece end last cut by the saw blade.

Workpiece

The item on which the cutting operation is being performed. The surfaces of a workpiece are commonly referred to as faces, ends, and edges.

Worktable

The surface on which the workpiece rests while performing a cutting operation.

motor specifications and electrical requirements

This machine is designed to use, and is equipped with, a **1725 RPM** motor. It is wired for operation on 120 volts, 60 Hz., alternating current. (TOOL MUST NOT BE CONVERTED TO OPERATE ON 230 VOLT).

For replacement motor refer to parts list in this manual.

CONNECTING TO POWER SUPPLY OUTLET

This machine must be grounded while in use to protect the operator from electric shock.

Plug power cord into a 120V properly grounded type outlet protected by a 15-amp. fuse or circuit breaker.

If you are not sure that your outlet is properly grounded, have it checked by a qualified electrician.

WARNING: Do not permit fingers to touch the terminals of plugs when installing or removing the plug to or from the outlet.

WARNING: If not properly grounded this power tool can cause an electrical shock, particularly when used in damp locations close to plumbing. If an electrical shock occurs there is the potential of a secondary hazard such as your hands contacting the saw blade.

If power cord is worn or cut, or damaged in any way, have it replaced immediately.

Your unit is for use on 120 volts, and has a plug that looks like the one shown below.

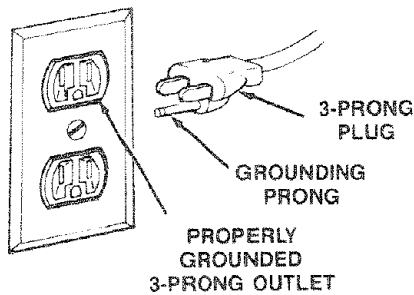

This power tool is equipped with a 3-conductor cord and grounding type plug approved by Underwriters' Laboratories. The ground conductor has a green jacket and is attached to the tool housing at one end and to the ground prong in the attachment plug at the other end.

This plug requires a mating 3-conductor grounded type outlet as shown.

If the outlet you are planning to use for this power tool is of the two prong type, **DO NOT REMOVE OR ALTER THE GROUNDING PRONG IN ANY MANNER.** Use an adapter as shown below and always connect the grounding lug to a known ground.

It is recommended that you have a qualified electrician replace the TWO prong outlet with a properly grounded THREE prong outlet.

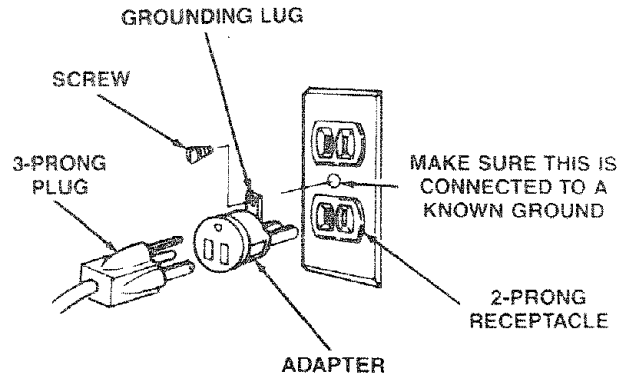

An adapter as illustrated is available for connecting plugs to 2-prong receptacles. The green grounding lug extending from the adapter must be connected to a permanent ground such as to a properly grounded outlet box.

NOTE: The adapter illustrated is for use only if you already have a properly grounded 2-prong receptacle.

The use of any extension cord will cause some loss of power. To keep this to a minimum and to prevent overheating and motor burn-out, use the table below to determine the minimum wire size (A.W.G.) extension cord.

Use only a single cord when an extension cord is required. The cord must be a 3 wire extension cord which has a 3-prong receptacle that will accept the tools plug.

Length of the Cord	Wire Sizes Required (American Wire Gage Number) 120V Lines
25 Feet	No. 16
50 Feet	No. 16
100 Feet	No. 16

contents

POWER TOOL WARRANTY	2	Adjusting the Blade Guides and Back-Up Bearing	11
SAFETY INSTRUCTIONS FOR BAND SAW	2	Final Table Assembly	12
GLOSSARY OF TERMS FOR WOODWORKING	4	Aligning the Table Square to the Blade	12
MOTOR SPECIFICATIONS AND ELECTRICAL REQUIREMENTS	5	Installing the Hose Clip	13
UNPACKING AND CHECKING CONTENTS	6	Getting to Know your Band Saw	14
ASSEMBLY		BASIC BAND SAW OPERATION	16
Mounting Band Saw to Workbench	7	MAINTENANCE	19
Installing the Table	8	RECOMMENDED ACCESSORIES	19
Installing the Blade	9	TROUBLESHOOTING	20
Tensioning the Blade	10	REPAIR PARTS	21
Tracking the Blade	11		

unpacking and checking contents

TOOLS NEEDED

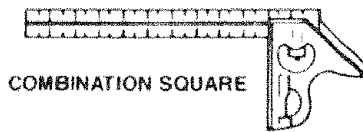

COMBINATION SQUARE

#2 PHILLIPS SCREWDRIVER



MEDIUM SCREWDRIVER



1/2 INCH WRENCH

COMBINATION SQUARE MUST BE TRUE

DRAW-LIGHT LINE ON BOARD ALONG THIS EDGE

STRAIGHT EDGE OF BOARD 3/4" THICK THIS EDGE MUST BE PERFECTLY STRAIGHT

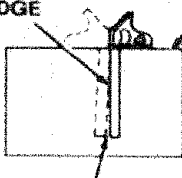

SHOULD BE NO GAP OR OVERLAP HERE WHEN SQUARE IS FLIPPED OVER IN DOTTED POSITION

WARNING: To avoid injury from unexpected starting or electrical shock, do not plug the saw in until all assembly and alignment steps are complete. The power cord must remain unplugged whenever you are working on the saw.

Model 113.244500 Band Saw is shipped complete in one carton.

Separate all parts from packing materials and check each item with illustration and "Table of Loose Parts". Make certain all items are accounted for, before discarding any packing material.

WARNING: If any parts are missing, do not try to assemble the band saw, plug in the power cord, or turn the switch on until the missing parts are obtained and installed correctly.

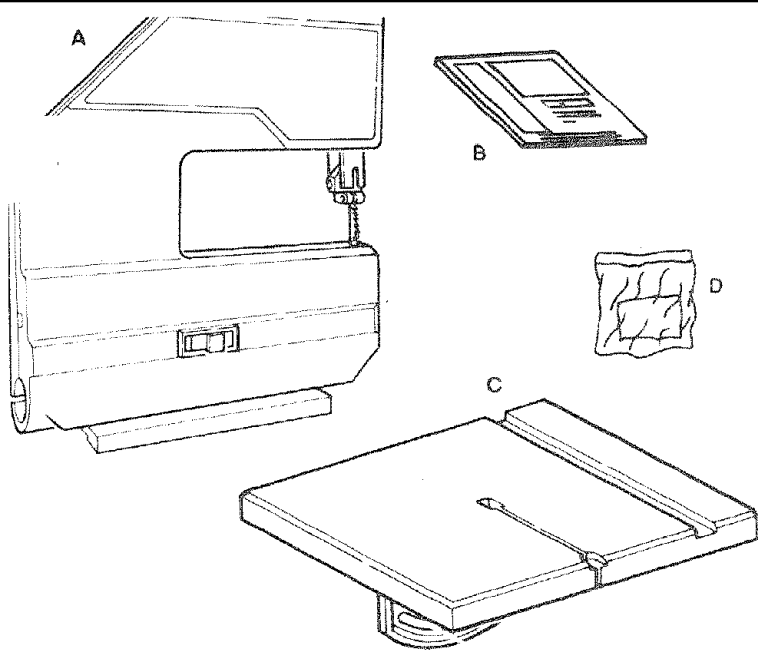

ITEM	TABLE OF LOOSE PARTS	QTY.
A	Basic saw assembly	1
B	Owners Manual	1
C	Saw Table	1
D	Loose Parts Bag	
	Containing the following parts:	
	Key Switch	1
	Wing Nut 1/4-20	1
	Screw, Truss Hd 1/4-20 x 5/8	1
	Wrench, Hex "L" 1/8	1
	Bevel Indicator	1
	Screw, Pan Cross 10-32 x 3/8	1
	Washer 17/64 x 1 x 1/16	1
	Bolt, Carriage 1/4-20 x 1	1
	Knob	1
	Clip Hose	1

assembly

MOUNTING BAND SAW TO WORKBENCH

If band saw is to be used in a permanent location, it should be fastened securely to a firm supporting surface such as a workbench.

If mounting to a workbench, holes should be drilled through supporting surface of the workbench using dimensions illustrated.

1. Each leg should be bolted securely using 5/16" diameter machine screws, lockwashers, and 5/16" hex nuts (not included). Screw length should be 1-3/4" plus the thickness of the bench top.
2. Locate and mark the holes where band saw is to be mounted.
3. Drill (4) 3/8" diameter holes through workbench.
4. Place band saw on workbench aligning holes in feet with holes drilled in workbench.
5. Insert all four 5/16" screws and tighten.

NOTE: All bolts should be inserted from the top. Install the washers and nuts from the underside of the bench.

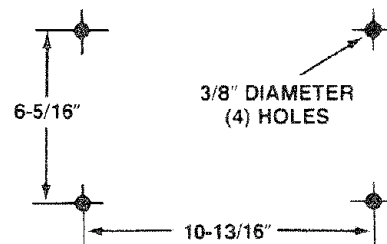

CLAMPING BANDSAW TO WORKBENCH

The Band Saw can be clamped directly to a workbench using two (2) or more "C" clamps on base of unit.

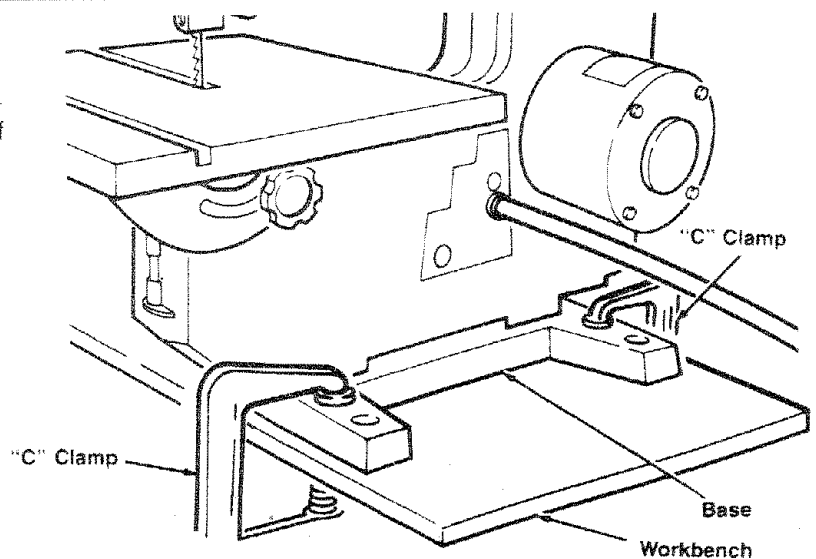

assembly

An alternate method of mounting is to fasten band saw to a mounting board. The board should be of sufficient size to avoid tipping of saw while in use. Any good grade of plywood or chipboard with a 3/4" minimum thickness is recommended. (Thinner chipboard can break.) Once the saw is mounted, securely clamp the board to the workbench using "C" clamps.

WARNING: Supporting surface where band saw is mounted should be examined carefully after mounting to insure that no movement during use can result. If any tipping or walking is noted, secure workbench or supporting surface before operating band saw.

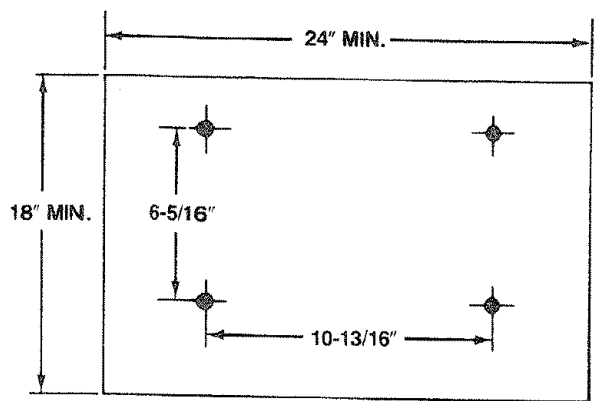

INSTALLING THE TABLE

1. Loosen the upper slide lock knob and position the upper guide assembly all of the way up. Tighten lock knob.

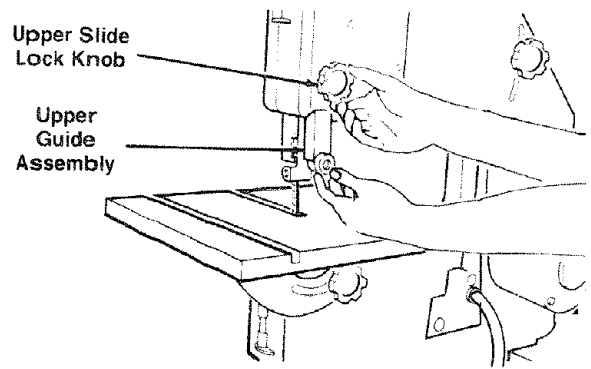

2. Open the front cover of the saw by pulling forward on the finger hold located on the left side of the band saw.

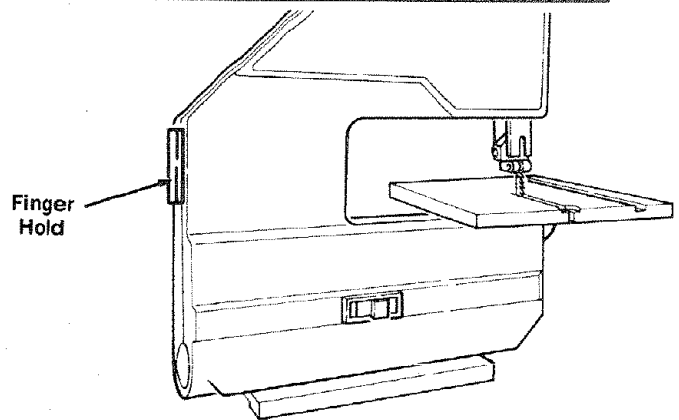

3. Locate the square hole behind the lower right wheel and insert a 1/4-20 x 1" long carriage bolt through this hole from inside the saw.
4. Position the table-trunnion assembly on the back side of the saw so the 1/4-20 x 1" bolt extends through the curved slot in the trunnion. The trunnion should engage the curved mounting rib on the back side of the saw.
5. Install the 1" outside diameter washer and table lock knob to the end of the bolt and tighten by hand.

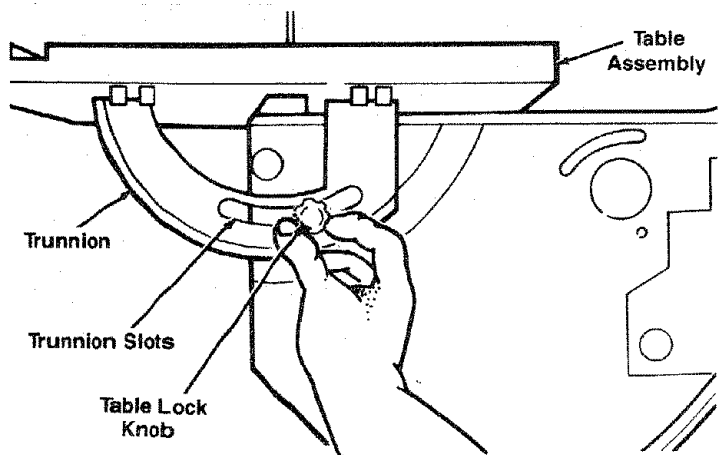

WARNING: Turn off saw, remove switch key and unplug saw before removing or installing blade.

1. Loosen the upper slide lock knob and position the guide assembly about half way between the table and the frame. Tighten the lock knob.
2. Open the front cover of the saw by pulling forward on the finger hold located on the left side of the band saw.
3. Remove the blade guard by loosening the screw located on the side of the guard using a #2 phillips screwdriver. Slide the guard up and pull forward to remove it from the blade guide support.

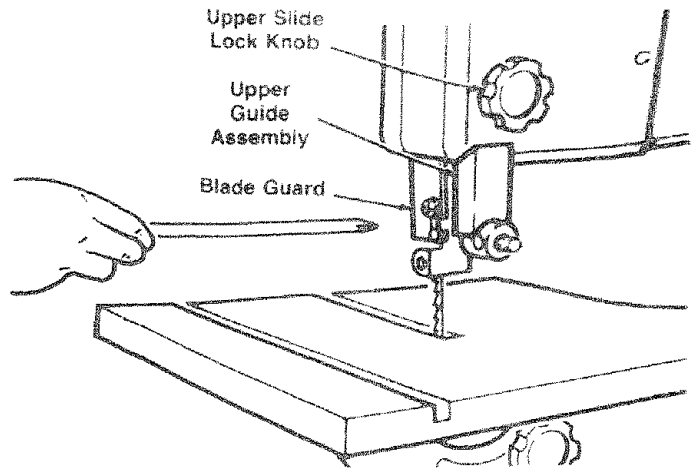

4. Unscrew the upper blade guides using a 1/8 inch hex "L" wrench and separate them about 1/8 inch. Repeat this step for the lower blade guides.

NOTE: There is a patch on the blade guide(s) threads that makes them difficult to turn. This is necessary to prevent rotation of the guides during operation of the saw.

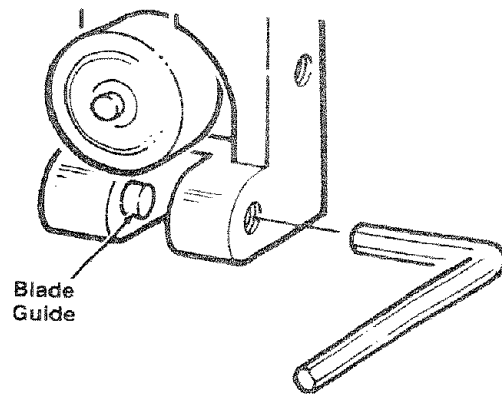

5. Loosen the setscrew which locks the upper blade guide support (located on the left side of the support behind the bearing). Push the support all the way back. Loosen the setscrew holding the upper back-up bearing (located on the right side of the upper slide). Push the bearing all the way back. With the guide support and back-up bearing pushed back, slightly tighten both set screws.

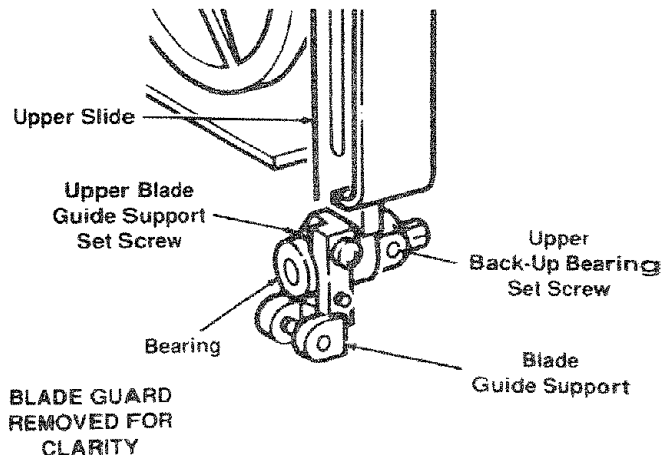

6. Loosen the setscrew which locks the lower blade guide support (accessed through notch in frame located below table). Push the support all the way back. Loosen the setscrew holding the lower back-up bearing. Push the bearing all the way back. With the guide support and back-up bearing pushed back, tighten both set screws.

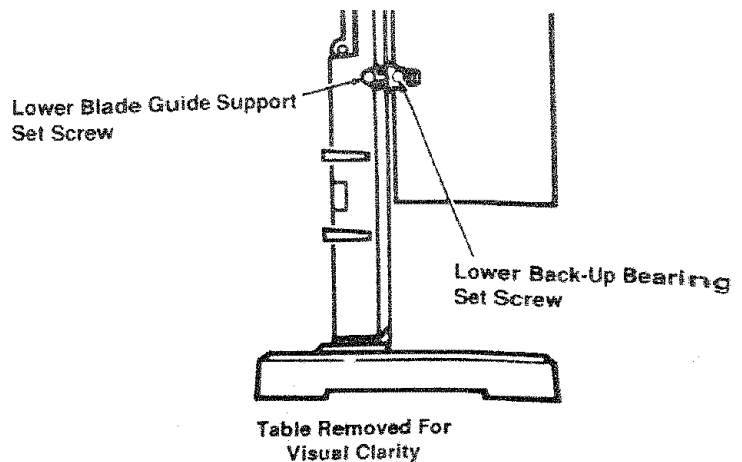

- The upper wheel needs to be placed in its lowest position. Locate the tension lock knob on the back of the saw and turn it counterclockwise approximately two turns. Lift the tension catch away from the teeth and move it to its lowest position.

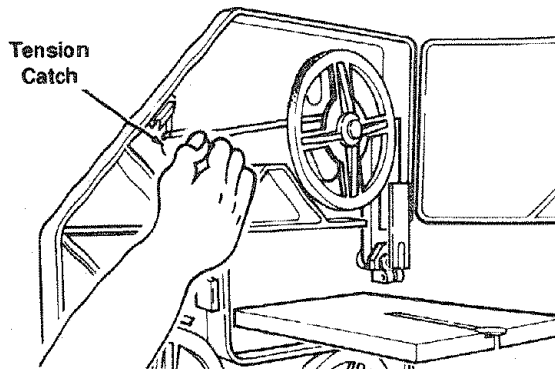

CAUTION: To avoid being scraped, if the blade should suddenly uncoil, wear safety goggles. Carefully uncoil the blade holding it at arms length.

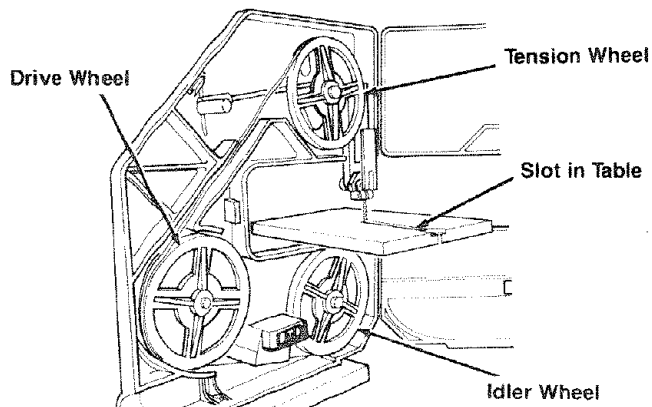

- Uncoil the blade.
- Slide the blade into the slot of the table with the teeth facing forward and down toward the table.
- Place the blade on all three wheels. Center the blade on the rubber tires.

WARNING: Turn off saw, remove switch key and unplug before making any adjustments.

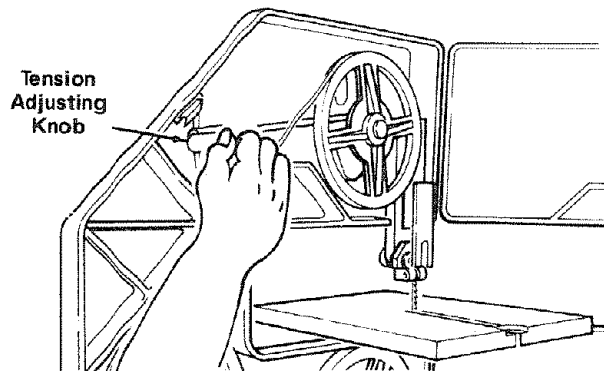

TENSIONING THE BLADE

- With one hand on the knob and the other on the tension catch, lift up on the tension assembly until the slack in the blade is eliminated. Note which notch the top of the tension catch is closest to.

- Continue to pull up on the tension assembly until it has moved two or three notches above where the blade first straightened out. Engage the teeth on the catch into the notches. This is the proper tension for a 1/4" blade.

NOTE: If using an 1/8" blade the tension assembly should be positioned one to two notches above the point where the blade first straightened out.

- Tighten the tension lock knob in order to hold the tension assembly in place.

NOTE: Over tensioning of blade can cause excessive wear of wheel bearings and motor and shorten blade life.

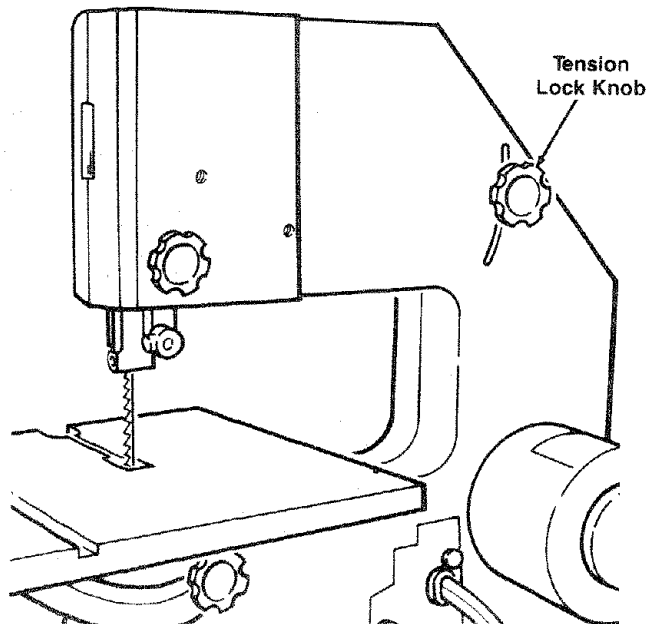

WARNING: Turn off saw, remove switch key and unplug before making any adjustments.

TRACKING THE BLADE

Blade tension must be properly adjusted before tracking the blade.

1. Slowly turn the upper wheel clockwise by hand and watch the blade on the tire. If the blade moves away from the center of the tire the tracking will have to be adjusted.
2. Insert a 1/8" hex wrench into the tracking adjustment screw located on the back of the saw behind the upper wheel.
3. a. If the blade moved toward the front of the saw turn the adjustment screw in (clockwise) while turning the wheel by hand, until the blade rides in the center of the tire.
b. If the blade moved away from the front of the saw turn the adjustment screw out (counter clockwise) while turning the wheel by hand, until the blade rides in the center of the tire.
4. Check the position of the blade on the other tires. The blade should be completely on the tire. If not, adjust the tracking until the blade is on all three tires.
5. Rotate the upper wheel by hand in a clockwise direction for a few more turns. Make sure the blade stays in the same location on the tires. Readjust if necessary, until blade is tracking properly.

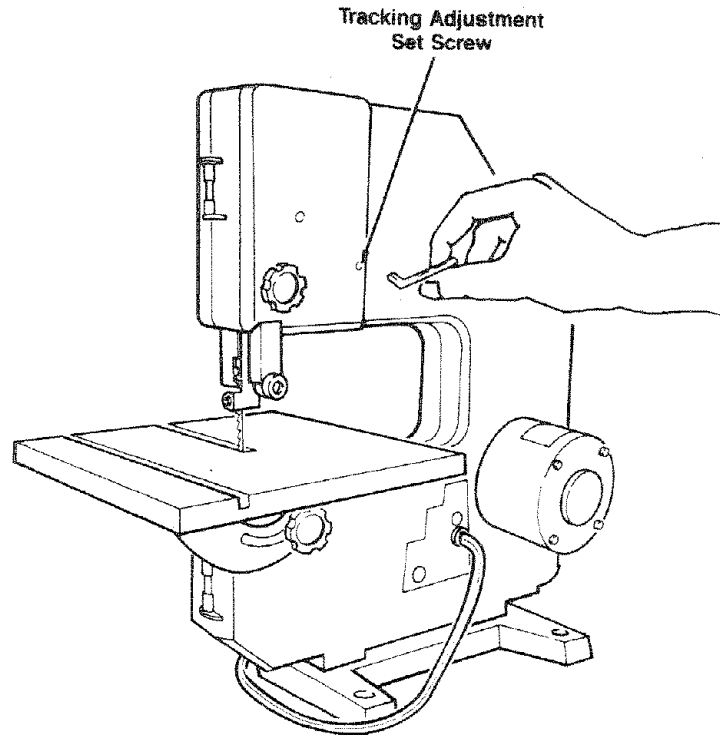

WARNING: Turn off saw, remove switch key and unplug before making any adjustments.

ADJUSTING THE BLADE GUIDES AND BACK-UP BEARING

NOTE: The upper and lower blade guides and back-up bearings support the band saw blade during cutting operations. The adjustment of the guides and bearings should be checked whenever a different blade is installed.

1. Adjust the back-up bearing first. Loosen the rear set screw using a 1/8" hex wrench. (This set screw is located on the right side of the upper slide for the upper bearing and on the right side of the frame just below the table for the lower bearing.)
2. Move the back-up bearing to within 1/32" of the blade. Tighten the rear set screw. Repeat on the other back-up bearing.

NOTE: The back-up bearing is to support the back edge of the blade while cutting. The blade should not contact the bearings when you stop cutting.

3. Adjust the position of the blade guide support next. Loosen the front set screw using a 1/8" hex wrench. (This set screw is located on the left side of the support for the upper guides and the right side for the lower guides.)
4. Slide the blade guide support on the shaft until the front edge of the blade guides are about 1/32" behind the gullet of the blade. Tighten the set screw. Repeat for the other guide.

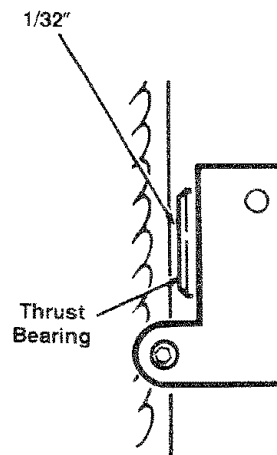

NOTE: Letting the blade teeth hit the blade guides while using the band saw will ruin the blade. The set of the teeth and the sharpened edge of the teeth would be damaged. Proper adjustment of the upper and lower blade guide assemblies will prevent this from happening.

5. Adjust the blade guides last. Use a 1/8" hex wrench to turn the blade guides in or out to where they just clear the side of the blade. Do this for all four guides.

NOTE: There is a patch on the blade guide threads that makes them difficult to turn. This is necessary to prevent rotation of the guides during operation of the saw.

6. Reinstall blade guard and tighten screw.
7. Close the front cover of the saw.

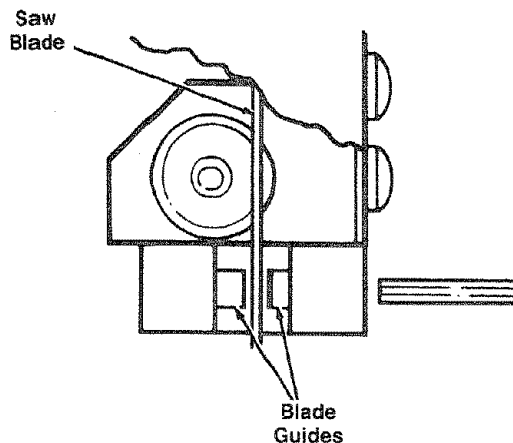

WARNING: Never start the saw with the cover open. Thrown blades can cause injury.

FINAL TABLE ASSEMBLY

1. Close the front cover of the band saw and snap in place.
2. Locate a 1/4-20 x 5/8 truss head screw, and a 1/4-20 wing nut in loose parts. Insert screw into hole in table top as illustrated.
3. From the underside of the table, install wing nut onto the truss head screw and tighten finger tight. This will keep the table flat and in alignment.

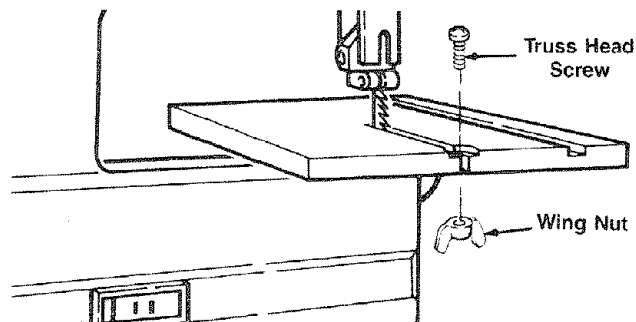

WARNING: Turn off saw, remove switch key and unplug before making any adjustments.

ALIGNING THE TABLE SQUARE TO THE BLADE

1. Loosen the upper slide lock knob and position the guide assembly all the way up. Tighten the lock knob.
2. Loosen table lock knob.
3. Place a small square on the table beside the blade as illustrated.
4. Holding the left edge of the table (near the zero stop set screw), tilt the table up or down to align table 90 degrees to blade (0 degree position). Tighten lock knob.
5. Adjust the zero stop set screw using a 1/8" hex wrench until the set screw just touches the frame.
6. Check squareness of blade to table. Make readjustments if necessary.

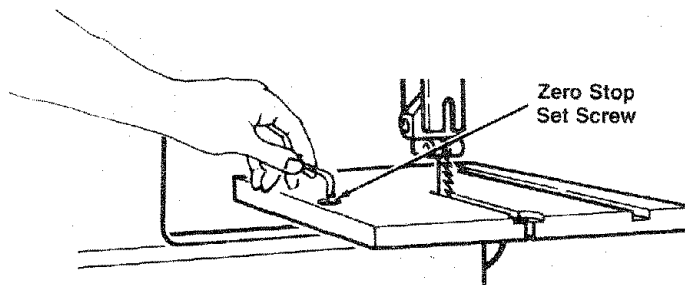
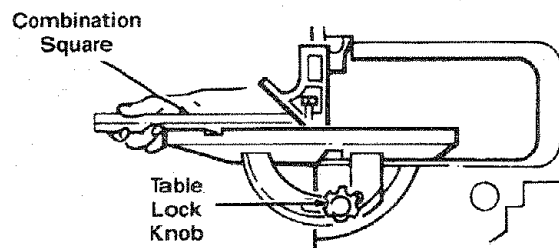

7. Locate the bevel indicator and 10-32 x 3/8" long pan head screw in loose parts bag.
8. Use a #2 phillips screwdriver to attach the bevel indicator to the back of the frame, in the small recess below the trunnion, with the 10-32 x 3/8" screw.
9. Align the bevel indicator with the "0" degree mark on the trunnion and tighten the screw.

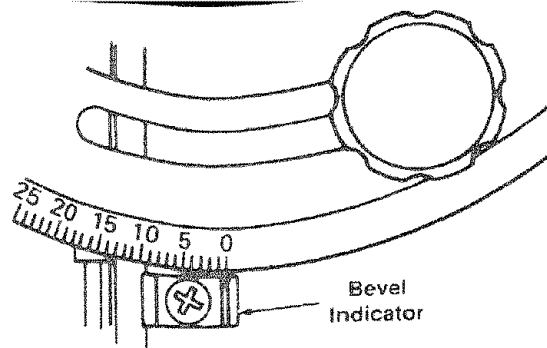

INSTALLING THE HOSE CLIP

1. Locate the Hose Clip in the loose parts bag. Identify the barbs on the clip.

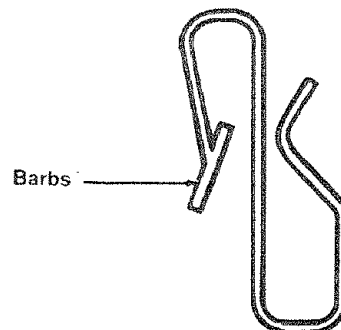

2. Open the front cover of the saw by pulling forward on the finger hold located on the left side of the band saw. Locate the notch in the Frame at the sawdust ejection port.

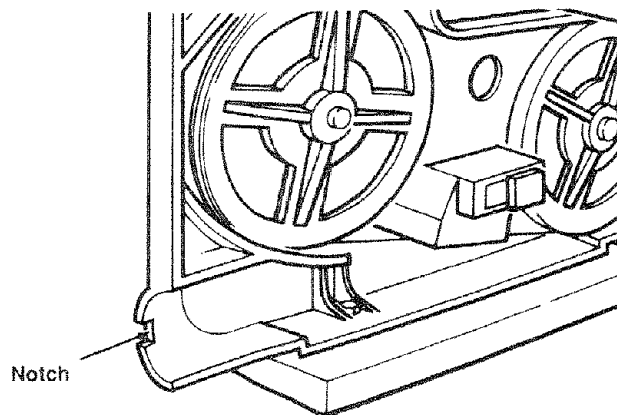

3. Position the Hose Clip with the barbs to the back side of the band saw. Slide the Hose Clip into the notch. Push the clip until it is fully seated on the Frame. The Hose Clip will secure a Wet/Dry vac hose in place for sawdust collection.

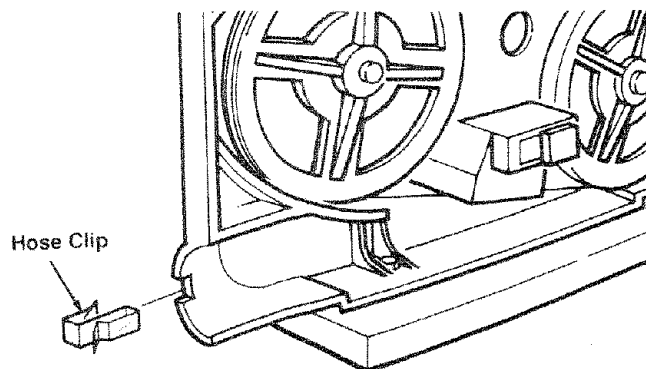

getting to know your band saw

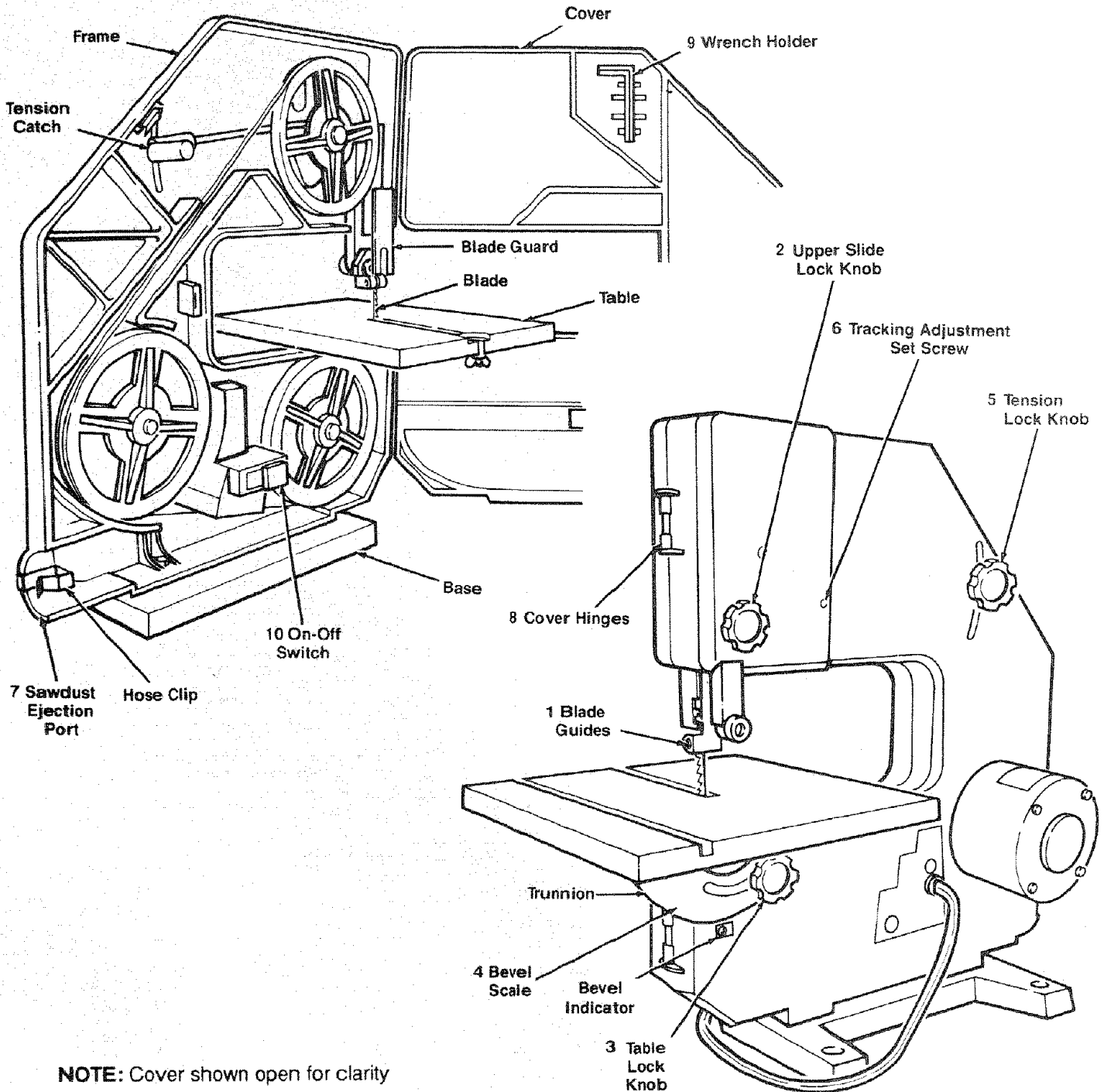

NOTE: Cover shown open for clarity

1. **Blade Guides** . . . Supports the blade and keeps it from twisting during operation. An adjustment is necessary when blades are changed or replaced.
2. **Upper slide lock knob** . . . The upper blade guide assembly should just clear the workpiece while cutting. Always adjust the upper guide assembly and lock the upper slide by tightening the upper slide lock knob before turning on the band saw.
3. **Table lock knob** . . . Loosening the knob allows the table to be tilted and tightening the knob locks the table in place.
4. **Tilt (bevel) scale** . . . Shows degree table is tilted for bevel cutting.
5. **Tension Lock Knob** . . . controls the amount of blade tension when changing blades.
6. **Tracking Adjustment Set Screw** . . . adjust to keep blade running in center of wheels.
7. **Sawdust Ejection Port** . . . sawdust is eliminated from inside of machine. Also, makes an excellent hook-up for a Wet/Dry vac.
8. **Cover Hinges** . . . allows front cover to be opened for making adjustments to machine.

9. **Wrench Holder** . . . Keeps 1/8" Hex "L" Wrench conveniently located for blade guide adjustments.
10. **ON-OFF SWITCH.** The On-Off Switch has a locking feature. THIS FEATURE IS INTENDED TO HELP PREVENT UNAUTHORIZED AND POSSIBLY HAZARDOUS USE BY CHILDREN AND OTHERS.
- a. To turn machine on, insert key into switch.

NOTE: Key is made of yellow plastic; locate in loose parts bag.

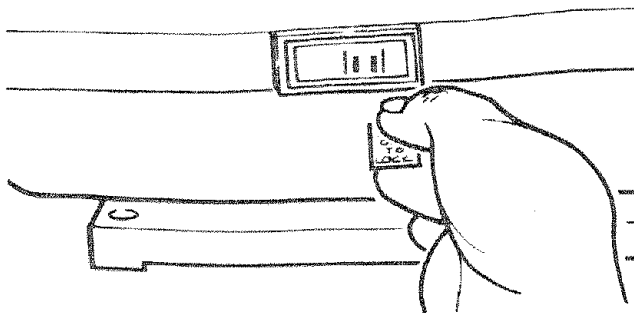

- b. Insert finger under switch lever and pull end of switch out.

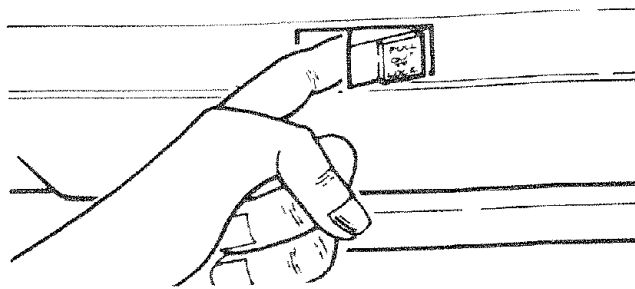

- c. To turn machine OFF . . . PUSH lever in.

NEVER LEAVE THE MACHINE UNATTENDED UNTIL IT HAS COME TO A COMPLETE STOP.

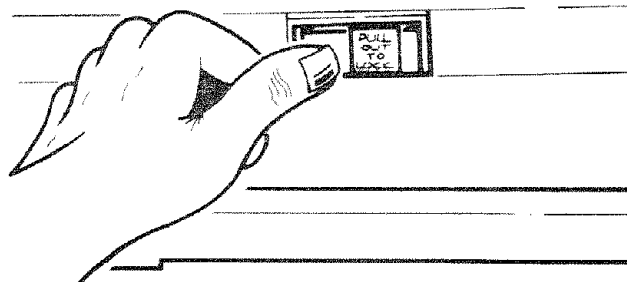

- d. To lock switch in OFF position . . . hold switch IN with one hand . . . REMOVE key with other hand.

WARNING: For your own safety, always lock the switch "OFF" when machine is not in use . . . remove key and keep it in a safe place . . . also . . . in the event of a power failure (all of your lights go out) turn switch off . . . remove the key and store it away from band saw. This will prevent the machine from starting up again when the power comes back on.

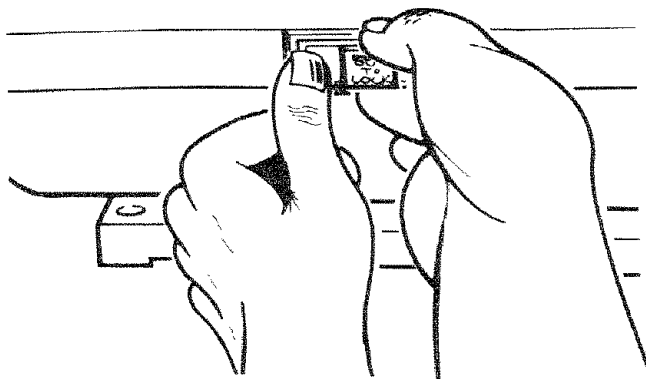

Basic Saw Operations

BEFORE EACH USE:

Inspect your saw.

DISCONNECT THE SAW. To avoid injury from accidental starting, unplug the saw, turn the switch off and remove the switch key before changing the setup, opening covers, removing guards, or blade.

CHECK FOR DAMAGED PARTS. Check for:

- alignment of moving parts,
- binding of moving parts,
- broken parts,
- stable mounting, and
- any other conditions that may affect the way the saw works.

If any part is missing, bent, or broken in any way, or any electrical part doesn't work properly, turn the saw off and unplug the saw. REPLACE damaged, missing, or failed parts before using the saw again.

MAINTAIN TOOLS WITH CARE. Keep the saw clean for best and safest performance.

REMOVE ADJUSTING KEYS AND WRENCHES from tool before turning it on.

To avoid injury from jams, slips or thrown pieces:

- Choose the right size and style blade for the material and the type of cutting you plan to do.
- USE ONLY RECOMMENDED ACCESSORIES. (See page 18). Consult this owner's manual for recommended accessories. Follow the instructions that come with the accessories. The use of improper accessories may cause risk of injury to persons.
- Make sure the blade teeth point downward, toward the table.
- Make sure the blade guides and thrust bearings are properly adjusted.
- Make sure the blade tension is properly adjusted.
- Make sure the table lock knob is tight and no parts have excessive play.

- To avoid accidental blade contact, minimize blade breakage and provide maximum blade support, always adjust the upper blade guide and blade guard to just clear the workpiece.
- KEEP WORK AREA CLEAN. Cluttered areas and benches invite accidents. Floor must not be slippery.

To avoid burns or other fire damage, never use the saw near flammable liquids, vapors or gases.

Plan ahead to protect your eyes, hands, face, ears.

KNOW YOUR SAW. Read and understand the owner's manual and labels affixed to the tool. Learn its application and limitations as well as the specific potential hazards peculiar to this tool.

To avoid injury from accidental contact with moving parts, don't do layout, assembly, or setup work on the saw while any parts are moving.

AVOID ACCIDENTAL STARTING. Make sure switch is "OFF" before plugging saw into a power outlet.

Plan your work.

- USE THE RIGHT TOOL. Don't force tool or attachment to do a job it was not designed to do.
- Use this band saw to cut only wood, wood like products, and plastics.

Dress for safety.

Any power saw can throw foreign objects into the eyes. This can cause permanent eye damage. Wear safety goggles (not glasses) that comply with ANSI Z87.1 (shown on package). Everyday eyeglasses have only impact resistant lenses. They are not safety glasses. Safety goggles are available at Sears retail catalog stores. Glasses or goggles not in compliance with ANSI Z87.1 could seriously hurt you when they break.

- Do not wear loose clothing, gloves, neckties or jewelry (rings, wrist watches). They can get caught and draw you into moving parts.
- Wear nonslip footwear.
- Tie back long hair.
- Roll long sleeves above the elbow.

- Noise levels vary widely. To avoid possible hearing damage, wear ear plugs or muffs when using your saw for hours at a time.
- For dusty operations, wear a dust mask along with the safety goggles.

Inspect your workpiece.

Make sure there are no nails or foreign objects in the part of the workpiece to be cut.

Use extra caution with large, very small or awkward workpieces:

- Use extra supports (tables, saw horses, blocks, etc.) for any workpiece large enough to tip when not held down to the table top.
- NEVER use another person as a substitute for a table extension, or as additional support for a workpiece that is longer or wider than the basic saw table, or to help feed, support or pull the workpiece.
- When cutting irregularly shaped workpieces, plan your work so it will not pinch the blade. A piece of molding, for example, must lay flat or be held by a fixture or jig that will not let it twist, rock or slip while being cut.
- Properly support round material such as dowel rods, or tubing. They have a tendency to roll during a cut, causing the blade to "bite". To avoid this, always use a "V" block or clamp the work to the table.
- Cut only one workpiece at a time.
- Clear everything except the workpiece and related support devices off the table before turning the saw on.

Plan the way you will hold the workpiece from start to finish.

Do not hand hold pieces so small that your fingers will go under the blade guard. Use jigs or fixtures to hold the work and keep your hands away from the blade.

Avoid awkward operations and hand positions where a sudden slip could cause fingers or hand to move into the blade.

DON'T OVERREACH. Keep good footing and balance.

WHENEVER SAW IS RUNNING.

WARNING: Don't let familiarity (gained from frequent use of your band saw) cause a careless mistake. A careless fraction of a second is enough to cause a severe injury.

Before starting your cut, watch the saw while it runs. If it makes an unfamiliar noise or vibrates a lot, stop immediately. Turn the saw off. Unplug the saw. Do not restart until finding and correcting the problem.

KEEP CHILDREN AWAY. Keep all visitors a safe distance from the saw. Make sure bystanders are clear of the saw and workpiece.

DON'T FORCE TOOL. It will do the job better and safer at its designed rate. Feed the workpiece into the saw blade only fast enough to let it cut without bogging down or binding.

Before freeing any jammed material:

- Turn switch "OFF"
- Remove switch key.
- Unplug the saw.
- Wait for all moving parts to stop.

When backing up the workpiece, the blade may bind in the kerf (cut). This is usually caused by sawdust clogging up the kerf or because the blade comes out of the guides. If this happens:

- Turn switch "OFF".
- Remove switch key.
- Unplug saw.
- Wait for all moving parts to stop.
- Open band saw cover.
- Stick flat blade screwdriver or wedge into the kerf.
- Turn the upper wheel by hand while backing up the workpiece.

Before removing loose pieces from the table, turn saw off and wait for all moving parts to stop.

BEFORE LEAVING THE SAW:

Wait for all moving parts to stop.

Make workshop child-proof. Lock the shop. Disconnect master switches. Remove the yellow switch key. Store it away from children and others not qualified to use the tool.

basic band saw operation

A band saw is basically a "curve cutting" machine. It is also used for straight-line cutting operations such as cross cutting, ripping, mitering, beveling, compound cutting, and resawing. It is not capable of doing inside cutting.

This band saw is designed to cut wood and wood like products only.

For general type scroll cutting, follow the pattern lines by pushing and turning the workpiece at the same time. Don't try to turn the workpiece while engaged in the blade without pushing it; the workpiece could bind or twist the blade.

A curve cut is best performed by keeping the pattern line in line with the blade while turning the workpiece **before** the radius of the curve is cut. The blade should cut in the middle of the pattern line (saw kerf) since wood cutting band saw blades are thin.

NOTE: Blade guard is raised and right hand removed for clarity of picture only.

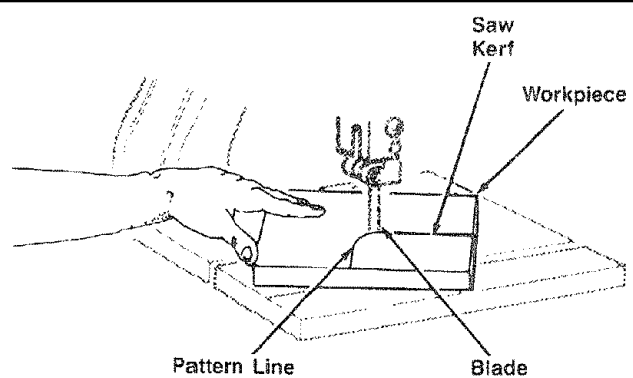

RIGHT - Planning ahead by turning workpiece for cutting a curve.

NOTE: Blade guard is raised and right hand removed for clarity of picture only.

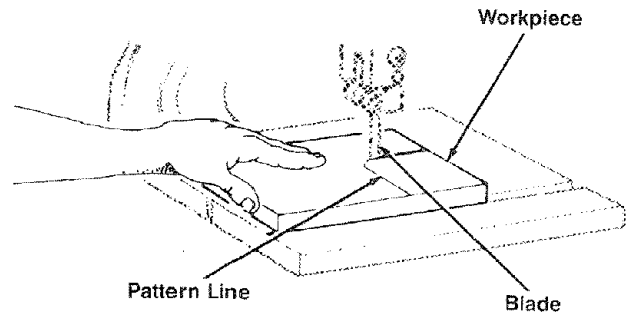

WRONG - Not planning ahead for cutting a curve could bind or twist blade if workpiece is forced.

NOTE: Blade guard is raised and right hand removed for clarity of picture only.

WARNING: To avoid blade contact, adjust the upper guide assembly to just clear the workpiece.

1. Use both hands while feeding the work into the blade. Hold the workpiece firmly against the table. Use gentle pressure. Do not force the work, but allow the blade to cut.
2. The smallest diameter circle that can be cut out is determined by the width of the blade. A 1/4" wide blade will cut a minimum diameter of approximately 1-1/2". A 1/8" wide blade will cut a minimum diameter of approximately 1/2".

Relief cuts are made when an intricate curve (too small a radius for the blade) is to be cut but. A relief cut is made by cutting through the scrap section of workpiece to curve in pattern line, then carefully backing blade out. Several relief cuts should be made for intricate curves, then follow pattern line as sections are cut off of curve "relieving" blade pressure.

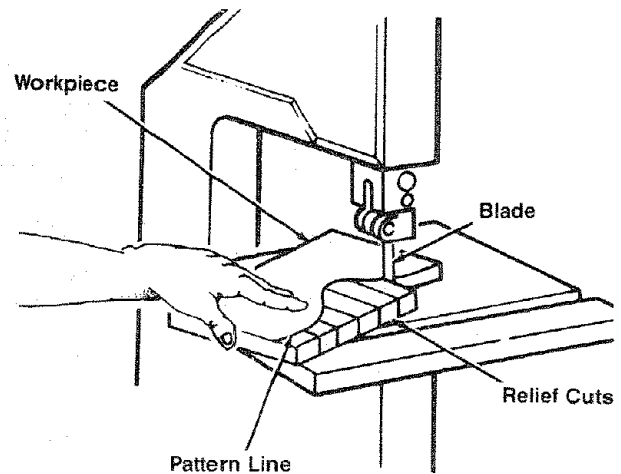

NOTE: Blade guard is raised and right hand removed for clarity of picture only.

maintenance

WARNING: For your own safety, turn switch "OFF", remove switch key and remove plug from power outlet before maintaining or lubricating your band saw.

TIRES

Pitch and sawdust that accumulates on the tires should be removed with a stiff brush or scraped off with a piece of wood. Do not use a sharp knife or any kind of solvent.

GENERAL

Keep your Band Saw clean.

Remove sawdust from the inside frequently.

Do not allow pitch to accumulate on the table, blade guides, or thrust bearings. Clean them with Craftsman Gum and Pitch Remover.

Apply a thin coat of automobile-type wax to the table top so the wood slides easily while cutting. Also apply wax to the inside surfaces of the trunnion.

MOTOR/ELECTRICAL

Frequently vacuum or blow out any sawdust from the motor.

WARNING: If the power cord is worn, cut, or damaged in any way, have it replaced immediately.

WARNING: To avoid fire or electrocution, reassemble electric parts with only approved service parts. Reassemble exactly as originally assembled.

LUBRICATION

All of the BALL BEARINGS are permanently lubricated. They require no further lubrication.

Wiring Diagram

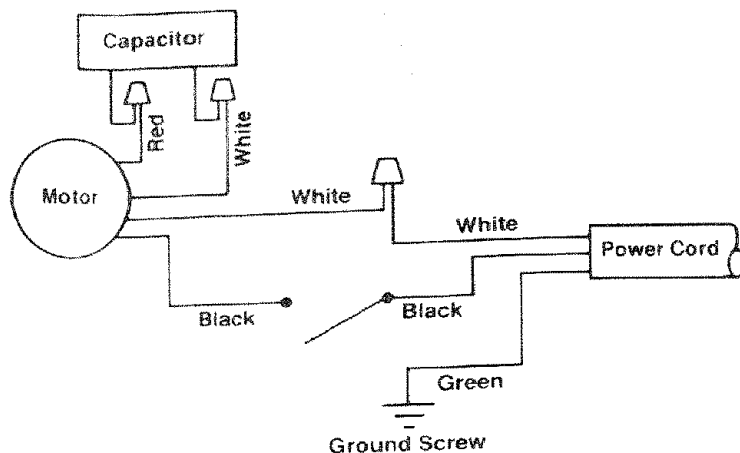

sears recommends the following accessories

Sears may recommend other accessories not listed in manual.

See your nearest Sears Store or Catalog Department for other accessories.

Do not use any accessory unless you have received and read complete instructions for its use.

Item	Cat. No.
Miter Gauge	9-24214
Blades (56-7/8" length).....	See Catalog
Leg Set	9-22244
Power Tool Handbook.....	9-29117

troubleshooting

WARNING: For your own safety, turn switch "OFF", remove switch key and remove plug from power outlet before readjusting or aligning your band saw.

TROUBLE	PROBABLE CAUSE	REMEDY
Motor will not run.	<ol style="list-style-type: none"> 1. Defective On-Off switch. Defective power cord. 2. Motor Defective. 	<ol style="list-style-type: none"> 1. Replace defective parts before using Band Saw again. 2. Consult Sears Service. Any attempt to repair this motor may create a HAZARD unless repair is done by a qualified service technician. Repair service is available at your nearest Sears Store.
Blade does not run in the approximate center of the upper wheel.	<ol style="list-style-type: none"> 1. Not tracking properly. 	<ol style="list-style-type: none"> 1. Adjust tracking, see Assembly Section, "Tracking the Blade."
Band Saw slows down when cutting.	<ol style="list-style-type: none"> 1. Cutting too small a radius. 2. Dull blade. 	<ol style="list-style-type: none"> 1. Stop feeding, and back up the material slightly, until the band saw speeds up. 2. Replace blade.
Blades breaking.	<ol style="list-style-type: none"> 1. Too much tension. 2. Kink in blade caused by cutting too small a radius or turning the material too fast when cutting. 	<ol style="list-style-type: none"> 1. Adjust tension. See Assembly section "Tensioning The Blade." 2. Use correct cutting technique. See Basic Band Saw Operation Section.
Saw is noisy when running.	<ol style="list-style-type: none"> 1. Too much blade tension 2. Blade guides and back-up bearings are in contact with the blade. 	<ol style="list-style-type: none"> 1. Adjust blade tension. See Assembly section "Tensioning The Blade." 2. Adjust upper and lower blade guides and bearings. See assembly section "Adjusting the Blade Guides and Back-up Bearing."
Blade will not cut straight.	<ol style="list-style-type: none"> 1. Blade guides and bearings not properly adjusted. 2. Worn or defective blade. 	<ol style="list-style-type: none"> 1. Adjust upper and lower blade guides and bearings. See Assembly section "Adjusting Guides and Back-up Bearing." 2. Replace blade.
Blade guides will not stay in position	<ol style="list-style-type: none"> 1. Patch on blade guide threads has deteriorated allowing them to rotate with the blade. 	<ol style="list-style-type: none"> 1. Replace blade guides.

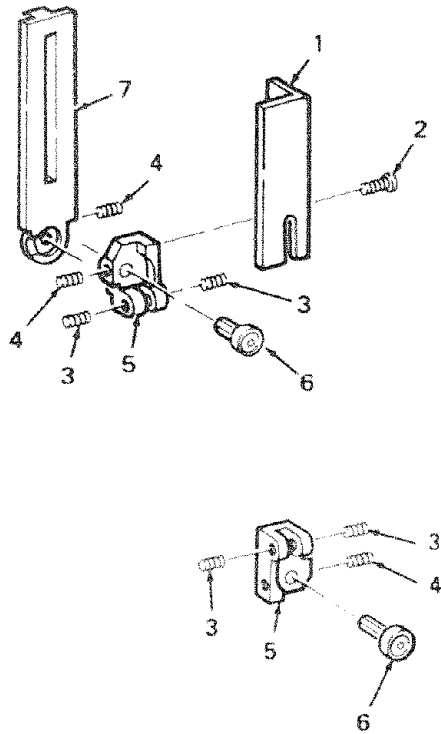

FIGURE 1

Key No	Part No.	Description
1	820286	Guard Blade
2	STD601103	Scr Pan HD TY "TT" 10-32 x 3/8
3	817899	Scr Soc Set 1/2 Dog Pt. 1-4-20 x 1/2
4	STD502502	Scr Soc Set 1/4-20 x 1/4
5	820279	Suport Guide
6	820281	Shaft w/Bearing
7	820284	Slide Upper

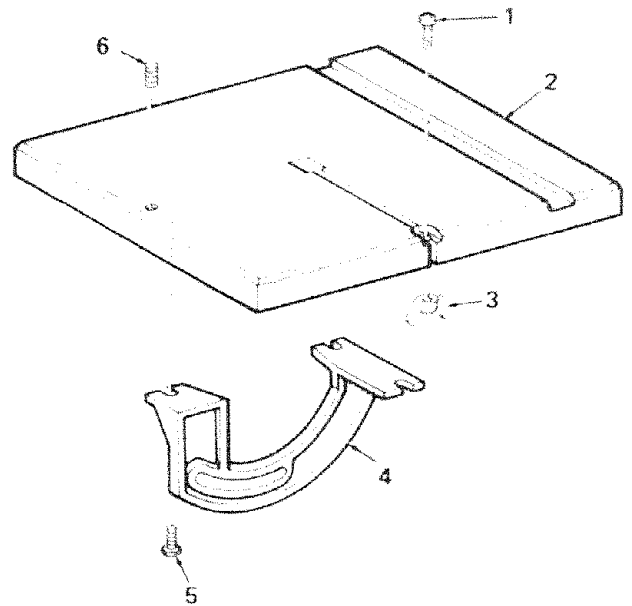
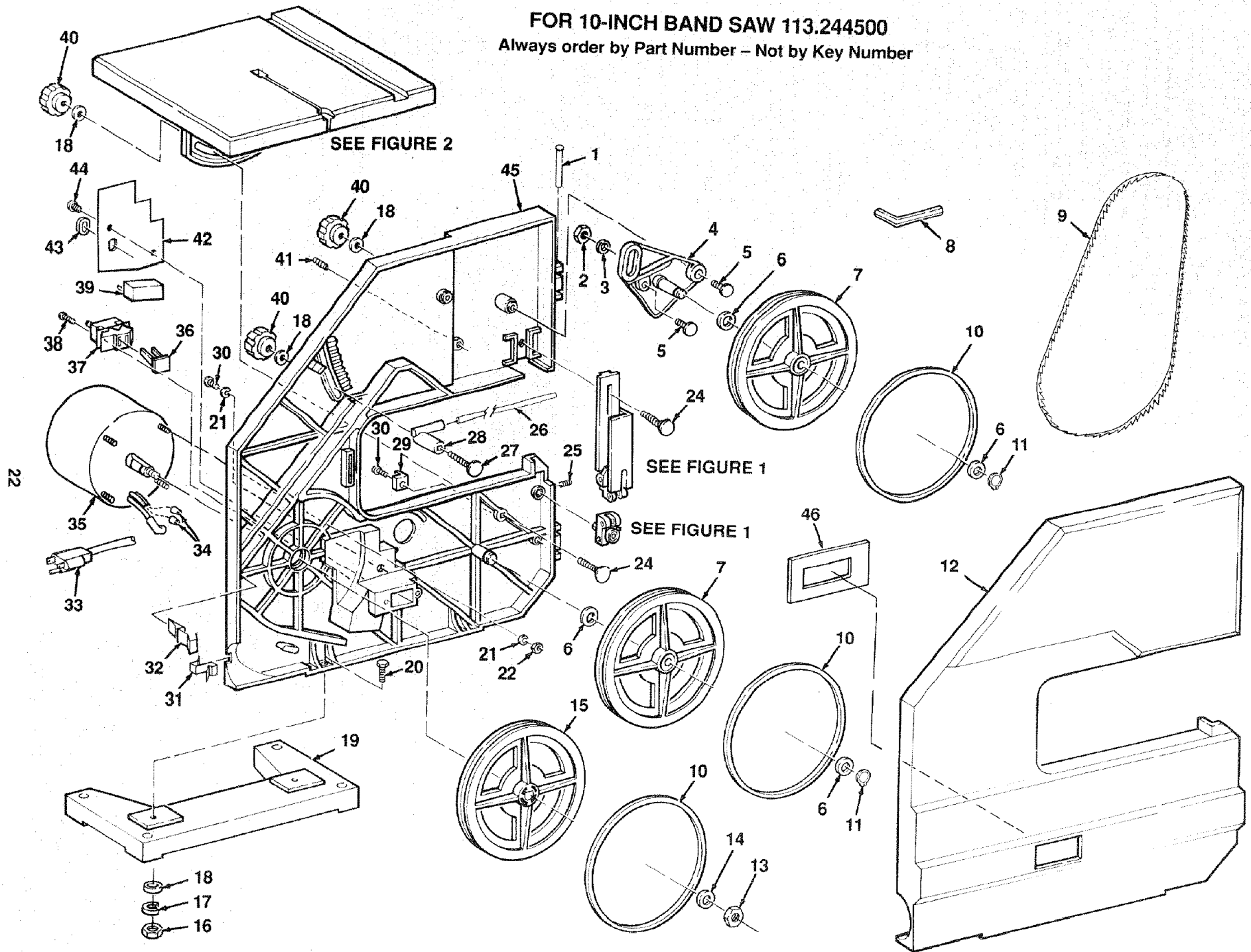

FIGURE 2

Key No	Part No.	Description
1	60530	Scr Truss 1/4-20 x 5/8
2	817935	Table
3	820874	Nut Wing Low Profile 1/4-20
4	817915	Trunnion
5	815865-2	Scr Hx Hd TYTT 1/4-20 x 5/8
6	817149	Scr Locking Set 1/4-20

FOR 10-INCH BAND SAW 113.244500
Always order by Part Number – Not by Key Number



FOR 10-INCH BAND SAW 113.244500
Always order by Part Number – Not by Key Number

FIGURE 1

repair parts

Key No	Part No.	Description
1	820288	Pin Hinge
2	STD541031	Nut, Hex 5/16-18
3	STD551131	Lockwasher 5/16
4	820269	Support Wheel
5	816087	Scr Tr Cr Hd 1/4-20 x 1/2
6	818146	Washer Nylon
7	820266	Wheel Idler (Includes Key No. 10)
8	9-28137	* Wrench, Hex L 1/8
9	9-26653	†Band Saw Blade 56-7/8
10	817911	BandsawTire
11	817453-2	Retaining Ring
12	820287	Cover Front (Includes Key No. 46)
13	817943	* Nut 3/8-16 L.H.
14	STD551037	* Washer 3/8 x 3/4 x 1/32
15	820277	Wheel Drive (Includes Key No. 10)
16	STD541025	* Nut, Hex 1/4-20
17	STD551225	* Lockwasher 1/4
18	STD551025	* Washer 17/64 x 1 x 1/16
19	820265	Foot Frame
20	STD522507	* Screw Hex Hd 1/4-20 x 3/4
21	STD551210	* Lockwasher Int N10
22	STD541110	* Nut, Hex 10-32
24	STD532510	* Bolt Crge 1/4-20x1

Key No	Part No.	Description
25	STD502502	* Screw Soc. Set 1/4-20 x 1/4
26	820272	Spring Blade Tension
27	STD532525	* Bolt Crge 1/4-20 x 2-1/2
28	820088	Catch Blade Tension
29	817944	Indicator Bevel
30	STD511103	* Screw Pan HD 10-32 x 3/8
31	820493	Clip Hose
32	816464	Latch Cover
33	813989-1	Cord w/Plug
34	STD375006	* Connector Wire
35	820273	Motor
36	9-22256	†Key Switch
37	816113	Switch Locking
38	STD600803	* Screw Pan HD TY "TT" 8-32 x 3/8
39	820274	Capacitor
40	61400	Knob 1-3/8 Dia.
41	817149	Screw Lock Set 1/4-20
42	820276	Plate Cover
43	69164	Relief-Strain
44	STD512505	Screw Pan HD 1/4-20 x 1/2
45	820261	Frame
46	821157	Gasket
-	SP5492	Owners Manual (Not Illustrated)

†Stock Item – May Be Secured Through The Hardware Department Of Most Sears Retail Stores Or Catalog Order Houses.

* Standard Hardware Item – May Be Purchased Locally.

SEARS

**owners
manual**

SERVICE

**MODEL NO.
113.244500**

10-INCH BAND SAW

**HOW TO ORDER
REPAIR PARTS**

10-INCH BAND SAW

Now that you have purchased your 10-Inch Band Saw, should a need ever exist for repair parts or service, simply contact any Sears Service Center and most Sears, Roebuck and Co. stores. Be sure to provide all pertinent facts when you call or visit.

The model number of your 10-Inch Band Saw will be found on a plate located on the back of the Band Saw below the motor.

WHEN ORDERING REPAIR PARTS, ALWAYS GIVE THE FOLLOWING INFORMATION:

PART NUMBER	PART DESCRIPTION
MODEL NUMBER 113.244500	NAME OF ITEM 10-Inch Band Saw

All parts listed may be ordered from any Sears Service Center and most Sears stores. If the parts you need are not stocked locally, your order will be electronically transmitted to a Sears Repair Parts Distribution Center for handling.

Sold by SEARS, ROEBUCK AND CO., Chicago, IL 60684 U.S.A.