

Save This Manual For
Future Reference

SEARS

*owners
manual*

**MODEL NO.
113.236180
SCROLL SAW
Variable Speed**

Serial
Number _____

Model and serial number may be found
attached to the underside of the work-
table.

You should record both model and
serial number in a safe place for future
use.

**FOR YOUR
SAFETY:
READ ALL
INSTRUCTIONS
carefully.**

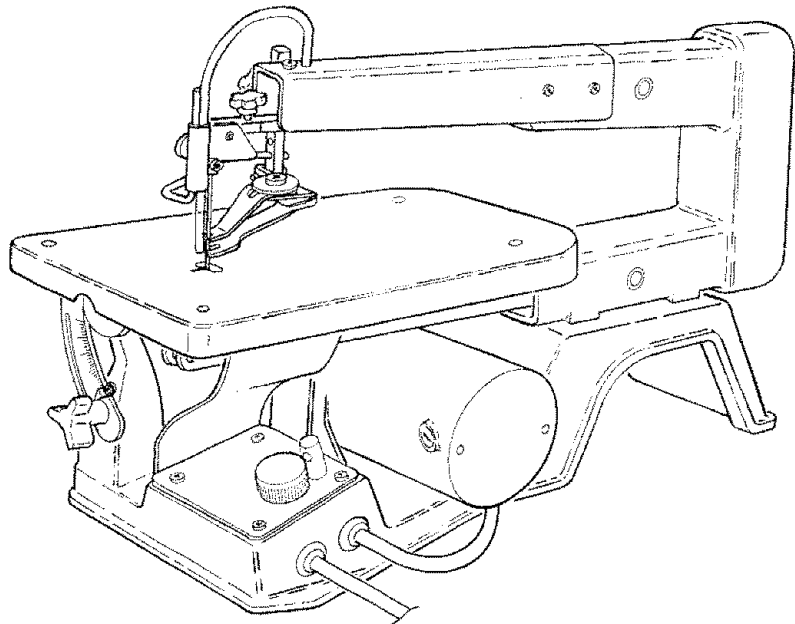

CRAFTSMAN
16" VARIABLE SPEED
ELECTRONIC
SCROLL SAW

- *assembly*
- *operating*
- *repair parts*

Sold by SEARS, ROEBUCK AND CO., Chicago, IL. 60684 U.S.A.

FULL ONE YEAR WARRANTY ON CRAFTSMAN SCROLL SAW

If within one year from the date of purchase, this Craftsman Scroll Saw fails due to a defect in material or workmanship, Sears will repair it, free of charge.

WARRANTY SERVICE IS AVAILABLE BY SIMPLY CONTACTING THE NEAREST SEARS SERVICE CENTER/DEPARTMENT THROUGHOUT THE UNITED STATES.

This warranty applies only while this product is used in the United States.

This warranty gives you specific legal rights and you may also have other rights which vary from state to state.

SEARS, ROEBUCK AND CO., DEPT. 698/731A Sears Tower, Chicago, IL 60684

general safety instructions for power tools

- 1. KNOW YOUR POWER TOOL**
Read and understand the owner's manual and labels affixed to the tool. Learn its application and limitations as well as the specific potential hazards peculiar to this tool.
- 2. GROUND ALL TOOLS**
This tool is equipped with an approved 3-conductor cord and a 3-prong grounding type plug to fit the proper grounding type receptacle. The green conductor in the cord is the grounding wire. Never connect the green wire to a live terminal.
- 3. KEEP GUARDS IN PLACE**
— in working order, and in adjustment and alignment.
- 4. REMOVE ADJUSTING KEYS AND WRENCHES**
Form a habit of checking to see that keys and adjusting wrenches are removed from tool before turning it on.
- 5. KEEP WORK AREA CLEAN**
Cluttered areas and benches invite accidents. Floor must not be slippery due to wax or sawdust.
- 6. AVOID DANGEROUS ENVIRONMENT**
Don't use power tools in damp or wet locations or expose them to rain. Keep work area well lighted. Provide adequate surrounding work space.
- 7. KEEP CHILDREN AWAY**
All visitors should be kept a safe distance from work area.
- 8. MAKE WORKSHOP CHILD PROOF**
— with padlocks, master switches, or by removing starter keys.
- 9. DON'T FORCE TOOL**
It will do the job better and safer at the rate for which it was designed.
- 10. USE RIGHT TOOL**
Don't force tool or attachment to do a job it was not designed for.
- 11. WEAR PROPER APPAREL**
Do not wear loose clothing, gloves, neckties or jewelry (rings, wristwatches) to get caught in moving parts. NONSLIP footwear is recommended. Wear protective hair covering to contain long hair. Roll long sleeves above the elbow.
- 12. USE SAFETY GOGGLES (Head Protection)**
Wear safety goggles (must comply with ANSI Z87.1) at all times. Everyday eyeglasses only have impact resistant lenses, they are NOT safety glasses'. Also, use face or dust mask if cutting operation is dusty, and ear protectors (plugs or muffs) during extended periods of operation.
- 13. SECURE WORK**
Use clamps or a vise to hold work when practical. It's safer than using your hands and frees both hands to operate tool.
- 14. DON'T OVERREACH**
Keep proper footing and balance at all times.
- 15. MAINTAIN TOOLS WITH CARE**
Keep tools sharp and clean for best and safest performance. Follow instructions for lubricating and changing blades, bits, cutters, etc.
- 16. DISCONNECT TOOLS**
— before servicing; when changing accessories such as blades, bits, cutter, etc.
- 17. AVOID ACCIDENTAL STARTING**
Make sure switch is in "OFF" position before plugging in power cord.

- 18. USE RECOMMENDED ACCESSORIES**
Consult the owner's manual for recommended accessories. Follow the instructions that accompany the accessories. The use of improper accessories may cause hazards.
- 19. NEVER STAND ON TOOL**
Serious injury could occur if the tool is tipped or if the cutting tool is accidentally contacted.
- Do not store materials above or near the tool such that it is necessary to stand on the tool to reach them.
- 20. CHECK DAMAGED PARTS**
Before further use of the tool, a guard or other part that is damaged should be carefully checked to

ensure that it will operate properly and perform its intended function. Check for alignment of moving parts, binding of moving parts, breakage of parts, mounting, and any other conditions that may affect its operation. A guard or other part that is damaged should be properly repaired or replaced.

- 21. DIRECTION OF FEED**
Feed work into a blade or cutter against the direction of rotation of the blade or cutter only.
- 22. NEVER LEAVE TOOL RUNNING UNATTENDED**
Turn power off. Don't leave tool until it comes to a complete stop.

additional safety instructions for scroll saw

Safety is a combination of operator common sense and alertness at all times when the scroll saw is being used.

WARNING: FOR YOUR OWN SAFETY, DO NOT ATTEMPT TO OPERATE YOUR SCROLL SAW UNTIL IT IS COMPLETELY ASSEMBLED AND INSTALLED ACCORDING TO THE INSTRUCTIONS... AND UNTIL YOU READ AND UNDERSTAND THE FOLLOWING.

Page

1. General Safety Instructions for Power Tools2
2. Assembly7
3. Basic Scroll Saw Operation14
4. Maintenance16

5. Stability of Machine.

Your scroll saw must be bolted securely to stand or work bench. In addition, if there is any tendency for the scroll saw to move during certain operations, bolt your scroll saw stand or workbench to the floor.

6. Location

To avoid fire or explosions, never use this tool where flammable vapors or gases are in the air. To avoid injury from dropped unit, unplug saw before moving it. This scroll saw is intended for indoor use only.

7. Protection: Eyes, Hands, Face, Ears, Body

A. To avoid being pulled into the blade:

1. Roll long sleeves above elbows
2. Do not wear:
 - a. Gloves
 - b. Jewelry
 - c. Ties or other loose clothing
3. Tie back long hair

- B. Do not cut pieces of material too small to hold by hand outside the blade guard/hold down.
- C. Avoid awkward hand positions where a sudden slip could cause a hand to move into the blade.
- D. To avoid slips due to lifting of the work piece make sure the blade teeth point downward toward the table.
- E. To avoid blade breakage always adjust blade tension correctly.
- F. To avoid losing control of the work piece or tool:
 1. When cutting a large piece of material make sure it is fully supported at table height.
 2. Hold the work piece firmly against the table.
 3. Do not feed the material too fast while cutting. Only feed the material fast enough so that the blade will cut.
 4. Use caution when cutting off material which is irregular in cross section and could pinch the blade before the cut is completed. A piece of molding, for example, must lay flat on the table and not be permitted to rock while being cut.
 5. Use caution when cutting off round material such as dowel rods, or tubing. They have a tendency to roll while being cut causing the blade to bite. Use a V-block to control the piece.
- G. When backing the blade out of the workpiece, the blade may bind in the kerf (cut) . . . this is usually caused by sawdust clogging up the kerf. If this happens: Turn off the scroll saw . . . remove plug from power source outlet . . . wedge open the kerf . . . back the blade out of the workpiece.
- H. To avoid unsupervised work, use or accidents due to inattention:
 1. Never leave the scroll saw work area with the power on, before the machine has come to a complete stop.
 2. Do not perform layout, assembly or set up work on the table while the cutting tool is in operation.

3. Turn saw "OFF" and remove plug from power supply outlet before installing or removing an accessory attachment.
4. Never turn your scroll saw "ON" before clearing the table of all objects: (tools, scraps of wood, etc.) except for the work piece and related feed or support devices for the operation planned.
8. Should any part of this scroll saw be missing, bent, or fail in any way, or any electrical component fail to perform properly, shut off power switch and remove plug from power supply outlet. Replace damaged, missing, and/or failed parts before resuming operation.
9. **Think Safety.**
Safety is a combination of operator common sense and alertness whenever the scroll saw is in operation.

The operation of any power tool can result in foreign objects being thrown into the eyes, which can result in severe eye damage. Always wear safety goggles complying with ANSI Z87.1 (shown on Package) before commencing power tool operation. Safety goggles are available at Sears retail or catalog stores.

WARNING: ALWAYS KEEP ALERT. DO NOT ALLOW FAMILIARITY (GAINED FROM FREQUENT USE OF YOUR SCROLL SAW) TO CAUSE A CARELESS MISTAKE. ALWAYS REMEMBER THAT A CARELESS FRACTION OF A SECOND IS SUFFICIENT TO INFLICT SEVERE INJURY.



DANGER

FOR YOUR OWN SAFETY:

Read and understand owner's manual before operating Scroll Saw.

- ALWAYS wear SAFETY GOGGLES complying with ANSI Z87.1.
- PROPERLY ADJUST HOLDDOWN.
- Hold workpiece down firmly.
- Turn saw off and LOCK SWITCH before adjusting saw, changing blade or leaving area.
- When INSTALLING BLADE: Blade teeth must point down. Tension blade by turning knob clockwise one full turn beyond take-up of slack. Follow complete installation and checking procedure in owner's manual.

Electrical: 120 volts
60 Hz AC only, 1.2 amps



E123036

electrical connections

WARNING: TO AVOID ELECTRICAL HAZARDS, FIRE HAZARDS, OR DAMAGE TO THE TOOL, USE PROPER CIRCUIT PROTECTION. YOUR SAW IS WIRED AT THE FACTORY FOR 120V OPERATION. CONNECT TO A 120-V, 15-AMP, BRANCH CIRCUIT AND USE A 15-AMP FUSE OR CIRCUIT BREAKER. TO AVOID SHOCK OR FIRE, IF POWER CORD IS WORN OR CUT, OR DAMAGED IN ANY WAY, HAVE IT REPLACED IMMEDIATELY.

IF NOT PROPERLY GROUNDED THIS POWER TOOL CAN CAUSE ELECTRICAL SHOCK - PARTICULARLY WHEN USED IN DAMP LOCATIONS CLOSE TO PLUMBING. IF AN ELECTRICAL SHOCK OCCURS THERE IS ALSO THE POTENTIAL OF A SECONDARY HAZARD SUCH AS YOUR HANDS CONTACTING THE SAWBLADE. NOT ALL OUTLETS ARE PROPERLY GROUNDED. IF YOU ARE NOT SURE THAT YOUR OUTLET IS PROPERLY GROUNDED, HAVE IT CHECKED BY A QUALIFIED ELECTRICIAN.

Your unit has a plug that looks like the one shown.

This power tool is equipped with a 3-conductor cord and ground type plug listed by Underwriters' Laboratories.

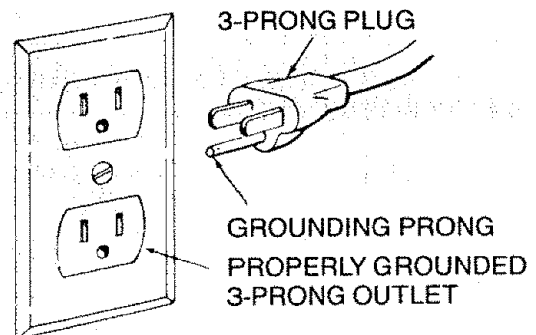

The ground conductor has a green jacket and is attached to the tool housing at one end and to the ground prong in the attachment plug at the other end.

This plug requires a mating 3-conductor grounded type outlet as shown above.

WARNING: TO MAINTAIN PROPER TOOL GROUNDING WHENEVER THE OUTLET YOU ARE PLANNING TO USE FOR THIS POWER TOOL IS OF THE TWO PRONG TYPE, DO NOT REMOVE OR ALTER THE GROUNDING PRONG IN ANY MANNER. USE AN ADAPTER AS SHOWN AND ALWAYS CONNECT THE GROUNDING PRONG TO KNOWN GROUND.

It is recommended that you have a qualified electrician replace the two prong outlet with a properly grounded three prong outlet.

An adapter as shown is available for connecting the plug to 2-prong receptacles. The green grounding lead extending from the adapter must be connected to a permanent ground such as a properly grounded outlet box.

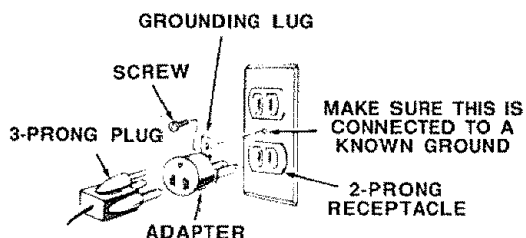

WARNING: THE ADAPTER ILLUSTRATED IS FOR USE ONLY IF YOU ALREADY HAVE A PROPERLY GROUNDED 2-PRONG RECEPTACLE.

MOTOR SAFETY PROTECTION

1. This tool should be connected to a 120V, 15 amp branch circuit with a 15 amp fuse or circuit breaker. Failure to use the proper size fuse can result in damage to the motor.
2. If the motor fails to start, control knob should be pushed down to "OFF" position immediately. **UNPLUG THE TOOL.** Check the saw blade to make sure it operates freely. If the blade is free, try to start the motor again. If the motor still does not start, refer to the "Motor Troubleshooting Chart."
3. If the motor suddenly stalls while cutting wood, turn the power switch off, unplug the tool, and free the blade from the wood. The motor may now be re-started and the cut finished.
4. Frequent "blowing" of fuses or tripping of circuit breakers may result if:

- a. **MOTOR IS OVERLOADED** - Overloading can occur if you feed too rapidly.
- b. **LOW VOLTAGE** - Although the motor is designed for operation on the voltage and frequency specified on the motor nameplate, normal loads will be handled safely on voltages not more than 10% above or below the nameplate voltage. Heavy loads, however, require that voltage at motor terminals equals the voltage specified on nameplate.

5. Most motor troubles may be traced to loose or incorrect connections, overload, reduced input voltage (such as small size wire in the supply circuit) or to overly long supply circuit wire. Always check the connections, the load and the supply circuit whenever motor fails to perform satisfactorily. Check wire size and length with the "Wire Size Chart" below.

WIRE SIZES

The use of any extension cord will cause some loss of power. To keep this to a minimum and to prevent overheating and motor burn-out, use the table below to determine the minimum wire size (A.W.G.) extension cord. Use only 3-wire extension cords which have 3-prong grounding type plugs and 3-pole receptacles which accepts the tools plug.

CAUTION: For circuits that are farther away from electrical service box, the wire size must be increased proportionately in order to deliver ample voltage to the saw motor.

Length of the Conductor	120 Volts Wire Sizes Required (American Wire Gage Number)
0 - 25 Ft.	16
26 - 50 Ft.	14
51 - 100 Ft.	12

glossary of terms for woodworking

1. **Kerf** - the slot cut by the blade
2. **Leading Edge** - the edge of the workpiece which is pushed into the blade first.
3. **Sawblade Path** - The area of the workpiece directly in line with and moving toward the sawblade edge.
4. **Blade Tooth Set** - the distance that the edge of the sawblade tooth is bent (on set) outward from the side of the blade.
5. **Trailing Edge** - the workpiece edge last cut by the sawblade.
6. **Workpiece** - the item on which the cutting operation is being performed.

contents

	page		
Warranty Information	2	Getting to Know Your Scroll Saw	12
General Safety Instructions for Power Tools	2	Choice of Blade and Speed	13
Additional Safety Instruction for Scroll Saws	3	Operation	14
Electrical Information	4	Making Interior Cuts	14
Glossary of Terms for Woodworking	5	Mounting an Auxiliary Surface for the Work Table	15
Unpacking & Checking Contents	6	Maintenance	16
Assembly	7	Recommended Accessories	16
Setting the Table for Horizontal or Bevel Cutting	7	Troubleshooting	17
Aligning the Bevel Indicator	8	Wiring Diagram	17
Mounting the Scroll Saw	9	Repair Parts	18
Removing and Installing Blades	10	Service Information	20

unpacking and checking contents

TOOLS NEEDED

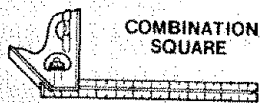

COMBINATION SQUARE



MEDIUM PHILLIPS SCREWDRIVER

WARNING: FOR YOUR OWN SAFETY, NEVER CONNECT PLUG TO POWER SOURCE OUTLET UNTIL ALL ASSEMBLY STEPS ARE COMPLETE, AND YOU HAVE READ AND UNDERSTAND THE SAFETY AND OPERATIONAL INSTRUCTIONS.

CAUTION: Never lift this saw by the arm which holds the blade or damage will occur to your saw.

Separate all parts from packaging materials and check each item with illustration and "Table of Loose Parts." Make certain all items are accounted for before discarding any packaging material.

CAUTION: To avoid injury, if any parts are missing, do not attempt to assemble the Scroll Saw, plug in the power cord, or turn the switch on until the missing parts are obtained and installed correctly.

Table of Loose Parts

Qty.

- | | |
|---|---|
| 1. 16" Scroll Saw (Completely assembled) | 1 |
| 2. Owner's Manual | 1 |
| 3. Parts Bag containing: | 1 |
| 1 Blade, 2 Hex "L" Wrenches, and 1 U-Shaped Bar | |

NOTE: Hardware to mount this scroll saw to a bench or leg set is NOT supplied. See mounting instructions for recommended hardware size.

COMBINATION SQUARE MUST BE TRUE

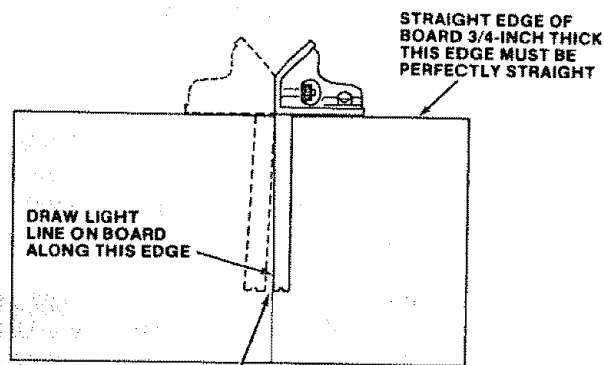

SHOULD BE NO GAP OR OVERLAP HERE WHEN SQUARE IS FLIPPED OVER IN DOTTED POSITION

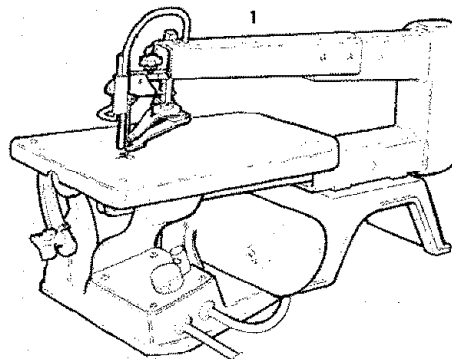

assembly

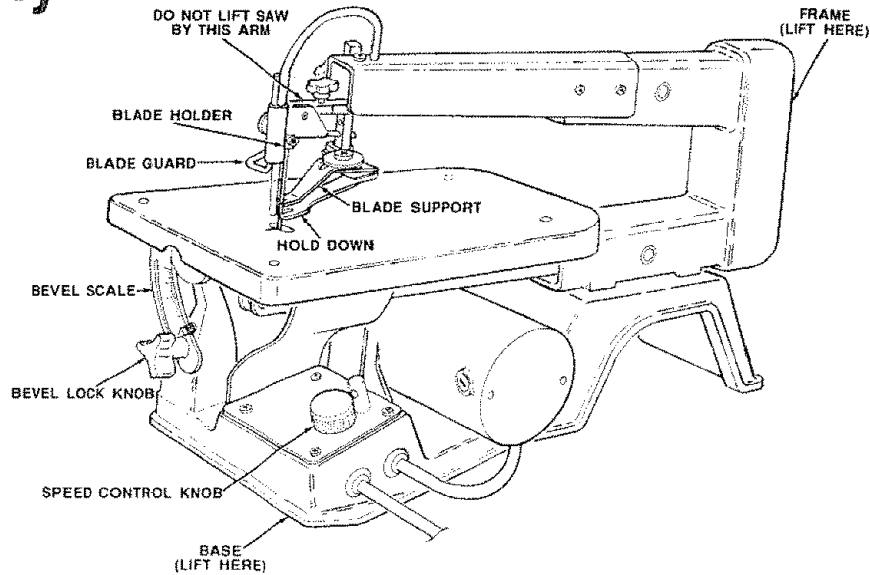

WARNING: FOR YOUR OWN SAFETY, NEVER CONNECT PLUG TO POWER SOURCE OUTLET UNTIL ALL ASSEMBLY STEPS ARE COMPLETE, AND YOU HAVE READ AND UNDERSTAND THE SAFETY AND OPERATIONAL INSTRUCTIONS.

1. Lift the saw by the frame and base and place scroll saw on work bench.
2. Familiarize yourself with the controls and features of this scroll saw indicated in illustration.

SETTING THE TABLE FOR HORIZONTAL OR BEVEL CUTTING

1. The scroll saw work table can be tilted to the left for bevel cutting up to 45 degrees from the 0 degree or horizontal cutting position.

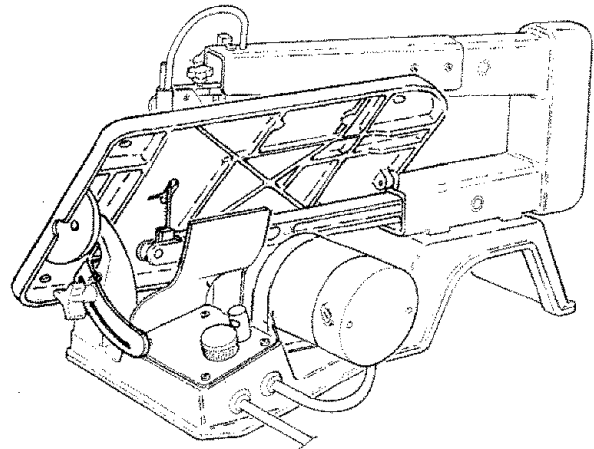

2. A bevel scale is provided under the work table as a convenient reference for setting the approximate table angle for bevel cutting.

When greater precision is required, make trial cuts and adjust the table as necessary for your requirements.

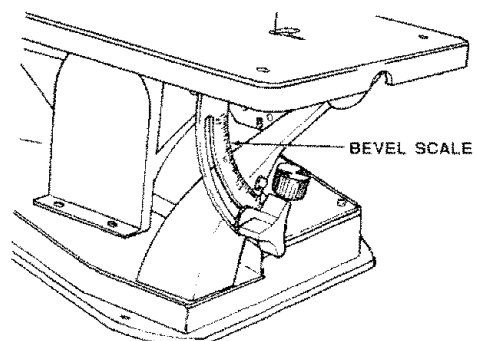

TO ALIGN THE BEVEL INDICATOR

1. Unplug power cord from outlet.
2. Loosen the table bevel lock knob and move the table until it is approximately perpendicular, or at a right angle, to the blade.

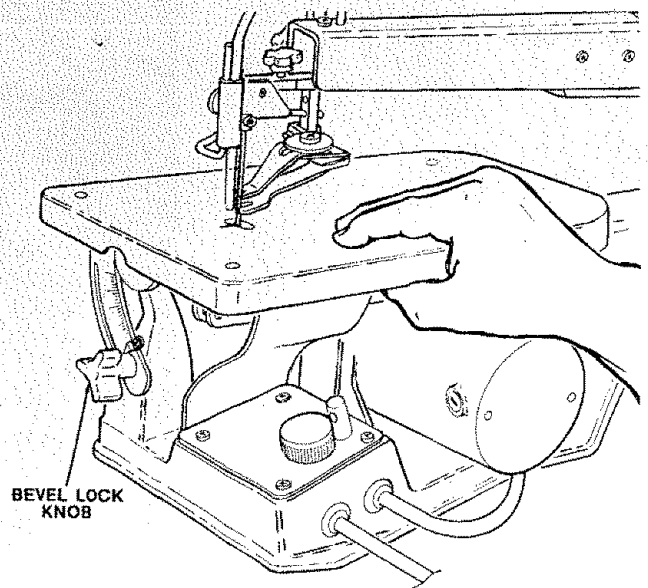

3. Remove blade support and hold down by loosening the screw in the front of the blade support with a hex "L" wrench.

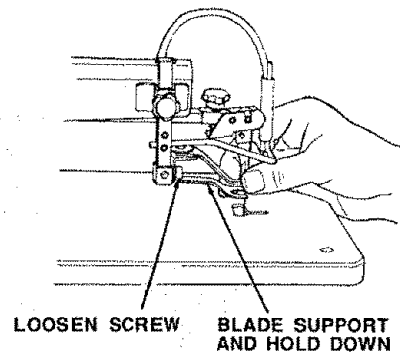

4. Use a small square to set the table at 90 degrees to the blade. If the space between the square and the blade is not uniform, the table must be adjusted.

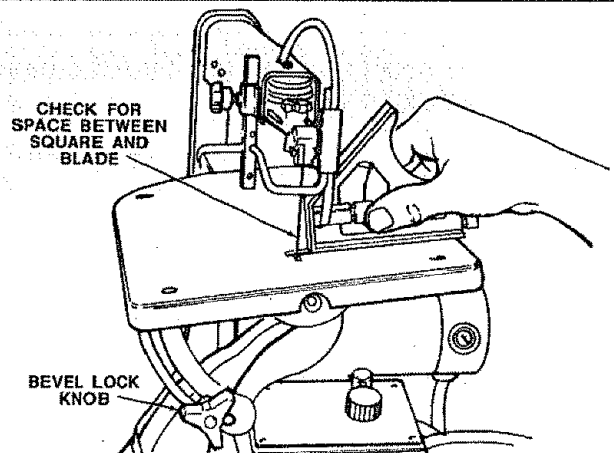

5. When the space between the square and the blade is uniform, tighten the bevel lock knob.

The table should now be approximately 90 degrees to the blade.

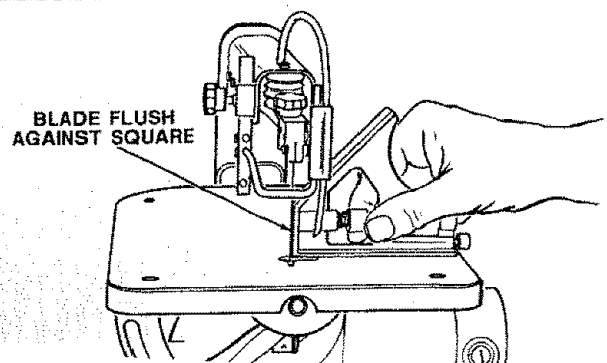

- Loosen the screw holding the bevel scale pointer and adjust pointer to 0 degrees. Tighten screw.

Remember, the bevel scale is a convenient guide, but should not be relied upon for precision.

Reassemble the blade support and hold down.

Make trial cuts in scrap wood to determine if your angle settings are correct. Adjust the table as required.

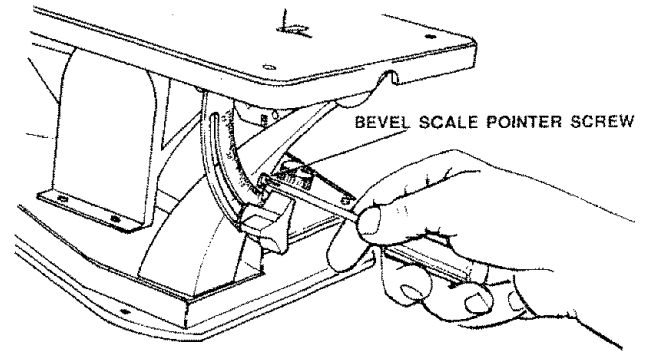

mounting the scroll saw to a bench

Your scroll saw must be bolted securely to stand or work bench. In addition, if there is any tendency for the scroll saw to move during certain operation, bolt your scroll saw stand or workbench to the floor.

- Hardware to mount this saw to a workbench is NOT supplied with the saw. However, we recommend the hardware used be no smaller than the following.

Quantity	Description
4	Hex Head Screws, 1/4-20 x Length as required
4	Flat Washers, 9/32" I.D.
4	Lockwashers, 9/32" I.D.
8	Hex Nuts, 1/4-20

- A soft foam pad to place between your scroll saw and workbench is NOT supplied with the saw. However, we highly recommend the use of such a pad to reduce noise and vibration.

Quantity	Description
1	Soft foam pad such as carpet padding, 24" x 12" x 1/2"

Do NOT overtighten mounting bolts - leave some cushion in the foam pad for absorbing noise and vibration.

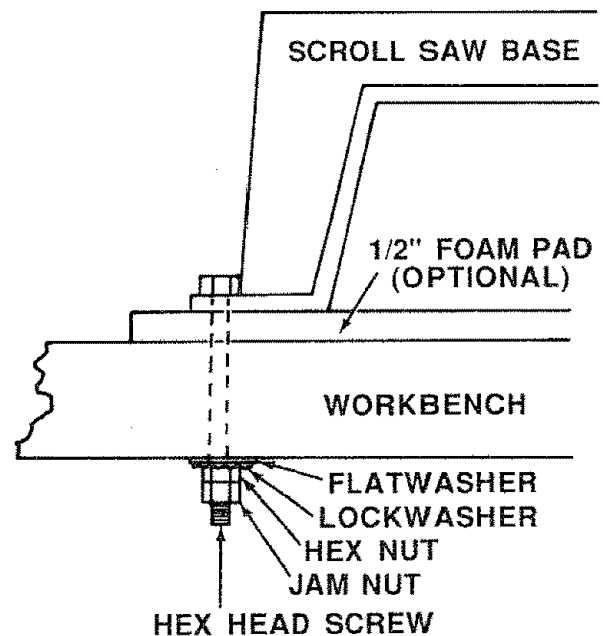

removing and installing blades

1. Unplug power cord from outlet.
2. Loosen tension on blade by turning tension knob counterclockwise about four full turns. Loosen the hex screw of blade holder and push it toward left direction.
3. Support the blade holder by using the "U" shaped bar provided in the parts bag.
4. Slip one side of bar behind the holder while the other side is placed through the hole provided in front of the blade holder.

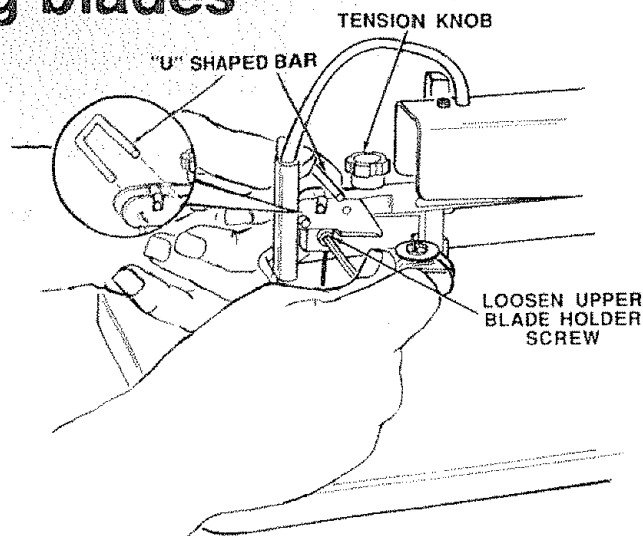

5. Loosen the lower blade holder screw in the same way you loosened the upper blade holder in Steps 2 & 3.

Remove blade by pulling forward on blade and then lifting the blade through the access hole in the table.

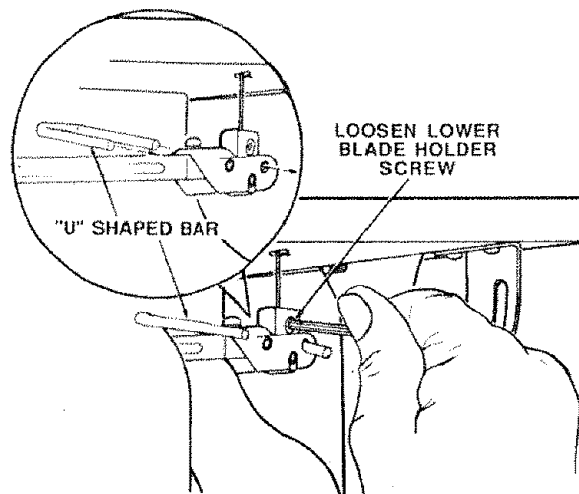

6. Prior to installing blade, make sure the teeth of the blade point down.

Look at the lower blade holder closely, install the new blade through the access hole of the table into the lower blade holder. With hex "L" wrench, fasten the lower blade holder, but not completely tight. Then install the U-shaped bar into the upper blade holder, push the blade into the upper blade holder, and tighten the screw of the upper blade holder. Using the same technique, tighten the screw of the lower blade holder again. Finally, place tension on blade by turning tension knob clockwise after U-shaped bar has been removed. (Approximately four turns.)

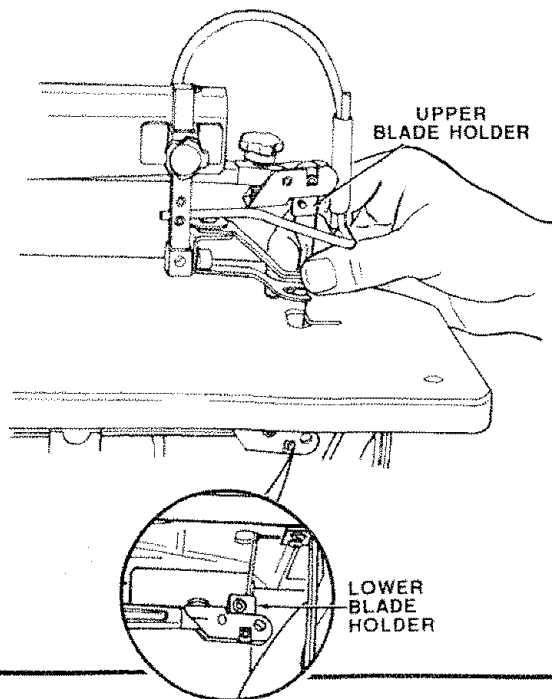

-
7. Adjust the blade support by loosening the screw on the top of blade support with a hex "L" wrench, and tighten the screw after adjusting.

Adjust the blade holder to the table by loosening the lockknob. Make sure the foot is positioned properly against the table. The hex screw (rear of hold down foot) may be loosened to adjust hold down foot. Retighten hex screw after adjustment is complete. Adjust the blade holder to the height of workpiece by adjusting the hold-down foot directly on top of workpiece and tighten lock knob.

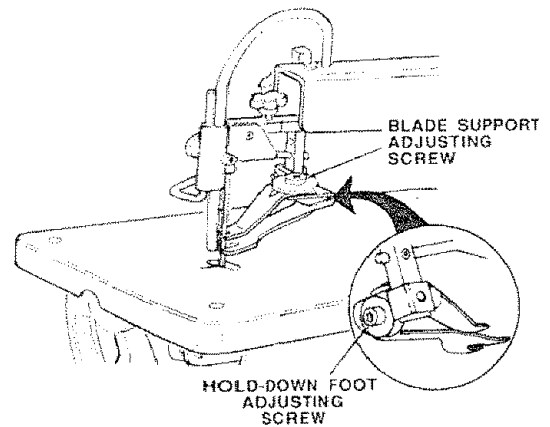
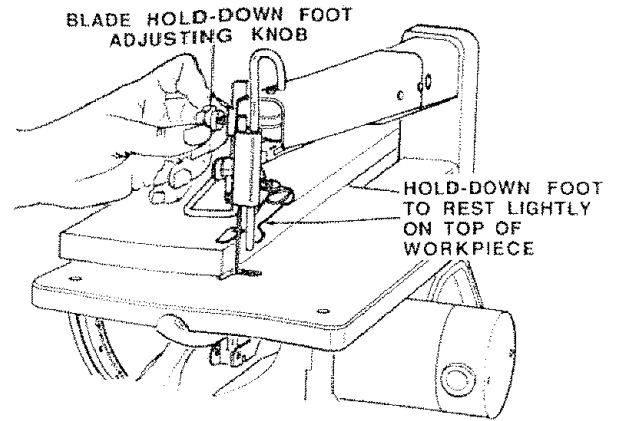

-
8. Before plugging saw in, use your fingers to raise and lower the lower arm so the eccentric mechanism turns at least one cycle to insure the blade is properly installed.

NOTE: Do not remove guard

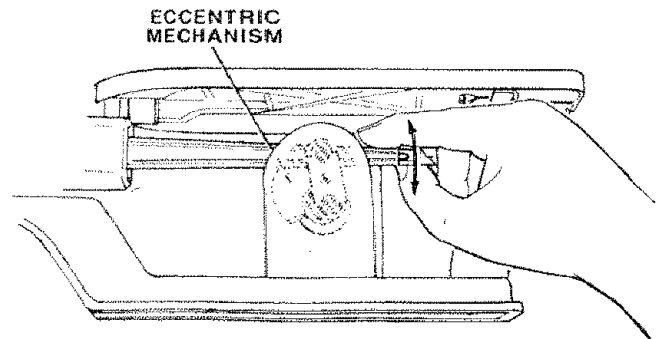

getting to know your scroll saw

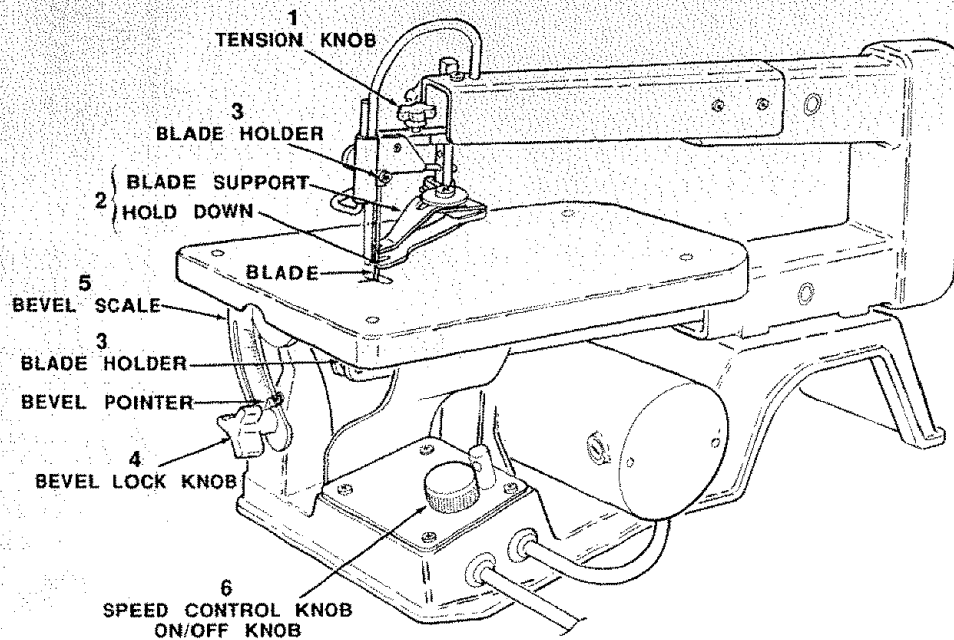

1. TENSION KNOB - Tightening the knob (clockwise) will increase the tension on the blade. Loosening it (counterclockwise) will decrease the tension.
2. HOLD DOWN & BLADE SUPPORT - Provides added control of workpiece and protection for operator and supports blade.
3. BLADE HOLDERS - Retain and position the blade.
4. BEVEL LOCK KNOB - Loosening knob allows blade and housing assembly to tilt up to 45° left for bevel cuts.



5. BEVEL SCALE - Shows degree blade is tilted for bevel cutting.
6. SPEED CONTROL / ON - OFF KNOB - For speed control setting, refer to the "Choice of Blade and Speed" table. The On-Off Knob has a locking feature. THIS FEATURE IS INTENDED TO HELP PREVENT UNAUTHORIZED USE BY CHILDREN AND OTHERS.

ON - OFF KNOB

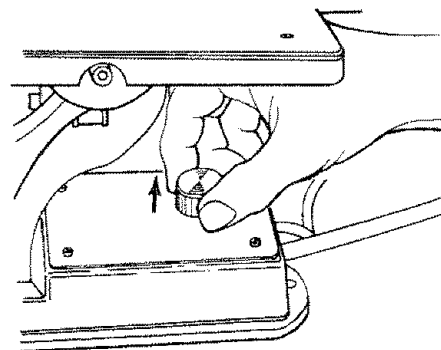
1. To turn machine ON, place fingers on Speed Control Knob and pull up.



2. To turn machine OFF, control knob is pushed down. **NEVER LEAVE THE MACHINE UNATTENDED UNTIL IT HAS COME TO A COMPLETE STOP.**

The variable speed control may be adjusted to the approximate speeds identified on the control panel. Suggested speeds are identified below. Turn the control knob clockwise () to increase strokes per minute and counterclockwise () to reduce the strokes per minute.

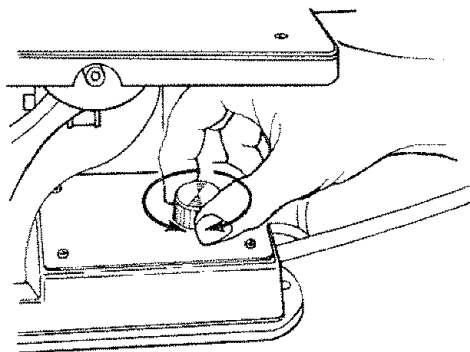
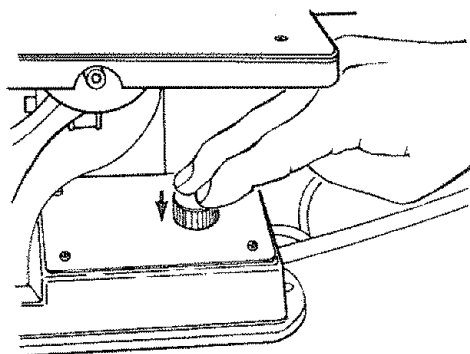

3. To lock knob in OFF position, install a padlock through the post above the knob as illustrated, and lock the padlock. (Padlock is not supplied with the saw.)

WARNING: FOR YOUR OWN SAFETY, ALWAYS PUSH THE KNOB "OFF" WHEN MACHINE IS NOT IN USE . . . ALSO . . . IN THE EVENT OF A POWER FAILURE (ALL OF YOUR LIGHTS GO OUT) PUSH KNOB OFF . . . "LOCKOUT" YOUR KNOB WITH A PADLOCK AS SHOWN. THIS WILL PREVENT THE MACHINE FROM STARTING UP AGAIN WHEN THE POWER COMES BACK ON.

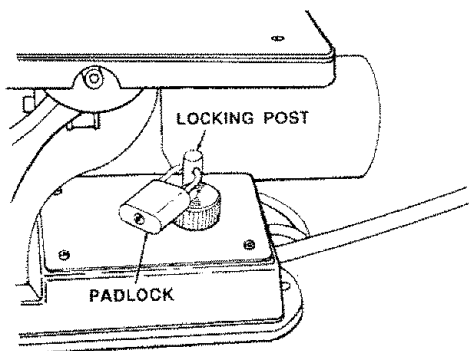

CHOICE OF BLADE AND SPEED

The scroll saw accepts a wide variety of blade widths and thicknesses. The blade width and thickness and the number of teeth per inch are determined by the type of

material and the size of the radius being cut. See the following chart.

Teeth/Inch	Width	Thickness	Speed (Strokes/Min.)	Material Cut
10	.110"	.020"	C (1200 - 1500)	Popular sizes for cutting hard and soft woods 3/16" up to 2". Also plastics, paper, felt, bone, etc.
15	.110"	.020"	B (600 - 1200)	Wood, plastic, extremely thin cuts on materials 3/32" to 1/2" thick.
18	.095"	.010"	A (500 - 600)	For tight radius work in thin materials 3/32" to 1/8" wood veneer, wood, bone, fiber, ivory, plastic, etc.

As a general rule, always select the narrowest blades recommended for intricate curve cutting and widest blades for straight and large curve cutting operation.

operation of your scroll saw

PLEASE, read and understand the following items about your scroll saw before attempting to use the saw.

1. The saw does not cut wood by itself. You allow the saw to cut wood by guiding the wood into the blade as it moves.
2. The blade teeth cut wood ONLY on the down stroke.
3. You must guide the wood into the blade slowly because the teeth of the blade are very small and they can only remove wood when they are on the down stroke.
4. There is a learning curve for each person who wants to use this saw. During that period of time, it is expected that some blades will break until you learn how to use the saw and receive the greatest benefit from the blades.
5. Best results are achieved when cutting wood less than one inch thick.
6. When cutting wood thicker than one inch, the user must guide the wood very, very slowly into the blade and take extra care not to bend or twist the blade while cutting in order to maximize blade life.
7. Teeth on scroll saw blades wear out and as such must be replaced frequently for best cutting results. Scroll saw blades generally stay sharp for 1/2 hour to 2 hours of cutting.
8. To get accurate cuts, be prepared to compensate for the blades' tendency to follow the wood grain as you are cutting.
9. This scroll saw is intended to cut wood or material similar to wood only.
10. When choosing a blade to use with your scroll saw, consider the following carefully.
 - Very fine, narrow blades should be used to scroll cut in thin wood 1/4" thick or less.
 - To cut wood over 1/4" thick, use wider blades.
 - Most blade packages state the size or thickness of wood which that blade is intended to cut, and the radius, size of curve, which can be cut with that blade.
 - Wider blades can't cut curves as tight or small as thinner blades.
 - Narrower blades work well only on thinner wood material.
11. This saw uses 5" long plain end type blades only. See your Sears Catalog or Retail Store for accessory blades.
12. Blades wear faster when cutting plywood, which is very abrasive; when sawing wood which is thicker than 3/4" blade stroke; and when sawing hardwood, or when side pressure is placed on the blade.

MAKING INTERIOR SCROLL CUTS

1. One of the features of this saw is that it can be used to make scroll cuts on the interior of a board without breaking or cutting into the outline or perimeter of the board.

WARNING: TO AVOID INJURY FROM ACCIDENTAL STARTING, ALWAYS PUSH CONTROL KNOB "OFF" AND REMOVE PLUG FROM POWER SOURCE OUTLET BEFORE REMOVING OR REPLACING THE BLADE.

2. To make interior cuts in a board, remove the scroll saw blade as explained in the Assembly Section.
3. Drill a 1/4" hole in the board you will use to make interior cuts.
4. Place the board on the saw table with the hole in the board over the access hole in the table.

1/4" HOLE IN
WORKPIECE
CENTERED OVER
HOLE IN TABLE

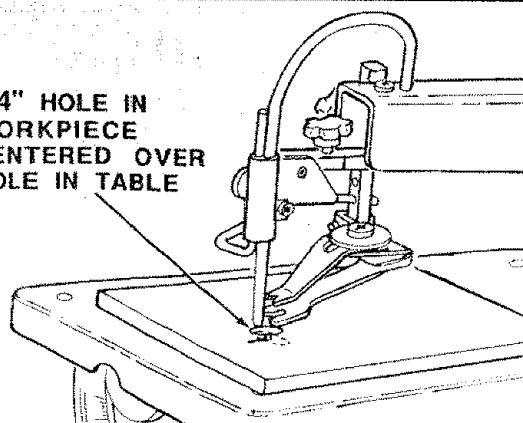

5. Install blade through hole in board and adjust blade tension.
6. When finished making the interior scroll cuts, simply remove the blade from the blade holders, as described in the Assembly Section, and remove the board from the table.

MOUNTING AN AUXILIARY WORK TABLE

1. Four holes are provided in the work table so you can easily attach an auxiliary work surface to the saw if your needs require.
2. Mounting an auxiliary table can allow you to build a larger support area to suit your project, and could render a smoother work surface, as your needs require and an auxiliary surface can give you more support close to the blade for special cutting needs like very small or detailed projects.

WARNING: TO AVOID TOOL TIPPING OR SUPPORT FAILURE, AUXILIARY WORK SURFACE SHOULD NOT EXCEED 24" X 12" X 1/4" AND SAW MUST BE FASTENED TO A WORKBENCH.

At least a 1/4" hole will be needed in the auxiliary surface to insert blades.

DRILL the hole for the blade first. Then MARK location of other holes.

HARDWARE (not supplied) - recommended to mount auxiliary surface to saw worktable.

Quantity	Description
4	Flat Head Screws #8-32 x 1
4	Flat Washers #8
4	Lockwashers #8
4	Hex Nuts #8-32

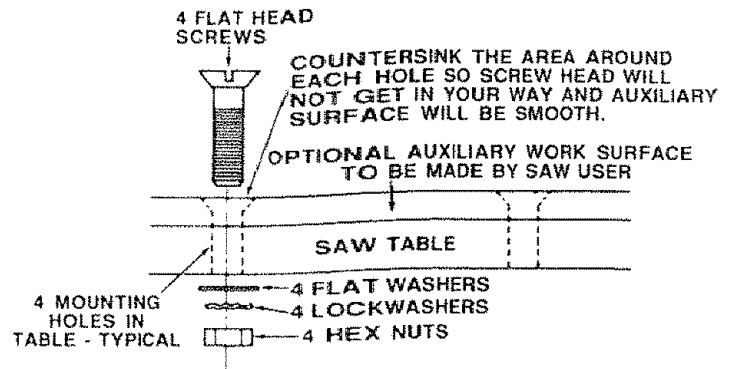

maintenance

WARNING: FOR YOUR OWN SAFETY, PUSH CONTROL KNOB "OFF" AND REMOVE PLUG FROM POWER SOURCE OUTLET BEFORE MAINTAINING OR LUBRICATING YOUR SAW.

GENERAL

An occasional coat of paste wax on the work table will allow the wood being cut to glide smoothly across the work surface.

MOTOR

If the power cord is worn, cut or damaged in any way, have it replaced immediately.

Do not attempt to oil the motor bearings or service the motor internal parts.

ARM BEARINGS

Lubricate the arm bearings after 10 hours of use. Re-oil after every 50 hours of use or whenever there is a squeak coming from the bearings.

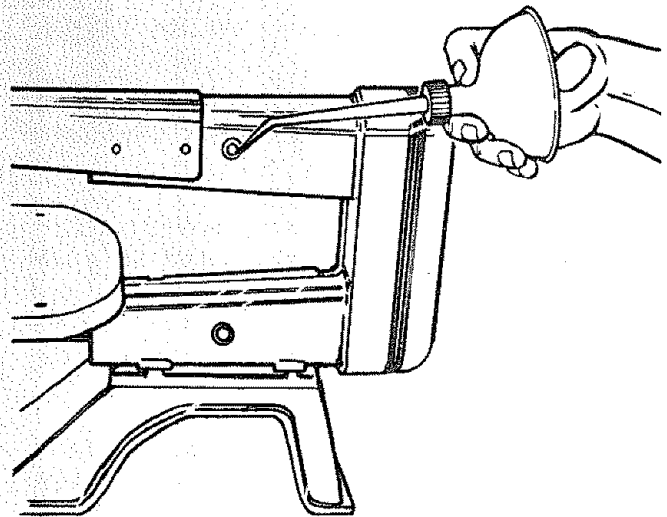

METHOD OF OILING BEARINGS

1. Turn saw on its side.
2. Squirt a generous amount of SAE 20 oil around the shaft end and bronze bearing.
3. Let the oil soak in overnight in this position.
4. Next day repeat the above procedure for the opposite side of the saw.

Sears recommends the following accessories

Item	Sears Number
Blades	See catalog for 5" long, plain end type blades
	Medium radius cuts in wood up to 1-1/2"
	Fine radius cuts in wood up to 1/4" thick

Sears may recommend other accessories not listed in the manual. See your nearest Sears store or Catalog department for other accessories.

Do not use any accessory unless you have received and read complete instructions for its use.

troubleshooting

WARNING: FOR YOUR OWN SAFETY, PUSH CONTROL KNOB "OFF" AND REMOVE PLUG FROM POWER SOURCE OUTLET BEFORE TROUBLESHOOTING YOUR SCROLL SAW.

PROBLEM	PROBABLE CAUSE	REMEDY SUGGESTED
Breaking blades.	<ol style="list-style-type: none"> 1. Wrong tension. 2. Over working blade. 3. Wrong blade application. 4. Twisting blade in wood. 	<ol style="list-style-type: none"> 1. Adjust blade tension. 2. Reduce feed rate. 3. Use narrow blades for cutting thin wood, wide blades for thicker wood. 4. Avoid side pressure on blade.
Motor will not run.	<ol style="list-style-type: none"> 1. Defective cord or plug. 2. Defective motor or control board. 	<ol style="list-style-type: none"> 1. Replace defective parts before using saw again. 2. Consult Sears Service. Any attempt to repair this control board or motor may create a HAZARD unless repair is done by a qualified service technician. Repair service is available at your nearest Sears Store.
Vibration NOTE: There will always be some vibration present when the saw is running because of the reciprocating blade and arms.	<ol style="list-style-type: none"> 1. Improper mounting of saw. 2. Unsuitable mounting surface. 3. Loose table. 4. Loose motor mounting. 	<ol style="list-style-type: none"> 1. See mounting instructions in this manual for proper mounting technique. 2. The heavier your work bench is, the less vibration will occur. A plywood workbench will not be as good a work surface as the same size solid lumber. Use common sense in choosing a mounting surface. 3. Tighten table lock knob. 4. Tighten motor mounting screws.

wiring diagram

WARNING: TO AVOID ELECTOCUTION OR FIRE, REPAIR ELECTRICALS ONLY WITH RECOMMENDED SERVICE PARTS, AND REASSEMBLE EXACTLY AS ORIGINALLY RECEIVED WHEN NEW.

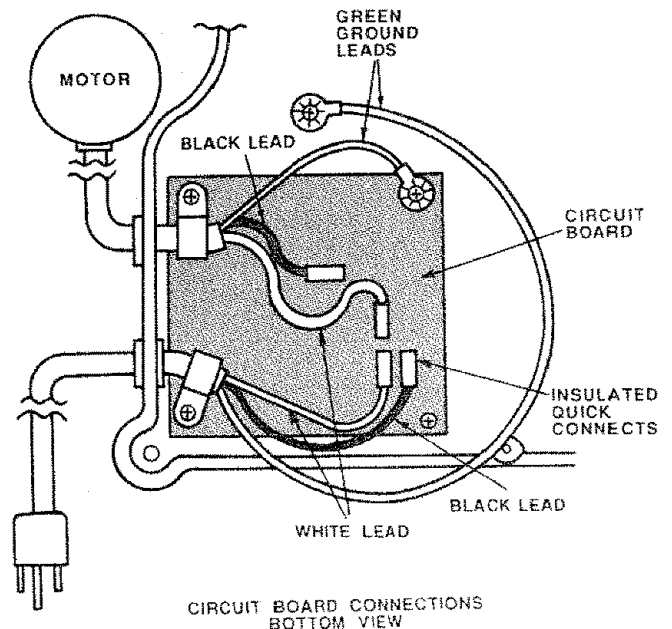

repair parts

PARTS LIST FOR CRAFTSMAN 16" SCROLL SAW
MODEL 113.236180

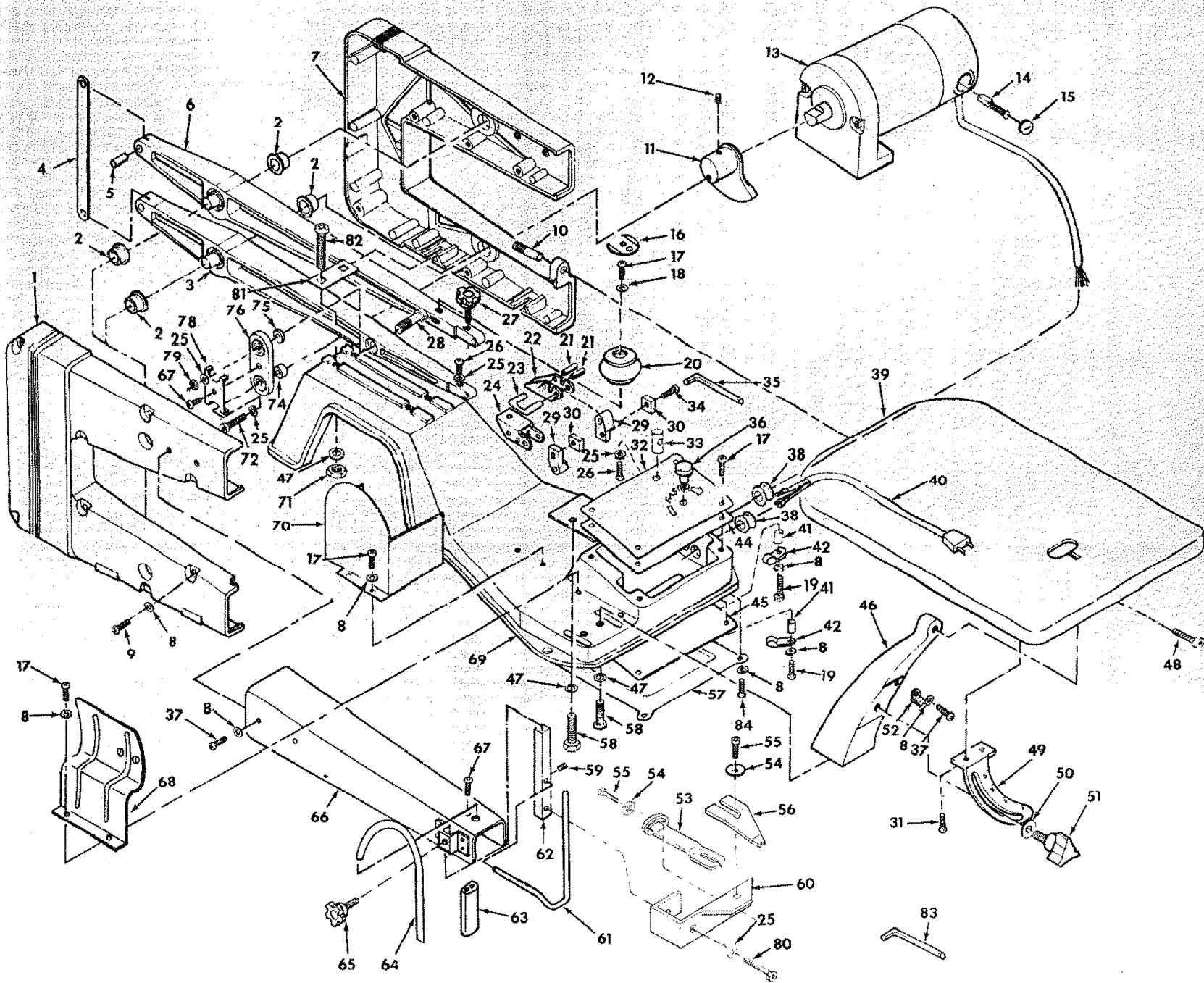

SEARS

*owners
manual*

SERVICE

**MODEL NO.
113.236180**

**SCROLL SAW
Variable Speed**

**HOW TO ORDER
REPAIR PARTS**

**16 INCH SCROLL SAW
VARIABLE SPEED
ELECTRONIC**

Now that you have purchased your Scroll Saw, should a need ever exist for repair parts or service, simply contact any Sears Service Center and most Sears, Roebuck and Co. stores. Be sure to provide all pertinent facts when you call or visit.

The model number of your Scroll Saw will be found attached to the underside of the worktable.

**WHEN ORDERING REPAIR PARTS, ALWAYS
GIVE THE FOLLOWING INFORMATION:**

PART NUMBER PART DESCRIPTION

MODEL NUMBER 113.238180	NAME OF ITEM 16 Inch Scroll Saw Variable Speed Electronic
-----------------------------------	---

All parts listed may be ordered from any Sears Service Center and most Sears stores. If the parts you need are not stocked locally, your order will be electronically transmitted to a Sears Repair Parts Distribution Center for handling.

Sold by SEARS, ROEBUCK AND CO., Chicago, IL. 60684 U.S.A.