

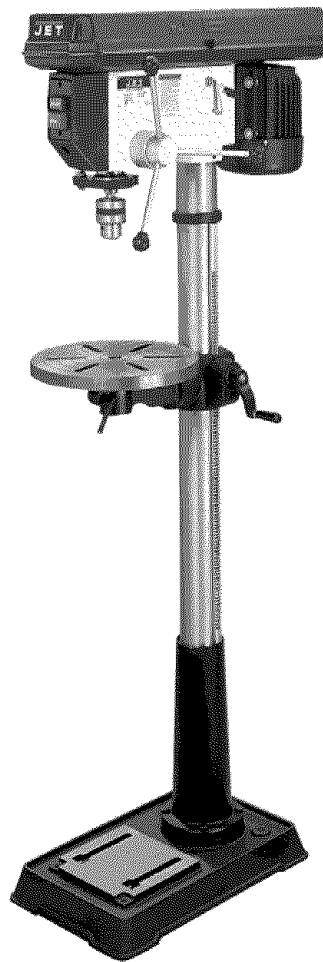

Operating Instructions and Parts Manual

17" Drill Press

Model JDP-17MF



WMH TOOL GROUP

2420 Vantage Drive
Elgin, Illinois 60123
Ph.: 800-274-6848
www.wmhtoolgroup.com

Part No. M-354169
Revision C1 01/06
Copyright © WMH Tool Group

This manual has been prepared for the owner and operators of a JDP-17MF Drill Press. Its purpose, aside from machine operation, is to promote safety through the use of accepted correct operating and maintenance procedures. Completely read the safety and maintenance instructions before operating or servicing the machine. To obtain maximum life and efficiency from your JET Drill Press, and to aid in using the machine safely, read this manual thoroughly and follow instructions carefully.

Warranty and Service

WMH Tool Group warrants every product it sells. If one of our tools needs service or repair, one of our Authorized Service Center located throughout the United States can provide quick service or information.

In most cases, a WMH Tool Group Service Center can assist in authorizing repair work, obtaining parts, or perform routine or major maintenance repair on your JET product.

For the name of an Authorized Service Center in your area, please call 1-800-274-6848, or visit our web site at www.wmhtoolgroup.com

More Information

Remember, WMH Tool Group is consistently adding new products to the line. For complete, up-to-date product information, check with your local WMH Tool Group distributor, or visit our web site at www.wmhtoolgroup.com

WMH Tool Group Warranty

WMH Tool Group makes every effort to assure that its products meet high quality and durability standards and warrants to the original retail consumer/purchaser of our products that each product be free from defects in materials and workmanship as follows: 1 YEAR LIMITED WARRANTY ON ALL PRODUCTS UNLESS SPECIFIED OTHERWISE. This Warranty does not apply to defects due directly or indirectly to misuse, abuse, negligence or accidents, normal wear-and-tear, repair or alterations outside our facilities, or to a lack of maintenance.

WMH TOOL GROUP LIMITS ALL IMPLIED WARRANTIES TO THE PERIOD SPECIFIED ABOVE, BEGINNING FROM THE DATE THE PRODUCT WAS PURCHASED AT RETAIL. EXCEPT AS STATED HEREIN, ANY IMPLIED WARRANTIES OR MERCHANTABILITY AND FITNESS ARE EXCLUDED. SOME STATES DO NOT ALLOW LIMITATIONS ON HOW LONG THE IMPLIED WARRANTY LASTS, SO THE ABOVE LIMITATION MAY NOT APPLY TO YOU. IN NO EVENT SHALL WMH TOOL GROUP BE LIABLE FOR DEATH, INJURIES TO PERSONS OR PROPERTY, OR FOR INCIDENTAL, CONTINGENT, SPECIAL, OR CONSEQUENTIAL DAMAGES ARISING FROM THE USE OF OUR PRODUCTS. SOME STATES DO NOT ALLOW THE EXCLUSION OR LIMITATION OF INCIDENTAL OR CONSEQUENTIAL DAMAGES, SO THE ABOVE LIMITATION OR EXCLUSION MAY NOT APPLY TO YOU.

To take advantage of this warranty, the product or part must be returned for examination, postage prepaid, to an Authorized Service Center designated by our office. Proof of purchase date and an explanation of the complaint must accompany the merchandise. If our inspection discloses a defect, we will either repair or replace the product at our discretion, or refund the purchase price if we cannot readily and quickly provide a repair or replacement. We will return the repaired product or replacement at WMH Tool Group's expense, but if it is determined there is no defect, or that the defect resulted from causes not within the scope of WMH Tool Group's warranty, then the user must bear the cost of storing and returning the product. This warranty gives you specific legal rights; you may also have other rights, which vary from state to state.

WMH Tool Group sells through distributors only. Members of the WMH Tool Group reserve the right to effect at any time, without prior notice, alterations to parts, fittings and accessory equipment, which they may deem necessary for any reason whatsoever.

WARNING

Wear eye protection.

Always keep guards in place and in proper operating condition. Do not operate the machine without the guards for any reason.

Support workpiece adequately at all times during operation; maintain control of work at all times.

This drill press is designed and intended for use by properly trained and experienced personnel only. If you are not familiar with the proper and safe operation of a drill press, do not use until proper training and knowledge has been obtained.

- **REMOVE ADJUSTING KEYS AND WRENCHES.** Form a habit of checking to see that keys and adjusting wrenches are removed from the machine before turning it on.
- **KEEP THE WORK AREA CLEAN.** Cluttered areas and benches invite accidents.
- **DON'T USE IN A DANGEROUS ENVIRONMENT.** Don't use power tools in damp or wet locations, or expose them to rain. Keep work area well lighted.
- **KEEP CHILDREN AWAY.** All visitors should be kept a safe distance from the work area.
- **MAKE THE WORKSHOP KIDPROOF** with padlocks, master switches, or by removing starter keys.
- **DON'T FORCE THE MACHINE.** It will do the job better and safer at the rate for which it was designed.
- **USE THE RIGHT TOOL.** Don't force a machine or attachment to do a job for which it was not designed.
- **USE THE PROPER EXTENSION CORD.** Make sure your extension cord is in good condition. When using an extension cord, be sure to use one heavy enough to carry the current your machine will draw. An undersized cord will cause a drop in the line voltage resulting in power loss and overheating. The table following shows the correct size to use depending on the cord length and nameplate ampere rating. If in doubt, use the next heavier gauge. Remember, the smaller the gauge number, the heavier the cord.

Total Length of Cord in Feet	
0-25	25-50
AWG	
16	14

- **WEAR PROPER APPAREL.** Do not wear loose clothing, gloves, neckties, rings, bracelets, or other jewelry which may get caught in moving parts. Nonslip footwear is recommended. Wear protective hair covering to contain long hair.
- **ALWAYS USE SAFETY GLASSES.** Also use face or dust masks if the cutting operation is dusty. Everyday eyeglasses only have impact resistant lenses; they are not safety glasses.
- **DON'T OVERREACH.** Keep proper footing and balance at all times.
- **MAINTAIN TOOLS WITH CARE.** Keep tools sharp and clean for best and safest performance. Follow instructions for lubricating and changing accessories.
- **ALWAYS DISCONNECT THE MACHINE FROM THE POWER SOURCE BEFORE SERVICING.**
- **REDUCE THE RISK OF UNINTENTIONAL STARTING.** Make sure the switch is in the off position before plugging in.

- **USE RECOMMENDED ACCESSORIES.** The use of accessories and attachments not recommended by JET may cause hazards or risk of injury to persons.
- **NEVER STAND ON A MACHINE.** Serious injury could occur if the machine is tipped.
- **CHECK DAMAGED PARTS.** Before further use of the machine, a guard or other part that is damaged should be carefully checked to determine that it will operate properly and perform its intended function - check for alignment of moving parts, binding of moving parts, breakage of parts, mounting, and any other conditions that may affect its operation. A guard or other part that is damaged should be properly repaired or replaced.
- **NEVER LEAVE THE MACHINE RUNNING UNATTENDED. TURN POWER OFF.** Don't leave the machine until it comes to a complete stop.
- **SOME DUST CREATED** by power sanding, sawing, grinding, drilling and other construction activities contains chemicals known to cause cancer, birth defects or other reproductive harm. Some examples of these chemicals are:
 - Lead from lead based paint
 - crystalline silica from bricks and cement and other masonry products, and
 - arsenic and chromium from chemically-treated lumber.
- Your risk from those exposures varies, depending on how often you do this type of work. To reduce your exposure to these chemicals: work in a well ventilated area, and work with approved safety equipment, such as those dust masks that are specifically designed to filter out microscopic particles
- **DO NOT** operate tool while under the influence of drugs, alcohol or any medication.
- **DO NOT** drill pieces of material that are too small to be safely supported.
- **WHEN** drilling a large workpiece, provide additional support at table height.
- **ADDITIONAL INFORMATION** regarding the safe and proper operation of this product is available from the National Safety Council, 1121 Spring Lake Drive, Itasca, IL 60143-3201, in the Accident Prevention Manual for Industrial Operations and also in the safety Data Sheets provided by the NSC. Please also refer to the American National Standards Institute ANSI 01.1 Safety Requirements for Woodworking Machinery and the U.S. Department of Labor OSHA 1910.213 Regulations.
- **SAVE THESE INSTRUCTIONS** refer to them often and use them to instruct others.

Grounding Instructions

Caution: This tool must be grounded while in use to protect the operator from electric shock.

In the event of a malfunction or breakdown, grounding provides a path of least resistance for electric current to reduce the risk of electric shock. This tool is equipped with an electric cord having an equipment-grounding conductor and a grounding plug. The plug must be plugged into a matching outlet that is properly installed and grounded in accordance with all local codes and ordinances.

Do not modify the plug provided. If it will not fit the outlet, have the proper outlet installed by a qualified electrician.

Improper connection of the equipment-grounding conductor can result in a risk of electric shock. The conductor, with insulation having an outer surface that is green with or without yellow stripes, is the equipment-grounding conductor. If repair or replacement of the electric cord or plug is necessary, do not connect the equipment-grounding conductor to a live terminal.

Check with a qualified electrician or service personnel if the grounding instructions are not completely understood, or if in doubt as to whether the tool is properly grounded. Use only three wire extension cords that have three-prong grounding plugs and three-pole receptacles that accept the tool's plug.

Repair or replace a damaged or worn cord immediately.

115 Volt Operation

As received from the factory, your drill press is ready to run at 115 volt operation. This drill press, when wired for 115 volt, is intended for use on a circuit that has an outlet and a plug that looks like the one illustrated in (A). A temporary adapter, which looks like the adapter as illustrated in (B), may be used to connect this plug to a two-pole receptacle, as shown in (B) if a properly grounded outlet is not available. The temporary adapter should only be used until a properly grounded outlet can be installed by a qualified electrician. **This adapter is not applicable in Canada.** The green colored rigid ear, lug, or tab, extending from the adapter, must be connected to a permanent ground such as a properly grounded outlet box, as shown in (B).

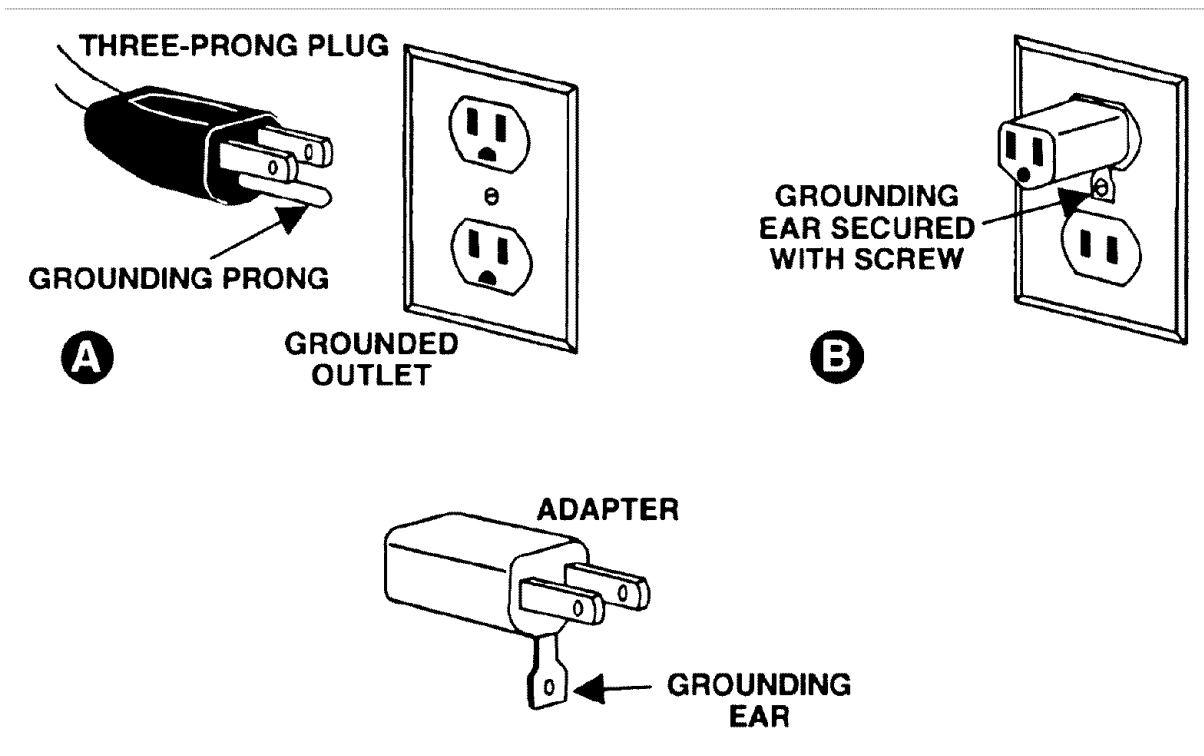

230 Volt Operation

If 230V, single phase operation is desired, the following instructions must be followed:

1. **Disconnect the machine from the power source.**
2. This JET drill press is supplied with four motor leads that are connected for 115V operation, as shown in Figure A. Reconnect these four motor leads for 230V operation, as shown in Figure B.
3. The 115V attachment plug (A), supplied with the drill press, must be replaced with a UL/CSA listed plug suitable for 230V operation (D). Contact your local Authorized JET Service Center or qualified electrician for proper procedures to install the plug. The drill press must comply with all local and national codes after the 230 volt plug is installed.
4. The drill press with a 230 volt plug should only be connected to an outlet having the same configuration (D). No adapter is available or should be used with the 230 volt plug.

Important: In all cases (115 or 230 volts), make certain the receptacle in question is properly grounded. If you are not sure, have a registered electrician check the receptacle.

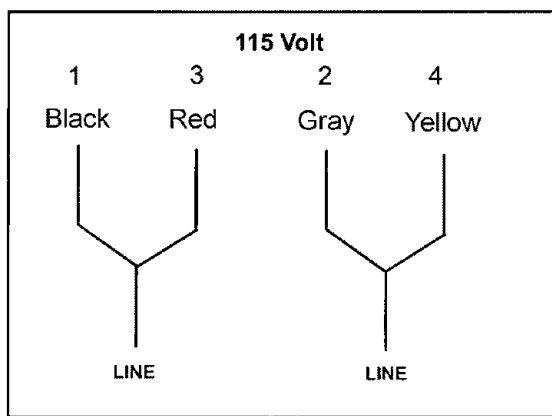

FIGURE A

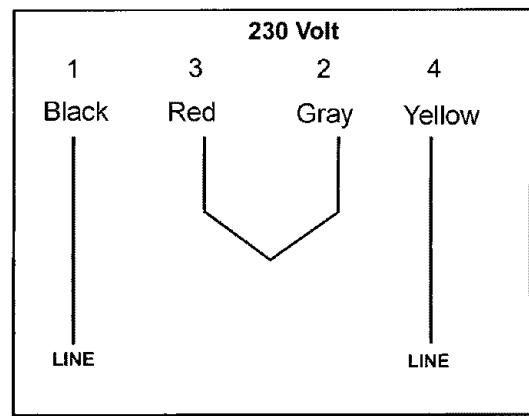
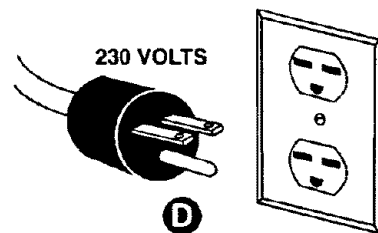
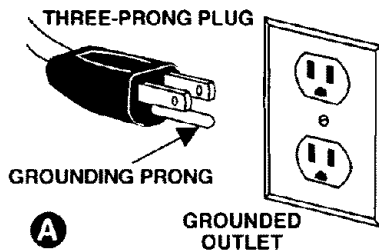

FIGURE B



NOTE: If 230V is needed, a 230V light bulb must be used in the lamp. Or, the lamp circuit may be re-wired in accordance with the diagram on page 21 and a 115V bulb may continue to be used.

On-Off Switch Padlock
Model No. BP-1, Stock No. 709736

To safeguard your machine from unauthorized operation and to avoid accidental starting by young children, the use of a padlock is highly recommended. JET model BP-1 is available from your local authorized JET distributor or by calling WMH Tool Group at 800-274-6848.

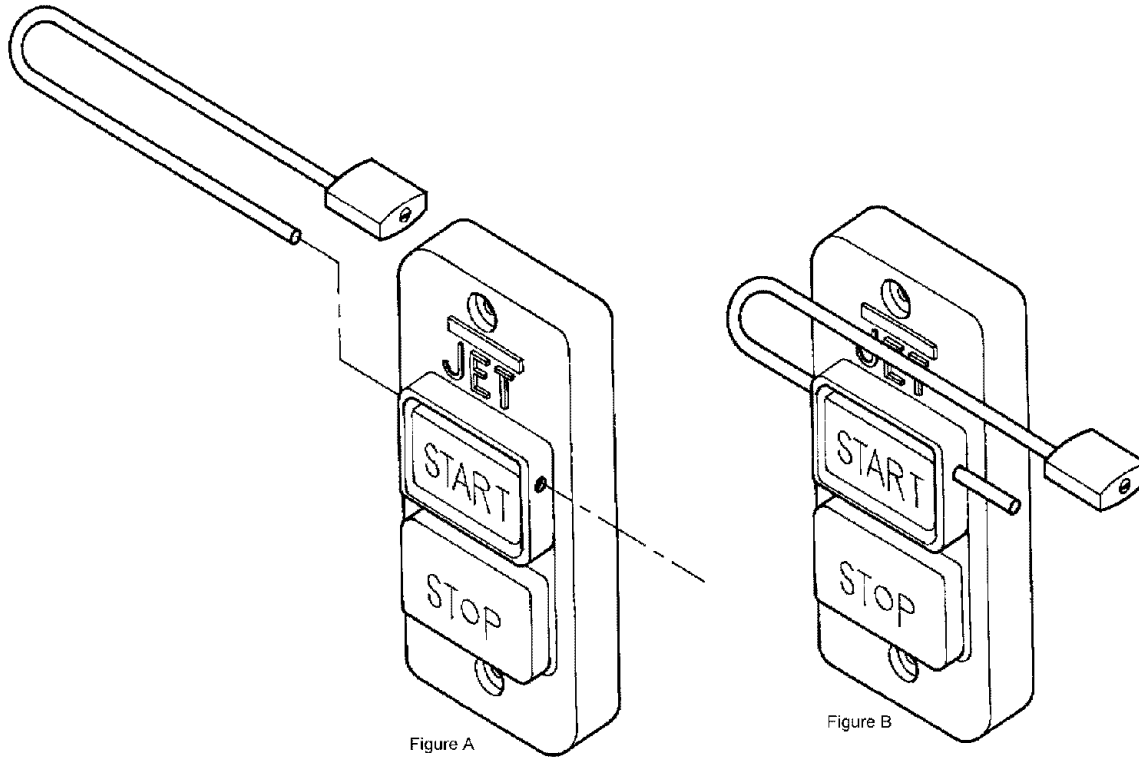

To lock out an on-off switch:

1. Open the padlock. See Fig. A.
2. Insert through holes in the start button. See Fig. B
3. Close the padlock.
4. Place the key in a safe place.

Specifications:

JDP-17MF

Stock Number	354169
Swing.....	16-1/2"
Type	Floor
Drilling Capacity	5/8"
Chuck Size	5/8"
Spindle Travel	4-3/8"
Spindle Distance to Base	49"
Spindle Distance to Table (max.).....	29-1/8"
Table Size Diameter.....	13-3/4"
Table Tilt.....	+ or - 45°
Spindle Taper.....	MT-2
Column Diameter	3-1/8"
Number of Spindle Speeds	16
Range of Spindle Speeds	200-3,630 RPM
Overall Height	66"
Base Size	12-1/2" x 19-5/8"
Motor	3/4HP, 1 Ph
.....	115/230V, prewired 115V
Net Weight (approx.).....	189 lb.
Shipping Weight (approx.)	200 lb.

Table of Contents

Page

Warranty.....	2
Warnings	3-4
Grounding Instructions	5
115V Operation	5
230V Operation	6
On-Off Switch Padlock.....	7
Specifications	8
Table of Contents	8
Contents of Shipping Container	9
Tools Supplied for Assembly	9
Tools Required for Assembly.....	9
Before Assembly	9
Assembly.....	10-11
Removing the Chuck and Arbor.....	11
Adjusting the Depth Stop	12
Changing Spindle Speeds	12
Speed and Pulley Chart.....	13
Return Spring Adjustment.....	14
Table Tilt Adjustment	14
Basic Operation.....	15
Lubrication.....	15
Troubleshooting	16
Part's Breakdown	17
Part's List	18-20
Wiring Diagram	21

The specifications in this manual are given as general information and are not binding. WMH TOOL GROUP reserves the right to effect, at any time and without prior notice, changes or alterations to parts, fittings, and accessory equipment deemed necessary for any reason whatsoever.

Contents of the Shipping Container

1. Head Assembly
1. Table
1. Column and Bracket Assembly
1. Base
1. Owner's Manual
1. Warranty Registration Card
1. Chuck and Chuck Key
3. Downfeed Handle
1. Table Bracket Lock Handle
1. Table Bracket Raising Handle
4. M10 x 40 Hex Cap Bolts
1. Arbor
1. Drift Key

Tools Supplied for Assembly

1. 3mm Hex Wrench
1. 5mm Hex Wrench

Tools Required for Assembly

1. 17mm Box Wrench or a 6"-8" Adjustable Wrench



WARNING!

Read and understand all assembly instructions before attempting assembly! Failure to comply may cause serious injury!

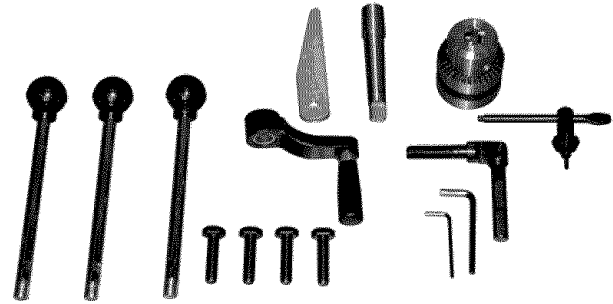

Before Assembly

1. Remove the contents from the shipping container.
2. Compare the contents of the shipping container with the list found above. Report any shortages or damage to your JET distributor.
3. Clean all rust protected surfaces with kerosene or a light solvent. Do not use lacquer thinner, paint thinner, or gasoline. These will damage plastic components and painted surfaces.

Assembly

1. Place the base (A, Fig. 1) on a level floor.
2. With a 17mm wrench attach the column assembly (B, Fig. 1) to the base (A, Fig. 1) with four M10 x 40 hex cap bolts (C, Fig. 1). Tighten firmly.

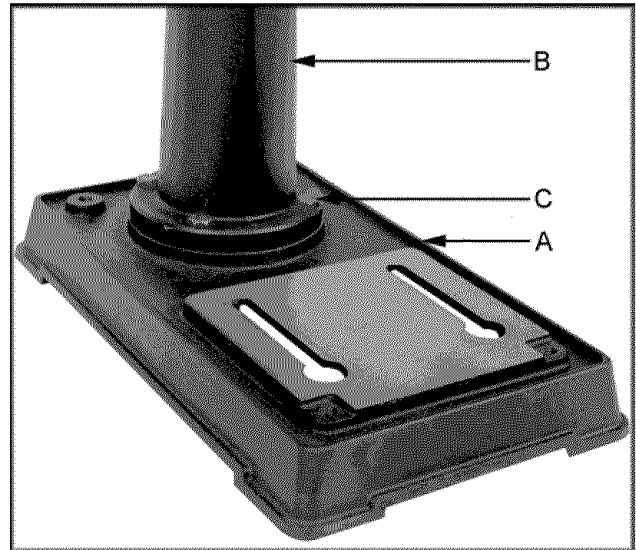

Fig. 1

3. Thread lock handle (D, Fig. 2) into the table bracket (E, Fig. 2).

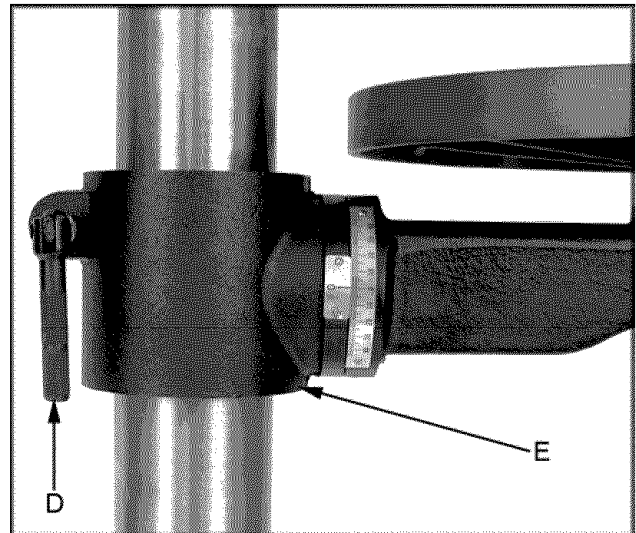

Fig. 2

4. Loosen the set screw (F, Fig. 3) on the raising handle (G, Fig. 3) with a 3mm hex wrench.

5. Slide the handle onto the table bracket shaft.

6. Turn the handle until the set screw is opposite the flat section on the shaft, and tighten the set screw to secure the handle.

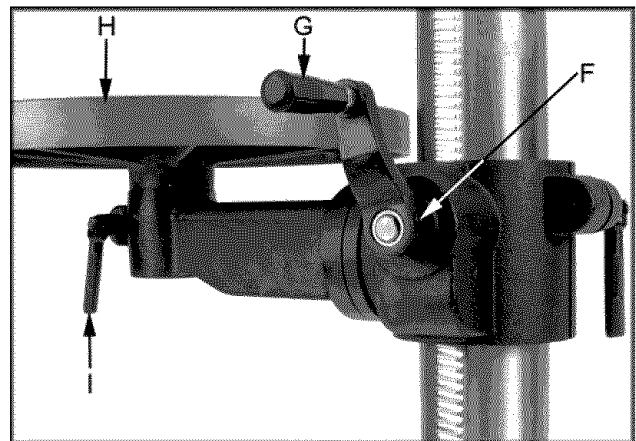

Fig. 3

7. Insert the table (H, Fig. 3) into the table bracket.

8. Tighten the table lock handle (I, Fig. 3).

9. With the aid of a second person, carefully lift the head onto the column top. **Caution: The head assembly is heavy! Use care when lifting onto the column!**
10. Rotate head assembly until sides of the belt cover are parallel with the sides of the base.
11. Tighten two set screws (A, Fig. 4) with a 5mm wrench until they are snug.
12. Install three down feed handles (B, Fig. 4) into the down feed hub (C, Fig. 4).
13. Raise table to approximately seven inches below spindle assembly, and lock the table in place.
14. Place a piece of scrap wood on the table.
15. Thoroughly clean spindle, arbor, and chuck. **Important:** These three pieces must be free of any rust protection, or lubricant. If they are not clean, the arbor and chuck will fail to seat in the spindle.
16. Place arbor into the chuck.
17. Twist the chuck to retract the chuck jaws if they are exposed.
18. Place arbor and chuck assembly into the spindle.
19. Turn the arbor and chuck assembly until the tang on the arbor engages the slot at the end of the spindle.
20. Lower the down feed handle so that the chuck meets the scrap wood. Pressure on the down feed handle once the chuck meets the scrap wood seats the arbor and chuck into the spindle, See Figure. 5.

Removing the Chuck and Arbor

1. **Unplug machine from the power source.**
2. Raise the table until it is about seven inches

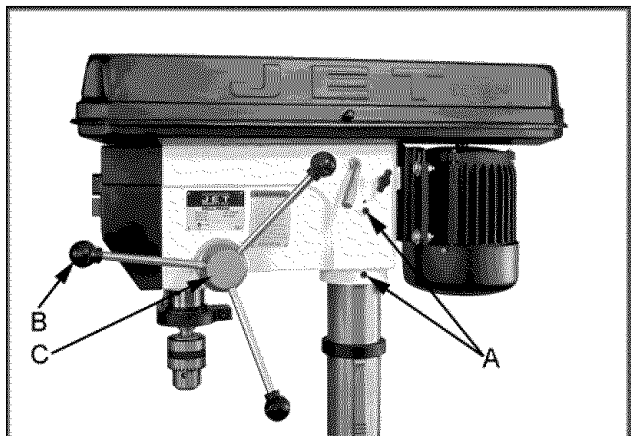

Fig. 4

below the chuck.

3. Place a piece of scrap wood on the table, and lower quill using the down feed handle.
4. Rotate spindle to align the key hole in the spindle with the key hole in the quill.
5. Insert the drift key (D, Fig. 6) into the aligned slots and tap lightly. The chuck and arbor assembly should fall from the spindle.



Fig. 5

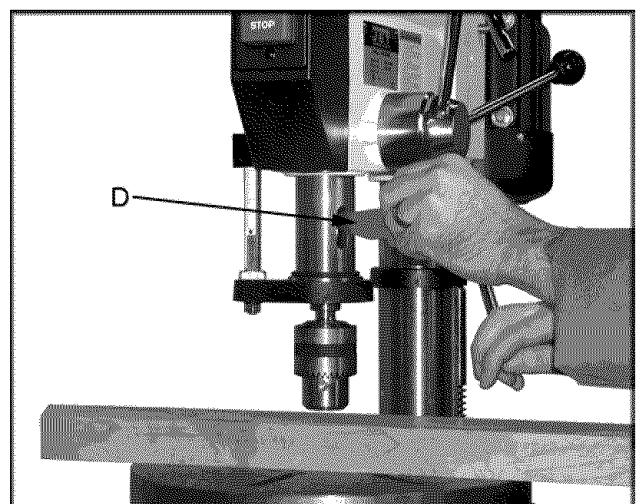

Fig. 6

Adjusting the Depth Stop

To drill multiple holes at the same preset depth, use the depth stop:

1. Use a pencil to mark the depth the bit will drill into the workpiece (A, Fig. 7).
2. With the drill bit in the chuck, lower down feed handle to advance bit to your mark, see Figure 7.
3. With your other hand, advance the lock nuts (B, Fig. 7) on the depth stop rod until they are snug to the seat (C, Fig. 7).
4. The drill bit will now advance to this point.
5. To release, advance the nuts counter-clockwise to the top of the depth stop.

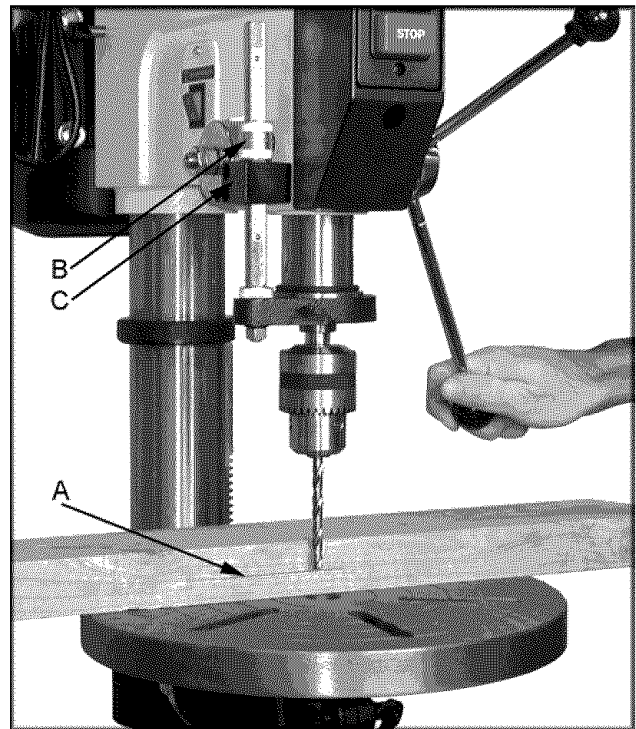

Fig. 7

Changing Spindle Speeds

A spindle speed and belt arrangement chart are found on the inside of the belt cover (D, Fig. 8). Refer to this chart whenever changing speeds.

To change spindle speeds:

1. **Unplug the machine from the power source.**
2. Loosen two bar knobs (E, Fig. 8) found on each side of the head assembly.
3. Rotate the tension adjuster (F, Fig. 8) to bring the motor base as close to the head as possible.
4. Change the belts location according the speed chart and the speed you desire.
5. Rotate the tension adjuster (F, Fig. 8) to tension the belts.
6. Tighten two bar knobs (E, Fig. 8). Belts are properly tensioned when finger and thumb pressure midway between the two pulleys causes approximately $\frac{1}{2}$ " deflection.

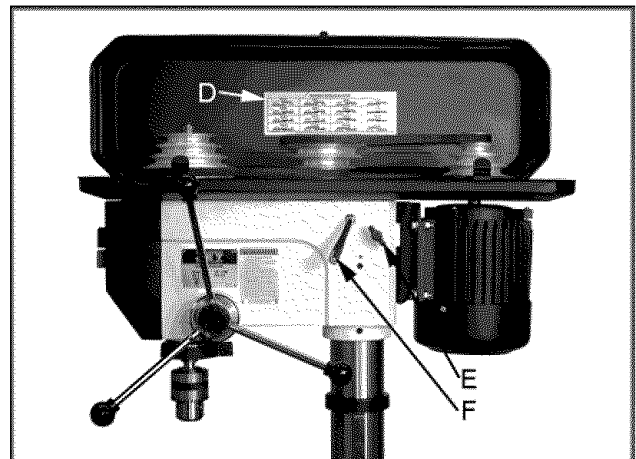









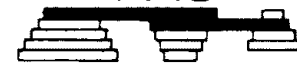

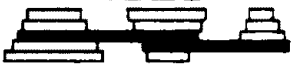





Fig. 8

SPINDLE SPEEDS IN R.P.M.

 200	 290	 350	 430
 500	 580	 640	 720
 800	 870	 1440	 1630
 1820	 2380	 2540	 3630

Speed & Pulley Chart

Return Spring Adjustment

The return spring is adjusted at the factory and should not need further adjustment. If adjustment is deemed necessary:

1. **Unplug the machine from the power source.**
2. Loosen two jam nuts (A, Fig. 9). **Do not remove.**
3. Firmly hold the coil spring cover (B, Fig. 9).
4. Pull out the cover and rotate until the pin (C, Fig. 9) on the return spring plate engages the next notch in the coil spring cover. Turn the cover clockwise to decrease tension and counter-clockwise to increase tension.
5. Tighten two jam nuts (A, Fig. 9). Do not over-tighten. Nuts should not contact the housing when tight. The jam nuts should be tightened against each other.

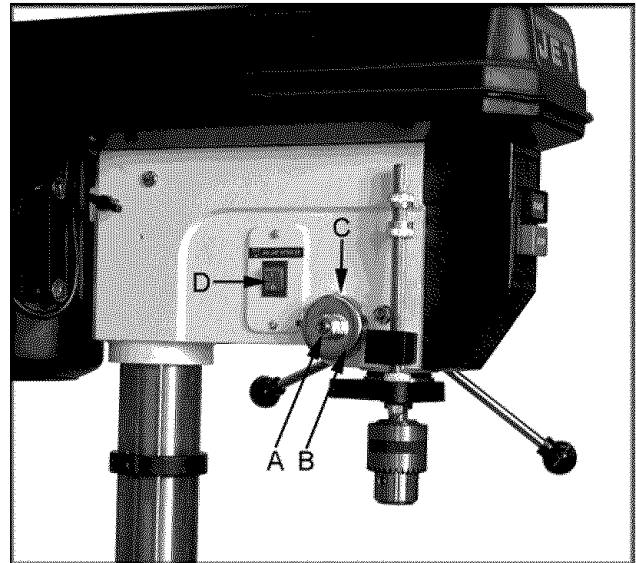

Fig. 9

Work Light

Install a light bulb, no larger than 60 watts into the socket accessed from beneath the head. The light bulb is controlled by the rocker switch (D, Fig. 9).

Table Tilt Adjustment

CAUTION!
Remove the alignment pin first and then loosen the hex cap bolt. Failure to comply may cause the table assembly to separate from the column and fall.

To tilt the table:

1. Turn nut (E, Fig. 10) clockwise to pull out the alignment pin (F, Fig. 10).
2. Loosen hex cap bolt (G, Fig. 10), and tilt the table to the desired angle.
3. Tighten the hex cap bolt (G, Fig. 10).
4. The alignment pin only works at 90° and must be reinserted when the table is returned to 90°.

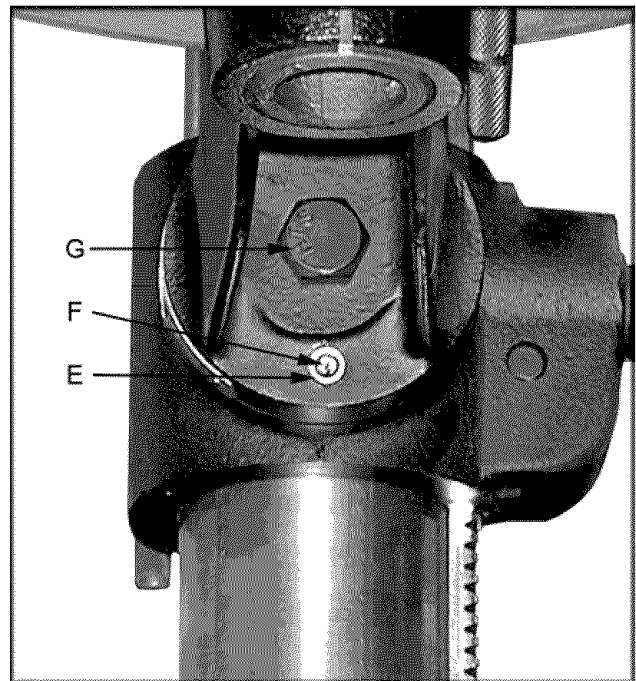

Fig. 10

Basic Operation

- Always use a back-up piece of scrap wood to cover the table. This protects both the table and the drill bit.
- Place material to be drilled in such a way as to come into contact with the left side of the column. This prevents the material from spinning.

WARNING!
If the work piece is not large enough to come into contact with the column, use a clamp or drill press vise that is securely fastened to the table!
Failure to comply may cause serious injury!

- Feed the bit into the material with only enough force to allow the drill bit to work. Feeding too slowly may cause burning of the workpiece. Feeding too quickly may cause the motor to stop and/or the drill bit to break.
- Generally speaking, the smaller the drill bit, the greater the RPM required. Wood requires higher speeds than metal. Metal is usually drilled at slower speeds.
- In dusty environments, frequently blow out any dust that accumulates inside the motor.

Lubrication

Periodically lubricate the gear and the rack, the table elevation mechanism, the splines (grooves) in the spindle, and the teeth of the quill with a #2 tube grease.



Troubleshooting

Trouble	Probable Cause	Remedy
Drill press will not start.	<ol style="list-style-type: none"> 1. Drill press unplugged from wall, or motor. 2. Fuse blown, or circuit breaker tripped. 3. Cord damaged. 4. Starting capacitor bad. 	<ol style="list-style-type: none"> 1. Check all plug connections. 2. Replace fuse, or reset circuit breaker. 3. Replace cord. 4. Replace starting capacitor.
Drill press does not come up to speed.	<ol style="list-style-type: none"> 1. Extension cord too light or too long. 2. Low current. 	<ol style="list-style-type: none"> 1. Replace with adequate size and length cord. 2. Contact a qualified electrician.
Drill Press vibrates excessively.	<ol style="list-style-type: none"> 1. Stand on uneven surface. 2. Bad belt(s). 	<ol style="list-style-type: none"> 1. Adjust stand so that it rests evenly on the floor. 2. Replace belts.
Noisy Operation.	<ol style="list-style-type: none"> 1. Incorrect belt tension. 2. Dry spindle. 3. Loose spindle pulley. 4. Loose motor pulley. 	<ol style="list-style-type: none"> 1. Adjust belt tension. See "Changing Spindle Speeds", page 12. 2. Lubricate spindle. See "Lubrication" page 15. 3. Check tightness of retaining nut on pulley, and tighten if necessary. 4. Tighten set screws in pulleys.
Workpiece Burns.	<ol style="list-style-type: none"> 1. Incorrect Speed. 2. Chips not clearing from hole or bit. 3. Dull drill bit. 4. Feeding too slow. 	<ol style="list-style-type: none"> 1. Change to appropriate speed, see speed and pulley chart, page 13. 2. Retract drill bit frequently to remove chips. 3. Resharpen, or replace drill bit. 4. Increase feed rate.
Drill bit wanders.	<ol style="list-style-type: none"> 1. Bit sharpened incorrectly. 2. Bent drill bit. 3. Bit, or chuck not installed properly. 	<ol style="list-style-type: none"> 1. Resharpen bit correctly. 2. Replace drill bit. 3. Reinstall the chuck, or bit properly.
Wood splinters on the underside.	<ol style="list-style-type: none"> 1. No backing board used. 	<ol style="list-style-type: none"> 1. Place a scrap board underneath the workpiece to prevent splintering.
Drill bit binds in workpiece.	<ol style="list-style-type: none"> 1. Workpiece pinching the bit. 2. Excessive feed rate. 3. Chuck jaws not tight. 4. Improper belt tension. 	<ol style="list-style-type: none"> 1. Support or clamp workpiece. 2. Decrease feed rate. 3. Tighten chuck jaws. 4. Increase belt tension, see page 12.
Excessive drill bit runout, or wobble.	<ol style="list-style-type: none"> 1. Bent drill bit. 2. Worn spindle bearings. 3. Bit, or chuck not properly installed. 	<ol style="list-style-type: none"> 1. Replace drill bit. 2. Replace spindle bearings. 3. Reinstall the bit, or chuck properly.
Quill returns too slow, or too fast.	<ol style="list-style-type: none"> 1. Spring has improper tension. 	<ol style="list-style-type: none"> 1. Adjust "Return Spring Tension," page 14.
Chuck, or arbor do not stay in place.	<ol style="list-style-type: none"> 1. Dirt, grease, etc on arbor, chuck, or spindle. 	<ol style="list-style-type: none"> 1. Clean all mating surfaces thoroughly with a cleaner degreaser.

Parts Breakdown for JDP-17MF

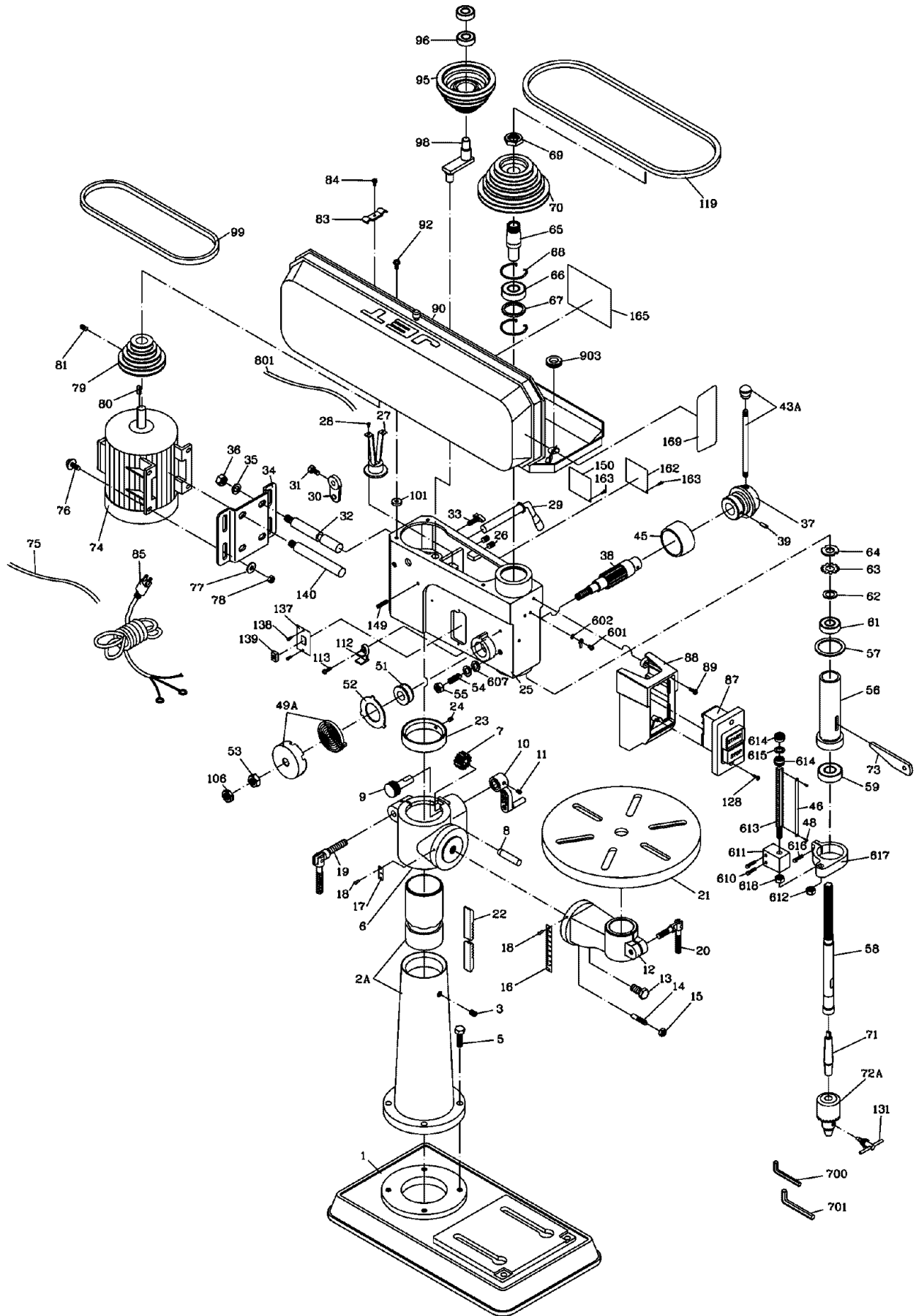

Parts List for JET JDP-17MF Drill Press

Index No.	Part No.	Description	Size	Qty.
1	10600111	Base		1
2A	12909001A1	Column and Holder Assy.		1
3	TS-1525021	Set Screw	M10x12	1
5	TS-1491061	Hex Cap Bolt	M10x40	4
6	10700605A1	Bracket		1
7	10600702	Pinion Gear		1
8	10600802	Gear Shaft		1
9	10600902	Worm Pinion		1
10	10601002	Crank Handle		1
11	TS-1523031	Set Screw	M6x10	1
12	10901203A1	Table Bracket Assy		1
13	TS-0071011	Hex Cap Bolt	5/8"x1-1/2"	1
14	10901402	Locator Pin		1
15	TS-0561011	Hex Nut	1/4"	1
16	10601601	Angle Scale		1
17	10801701	Centering Scale		1
18	2658MZDU36	Drive Screw		4
19	10601901	Column Lock Handle		1
20	10602001	Table Lock Handle		1
21	10702112	Table		1
22	10602205	Rack		1
23	10702307A1	Rack Ring		1
24	TS-1523031	Set Screw	M6x10	1
25	10902515A1	Head		1
26	TS-1525021	Set Screw	M10x12	2
27	10602702	Lamp Socket		1
28	TS-1534042	Pan Head Screw	M6x12	2
29	10902091	Handle Shifter		1
30	10603002A1	Cam		1
31	TS-1490021	Hex Cap Bolt	M8x16	1
32	10703211	Slide Bar (right)		1
33	10903302	Slide Bar Bolt		2
34	10703414	Motor Base	75x125	1
35	TS-0720111	Lock Washer	1/2"	2
36	TS-1540071	Hex Nut	M12	2
37		Handle Body (re:17373839)		1
38	17373839	Feed Shaft Assy (#37,38,39)		1
39		Spring Pin (re: 17373839)		1
43A	10604303A1	Handle Bar Assy		3
45	10604505	Scale Ring		1
46	10904616	Scale		1
48	2658MZDU36	Drive Screw		2
49A	10604902A2	Coil Spring and Cover		1
51	10905116	Spring Seat		1
52	10905203	Plate		1
53	TS-0561052	Hex Nut	1/2"-20UNF	1
54	10605403	Quill Set Screw		1
55	TS-1540071	Hex Nut	M10	1
56	10905612	Quill		1
57	10705703	Rubber Washer		1
58	10905829	Spindle		1
59	BB-6205ZZ	Ball Bearing		1

Index No.	Part No.	Description	Size	Qty.
61	BB-6203Z	Ball Bearing		1
62	10606201	Washer		1
63	10606301	Lock Nut		1
64	10606401	Spindle Nut		1
65	10706508A1	Driving Sleeve		1
66	BB-6205Z	Ball Bearing		2
67	10706705	Collar		1
68	10706802	Retaining Ring		2
69	10606904	Pulley Set Nut		1
70	10607018	Spindle Pulley		1
71	561766	Arbor	MT2xJT3	1
72A	561708	Chuck		1
73	10607303	Wedge		1
74	8907522151	Motor		1
	82061041	Motor Fan (not shown)		1
	89075161	Motor Fan Cover (not shown)		1
	299155BA04	Centrifugal Switch (not shown)		1
	2992A55A14	Capacitor (not shown)		1
75	2808B530C3	Motor Cable		1
76	TS-1490041	Hex Cap Bolt	M8x25	4
77	TS-1550061	Flat Washer	M8	8
78	TS-1540061	Hex Nut	M8	4
79	10607970A1	Motor Pulley		1
80	2571MNC109	Parallel Key		1
81	TS-1524031	Set Screw	M8x12	1
83	12201501	Wire Clip		1
84	TS-1533042	Pan Head Screw	M5x12	1
85	2807BB08C4	Power Cable		1
87	DC1200-44	On-Off Switch		1
88	10908814	Switch Box		1
89	TS-1533052	Pan Head Screw	M5x16	3
90	10909012A1	Pulley Cover Assy		1
92	2641BZDA40	Round Head Screw	M6x16	4
95	10809502	Center Pulley		1
96	BB-6202Z	Ball Bearing		2
98	10609801	Center Pulley Shaft		1
99	VB-A28	V-Belt	A28	1
101	TS-0680021	Flat Washer	1/4"	4
106	TS-0561052	Hex Nut	1/2"-20UNF	1
112	10611201	Chuck Key Holder		1
113	TS-1534042	Pan Head Screw	M6x12	1
119	VB-A29	V-Belt	A29	1
128	2653MBDE15	Tapping Screw		2
131	CK-16	Chuck Key		1
137	10913701	Switch Cover		1
138	TS-1533042	Pan Head Screw	M5x12	2
139	2852D55723	Bulb Switch		1
140	10714001	Motor Bar (left)		1
147	10214704	Protecting Rubber		1
149	2536MBE616	Spring Pin		2
150	10916904	I.D. Label		1
162	10916202	Warning Label		1
163	2658MZDU36	Drive Screw		8
165	10616519	Speed Chart		1

Index No.	Part No.	Description	Size	Qty.
169	11316904	Nameplate		1
601	TS-1533032	Pan Head Machine Screw	M5x10	2
602	2504MZC005	Tooth Washer		2
607	TS-0720101	Lock Washer	7/16"	2
610	TS-1503081	Socket Head Cap Screw	M6x35	2
611	10661102	Seat		1
612	TS-1540081	Hex Nut	M12	1
613	10661301	Scale Bolt		1
614	13005701	Nut		2
615	13005601	Washer		1
616	TS-1504051	Hex Socket Cap Screw	M8x25	1
617	10761701	Set Ring		1
618	10661801	Circular Nut		1
634	TS-1551081	Lock Washer	M12	1
700	TS-152704	Hex Wrench	3MM	1
701	TS-152706	Hex Wrench	5MM	1
801	28065558U4	Bulb Wire		2
903	2801ABRF04	Strain Relief		2

Wiring Diagram

JDP-17MF ELECTRICAL SCHEMATIC - 115V

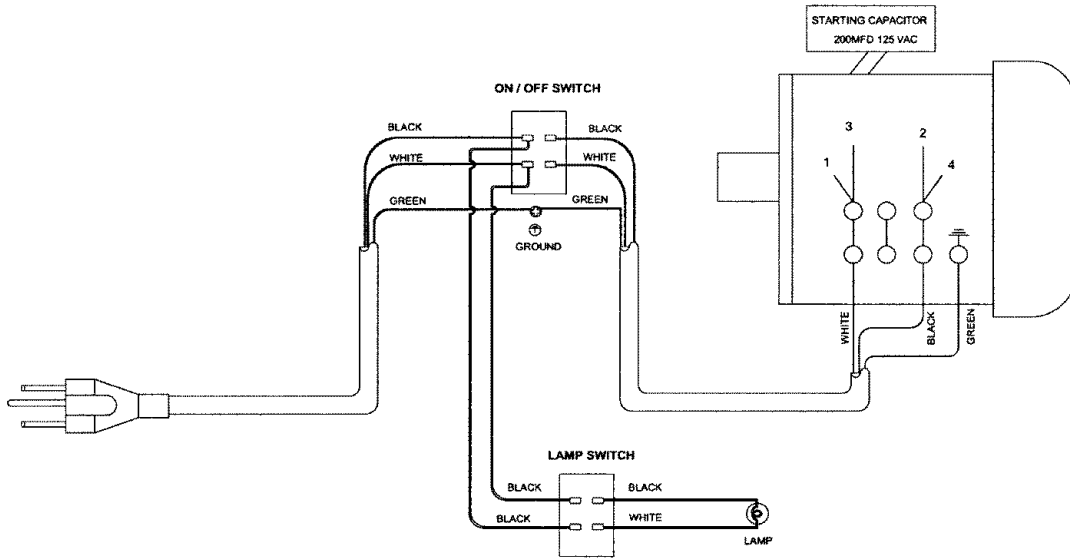

JDP-17MF ELECTRICAL SCHEMATIC - 230V

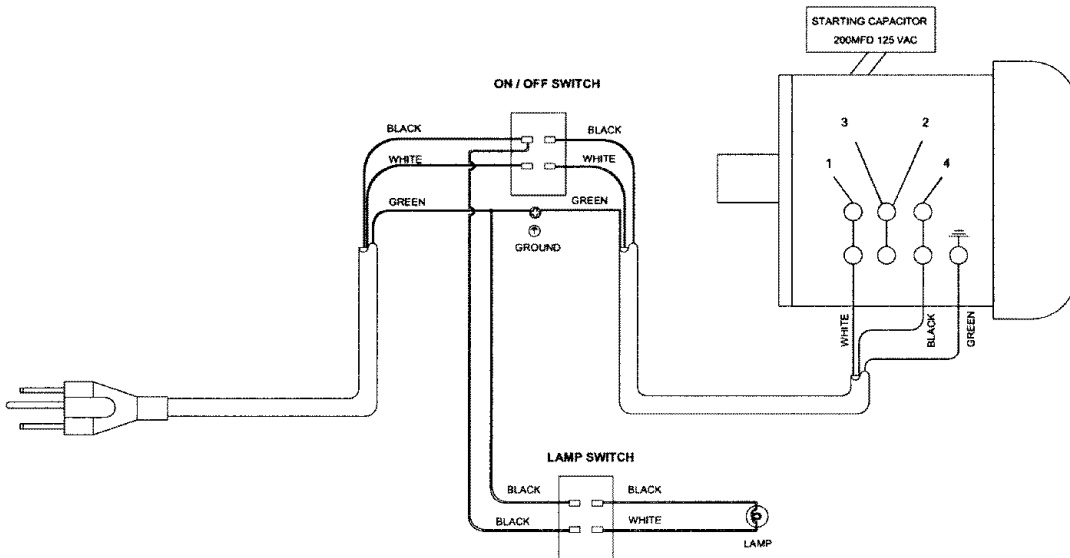



WMH Tool Group
2420 Vantage Drive
Elgin, Illinois 60123
Phone: 800-274-6848
www.wmhtoolgroup.com