

# SEARS

OWNERS  
MANUAL

HOME  
CLEANING  
SYSTEM

MODEL NO.  
175.8690090

**CAUTION:**  
Read Instructions  
and Rules for  
Safe Operation  
Carefully

For Household  
Use Only

Save this  
Manual for  
Future Reference

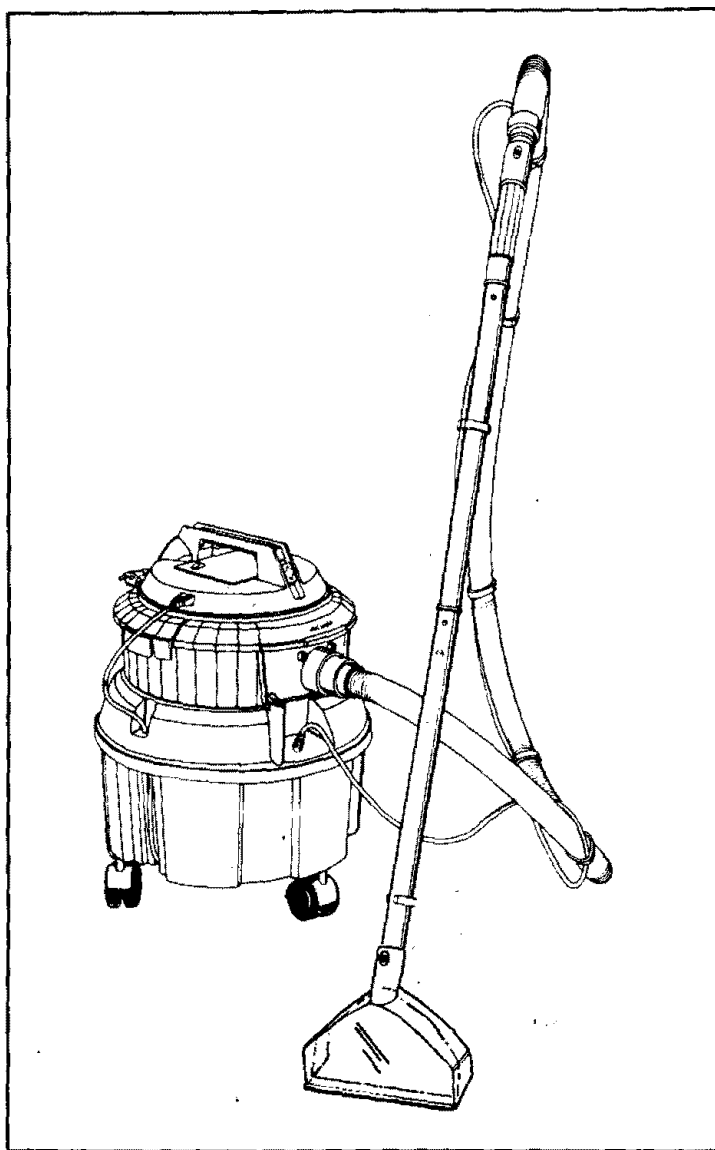

# Kenmore

## HOME CLEANING SYSTEM

- INTRODUCTION
- ASSEMBLY
- OPERATION
- MAINTENANCE
- REPAIR PARTS

SEARS, ROEBUCK AND CO., Dept. D/731 CR-W, Sears Tower, Chicago, IL 60684

## IMPORTANT SAFETY INSTRUCTIONS — Read all instructions before using this cleaner.

When using any electrical appliance, basic precautions should always be followed, including the following:

### WARNING — To reduce the risk of fire, electric shock, or injury:

1. Do not leave cleaner when plugged into electrical outlet. Unplug from outlet when not in use and before servicing.
2. **WARNING: TO AVOID ELECTRIC SHOCK, DO NOT EXPOSE TO RAIN — STORE INDOORS.**
3. **WARNING: DO NOT REMOVE GROUNDING PRONG FROM POWER CORD PLUG.** Connect to a properly grounded outlet ONLY. See Grounding Instructions.

#### GROUNDING INSTRUCTIONS:

This vacuum cleaner must be grounded. If it should malfunction or break down, grounding provides a path of least resistance for electrical current to reduce the risk of electric shock. This vacuum cleaner is equipped with a cord having an equipment-grounding conductor and grounding plug. The plug must be plugged into an appropriate outlet that is properly installed and grounded in accordance with all local codes and ordinances.

**WARNING:** Improper connection of the equipment-grounding conductor can result in a risk of electric shock. Check with a qualified electrician or service person if you are in doubt as to whether the outlet is properly grounded. DO NOT modify the plug provided with the vacuum cleaner — if it will not fit the outlet, have a proper outlet installed by a qualified electrician.

This vacuum cleaner is for use on a nominal 120-volt circuit, and has a grounded plug (see figure A). A temporary adapter (see figure B) may be used to connect this plug to a 2-pole receptacle (see figure B) if a properly grounded outlet is not available. The tempo-

rary adapter should be used only until a properly grounded outlet (see figure A) can be installed by a qualified electrician. The tab for grounding screw (see figure B) extending from the adapter must be connected to a permanent ground such as a properly grounded outlet box cover. Whenever the adapter is in use, it must be held in place by a metal screw (see Figure B).

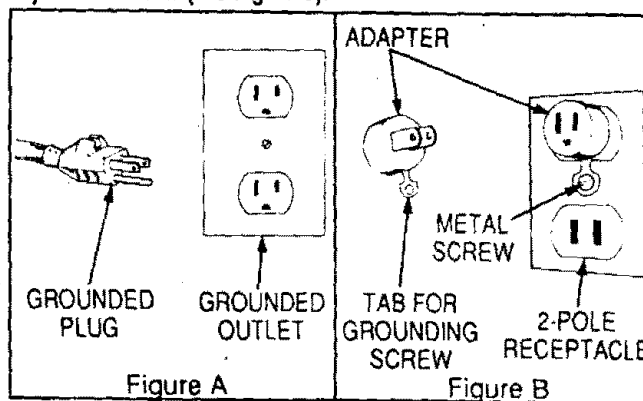

4. **DISCONNECT POWER CORD FROM ELECTRICAL OUTLET** before the recovery tank is emptied, the solution tank is refilled, or the cleaner is serviced in any way.
5. **DO NOT** store this cleaner in an area which may reach freezing temperatures. Should this occur, **DO NOT** operate this cleaner until it has been at room temperature for at least two (2) hours.
6. **DO NOT** use any cleaning solution or chemicals other than those discussed in this manual.
7. For maximum efficiency, empty container frequently and keep inside of hose, wands, nozzle and container clean.
8. **DO NOT** overwet carpet or upholstery. If three or more cleaning strokes are required, let the carpet or upholstery material dry and then repeat cleaning process.
9. Do not allow children to operate cleaner, nor should they play with cleaner as a toy. Close attention is necessary when used around or near children.
10. Use this cleaner **ONLY** for its intended use as described in this manual. Use only the attachments recommended in this manual.
11. Always turn cleaner **OFF** when connecting or disconnecting the Spraymate motorized nozzle.
12. Do not use with damaged cord or plug. If cleaner is not working properly, has been dropped, damaged, left outdoors, or dropped into water, return it to a Sears Service Center.
13. Do not pull or carry by cord, nor use cord as a handle, nor close a door on cord, nor pull cord around sharp edges or corners. Do not run cleaner over cord. Keep away from heated surfaces.
14. Do not unplug from electrical outlet by pulling on the cord. To unplug, grasp the plug, not the cord, and pull.
15. Do not handle plug or cleaner with wet hands.
16. Do not put any objects in ventilation openings. Do not use with any opening blocked; keep openings free of dust, lint, hair, and anything that may reduce air flow.
17. Keep hair, loose clothing, fingers, and all parts of the body away from openings and moving parts.
18. **NEVER** vacuum materials such as hot coals, cigarette butts, matches, etc.
19. When "dry" vacuuming do not use without filter in place.
20. Turn off all controls before unplugging.
21. Use extra care when using on stairs.
22. Do not use to pick up flammable or combustible liquids such as gasoline or use in areas where such liquids may be present.

— SAVE THESE INSTRUCTIONS —

## TABLE OF CONTENTS

Safety Instructions .....	page 2	Additional Uses / Optional Accessories .....	page 8-9
Warranty .....	page 3	Trouble Shooting Chart .....	page 10
Introduction .....	page 3	Exploded Views and Parts Lists .....	page 11-15
Assembly .....	page 4	Ordering Parts .....	page 16
Operation .....	page 5-8		

### **FULL ONE YEAR WARRANTY**

When used for private household purposes, if within one year from the date of purchase, this vacuum cleaner fails due to a defect in material or workmanship, RETURN IT TO THE NEAREST SEARS SERVICE CENTER/DEPARTMENT IN THE UNITED STATES, and Sears will repair it, free of charge.

If this vacuum cleaner is used for commercial or rental purposes, the above warranty coverage applies for only 90 days from the date of purchase.

This warranty gives you specific legal rights, and you may also have other rights, which vary from state to state .  
SEARS, ROEBUCK AND CO., D/731CR-W, SEARS TOWER, CHICAGO, IL 60684

## INTRODUCTION

Your new Kenmore Home Cleaning System is a deluxe high performance cleaner, designed for today's cleaning requirements. With proper care and maintenance, it should provide you with years of service. It is important that you read this manual to fully understand the cleaner's capabilities as well as providing you with the essentials regarding maintenance and safety. A complete list of operating parts and features is shown in figure 1 below.

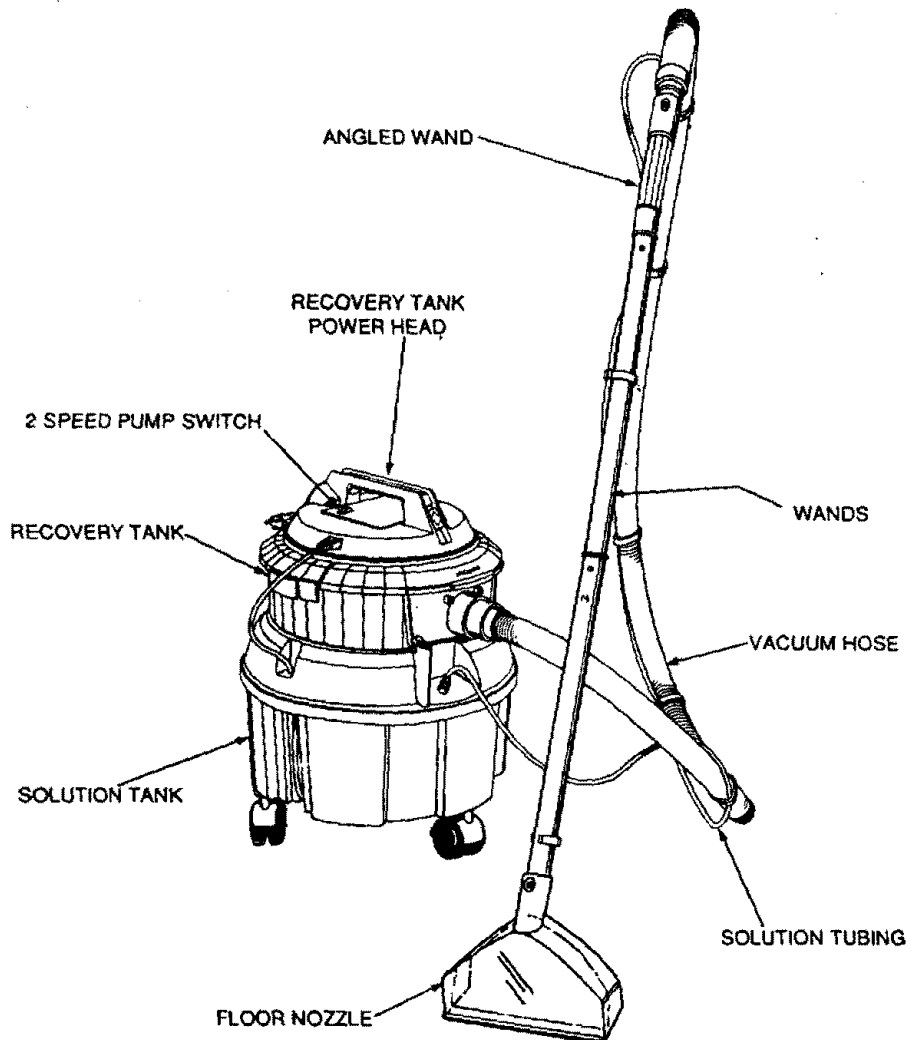

Fig. 1

# ASSEMBLY

## ASSEMBLY OF RECOVERY TANK AND SOLUTION TANK

See Figure 2

1. Place Recovery Tank into Solution Tank (align the word "VACUUM" on Recovery Tank with "VACUUM" on Solution Tank) and secure with Metal Latch.
2. Insert the plug on the Short Cord from the Solution Tank into the Recovery Tank Power Head.

## ASSEMBLY OF HOSE, WANDS, NOZZLE AND SOLUTION TUBING

See Figure 1

1. Assemble the two Straight Wands.
2. Assemble the upper Straight Wand to the Angled Wand of the Hose.
3. Assemble the Floor Nozzle to the lower Straight Wand.  
NOTE: Be sure locking button engages properly when assembling straight wands, angled wand, and floor nozzle.
4. Push the Solution Tube Quick-Disconnect Nut onto Trigger Valve. Twist clockwise to lock. See DETAIL "A" - Figure 3.
5. Snap Solution Tubing into Retaining Clips on the Wands. Tubing may be wrapped around Wands to take up excess slack.
6. Attach the Vacuum Hose to Recovery Tank inlet (Vacuum Inlet).
7. Push Tab to make sure it is in the open position, then insert the Plastic Insert of the Solution Tubing into the Coupling of the Solution Tank. See DETAIL "B" - Figure 3. You should hear a "click" when installed to the proper depth.

NOTE: To remove the Plastic Insert depress the Tab and gently pull on the Plastic Insert. Be careful to pull on the Plastic Insert and not the Tubing as damage may occur.

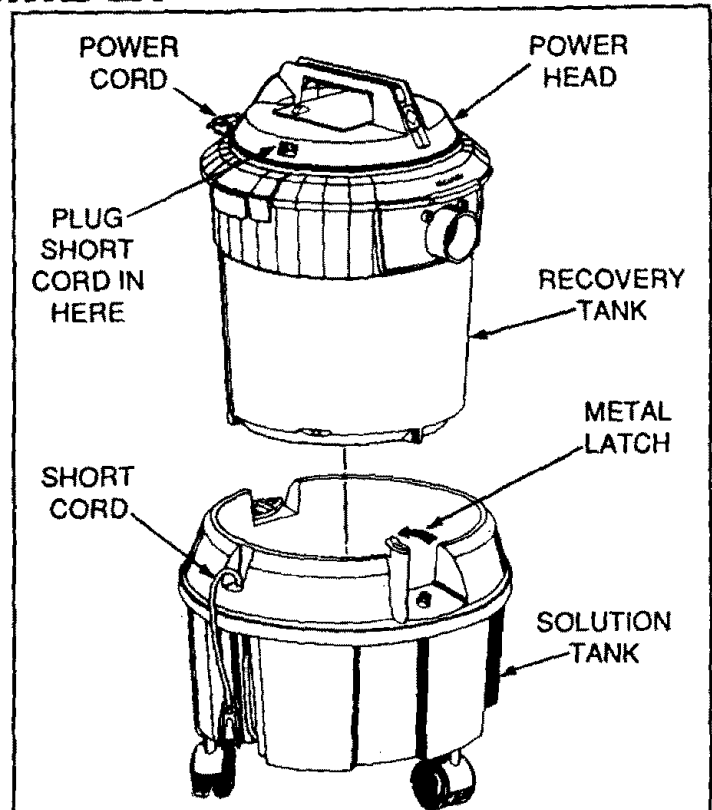

Fig. 2

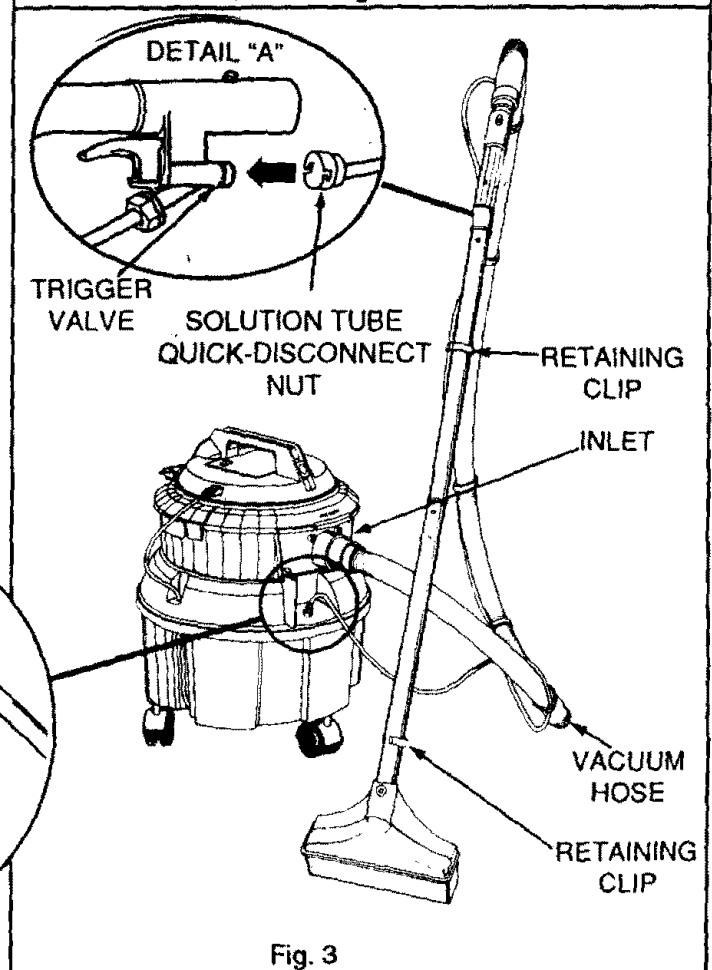
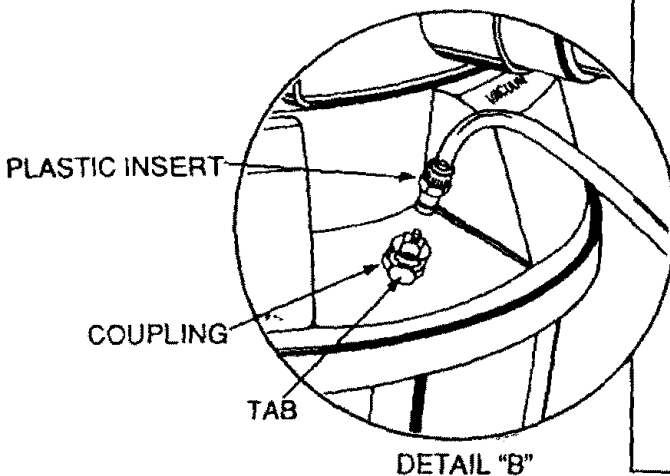

Fig. 3



# OPERATION

## CARPET PREPARATION

For best results prepare carpet for cleaning as follows:

1. Vacuum carpet to remove loose dirt before using Cleaner.
2. To remove stains and ground in dirt present in heavy traffic areas of the carpet, spray or rub Sears Heavy Traffic Pre-Treatment (82833) into carpet before using Cleaner. Follow directions on the bottle.

## FILLING CLEANER WITH WATER AND CLEANING SOLUTION

See Figure 4

1. Open lid of the Filler Opening.
2. Add Sears All In One Carpet Cleaner (82813) solution or Sears Upholstery Cleaner (82843) solution to Solution Tank (depending on type of cleaning to be performed). Follow directions on label of bottle.
3. Pour clean, hot water (from tap) into Filler Opening in the Solution Tank — use two (2) gallons of water.
4. Close Filler Opening.

NOTE: This unit may become damaged if boiling water is used.

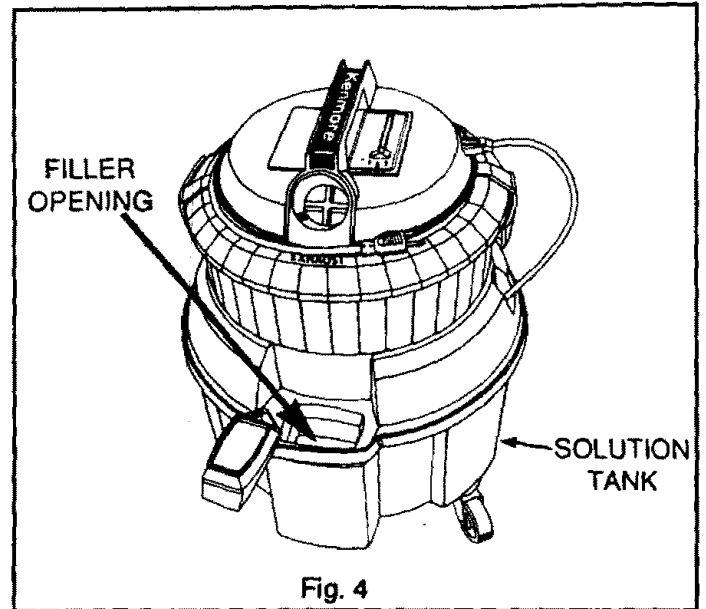

## POWER CORD AND SWITCH

See Figure 5

1. Plug Power Cord into electrical outlet.
2. Turn Power Switch to "ON" position.

## PUMP SWITCH

See Figure 5

1. Place Pump Switch from "OFF" position to either "HI" or "LO" position.

NOTE: "HI" pump speed is used for normal cleaning. "LO" pump speed is used for delicate upholstery or light cleaning.

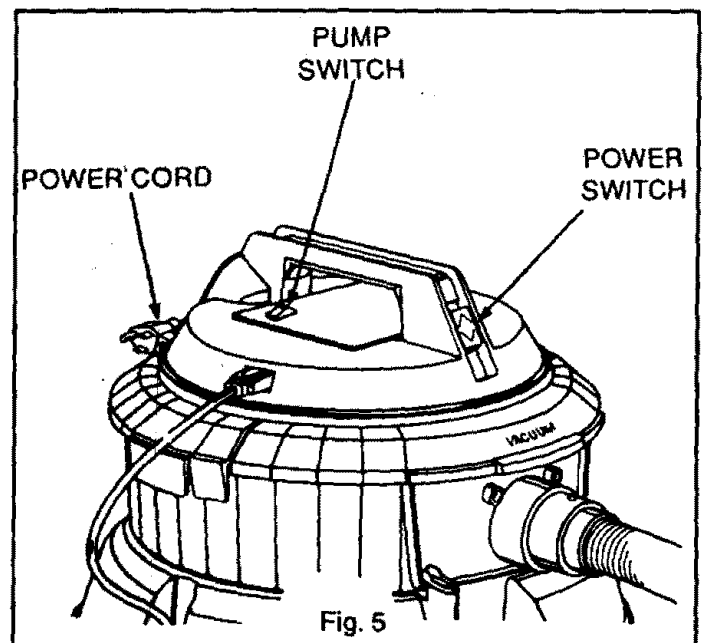

— Continued —

## TEST FOR SOLUTION SPRAY

See Figure 6

1. Hold Floor Nozzle above floor level.
2. Pull Solution Release Trigger on Angled Wand.
3. Observe Floor Nozzle to make sure cleaning solution is being sprayed evenly. (see *DETAIL "A"*)

NOTE: If solution is not being sprayed evenly, refer to Trouble Shooting Chart.

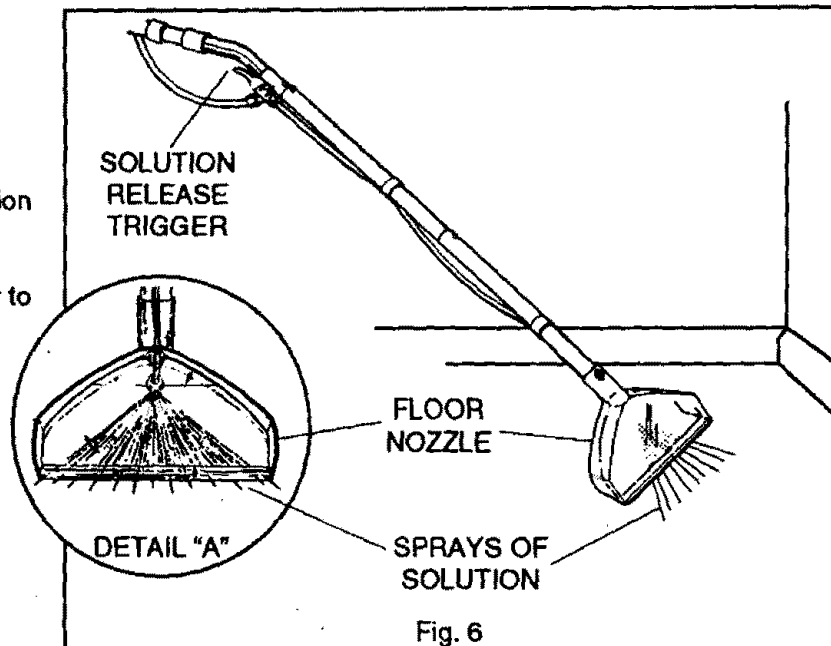

## CLEANING THE CARPET

See Figures 7 & 8

### Solution Dispensing Stroke:

1. Start at a corner (recommended).
2. Place Floor Nozzle so Suction Inlets are flush with carpet.
3. While exerting light pressure down on Floor Nozzle, depress Solution Release trigger and slowly pull Floor Nozzle towards you.

NOTE: Do not overwet. If three or more cleaning strokes are required, let dry and then repeat cleaning process.

### Solution Recovery Stroke:

1. Release Solution Release Trigger.
2. Lift Floor Nozzle off carpet.
3. Return Floor Nozzle to point where you dispensed cleaning solution and pull across carpet, recovering dirty solution.

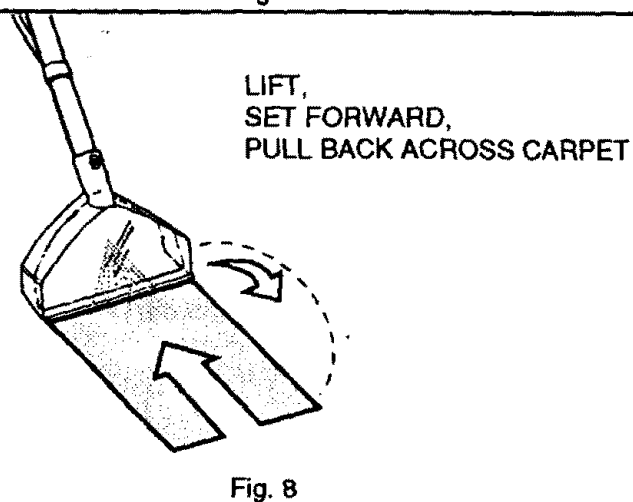
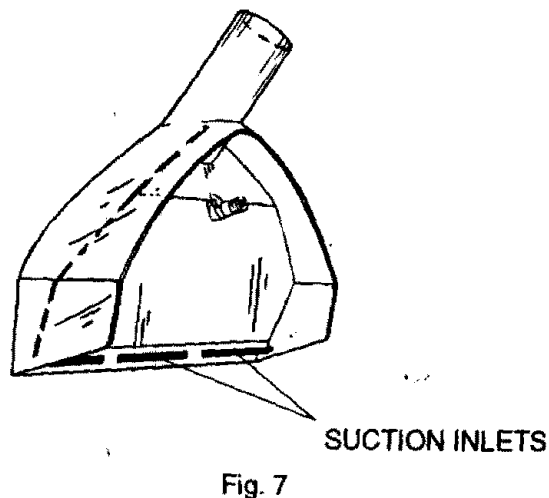

# OPERATION

## WHEN TO EMPTY RECOVERY TANK

See Figure 9

During normal operation, your cleaner may stop recovering solution from your carpet. When this occurs there are three check points to alert you:

1. An increase in motor noise.
2. No solution visibly being recovered by the floor nozzle.
3. No air coming from the exhaust port of your cleaner.

When this occurs:

1. The Recovery Tank is full and the Float Valve in the Recovery Tank has been activated. The Recovery Tank should be emptied.  
— or —
2. The Recovery Tank has foam in the Tank and the Float Valve has been activated.

NOTE: If cleaner is accidentally turned over while in operation, the float may activate and shut off the suction. If this occurs, set the cleaner upright. Turn Power Switch "OFF" and let motor come to a complete stop. Then turn switch back on and continue cleaning.

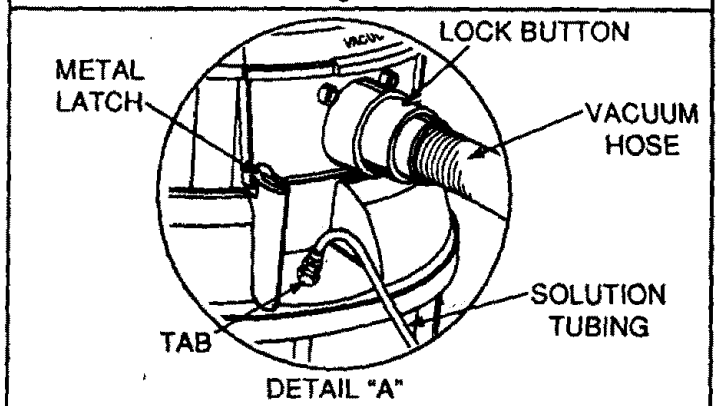
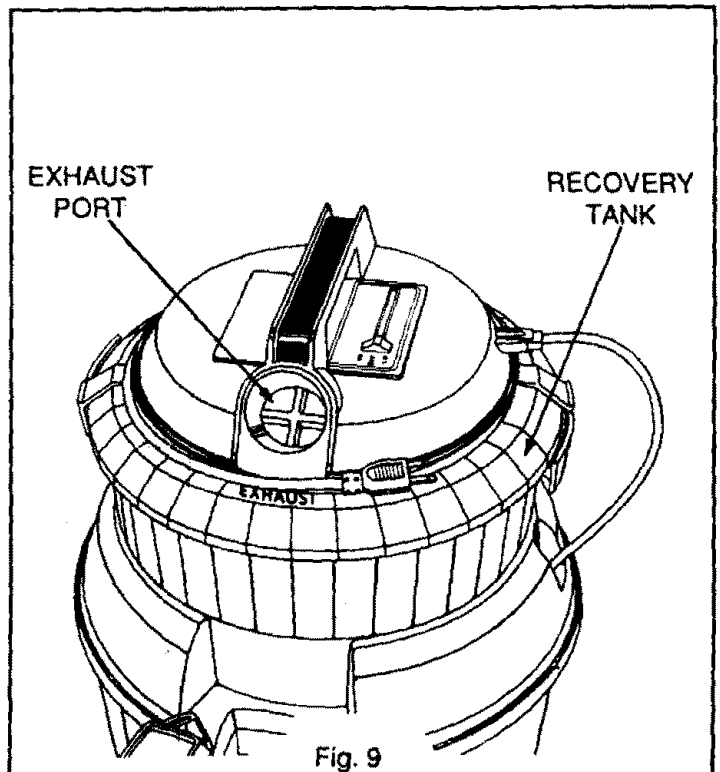

## TO EMPTY RECOVERY TANK

See Figure 10

1. Turn Power Switch "OFF" and Disconnect Power Cord from Electrical Outlet.
2. Disconnect Short Cord located between Solution Tank and Recovery Tank.
3. Disconnect Vacuum Hose by depressing the Lock Button and remove.
4. Push Tab inward on Plastic Coupling and remove Plastic Insert and Tubing. (See DETAIL "A")
5. Lift Latches on Power Head.
6. Lift power Head, by Handle, and remove from Recovery Tank.
7. Rotate Metal Latch on the Solution Tank and lift Recovery Tank from the Solution Tank.
8. Empty Recovery Tank.
9. Reassemble cleaner and resume cleaning. NOTE: Power Head is designed to go on in only one position. Make sure the word "VACUUM" on the Power Head is lined up directly over the Hose Inlet on Recovery Tank as shown in Fig. 10 or Power Head will not seal to unit properly.

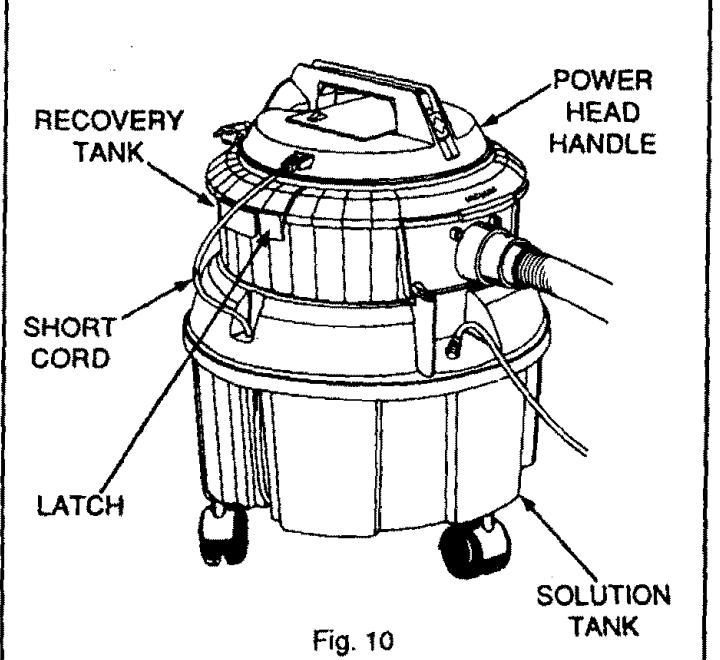

# OPERATION

## TO EMPTY THE SOLUTION TANK

See Figure 11

When cleaning is completed, both the Recovery Tank and the Solution Tank should be emptied prior to storage. Empty the Recovery Tank as described earlier. There are three methods of emptying the Solution Tank.

### Method 1:

1. Disconnect Pump Cord from Recovery Tank.
2. Remove Recovery Tank from Solution Tank and pour solution out of the Filler Opening.

### Method 2:

1. Place Floor Nozzle in bath tub or container.
2. Depress Solution Release Trigger and spray until empty.

### Method 3:

1. Remove Floor Nozzle and insert Wand into Solution Tank through the Filler Opening.
2. Vacuum solution out.
3. All solution is now in Recovery Tank. Empty Recovery Tank as described earlier.

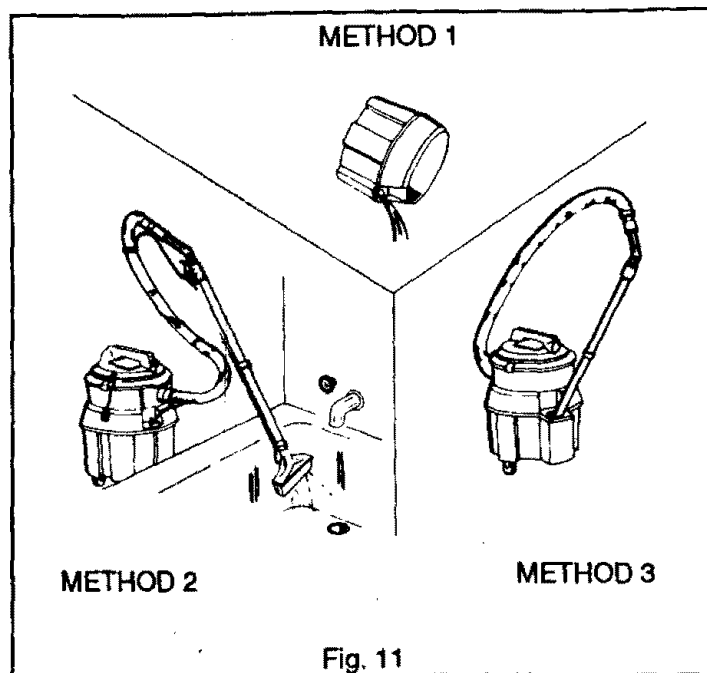

# ATTACHMENTS

## UPHOLSTERY NOZZLE

See Figure 12

Cleanmore Carpet Cleaner Upholstery Nozzle is an attachment for furniture upholstery cleaning. The upholstery nozzle may also be used to clean auto upholstery or carpeting. In addition, the nozzle may be used to clean carpeted stairs and other areas difficult to clean with the normal floor nozzle.

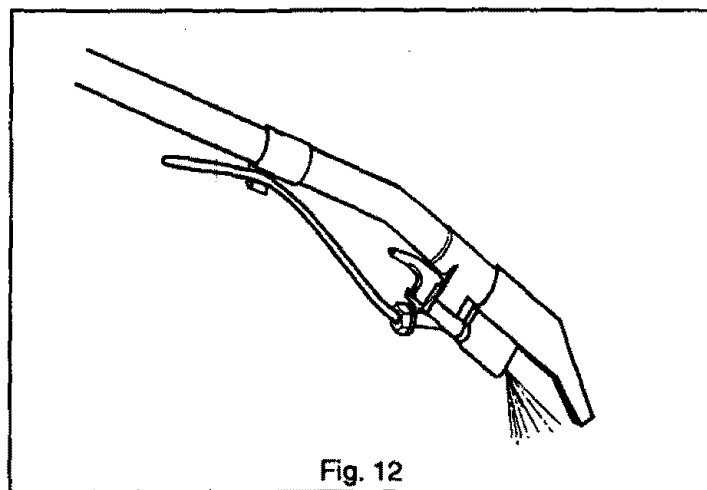

## FLOOR TOOLS

See Figure 13

The Bare Floor/Carpet Brush (1) may be used on floors without carpet for DRY cleaning with paper dust bag installed.

The Squeegee Attachment (2) is useful for WET pickup.

**CAUTION: DO NOT** run the Pump Motor when using these attachments. To prevent Pump Motor from operating, make sure Pump Motor Switch is in "OFF" position, or unplug the short Power Cord from the Solution Tank to the Recovery Tank.

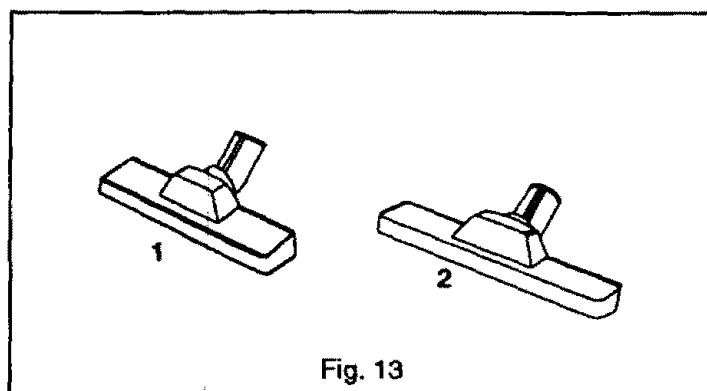



# DRY VACUUMING

## DRY FLOOR POWER NOZZLE

See Figure 14

Your cleaner comes with a DRY FLOOR Power Nozzle which has a motorized Beater Brush. Use Power Nozzle with the Paper Dust Bag below to convert your cleaner for regular household vacuuming.

**WARNING — DRY ONLY! TO REDUCE THE RISK OF ELECTRIC SHOCK, DO NOT USE DRY POWER NOZZLE ON WET SURFACES. CONNECT CLEANER TO A PROPERLY GROUNDED OUTLET. (SEE SAFETY INSTRUCTIONS ON PAGE 3.)**

POWER NOZZLE IS DOUBLE INSULATED. Should a need ever exist for repair or service, simply contact your nearest Sears Service Center.

1. Turn Power Switch OFF and disconnect Power Cord from electrical outlet.
2. INSTALL PAPER DUST BAG AS SHOWN BELOW.
3. Disconnect Short Cord Located between Solution Tank and Recovery Tank.
4. Remove Straps from Hose, disconnect Solution Tubing from Angled Wand and Solution Tank. (See step 4 under "To Empty Recovery Tank" on p.7)
5. Assemble two straight wands to Angled Wand and Power Nozzle.
6. Push Nozzle Power Cord into clips on Wands; route Cord up Vacuum Hose and secure with Straps.
7. Insert Plug of Nozzle Power Cord into receptacle on Recovery Tank Power Head (where Short Cord was plugged in).
8. Plug Vac Power Cord into electrical outlet.
9. Place Power Switch in "ON" position and Pump Switch in "HI" position (See Fig 5). When vacuuming bare floors, place Pump Switch in "OFF" position to prevent Beater Brush from rotating.

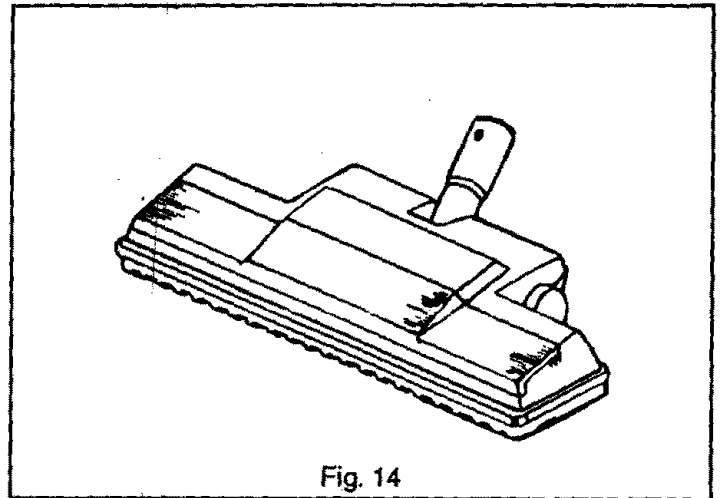

Fig. 14

**DO NOT USE THIS POWER NOZZLE WITHOUT PAPER DUST BAG IN PLACE.**

## PAPER DUST BAG (20-5086)

See Figure 15

This cleaner uses a disposable paper dust bag to trap and collect dirt when used for dry pick up. It is very important that the disposable paper dust bag remain clean to allow air to pass through it while trapping dirt. If the dust bag is over filled or its pores become clogged from fine powders, no air can pass through. This greatly reduces the efficiency of your cleaner and could cause the dust bag to burst. To maintain your cleaner's peak efficiency, check the disposable paper dust bag often and replace when clogged or approximately one half full.

### TO INSTALL PAPER DUST BAG

1. Turn Power Switch OFF and disconnect Power Cord from electrical outlet.
2. Lift Latches and remove Power Head from unit.
3. Grasp Cardboard Collar of Dust Bag and push Collar as far as possible onto Bag Adapter Tube. NOTE: For greater ease in assembly, slide bottom of Cardboard Collar onto Adapter Tube first, then pull top of Collar over Tube.
4. Position Dust Bag around sides of tank to allow motor

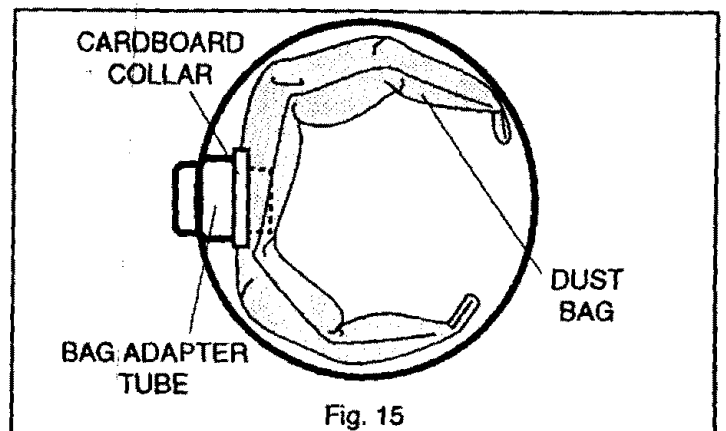

Fig. 15

assembly to fit back in unit.

5. Bend top flap of Cardboard Collar inward.
6. Replace Power Head on unit being careful not to crush Dust Bag or to deform flexible splash plate on Power Head.
7. Make sure the Pump Switch is turned "OFF" for Dry Vacuuming.

**CAUTION: PAPER DUST BAG IS FOR DRY PICK UP ONLY. DO NOT USE WHEN VACUUMING LIQUIDS!**

# ADDITIONAL USES

## USE AS A BLOWER

See Figure 16

1. Insert Hose into the Exhaust Port of the Power Head.
2. Turn Power Switch "ON" and direct hose to area to be blown.

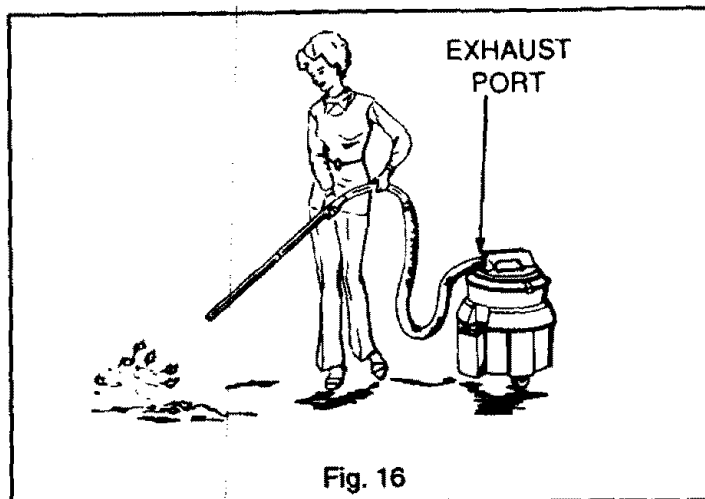

## OPTIONAL CLEANING ACCESSORIES

### KENMORE SPRAYMATE ATTACHMENT

Model No. 2083252

See Figure 17

Cleanmore Spraymate is an optional attachment for carpet cleaning. The Cleanmore Spraymate has a motorized beater brush which is especially good for difficult to clean areas of heavy traffic.

Optional cleaning accessories may be purchased or ordered through your nearest Sears store. A complete set of instructions comes with each attachment set.

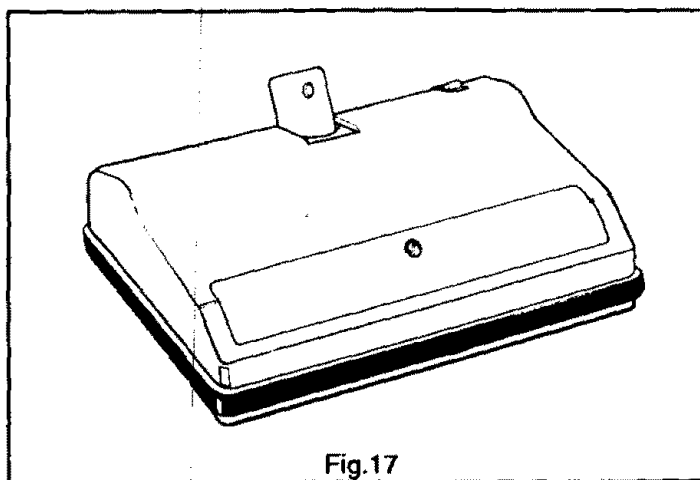

# TROUBLE SHOOTING CHART

PROBLEM	POSSIBLE SOLUTIONS*
1. Neither vacuum motor nor pump motor runs.	<ol style="list-style-type: none"> <li>1. Be sure power switch is in "ON" position.</li> <li>2. Be sure power cord is plugged in securely.</li> <li>3. Check wall electrical outlet (by plugging in a known working electrical appliance).</li> </ol>
2. Vacuum motor runs, but there is no spray at the nozzle.	<ol style="list-style-type: none"> <li>1. Be sure Electrical Cord from Power Head to Solution Tank is securely plugged into receptacle on the Power Head.</li> <li>2. Check that Solution Tank is full.</li> <li>3. Be sure Pump Switch is in the "HI" or "LO" position.</li> <li>4. Nozzle Ports may be clogged. See illustration below to unclog.</li> </ol>
3. Spray from the floor nozzle does not come out evenly.	<ol style="list-style-type: none"> <li>1. Unclog the Nozzle Port. See illustration below.</li> </ol>
4. Motor runs but cleaner does not pick up solution from carpet (no exhaust from top of cleaner).	<ol style="list-style-type: none"> <li>1. Recovery Tank is full of dirty water and must be emptied.</li> <li>2. Check for clogged hose or nozzle. Clogs could result from picking up material such as carpet strings, shoe laces, etc.</li> </ol>
5. Spray connections leak.	<ol style="list-style-type: none"> <li>1. Disassemble nut at leaking connection. Be sure washer is properly seated. Reassemble and tighten securely.</li> </ol>

\* If the "Possible Solutions" to "Problems" listed in the chart do not correct the problem, take your cleaner to a Sears Service Center for professional service. Repairs not listed in this chart require professional and specific knowledge of this model cleaner and could result in safety hazards and personal injury if not made by a qualified Sears Service Technician.

## TO UNCLOG NOZZLE PORT

See Figure 18

1. Insert the point of a needle or pin into Spray Port to unclog.

NOTE: Do not let the point of needle or pin touch any part of the Spray Pad surface or Spray Pad will not spray solution properly.

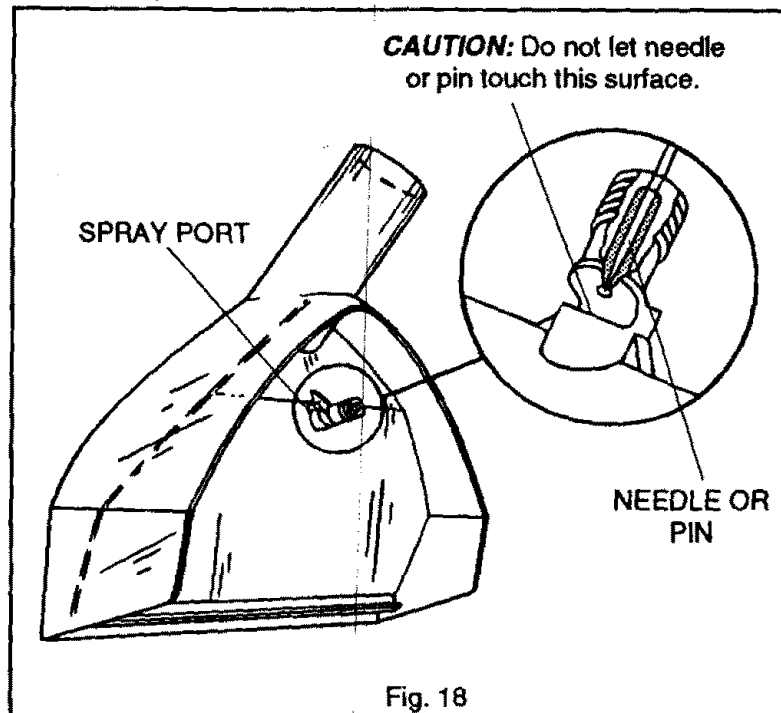

SEARS HOME CLEANING SYSTEM — MODEL 175.8690090

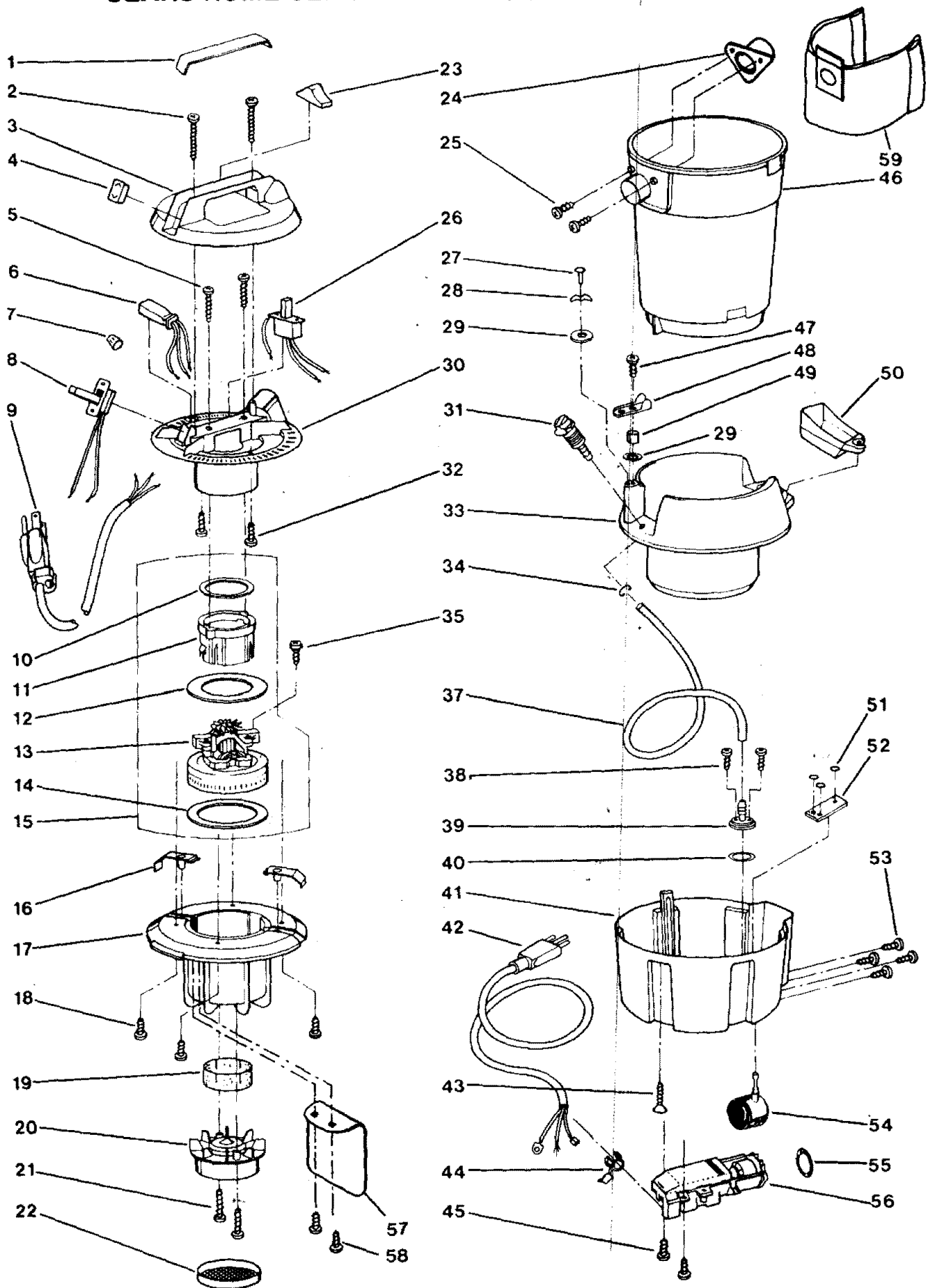

FIGURE A

# SEARS HOME CLEANING SYSTEM — MODEL 175.8690090

## Figure A Parts List (See Page 12 for Exploded View)

KEY	PART NO.	DESCRIPTION	KEY	PART NO.	DESCRIPTION
1	644147-004	Handle Plate	31	644773-008	Coupling Body
2	642337-002	Handle Screws (2)	32	640145-005	Separator Plate Screws (2)
3	642338-045	Handle Shroud w/Label	33	643565-020	Upper Container w/ Filler Door
4	642315-012	Switch Cap	34	643561-000	Retaining Ring
5	662267-001	Motor Housing Screws (2)	35	644802-001	Ground Lead Screw
6	643492-003	Female Pigtail	37	643562-003	Tubing Asm. w/ #39, 34
7	642149-001	Wiring Nut	38	643535-001	Valve Seat Screws (2)
8	643509-001	Switch	39	643438-002	Valve Seat
9	641843-010	Power Cord w/terminal	40	643536-000	Gasket
10	642367-006	Motor Seal	41	643566-015	Lower Container
11	644548-001	Motor Cover	42	643531-006	Pigtail
12	642367-004	Motor Seal	43	643533-002	Lower Container Screws (3)
13	643909-902	Carbon Brush Asm.	44	888493-304	Strain Relief
14	642367-004	Motor Seal	45	643685-001	Motor Screws (2)
15	642406-019	Motor Asm. Complete	46	642046-016	Dirt Container
16	641857-012	Latch (2)	47	989629-002	Latch Screw
17	641866-042	Cover Asm. w/ # 19, 20, 21, 22	48	660081-002	Latch
18	642409-002	Cover Screws (4)	49	640940-001	Spacer
19	643584-000	Foam Filter	50	643431-010	Filler Door
20	642405-001	Valve Asm. w/ #21, 22	51	643454-003	Washers (3)
21	643579-002	Valve Screws (2)	52	643583-000	Foam Filter
22	642313-000	Sensor Guard	53	643685-001	Motor Screws (4)
23	642713-005	Pump Switch Cap	54	661393-001	Casters (3)
24	662252-001	Bag Adapter	55	643171-003	"O" Ring Gasket
25	968702-007	Screws (2)	56	644089-015	Pump Motor
26	644846-004	Two Speed Switch - Pump w/Switch Cap	57	662381-001	Splash Plate
27	642470-006	Rivet	58	968702-007	Screw (2)
28	640218-005	Wave Washer	59	20-50500	Disposable Dust Bag
29	706382-319	Washer (2)		661654-067	Owner's Manual
30	642339-055	Separator Plate w/Key #8			

## Figure B Parts List (See Page 14 for Exploded View)

KEY	PART NO.	DESCRIPTION	KEY	PART NO.	DESCRIPTION
1	662257-001	Angled Wand w/ Key # 2, 14	17	662264-001	Valve Shut Off
2	662262-001	Trigger	18	662263-001	Spring, Valve
3	644037-002	Ferrule Nut (2)	19	643186-018	Straight Wands (2)
4	644848-006	Swivel Connector 1 - 1/4" dia.	20	643571-013	Nozzle Asm. Complete w/ Key # 3, 12,13
5	643731-005	Tubing Strap	21	644159-003	Retaining Clip
6	644038-003	Tubing - Hose	22	662368-001	Dry Floor Tool
7	644773-005	Coupling Insert Nut	23	642458-005	Wet Floor Tool
8	644773-007	Coupling Insert	24	641671-021	Crevice Tool
9	643502-009	Swivel Connector 2 - 1/2" dia.	25	662149-002	Dust Brush
10	643570-023	Hose and Angled Wand Asm.	26	662148-002	Dry Upholstery Tool
11	642963-019	8' Hose	27	662260-002	Wet Upholstery Tool
12	663324-001	Ferrule Nut	28	663324-701	Nut
13	644038-001	Tubing - to Nozzle	29	662266-002	"O" Ring
14	643572-007	Valve Asm. Kit w/trigger	30	661067-010	Dry Power Nozzle
15	662266-001	"O" Ring	31	643737-013	Wet Upholstery Tool Complete
16	662266-002	"O" Ring (2)		661654-067	Owner's Manual

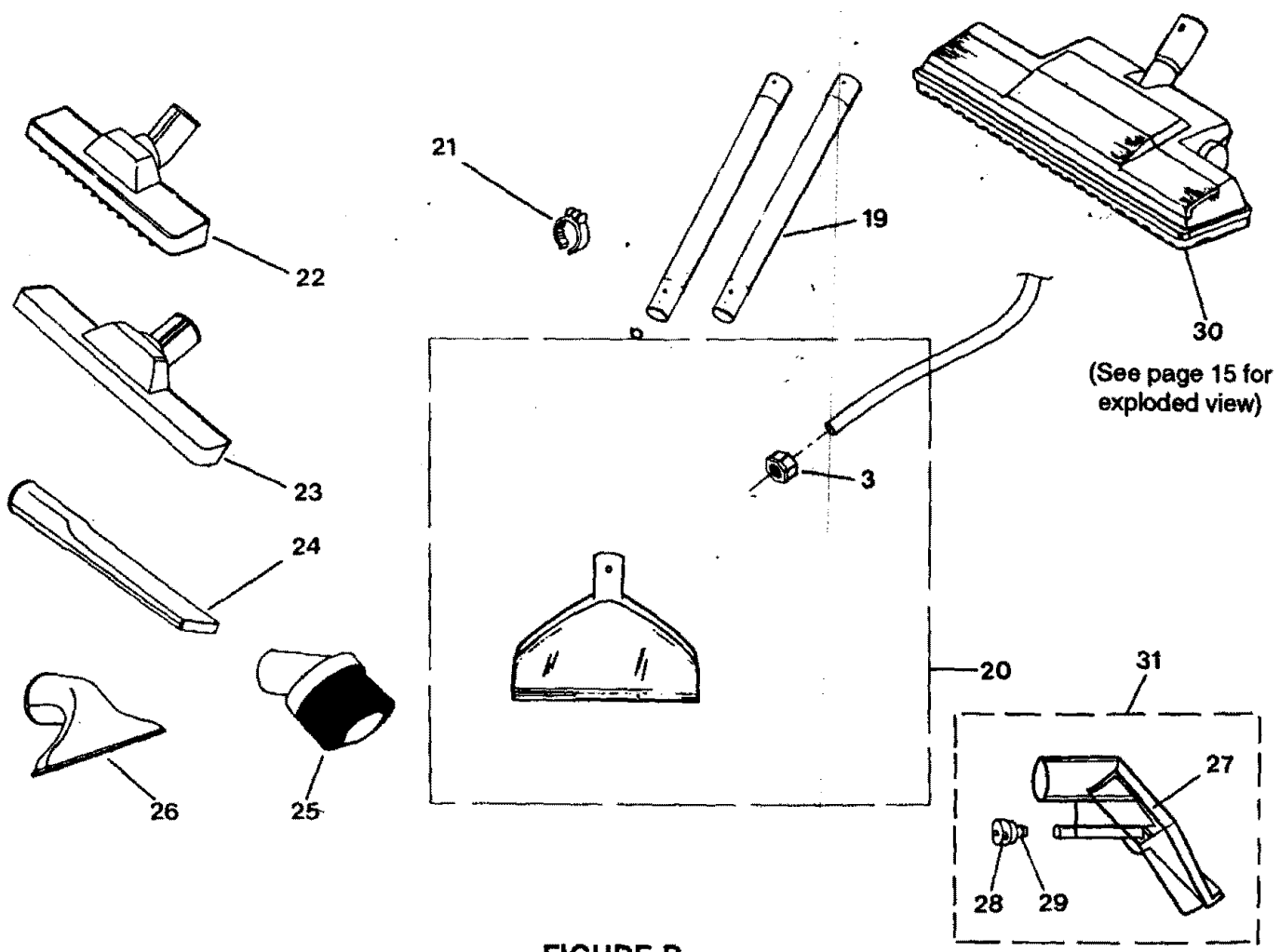
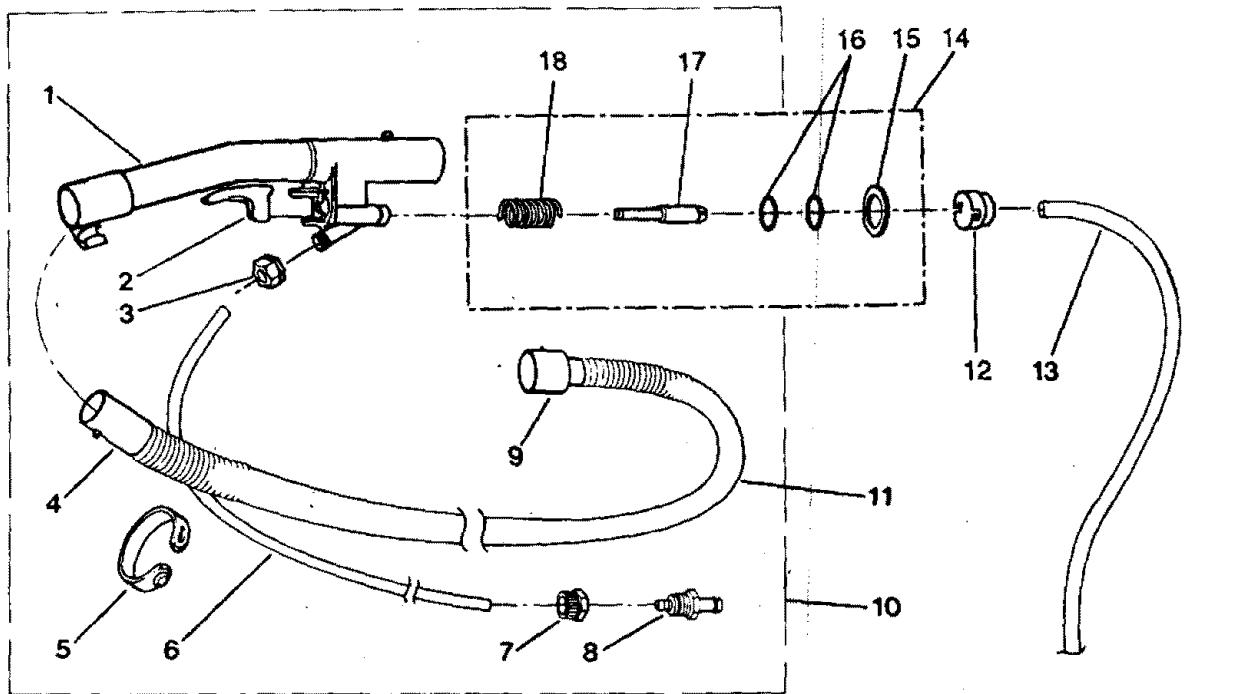
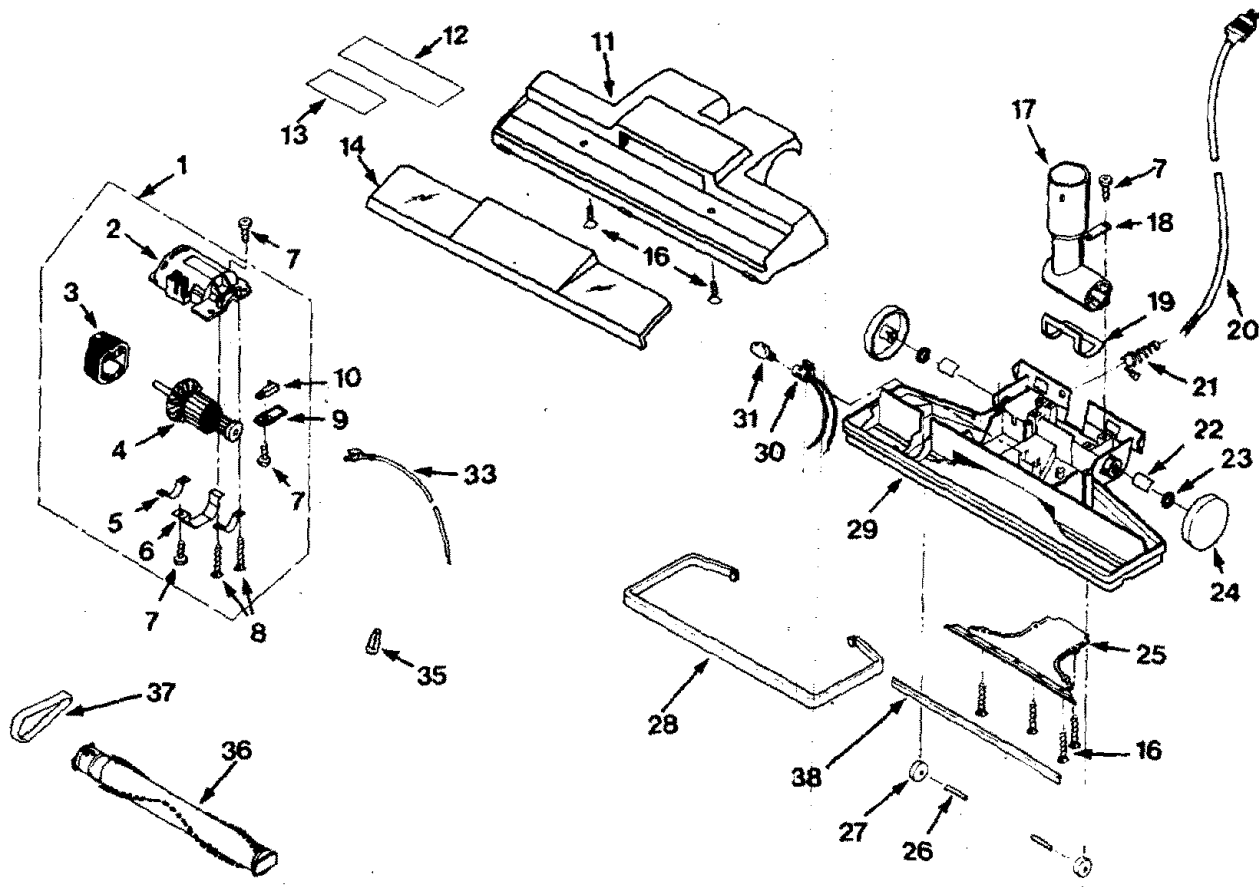

FIGURE B

# SEARS DRY POWER NOZZLE — MODEL SP-80PS



Key Part No.	Description
1	660694-902 Motor Complete
2	660685-002 Motor Housing
3	999349-003 Field
4	999350-002 Armature
5	661652-001 Bearing Strap (2)
6	660697-001 Field Strap
7	643526-002 Screw, Pan Head (13)
8	644338-001 Screw, Flat Head (4)
9	607182-001 Clamp (2)
10	661964-001 Carbon Brush Asm. (2)
11	661525-004 Top Cover
12	661497-001 Reflector
13	661496-001 Reflector
14	661523-001 Lens
16	643146-002 Screw, Flat Head (6)
17	661061-006 Swivel
18	661130-001 Swivel Strap (2)

Key Part No.	Description
19	661129-001 Swivel Seal
20	662464-001 Power Cord
21	661262-001 Strain Relief
22	661679-001 Wheel Bushing (2)
23	661082-001 Felt Washer (2)
24	660688-007 Rear Wheel (2)
25	661124-005 Volute Cover
26	661392-001 Shaft, Front Wheel (2)
27	661391-001 Front Wheel (2)
28	660689-009 Bumper
29	661524-705 Chassis
30	966770-002 Socket
31	966790-001 Light Bulb
33	661649-001 Lead, White
35	642149-001 Wire Nut, Black (3)
36	661685-001 Floor Brush Asm
37	SMB-4 Belt

# SEARS

OWNERS  
MANUAL

SERVICE

MODEL NO.  
175.8690090

HOW TO ORDER  
REPAIR PARTS

# Kenmore

## HOME CLEANING SYSTEM

Now that you have purchased your Kenmore Home Cleaning System, should a need ever exist for repair parts or service, simply contact any Sears Service Center. Be sure to provide all pertinent facts when you call or visit.

The **model number** of your Power Spray Cleaner will be located on the Power Head of the cleaner.

WHEN ORDERING REPAIR PARTS, ALWAYS GIVE THE FOLLOWING INFORMATION:

- |                               |   |
|-------------------------------|---|
| • PART NUMBER                 | • PART DESCRIPTION                                |
| • MODEL NUMBER<br>175.8690090 | • NAME OF ITEM<br>Kenmore<br>Home Cleaning System |

All parts listed may be ordered from any Sears Service Center.

If the parts you need are not stocked locally, your order will be electronically transmitted to a Sears Repair Parts Distribution Center for handling.