

Owner's Manual

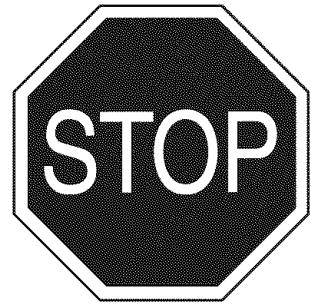

42" LAWSWEEPER

Model No's. 486.242211



DO NOT RETURN TO STORE
For Missing Parts or Assembly
Questions Call 1-866-576-8388

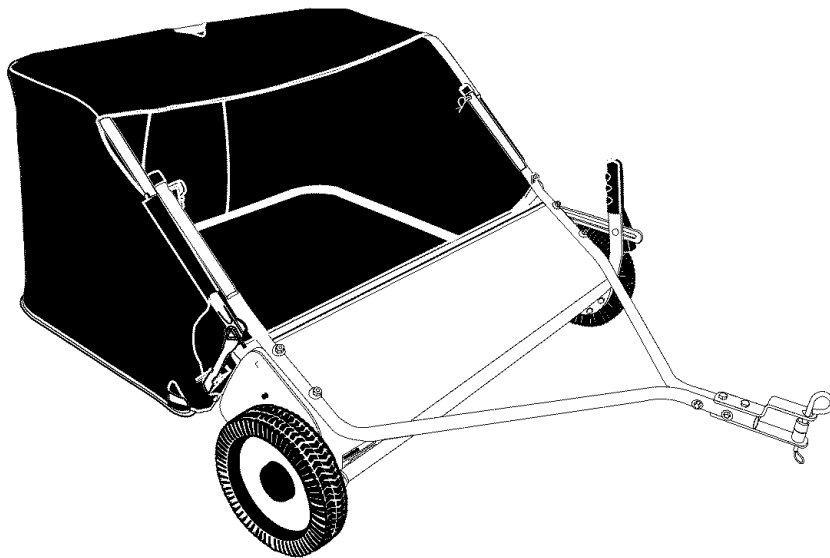

CAUTION:

Before using this product, read this manual and follow all Safety Rules and Operating Instructions.

- Safety
- Assembly
- Operation
- Maintenance
- Parts

Sears, Roebuck and Co., Hoffman Estates, IL 60179 U.S.A.
www.sears.com/craftsman

TABLE OF CONTENTS

| | | | |
|-------------------------------------|----|---------------------------------|------------|
| Safety Rules | 2 | Maintenance Schedule | 13 |
| Accessories and Attachments | 3 | Storage | 13 |
| Carton Contents | 3 | Service and Adjustments | 14 |
| Full Size Hardware Chart | 4 | Troubleshooting | 14 |
| Sweeper Assembly Instructions | 5 | Repair Parts Illustration | 16 |
| Hopper Assembly Instructions | 8 | Repair Parts List | 17 |
| Operation | 12 | Parts Ordering/Service | Back Cover |

WARRANTY

ONE YEAR FULL WARRANTY

When assembled, operated and maintained according to the supplied instructions, if this Craftsman Lawnsweeper fails due to a defect in material or workmanship within one year from the date of purchase, call 1-800-4-MY-HOME to arrange for free repair (or replacement if repair proves impossible).

This warranty is void if this product is ever used for commercial or rental purposes.

This warranty applies only while this product is used in the United States.

This warranty gives you specific legal rights, and you may also have other rights which vary from state to state.

Sears, Roebuck and Co., Dept. 817WA, Hoffman Estates, IL 60179



SAFETY



Any power equipment can cause injury if operated improperly or if the user does not understand how to operate the equipment. Exercise caution at all times, when using power equipment.

1. Read the vehicle and sweeper owners manuals and know how to operate your vehicle and sweeper before using this sweeper attachment. Always instruct other users before they operate the sweeper.
2. Do not permit children to operate sweeper.
3. Do not permit anyone to ride on sweeper.
4. Never attach the hopper rope to any part of your body or clothing! Never hold onto the rope while towing the sweeper! Attach the rope to the towing vehicle to keep it away from wheels and rotating parts.
5. Operate the sweeper at reduced speed on rough terrain, near ditches and on hillsides to prevent loss of control.
6. Vehicle braking and stability may be affected with the attachment of this sweeper. Do not fill sweeper to maximum capacity without checking the capability of the towing vehicle to safely pull and stop with the sweeper attached. **Stay off of steep slopes.**
7. Stop and inspect vehicle and sweeper for damage after striking an object. Repair any damage before continuing operation.
8. Keep sweeper away from fire. Excessive heat can damage the brushes and hopper bag and could cause the bag and its contents to burn.
9. Before storing the sweeper, always empty the hopper bag to avoid spontaneous combustion.
10. Follow maintenance and lubrication instructions as outlined in the maintenance section of this manual.



Look for this symbol to point out important safety precautions. It means — **Attention!!**
Become alert!! Your safety is involved.

The model and serial numbers will be found on a decal attached to the lawnsweeper.

You should record both the serial number and the date of purchase and keep in a safe place for future reference.

MODEL NUMBER: 486.242211

SERIAL NUMBER: _____

DATE OF PURCHASE: _____

ACCESSORIES AND ATTACHMENTS

These accessories were available when the unit was purchased. They are also available at most Sears retail outlets and service centers. Most Sears stores can order repair parts for you when you provide the model numbers of your tractor and sweeper.

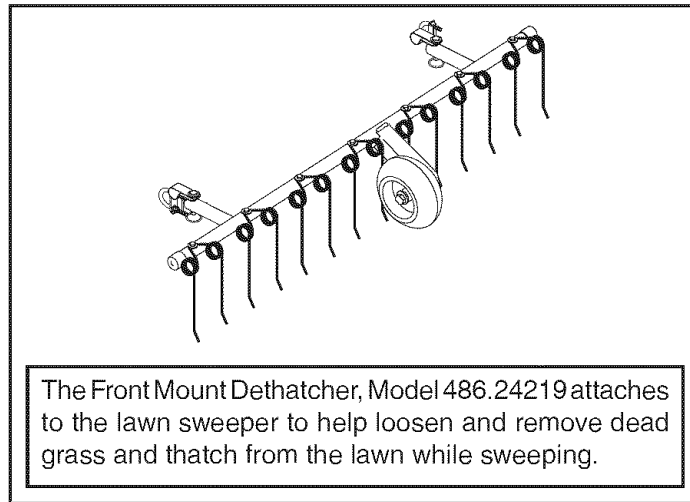

The Front Mount Dethatcher, Model 486.24219 attaches to the lawn sweeper to help loosen and remove dead grass and thatch from the lawn while sweeping.

CARTON CONTENTS (Loose Parts in Carton)

- | | | |
|-----------------------------|--------------------------------|--------------------------------|
| 1. Sweeper Housing Assembly | 7. Height Adjustment Handle | 13. Lower Hopper Side Tube (2) |
| 2. Bag Arm Tube (2) | 8. Right Hitch Tube | 14. Hopper Support Rod (2) |
| 3. Left Hitch Tube | 9. Rear Support Brace | 15. Bag Frame Strap |
| 4. Hitch Bracket | 10. Brush Assembly (2) | 16. Hopper Bag |
| 5. Hitch Bracket (Straight) | 11. Upper Hopper Side Tube (2) | 17. Rope |
| 6. Height Adjustment Strap | 12. Rear Hopper Tube (2) | |

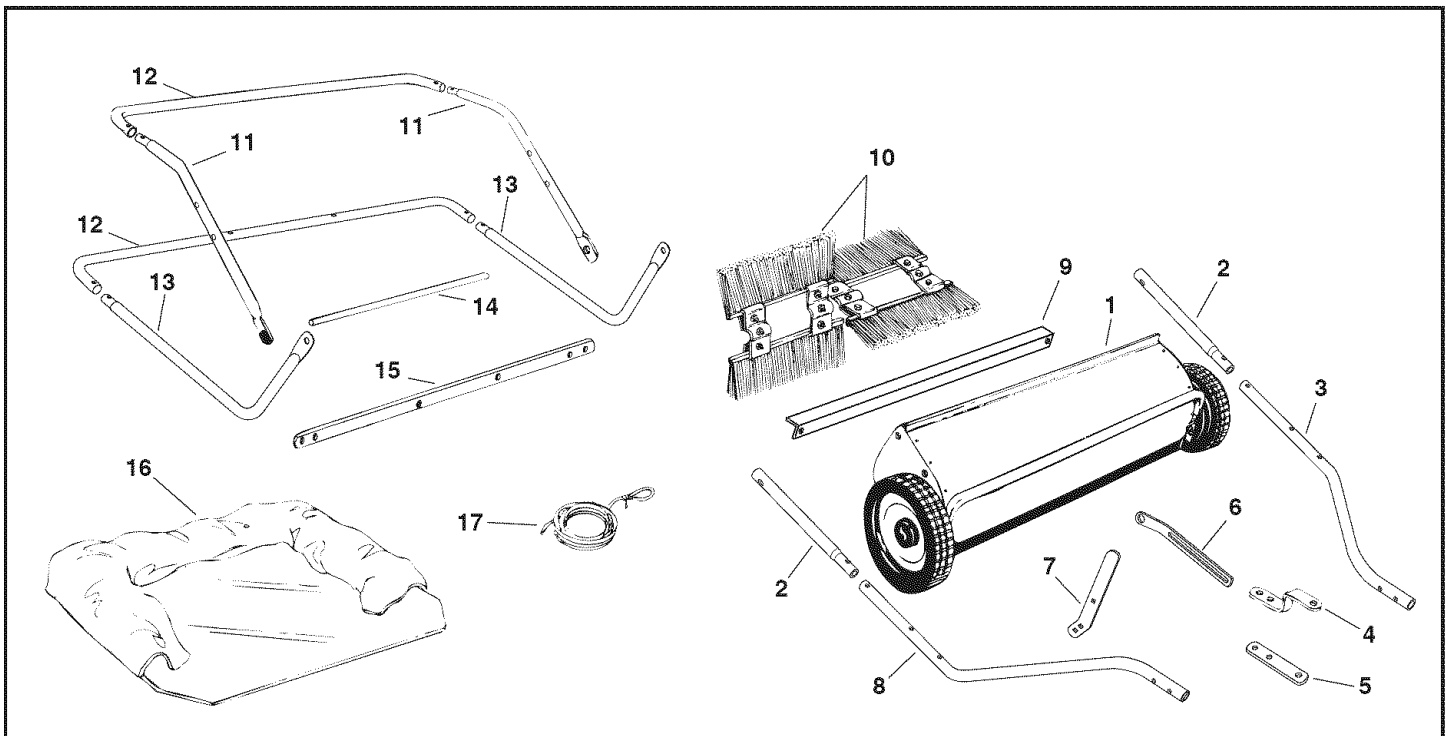

HARDWARE PACKAGE CONTENTS

SHOWN FULL SIZE

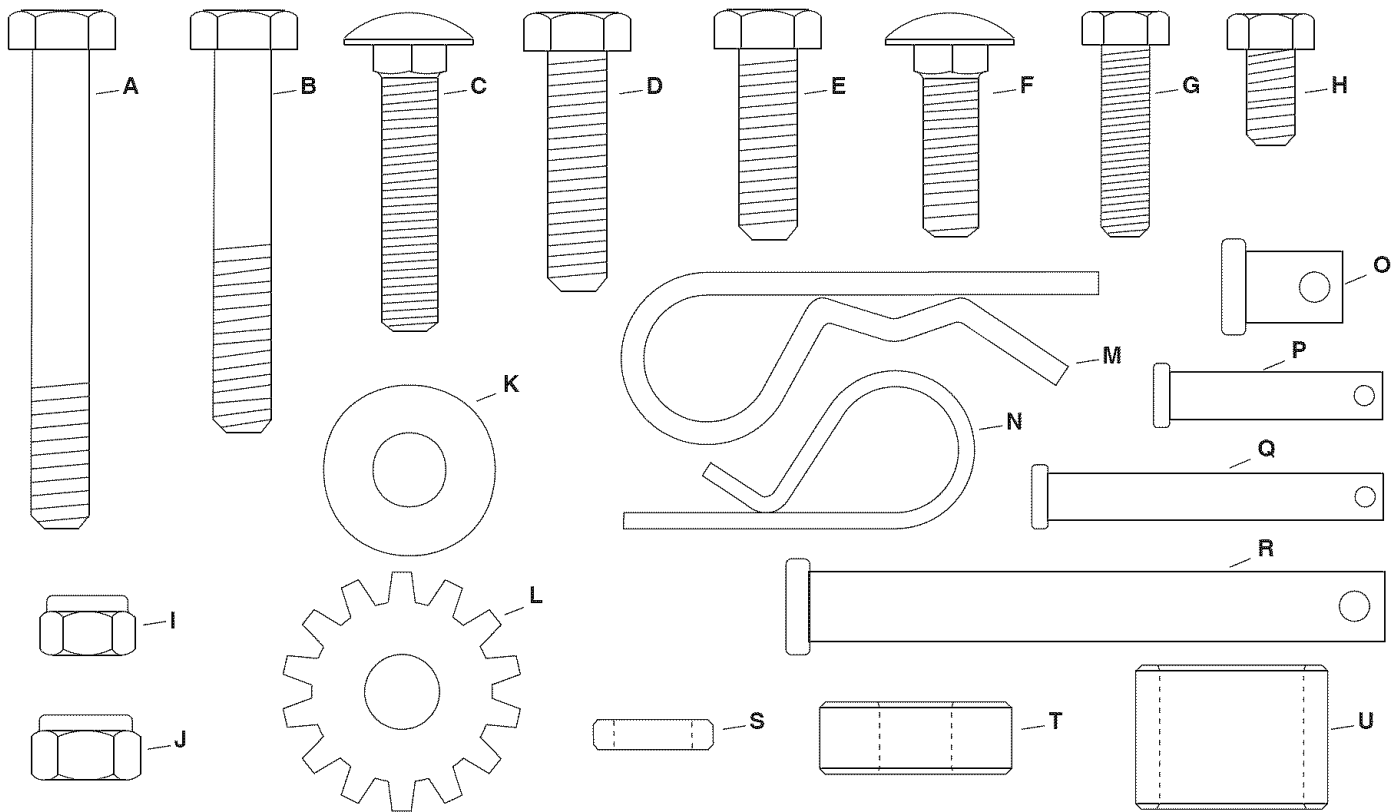

NOT SHOWN FULL SIZE

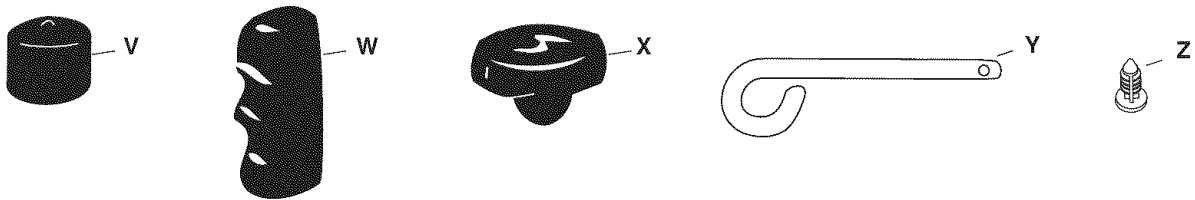

| REF | QTY | DESCRIPTION | REF | QTY | DESCRIPTION |
|-----|-----|-------------------------------|-----|-----|---------------------------|
| A | 2 | Hex Bolt, 5/16 x 2-1/2" Lg. | N | 8 | Hair Cotter Pin, 3/32" |
| B | 2 | Hex Bolt, 5/16 x 2" Lg. | O | 2 | Clevis Pin, 3/8" x 1/2" |
| C | 4 | Carriage Bolt, 5/16" x 1-1/2" | P | 2 | Clevis Pin, 1/4" x 1-1/8" |
| D | 1 | Hex Bolt, 5/16" x 1-1/4" Lg. | Q | 2 | Clevis Pin, 1/4" x 1-3/4" |
| E | 2 | Hex Bolt, 5/16" x 1" | R | 2 | Clevis Pin, 3/8" x 3" |
| F | 1 | Carriage Bolt, 5/16" x 1" | S | 1 | Pivot Bushing |
| G | 4 | Hex Bolt, 1/4" x 1" | T | 1 | Spacer Bushing |
| H | 2 | Hex Bolt, 1/4" x 1/2" | U | 2 | Hitch Spacer, 3/4" |
| I | 6 | Nylock Nut, 1/4" | V | 2 | Vinyl Cap |
| J | 11 | Nylock Nut, 5/16" | W | 1 | Grip |
| K | 4 | Flat Washer, 5/16" | X | 1 | Knob, Plastic |
| L | 1 | Star Washer | Y | 1 | Hitch Pin |
| M | 1 | Hair Cotter Pin, 1/8" | Z | 4 | Plastic Plug |

ASSEMBLY

TOOLS REQUIRED FOR ASSEMBLY

- (2) 7/16" Open End or Box End Wrenches
- (2) 1/2" Open End or Box End Wrenches

REMOVE PARTS FROM CARTON

- To protect painted parts, lay them on cardboard or a mat.
- Remove the sweeper housing, the loose parts and the hardware package from the carton. Lay out the parts and hardware as shown on pages 3 and 4.

STEP 1: (SEE FIGURE 1)

- Assemble the rear support brace to the holes indicated in the sweeper housing. Use two 1/4" x 1/2" hex bolts (H) and 1/4" nylock nuts (I).

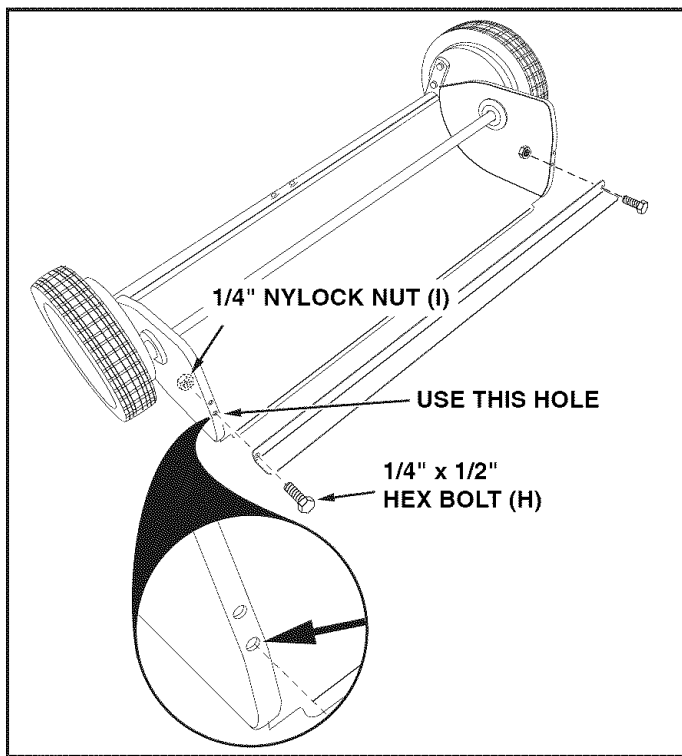

FIGURE 1

STEP 2: (SEE FIGURE 2)

- Each brush assembly has one brush retainer marked with either red or black ink. Lay out the brush assemblies as shown so that the brush retainers marked with ink are in the middle with the red one on the right and the black one on the left.

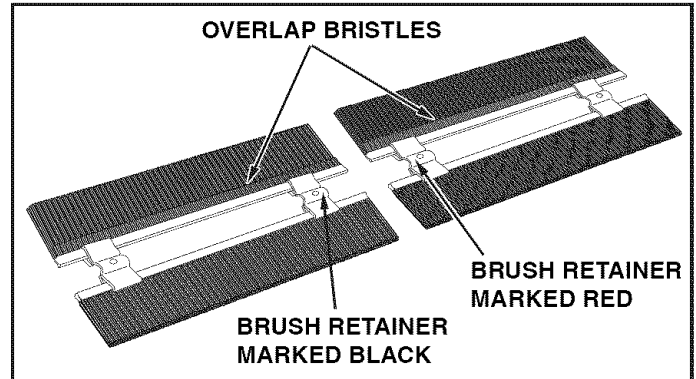

FIGURE 2

IMPORTANT: The overlap bristles at the bottom of each brush help support the back side of the brush for better sweeper performance. Be sure the sweeper is turned as shown in figures 2 and 3 to correctly assemble the brushes.

STEP 3: (SEE FIGURE 3)

- Attach the brush assembly with the red brush retainer to the right end of the brush shaft using two 1/4" x 1" hex bolts (G) and 1/4" nylock nuts (I). The brush retainer marked with red ink must be placed to the **middle** of the sweeper.

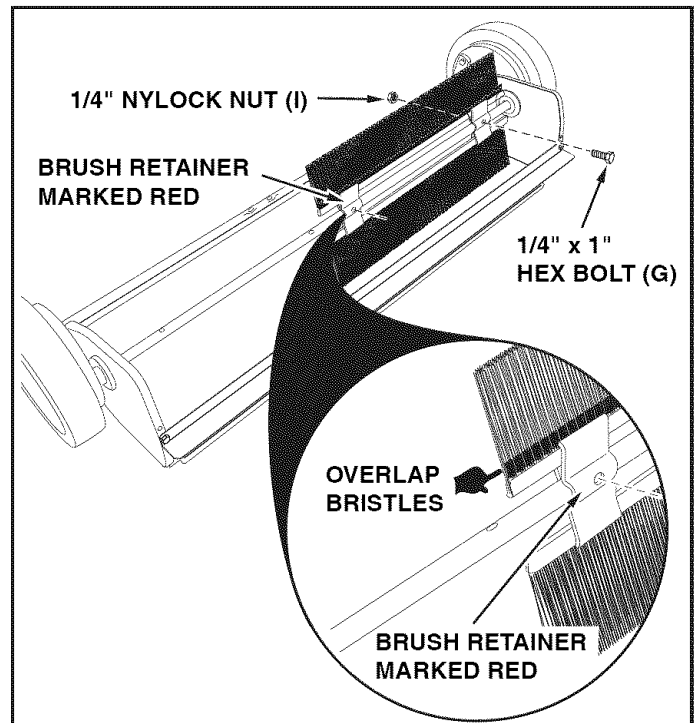

FIGURE 3

STEP 4: (SEE FIGURE 4)

- Attach the brush assembly with the black brush retainer to the left end of the brush shaft using two 1/4" x 1" hex bolts (G) and 1/4" nylock nuts (I). The brush retainer marked with black ink must be placed to the **middle** of the sweeper.
- Turn a wheel to rotate the brushes. (The wheels drive the brushes in one direction only.) The overlap bristles should be on the back side of the brush as it rotates.

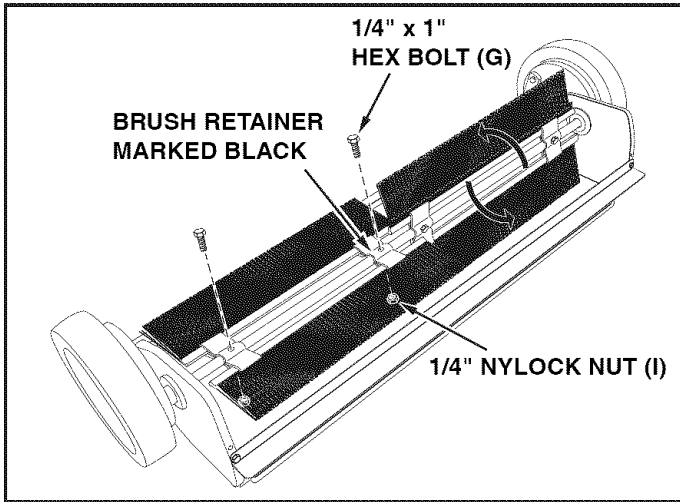

FIGURE 4

STEP 5: (SEE FIGURE 5)

- Cut off the plastic tie that holds the height adjustment tube in place.
- Assemble the R.H. hitch tube to the sweeper housing using two 5/16" x 1-1/2" carriage bolts (C), and two 5/16" nylock nuts (J). **Do not tighten yet.** Repeat for the L.H. hitch tube.

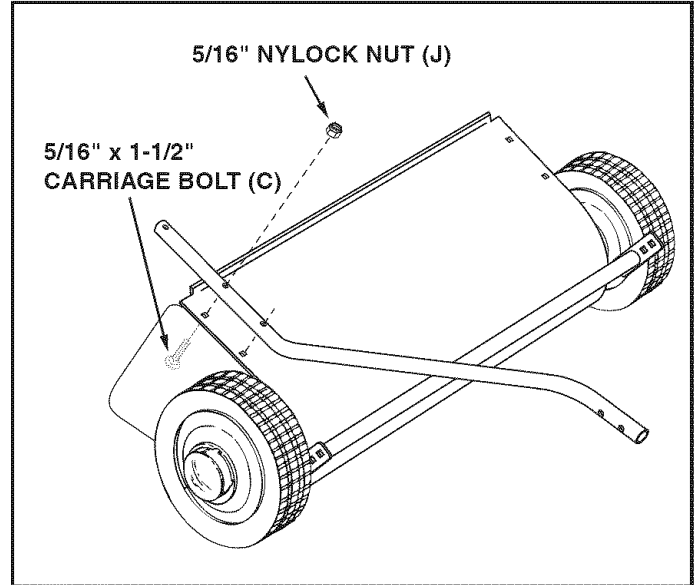

FIGURE 5

STEP 6: (SEE FIGURE 6)

- Fasten the hitch tubes together using two 5/16" x 2-1/2" hex bolts (A) and 5/16" nylock nuts (J). **Do not tighten yet.**

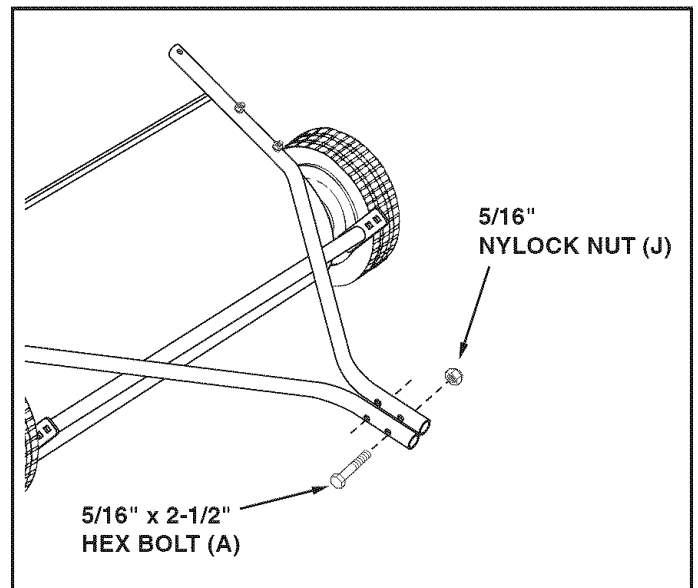

FIGURE 6

STEP 7: (SEE FIGURE 7 AND 8)

If your tractor hitch has 10" to 13" ground clearance refer to figure 7. If your tractor hitch has 8" to 10" ground clearance refer to figure 8.

- Assemble the hitch brackets to the hitch tubes using two 5/16" x 2" hex bolts (B) and 5/16" nylock nuts (J). The bolts should straddle the front hitch tube bolt. **Do not tighten yet.**
- At this time **tighten** the four bolts fastening the hitch tubes to the sweeper housing. Next, **tighten** the two bolts fastening the ends of the hitch tubes together. Finally, **tighten** the two bolts fastening the hitch brackets to the hitch tubes.
- Assemble the hitch pin (Y), two 3/4" hitch spacers (U) and the 1/8" hair cotter pin (M) to the hitch brackets.

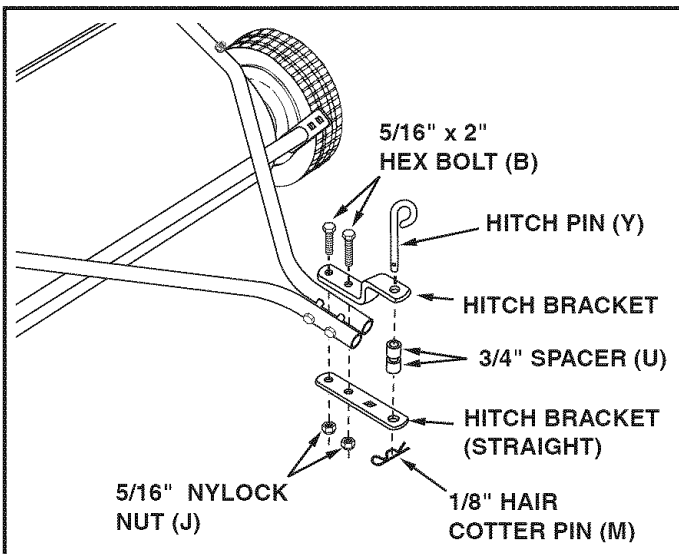

FIGURE 7

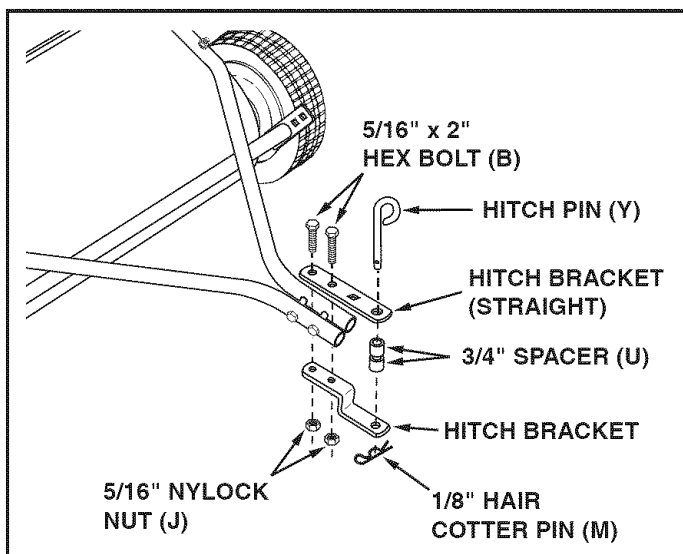

FIGURE 8

STEP 8: (SEE FIGURE 9)

- Assemble the height adjustment handle to the **inside** of the bracket on the end of the height adjustment tube. Use two 5/16" x 1" hex bolts (E), 5/16" flat washers (K) and 5/16" nylock nuts (J). **Tighten.**
- Assemble the grip (W) onto the height adjustment handle.

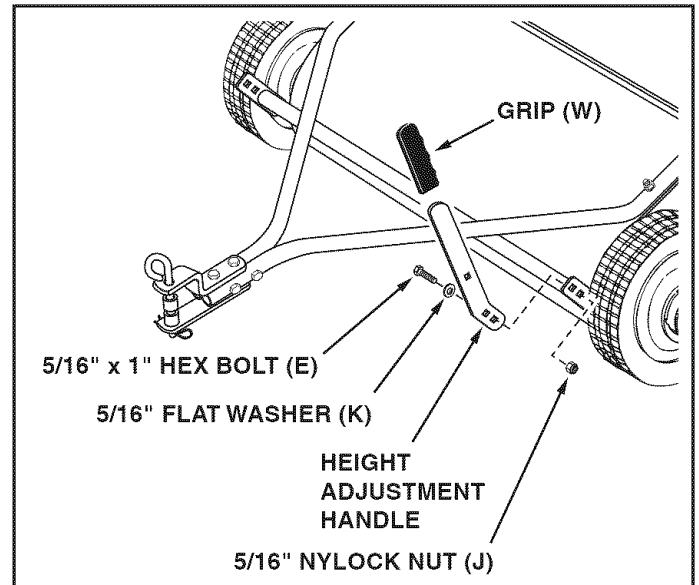

FIGURE 9

STEP 9: (SEE FIGURE 10)

- Assemble onto a 5/16" x 1-1/4" hex bolt (D) in the order listed, a 5/16" flat washer (K), the pivot bushing (S), the height adjustment strap and the spacer bushing (T). Insert the bolt through the upper part of the double hole in the end of the sweeper housing and secure it with a 5/16" nylock nut (J). **Tighten.**

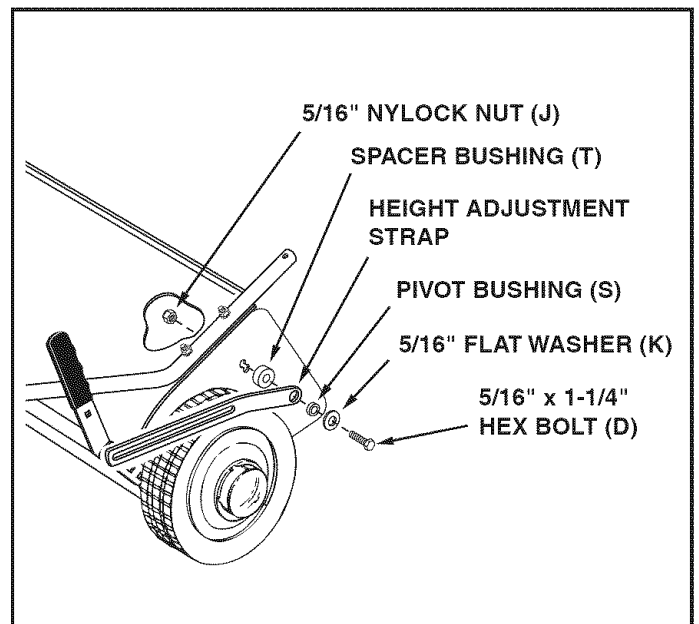

FIGURE 10

STEP 10: (SEE FIGURE 11)

- Place the star washer (L) between the height adjustment handle and the height adjustment strap. Insert the 5/16" x 1" carriage bolt (F) through the height adjustment handle, the star washer and the height adjustment strap. Assemble a 5/16" flat washer (K) and the plastic knob (X) onto the end of the bolt.

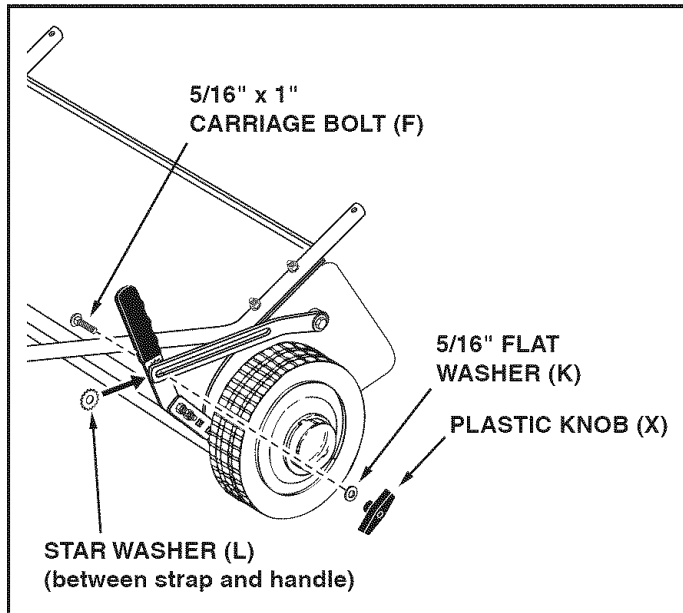

FIGURE 11

ASSEMBLY OF HOPPER BAG

STEP 11: (SEE FIGURE 12 AND 13)

- Turn a rear hopper tube so that the brace holes in the middle of the tube **face down**. Slide the tube through the two loops sewn to the top rear seam inside the hopper bag.

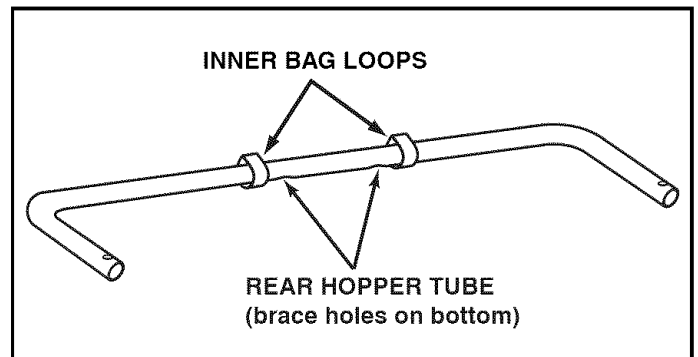

FIGURE 12

- Insert the two upper hopper side tubes through the stitched flaps on each side of the hopper bag.
- Assemble the ends of the rear hopper tube onto the ends of the upper hopper side tubes. Fasten together using plastic plugs (Z).

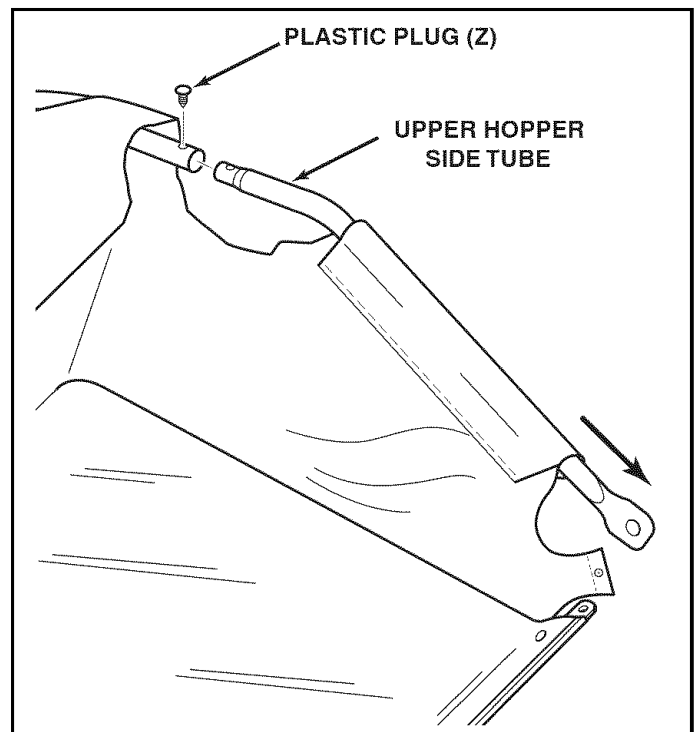

FIGURE 13

STEP 12: (SEE FIGURE 14 AND 15)

- Turn the second rear hopper tube so that the brace holes in the middle of the tube **face up**. Assemble the ends of the rear hopper tube onto the ends of the lower hopper side tubes. Fasten together using plastic plugs (Z).

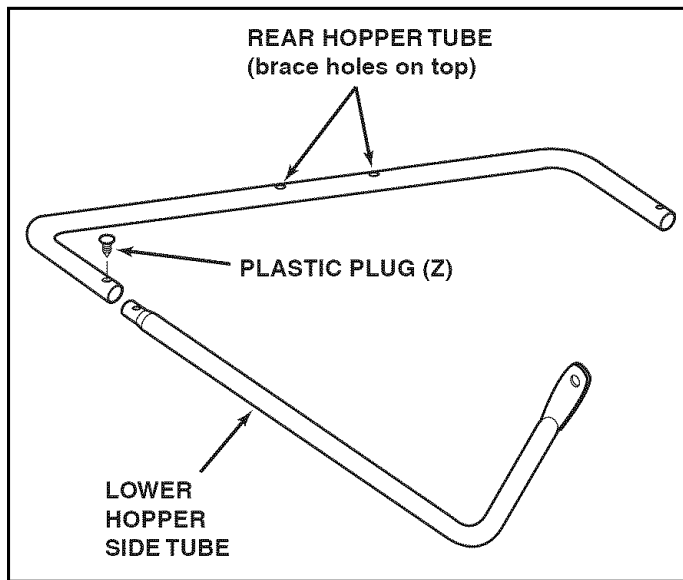

FIGURE 14

- Place the assembled lower hopper tubes into the bottom of the hopper bag
- Attach the ends of the lower hopper side tubes to the **inside** of the upper hopper side tubes using two 3/8" x 1/2" clevis pins (O) inserted from the inside, and two 3/32" hair cotter pins (N).

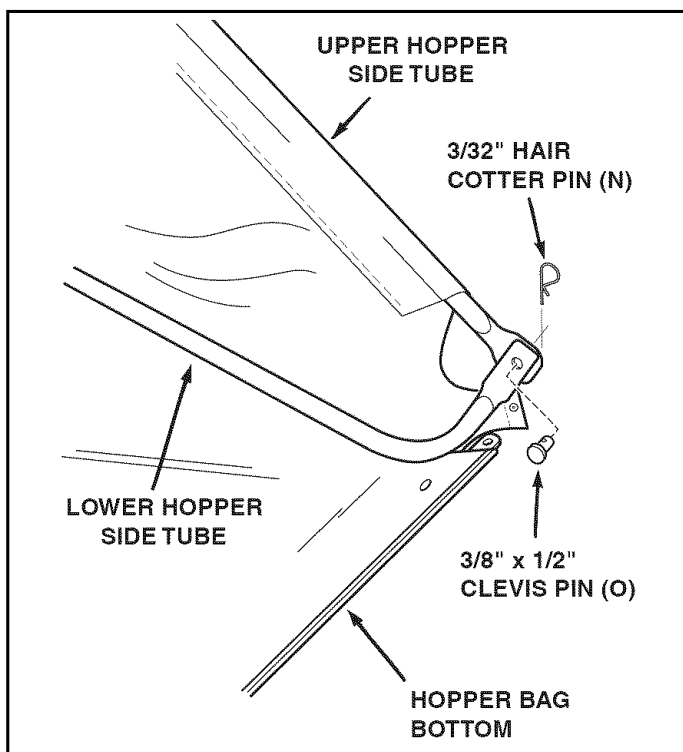

FIGURE 15

STEP 13: (SEE FIGURE 16 AND 17)

- Insert the bag frame strap into the stitched sleeve along the front edge of the bag bottom.
- Assemble the bag frame strap to the lower hopper side tubes using two 1/4" x 1-1/8" clevis pins (P) and 3/32" hair cotter pins (N).

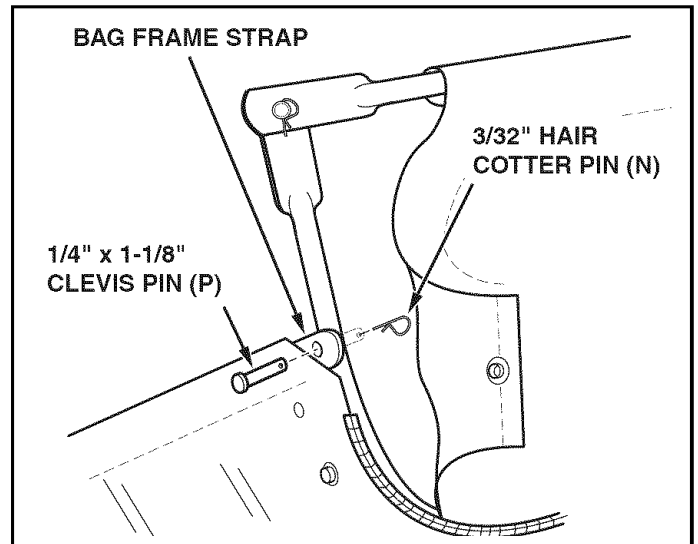

FIGURE 16

- Secure the bag corners around the lower hopper side tubes by snapping the bag flaps to the bag bottom on both sides.

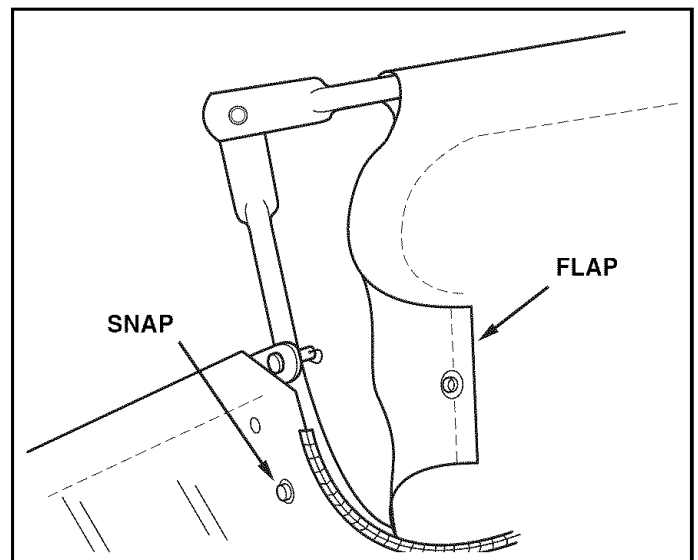

FIGURE 17

STEP 14: (FIGURE 18)

IMPORTANT: Do not over bend the support rods during the following step. Over bending will cause the steel rods to loose supporting tension.

- Tip the hopper onto it's back to assemble the two hopper support rods. Place the ends of each rod into the upper and lower rear hopper tubes, bending the rod just enough to fit into the holes in the tubes.

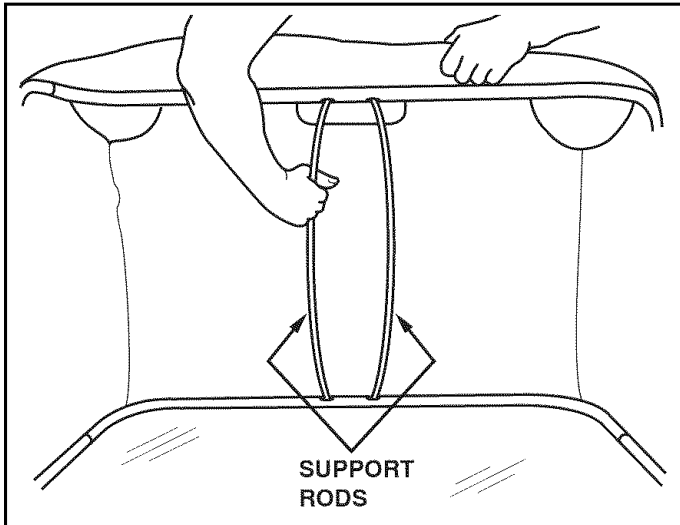

FIGURE 18

STEP 15: (FIGURE 19)

- Insert a 3/8" x 3" clevis pin (R) through the lower hole in each upper hopper side tube. Next assemble a bag arm tube onto each clevis pin and secure it with a 3/32" hair cotter pin (N).
- Assemble a vinyl cap (V) onto the end of each bag arm tube.

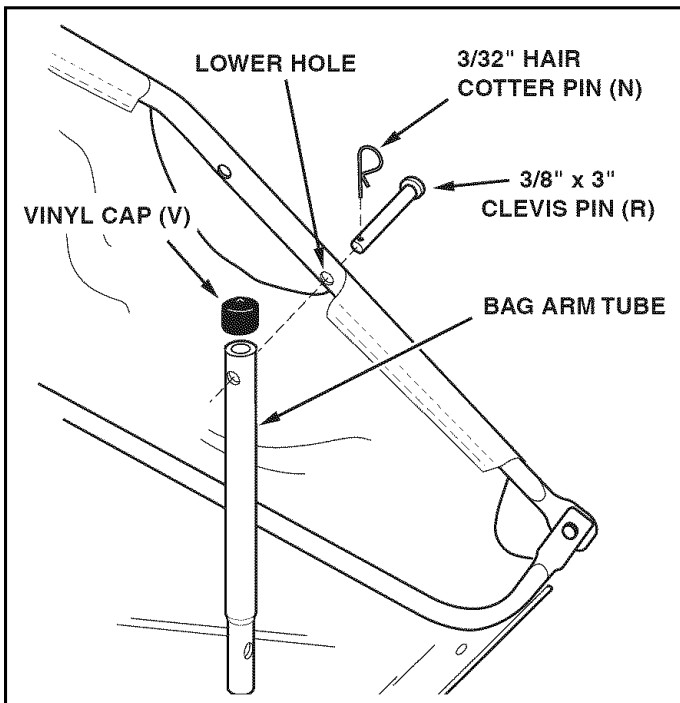

FIGURE 19

STEP 16: (SEE FIGURE 20 AND 21)

- Secure the rope to the top center of the hopper bag frame.

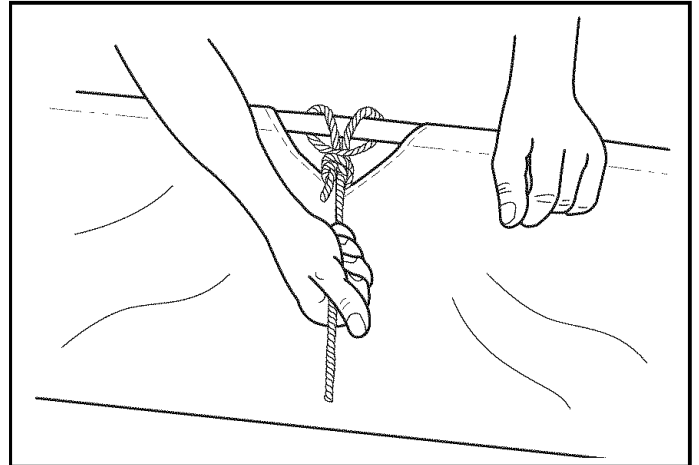

FIGURE 20

- To assemble the hopper bag to the sweeper, slide the ends of the bag arm tubes into the ends of the sweeper's hitch tubes and secure with two 1/4" x 1-3/4" clevis pins (Q) and 3/32" hair cotter pins (N).

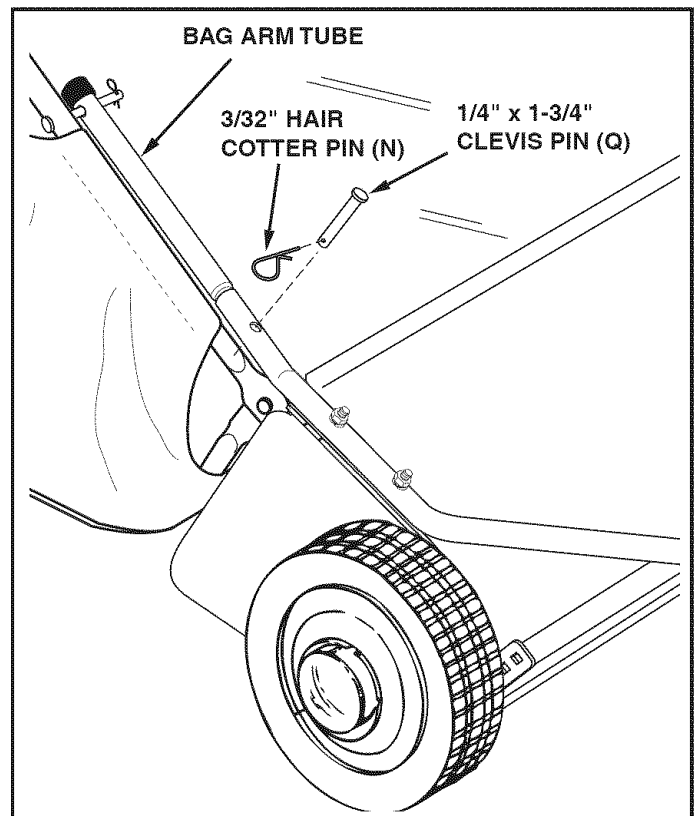

FIGURE 21

STEP 16: (SEE FIGURE 22, 23 AND 24)

- Place the tractor and sweeper on a flat level surface.
- Set the sweeper height adjustment handle to about the middle of its adjustment range.
- Attach the sweeper hitch brackets to the tractor hitch, arranging the 3/4" spacers so that the bottom of the sweeper bag is approximately level and 5" to 7" above the ground. See figure 23 for tractor hitches that are 10" to 13" above the ground. See figure 24 for tractor hitches that are 8" to 10" above the ground.

IMPORTANT: For best performance, the bottom of the sweeper bag should be approximately level and 5" to 7" off the ground as shown in figure 22.

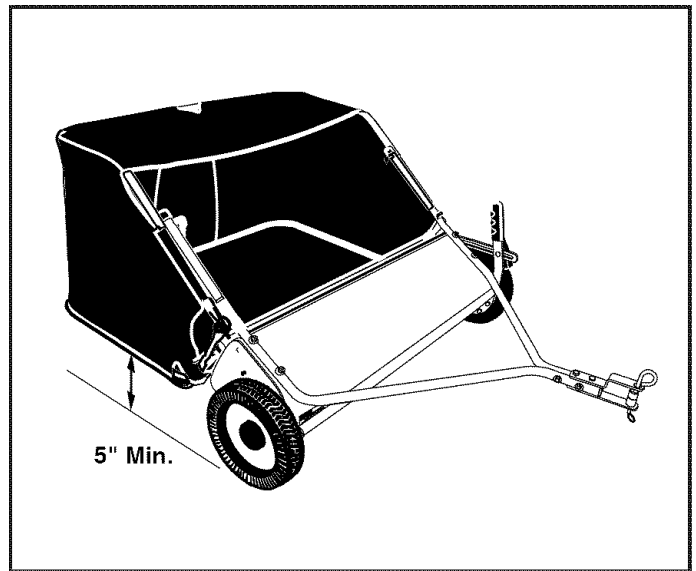

FIGURE 22

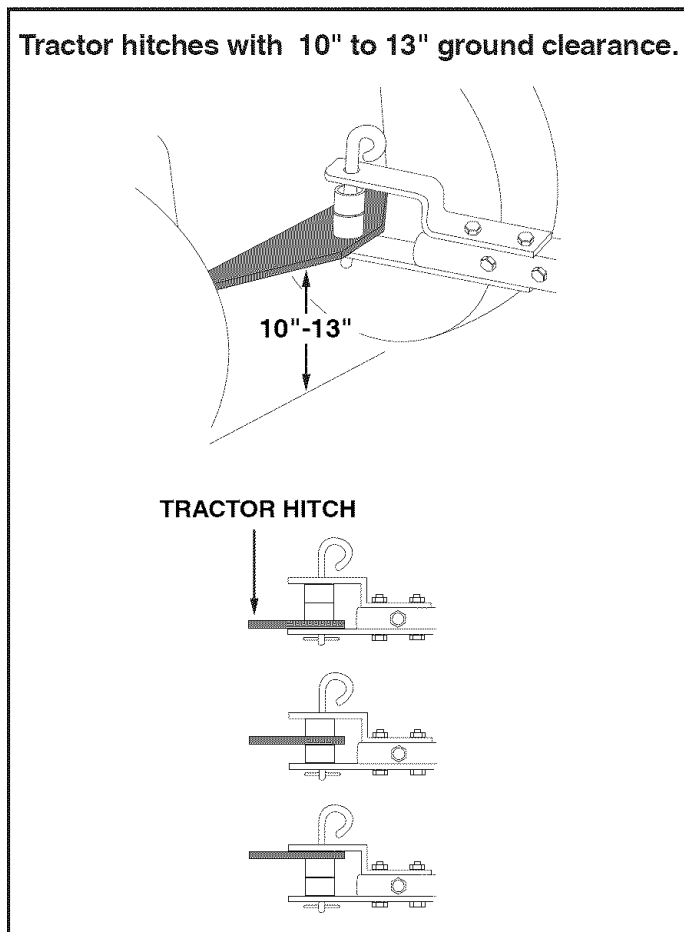

FIGURE 23

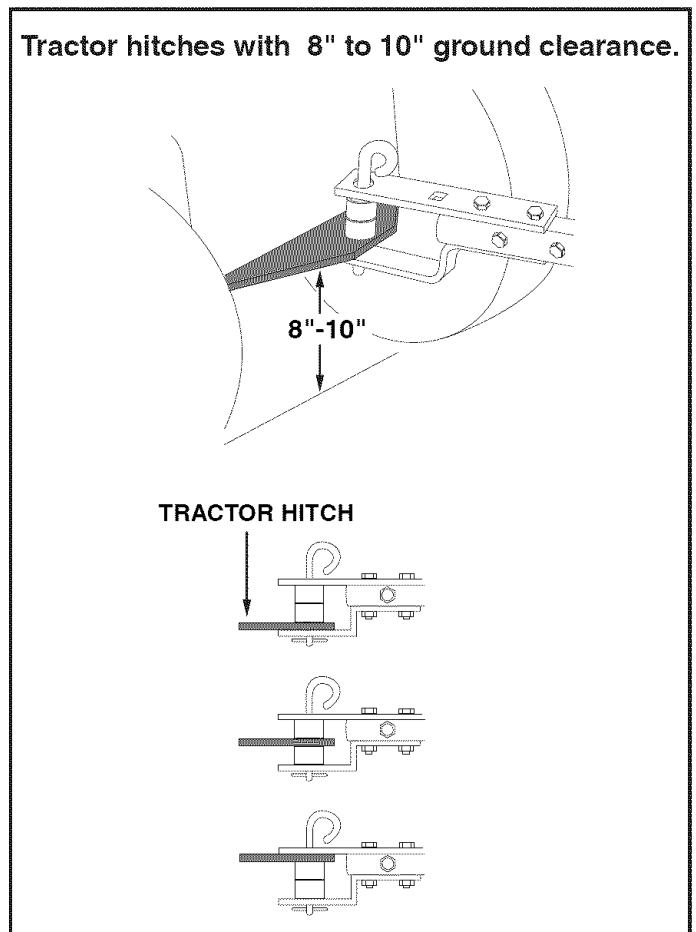
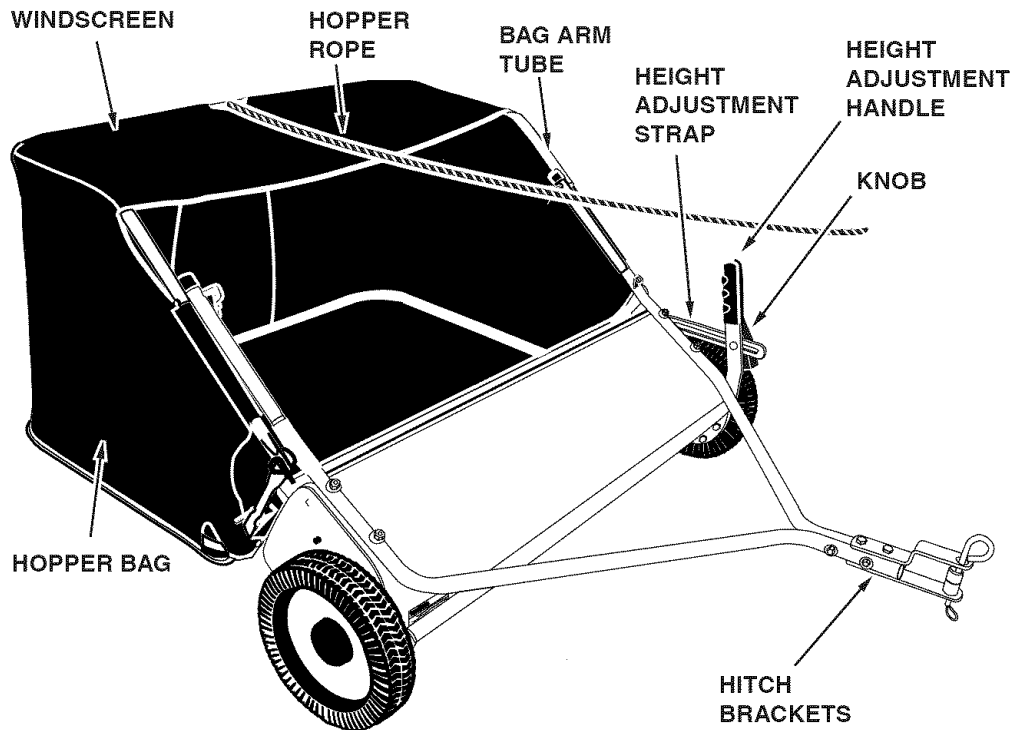

FIGURE 24

OPERATION

KNOW YOUR SWEEPER



| | |
|--------------------------|---|
| Hopper Bag | Collects grass clippings, leaves and debris. |
| Hopper Rope | Permits dumping of hopper bag from driver's seat. |
| Windscreen | Helps prevent collected material from being blown out of hopper bag. |
| Bag Arm Tubes | Connects the hopper bag to the sweeper housing. |
| Height Adjustment Handle | Adjusts the operating height of the sweeper. |
| Height Adjustment Strap | Holds the height adjustment handle in position when locked. |
| Knob | Locks the height adjustment handle to the height adjustment strap. |
| Hitch Bracket | Connects the sweeper to the towing vehicle. Adjusts for various height tractor hitches. |

HOW TO USE YOUR SWEEPER

BRUSH HEIGHT ADJUSTMENT

- To adjust your sweeper brushes to the best operating height, loosen the adjustment knob and push down on the height adjustment lever to raise the brush, or push up on the lever to lower the brush. See figure 22. Best adjustment is when the brush setting is 1/2" down into the grass. Always mow the grass to an even height before sweeping.

SWEEPING SPEED

- Try a starting speed of approximately 3 m.p.h. (third gear on most tractors). Depending on the conditions, it may be necessary to adjust the sweeping speed in order to achieve best results.

DUMPING OF SWEEPER

- Your sweeper can be dumped easily without getting off of the rider or tractor. Simply pull the rope forward to dump the hopper. Always empty hopper after each use.



CAUTION: Never attach the hopper rope to any part of your body or clothing! Never hold onto the rope while towing the sweeper! Attach the rope to the towing vehicle to keep it away from wheels and rotating parts.



CAUTION: Keep sweeper away from fire. Excessive heat can damage the brushes and hopper bag and could cause the bag and its contents to burn.

MAINTENANCE

CUSTOMER RESPONSIBILITIES

- Read and follow the maintenance schedule and the procedures listed in the maintenance section.

| MAINTENANCE SCHEDULE Fill in dates as you complete regular service. | Service Dates | | | | | |
|--|-----------------|----------------|--------------|--------------|----------------|-----------------|
| | Before each use | After each use | Twice a year | Every season | Before storage | Every two years |
| Check for loose fasteners | X | | | | | |
| Check for worn or damaged parts | X | | X | | | |
| Lubricate brush shaft bearings | | X | | | | |
| Lubricate wheel bearings | | | X | | | |
| Clean Sweeper | X | | | X | | |
| Clean/Lubricate chain and sprockets | | | | | X | |

SCHEDULED MAINTENANCE

- Clean the sweeper after each use.
- Inspect for worn or damaged parts, such as brushes and wheels.
- Lubricate the brush shaft bearing twice a year with a few drops of light weight oil. See figure 25.

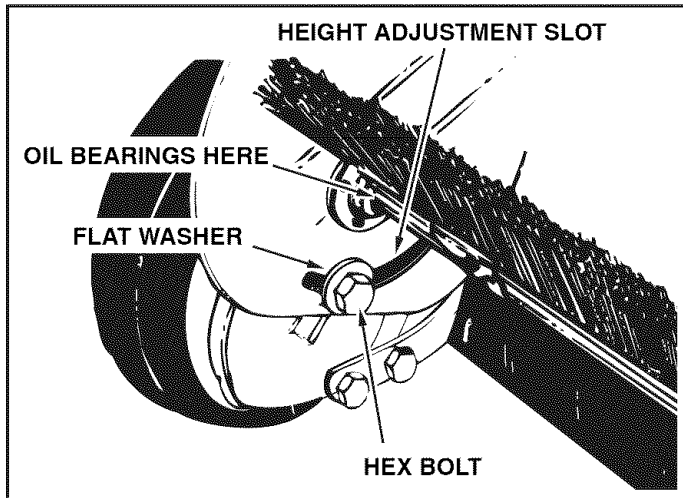

FIGURE 25

- Every two years, remove the wheels and clean the gears found inside the wheel housing. After cleaning, lubricate the gears with an even coat of light grease. To remove the wheel, pop off the hub cap and remove the lock nut and flat washer. See figure 26.

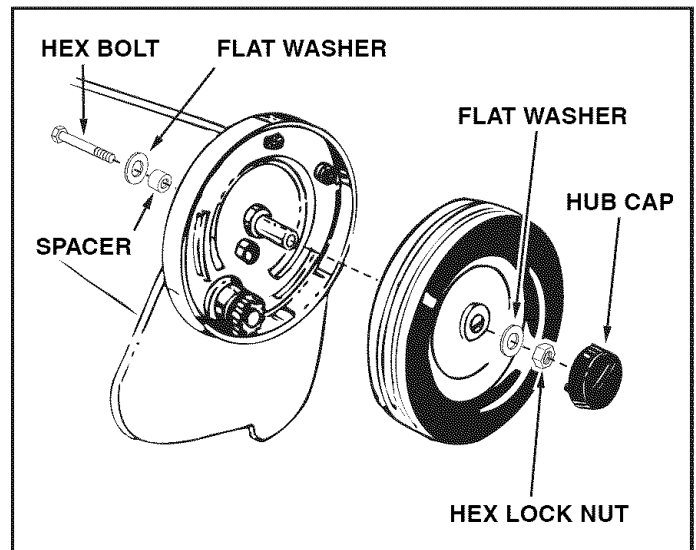

FIGURE 26

CLEANING

- Clean sweeper housing with a soft brush or cloth.
- Clean debris from hopper bag with a brush or broom.
- Remove any material which has wrapped around brushes or ends of brush shaft.

STORAGE



CAUTION: Before storing the sweeper, always empty the hopper bag to avoid spontaneous combustion.

- Clean the sweeper and hopper bag thoroughly to help prevent rust and mildew.
- To collapse the hopper bag for storage, remove the two hopper support rods from the rear of the hopper.
- Store in a dry area.

SERVICE AND ADJUSTMENTS

BRUSH REPLACEMENT

NOTE: Brush replacement should be done one brush at a time.

- Remove the hopper bag from the sweeper.
- Loosen the hex bolts and lock nuts on two single brush retainers which clamp one brush to the double brush retainers. **Do Not loosen** or remove the bolts which fasten the double brush retainers to the brush shaft. See figure 27.
- Slide the brush out of the retainers, noting on which side of the brush the bristles overlap. See figure 27.
- Install new brush, making sure the bristles overlap on the same side of the brush as before. See figure 27.

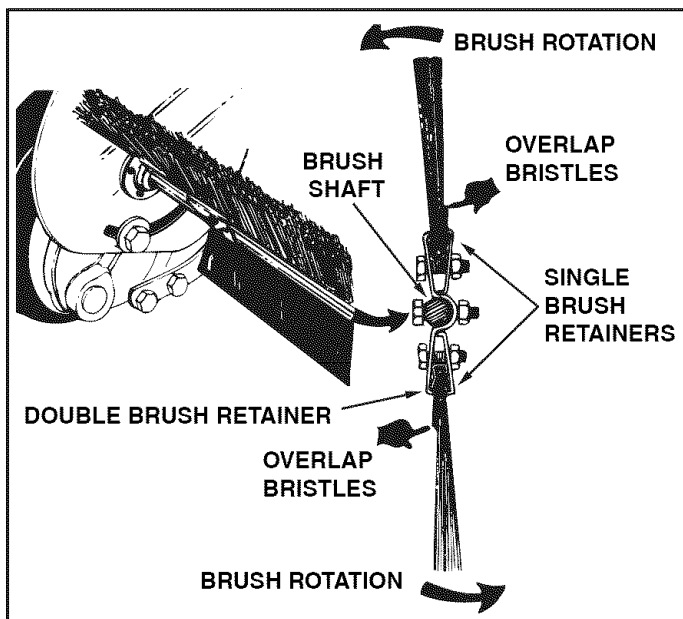

FIGURE 27

WHEEL GEAR AND PAWL SERVICE

IMPORTANT: Do not remove both wheels at the same time to avoid mixing of parts. (The R.H. and L.H. ratchet sprockets are not interchangeable.) **Make notes** on the position of washers and snap rings during disassembly.

- Remove **only one** wheel from the sweeper.
- Remove the retaining rings and washers which hold the ratchet gear on the brush shaft.
- Slide the gear off of the brush shaft. (Look for the drive pin, which may fall out of the brush shaft when the ratchet gear is removed.) See figure 28.
- To reassemble, insert the drive pin through the hole near the end of the brush shaft. Make sure the pin slides back and forth easily in the shaft.
- Lightly grease the shaft and fill the ratchet gear with grease. Assemble the ratchet gear back onto the shaft.
- Lightly grease the axle and the gear teeth on the wheel, and then reassemble the wheel. The brushes should rotate **only** during forward rotation of the wheel. If the brushes are driven (rotated) by both forward and reverse rotation of the wheel, the drive pin is jamming in the ratchet gear. Disassemble to clean and lubricate the drive pin and the ratchet gear.
- Remove the second wheel and repeat the procedure.

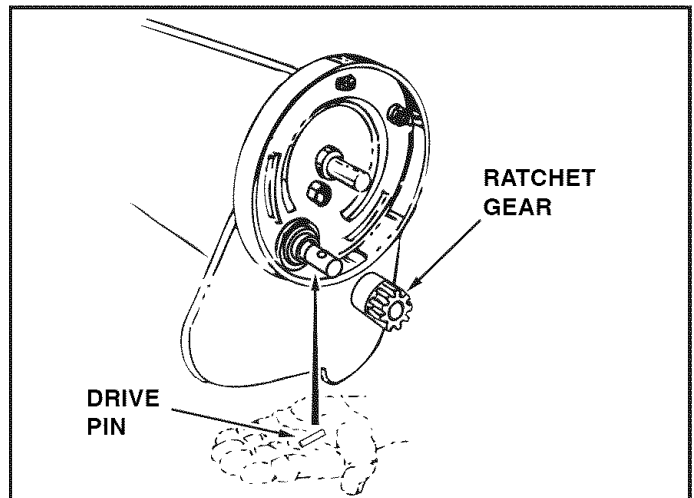

FIGURE 28

TROUBLESHOOTING

| | | |
|-----------------------------------|--|---|
| <p>Wheels skid when sweeping.</p> | <ul style="list-style-type: none"> • Brushes set too low. • Brushes are jammed • Wheels are jammed. | <ul style="list-style-type: none"> • Adjust height till brushes are 1/2" down into grass. • Stop sweeper. Remove obstruction. • Remove one wheel at a time to check for obstruction or damage. Refer to Service and Adjustments section. |
|-----------------------------------|--|---|

NOTES

PARTS

REPAIR PARTS FOR MODEL 486.242211 - 42" LAWSWEEPER

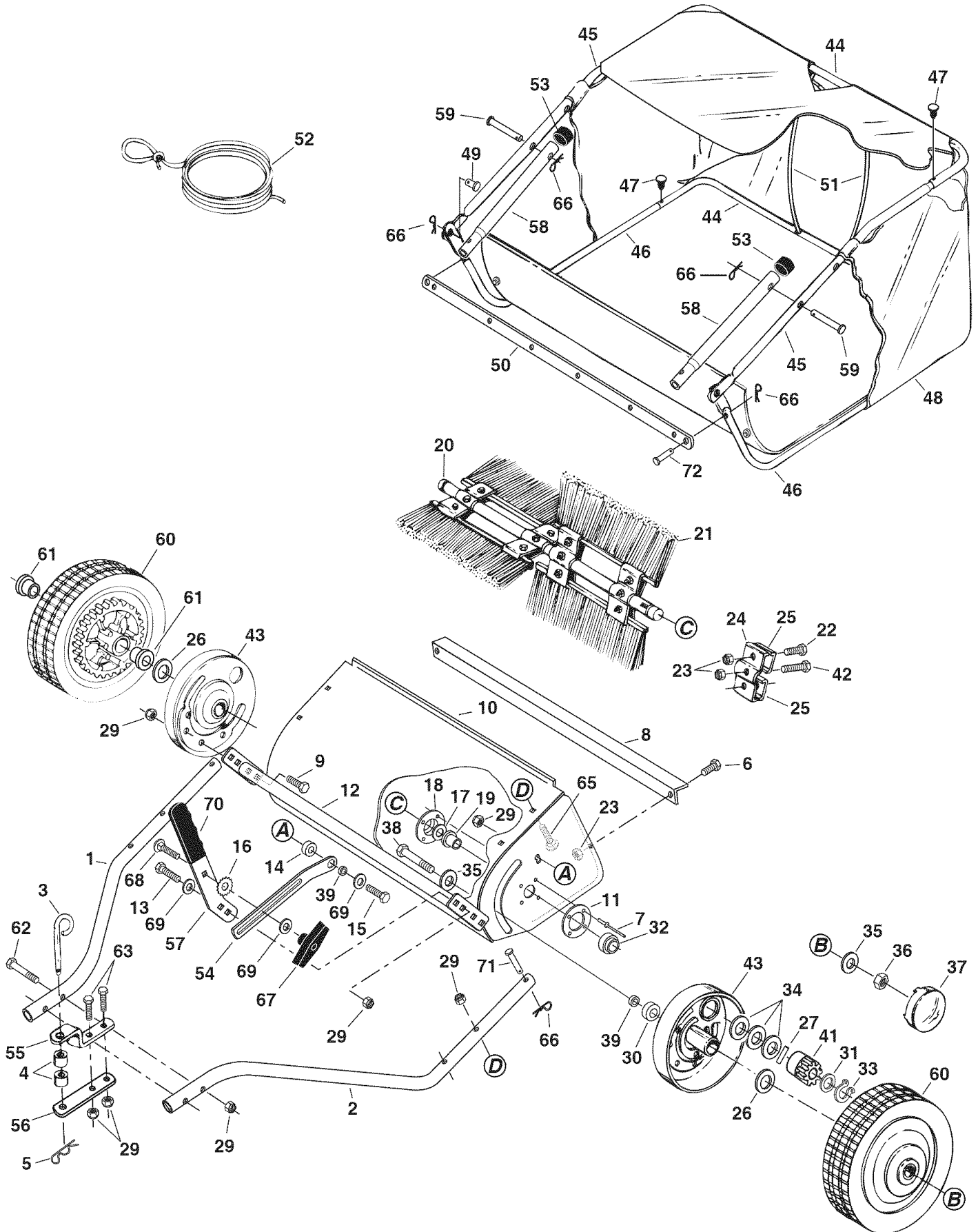

REPAIR PARTS FOR MODEL 486.242211, 42" LAWN SWEEPER

| REF | PART NO. | QTY | DESCRIPTION | REF | PART NO. | QTY | DESCRIPTION |
|-----|-----------|-----|---------------------------------------|-----|----------|-----|-------------------------------------|
| 1 | 40614 | 1 | Hitch Tube, R.H. | 38 | 44961 | 2 | Bolt, Hex 3/8-24 x 3-1/4" Lg. |
| 2 | 40615 | 1 | Hitch Tube, L.H. | 39 | 23400 | 3 | Bushing, Pivot |
| 3 | 23353 | 1 | Pin, Hitch | 40 | 48652 | 1 | Gear, Pinion R.H. (not shown) |
| 4 | 23368 | 2 | Tube, Hitch Spacer | 41 | 48651 | 1 | Gear, Pinion L.H. |
| 5 | 43343 | 1 | Hairpin Cotter, 1/8" #4 | 42 | 43661 | 4 | Bolt, Hex 1/4-20 x 1" Lg. |
| 6 | 43175 | 2 | Bolt, Hex 1/4-20 x 1/2" Lg. | 43 | 64559 | 2 | Ass'y, Dust Cover |
| 7 | C-9M5732 | 8 | Rivet, Pop | 44 | 48587 | 2 | Tube, Hopper Frame (Rear) |
| 8 | 24185 | 1 | Brace, Rear Support | 45 | 48466 | 2 | Tube, Upper Hopper Frame (Front) |
| 9 | 43182 | 4 | Bolt, Hex 5/16-18 x 3/4" | 46 | 48726 | 2 | Tube, Lower Hopper Frame (Front) |
| 10 | 66137 | 1 | Sweeper Housing Assembly | 47 | 48402 | 4 | Plastic Plug |
| 11 | 23336 | 2 | Washer, Special | 48 | 48388 | 1 | Hopper Bag |
| 12 | 66070 | 1 | Height Adjustment Tube Assembly | 49 | 48366 | 2 | Clevis Pin, 3/8" x 1/2" |
| 13 | 43063 | 2 | Bolt, Hex 5/16-18 x 1" | 50 | 24949 | 1 | Strap, Bag Frame |
| 14 | 25408 | 1 | Bushing, Spacer | 51 | 43926 | 2 | Rod, Hopper Support |
| 15 | 43840 | 1 | Bolt, Hex 5/16-18 x 1-1/4" | 52 | 43737 | 1 | Hopper Rope |
| 16 | 44732 | 1 | Washer, Star | 53 | 44481 | 2 | Cap, Vinyl |
| 17 | R19212113 | 2 | Washer, 5/8" SAE | 54 | 24979 | 1 | Strap, Height Adjustment |
| 18 | 1629-56 | 2 | Retainer, Dust Cover | 55 | 23687 | 1 | Bracket, Hitch |
| 19 | 44910 | 2 | Bushing, Brush Shaft | 56 | 24192 | 1 | Bracket, Hitch (Straight) |
| 20 | 25850 | 1 | Brush Shaft | 57 | 26243 | 1 | Handle, Height Adjustment |
| 21 | 48557 | 4 | Brush | 58 | 40621 | 2 | Tube, Bag Arm |
| 22 | 43012 | 8 | Bolt, Hex 1/4-20 x 3/4" Lg. | 59 | 43513 | 2 | Pin, Clevis 3/8" x 3" |
| 23 | 47189 | 14 | Nut, Nylock 1/4-20 | 60 | 44985 | 2 | Wheel & Tire Ass'y. (with bearings) |
| 24 | 23580 | 4 | Retainer, Brush (Double) | 61 | 45088 | 4 | Wheel Bearing |
| 25 | 23581 | 8 | Retainer, Brush (Single) | 62 | 44292 | 2 | Bolt, Hex 5/16-18 x 2-1/2" Lg. |
| 26 | 44008 | 2 | Washer, Flat 1-1/8" x .78" x .025" | 63 | 44180 | 2 | Bolt, Hex 5/16-18 x 2" Lg. |
| 27 | 47046 | 2 | Dowel Pin (Drive) | 65 | 43681 | 4 | Bolt, Carriage 5/16-18 x 1-1/2" |
| 29 | 47810 | 15 | Nut, Nylock 5/16-18 | 66 | 43055 | 8 | Hairpin Cotter, 3/32" #3 |
| 30 | 44911 | 2 | Spacer, .39 I.D". x 1-1/4" O.D. x .5" | 67 | 43720 | 1 | Knob, Wing 5/16-18 Thread |
| 31 | 44006 | 2 | Washer, Flat .849" x .598" x .025" | 68 | 44326 | 1 | Bolt, Carriage 5/16-18 x 1" |
| 32 | 46219 | 2 | Spacer, .78 I.D". x 1-1/4" O.D. x .5" | 69 | 43081 | 4 | Washer, Flat 5/16" Std. Wrt. |
| 33 | 1650-21 | 2 | Ring, Retaining .594" | 70 | 43943 | 1 | Grip, Height Adjust |
| 34 | 40001 | 6 | Washer, Shim 1-1/8" x .594" x .025" | 71 | 46867 | 2 | Clevis Pin, 1/4" x 1-3/4" Lg. |
| 35 | 141 | 4 | Washer, Flat 1-1/2" x .375" x .062" | 72 | 48365 | 2 | Clevis Pin, 1/4" x 1-1/8" |
| 36 | 1038 | 2 | Nut, Nylock Jam 3/8-24 Thread | | 40637 | 1 | Owners Manual |
| 37 | 2674-32 | 2 | Hub Cap | | | | |

NOTES

NOTES

Get it fixed, at your home or ours!

Your Home

For repair – **in your home** – of all major brand appliances, lawn and garden equipment, or heating and cooling systems, **no matter who made it, no matter who sold it!**

For the replacement parts, accessories and owner's manuals that you need to do-it-yourself.

For Sears professional installation of home appliances and items like garage door openers and water heaters.

1-800-4-MY-HOME® (1-800-469-4663)

Call anytime, day or night (U.S.A. and Canada)

www.sears.com www.sears.ca

For expert home solutions advice: www.managemyhome.com

Our Home

For repair of carry-in items like vacuums, lawn equipment, and electronics, call or go on-line for the location of your nearest

Sears Parts & Repair Service Center

1-800-488-1222 (U.S.A.) 1-800-469-4663 (Canada)

Call anytime, day or night

www.sears.com www.sears.ca

To purchase a protection agreement on a product serviced by Sears:

1-800-827-6655 (U.S.A.)

1-800-361-6665 (Canada)

Para pedir servicio de reparación a domicilio, y para ordenar piezas:

1-888-SU-HOGAR®

(1-888-784-6427)

Au Canada pour service en français:

1-800-LE-FOYER^{MC}

(1-800-533-6937)

www.sears.ca

